

# **Master`s degree thesis**

**IP502009 MSC thesis, Professional master**

**Ship response and manoeuvrability -  
Main machinery characteristics, configuration modes,  
and its resulting effect on thrust response.**

**Proposed dynamic ship merit factor/index.**

**Arne Solevåg**  
Candidate nr.: 10002

## **Master of Science in Ship Design**

Submission date: Aalesund, December 2016  
Supervisor: Karl Henning Halse  
Co-supervisor: Vilmar Æsøy

Number of pages including this page: 104  
(Only Appendix D included in electronic document, Appendix A-D handed over to supervisor)



## Mandatory statement

Each student is responsible for complying with rules and regulations that relate to examinations and to academic work in general. The purpose of the mandatory statement is to make students aware of their responsibility and the consequences of cheating. **Failure to complete the statement does not excuse students from their responsibility.**

<i>Please complete the mandatory statement by placing a mark <u>in each box</u> for statements 1-6 below.</i>		
1.	<b>I/we hereby declare that my/our paper/assignment is my/our own work, and that I/we have not used other sources or received other help than is mentioned in the paper/assignment.</b>	<input checked="" type="checkbox"/>
2.	<b>I/we hereby declare that this paper</b> 1. Has not been used in any other exam at another department/university/university college 2. Is not referring to the work of others without acknowledgement 3. Is not referring to my/our previous work without acknowledgement 4. Has acknowledged all sources of literature in the text and in the list of references 5. Is not a copy, duplicate or transcript of other work	Mark each box: 1. <input checked="" type="checkbox"/> 2. <input checked="" type="checkbox"/> 3. <input checked="" type="checkbox"/> 4. <input checked="" type="checkbox"/> 5. <input checked="" type="checkbox"/>
3.	<b>I am/we are aware that any breach of the above will be considered as cheating, and may result in annulment of the examination and exclusion from all universities and university colleges in Norway for up to one year, according to the <a href="#">Act relating to Norwegian Universities and University Colleges, section 4-7 and 4-8</a> and Examination regulations .</b>	<input checked="" type="checkbox"/>
4.	<b>I am/we are aware that all papers/assignments may be checked for plagiarism by a software assisted plagiarism check</b>	<input checked="" type="checkbox"/>
5.	<b>I am/we are aware that NTNU will handle all cases of suspected cheating according to prevailing guidelines.</b>	<input checked="" type="checkbox"/>
6.	<b>I/we are aware of the NTNU's rules and regulation for using sources.</b>	<input checked="" type="checkbox"/>

## Publication agreement

ECTS credits: 90

Supervisor: Karl Henning Halse and Wilmar Æsøy

### Agreement on electronic publication of master thesis

Author(s) have copyright to the thesis, including the exclusive right to publish the document (The Copyright Act §2).

All theses fulfilling the requirements will be registered and published in Brage, with the approval of the author(s).

Theses with a confidentiality agreement will not be published.

I/we hereby give NTNU the right to, free of charge, make the thesis available for electronic publication:  yes  no

Is there an **agreement of confidentiality**?  yes  no

(A supplementary confidentiality agreement must be filled in and included in this document)

- If yes: **Can the thesis be online published when the period of confidentiality is expired?**  yes  no

This master's thesis has been completed and approved as part of a master's degree programme at NTNU Ålesund. The thesis is the student's own independent work according to section 6 of Regulations concerning requirements for master's degrees of December 1st, 2005.

Date: 2016-12-16

TITLE:

## Master Thesis:

# Ship response and manoeuvrability - Main machinery characteristic, configuration modes, and its resulting effect on thrust response.

## Proposed dynamic ship merit factor/index.

CANDIDATE NO.: **10002**

DATE: 16.12.2016	COURSE CODE: IP502009	COURSE TITLE: Msc thesis, professional master 90 ECTS	RESTRICTION:
STUDY PROGRAM: Msc, Ship Design		PAGES/APPENDIX: xx/-	LIBRARY NO.:

SUPERVISOR(S): KARL HENNING HALSE, VILMAR ÆSØY

### ABSTRACT:

This thesis have in general been divided into three parts: Discussion about the traditional approach for station keeping and manoeuvring capability (static approach with dynamic factor), use of more modern tools analysing dynamic capabilities of the vessels (DynCap, and DNVGL DP Level3); Detail study of the main machinery systems as generators and thrusters with their control system to establish and understand the theory and relation between them; Development of a design configuration systematics enabling us to have parameters to perform early stage dynamic calculation analysis and establish dynamic equipment and ship merit factor.

There are already today several providers of dynamic simulation tools where you could build virtual models of your vessel and perform analysis at early design. As far as I have found there is no standard way of building the various parts of the models, and these models includes simplifications and assumptions. If we don't properly understand the relations we could end up thrusting the early stage dynamic models and the resulting vessel behaviour too much.

This thesis propose two levels of early design approach to ensure that the designer have understanding of applicable load combinations and dynamic relation of combination of main propulsion machinery configurations. The equipment category and dynamic merit factors proposed in Part 2, could form a basis for a future dynamic categorization system that will enable us to make better use of 3<sup>rd</sup> party dynamic analysing tools at an early design phase ("correct" input). Or at least evaluate their results.

I have not found other work that tries to link, generalize and simplify the dynamic relations between main machinery and their control systems at an overall level with the intention to make a simple design tool for selecting equipment based on their dynamic behaviour and dependencies.

The future for vessels with dynamic position/manoeuvring systems on board I believe will be to have full scale vessel specific dynamic calculating model incorporated in their control systems, calculating probable resulting deviating positions in event of failures or changed weather.

But I still believe that the industry needs an early stage simple design tool or approach to understand and ensure that the dynamic behaviour is understood and controlled.



# ***MSC Thesis Description Sheet***

## **Plan for Thesis Assignment**

**MASTER THESIS 2016  
FOR  
ARNE SOLEVÅG**

### **Ship response and manoeuvrability due to Dynamic loads and thrust response. Reasoning and effect related to time variable loads Proposed simplified method to establish Dynamic Ship Merit Factor**

One of the challenges in ship design is to make sure that a vessel is able to perform its tasks in a safe and efficient manner by defining optimal vessel design with respect to hull, propulsion, thruster and main power configurations.

It is therefore essential to determine the weather operational window where the vessel can maintain its speed, heading and position within some limits.

To establish a weather window, a static analysis is normally performed by balancing the maximum obtainable thruster force against a resultant mean environmental force due to wind, wave drift, current, and possible other loads.

Important assumptions and simplifications must be done to facilitate the analysis and the dynamic behaviour of the vessel and propulsion system is not considered, but allowed for by having a “margin”.

No criteria for thruster-response requirements are to my knowledge agreed upon in building specifications nor building contracts. Equipment manufacturers would possibly tend to like slow response and gradually build-up of thrust, due to maintenance and stability requirements etc. but are to my understanding not clearly stating their preference/limits, while the owner in many cases would like to have faster response.

When vessels like car ferries with marginal main machinery, propulsion and thrust arrangements are tested at trials, and possibly found with slow vessel response one of the few parameters that could be adjusted is the thrust response time/curve.

To adjust this could have implications for both the equipment, the vessels machinery, power management system and built in blackout prevention systems etc.

The thesis will be divided in two parts:

**Part 1** will investigate how this is handled today. Investigate relevant propulsion, main machinery and control theory. This part will also try to establish normal dynamic power/thrust times by interviewing and actual measurements on-board actual vessels. Establish “normal” Power/Time graphs from “signal” to actual thrust and investigate how this effect the thruster and the relation to the main machinery system.

**Part 2** will use the main propulsion machinery and thrust response relations found in Part 1 to evaluate the vessels dynamic capabilities and to develop a simplified methodology for selecting a normal range of Thrust Response Times linked to the Main Machinery and modes (generators online). And propose a system enabling us to make a dynamic merit factor for a vessel

Pre-study:

- Study typical propulsion and main machinery configurations
- Investigate earlier work related to the topic, and propose a literature study
- Identify relevant theory related to propeller and thruster characteristics
- Identify and understand the reasoning for dynamic effect from a thruster, main machinery and control system perspective.
- Investigate earlier work related to modelling of dynamic stability of vessels
- Find partners, enabling me to establish data

Thesis and model development:

Part 1:

- Establish actual thrust power / time curves for various vessel
- Use theory to explain/evaluate the measurements
- Perform simulations on selected cases

Part 2:

- Investigate modelling related to dynamic stability of ships
- Use result from Part 1 together with dynamic modelling theory to propose simplified dynamic merit factor for vessels
- Compare data and method to real systems and models

The work scope may prove to be larger than initially anticipated. Subject to approval from the supervisor, topics may be deleted from the list above or reduce in extent.

The thesis should be written as a research report with summary, conclusion, literature references, table of contents, etc. During preparation of the text, the candidate should make efforts to create a well arranged and well written report. To ease the evaluation of the thesis, it is important to cross-reference text, tables and figures. For evaluation of the work a thorough discussion of results is needed. Discussion of research method, validation and generalization of results is also appreciated. Further references to thesis requirements are found in the course description <http://www.hials.no/eng/content/view/full/66020/language/eng-GB> with special attention to the section "evaluation".

In addition to the thesis, a research paper for publication shall be prepared.

Three weeks after start of the thesis work, a pre-study have to be delivered. The pre-study have to include:

- Research method to be used
- Literature and sources to be studied
- A list of work tasks to be performed

A templates and instructions for thesis documents and A3-poster are available on the Fronter website under MSc-thesis. Please follow the instructions closely, and ask your supervisor or program coordinator if needed.

The thesis shall be submitted in electronic version according to new procedures from 2014. Instructions are found on the college web site. In addition one paper copy of the full thesis with a CD including all relevant documents and files shall be submitted to your supervisor.

The thesis shall be submitted as two paper versions. One electronic version is also requested on a CD or a DVD, preferably as a pdf-file.

Supervision at Aalesund UC.: Karl Henning Halse and Vilmar Æsøy

Karl Henning Halse  
Supervisor

Finish: \_\_\_\_\_ Signature

candidate: \_\_\_\_\_



## **PREFACE**

One of the main challenges in ship design is to make sure that a vessel is able to perform its tasks in a safe and efficient manner. The industry has therefore created vessels and systems with high degree of integration between various systems and their control systems.

The result is flexible, cost effective and more environmental friendly vessels, but it have also its challenges related to higher degree of complexity and need for operational awareness and understanding.

It is therefore essential that the designer understand the interactions between the vessels different system, to be able to determine the weather operational window where the vessel can maintain its speed, heading and position within some limits.

To establish a weather window, a static analysis is normally performed by balancing the maximum obtainable thruster force against a resultant mean environmental force due to wind, wave drift, current, and possible other loads.

Important assumptions and simplifications must be done to facilitate the analysis and the dynamic behaviour of the vessel and propulsion system is normally not considered, but allowed for by having a “margin” or dynamic factor.

No criteria for thruster response requirements, are to my knowledge agreed upon in building specifications, nor building contracts, and not always either given in specifications from equipment manufacturer. The manufacturers of the various equipment would possible tend to like slow response, gradually build-up of thrust, this due to maintenance and stability requirements etc. But they are not clearly stating their preference/limits. While the owner from a manoeuvring point of view in many cases would like to have faster response.

When vessels like car ferries with marginal main machinery installations, (and for vessels that intend to operate with only a limited number of diesel electric engine connected at the same time) have their propulsion and thrust arrangements tested at trails, the result might be that you need to tune down the response rate for various equipment to meet the main machinery’s limitation. This might result in slow vessel response as one of the few parameters that could be adjusted, at this late stage is the thrust response time/curve.

These adjustments have implications for the equipment, the vessels main power generating machinery, power management system, black out prevention and DP/manoeuvring tuning as well as crash stop distance etc. for the vessel.

This study will try to investigate the interaction between main machinery, to better understand the reasoning, - and effect of these interactions. It will be at an overall level studying the consumers and the producers, and will establish some guidance related to dynamic merits for main propulsion system and the vessel as such.

A literature study of relevant papers, articles and books is conducted to better understand the theory and background around the topic. This to understand what research has already been conducted linked to my topic, and to be able to focus my study and base the foundation on others work and insight.

The study also include contact with industry partners enabling me to get actual data related to time-varying thrust response for different types of main propulsion systems and side thrust system as well as azimuth propulsion systems.

The theses will in part 2 propose a design method, or procedure to take into consideration the dynamic behaviour of main equipment, and the vessel as such, at an early design stage.

This procedure propose a simple systematic for selecting a set of parameters for various equipment enabling us to perform a dynamic simulations at a design phase, without knowing how the vessel ended up finally tuned. The vessel will then have a set of limits it will have to fulfil during tuning and these settings should be possible for the ship owner to order their vessels according to.

Hopefully such a standard categorisation for various equipment could result in a design system to simple establishing some kind of dynamic environmental regularity numbers, similar to the static ERN calculations and merits we know from DP vessels today.

This could be a system with various fault scenarios, or change in environmental conditions, simulation by time-domain tools and resulting dynamic operation window. Possible a dynamic ship merit number something like  $D_{(5m/5deg,10m/10deg,15m/15deg,20m/20deg)}$  ERN.

## **ABSTRACT**

This thesis have in general been divided into three parts: Discussion about the traditional approach for station keeping and manoeuvring capability (static approach with dynamic factor), use of more modern tools analysing dynamic capabilities of the vessels (DynCap, and DNVGL DP Level3); Detail study of the main machinery systems as generators and thrusters with their control system to establish and understand the theory and relation between them; Development of a design configuration systematics enabling us to have parameters to do early stage dynamic calculation analysis and establish dynamic equipment and ship merit factor.

There are already today several providers of dynamic simulation tools where you could build virtual models of your vessel and perform analysis at early design. As far as I have found there is no standard way of building the various parts of the models, and these models includes simplifications and assumptions. If we don't properly understand the dynamic relations, we could end up trusting the early stage dynamic models with the resulting vessel behaviour too much.

I have not found other work that tries to link, generalise and simplify the dynamic relations between main machinery and their control systems, at an overall level with the intention to make a simple design tool for selecting equipment based on their dynamic behaviour and dependencies.

The equipment category and dynamic merit factors proposed in part 2, could form a basis for a future dynamic categorization system, that will enable us to make better use of 3<sup>rd</sup> party dynamic analysing tools at an early design phase. Alternative to such open categorization and sharing of information of equipment capabilities, is to have fully integrated control and analyse systems for each design.

The future for vessels with dynamic position/manoeuvring systems on board, I believe will be to have full scale vessel specific dynamic calculating model incorporated in their control systems. These systems will calculate probable resulting deviating positions in event of failures or changed weather.

But in my view, we still need an early design tool, for us better to understand the dynamic relations and enable us to combine and utilize modern technologies and perform dynamic simulations with some assumptions before we select the final setup.

This thesis propose two levels for early design approach, to ensure that the designer have understanding of applicable load combinations and their dynamic relations, to main propulsion machinery configurations. The design philosophy and modes for operations should then be clearly stated, so that control systems etc. take this philosophy in to considerations.

I hope that this simple approach could result in more research and creation of refined tools, to better support decisions made early in the design process, enabling the industry to make better products and encounter less problems late in the building phase.

## **ACKNOWLEDGEMENTS**

I would like to thank my supervisors Karl Henning Halse and Vimar Æsøy for their support during my part time study, and for being my supervisors during this master thesis. I will also like to thank numerous colleagues and friends for being good discussion partners.

In addition, I will like to thank several persons and companies in the maritime industry that I have talked to, during my work with this thesis; they have provided me with valuable results and input. These partners have been anonymised not to reveal potential project specific results.

Finally I will like to thank my family, my wife Trine and our two children Nora and Markus for their understanding and support, you are the best! Not to forget my parents that have willingly helped out in several occasions driving Nora and Markus to various activities, helping them with their homework etc.

Arne Solevåg, December 2016

# TABLE OF CONTENTS

MSC THESIS DESCRIPTION SHEET .....	I
PREFACE .....	III
ABSTRACT .....	IV
ACKNOWLEDGEMENTS .....	V
<b>TABLE OF CONTENTS.....</b>	<b>VI</b>
TERMINOLOGY .....	IX
ABBREVIATIONS .....	IX
<b>1 INTRODUCTION.....</b>	<b>1</b>
1.1 PROJECT BACKGROUND .....	1
1.2 PREVIOUS WORK .....	7
1.3 PROBLEM FORMULATION .....	8
1.4 OBJECTIVES .....	9
<b>2 BACKGROUND AND THEORETICAL BASIS.....</b>	<b>9</b>
2.1 CURRENT DESIGN CONSIDERATIONS BASED UPON STEADY STATE EVALUATIONS.....	9
2.1.1 <i>Environmental forces</i> .....	9
2.1.2 <i>Actuators and Effective thrust</i> .....	12
2.1.3 <i>Control system and thrust allocation</i> .....	12
2.1.4 <i>Power generation</i> .....	12
2.1.5 <i>Static Capability plots</i> .....	12
2.1.6 <i>Environmental regularity numbers “ERN” and calculations</i> .....	14
2.2 NEW ADVANCED METHOD FOR DYNAMIC CAPABILITY ANALYSIS “DYNCAP” BY MARINE CYBERNETICS AND DP CAPABILITY LEVEL3 BY DNV GL .....	14
2.2.1 <i>Deriving the DynCap equations</i> .....	15
2.2.1 <i>Variation in environment and actuator time response</i> .....	15
2.2.2 <i>Lack of data for actual thrust response configuration</i> .....	15
2.2.3 <i>Need for equipment Dynamic Merit System.</i> .....	15
<b>PART 1 – ESTABLISH SYSTEM UNDERSTANDING, COLLECTION OF DATA .....</b>	<b>16</b>
<b>3 PROPULSION THEORY, REASONING FOR THRUST RESPONSE, TORQUE AND POWER RELATIONSHIPS.....</b>	<b>16</b>
3.1 GENERAL .....	16
3.2 PROPULSION THEORY, MAIN TYPES OF THRUSTER/PROPULSION CONFIGURATION.....	16
3.3 PROPELLER MODELLING AND CHARACTERISTICS.....	17
3.3.1 <i>Propeller Characteristics in general</i> .....	17
3.3.2 <i>Propeller efficiency</i> .....	17
3.3.3 <i>Thrust, Torque and Power relationships</i> .....	17
3.4 THREE MAIN TYPES OF PROPELLER CONTROL AND CHARACTERISTICS .....	18
3.4.1 <i>Fixed RPM and Variable Pitch</i> .....	18
3.4.2 <i>Fixed Pitch and variable RPM</i> .....	19
3.4.3 <i>Variable RPM and Variable Pitch</i> .....	19
3.4.4 <i>Alternative thrust arrangement</i> .....	20
3.5 THRUSTER DYNAMIC EFFECTS, (TORQUE, THRUST AND POWER RELATIONSHIP).....	20
3.5.1 <i>Shaft Dynamics</i> .....	20
3.5.1 <i>Accounting for gears</i> .....	21
3.5.2 <i>Motor/System Dynamics</i> .....	21
3.5.3 <i>Bollard pull and Effective thrust relationship</i> .....	23
3.5.4 <i>Dynamic Loss effects</i> .....	23
3.6 TORQUE/ SPEED AND POWER CONTROL SYSTEM FOR THE PROPELLER .....	24
3.6.1 <i>Control system handling of thrust loss, extreme conditions, ventilation etc. and avoiding transients and oscillations</i> .....	24
3.6.1 <i>Thrust control in general, resulting minimum response time for a given system from a controller perspective</i> .....	24

3.6.2	<i>System dynamics in general</i> .....	25
3.6.1	<i>Propeller speed, torque and Power summary</i> .....	25
3.7	MAXIMUM THRUST RESPONSE SEEN FROM A MECHANICAL PERSPECTIVE.....	26
3.7.1	<i>Speed variations and drive motor Power/torque curves</i> .....	28
3.7.2	<i>Example illustrating the Inertia, shaft speed and torque relations</i> .....	31
3.8	MAXIMUM THRUST RESPONSE SEEN FROM MAIN POWER GENERATION SYSTEM PERSPECTIVE.....	32
3.8.1	<i>Diesel electric systems</i> .....	32
3.8.1	<i>New technology, opportunity and challenges</i> .....	33
3.8.2	<i>Diesel electrical systems and different modes</i> .....	33
3.8.3	<i>Power management systems</i> .....	35
3.8.4	<i>Stability of main switchboard, frequency, volt etc</i> .....	36
3.8.5	<i>Power Generator and Electric consumers relationship</i> .....	37
3.8.6	<i>Diesel/Gas Engines:</i> .....	38
3.8.7	<i>Stored energy source to handle short term load variations as well as replacing running machinery</i> .....	44
3.8.8	<i>Resulting system dynamic load change capacity</i> .....	45
3.8.1	<i>Maximum dynamic load from thrusters and heavy consumers</i> .....	47
3.8.1	<i>Dynamic load above recommendations from generators, and use of accumulators for dynamic peak shaving</i> .....	50
3.9	MAXIMUM THRUST RESPONSE SEEN FROM THE VESSEL`S HIGH LEVEL CONTROL SYSTEM PERSPECTIVE.....	51
3.9.1	<i>Thrust control in a total system view</i> .....	52
3.9.2	<i>System capability and stability and maintenance perspective</i> .....	52
3.9.3	<i>“Human” expectations of response, Thrust generation and vessel movement</i> .....	52
3.9.4	<i>Various system providers, no clear lines of responsibility. (Several possible solutions but different views and agendas)</i> .....	53
3.10	EXPERIMENTAL RESULTS FROM MEASUREMENT OF THRUSTER RESPONSE FOR ACTUAL VESSELS .....	53
3.10.1	<i>Typical enquiry forms with question made for individual vessels:</i> .....	54
3.10.2	<i>Test Results</i> .....	60
3.10.3	<i>Discussions of the results</i> .....	61
<b>PART 2 – (PROPOSED METHODS)</b> .....		<b>62</b>
<b>4 USE THE MAIN PROPULSION MACHINERY AND THRUST RESPONSE RELATIONS. TO EVALUATE THE VESSELS DYNAMIC CAPABILITIES</b> .....		<b>62</b>
4.1	METHOD DESCRIPTION .....	62
4.1.1	<i>Method 1: Advanced method by use of dynamic simulation tools:</i> .....	63
4.1.2	<i>Method 2: Simplified method by use of standard load cases and thrust response times.</i> .....	63
4.2	DYNAMIC MERIT FACTOR FOR THE VESSEL, “D-ERN” .....	64
4.3	MAIN MACHINERY DYNAMICS AND PROPOSED MERIT FACTOR CATEGORIZATION.....	65
4.3.1	<i>Evaluation of thrust requirements and Thrust build up times</i> .....	65
4.3.2	<i>Proposed Thruster loading capacity classification index</i> .....	65
4.3.3	<i>Proposed Thrust Load Cases</i> .....	66
4.3.1	<i>Proposed main generator dynamic Load Capability classification Index.</i> .....	66
4.3.2	<i>Proposed early design stage mode evaluation system</i> .....	67
4.4	BRIDGING THE GAP OF TRADITIONAL STATIC DESIGN TOOLS AND MODERN DYNAMIC DESIGN TOOLS ....	69
<b>5</b>	<b>CONCLUSIONS</b> .....	<b>70</b>
<b>6</b>	<b>FURTHER WORK</b> .....	<b>71</b>
<b>REFERENCES</b> .....		<b>73</b>
<b>APPENDIX</b> .....		<b>75</b>
APPENDIX A	ENQUIRY RELATED TO PARTICIPATION IN RESEARCH PROJECT (COMPANY 1 AND 2) .....	75
APPENDIX B	ENQUIRY RELATED TO PARTICIPATION IN RESEARCH PROJECT (COMPANY 3) .....	75
APPENDIX C	RESULT FROM VESSEL 1.....	75
APPENDIX D	RESULT FROM VESSEL 2.....	75
APPENDIX D	PRELIMINARY RESEARCH PAPER .....	75
<b>APPENDIX D</b> .....		<b>I</b>

<b>PRELIMINARY RESEARCH PAPER .....</b>	<b>I</b>
<b>ABSTRACT .....</b>	<b>1</b>
<b>CONTENTS.....</b>	<b>1</b>
<b>INTRODUCTION.....</b>	<b>2</b>
<b>DP AND MANOUVERING SITUATIONS.....</b>	<b>2</b>
<i>Vessel manoeuvring capability .....</i>	<i>2</i>
<i>Resulting dynamic power request from thruster configuration.....</i>	<i>3</i>
<b>MAIN GENERATOR / POWER CONFIGURATIONS.....</b>	<b>4</b>
<i>Generator and main switch board configuration.....</i>	<i>4</i>
<i>Alternative configurations.....</i>	<i>6</i>
<b>MAIN MACHINERY DYNAMICS AND PROPOSED MERIT INDEX CATEGORIZATION.....</b>	<b>8</b>
<i>Proposed thruster loading capacity classification index .....</i>	<i>8</i>
<i>Proposed Thrust Load Cases .....</i>	<i>8</i>
<i>Proposed main generator dynamic load capability classification Index. ....</i>	<i>9</i>
<b>PROPOSED EARLY DESIGN STAGE MODE EVALUATION SYSTEM.....</b>	<b>9</b>
<b>CONCLUSIONS .....</b>	<b>10</b>
<i>Bridging the gap of traditional static design and modern time-domain simulations .....</i>	<i>10</i>
<b>REFERENCES.....</b>	<b>10</b>

## **TERMINOLOGY**

This thesis refer to sever other works done by other, formulas and equations from earlier performed work are in some sections included to point out relations. The reader is referred to the authors and the interested reader should consult the referred work for further details and explanations for formulas etc.

### **Abbreviations**

AP	Aft Perpendicular
CP	Controllable pitch
CPP	Controllable pitch propeller
DOF	Degree of freedom
DNVGL	DNV GL AS, Classification Company
DP	Dynamic positioning
FPP	Fixed pitch propeller
GNC	Guidance, navigation, and control
IMCA	International Marine Contractures Association
LOA	Length over all
LPP	Length between perpendiculars
ME	Main engine
MCR	Maximum Continuous Rating
MTC	Manual thruster control
PM	Pierson-Moskowitz (wave spectrum) or Position Mooring
PMS	Power management system
Q	Torque
QP	Combined torque/power
rps	Revolutions-per-second





# 1 INTRODUCTION

## 1.1 Project background

One of the challenges in ship design is to make sure that a vessel is able to perform its tasks in a safe and efficient manner by defining optimal vessel design with respect to hull, propulsion, thruster and main power configurations.

To select the right propulsion configuration and effects are crucial. The main propulsion system is normally designed according to service speed and draught requirements and the thruster according to expected resulting side force requirements.

Propulsion Requirements

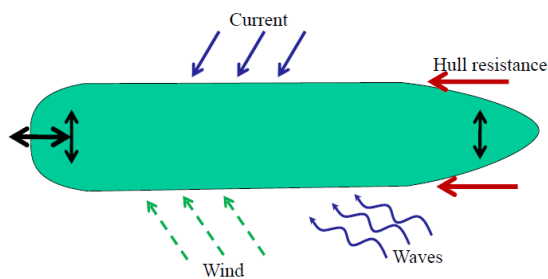

**Figure 1-1, Propulsion Requirements**

(Sketches taken from Lecture notes, HIALS Machinery System)

Ship resistance  
Typical "displacement hull"

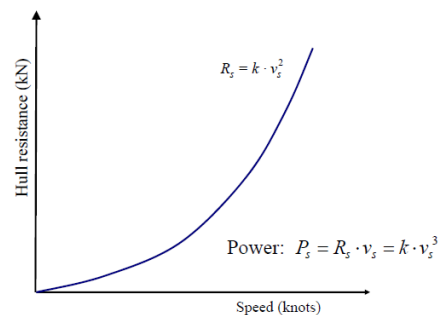

**Figure 1-2, Ship Resistance**

Control of the vessels movement is handled by several "layers" or hierarchy of levels of control systems interacting and working together, this is the same for manually operated vessels where the captain operates the handles and a DP operated vessel where a controller based upon sensor gives the orders.

Smogeli (2006) describes the control hierarchy of a marine guidance, navigation and control system might be divided into three levels and refers to Balchen et al. (1976, 1980); Sørensen et al., (1996); Strand, (1999); Strand and Fossen, (1999); Fossen and Strand (1999, 2001); Strand and Sørensen (2000); Lindegaard and Fossen (2001); Fossen (2002); Lindegaard (2003); Bray (2003) and Sørensen (2005)

- The guidance and navigation system, including local set-point and path generation.
- The high-level plant control, including thrust allocation and power management.
- The low-level thruster controllers.

This thesis will focus on the high level controller and specially the Thrust allocation ability for a vessel with a given main machinery configuration in various modes. But to understand the interactions between the systems the assignment will also study the propulsion and thruster system and its dynamic more in detail.

Pivano (2008) have in his work focused on thrust estimation and control of marine propellers and are linking this to the overall control system similar to earlier work done by several as Smogeli and Fossen mentioned above.

My work will not go in depth related to propeller control as ventilation, anti-spin, and loss control effects it will consider only normal operation and fully submerged propellers.

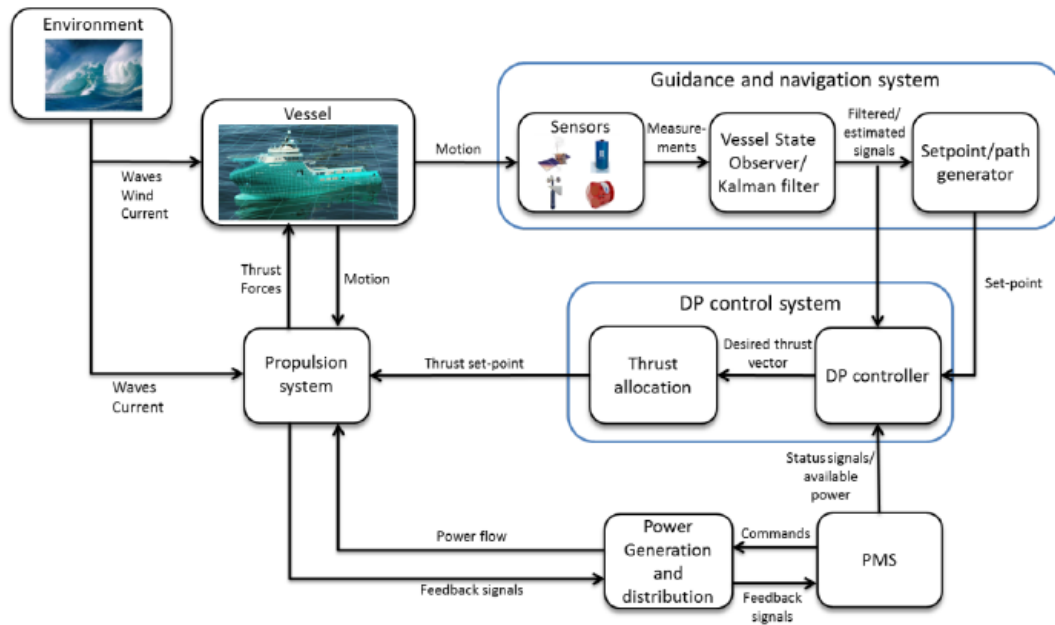

**Figure 1-3, Sketch of Marine vehicle control system Pivano (2008) and DNVGL-ST-0111 2016**

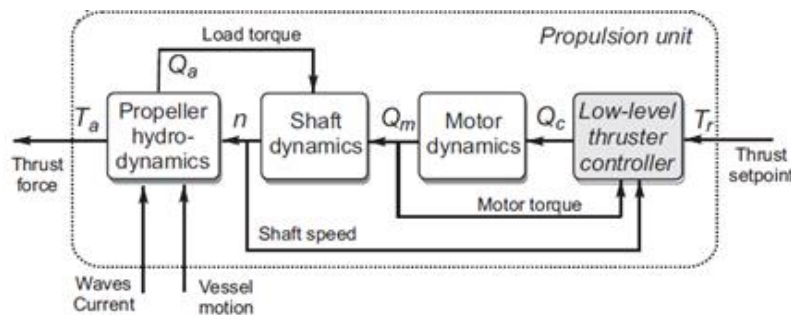
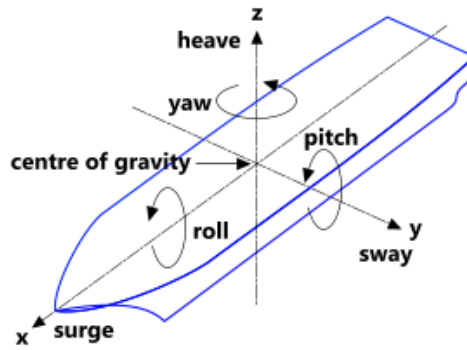

**Figure 1-4, Block diagram for vehicle control Smogeli (2006), Propulsion system**

In Smogeli PhD from 2006 he is also referring to and describing the main type of propellers types/systems used for side thrust and main propulsion. I will repeat some of this in this study to establish an understanding of the various power needs for the different applications.

Both Smogeli (2006), Pivano (2008, 2012) and Børhaug (2012) describe the various vessel motion variables and refer back to Fossen (94 and 2011) and several others.

But in short a marine vessel is moving in 6 degrees of freedom (DOF) and six independent coordinates are required to determine the position and orientation. These six different motion components are defined as surge, sway, heave, roll, pitch and yaw, Fossen (2011).



**Figure 1-5, 6-DOF**

The various DOF positions, orientations and corresponding velocities and accelerations for the vessels is defined in SNAME (1950) as presented by Fossen (2011)

DOF		Forces and moments	Linear and angular velocities	Position and Euler Angles
1	motion in the x direction (surge)	X	u	x
2	motion in the y direction (sway)	Y	v	y
3	motion in the z direction (heave)	Z	w	z
4	rotation about the x axis (roll)	K	p	$\phi$
5	rotation about the y axis (pitch)	M	q	$\theta$
6	rotation about the z axis (yaw)	N	r	$\psi$

**Figure 1-6, 6-DOF, SNAME (1950) notations as given in Bredhaug (2012)**

Bredhaug (2012) explain the different equations for motion control and coordinate transformation used by different tools but we will not go into details about this in this thesis.

To help you in the design phase you could use several tools to determine the static weather operational window where the vessel can maintain its speed, heading and position within some limits.

To establish a weather window, a static analysis is normally performed by balancing the maximum obtainable thruster force against a resultant mean environmental force due to wind, wave drift, current, and possible other loads.

Important assumptions and simplifications must be done to facilitate the analysis and the dynamic behaviour of the vessel and propulsion system is not considered, but allowed for by having a “margin”. IMCA M140 have a 15% dynamic Allowance, DNV ERN have 10% Dynamic allowance, In the New DNVGL-ST-0111 - Assessment of station keeping capability of dynamic positioning vessels Standard Level 1 uses 1.25.

To establish the plots indicated below the sum of the environmental forces given in IMCA/DNVGL standards acting on a vessels are calculated for several positions around the vessel to present the capability in a polar coordinate plot. These plots could of cause also be established for certain conditions not given by IMCA, but typical weather in a given port to help evaluate ferry regularity and wheatear window for a given location.

**Diving Support Vessel - DSV**

Dynamic Factor 1.25

Results: DP Capability L1 (9, 7, 5, 2)

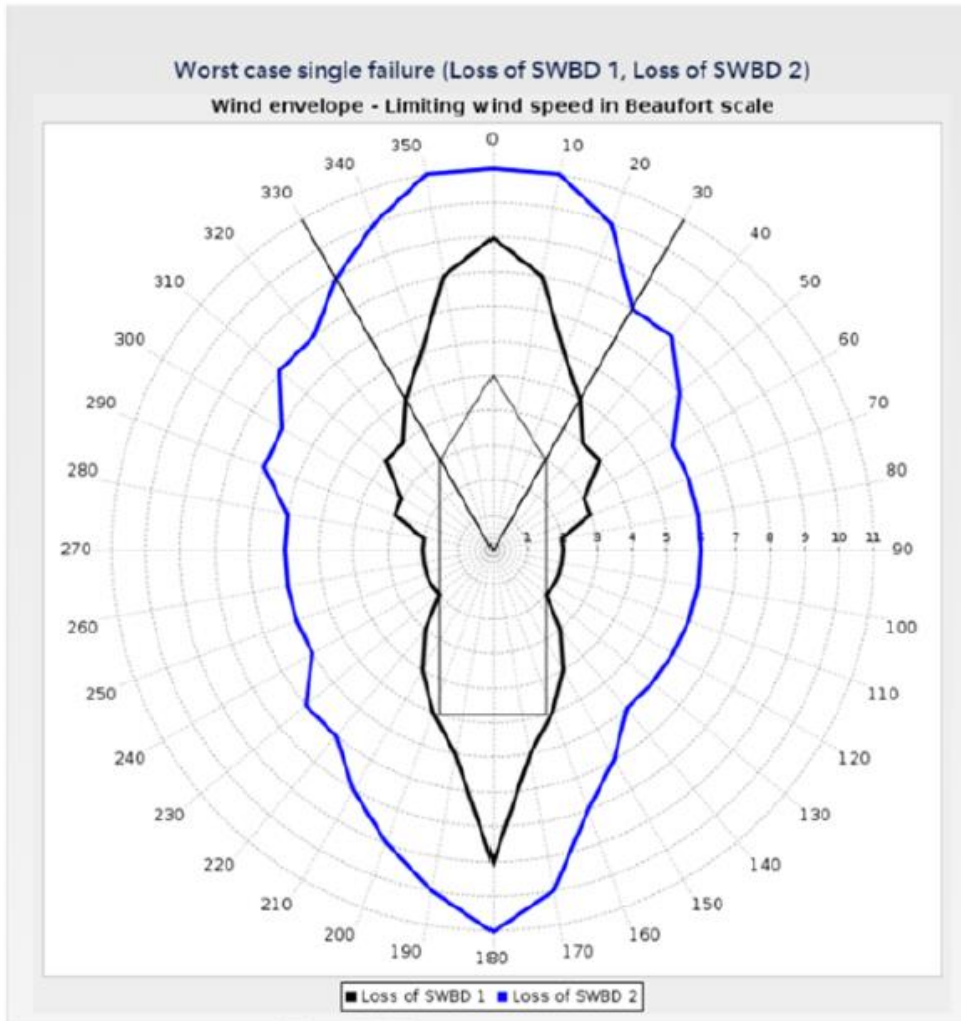

Figure 1-7, example of wind envelope from DNVGL DP Capability program

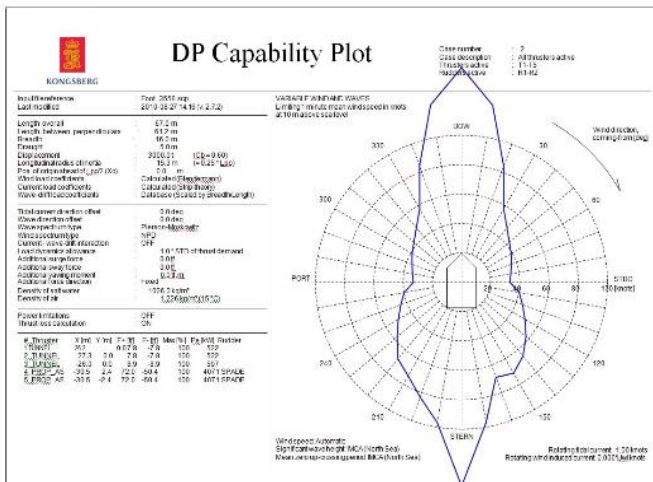

Figure 1-8, Example of Weather envelope made by Program from Kongsberg

Wind speed: 20.00 (m/s)  
Current speed: 0.50 (m/s)  
Significant wave height: 7.3 (m)

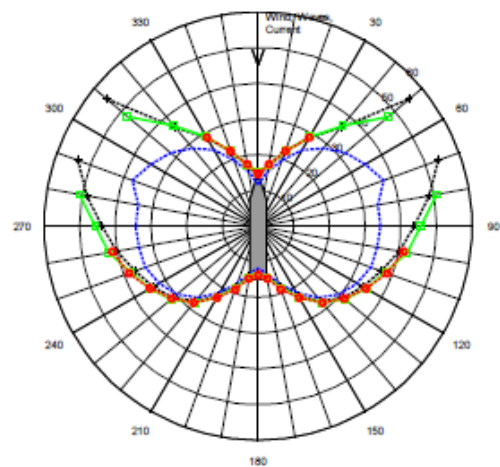

Figure 1-9, Example of Thrust envelope

The above illustrations is examples of the vessels capabilities after an equilibrium of environmental and thrust forces have been achieved (static pictures)

$$\mathbf{F}(\text{environment})+\mathbf{F}(\text{vessel thrust})=\mathbf{0}$$

The effect of dynamic weather or vessel motions and inertia and the propeller systems response time is not considered in these static analyses, but as described above accounted for by a dynamic factor.

Bredhug (2012) are studying the current standards shortcomings and are pointing out that they are based on non-vessel specific coefficients, thruster force rules of thumb coefficients and don't give specifications of how to account for the DP control system etc.

Bredhuag (2012) is touching upon that the thrust force could not be established immediately and that we need to encounter for forbidden thrust zones as well as the different thruster types Azimuth thruster with fixed pitch propellers that need to turn etc. and that it takes time to ramp up thrust forces.

In Bredhaug (2012) he is comparing the static DP CAP systematic given by Class and IMCA with the The Next Level DP Capability Analysis By Øyvind Smogeli, Nguyen Dong Trong, Brede Børhaug, Luca Pivano and indicate that this will be a better tool to get accurate understanding of the vessel behaviour.

DNVGL have lately issued their new Assessment of station keeping capability of dynamic positioning vessels Standard — DNVGL-ST-0111. This standard have a DP Capability Level 3 part that introducing a 3 degree heading limit and a 5 meter position limit.

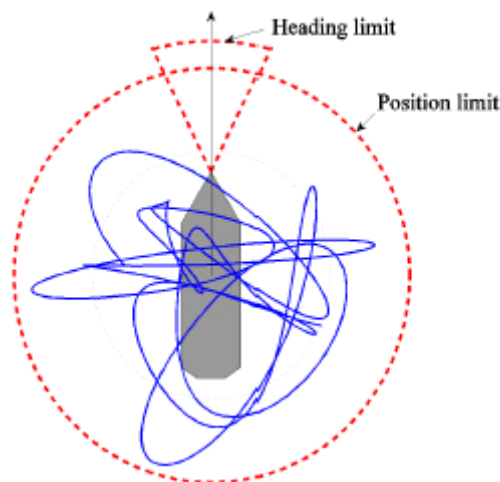

**Figure 1-10, Position and heading limits from the DNVGL-ST-0111**

To achieve accurate and trustworthy results from modern dynamic simulation tools you need to have your input and limitations correctly established.

But no formal criteria for thruster response requirements are given in the above listed publications or to my knowledge normally agreed upon in neither building specifications nor building contracts.

Equipment manufacturers would possible tend to like slow response and gradually build-up of thrust, due to maintenance and stability requirements etc. but are to my understanding not

clearly stating their preference/limits, while the owner in many cases would like to have faster response.

The Thrust Allocation module and the power module in the DynCAP tools are prepared for taking this into considerations but i have not found any good study related to this.

This is also indicated in the work from Bredhaug (2012) he is stating that to understand the azimuths turning time to build up of thrust is important, but from the evaluation in his section 9.7 Power it seems for me like he is only checking the static theoretical power availability and are not taking into considerations the main engine power setup and dynamic behaviour.

This thesis will focus in the relation between thrust build up times and combinations of load cases and compared this with the main generators capability.

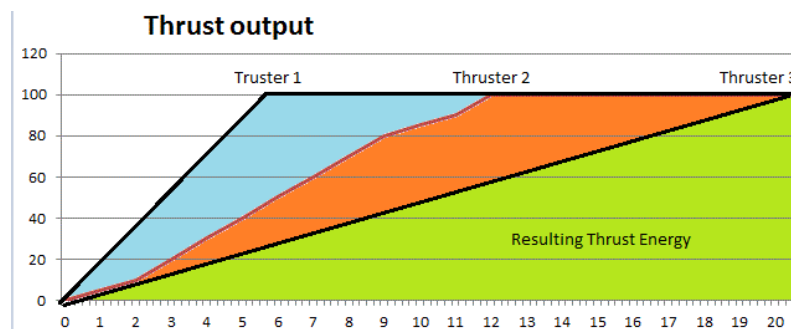

**Figure 1-11, Various thrust build up times**

We understand that the thruster’s dynamic behaviour will have effect on the dynamic behaviour of the vessel, but it is not equally clear that the thruster’s dynamic behaviour is highly dependent of the main machinery configuration and mode.

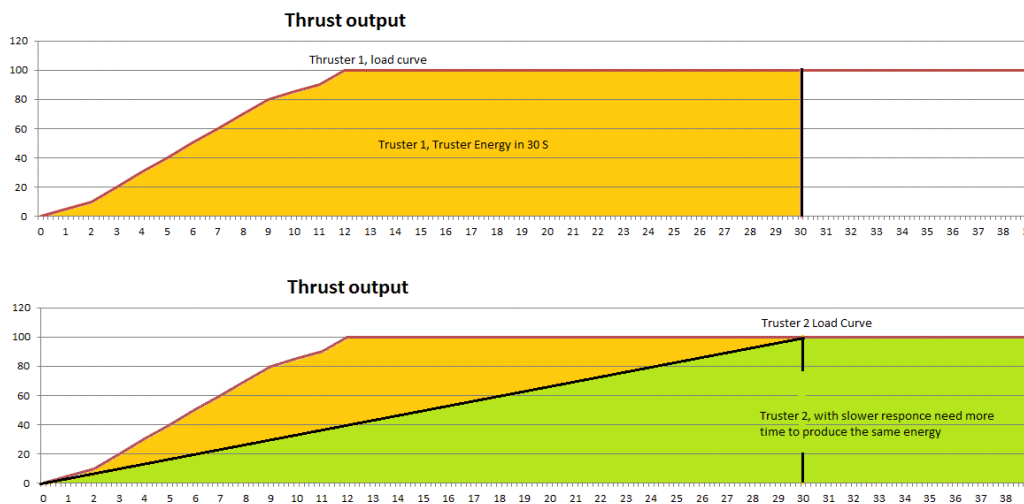

**Figure 1-12, Thrust energy time variations**

As indicated in the above figure different ramping times could result in differences of the dynamic capabilities of the vessels. The vessel to the left in the below illustration could maintain its position within some meters due to here quick response and build-up of counter forces and the vessel to the right with slower response will have a bigger footprint in the same weather, or in the event of losing one of its thrusters and need to allocate and build up thrust for remaining thrusters.

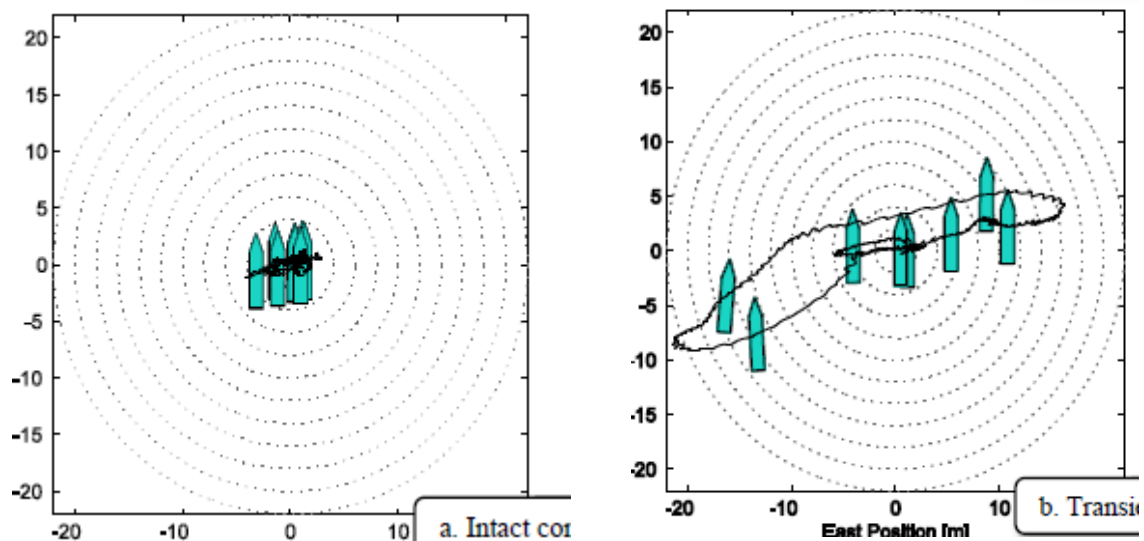

**Figure 1-13, Illustrations from Smogeli et. al [4] The next level DP**

The vessel to the right could be better in many ways, both related to stability of systems and maintenance etc. If the operation profile for the vessel accepts this bigger footprint this is perfectly fine, but if the vessel need to have a small footprint the dynamic of the various systems is important. This is of cause linked to the vessels movement and inertia and could also have effect on the fuel consumption etc.

When vessels are tested at trails, many of the parameters as the thrusters and main machinery catachrestic are fixed, and one of the few remaining parameters that could be adjusted is the thrust response time/curve. To adjust this could have implications for both the equipment, and the vessels machinery and power management system and built in blackout prevention systems etc.

The thrust response could be depending on several settings as power available signal from the PMS, to the drive settings and the control system and it is not always clear during commissioning who is the responsible to tune “total” system.

Lately as described in Bredhaug (2012) and as mentioned above there have been developed tools as the DynCap tool from Marine Cybernetics that takes the dynamic vessel, weather, system and thrust allocation into considerations but to have the correct input related to thrust curves you will need data from actual tuned vessel.

This study will try to investigate the relations between the different systems affecting the thrust build up curves and possible try to establish some guidance related to dynamic merits for thrusters, main engine and control system configurations and the vessel as such.

Hopefully we could by proposing some guide for expectations to the systems, and use these at an early design phase with tools like DynCap or other similar tools be better to predict the vessels behaviour. If we don't have these basic understanding established we risk using and thrusting these new tools with the wrong assumptions. This could in some cases be worse than not “knowing” the actual limit for the vessel.

## **1.2 Previous Work**

This study and my literature search of the selected topic have reviled that there have been done similar studies of the ships dynamic in the recent past. But they all have a slightly different perspective.

One of the closest linked works I have found is the “The Next Level DP Capability Analysis” By Øyvind Smogeli, Nguyen Dong Trong, Brede Børhaug, Luca Pivano. They propose an analysis tool “DynCap” as the next level of DP capability analyse and concludes in their study that the traditional ERN and IMCA M 140 have significant shortcomings and that their calculations shows a closer to real station keeping capability. This is supported by a Master Thesis by Børhaug B in June 2012.

Previous “supporting” work have been carried out on a wide range of themes some of the most important contributors in my view is Thor I. Fossen’s, Guidance and control of ocean vehicles (1994).

For description of low-frequency and wave-frequency motion Fossen – A nonlinear unified state-space model for ship manoeuvring and control in a seaway have been briefly studied and to understand the thrust allocation in general T. A. Johansen, T. I. Fossen, Control Allocation – A Survey, Automatic, 2013 could be consulted.

This work forms much of the theories for making a mathematical model of control of ship movements. Børhaug (2012) explains these relations in this will not be part of this thesis.

To better understand the propeller system and the control of marine propellers the PhD from Øyvind N. Smogeli "Control of marine propellers: From normal to extreme conditions." (2006); and the same with the PhD from Luca Pivano “Thrust Estimation and Control of Marine Propellers in Four- Quadrant Operations” (2008). Both of these has been studied and referred to at several points during this paper.

To better understand the Torque and power control the work done by Asgeir Sørensen and Øyvind N. Smogeli. "Torque and power control of electrically driven marine propellers." Control Engineering Practice 17.9 (2009) and the work done by Rakopoulos, Constantine D., and Evangelos G. Giakoumis. Diesel engine transient operation: principles of operation and simulation analysis. Springer Science & Business Media, 2009.

Work from several others are referred to and listed in the reference table in the end.

### **1.3 Problem formulation**

The thesis will be divided in two parts:

**Part 1** will investigate how this is handled today. Investigate relevant Propulsion, Main Machinery and Control theory. This part will also try to establish normal dynamic power/thrust times by interviewing and actual measurements on-board actual vessels. Establish “normal” Power/Time graphs from “signal” to actual thrust and investigate how this effect the thruster and the relation to the main machinery system.

**Part 2** will use the main propulsion machinery and thrust response relations found in Part 1 to evaluate the vessels dynamic capabilities and to develop a simplified methodology for selecting a normal range of thrust response times linked to the main machinery and modes (generators online). And propose a system enabling us to make a dynamic merit factor for the various equipment/system/vessel. Propose a simple early stage design method to ensure sound dynamic relations and to combine this input with programs as DynCap to establish some kind of Dynamic ERN number merit factor for the vessel something like

$D_{(5m/5deg, 10m/10deg, 15m/15deg, 20m/20deg)}$  ERN



## **1.4 Objectives**

From an environmental point of view all would like to run with as optimal engine configurations as possible, we need to realize that this could have effect on the dynamic response times and behaviour of the vessel.

The use of alternative fuel sources such as LNG as well as introducing accumulated energy as flywheels or batteries for dynamic peak shaving will also be briefly discussed.

When we understand the dynamic relations we more easily could propose the right size of an “accumulator” to help us handle the dynamic effects of rapidly changing loads. This could have a positive effect for the environment, vessel behaviour as well as maintenance needs and costs.

The objectives for this Master Thesis as such is of cause to try to learn more about the selected topic and possible establish some important relations that could be used by the industry to build better ships for their intended purpose and reduce uncertainties that that influence the end result.

This applies both for the early stage design phase as well as for the vessel specific full dynamic models.

## **2 BACKGROUND AND THEORETICAL BASIS**

### **2.1 Current design considerations based upon steady state evaluations**

It seems like most design offices today mostly make use of their experience database as well as steady state evaluation criteria's given in the traditional DP rules to select their thruster configuration.

Designs are often compared and weighted by their ERN numbers.

For the selection of main machinery system a static electric power balance sheet comparing the various modes are used and of cause evaluated according to the operation profile of the vessel to find the best possible combination of static power.

As the position keeping and manoeuvring operation is a dynamic operation by definition we need to understand the transient states both from the external environment as well as between the various consumers (force actuators) and generators on-board

As described above more advanced design tools are available, but to date often not used in the design phase.

#### **2.1.1 Environmental forces**

As mentioned above the environmental forces are dynamic but are to start with simplified in equations giving us a constant environmental in different levels.

Both IMECA M140 (2012) and the DNV GL Rules and new standard ST-0111 gives us guidance how to calculate these.

The following environmental forces are to be considered:

- Wind forces
- Wave forces
- Current forces

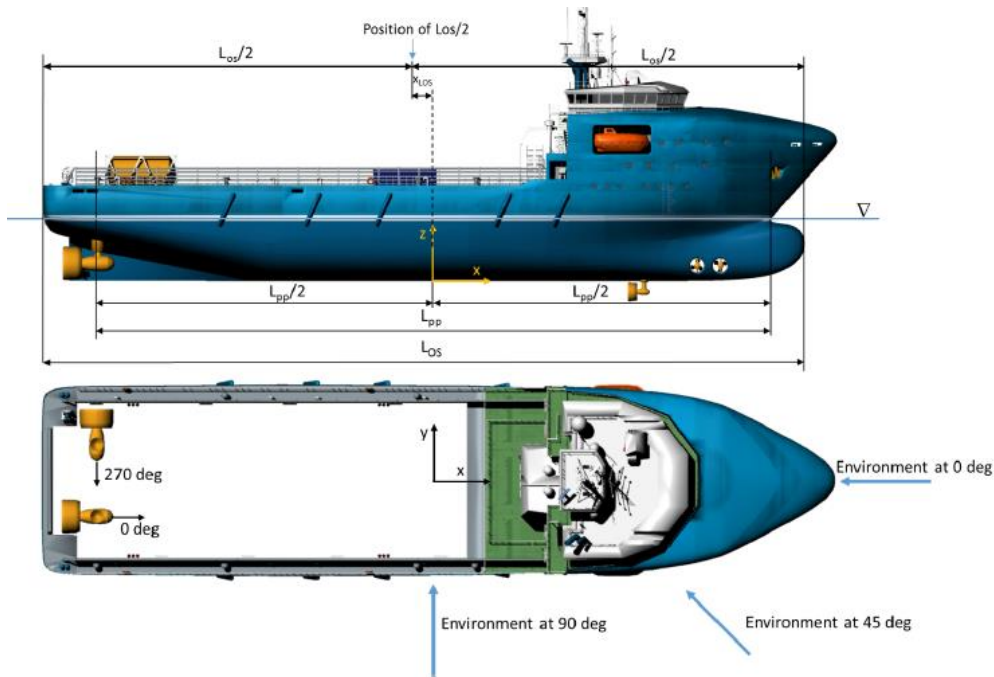

**Figure 2-1, Coordinate system figure from DNVGL-ST-0111**

### 2.1.1.1 Wind:

Reference is made to the DNVGL-ST-0111 - Assessment of station keeping capability of dynamic positioning vessels Standard. (July 2016). This standard describes the formulas that could be used to calculate the wind force in the X and Y direction as well as the moment the forces will result in for the vessel.

$$F_{X,wind} = \frac{1}{2} \rho_{air} V_{wind}^2 A_{F,wind} * (-0.7 * \cos(direction))$$

$$F_{Y,wind} = \frac{1}{2} \rho_{air} V_{wind}^2 A_{L,wind} * (0.9 * \sin(direction))$$

$$dir = \begin{cases} direction, 0 \leq direction \leq \pi, \\ 2\pi - direction, \pi \leq direction \leq 2\pi \end{cases}$$

$$M_{Z,wind} = F_{Y,wind} * \left( x_{L,air} + 0.3 * \left( 1 - 2 * \frac{dir}{\pi} \right) * L_{pp} \right)$$

**Figure 2-2, Wind Formulas from DNVGL - ST-0111**

where:

*Direction* = wind coming from direction

$A_{F,wind}$  = frontal projected wind area as from a picture in front view

$A_{L,wind}$  = longitudinal projected wind area as from a picture in side view

$x_{L,air}$  = longitudinal position of the area centre of  $A_{L,wind}$

$\rho_{air}$  = air density = 1.226 kg/m<sup>3</sup>

### 2.1.1.2 Current

The forces from current loads shall be calculated using the following formulas:

$$F_{X,current} = \frac{1}{2} \rho_{water} V_{current}^2 B * draft * (-0.07 * \cos(direction))$$

$$F_{Y,current} = \frac{1}{2} \rho_{water} V_{current}^2 A_{L,current} * (0.6 * \sin(direction))$$

$$dir = \begin{cases} direction, & 0 \leq direction \leq \pi, \\ 2\pi - direction, & \pi \leq direction \leq 2\pi \end{cases}$$

$$M_{Z,current} = F_{Y,current} * \left( x_{L,current} + \max \left( \min \left( 0.4 * \left( 1 - 2 * \frac{dir}{\pi} \right), 0.25 \right), -0.2 \right) * L_{pp} \right)$$

**Figure 2-3, Current Formulas from DNVGL - ST-0111**

where:

$A_{L,current}$  = longitudinal projected submerged current area as from a picture in side view  
 $Direction$  = current speed coming from direction  
 $B$  = maximum breadth at water line  
 $draft$  = summer load line draft  
 $x_{L,current}$  = longitudinal position of the area center of  $A_{L,current}$   
 $\rho_{water}$  = water density = 1026 kg/m<sup>3</sup>

### 2.1.1.3 Waves

Wave drift forces shall be calculated using the following formulas:

$$F_{X,wave} = \frac{1}{2} \rho_{water} g H_s^2 B * h(direction, bow_{angle}, C_{WL_{aft}}) * f(T'_{surge})$$

$$F_{Y,wave} = \frac{1}{2} \rho_{water} g H_s^2 L_{OS} * (0.09 * \sin(direction)) * f(T'_{sway})$$

$$M_{Z,wave} = F_{Y,wave} * \left( x_{Los} + \left( 0.05 - 0.14 * \frac{dir(direction)}{\pi} \right) * L_{OS} \right)$$

**Figure 2-4, Wave Formulas from DNVGL - ST-0111**

where:

$H_s$  = significant wave height  
 $L_{OS}$  = longitudinal distance between the fore most and aft most point under water  
 $L_{pp}$  = length between perpendiculars  
 $x_{Los}$  = longitudinal position of  $L_{OS}/2$   
 $bow_{angle}$  = angle between the vessel x-axis and a line drawn from the foremost point in the water line to the point at  $y = B/4$  (ahead of  $L_{pp}/2$ ) on the water line, so the  $bow_{angle} = \arctan(B/4/(x_{max} - B/4))$ ,  $x_{max}$  is the longitudinal position of the foremost point in the water line,  $x_{B/4}$  is the longitudinal position of the point in the water line at transverse position equal to  $B/4$   
 $C_{WL_{aft}}$  = water plane area coefficient of the water plane area behind midship =  $A_{WL_{aft}} / (L_{pp}/2 * B)$   
 $A_{WL_{aft}}$  = water plane area for  $x < 0$   
 $direction$  = waves coming from direction.

### 2.1.2 Actuators and Effective thrust

The DNVGL-ST-0111 describes various types of actuators and their resulting effective thrust taking into consideration several factors, as inlet, ducting mechanical efficiency, ventilation. These various effects are in more depth described in Smogeli (2006).

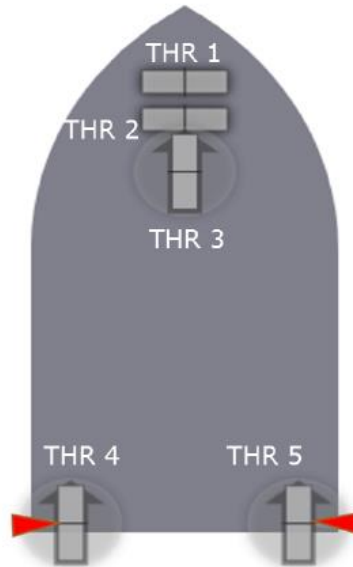

**Figure 2-5, Thrust actuators and their forbidden zone vectors**

### 2.1.3 Control system and thrust allocation

As mentioned above the control system consists of several layers, It is simply stated in the standards that the control system should calculate necessary actuator forces and their direction to control the vessel position and heading taking into consideration eventual forbidden thrust zones for actuators.

### 2.1.4 Power generation

Calculations shall be in accordance with the vessel static power consumption balance, and it is stated that 10% of electrical generated power shall be reserved for hotel and consumers not part of the thruster system for each mode.

The DNVGL rules DNVGL-RU-SHIP-Pt6 Ch3 have requirements related to redundancy and capacity of generators and have in their guidance note stated that “Particular attention should be paid to starting conditions of thruster motors, especially with one generator out of service. Thrusters should have arrangements to prevent large start currents and voltage drop during the start sequence”.

### 2.1.5 Static Capability plots

There are several standards and tools to create Capability Plots, DNV GL have now an open tool that could be downloaded and started in <https://my.dnvgl.com/> (<https://dpcapability.azurewebsites.net>) There are also other tools available and common for these tools is that you give the vessel parameters needed by the above given formulas as well as the actuators position and limitations and you are able to create a static capability plot similar to the one indicated below.

The Wind envelop indicate the balance of the vessels capabilities from the thrusters to balance the sum of the wind, wave and current acting on the vessel. It doesn't state anything about the

time or distance it will need to build up this state of equilibrium, but the various standards have a dynamic factor to take this into consecration in the example below this is 1.25.

**Default Vessel DP Capability App - Diving Support Vessel**  
**Worst Case Single Failure: Intact case, Loss of SWBD 1, Loss of SWBD 2**  
 Dynamic factor: 1.25

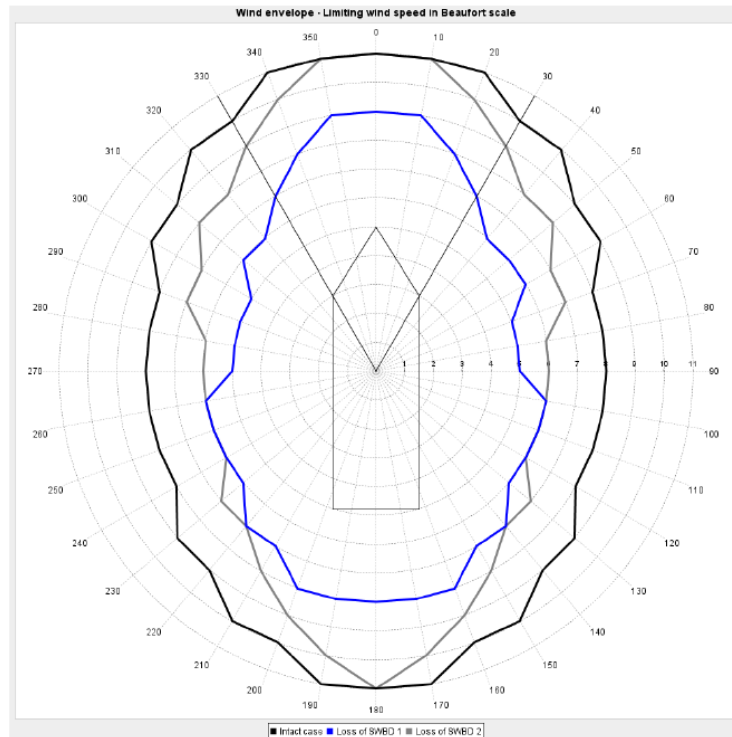

Figure: Worst case single failure results, Beaufort scale

**Figure 2-6, Typical static capability plot**

Table: DP Capability numbers and Beaufort scale wind, wave height and wave period						
Beaufort number	DP Capability number	Beaufort description	Wind speed [m/s]	Significant wave height [m]	Tp [s]	Current [m/s]
0	0	Calm	0	0	NA	0
1	1	Light air	1.5	0.1	3.5	0.25
2	2	Light breeze	3.4	0.4	4.5	0.50
3	3	Gentle breeze	5.4	0.8	5.5	0.75
4	4	Moderate breeze	7.9	1.3	6.5	0.75
5	5	Fresh breeze	10.7	2.1	7.5	0.75
6	6	Strong breeze	13.8	3.1	8.5	0.75
7	7	Moderate gale	17.1	4.2	9.0	0.75
8	8	Gale	20.7	5.7	10.0	0.75
9	9	Strong gale	24.4	7.4	10.5	0.75
10	10	Storm	28.4	9.5	11.5	0.75
11	11	Violent Storm	32.8	12.1	12.0	0.75
12	NA	Hurricane force	NA	NA	NA	0.75

**Figure 2-7, Environmental Condition used by DNVGL program and the DNV GL DP Capability Standard ST-0111**

## 2.1.6 Environmental regularity numbers “ERN” and calculations

Based on the capability plots the position keeping ability of the vessel could be established according to the concept of the environmental regularity numbers, hereafter called ERN.

The ERN represents the static balance of environmental forces and thruster output. ERN is quantified with its basis in the weather statistics of a chosen location in the North Sea with a given ERN Wind and Wave statistic table listed in Rules for classification: Ships — DNVGL-RU-SHIP-Pt6Ch3

The format of the ERN is a series of 4 numbers, ranging from 0 to 99. Like ERN(a, b, c, d) and is normally listed in the register information of the vessel.

The is extracted from the capability plots at the incidence angle of forces which causes the maximum load on the vessel. The four numbers shall represent:

- a: represent optimal use of all thrusters
- b: represent minimum effect of single-thruster
- c: represent the maximum effect single-thruster failure
- d: represent the worst case failure mode

The ERN is intended to reflect a “worst case situation”, which for mono-hull vessels normally will be the situation with the weather on the beam. The ERN will be based on this situation regardless of the vessel's ability to select other headings in operation.

For further information reference is made to DNVGL-RU-SHIP-Pt6Ch3 - Navigation, manoeuvring and position keeping.

Several vessels have ERN(99,99,99,99) but they could have highly variable capabilities to establish a new balance between the vessels reaction forces and the environmental forces after a failure or change in weather.

So a more advanced approach to evaluate the vessels position keeping abilities should possible be used. This is also pointed out by Børhaug (2012).

## 2.2 *New advanced method for dynamic capability analysis “DynCap” by Marine Cybernetics and DP capability level3 by DNV GL*

To get more insight and understanding of the vessel's actual manoeuvring and position keeping capability we need more insight of the actual dynamic performance of the vessels main machinery and movement behaviour. And we will need to performance time-domain evaluation and simulations to establish the vessels capability.

The new simulation and modelling tools as the DynCap program from Marine Cybernetics and the DP capability Level 3 from DNV GL tries to assess the effect of dynamics on the position keeping performance.

Relevant dynamics are:

- vessel dynamics
- environmental load dynamics
- actuators dynamics
- Main machinery configuration and resulting dynamic capabilities in various modes
- external force dynamics
- DP and other control system dynamics.

The earlier work by Smogeli et. al (2012) The next level DP Capability Analysis» By Øyvind Smogeli, Nguyen Dong Trong as well as later work done by Luca Pivano and Brede Børhaug is referred to in this chapter.

### **2.2.1 Deriving the DynCap equations**

From Thor I Fossen's "Guidance and control of Ocean Vehicles" and later work we find the basis for modelling marine vehicles. Later work like DynCap - "the next level dynamic dp capability analysis" by Pivano, L, Øyvind Notland Smogeli, and Vik, B. (2012). Have used time domain calculations to bridge the gap between a static analysis and to better understand the vessels capabilities.

Brede Børhaug has in his thesis from 2012 compared the two methods and have also explained the vessel motion variables and the equation of motion of a vessel i water, which according to Fossen (2011) is the governing model for vessels in water.

The program to my understanding takes into consideration modelling of the vessel in the marine environment with Hydrodynamic forces and moments as well as kinematics, Newton and Lagrangian Mechanics and Rigid-Body Dynamics

Børhaug has also shown the mathematical relationship between the static equations for forces and the equations of motions used in time domain calculations in the DynCap program.

For further detail the reader is encouraged to read his work and the work referred therein.

### **2.2.1 Variation in environment and actuator time response**

Even if we now have a tool where we could calculate and simulate the vessels dynamic behaviour with changed environmental forces, or result of loss of one or several actuators resulting in movement of the vessel before a new equilibrium could be established.

We still need to do some assumptions as we don't have the actual complete system and its limitation before the vessel is completed and we could perform testing on board as described in the DNV GL ST – 0111.

### **2.2.2 Lack of data for actual thrust response configuration**

As described later in this assignment we don't have good figures for response time and resulting trust build up times for the various thrusters. These responses are dependant of several factors and are not given before the vessel is completed and tuned during sea trail.

And as earlier pointed out there is to my knowledge not a standard that you could refer to, and you are in many cases dependent on several manufacturers of systems and equipment

### **2.2.3 Need for equipment Dynamic Merit System.**

As the dynamic response times are poorly covered by rules and regulations and are not commonly identified in building specifications etc. it is my understanding that the industry needs a new simplified system for evaluating vessels during early design as well as could be used as input to more advanced time domain dynamic simulation tools.

To perform full “DynCap” analysis for the vessels with all its equipment, control systems and relations programmed will of course be one way. This will be difficult and time consuming in an early design perspective.

We need some simple guides for response times, and we need to establish a simple dynamic merit factor system, possible as simple as to have three to four levels of response times, effect of thrusters according to size position/moment of vessel etc. This is what I will propose in Part 2

## **PART 1 – ESTABLISH SYSTEM UNDERSTANDING, COLLECTION OF DATA**

### **3 PROPULSION THEORY, REASONING FOR THRUST RESPONSE, TORQUE AND POWER RELATIONSHIPS**

#### **3.1 General**

In this section we will study propulsion theory for various types of propellers and systems and how this is linked when it comes to propulsion speed, torque and thrust.

#### **3.2 Propulsion theory, Main types of thruster/propulsion configuration**

As indicated by Smogeli (2006) the actual propeller thrust  $T_a$  and torque  $Q_a$  are influenced by many parameters. Thrust and Torque can in general be formulated as functions of the shaft speed in revolutions per second (rps), time-varying states  $x_p$  (e.g. pitch ratio, advance velocity, submergence), and fixed thruster parameters  $\theta_p$  (e.g. propeller diameter, geometry, position) Smogeli (2006) have defined the following equations:

$$T_a = f_T(n, x_p, \theta_p),$$

$$Q_a = f_Q(n, x_p, \theta_p).$$

$$P_n = 2\pi n Q_n$$

The functions may of course also include thrust and torque losses due to several factors as ventilation, in and out of water effects, and dynamic flow effects. These effects will not be studied in detail in these theses.

Smogeli (2006) describes the three main types of propellers and their control, pitch controlled CPP with constant speed, speed controlled fixed pitch propellers FPP and consolidated controlled CCP where both the shaft speed and pitch can be controlled.

Smogeli (2006) further states that since the desired thrust can be produced by a number of combinations of shaft speed and pitch, this can be formulated as an optimal control problem and further states that optimal control of CCP is mainly relevant for transit operation. And refer to several works treating e.g. Schanz (1967), Winterbone (1980), Beek and Mulder (1983), Parsons and Wu (1985), Bakountouzis (1992), Chachulski et al. (1995), Fukuba et al. (1996), Morvillo (1996), Young-Bok et al. (1998), and Whalley and Ebrahimi (2002), and an overview given in Ruth et al. (2006). For more background information.



### 3.3 Propeller modelling and Characteristics

#### 3.3.1 Propeller Characteristics in general

Propellers are, with the exception of tunnel thrusters, usually asymmetric and optimized for producing thrust in one direction. The propeller characteristics will therefore depend on both the rotational direction of the propeller and the inflow direction. Smogeli (2006) and Pivano(2008) explains the four quadrants of operation of a propeller and their relationship.

#### 3.3.2 Propeller efficiency

Smogeli (2006) describes several effects that need to be evaluated related to the propellers efficiency. The presence of a hull close to a main propeller affects the propeller efficiency in several ways and Smogeli (2006), refers to e.g. Lewis (1989). The DNVGL ST- 0111 also point to hull shape, inlet angels and ducting of propellers as well as ventilation effects.

#### 3.3.3 Thrust, Torque and Power relationships

Smogeli (2006) point out that due to the working principles of the propeller, the thrust and torque are closely coupled. From an investigation of the effect of roughness on open propellers, Lerbs (1952) showed that for a given propeller, a change  $\Delta KQ$  of  $KQ$  implies a proportional change  $\Delta KT$  of  $KT$ , i.e.: where  $c_t$  is a constant. This implies that  $KT$  and  $KQ$  can be linearly related

Smogeli (2006) refers to full-scale experimental performed by Zhinkin (1989), that show that this relationship is stable for a large range of propeller operating conditions, including varying advance ratios, in waves, and for oblique inflow.

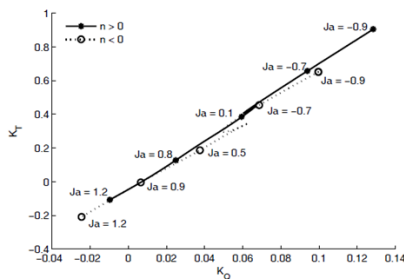

Figure 2.5: Relationship between  $K_T$  and  $K_Q$  for the Wageningen B4-70 propeller in the range  $-0.9 < J_a < 1.2$ .

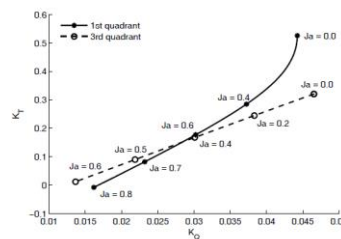

Figure 2.6: Relationship between  $K_T$  and  $K_Q$  for the Wageningen K4-70 propeller with 19A nozzle in the range  $0 \leq J_a < 0.86$ .

#### Figure 3-1, $KT/KQ$ curves from Smogeli(2006)

It is pointed out that Zhinkin (1989) only considered the first quadrant of operation and that for other applications and possible ducted propellers need to take into consideration that this might not be correct and should be accounted for by the control system.

The Power relation is directly linked to the Torque in a steady state, the effective thrust is of cause a function of the efficiency of the system and its operational conditions. The power/torque curve is for a thruster with variable speed also dependant of the inertia of the shafts and the inertia of the propeller in water and the change of speed (acceleration of the propeller)

For the load cases later described in this thesis the Power requirements are simplified.

### 3.4 Three main types of propeller control and Characteristics

#### 3.4.1 Fixed RPM and Variable Pitch

A thruster with fixed rpm and variable pitch, is a thruster that normally rotates at a given rpm and the variable thrust is obtain from varying the pitch ratio( $x_p$ ).

These thrusters are normally banned from being started up with a pitch setting much different from zero. Resulting in quite flat power P/ Torque curve up to the desired revolution level, and then you increase the pitch at constant speed increasing the P/Q.

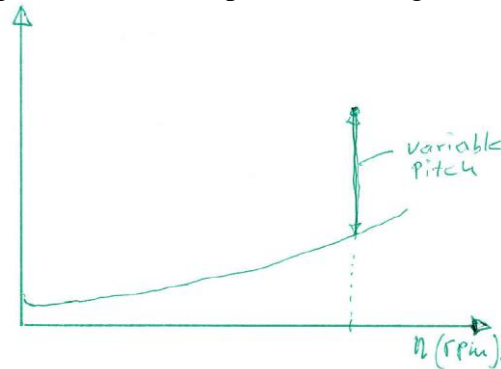

**Figure 3-2, Power/Torque diagram for fixed RPM and variable Pitch**

The thrusters with fixed RPM and variable pitch could be directly driven by diesel engines, or by electric motors.

As these thrusters will rotate with a constant speed, the starting arrangement for the electric motors is normally conventional star delta or auto transformer arrangements.

These starting arrangements are adjusted to avoid to high electrical starting currents and moments for the equipment, and are calculated based on the inertia of the system and the maximum moment/current that is acceptable.

The research article by Garg and Tomar, J Electr (2015) explain the various start up methods and discuss start up times.

In the tests on board one of the vessel found in Appendix we find that their 600kW thrusters requires about 100kW running at intended speed with zero pitch.

As these thrusters are started independently before a manoeuvring operation initiates, the high dynamic current/power needed to overcome the inertia during spin up of the thruster is seldom any problem, but will need to be encounter for.

We also find that these thrusters have a lower dynamic load variation during manoeuvring due to the fact that they are already running at their intended speed and you only change the pitch and variation from 100kW to 600kW in our test vessel example.

These running thrusters will also have a damping effect for other load variations in the electric system on-board the vessel as they represent a rotating mass.

The above effects will be explained a little more in detail later in the report.

### 3.4.2 Fixed Pitch and variable RPM

A thruster with fixed pitch and variable RPM, is a thruster that change its thrust by variation of the speed and rotation direction. These thrusters are normally driven by a frequency converter system (drive) enabling them to easy to change speed and direction.

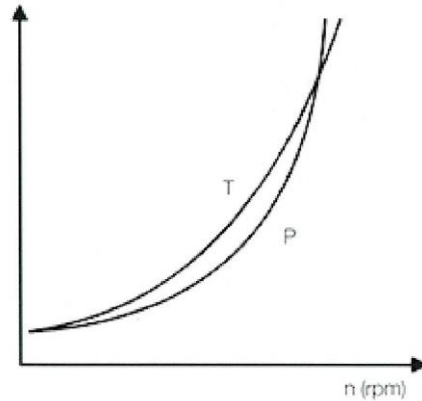

**Figure 3-3, Power/Torque diagram for fixed pitch and variable RPM**

These thrusters will not have a liner power / Torque curve related to revolution speed, the curve tend to be quite steep close to the maximum operation torque and power and the control system need to take this into consideration.

As these thrusters will change the speed they will also have to overcome the inertia forces for a dynamic manoeuvring picture, making them a little more complex to model. Due to their nature and drive system they will not represent a damping effect in the same way as a thruster that runs with constant speed.

These thrusters will have the full range of power variations from about 0 kw and will have the dynamic changes related to overcome the spin up of the rotating mass of the thruster in addition.

If these thrusters are built with short acceleration times they could due to the inertia forces have high power demand also in the dynamic range speeding up the thruster. More research should be made with actual load cases and variations to find normal dynamic power curves for these thrusters.

### 3.4.3 Variable RPM and Variable Pitch

For these thrusters we have two control parameters, the shaft speed and the pitch angle. This enables the thruster to have high pitch and low RPM at part loads and this might have a positive effect on the power consumption in some applications.

The P/n curve could be designed by varying these parameters to best fit the purpose for the thruster.

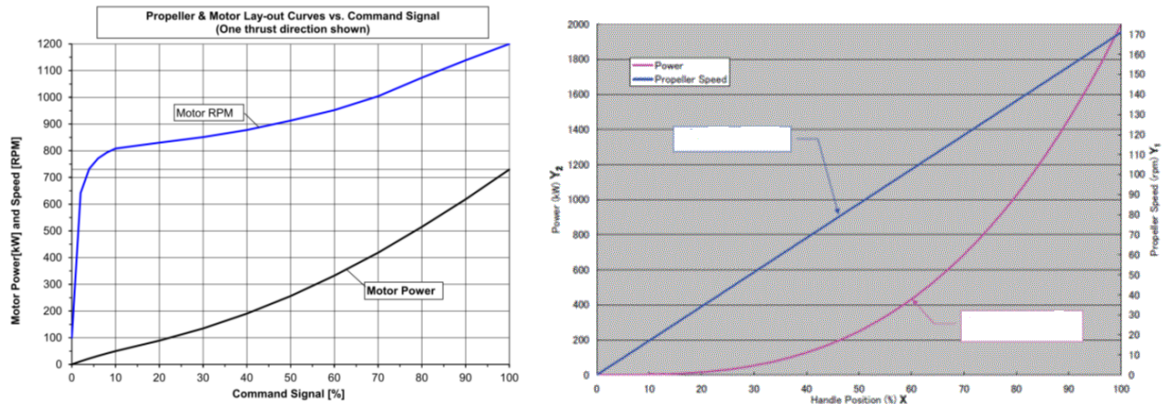

**Figure 3-4, Power/Torque diagram for variable pitch and variable RPM**

We find that different manufacturer have different philosophies when it comes to their curves, some quite quickly increase the speed of the propeller and then adjust the pitch and revolution to have a more linear power and thrust curve and other seem to increase the speed and pitch linearly with the result of a less linear form of the power curve.

This is a complex system and you need to have control of several parameters in your control systems, but it also gives you great flexibility.

### 3.4.4 Alternative thrust arrangement

We also have several other thruster types as water jets and Voight Snider, these have not been studied in this thesis. But both of them could to my understanding shift their thrust direction rapidly. I have not studied their power curves as they are not frequently used for bigger vessels.

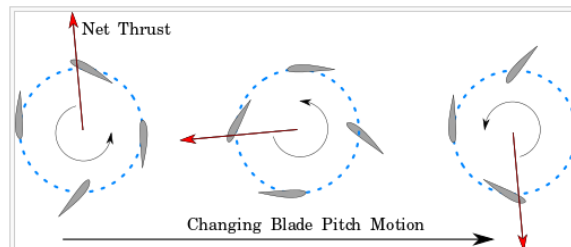

**Figure 3-5, Cyclorotors (Voight Snider) illustration**

## 3.5 Thruster dynamic effects, (Torque, Thrust and Power relationship)

Smogeli (2006) explains and take into considerations the dynamic effects for a thruster by considering the propeller motor, shaft and also by flow dynamics.

### 3.5.1 Shaft Dynamics

Smogeli (2006) states that the torque balance for the propeller shaft is written:

$I_s \dot{\omega} = Q_{mp} - Q_a - Q_f(\omega)$ , where  $Q_{mp}$  is the motor torque inflicted on the propeller shaft,  $I_s$  is the moment of inertia for the shaft, propeller, and motor,  $\omega$  is the shaft angular velocity, and  $Q_f(\omega)$  is the shaft friction. The friction may for most applications be viewed as a sum of a static friction or starting torque  $Q_s$  and a linear component:  $Q_f(\omega) = \text{sign}(\omega)Q_s + K\omega$  where  $K$  is a linear friction coefficient.

He also states that friction is assumed to be more significant on small thrusters typically used on underwater vehicles and in experimental setups, than on large thrusters used on surface vessels.

Smogeli (2006) further refer to Wereldsma (1965) and Parsons and Vorus (1981).

And states that propeller torque should in general also include an added mass term due to hydrodynamic forces. The added mass will depend on propeller shaft speed, advance velocity, and propeller submergence, and extensive model knowledge is required in order to include such terms. Neglecting the added mass will give a reduced rotational inertia, and hence faster dynamics. If the necessary model knowledge is available, the added mass could be included in  $I_s$ .

In the example below the inertia for the propeller is given by the thrust manufacturer as a constant, and it is stated that this is the inertia in water. My understanding is that they are giving a inertia of the propeller in water at max operation speed.

### 3.5.1 Accounting for gears

Many electrically driven propulsion units are equipped with one or two gearbox between the motor and the propeller shaft. The motor torque and speed at the el motor relates to the propeller torque and speed according to the gear ratio and the effect of internal friction in addition for the el motor torque.

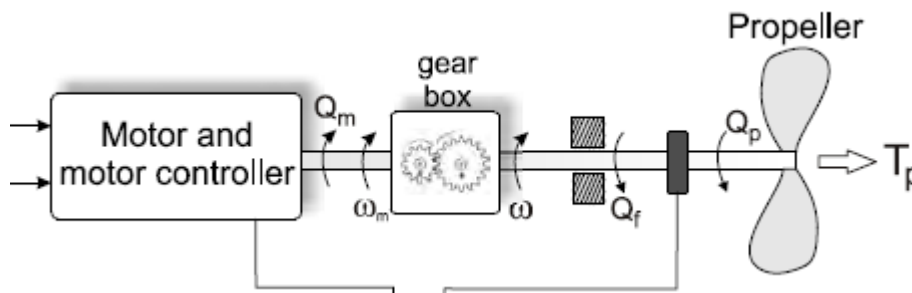

Figure 3-6, Illustration of a thruster system, Smogeli (2006)

### 3.5.2 Motor/System Dynamics

#### 3.5.2.1 Electric motor

Depending on your thruster catachrestic and type described above, the selected starter system and control system the electric motor could behave differently.

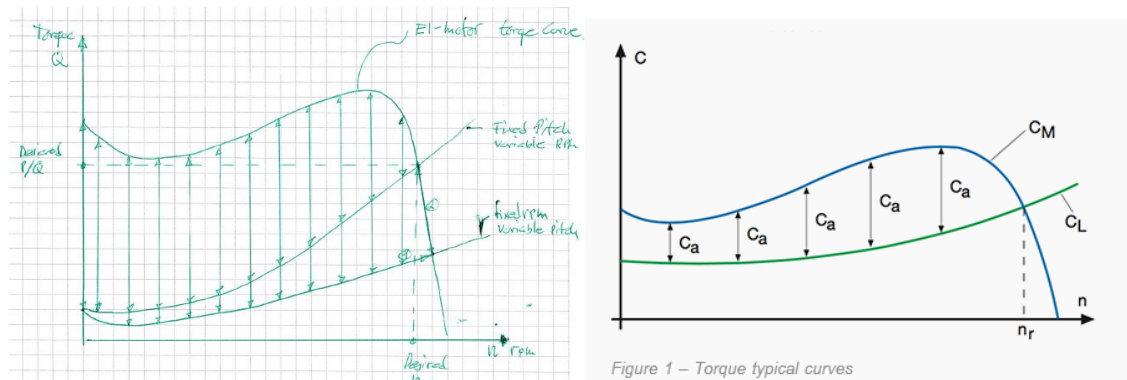
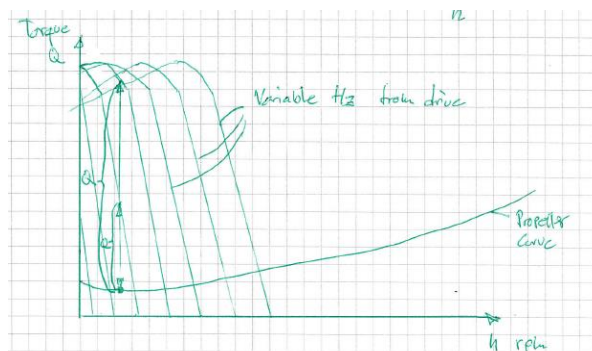

Figure 3-7, Typical EL-Motor Torque/rpm curve with different propeller curves

As explained above if you have a directly started motor, or a star delta or auto trafo starter you will end up at a given point on your motor el motor curve based on the catachrestic of your thruster and the torque is changed by changing the pitch resulting in a somewhat bigger electric lag resulting in increased torque. A electric motor running these thrusters is not controlled and have his fixed catachrestic and could normally for short periods deliver much higher torque than nominal up to about 2,3-2,9 times ref. Garg and Tomar, J Electr (2015)

For thrusters where you use frequency converters both the motor speed and torque is controlled by means of motor currents and motor fluxes with high accuracy and you might in the control system set a commanded torque and speed limits.



**Figure 3-8, Illustration of motor curve controlled by frequency converter**

The capacity of the drive gives you the maximum torque, if the drive is adjusted to the max power for the thruster at a given operation the torque limit for the drive is normally a little above. But you could of cause have much “stronger” drives that could if not controlled properly result in high acceleration torques if not limited.

The motor power  $P_m$  is given by:  $P_m = Q_m 2\pi n_m$ , where  $n_m$  is the motor speed. The rated (nominal) torque and power for continuous operation of the motor are denoted  $Q_N$  and  $P_N$ . The corresponding rated motor shaft speed  $n_N$  is given from:  $P_N = Q_N 2\pi n_N$ .

Smogeli (2006) states that the maximum torque  $Q_{max}$  and power  $P_{max}$  for the motor are usually set to:  $Q_{max} = k_m Q_N$ ,  $P_{max} = k_m P_N$ , where  $k_m$  typically is in the range of 1.1 – 1.2 and make refers to (Sørensen et al., 1997).

### 3.5.2.2 Starting/breakaway torque demand

All mechanical equipment will normally also have a starting breakaway torque requirement, and the control system need to take this in to consideration.

### 3.5.2.3 Diesel engine

As mentioned above a diesel engine could also directly drive the thrusters, or it could be the drive motor for generators.

I will come back to the diesel motor later in this thesis but as it could be used directly I will also mention it in this section.

It is in several theses it is stated that a diesel engine could be modelled in a similar way as the electric motor. And (Blanke, 1994) states that the diesel engine power is proportional to the fuel flow.

Smogeli (2006) explains that according to Blanke (1981), the diesel engine dynamics may for control design and propulsion performance evaluation be approximated by a time constant  $T_m$  and a time delay  $\tau_m$ . The diesel engine transfer function becomes:  $Q_m(s) = \frac{e^{-s\tau_m} K_y}{s T_m + 1} Y$  (s) where  $s$  is the Laplace operator,  $K_y$  is the motor torque constant, and  $Y$  is the fuel index (governor setting).

Smogeli (2006) further point out that  $Q_{cm}$  in is given by  $Q_{cm} = K_y Y$ , where  $Y$  is the control signal from the diesel controller. The diesel engine power is proportional to the fuel flow Blanke (1994). From Blanke (1981), the time constant is empirically found to be:  $T_m \approx 0.9 \cdot 2\pi n_m$  and the time delay can be approximated by half the period between consecutive cylinder firings. A diesel engine with  $N$  cylinders rotating at speed  $n_m$  rps then has the time delay:  $\tau_m \approx 12nmN$

The above does not to my understanding take into consideration the challenges the engine manufactures have related to rapid heat changes, and the challenges related to build up and down turbo pressure etc. during dynamic operation of the engines.

And will come back to these challenges in Item 4.8

### 3.5.3 Bollard pull and Effective thrust relationship

When the vessel is stationary such that  $V_a = 0$ , and the thruster motor is operated at its max continuous rating, the thruster is said to be in the bollard pull condition.

Smogeli(2006) explain the bollard pull thrust, torque, power, and shaft speed relations and the steady-state rotational dynamics and the power lost in static and linear friction as well as the mechanical efficiency  $\eta_m$

This should ideally be accounted for by the control system but it is also explain that in industrial applications, a constant mechanical efficiency is usually assumed, this could possible underestimate the friction losses for lower propeller speeds

The DNVGL ST-0111 states that in ideal conditions i.e. propeller deeply submerged, no wind, waves or current present a propeller produces thrust and torque according to:

$$T_{Effective} = T_{Nominal} \beta_T \quad T_{Nominal} = \eta_1 \eta_2 (D \times P)^{2/3}$$

Where  $T_{Effective}$  is the effective thrust,  $T_{Nominal}$  is the nominal thrust and  $\beta_T$  is the thrust loss factor.

### 3.5.4 Dynamic Loss effects

As noted above the propeller could based on its running situation have several effects depending on several factors. The maximum thrust is normally given for ideal conditions. The control system will also have to interpret and control the thruster in these variable situations.

Thrust loss is defined as any deviation of the thrust and torque from the nominal values. The effect of the thrust losses may be expressed by thrust and torque reduction coefficients as given in the above equations.

Smogeli (2006) have divided these loss effect in two main groups

1. Losses that mainly affect the propeller loading,

2. Losses that mainly affect the propeller wake.

He states that the hydrodynamics of a propeller affected by thrust losses is highly complex, and each of the mentioned thrust loss effects deserves a detailed study. He describes how this affects various types of propellers and configurations and how this must be accounted for by their control systems.

The DNVGL ST-0111 is simpler, it states that losses are to be corrected for and are giving simplified factors for Mechanical efficiency and efficiency factor for actuators, inlet and outlet factors of tunnels, and states how Ventilation losses could be calculated.

As these loss effects will to my understanding will not affect all thrusters at the same time, I have not taken this into consideration in my load pattern. But for a vessel operating in extreme conditions this should be evaluated. How this is simulated and reflected in the modern time domain simulation programs I am not sure of, and should be further investigated.

### 3.6 Torque/ Speed and power control system for the propeller

In order to avoid commanding excessive torque or power from the thruster motor, a torque limiting function is proposed included in the control system. Smogeli(2006) explains that as an alternative to the modified combined torque/power controller formulations it is possible to specify three control regimes explicitly: speed control for low shaft speed, torque control for medium shaft speed, and power control for high shaft speed.

He also discusses and proposes solutions for having inertia and friction compensation scheme is implemented in the control system for the thrusters

#### 3.6.1 Control system handling of thrust loss, extreme conditions, ventilation etc. and avoiding transients and oscillations

The control system must also ensure that mechanical wear and tear is kept to a minimum and limits the power oscillations and peak values. This will of course also have input to what how fast it is possible to operate the thruster and build up effect ensuring robust performance.

#### 3.6.1 Thrust control in general, resulting minimum response time for a given system from a controller perspective

As described the thrust control system could consist of several controllers and could have several regimes and inputs related to various effects end signals ref. below illustration.

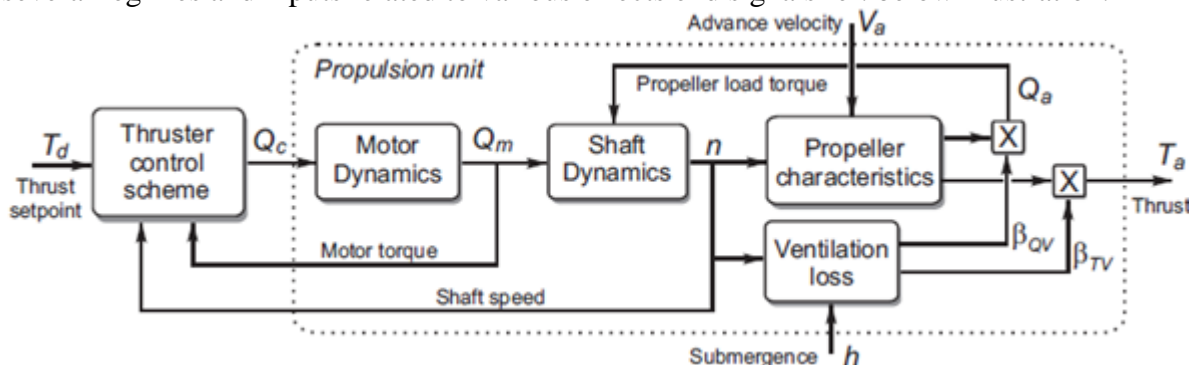

**Figure 3-9, Relation block diagram from Smogeli (2006)**

In addition to the local thrust controller with its limitations it will normally also communicate with the higher level dynamic vessel controller DP system.



Due to control speed and bandwidth Smogeli (2006) states that you could achieve significantly better positioning and tracking performance with improved low-level thruster controllers and makes reference to (Sørensen et al., 1997; Strand, 1999).

He also point out that for the DP control system, it is the mean and slowly varying values of thrust that are important: the oscillations in thrust induced by waves and wave-frequency vessel motion do not normally affect the vessel motion significantly.

The control systems for thrust controls in various situations are quite complex and are not covered in this part interesting readers should consult Smogeli (2006).

### **3.6.2 System dynamics in general**

As understood from the above propeller and thruster system for a marine vessel is quite complex. There are several effects to be aware of designing your control system for the vessel in general and for the individual thrusters.

On a higher level design stage we need to account for the whole system, we possible don't know what type of propeller that will be selected, we could rather easy find out the static forces needed to keep the position in a given environment. But if we should take into consideration the dynamic of the vessel with all it systems it starts to be complex.

As there are several different manufacturers normally delivering equipment to a vessel, it is in a design phase not easy to know the various limitations in control systems and resulting dynamic power demands etc.

You could typically have a control system for your thruster pitch system and one for the rpm control, you could have several different types of thruster designs and response curves, possible a thrust control or DP control system from a different manufacturer not fully understanding the limitations of the thruster control system. A power management system from a third manufacturer possible with some kind of built inn black out prevention system at first level giving power limitation signals to the drives or tripping unessential loads (possible the second level is built into the drives and is activated by reduced Hz) various amount of running machinery with its inertia resulting in a damping effect and the generator and diesel engines governor control system.

Ideally you should have a control system or a model encounter for all of these effects; this is difficult especially in an early design phase.

I will in the next chapter with the above knowledge try to generalise and simplify to try have some general understandings of typical limitations that are common for most systems.

### **3.6.1 Propeller speed, torque and Power summary**

AS we have learned from the above chapter there are several effects governing the propeller effect and torque. And we have several thruster types and operation modes.

In general we know that we have a propeller curve with increasing power requirements with increased revolution and pitch. And based on the drive line for the motor we could have several ways of controlling the speed, torque and ramping times.

### 3.7 Maximum thrust response seen from a mechanical perspective

If we study the thruster, it is in most cases built up of one or two 90 degree gears with a pinion and a crown wheel. Both the gear wheels and the thruster shafts will be affected by the variation condition the thruster operate in and how the control system controls its pitch and speed variations

We have learned above that the propeller in a dynamic environment experience effects that will change the thrust and torque, and Smogeli (2006) states that it is normally to have a torque limit for a frequency converter at approximately 1.1 to 1.2.

For a directly driven thruster we have noting limiting the torque except from the pitch system and this could be a mechanically/hydraulic challenge to operate with sufficient speed to limit the possible torque peaks.

Based on this it is important that we realise the mechanical limitations of the thruster with regards to torque and load variations, my focus will be on the torque/power side and just indicate the lower limits of ramping times.

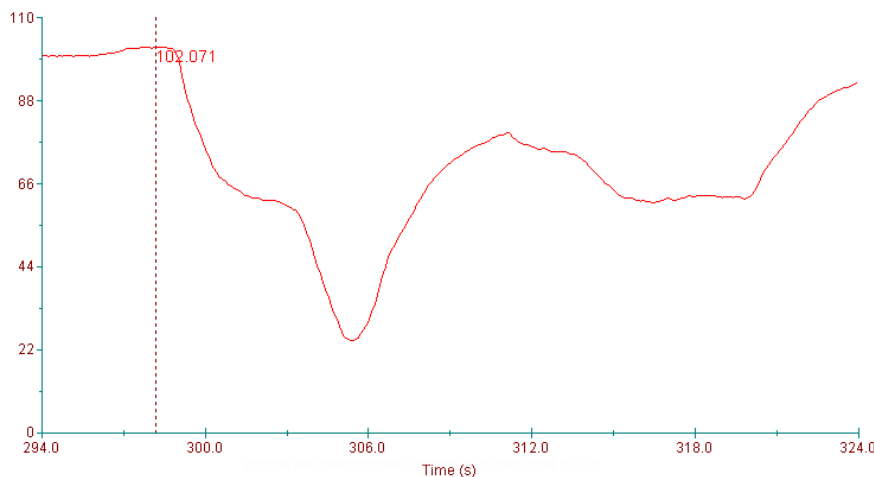
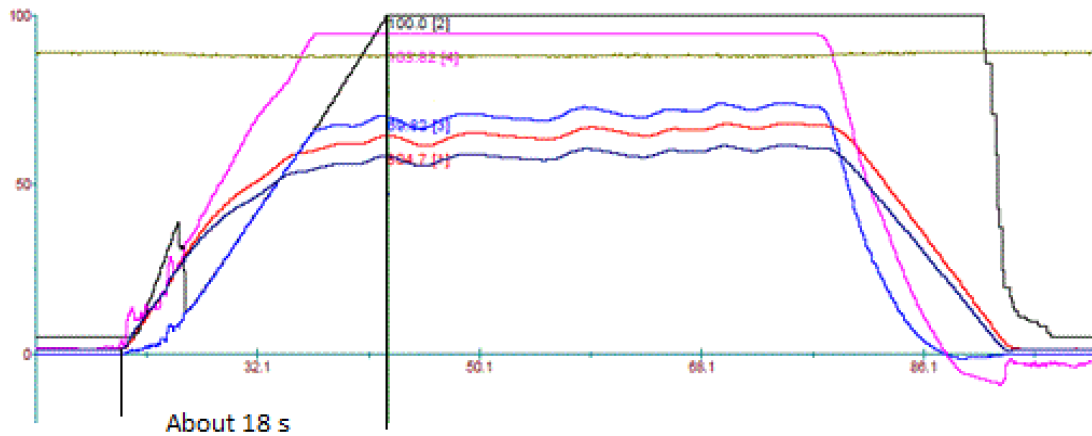

**Figure 3-10, Torque limiting curve**

The above figure is a torque curve logged during a steering gear test for a supply vessel where the thruster experience variations of inflow angles and speed due to the rotation of the vessel and the torque is increased to about 102% before the control system are reducing the torque and rapidly drops it down to about 22% before start building thrust again.

A frequency converter are able to limit the torque much more rapid than the pitch system, we should remember that this is measured torque from the electrical side and the electric motor have a relative big inertia that could result in higher torques in the thruster shaft system than the 102% indicated above.

The below illustrations indicates thrusters with different normal ramping times in a bollard pull situation.



**Figure 3-11, Thruster example 1, ramping times**

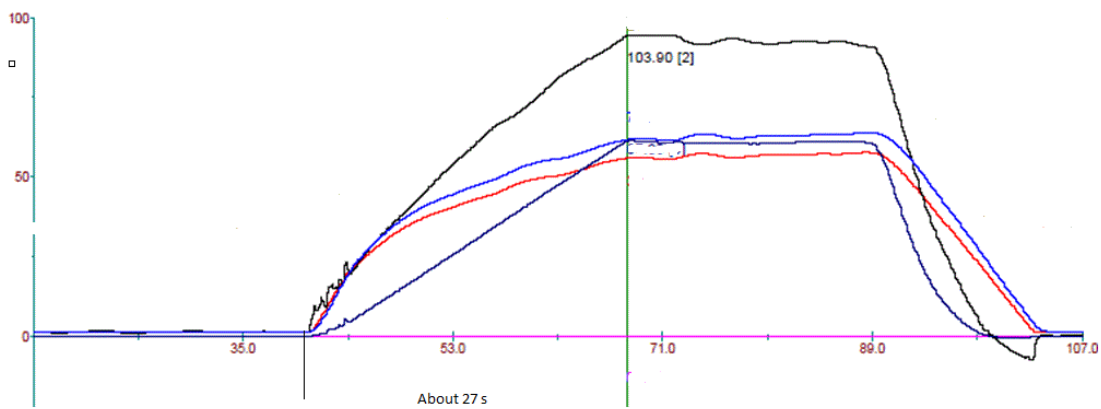
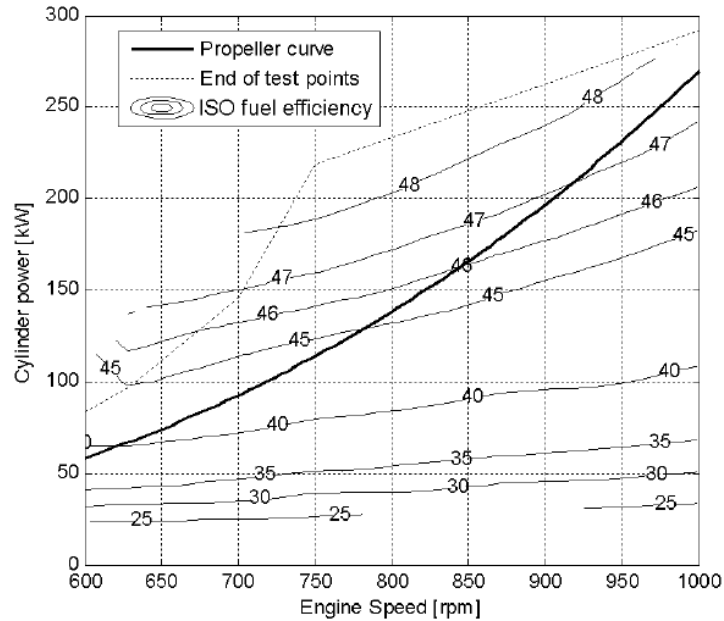

**Figure 3-12, Thruster example 2, ramping times**

The above illustrations indicates thrusters with different ramping times, the reasoning for the different curves could be several, control system settings, mechanical limitations, maintenance related or as we will discuss later dynamic power available from the generator side.

The frequent load variations due to changing inlet angles and velocity of water as well as the revolving propeller in various velocity zones, ventilation and how the control system is tuned will of cause have an effect of the mechanical and maintenance situation for the propeller.

As I am looking for the power variations in the bigger picture during manoeuvring operations I will focus on the maximum load and the speed control related to inertia and maximum moments.

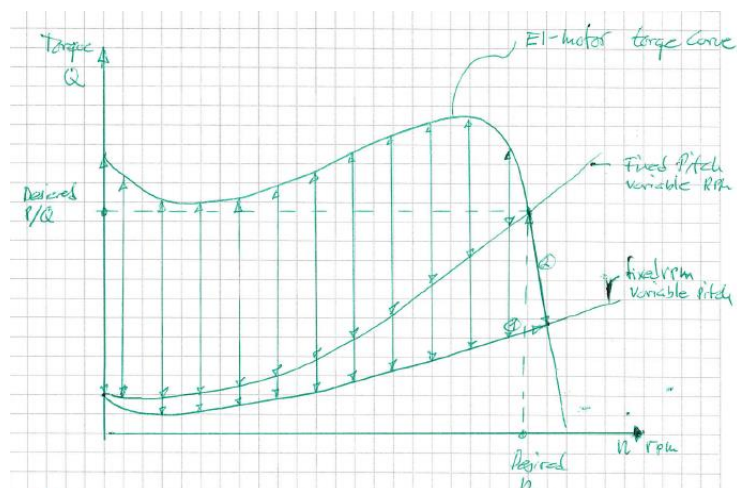

**Figure 3-13. Illustration of a Propeller P/D curve giving the system curve for a given system**

### 3.7.1 Speed variations and drive motor Power/torque curves

The torque curves are varying for different electromotor, and are of cause also affected by the start-up method for the electro motor. The moment curves are very steep at the operation point, but is illustrated here a little more angular. This implies that the torque increase very rapidly if there is a change between the system RPM (change of load) and the RPM tying to be obtained by the electromotor.

According to ref. Garg and Tomar, J Electr (2015) It is not uncommon to have electromotor and power system feeding the electromotor able to give 2.2 to 2.9 times the nominated Power / Torque in short periods (As indicated by the motor curve being much higher than the crossing point of the system curve.)



**Figure 3-14, Indicating a EL motor Start-up Curve with two different propellers indicated**

When you start an electromotor by use of changing the frequency by use of a frequency converter, you will change how fare in “front” of the system your field and resulting actually torque curve is. From the above illustration we find that if you are not careful you might have very high torques during start up and variation speeds. This is of cause dependent of the

drives capacity, and as the drives are normally ordered according to the maximum capacity of your system max moment plus possible 1.1- to 1.2 as Smogeli (2006) has indicated as the torque limit this might not be a problem but if you have a bigger drive you will for sure need to take care of this.

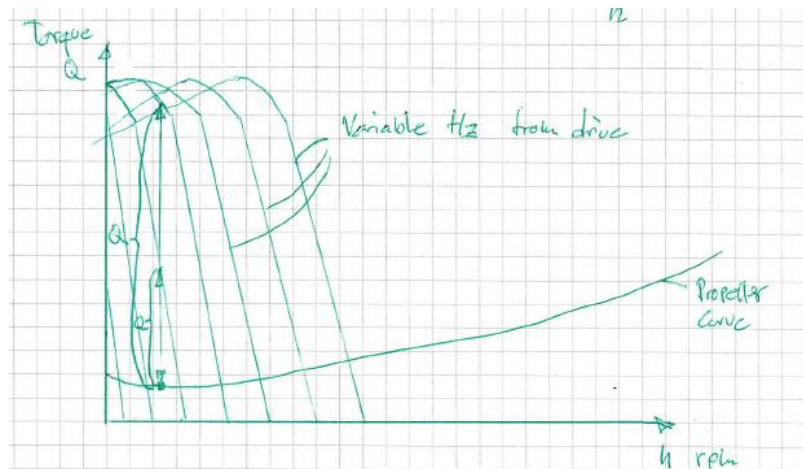

**Figure 3-15, Indicating an EL motor Start-up Curve when the frequency is altered by a Hz converter, the torque could be set to a upper limit to have control.**

The difference between the torque given from the electromotor and the propeller curve will give us the acceleration moment and it is important that there is a torque control built in to the system ensuring that we have control of this during speed variations and rapid load changes.

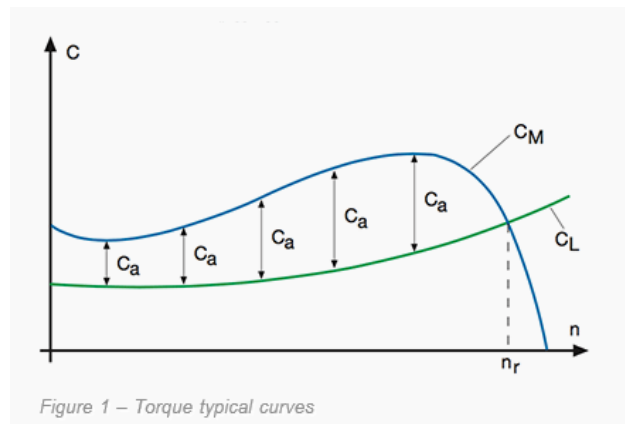

**Figure 3-16, Typical conventional EL-Motor start up Torque curve and a torque curve for a given system**

After defining the maximum acceleration moments and the propeller curve for your system as well as knowing the inertia of your system with the propeller in water you could calculate the minimum acceleration times for your system.

As the thruster manufacturers don't give us much details related to added mass and variation in the propeller inertia in water, we often have a fixed inertia for a submerged propeller and we might use the below formula to calculate needed acceleration times.

$$t_a = \int_0^{n_0} \frac{2 \times \pi \times (J_M + J_L)}{60} \times \frac{dn}{(C_M - C_L)}$$

**Figure 3-17, General formula for calculating starting times**

JM and JL in the above formula is the inertia for the motor and system, we should also remember that you will have to account for the gears and variation in revolutions for the various parts this is not included in the above formula

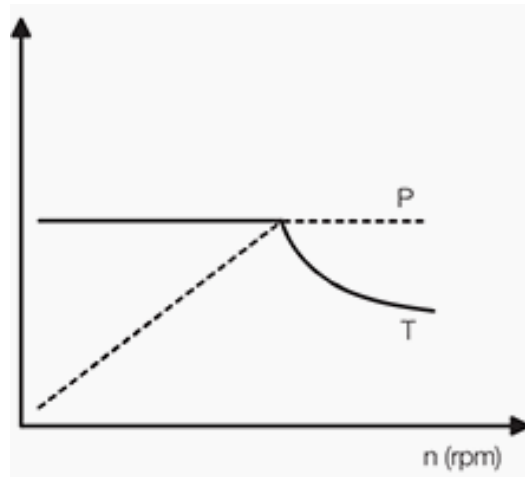
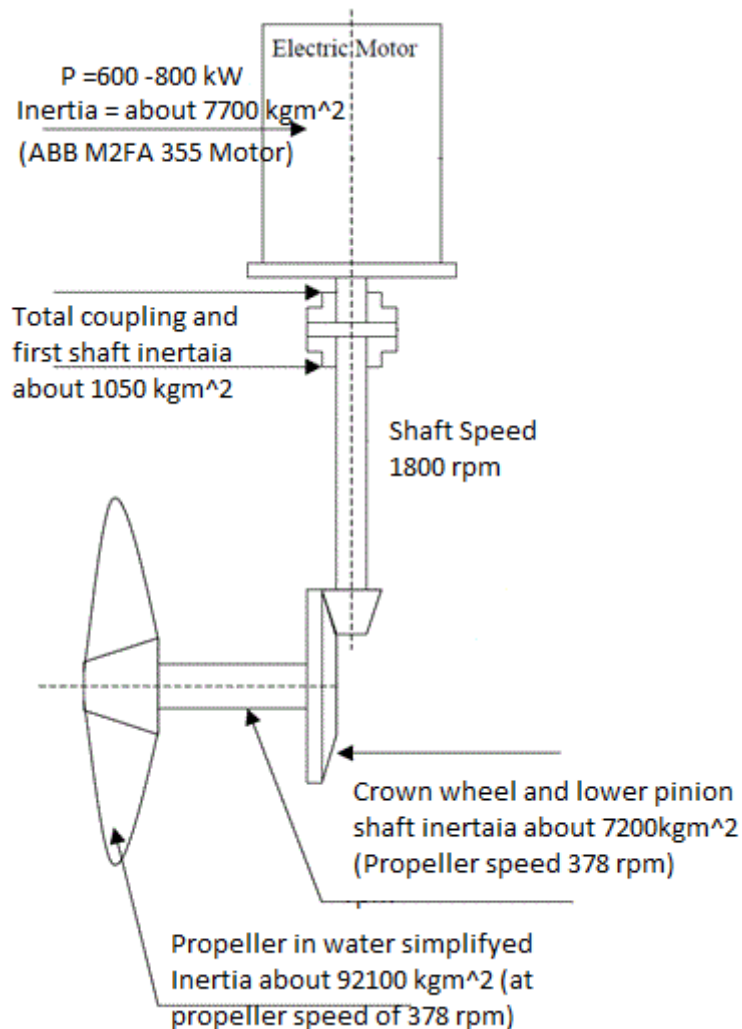

**Figure 3-18, Depending on your system this could Illustrate the Torque power relation**

For more in depth knowledge of start-up calculations and electromotor start up time aspects the reader is referred to Garg and Tomar, J Electr (2015) and the Technical note from ABB “Starting methods for AC motors

But based on the above and variation and rapid spin up times the dynamic power demand for the thrusters could be quite high and up to max power if the spin up times are rapid. i.e. the power could be high from the start and not follow the figure above.

### 3.7.2 Example illustrating the Inertia, shaft speed and torque relations



**Figure 3-19, Example of Typical side thruster with inertias indicated**

From the test carried out on board one of the test vessels found in the appendix, we find that the thruster require about  $100 \text{ kW}$  at zero pitch and  $600 \text{ kW}$  at full pitch. Ref. results from tests found in the appendix.

If we are using a simplified starting time calculation method found for instance in the research article by Garg and Tomar, J Electr Electron Syst (2015) and calculate the minimum spin up time with the assumption that you could not overload the thruster mechanically by more than 25%. ( $750 \text{ kW} / 4005 \text{ Nm}$ ) You will end up with an acceleration time of about 1,5 seconds if the pitch is at zero and 2,5 seconds if you have a fixed propeller.

If you will not allow for any overloading of the thruster and have a maximum moment/power of  $3204 \text{ Nm} / 600 \text{ kW}$ , the resulting spin up time will be about 4-4,5 seconds for this thruster if started with full pitch and about 2 seconds with zero pitch.

If the spin up times of a thruster of this size is above the above listed times it seems not to be mechanically overloaded.

The thruster on board the vessel found in Appendix was a thruster running with constant rpm and was started by a star delta starter with unknown starting but about 2-3 spin up time seems reasonable. It was further found to be able to change the pitch from 0% to 100% in about 5 seconds.

If this thruster was a fixed pitch thruster variation its thrust by change of speed and direction the maximum acceleration time of cause depends on how high acceleration torque the thruster could manage, but as the simple calculations indicate it could not be much faster than about 4 seconds. The example thruster is a reasonable small side thruster about 1,5 m diameter of the propeller. More accurate calculations and for several thrust sizes is proposed to find normal times. These lower ramping times should of cause be specified by the thruster manufacturer, and properly considered in the thrusters control system.

The faster you spin up your thrower the higher dynamic power you will need, this is not properly reflected in my load cases scenarios later in this assignment and more considerations should be paid to this developing typical power curves.

### **3.8 Maximum thrust response seen from Main Power Generation System perspective**

Traditionally one main engine was selected according to the main propeller and it was directly driving the main propeller, or it could be arranged with a main reduction gear and possible a power take out shaft driving a shaft generator. The main engine load was controlled by variation of speed and possible pitch of the propeller.

If you have a main reduction gear with a clutch in system, the time the clutch use to fully engage was important to control to avoid to high torsional loads. The clutch in was perform at near idling speed of the engine and then the engine speed and pitch was normally controlled and set according to the dynamic capability of the engine taking into consideration maintenance related issues and considerations for the engine and its system. Auxiliary generators was normally supplying the Main Switch Board (MSB) for hotel and auxiliary system loads.

This thesis will focus on vessels and arrangement with diesel/gas electric power system.

The same dynamic challenges applies also for these systems, but are not as closed linked and easy understood as for the traditional directly driven propeller set up.

#### **3.8.1 Diesel electric systems**

A popularly called diesel electric system is a set up with normally several diesel generators supplying power to your main switchboard (MSB) and the various consumers as thrusts are supplied from the switch board.

The MSB is normally divided into at least two sections by a bus-tiebreakers, (There are several configurations and philosophies related to sectioning of the MSB). The main reason for this is to build in redundancy so that a fault in one section doesn't have consequences for the neighbour section.

For critical operations it has been normal to operate with open bus-tiebreakers i.e. having the main switchboard spitted in sections. The sections have typically been arranged with one bow thruster and one aft thruster at each side of the breaker as illustrated below.



And the idea is that you in a DP operation should be able to maintain your position if you lose one side or section of your MSB. i.e. you will have to run with machinery only partly loaded at both side of the breaker to be able to take tackle the load change from building up of thrust of the remaining thrusters to keep your position.

Typical set up for modern diesel electric vessel today could be something similar to the below

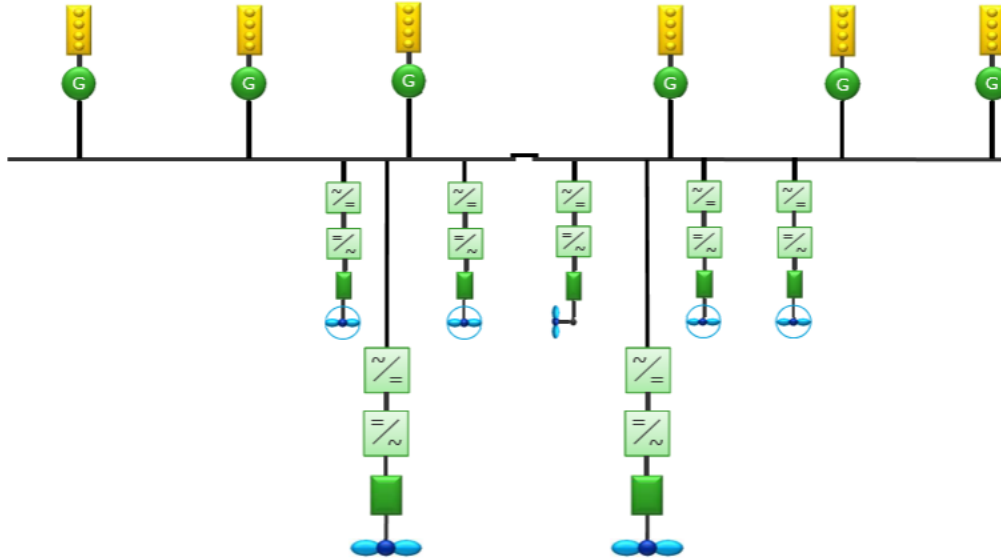

**Figure 3-20, Typical Diesel electric setup**

There are also as described below now control system that enables you to run in DP and in modes with a closed bus tie, The control are then design to be able to isolate a fault before the fault causes a black out, normally by opening up of breakers.

### 3.8.1 New technology, opportunity and challenges

The traditional way the DP vessels have been operated is as mentioned with open bus tie bars and engines running at part loads at each section this has resulted in a spinning reserve (inertia + high dynamic capabilities). But have also resulted in challenges related to maintenance, high fuel consumption and environmental footprint.

The industry have therefore with the incentives as reduced fuel consumption and environmental footprint as well as reduced running hours and maintenance of generator sets, created systems with high degree of integration of various control systems.

The result is flexible and cost effective and more environmental friendly vessels, but it have also its challenges related to higher degree of complexity and need for operational awareness and understanding.

We must also ensure that the dynamic capabilities with less running machinery are understood and handled. This will be one of the main topic for the remaining part of this thesis.

### 3.8.2 Diesel electrical systems and different modes

From fig. 4.11 we find that this vessel have 6 generator sets that could supply the MSB, and the vessel have 2 main propulsion propellers and a total of five manoeuvring thrusters.

The reasoning and considerations behind such a set up could be several. Redundancy and reliability as well as flexibility, fuel and maintenance costs are of cause important.

From a design point of view, you normally break the operation of the vessel down into an operation profile and analyse time spent in the various operation profile modes.

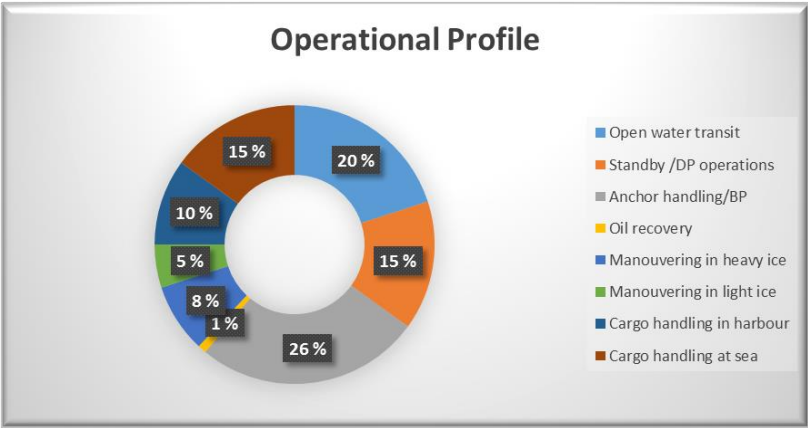
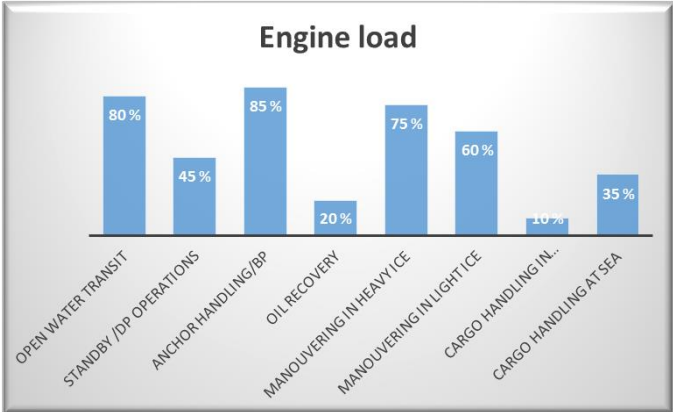

**Figure 3-21, Operation profile example for a given vessel**

Modes could typically be as listed in the above figure or simpler like: Harbour, Transit, Manoeuvring, Standby, DP mode 1 (closed bus-tie) DP mode 2 (open bus-tie) and other relevant operation modes.

**3.8.2.1 Electric Load Calculation / Static Load Analyse**

The next step is to analyse the static power needs for the various modes or operation profiles. In this process you will normally set up an electric load calculation for the vessels different operation modes and possible use load factors and diversity factors between the various consumers.



**Figure 3-22, The various operation modes have various power need profiles**

These static analyses are also require submitted to and approved by the vessels class society. They are normally made in some kind of tabular form showing engines running in the various modes and the power consumption by the various consumers.

**3.8.2.2 Defining main generator set up and “running modes” for the various operations.**

The above are simple tools to help you define, analyse and select your static configuration.

The Load analyse could be used to define minimum MSB running modes open closed bus tie breakers as well as minimum numbers of generators running in the various sections of the MSB.

For some modes automatic load dependant start of generator sets could be allowed and for other modes minimum number of running generators might be defined.

To define the main generator configuration is essential and a complex exercise and will not be the focus in this thesis, more guidance is found in other work. This thesis will focus on the dynamic capabilities of the main machinery systems and combinations.

### **3.8.3 Power management systems**

All diesel electric vessels is requested to have a power management system (PMS), in this system you will normally set the operation mode as well as defining minimum numbers of generators connected to the MSB as well as starting sequence of additional generators sets.

The PMS system will try to manage, reserve, and automatic start up additional power sources based on increased power demand from various control systems by limit the power to various consumers or avoids them from being started up until sufficient power is available.

If the power load is increased too fast for the generators to respond, or the load is higher than the available power, the result is under-frequency on the power network. If the network frequency becomes too low, the generators will be disconnected, with a blackout as result. This is one of the worst scenarios on board a DP vessel.

In severe weather conditions and during manoeuvring, the dynamic loading of the thrusters may result in unpredictable power variations. In order to meet dynamic power demand the system should ensure to have more dynamic power available. This could be sorted by having advanced flywheel or battery installations installed to take care of these dynamic requirements. As far as I have found such systems is not incorporated in the PMS systems used today.

Hence, predictable power consumption is of major concern for the power management system in order to avoid blackouts, improve the performance and stability of the power generation and distribution network, and minimize fuel consumption and wear and tear (Lauvdal and Ådnanes, 2000; May, 2003; Sørensen and Ådnanes, 2005; Radan et al., 2005).

There could be several level of black out prevention systems incorporated in the PMS. The most common is that you have a power available measuring system the measures the static power available at your MSB and compare this with the consumed power. This signal is used to limit and block heavy consumers to use more power until more generators are started and connected to the MSB.

The PMS is sending this signal to the thrust control system and by this controlling and limiting the thrusters frequency drives and pitch system.

In case of tripping of generators this signal is also used to reduce the power used by thrusters. Depending of your configuration this might not be sufficiently quick as there are several controllers that should communicate. A secondary black out prevention system are therefore normally incorporated it the thrusters drives. This is monitoring the frequency and if it detect a drop of more than typically 3 Hz it will automatically reduce the drive power and prevent a black out.

This could typically be needed if you are running with several generators in parallel close to full load and one of the generators trips for some reason. The remaining generators dos not

have the capacity to manage the running load and you will have a overloading and a black out if not the load is rapidly reduced.

As described above the traditional way of running vessels in DP is to split the MSB and have sufficient generators running at each section of the split to take the gradually build-up of thrust needed if the other side trips. i.e. they are running at 50% or below and will be loaded to 100% in the event of a failure.

The desire to operate the vessel with less fuel and maintenance cost and have as environmental friendly footprint as possible, result in that the vessels are operated with as little running generator capacity (highly loaded generators) connected to the MSB as possible. In the event of partial tripping or increased power demand the control system need to handle this by adjusting loads and automatic connect more generator power to the MSB.

The requirements for complete understanding of the power generation and consumption systems is therefore essential and will have to be built into the control systems.

The interaction between the various control systems as (power management and energy management systems) PMS/EMS and the Thruster/DP control system result in that you could experience different power and thrust response for your system. And the thrust response is dependant of the number of generators on line and the time to start up new generators.

To ensure that you have control of the dynamic power requirements when defining the operation modes is therefore essential to understand the thrust response you could expect in the various modes.

These relations and effects for thrust build up times seem not to always be taken into considerations when performing dynamic simulations in various tools. As mention above the relations are not as easy to understand and could vary for several modes, we might risk to simplify our models and not understand the complete dynamics of the vessel if we don't consider this in a proper way. In my view we therefore need to establish a simple early design system that could make us aware of these relations and help us select better modes in early design and possible help us control the soundness of modern models.

### **3.8.4 Stability of main switchboard, frequency, volt etc.**

As described above there are several factors that will influence on your systems stability.

The class rules as for instance DNV GL rules Pt.4 Ch.2 Sec.5 have several requirements for diesel electric propulsion systems and for their prime movers driving electrical generators.

In general they should be designed to handle two steps load 0-50% and 50-100% but the rules opens up for mulita step loading with some given conditions in Pt.4 Ch.2 Sec.5 paragraph 1.6. Pt.4 Ch.8 has in addition several requirements for transient load variations and times for reaching steady state for Voltage and frequency.

The rules are also opening up for more gradually loading of generators and the MSB if you have a control system that ensures the stability of the system in case of rapid dynamic power variations.

Several vessels are today built and tested with 3 steps of 33% of the max Load for the generators. This implies that you for one generator have 3 instant steps and you should have a steady state after 5 seconds with some allowance frequency/volt and Hz variations. For these generator sets they are capable of increasing their load from 0-100% and have a stable system in about 15-20 seconds.

For several of the engine manufacturers this is stated to be an emergency mode test and they don't recommend this to be the normal loading rate of their engines.

### 3.8.5 Power Generator and Electric consumers relationship

If we simplify the system we could link the consumer power requirements to the generator power more or less directly with some kind of system damping factor.

A generator have approximately the same Torque curve as the electric motor previously described and have a catachrestic depending on type, size and number of generators on line.

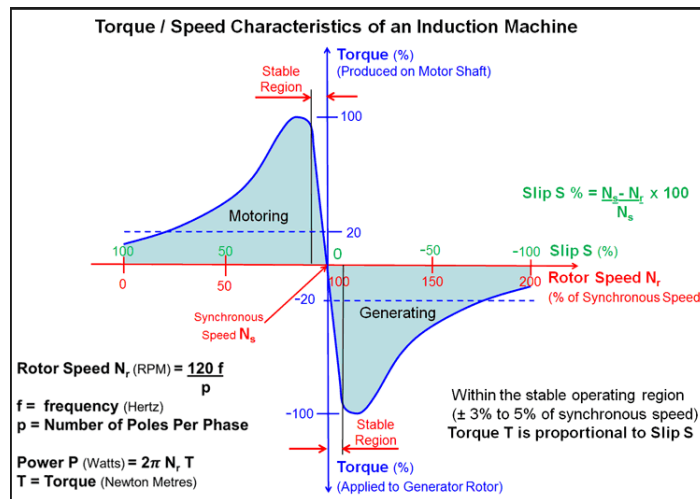

Figure 3-23, Illustration of EL motor "Motoring" / "Generating" relation

Depending of the size of the thruster and how many thrusters as well as other heavy consumers that demands power at the same time, the generators and diesel engines driving these will have to cope with power transients.

The engines driving the generators could have different capabilities when it comes to this, but as mentioned above the class rules have some basic requirements when it comes to load steps and stability of the system.

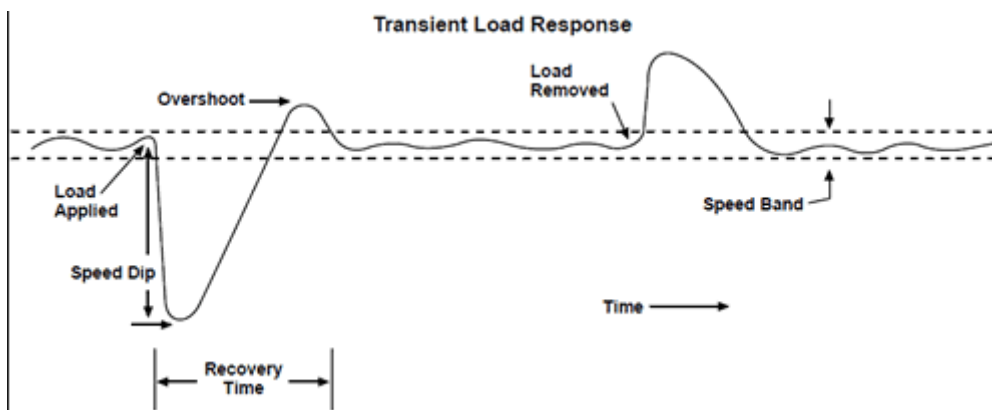

Figure 3-24, Typical diagram for a system with a changed load

Typically a change of power demand will directly result in changed load/torque for the generators and this will result in a speed variation until the engines control and governor system adjust the fuel (& air) flow to compensate. As mentioned above the class rules indicates limits for these variations and load changes.

### 3.8.6 Diesel/Gas Engines:

Both Smogeli (2006) and Pivano (2008) touch upon the dynamics of diesel engines and point out it is quite complex and, generally, it is slower than the dynamics of electric motors. Pivano (2008) in their work refers to Makartchouk (2002) and Xiros(2002).

It is in several theses it is stated that a diesel engine could be modelled in a similar way as the electric motor. And (Blanke, 1994) states that the diesel engine power is proportional to the fuel flow.

For control purposes, simple models are usually employed. For example, according to Andersen (1974) and Blanke (1981), the motor dynamics can be approximated by a transfer function that accounts for the gradual build up of cylinder pressure and the discrete nature of cylinder firings. In their work they have made an engine transfer function  $Q_m$  given by:

$$Q_m(s) = e^{-s\tau_m} \frac{K_y}{1 + sT_m} Y(s), \quad T_m \approx \frac{0.9}{2\pi n_m}, \quad \tau_m \approx \frac{1}{2n_m N}.$$

$K_y$  is the motor torque constant,  $Y$  is the fuel index,  $T_m$  is the time constant and  $\tau_m$  is the time delay,  $n_m$  is the rotating speed and  $N$  is the number of cylinders.

Giving us that the desired motor torque could be written like:  $Q_{m_d}(t) = K_y y(t)$ .

Pivano (2008) points out that there could be found other models.

The above does not take into consideration the challenges the engine manufactures have related to rapid heat changes, and the challenges related to build up and down turbo pressure etc. during dynamic operation of the engines.

My argument is that these models possible are a little simplified and that you for a modern highly turbocharged engine must control the loading rate and temperatures etc. more carefully to avoid damages and problems.

Your power generation model need also to be modelled with is applicable modes, number of generators on line and start-up/connection times etc.

#### 3.8.6.1 Loading Capacity and loading rates

Different engine makers have different approaches to their loading rates; most of them have a curve for “emergency” loading rate for generators to fulfil class rules with tree load steps of 33% and steady state within about 5 seconds, and a different loading rate for normal operations.

Asking dealers and searching for documentations related to this seems too difficult for some engine manufacturers, some data and test results are handed over indicating that their engines could manage to be loaded from 0-100% in about 15 to 20 s for engines up to about 1800 kW

Wärtsilä for instance is for their Auxpac series stating loading rates for normal and unexpected situations in their Product Guide and are quite open in their communications and advice around this topic.

Quote from their product guide:

“The loading rate of a highly turbocharged diesel engine must be controlled, because the turbocharger needs time to accelerate before it can deliver the required amount of air. Class rules regarding load acceptance capability stipulate what the generating set must be capable of

in an unexpected situation, but in normal operation the loading rate should be slower, about 60 seconds from zero to full load for W20 and W26 based auxpacs and 80 seconds for W32 based auxpacs. The generating set can be loaded immediately after start, provided that the engine is pre-heated to a HT-water temperature of 60...70°C.”

In their product guide for their diesel generator pack Auxpac series they are also defining maximum instant load steps and how their engines preferably should be loaded.

Quote:

“The automation system and the operation of the plant must prevent excessive load steps. The fastest and smoothest loading from 0% to 100% is achieved with gradual load increase in small increments. The maximum instant load application is 33% MCR. However, if the engine is not equipped with Variable Inlet valve Closure (VIC), the maximum instant load application is limited to 25% MCR for the following generating sets: 645W4L20 (900 rpm/60 Hz), 975W6L20 (900 rpm/60 Hz), 1000W6L20 (1000 rpm/50 Hz), 1350W8L20 (1000 rpm/50 Hz), 1550W9L20 (1000 rpm/50 Hz).”

As mentioned above the class rules as for instance DNV GL rules Pt.4 Ch.2 Sec.5 have several requirements for diesel electric propulsion systems and for their prime movers driving electrical generators.

In general they should be designed to handle two steps load 0-50% and 50-100% but the rules opens up for mulita step loading with some given conditions in Pt.4 Ch.2 Sec.5 paragraph 1.6.

The rules have included a Guiding note indicating Typically limiting curves for diesel engines and examples of maximum load acceptance of large bore gas engines with port injection depending on base load.

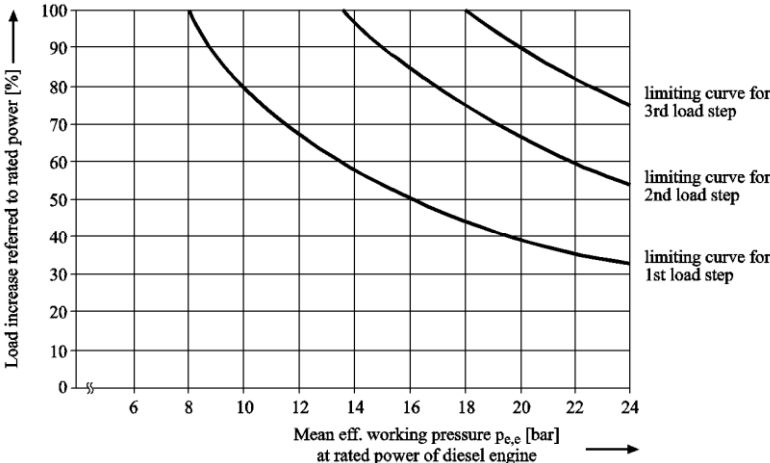

**Figure 3-25, Example of limiting curves for loading 4-stroke diesel engines step by step from no load to rated power as function of the brake mean effective pressure given in the DNV GL rules.**

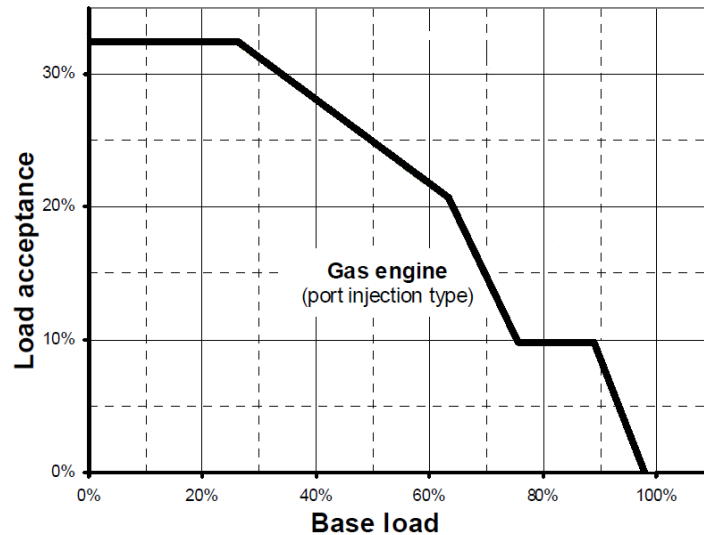

**Figure 3-26, Example of maximum load acceptance of a large bore gas engine with port injection depending on base load, Ref. DNV GL rules.**

Pt.4 Ch.8 has in addition several requirements for transient load variations and times for reaching steady state for Voltage and frequency.

Normally the generator sets are accepted tested in 3 steps of 33% of the max Load implying that you for one generator have 3 steps allowing for a steady state after 5 seconds and you allow for some frequency variations. So for a normal diesel engine this result in a recovery time for about 15-20 seconds.

For a GAS engine used as a gen set you will need to ensure that you have an electrical control system that is designed accordingly possible for a dual fuel engine by switching to diesel for such demanding load step operations.

If we once again look at Wärtsilä and their dual fuel engine 20DF, we wind that in their product guide have the following information for Constant speed application.

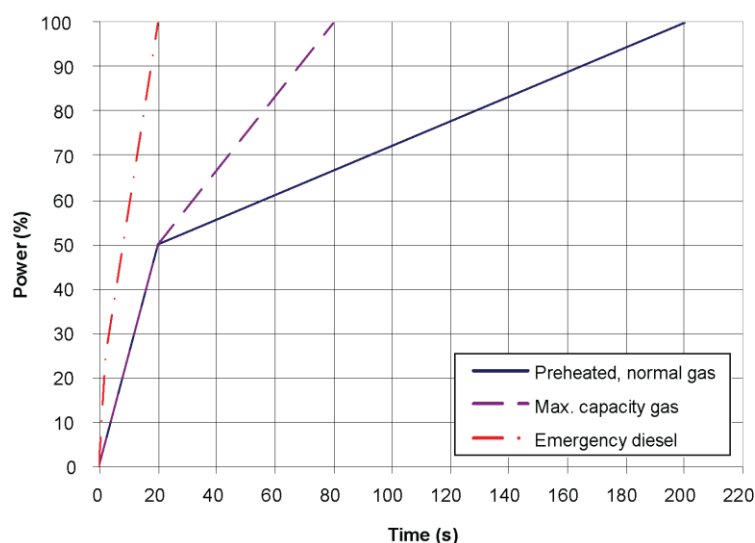

**Figure 3-27, Increasing load successively from 0 to 100% MCR**

Ref.: <http://cdn.wartsila.com/docs/default-source/product-files/engines/df-engine/product-guide-o-e-w20df.pdf?sfvrsn=4>



Wärtsilä is also pointing out that the propulsion control and the power management system must not permit faster load reduction than 20 s from 100% to 0% without automatic transfer to diesel first. This could be challenging with suddenly tripping of bus tie breakers due to safety functions and trips and should be investigated.

Wärtsilä is also stating that in electric propulsion applications loading ramps are implemented both in the propulsion control and in the power management system, or in the engine speed control in case isochronous load sharing is applied. When the load sharing is based on speed droop, it must be taken into account that the load increase rate of a recently connected generator is the sum of the load transfer performed by the power management system and the load increase performed by the propulsion control.

This is an important note when you have automatic load dependent connection of a new generator it will be loaded with the shared load and possibly with an increased load from various consumers and the control system must cope with this as well.

In addition to the above the engine manufacturer has a variable load step capability for variable initial load level for their gas engines. And are stating that the electrical system must be designed so that for instance tripping of breakers should not result in load steps above their curve.

How sudden the load step could be performed is not clearly defined, but it is obvious that this has implications for the control system. If we take an example of two generators in parallel sharing the load for a propeller system and you lose one of these you will have a load step from 50% to 100% for the remaining engine. Depending on your control system's ability to reduce pitch, Torque/RPM or actually tripping the propeller you will, to my understanding, exceed this load step in the event of a failure. Possibly you could switch over to diesel and have a stiffer system. I will later argue that you in normal operations with variable load for thrusters also could end up in conflict with the below curve for max load steps.

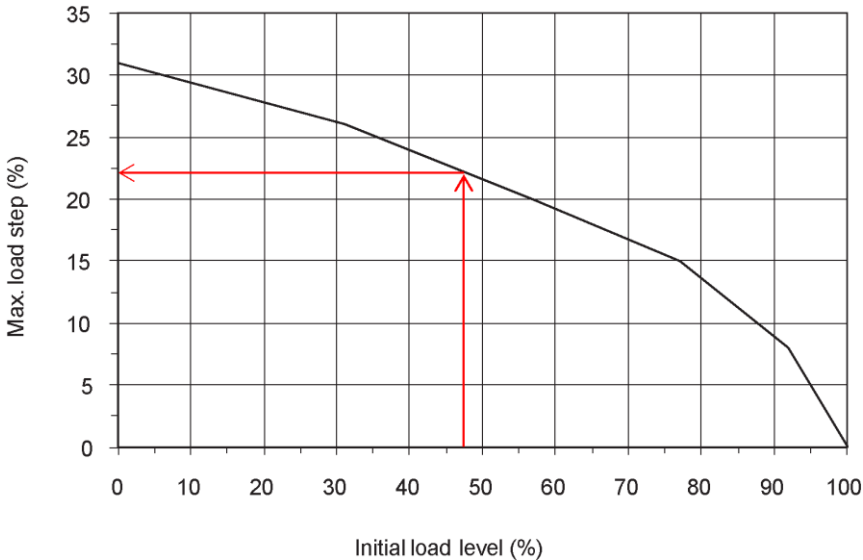

When performing the electric load analysis for the vessel in various operating conditions, evaluate possible scenarios that cause sudden load changes and check against the engine capacity in gas mode as shown in the diagram.

**Figure 3-28, Wärtsilä 20DF engine Maximum instant load steps in % of MCR in GAS mode**

For GAS mode Wärtsilä state the following for their 20DF engine:

- Maximum step-wise load increases according to figure
- Steady-state frequency band  $\leq 1.5$  %
- Maximum speed drop 10 %
- Recovery time  $\leq 10$  s
- Time between load steps of maximum size  $\geq 15$  s
- Maximum step-wise load reductions: 100-75-45-0%

For Diesel mode for the same engine Wärtsilä is stating the following:

- Maximum step-wise load increase 33% of MCR
- Steady-state frequency band  $\leq 1.0$  %
- Maximum speed drop 10 %
- Recovery time  $\leq 5$  s
- Time between load steps of maximum size  $\geq 8$  s

The quickest their engine could be loaded in Diesel mode is 3x33% with 8 seconds apart resulting in 24 s from 0-100% possible a little quicker with gradually increased load ending up according to their read line at 20 s for a load increase from 0-100% in “emergency” diesel mode and 20 s for 0-50% in gas mode and 60-180s from 50-100% in gas mode.

My understanding of the above is that we for most generator sets used today are able to change the load from 0-100% in about 15-20 seconds, for some of the smaller ones you could manage even higher load rates down to 0-100% at about 10 seconds but it seems like this is not recommended load change for normal manoeuvring of the vessel.

With today’s multi engine installations, automatic start up and load sharing and taking into considerations the above referred to guidelines from the engine manufacturers indicating limited ability to take instant load steps in “emergency”/class requirement mode and giving advice for less steep and smooth loading of their engines from 0-100% in 60-80s diesel (and up to 200 seconds for Gas engines)

We could also have control systems that take into considerations the various modes and number of engines that are connected to the MSB and have a variable thrust response depending on a power change rate kW/s available in the different modes.

What kind of modes should be allowed to use the emergency/class capacity and what should be the more normal modes ensuring good maintenance costs etc. This will end up in a complex control system if we should take all of this into consideration.

The question is for our propeller system with quite rapid load changes in manoeuvring and DP operations how will this play out. The Thruster response needs to be adjusted and tuned to the main machinery system for the vessel.

Other engine manufactures have submitted test results showing that their engines could be loaded faster, but i have not found a good guide related to their recommendations.

Below is indication of 0-33%-66%-100%-0% load steps for a Caterpillar C280-8 ECM engine.

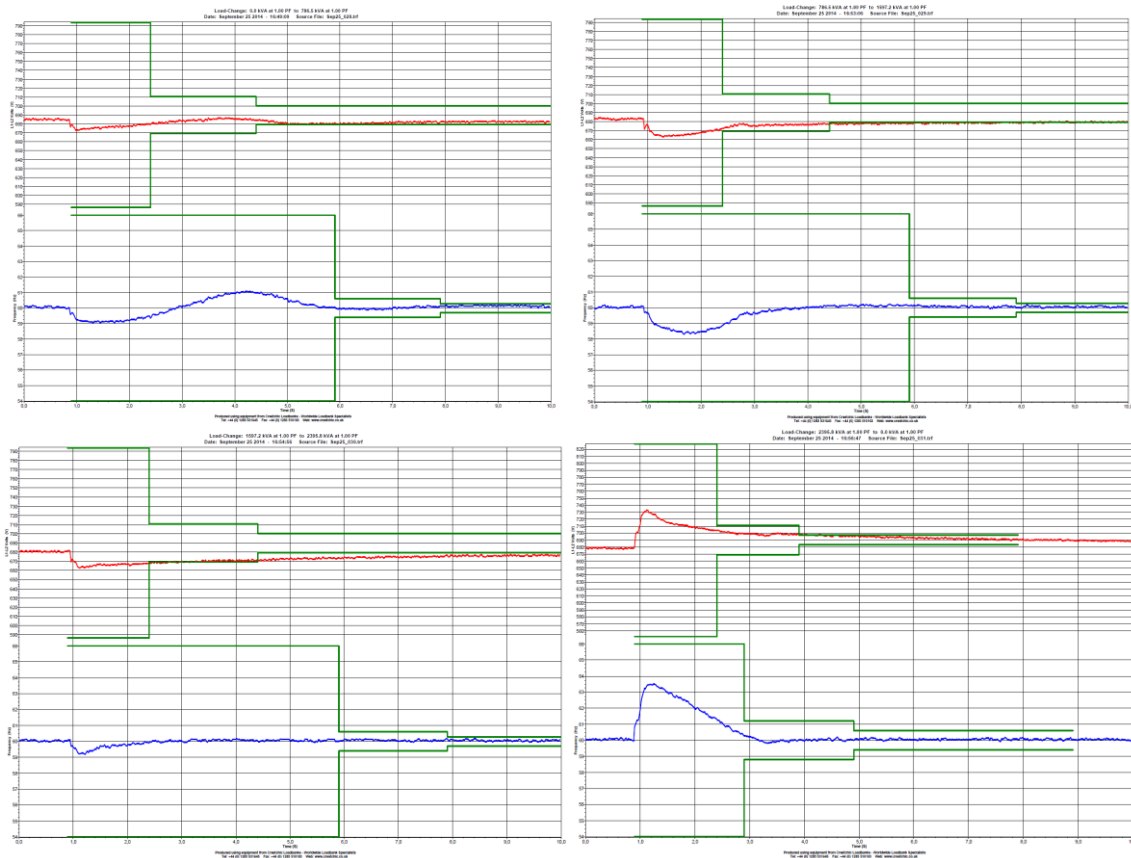

Figure 3-29, Load step testing of diesel engine



Figure 3-30, Sequent load steps in a row to try to illustrate engine capability

The engine have been load up in 3 steps showing volts and frequency changes, these are then taken into a spreadsheet where the next load step is applied at more or less steady state of the engine indicating that this engine could in extreme conditions have a steady state after increasing the load from 0-100% in about 10 seconds, ref. below sketch. But the engines manufacturers' advice related to such rapid load increase is not clear to me. This is just included as an example that diesel engines will in some cases is able to handle rapid load changes but it might not be advisable to load the engines in this way in normal operation.

Similar data could also be found by other engine makers and as far as I have found the lower loading ramping times advised for a diesel engine is 15-20 seconds. And this should possible not be the normal ramping time, but more to be understood that they could be ramped up at this time in emergency situations.

We know also that we have smaller emergency engines that could handle 0-100% load and have steady state in about 5 seconds so it is of cause possible to make engines with higher inertia etc. enabling them to handle this, but we should also understand the heat transfer and maintenance challenges involved.

**3.8.7 Stored energy source to handle short term load variations as well as replacing running machinery**

As indicated above your diesel or gas engines could have dynamic limitations related to rapid power variations.

By use of some kind of accumulated energy source such as battery's or a big fly wheels or similar you could build system that have a much higher dynamic power capability.

With such systems you could manage faster response times with less running machinery.

This will be further discussed in Part 2.

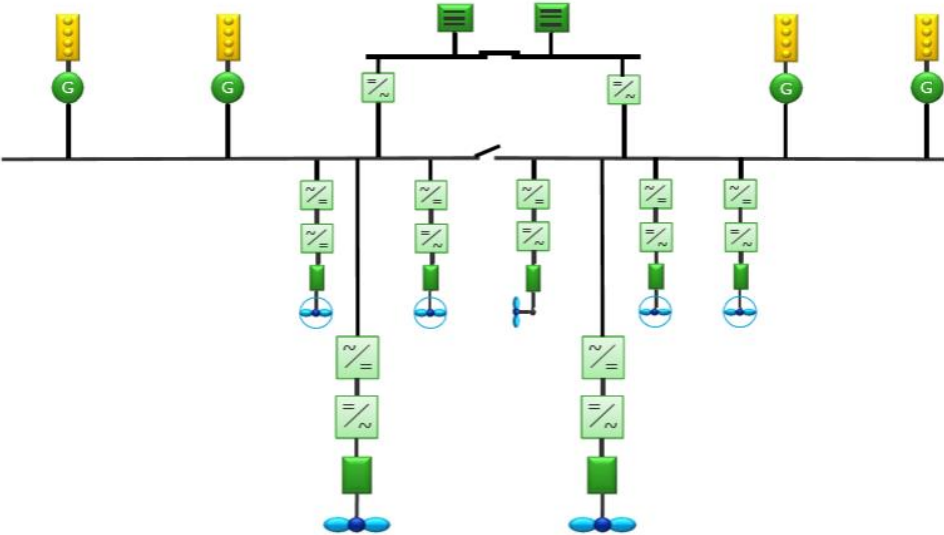

**Figure 3-31, Main Switchboard illustration with accumulated energy source**

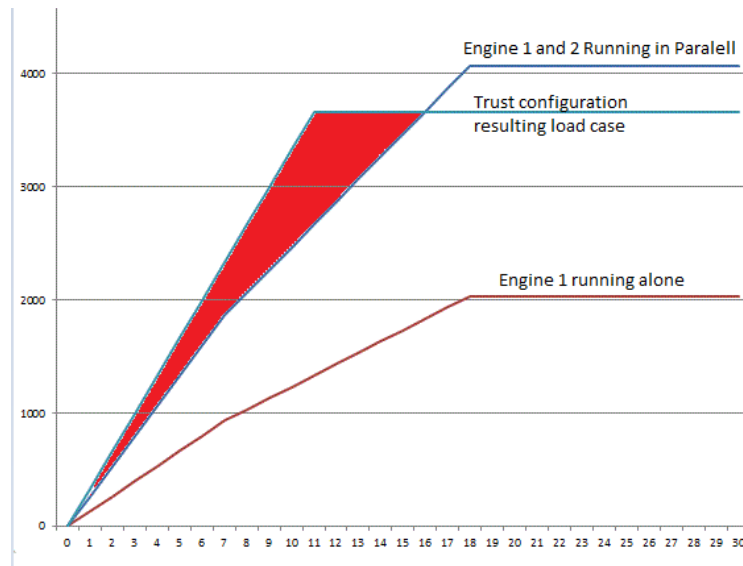

**Figure 3-32, Illustration of one side of the MSB above, two generators running in parallel and a resulting dynamic load request above their recommended load rates. This red area could be handled by a battery or flywheel installation.**

The resulting dynamic load and change capacity will be described below.

Finstad 2016, might be consulted for peak-shaving control and dimensioning of energy storage units

### 3.8.8 Resulting system dynamic load change capacity

Based on the above knowledge about the engines and generators we realise that we should ensure that they are loaded according to the manufacturer’s recommendations in normal operations.

We know that depending on the amount of generators we have running in parallel the static load capability increases with the generator capacity.

If we also model the diesel engines dynamic load recommendations according to the makers recommendations we could create the below graph, indicating that the engines could be fully loaded in a given time and the number of engines in parallel gives us the resulting dynamic capability as well.

The below figure indicates approximately the slowest response rate acceptable according to class rules. (As earlier mentioned this is in many cases higher dynamic loading rates than recommended for normal operations by some engine manufacturers) The figure shows that depending on how many generators you are running in parallel you could find information of how fast you might allocate power to thrusters and consumers in general etc.

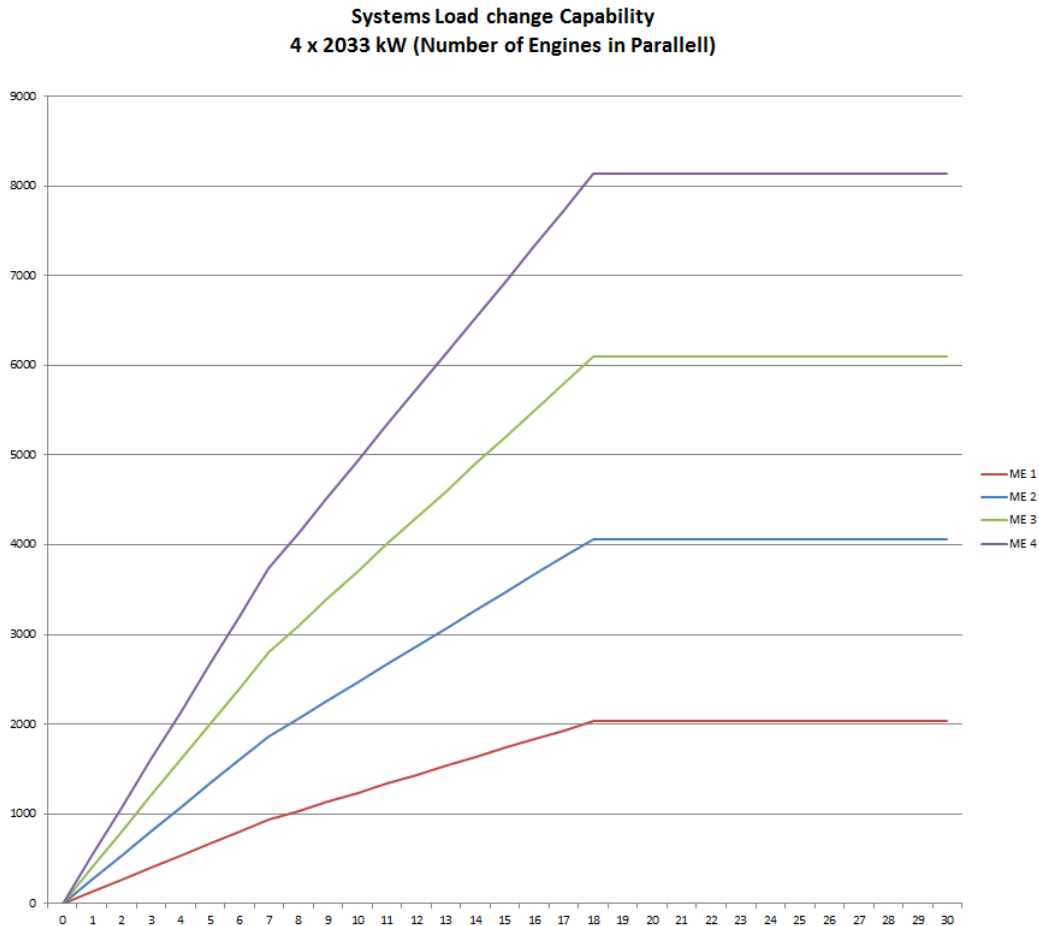

**Figure 3-33, Example of diesel electric power/time capability, engines running in parallel**

As mentioned above the PMS system might also automatically start and stop generators depending on system load settings.

The start signal could for some systems are the limits for the highest consumer that is not running, or it could be at a certain % of load. i.e. if the load of the MSB is above 75% of the generator capacity it will start and connect a new generator set.

The time from the start signal is given until the generator is connected to the MSB and sharing the load could vary (Based on my experience this could typically be from down to possible 10 and up to about 40 seconds).

The figure below indicate a extremely fast system with a connection time, but a load dependant start of generators based on the above will have effect for the dynamic load capability your system will be able to handle.

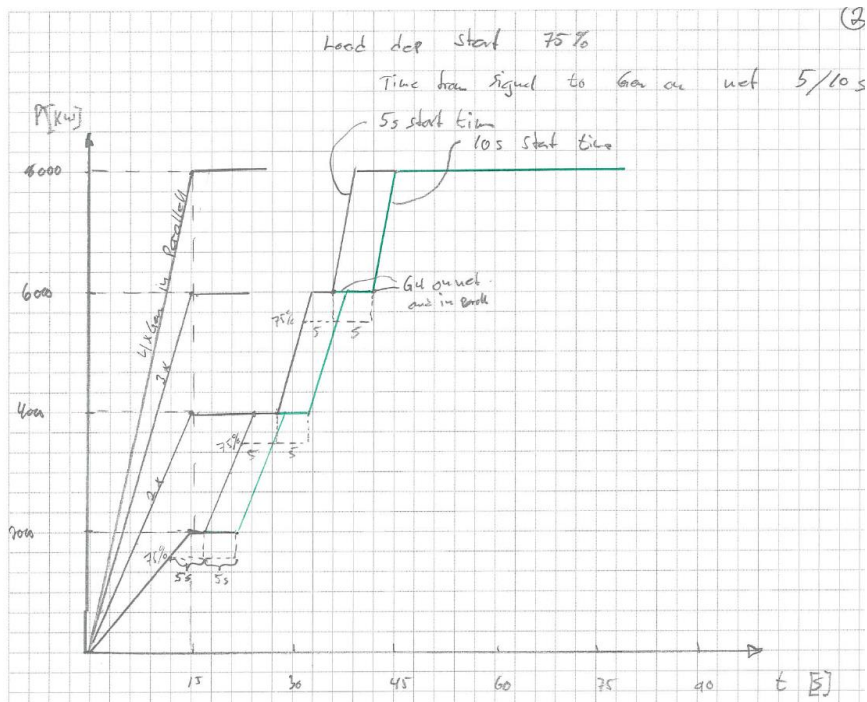

**Figure 3-34, Example of diesel electric power/time capability depending on load dependent starts and numbers of generators connected in parallel**

### 3.8.1 Maximum dynamic load from thrusters and heavy consumers

The request for thruster effect is given by the master by moving his control levers at the bridge, or by giving an input to the DP system requesting a move (joystick operation or by entering new coordinates) or it could be a request from the DP system for the vessel to keep its position.

The signal is given to the thrust control system and depending on the tuned loading rate it will start changing the thruster's effect.

As we have studied above thrust changes for different thrusters types result in different load curves (fixed rpm/variable rpm/variable pitch) this is due to several factors and depending on how fast you change speed and pitch of your thruster etc.

If we also simplify this and state that the load curve is linear and changes from 0 to 100% based on the request signal in a given time (the time need to be well above the torque inertia spin up time discussed above, and we from above know that for thrusters running with constant speed we have effect requirement also at 0%) This is possible not a correct representative figure as the real load demand possible would be higher at the initial change request, but this is considered partly taken care of by the systems damping effect.

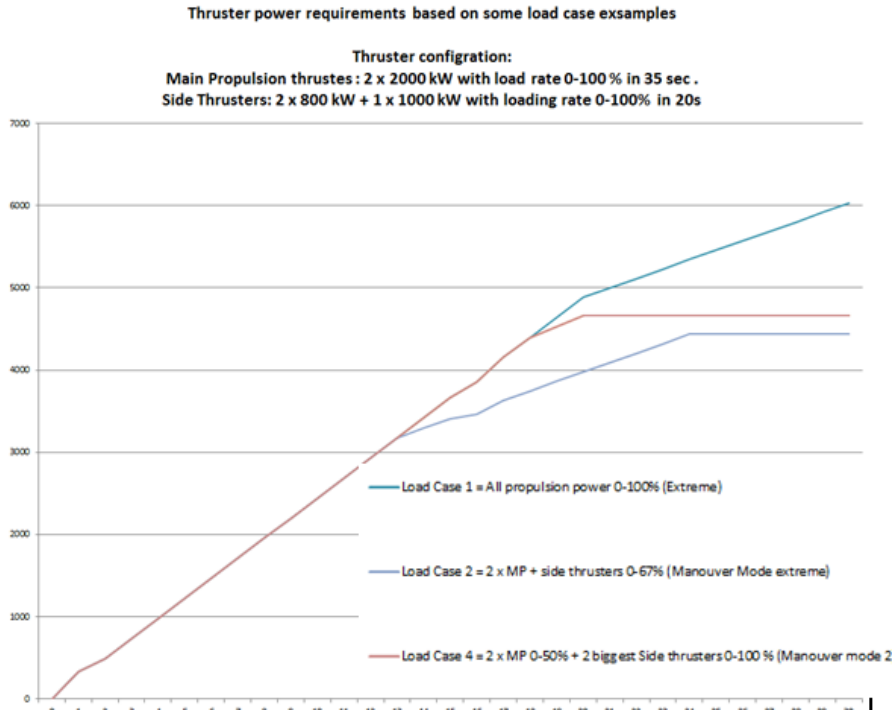

**Figure 3-35, Typical Power demand from Thrusters**

The above figure illustrate the power requirements for some load cases for a given thruster configuration with rather slow response times.

If we take this power request curves and put into the main machinery power generation capability curves. We will be able to see how this will relate to each other

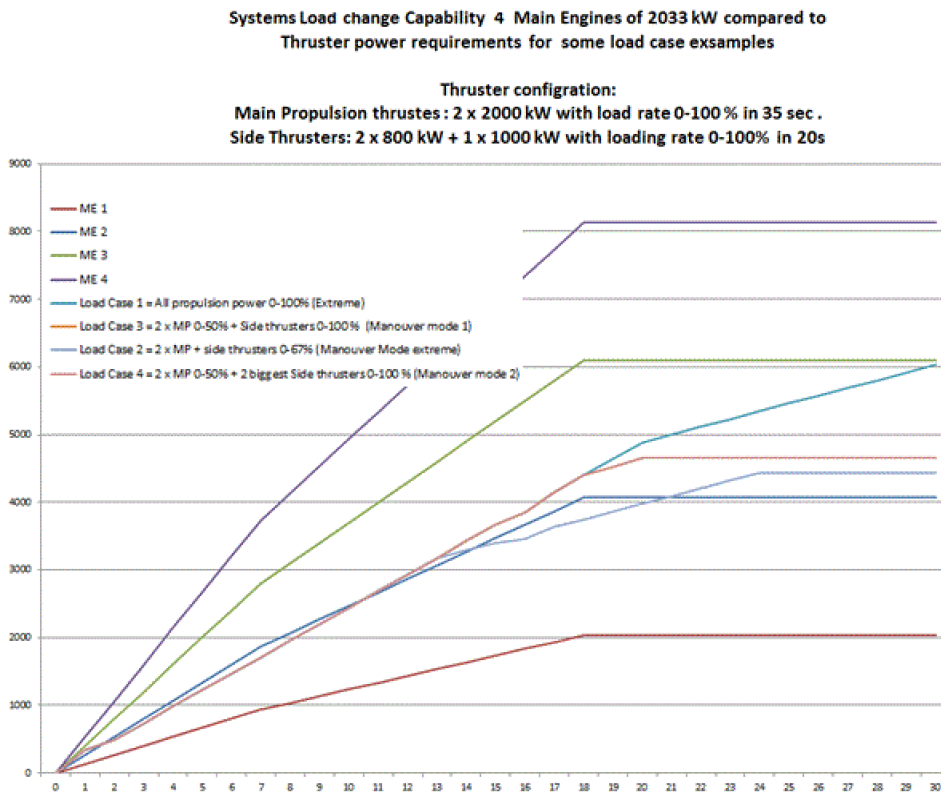

**Figure 3-36, Main Generators in parallel and Typical Power demand from Thrusters**



If the power request to the thrusters is higher than the capability of the machinery configuration you will end up with a dynamic loading of your engine that is higher than the recommendations given. If this curves is the absolutely limits of your engines and you don't have any black out prevention system incorporated a black out might be the result. This illustrates the importance of setting up correct running modes and the importance of the various control systems and their interaction with each other.

If the PMS system send a limiting signal to the DP or Thrust control system the control systems are sometimes not able to priorities thrust to the "right" thrusters, the one with the fastest load increase possible get the resources and other thrusters don't, this is sometime reported by masters as faulting systems as he is be lacking response from other thrusters for instance. This is a different problem, but should be taken into consideration during design of the control system.

If generators are by the PMS system set to automatic Load dependent start they the time it will take for the thrusters to go from 0 to full power will increase, how much the time increase will be depend on the set point for start-up of new generator and the time for the generator to be connected.

But the time to allocate full thrust at several thrusters could easily be 30 to 60 second in some cases with load dependent start of generators.

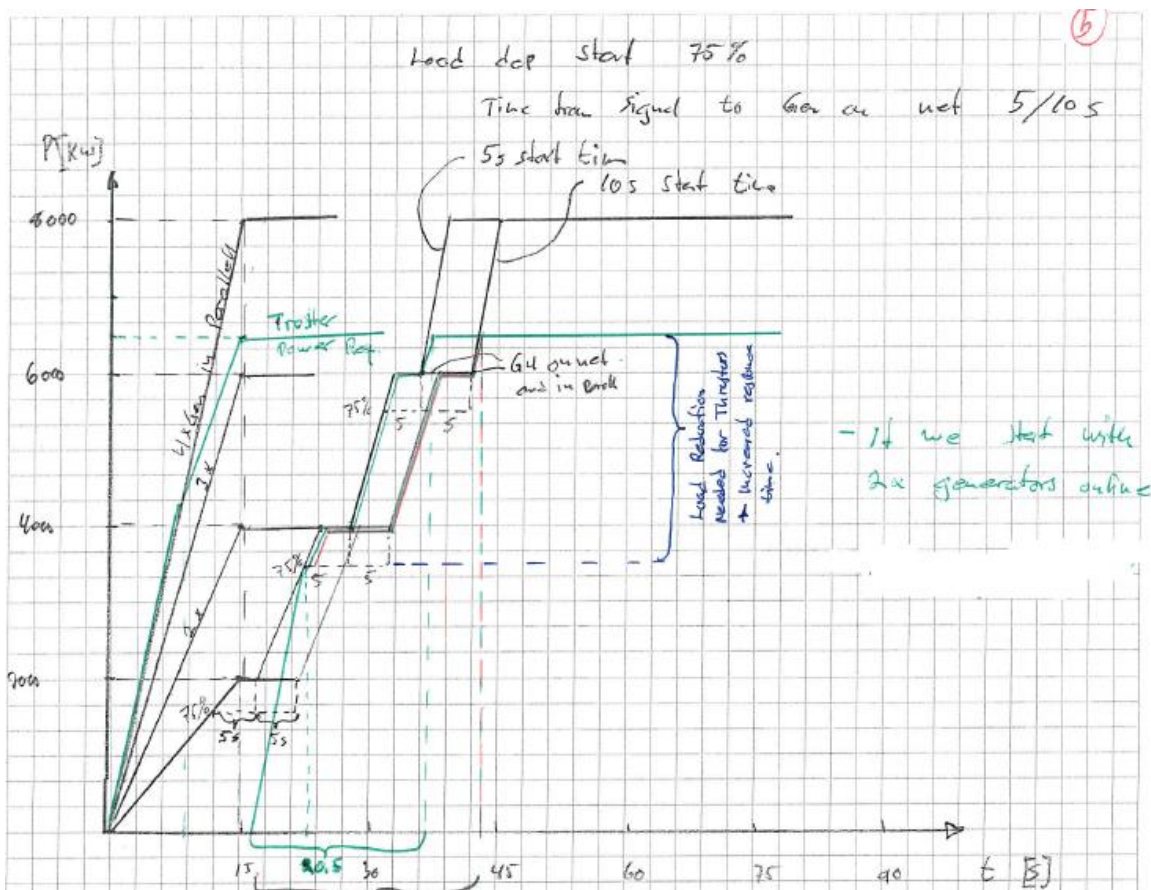

**Figure 3-37, Actual resulting thrust response times variation from 15 to 30-40 s depending on configuration and auto start times**

### 3.8.1 Dynamic load above recommendations from generators, and use of accumulators for dynamic peak shaving

As indicated above you could build system with stored energy to be used for to take higher dynamic loads.

Depending on your configuration and the size of these you could have full ramping times of your thrusters as illustrated in Figure 4.32 above.

Or the dynamic addition is limited and controlled by the PMS based on static power available signals as indicated in the figure below.

Your accumulator could also be sufficient to cover the complete dynamic effect difference.

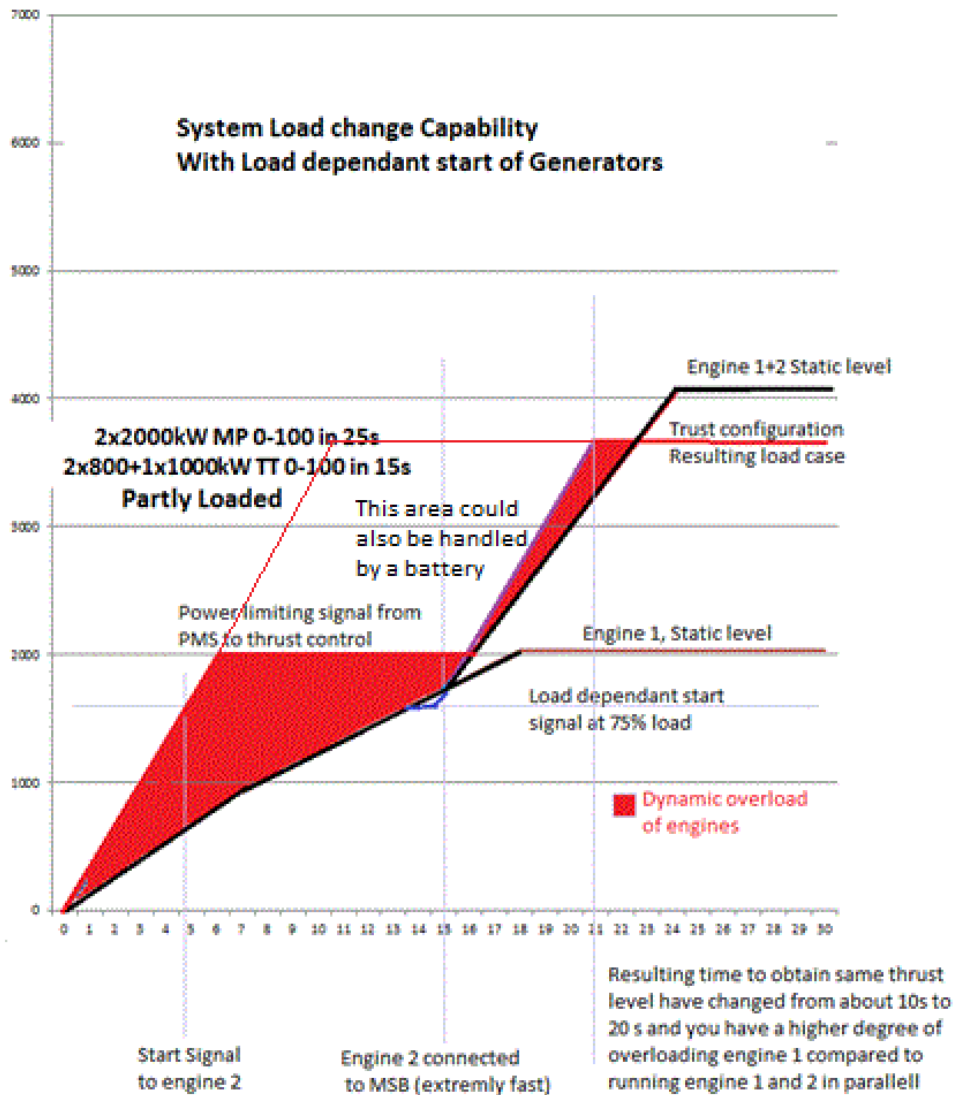

**Figure 3-38, Illustration showing one generator on line and automatic start-up of generator 2 at 75% load. Dynamic load curve from thrusters above engine recommendations. PMS power limiting signal to thrusters resulting in increased ramping time.**

Tor A. Johansen et al (2014) and Finstad (2016), consulted for peak-shaving control and dimensioning of energy storage this has not been the focus in this thesis

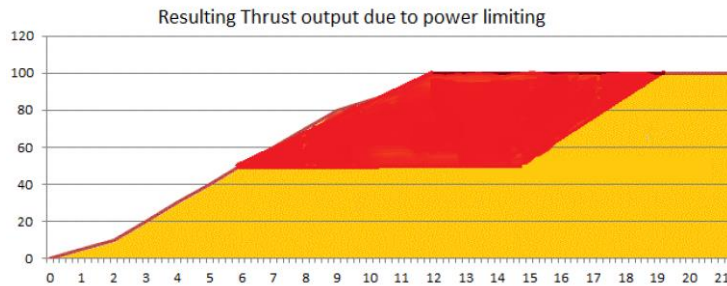

**Figure 3-39, Typically resulting thrust curve with power limitation signal from PMS**

From the above illustrations it is obvious that to determine the vessels thrust response times you could not only study the thruster side. You need to understand the full picture. And depending on the different modes the vessel has it could have various results on its dynamic capabilities.

### ***3.9 Maximum thrust response seen from the vessel's high level Control System perspective.***

As partly discussed above, a modern diesel electric vessel is designed with a high degree of integration between complex software based control systems. These control systems are normally from several different suppliers.

Modern vessels have at least the following control systems with various degrees of interactions:

- Propulsion control system – Controlling Individual or group of propellers pitch and RPM – communicate with frequency converters (Drives) and pitch control modules as well as the steering system for azimuth thrusters.
- Azimuth steering system – input for forbidden angles and thrust reduction etc.
- Dynamic position system – position and movement control of the vessel based on input, sensors and reference systems. Give signals to the propulsion control system and also communicate with the PMS system
- Joystick systems – use sensors for heading and position control but you might control the vessels thrust vector and movement.
- Machinery Automation and alarm system – could also include PMS/EMS – this system will give ready signals for various systems, could block start up and trip generators based on alarms etc.
- Power Management System – Load and frequency control, mode control, auto start stop of generators. Communicate power available signals but has normally not incorporated dynamic power available limitation signals. Black out prevention control.
- Generator sets governor and speed control system – Controlling the engines response to load changes
- Power distribution and conversion control system – switchboards and motor control centres, converters and drives could include black out prevention systems based on several parameters. Directly tripping of breakers, drop of load in drives etc. due to Hz reductions or short-circuit.

It is not uncommon that you have different suppliers for each of the system mentioned above.

### **3.9.1 Thrust control in a total system view**

As all of the above mentioned systems are interlinked with each other, and there are limitations and control settings in several of them might affect the thrust response for a vessel.

An example, If you adjust your manual thrust handle fast from 0 to 100% the actual response of the thruster is given by a setting in the thrust controller. You could move this handle in 2 seconds but you don't get full thrust before after for instance 10 seconds.

The same situation could be that you in your DP systems adjust the "gain" setting (this control how fast it will allocate thrust). But if your DP system is sending signals to the thrust control system it will not be able to operate the thruster faster than what is the limits set in that controller.

And of course if the simultaneous thrust allocation power demand is higher than the control system or the physical capability's for the generators are capable for you will end up in a overloading situation that depending on other built in systems in the worst case scenario could end up in a black out.

### **3.9.2 System capability and stability and maintenance perspective**

After the various systems are tuned and adjusted on board the vessels during sea trial, the various mode configurations are tested. The class societies have requirements for testing the manoeuvring control of the vessels and evaluate the stability for the various systems. These tests have traditionally been crash stop tests and build up and reduction of thrust for the main engines, or main thrusters. For more complex propulsion and thruster configurations these tests need to be carefully evaluated to ensure that you test the worst case for the different modes of operation.

The result of the tests could be that you will have to slow down the response time to avoid Hz or Voltage drops of the MSB.

#### **3.9.2.1 Transients and oscillations, mechanical wear and tear**

The vessels control systems in total need to ensure that all transients are controlled in a way that they are not causing oscillations of various systems. If the total control system is not correctly tuned we could experience "hunting" between generators, and thrusters.

From a vessel position point of view you would like to have full control with how fast you could build up thrust from the various propellers, by this you could tune your system in the best way for the various weather and operation requirements.

For the various system providers, they have some absolute mechanical limitations as well as maintenance and stability issues to consider the limits their individual systems dynamic behaviour.

### **3.9.3 "Human" expectations of response, Thrust generation and vessel movement**

If a command is given from the master and he does not get the response from the system, either it is giving commands in a given controls system for starting of pumps and thrusters, or by operating the thrusters, we expect some kind of reply/response in a given time, this will of

cause vary from system to system...pump signal change to running, vessel movements or vibrations in fore ship etc.. This is not discussed but in the below questions to masters they was asked for expected or desired response times for thrusters.

#### **3.9.4 Various system providers, no clear lines of responsibility. (Several possible solutions but different views and agendas)**

As mentioned above the vessels overall control system is complex and for the shipyard and ship owner it is important that all of the systems interact in the best possible way so that the vessel fulfils its design criteria.

If you for some reason encounter problems, for instance that you total dynamic power requests for a given mode and load case is above the limits that the main generators could handle with the given control settings. This might be handled by reducing the response time for the thrusters or increasing the response from the main generators if possible.

As of today I have not found it normal that dynamic system behaviour is clearly specified in building contracts. Based on selection of equipment properties and the tuning on board the owner / yards could end up with vessels with somewhat unpredictable dynamic response capabilities for various modes but still within contract and class rules.

### ***3.10 Experimental results from measurement of thruster response for actual vessels***

To ensure that the data and times discussed in this thesis is as realistic as possible several equipment and system designers as well as ship owners have been approached and asked to provide actual measurements and data for actual vessels.

I have got several replies but only two replies from actual vessels where the owner have replied to my complete enquiry forms.

As some of these data potentially could be business sensitive they are not included in my thesis, but only referred to in general.

Below you find example of enquiry forms that have been made and sent ship-owners. In my future work I propose that such enquiries and data collection is continued to have more support data. I therefore include the forms I have developed for guidance. The results are found in appendix but not included in the electronically version of this thesis

### 3.10.1 Typical enquiry forms with question made for individual vessels:

Questions related to thrust response:			
<b>Vessel:</b>	Signal Letters:		Vessel Type:
Loa: xx m	B: xx m	Draught: xx m	GT (ITC 69):

#### General Questions to Master and Chief Officer:

In the event of manoeuvring in challenging weather or in an emergency situation, what is your expected and desired response rate for your thruster / propulsion system? (Time from you give the bridge order until "full" propeller effect.)

(Try to answer this question before you do the below actual measurements, as we would like to understand your perception of the vessel and possible input for future change)

	Bridge Order:	Expected Propeller system response time for this vessel	Desired response time
<b>Main Propulsion</b> Variable RPM mode	0-100% fwd	.....seconds	.....seconds
	100% fwd-0	.....seconds	.....seconds
	0- 100% aft	.....seconds	.....seconds
	100% aft to 0	.....seconds	.....seconds
<b>Main Propulsion</b> Fixed RPM mode	0-100% fwd	.....seconds	.....seconds
	100% fwd-0	.....seconds	.....seconds
	0- 100% aft	.....seconds	.....seconds
	100% aft to 0	.....seconds	.....seconds
Comment:			
<b>Tunnel thruster</b>	0 - 100%	.....seconds	.....seconds
	100% - 0	.....seconds	.....seconds
Comment:			

For diesel electric vessels the actual response you achieve might be related to the number of generators on line, and available for start up (as well as different modes) and how many thrusters that are simultaneously requesting power.

To what degree are you aware of this effect (power limitation)?

...

...

...

In a situation with reduced generators on line and automatic load dependent start-up of generators, what are the maximum time you could allow to gain 0-100 % main propulsion effect?.....Seconds, and 0-100% side thrust effect .....Seconds

**Questions related to thrust response:**

<b>Vessel:</b>	Signal Letters:	Vessel Type:		
Loa:	B:	Draught:	GT (ITC 69):	
Wind state:	Sea State:	Approximate actual draught: .....m		
Thruster Type:	Propeller diameter:	Effect:	Fixed RPM: .....rpm	Thrust obtained by:

In the Following Test we would like to map the effect curve for the thruster and if possible also time delay from the order to new pitch/effect is reached.

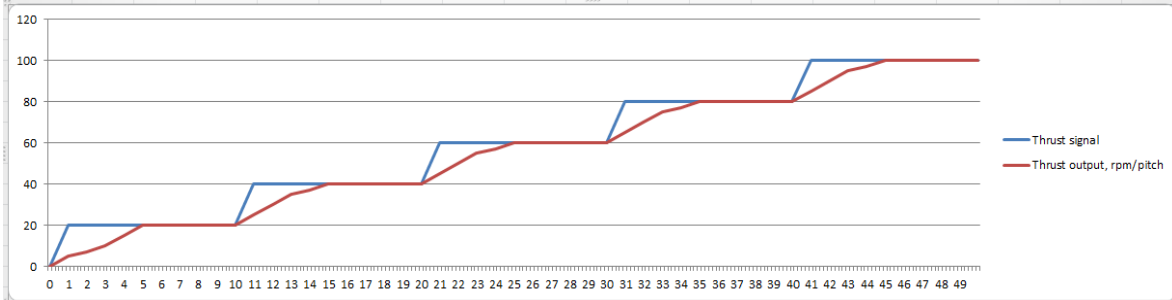

<b>Thrust towards Starboard:</b>						
Bridge Order	0 %	0 - 20%	20 - 40%	40 - 60%	60 - 80%	80 - 100%
Pitch response	NA	.....sec	.....sec	.....sec	.....sec	.....sec
Thruster effect	.....Kw	.....Kw	.....kw	.....Kw	.....Kw	.....Kw
Thruster effect	..... V	..... V	..... V	..... V	..... V	..... V
Thruster effect	..... A	..... A	.....A	..... A	..... A	..... A
Thruster rpm						
<b>Thrust towards Starboard:</b>						
Bridge Order	0%	0 - 20%	20 - 40%	40 - 60%	60 - 80%	80 - 100%
Pitch response	NA	.....sec	.....sec	.....sec	.....sec	.....sec
Thruster effect	.....Kw	.....Kw	.....kw	.....Kw	.....Kw	.....Kw
Thruster effect	..... V	..... V	..... V	..... V	..... V	..... V
Thruster effect	..... A	..... A	.....A	..... A	..... A	..... A
Thruster rpm						

In the following test we would like to find the response time for the thruster with a bridge order from 0-100% and from 100-0%. If possible we would like you to observe both the Pitch feedback and the effect measurements

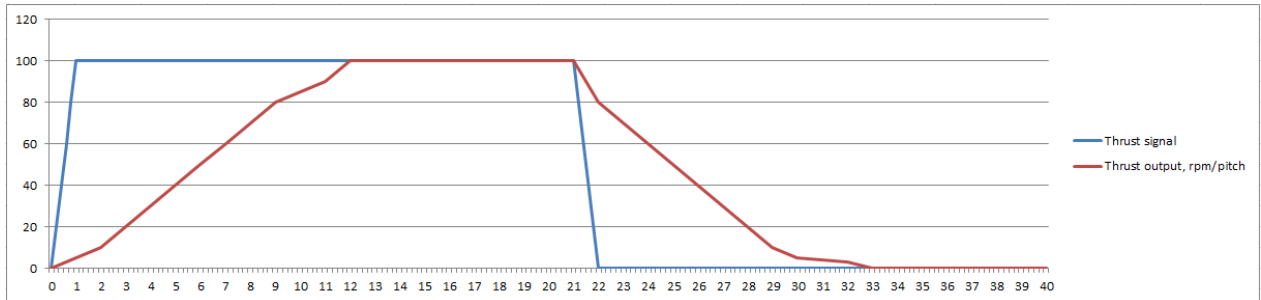

<b>Thrust towards Starboard:</b>		
Bridge Order	0 – 100 %	100-0%
Pitch response/ effect change	.....sec	.....sec
<b>Thrust towards Port:</b>		
Bridge Order	0 – 100 %	100-0%
Pitch response/ effect change	.....sec	.....sec

If possible we would like to record the following In calm weather and the initially at stand still (vessel not moving and if any wind, heading up against the wind)

<b>Thrust towards Starboard:</b>	
Bridge Order	0 – 100 %
Vessel heading change 10 deg.	.....sec
Vessel heading change 20 deg	.....sec
Vessel heading change 30 deg	.....sec
Vessel heading change 40 deg	.....sec
<b>Thrust towards Port:</b>	
Bridge Order	0 – 100 %
Vessel heading change 10 deg.	.....sec
Vessel heading change 20 deg	.....sec
Vessel heading change 30 deg	.....sec
Vessel heading change 40 deg	.....sec

Place:	Date:
Master sign:	Chief Sign:



<b>Main Propeller thruster response test</b>			<b>Fixed RPM Mode (if Applicable)</b>
<b>Vessel:</b>	Signal Letters:	Vessel Type:	
Loa:	B:	Draught:	GT (ITC 69):
Wind state:	Sea State:	Approximate actual draught: .....m	

Propulsion reduction gear:	Propeller Ø:	Propeller RPM: Min:..... Max:.....
Generators on switchboard:	kW/kVA available during test: .....kW/kVA	

In the Following Test we would like to map the effect curve for the thruster and if possible also time delay from the order to new pitch/effect is reached.

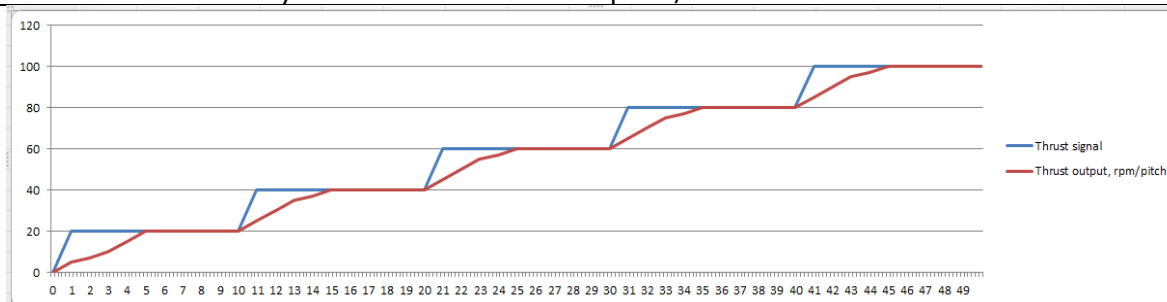

<b>Fwd Thrust:</b>						
Bridge Order	0 %	0 - 20%	20 - 40%	40 - 60%	60 - 80%	80 - 100%
Pitch response	NA	.....sec	.....sec	.....sec	.....sec	.....sec
Thruster effect	.....Kw	.....Kw	.....kw	.....Kw	.....Kw	.....Kw
Thruster effect	..... V	..... V	..... V	..... V	..... V	..... V
Thruster effect	..... A	..... A	.....A	..... A	..... A	..... A
Thruster rpm						

<b>Aft ward Thrust:</b>				
Bridge Order	0%	0 - 20%	20 - 40%	40 - 60%
Pitch response	NA	.....sec	.....sec	.....sec
Thruster effect	.....Kw	.....Kw	.....kw	.....Kw
Thruster effect	..... V	..... V	..... V	..... V
Thruster effect	..... A	..... A	.....A	..... A
Thruster rpm				

We will therefore ask you to perform the following test in fixed RPM mode. 0-100% rapid bridge order, time to achieve "full" pitch (you don't have to wait for the vessel speed to increase and build up full effect, and be careful so the vessel don't gain to much aft ward sped)

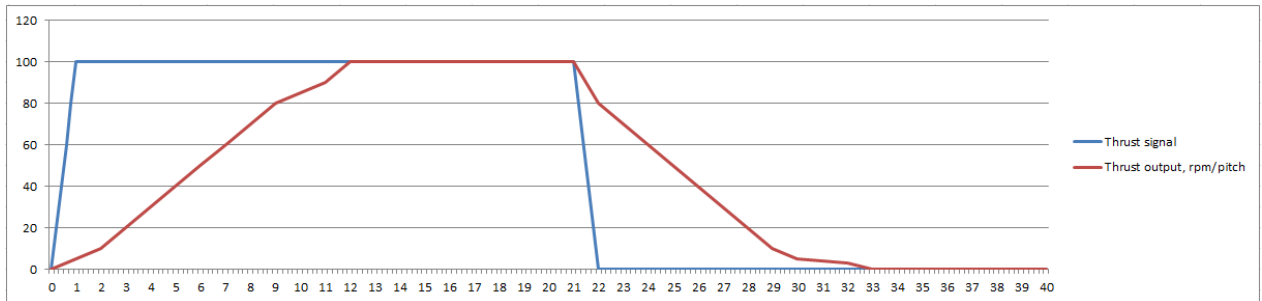

	Bridge Order:	Pitch: Measured response at propeller:	Time for the vessel to obtain 5 knots
Main Propulsion	0-100% fwd	.....seconds	.....min.....seconds
	100% fwd-0	.....seconds	NA
	0- 60% aft	.....seconds	NA
	60% aft to 0	.....seconds	NA
Comment:			

Main Propeller thruster response test			Variable RPM Mode
<b>Vessel:</b>	Signal Letters:	Vessel Type:	
Loa:	B:	Draught: m	GT (ITC 69):
Wind state:	Sea State:	Approximate actual draught: .....m	
Propulsion reduction gear:		Propeller Ø:	Propeller RPM: Min:..... Max:.....
Generators on switchboard:		kW/kVA available during test: .....kW/kVA	
In the Following Test we would like to map the effect curve for the thruster and if possible also time delay from the order to new pitch/effect is reached.			

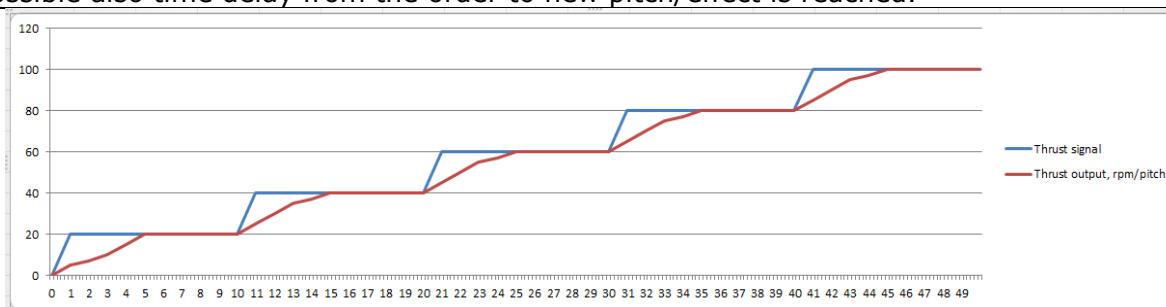

<b>Fwd Thrust:</b>						
Bridge Order	0 %	0 - 20%	20 - 40%	40 - 60%	60 - 80%	80 - 100%
Pitch response	NA	.....sec	.....sec	.....sec	.....sec	.....sec
Thruster effect	.....Kw	.....Kw	.....kw	.....Kw	.....Kw	.....Kw
Thruster effect	..... V	..... V	..... V	..... V	..... V	..... V
Thruster effect	..... A	..... A	.....A	..... A	..... A	..... A
Thruster rpm						
<b>Aft ward Thrust:</b>						
Bridge Order	0%	0 - 20%	20 - 40%	40 - 60%		
Pitch response	NA	.....sec	.....sec	.....sec		
Thruster effect	.....Kw	.....Kw	.....kw	.....Kw		
Thruster effect	..... V	..... V	..... V	..... V		
Thruster effect	..... A	..... A	.....A	..... A		
Thruster rpm						

We will therefore ask you to perform the following test in variable RPM mode. 0-100% rapid bridge order, time to achieve “full” pitch and RPM (you don't have to wait for the vessel speed to increase and build up full effect, and be careful so the vessel don't gain to much aft ward sped)

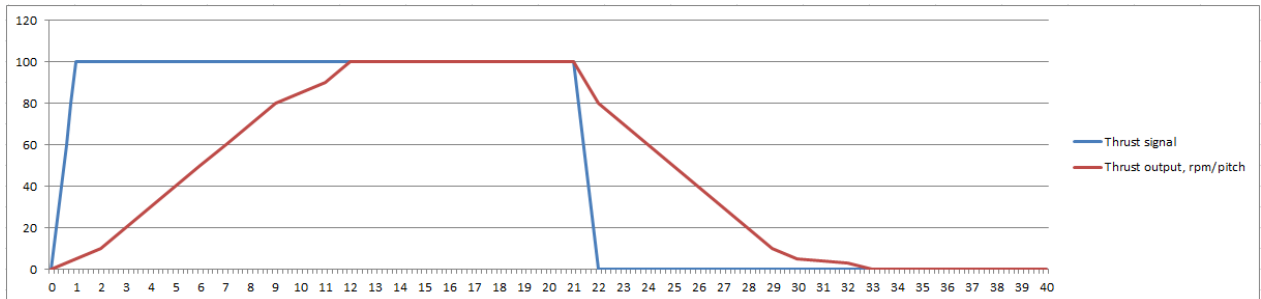

	Bridge Order:	Pitch: Measured response at propeller:	Time for the vessel to obtain 5 knots
Main Propulsion	0-100% fwd	.....seconds	.....min.....seconds
	100% fwd-0	.....seconds	NA
	0- 60% aft	.....seconds	NA
	60% aft to 0	.....seconds	NA
Comment:			

### 3.10.2 Test Results

Typical enquiry forms to owners and equipment manufacturers might be found in Appendix for the paper version.

As Actual data have been received from only a limited number of vessels, and some of these data could be regarded as potential industry secrets they are not listed in this assignment.

It should also be mentioned that the tests on board have been conducted by the crew only, and for some tests the crew have misunderstood the intention of the test and what should have been logged.

Below you will find a general summary of these results. They are presented as indications and are not vessels specific. The results for the vessels we have collected date from varies for different vessels, modes and set ups.

The results for a typical Side thruster 600-1000 kW varies from about 4,5 seconds to 22 seconds from 0-100% load and 4,5 to 10 seconds from 100- 0% ramping down time. The fastest thruster was a directly started thruster with fixed rpm and variable pitch.

For main propulsion system the test is performed on both traditional propulsion systems with a main engine, gear and a main propeller with adjustable pitch and for diesel electric driven thrusters and main propellers. The effect for the main propulsion drives and thrusters have been around 2000 kW and for the main engine driving the main propulsion line around 4-5000 kw.

The test results varies from about 19 seconds to 38,5 seconds from 0% to 100% thrust build up, and a ramping down time of about 8-11 seconds, quite similar for both traditional propulsion and diesel electrical driven thrusters.

(The traditional single line propulsion system tested with 4000-5000kW main engine ended up with 0-90% pitch/load time of about 20 seconds, and de rating time from 90% to 0% in about 10 seconds.)

The data is collected from very few vessels and more research related to what is actually normal thrust build up times should be performed.

### **3.10.3 Discussions of the results**

For a conventional main engine that is selected according to the propeller (eventual with a power take out shaft driving a shaft generator) the load up time should be adjusted to the main engines capability. And the test results indicate results close to what are the engine manufacturers guide for maximum capacity (around 20 seconds 0-100% for a diesel engine.)

For a diesel electric system the various thrusters need to be adjusted according to normal load combinations seen in relation to the number of running machinery in the various modes. i.e. if you are only running one main generator of about 2000 kW and you load up two main propulsion thrusters of 2000 kw from 0-50% you could not do this faster than about 15-20 seconds not to dynamic overload your only engine connected to the MSB, this will end up with response time of about 35-40 seconds from 0-100% similar to what is highest result from the actual measurements.

So the measured differences in times for various modes are explainable and reasonable.

In short, the results indicate that if you have running generators with static effect according to desired propulsion power, the diesel engine response curve might be followed. If you have running generator power higher than the requested power you might increase the load faster this seems to fit with my assumption given in section 4.8.

More research should be done, and results from an actual vessel at the new building stage where we have control and might log all parameters for load variations in different modes should be done to better understand the relationship and the damping effect in the systems etc.

## **PART 2 – (PROPOSED METHODS)**

### **4 USE THE MAIN PROPULSION MACHINERY AND THRUST RESPONSE RELATIONS. TO EVALUATE THE VESSELS DYNAMIC CAPABILITIES**

As shown in Part 1 the selection of main machinery and operation modes for a vessel will influence its dynamic behaviour. The designers and owners, are not always fully aware of the consequences of their selection of various main machinery and equipment.

The above study and investigation have enabled me to better understand the various systems that have consequences for the dynamic behaviour of the vessel, how these systems are controlled, interlinked and dependent of each other.

In this part I will use my acquired system knowledge for main propulsion machinery and thrust response relations to propose some merit categories for main machinery, and propose two methods for ship designers to select equipment. I will focus on the consumers/thrusters and the main generators/producers of power.

All other systems (in between) as control system, transformers, drives etc. will have to be selected/designed, adjusted and tuned accordingly.

#### ***4.1 Method description***

There are normally several system designers from various manufacturers involved, and the responsibility is as discussed in Part 1 not always clear. If further work, prove that the proposed merit factors covers the normal selection ranges, such a merit factor system is believed to be helpful to categorise equipment and enables you to refer to these in building specifications and contracts etc.

Selecting main propulsion machinery and thrust response, and match their relations are crucial in ship design. This will have consequences for the vessels behaviour.

Below you find two simple design procedure related to selecting the right thruster and main machinery properties.

Method 1 is based on that you have a clear understanding of the requested operational limits/window your vessel will have to operate within, and use modern dynamic simulation tools to find out your needed thrust response and load cases.

Method 2 is based on traditional static tools, and an evaluation of your dynamic behaviour needs as well as typical expected load cases and variations.

Both methods make reference to the systems merit factors described in this chapter.

#### 4.1.1 Method 1: Advanced method by use of dynamic simulation tools:

1. Understand the vessels required dynamic behaviour in a given dynamic weather or fault situation.

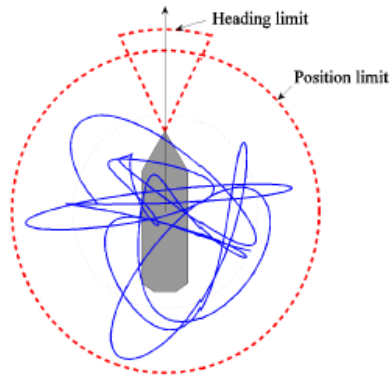

**Figure 4-1, Position and heading limits illustration from DNVGL-ST-0111.**

This could be done by running modern tools as DynCap and you could test out various propeller effects and different ramping times as well as understand the actual load cases that will apply for your vessel.

2. Select thrusts from the merit table that is able to give you the desired response.

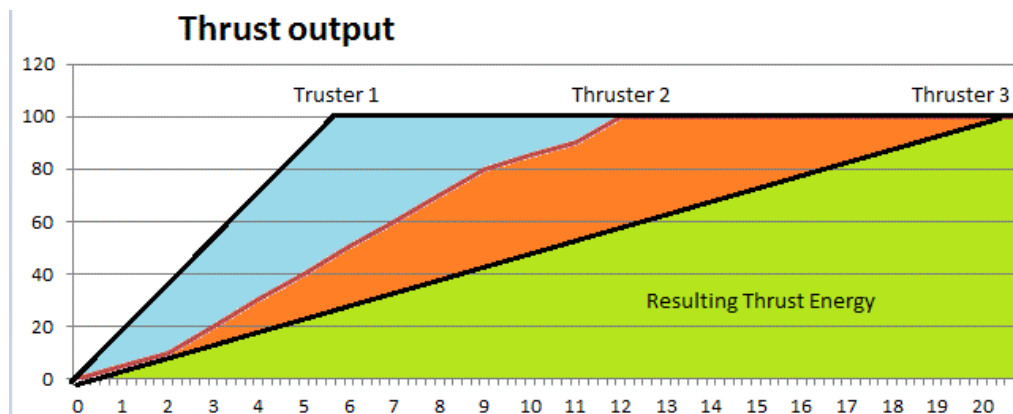
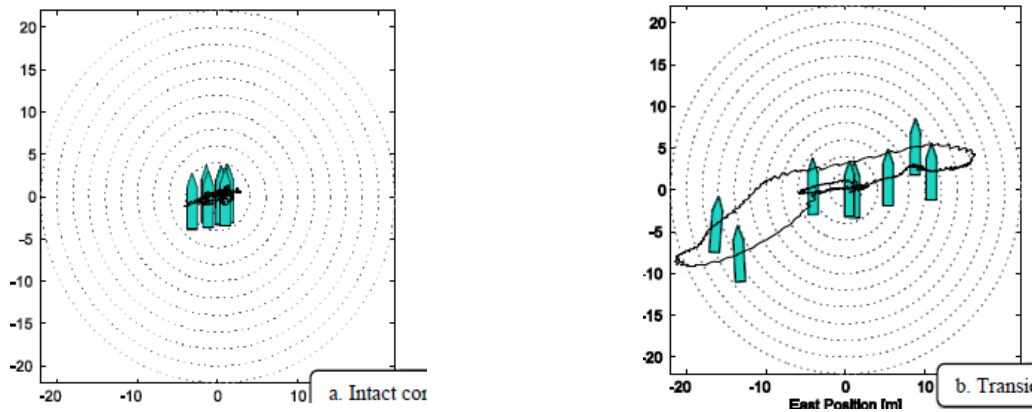

**Figure 4-2, Various thrust merits, ramp up times**

3. Use the acquired knowledge about realistic load cases to establish your dynamic and static power requirements.
4. Evaluate redundancy requirements and propose applicable modes for main machinery and select main generators according to your dynamic and static load curves.

#### 4.1.2 Method 2: Simplified method by use of standard load cases and thrust response times.

1. Use traditional static tools as the free DP Level 1 software from DNV GL or ShipX to establish the thruster requirements, evaluate the dynamic factor (reserve) and evaluate the vessels dynamic requirements.



**Figure 4-3, Illustrations from Smogeli et. al The next level DP**

2. Select thrusters from the merit table that you believe will give you the desired dynamic behaviour.
3. Use the proposed load cases, or establish other realistic load combinations from the various thrusters and consumers and establish the dynamic and static power needs.
4. Evaluate redundancy requirements and propose applicable modes for main machinery and select main generators according to your dynamic and static load curves.

#### 4.2 Dynamic merit factor for the vessel, “D-ERN”

Method 1 could possibly be further developed to make a dynamic merit factor for the vessel or a Dynamic ERN number related to a set of fault criteria’s and a given weather something like  $D_{(5m/5deg, 10m/10deg, 15m/15deg, 20m/20deg)}$  ERN

DNV GL has done something similar to this in their new ST-0111 standard and DP level 3 and defined a scenario of +/- 3 degrees of heading and a circle of 5 meter.

This systematic could be further developed to create a better dynamic classification system for the vessels and show their properties.

Method 2, could also be developed into a simplified reference numbering system for the vessels dynamic machinery capability, but will of cause don't state anything related to the vessels dynamic movements.

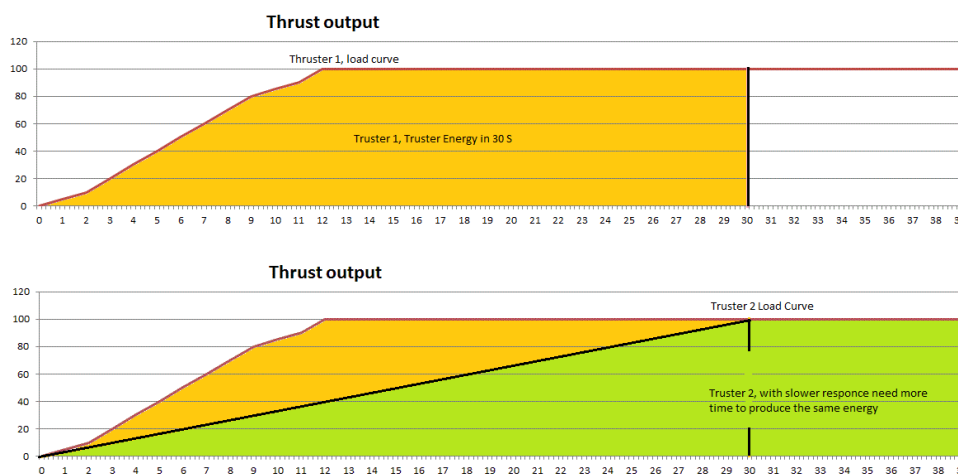

**Figure 4-4, Variable thrust ramp up times result in variable time to get the equivalent energy applied.**

This is further discussed under proposed work and in the summary



### 4.3 Main machinery Dynamics and proposed Merit Factor categorization

#### 4.3.1 Evaluation of thrust requirements and Thrust build up times

As mentioned above you could use modern dynamic simulation tools to establish your needed thruster configurations and by experimenting with the model find the optimum power needs and dynamic behaviour for the thruster.

Or you could from your traditional static evaluation tools balance the forces and creating static capability plots, evaluate the dynamic factor used and the compare the dynamic weather or eventual fault modes and evaluate the needed time for building up needed thrust to establish new balance.

The later method implies that you need to evaluate the changed criteria, the vessels inertia, hydrodynamics, speed build up and time for building up sufficient thrust forces to stop the movement and establish new balance. This is of cause not easy and you will have to base your assumptions on experience or simply by selecting the available equipment based on the vessels dominant operation criteria's.

#### 4.3.2 Proposed Thruster loading capacity classification index

The below table is a proposed categorization of thrusters power and thrust build up times. The times are based on my understanding of the thruster's actual capabilities, and partly based on actual tests referred to in Appendix A and what various types of main engine configuration and thruster configuration could expect .

Manoeuvring thrusters size in kW		Thrust load ramping times in Seconds			
>	<	A	B	C	D
0	250	2	4	6	8
250	700	4	8	12	16
700	1200	6	10	15	30
1200	1800	9	15	20	40
1800	2400	12	20	30	60
2400	3000	20	30	40	80
Approximately Thrust ramping kW/s		150	100	75	35

**Table 1, Proposed Thrust power build up time categorisation**

A Category A thrusters will in most configurations need to have more running machinery power than the actual max thruster power to be able to manage the high dynamic loads. Alternatively a stored energy source as a battery or an advanced flywheel solution could be installed to handle the dynamic variations

Thrusters in Category B/C follows more or less the curve as for a diesel engine for the same size and Category D thrusters have slower response and could be operated with less or slower running machinery.

The above explanation is only meant to illustrate the loading rates, the combination of thrusters and the applicable load case should be checked to find the resulting load rate curve and checked according to applicable modes as described later.

There could of cause be made thrusters that do not fit into this table, possible Voith Snider thrusters and water jets are able to have even higher dynamic capabilities than A category.

More research should be done to ensure that we find a table that does not exclude new and novel designs.

**4.3.3 Proposed Thrust Load Cases**

The below load cases are meant as examples, actual load cases based on the actual vessel operation profile and requirements should be established.

But as indicated in this study the resulting dynamic load from your thrusters depends on how many thrusters you intend to operate simultaneously and not how high you actually load them.

As explained in Part 1 the actual dynamic loads varies from the different types of thrusters selected as well as the response rate selected. More study should be made related to this to create better power curves for various thruster types linked to the above response time categorization.

Also typical dynamic loads for manoeuvring to and from harbour should be further investigated

Proposed examples for load cases to be evaluated:

Load Case	Thruster configuration and load changes
1	All propulsion power 0-100% (Extreme)
2	MP + side thrusters 0-67% (Manoeuvre Mode extreme)
3	MP 0-50% + Side thrusters 0-100 % (Manoeuvre mode 1)
4	MP 0-50% + 2 biggest Side thrusters 0-100 % (Manoeuvre mode 2)
5	50% - 100% of 1 MP + Largest side thrusters group from 50-100% (DP Fault)
6	...

**Table 2, Proposed Load Cases**

Based on the load cases the actual dynamic power builds up curve for your thruster configuration to be established. This curve should be used and compared to your power generation dynamic capabilities in various modes.

**4.3.1 Proposed main generator dynamic Load Capability classification Index.**

The below table is based on study of engine manufacturers guidance for loading rates as well as class rules expectations and requirements. Not all engine manufacturers openly shear their recommended loading rates, and when questioning some of the dealers they don't have any clear answers or recommendations, but states that they fulfil the class requirements.

As discussed in Part 1, class have quite strict requirements for dynamic behaviour for diesel generators, but are opening up for the possibility that your control system might handle the load variations and thereby accept slower response rates.

Wärtsila is openly sharing their response rates in their product guidance and is also stating clear requirements to the vessels control system for handling both loading up and down times. This study will focus on the loading up times but it is clearly stated that large load reductions from high load should also be performed gradually.

Wärtsila states that in normal operation the load should not be reduced from 100% to 0% in less than 15 seconds for several of their engines. This is of cause difficult if not impossible in fault scenarios with tripping of breakers, but should be considered for normal operations.

Wärtsilä is also for several of their engines having 2-3 recommended loading curves, one that typically states what the engine is capable of in an emergency situation and other for normal operation.

The above need to be seen in relationship with the operation profiles of the vessel i.e. how many dynamic loading variations of the main generators that are expected. This could have effect on the maintenance requirement for the engines as well as the related systems.

The table below is therefore divided into Emergency mode with only occasional load changes as crash stop scenarios etc. and Manoeuvring mode where it is more normal with several load changes within a given time frame.

Engine loading rates or transient load capabilities index																
		Time to stable condition														
		A1	A2	B1	B2	B3	B4	C1	C2	C3	D1	D2	D3	D4		
	Load Steps	Time [s]	Time [s]	Time [s]	Time [s]	Time [s]	Time [s]	Time [s]	Time [s]	Time [s]	Time [s]	Time [s]	Time [s]	Time [s]		
EM MODE (diesel)	0-100%	5,0	5,0	10,0	15,0	20,0	20,0	20,0	20,0	20,0	20,0	30	30	30		
Only occasional	0-50%	3,0	3,0	5,0	7,5	10,0	10,0	10,0	10,0	10,0	10,0	15	15	15		
Load Changes	50-100%	3,0	3,0	5,0	7,5	10,0	10,0	10,0	10,0	10,0	10,0	15	15	15		
	0-33-66-100%	3,0	3,0	5,0	5,0	7,5	7,5	7,5	7,5	7,5	7,5	10	10	10		
MANOUEVER	0-100%	5,0	10,0	15,0	20,0	30,0	60,0	80,0	80,0	120,0	160,0	180,0	270,0	360,0		
MODE	0-50%	3,0	5,0	5,0	7,5	15,0	20,0	20,0	20,0	20,0	25,0	30,0	30,0	30,0		
Several Load Cases	50-100%	3,0	5,0	7,5	10,0	20,0	40,0	60,0	60,0	100,0	140,0	150,0	250,0	330,0		
in a 30 min period	0-33-66-100%	3,0	3,0	5,0	5,0	10,0	15,0	30,0	40,0	60,0	80,0	100,0	130,0	160,0		
		EM Gen		Typical generators for diesel electric propulsion												
		Diesel Engines														
		Dual Fuel Engines														
		GAS engines														
Typical Engine size		250-1500 kW			500-2000 kW			1500-6000 kW			5000-12000 kW			8000 - 20000 kW		
Typical kW/s		250			200			60			30					
		Generators that possible should be supportet by accumulated energy source to cope with system the dynamic requirements														

**Table 3, Proposed Generator Loading merit index**

The table also indicate a very rough estimated expected power range for typical engines in the different categories as well as what size that is my understanding of normal engines used for generators today. It also indicates dual fuel (DF) engines that could automatically switch to diesel in case of dynamically “overloaded” and gas engines.

It also indicated bigger engines and gas engines tend to have a slower response rate and recommended load rate, and this should be taken into considerations selecting such arrangements. Possibly such engine installations need some kind of stored energy as battery or flywheel arrangements to handle dynamic load variations. This will also be beneficial in a maintenance perspective. This will be better illustrated in the next section when you compare actual operation modes.

**4.3.2 Proposed early design stage mode evaluation system**

When you have selected your thruster configuration and the applicable load cases as well as understand the remaining vessels power demand in the various operation modes you might draw up the dynamic power demand curves for the various modes of operation or faults scenarios.

Depending on your requirements for separation and redundancy as well as the MSB and system configuration the dynamic power demand curves could be made for individual sections of the switchboard or if you operate with closed bus ties you could evaluate this for your whole system.

By evaluating this in an early design phase you might configure modes and main power generating machinery configurations as well as defining the need for power accumulator effects to be able to handle dynamic variations with as little running machinery as possible.

In the below you find an example where you have 4 generators of about 200kW effect available, “B2” engines from the proposed table above and some given load cases for the thrusters (simplified and not taking into consideration the hotel load of the vessel or actual loading curves from the thrusters, considered linear).

Depending on your how high up you load your thrusters you find that you will need 3 or 4 engines running to be able to have sufficient power available, You also find that the dynamic curve is below the resulting curve for 3 engines but above the curve for two engines. This implies that to not “overload” the engines in the dynamic range you should have at least 3 generators running.

If you chose to allow for a mode with minimum two engines connected and a load dependent start for number 3 and 4, you will slightly exceed the dynamic recommendations for your engine, and you should evaluate how often you will operate the vessel in these modes, and evaluate if you should install a power source that could supply the energy need found by the difference of integrated area between these curves.

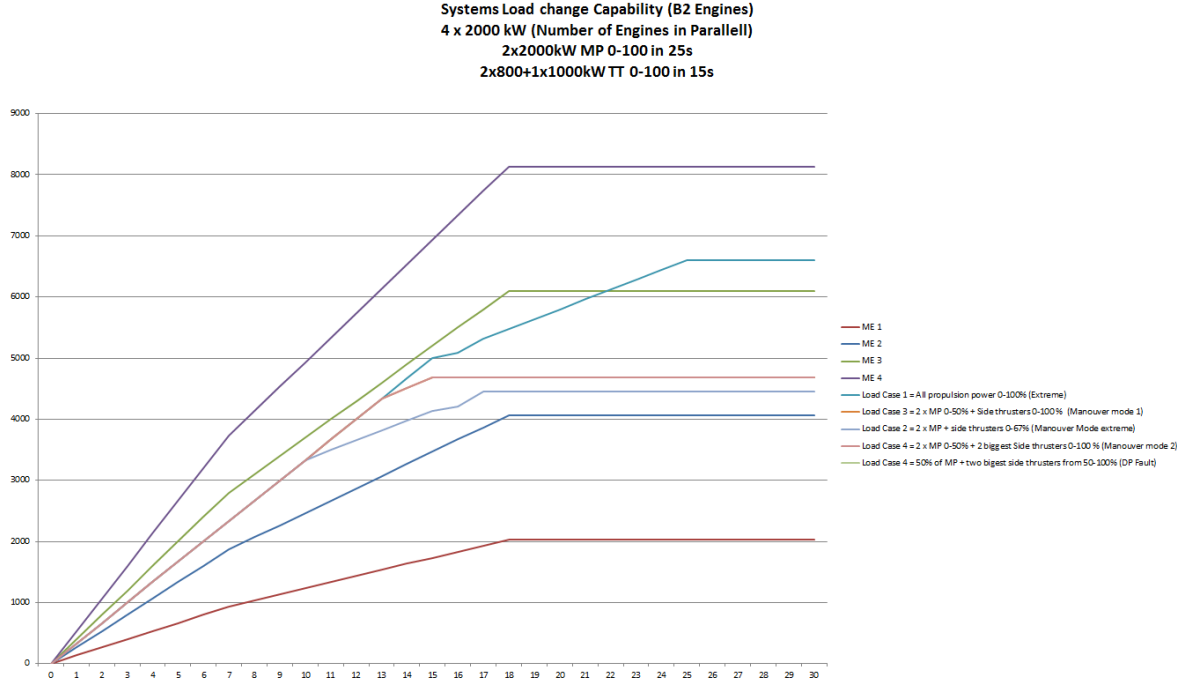

**Figure 4-5, System Load change Capability and mode selection**

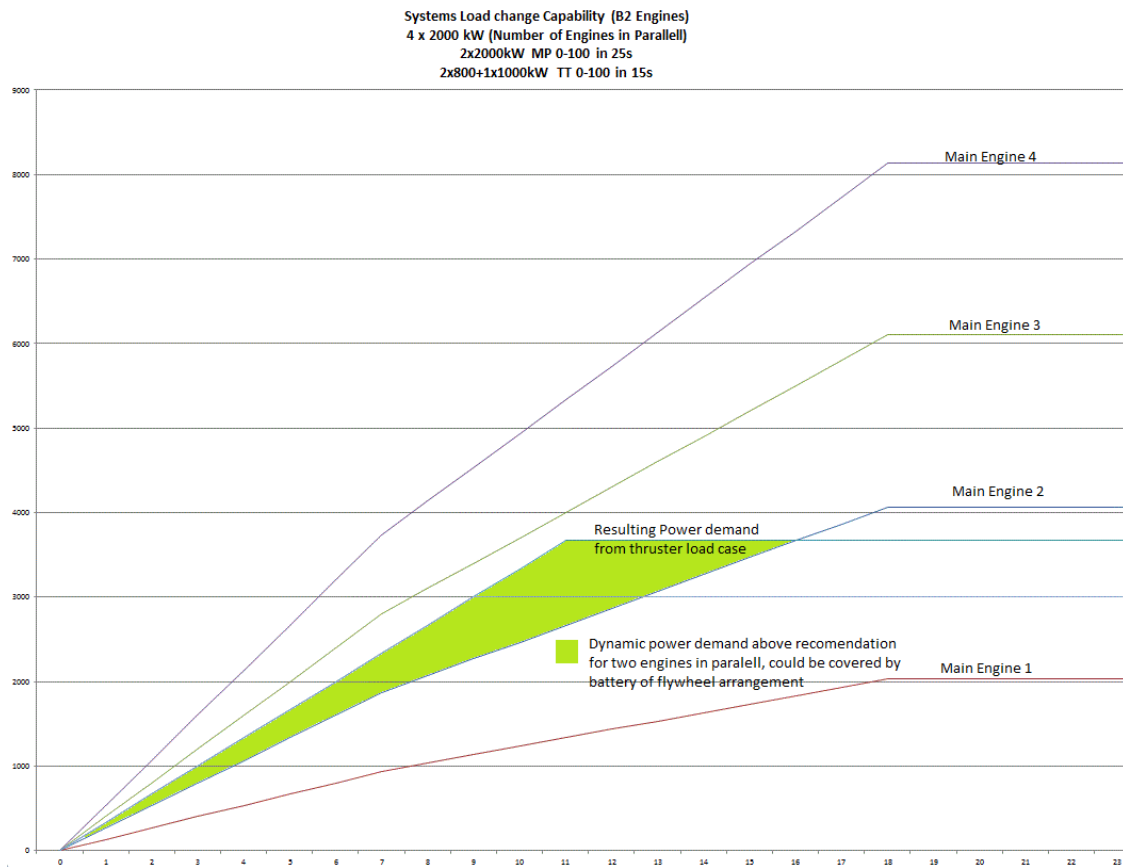

**Figure 4-6, Indication of accumulated dynamic energy need if Mode with 2 generators is selected**

I have made a simple Excel sheet to select and construct the various dynamic properties from. A better tool should be developed to easier select engine types and construct modes with load dependent starts and to find the area between the system curves to be able to more directly give you your requirement for stored energy if this is your selected choice.

My simple approach still indicates the dynamic behaviours you will need to consider, Development of better tools related to this is proposed for future work.

#### **4.4 Bridging the gap of traditional static design tools and modern dynamic design tools**

My approach has been to try to make a systematic approach enabling the designer to understand the relations and consequences of selecting different types of main machinery for a modern diesel electric vessel.

I find that both the traditional design tools as static evaluations with factors based on experience and the more modern dynamic simulations have their own clear advantages and could be used for different types of vessels and operations.

At an early design stage we will have to make several assumptions and have several iterative processes to develop a good machinery and control configuration.

To use modern dynamic design and simulation tools, you will also have to understand various configurations and their limitations. You will have to make assumptions and simplifications at least at an early design stage.

I therefore believe that a similar approach as the one given above, where you make a categorisation of various equipment, could be a helpful tool enable us to better predict the vessel dynamic behaviour. And such a basic system will also be beneficial for early design review with modern dynamic simulation tools.

## 5 CONCLUSIONS

This Thesis have been divided into two main parts: Establishment of, and understanding of the theory and relation between main machinery and their control systems; Proposing an early stage design configuration systematics enabling us to have a dynamic ship merit factor.

My initial idea and background for this thesis was my experience as class surveyor for several new buildings, observing how different systems are tuned and tested on board, realising that there could be conflict of interests among the various parties involved.

I have further realised that dynamic behaviour of equipment and vessel is seldom described in building specifications etc. and are only to some extent described in class rules. This could lead to vessels built with slow response configurations and fully be according to their contracts.

This has resulted in that equipment is tuned and tested according to the various maker's collaboration and best intentions. This could result in that the vessels full potential is not taken out. There have been cases where the owner, in the operation life of the vessel has asked for better response times, from for instance thrusters manufacturers, and have had this adjusted by the maker, without realising the implications this potential could have on the vessels previous defined modes, dynamic engine overloading, black out prevention system etc.

The initial idea for the thesis, was also to try to evaluate the actual dynamic effect variation in thrust response rates will have on a vessel in a given weather. But my literature study have made me realise that such dynamic simulation tools have already been developed and seems to be much better than what I with my limited resources would have been able to develop.

My focus have therefore ben slightly adjusted , and I have tried to realise what assumption you will need to take in such early phase time-domain simulations, as well as for traditional static early design tools only studying static capability's and dynamic allowance factors.

The background and theoretical part of thesis is partly based on the work done by Børhaug (2012) comparing the traditional static DP capability analysis with the new Dynamic Capability analysis described in proc. paper Pivano et al.(2012), the new DNV GL ST-0111 and my understanding of the assumptions and simplifications made in their work. Børhaug (2012) link his work and development of the mathematical formulas to earlier work done by Fossen (1994 to 2011) and several others.

My understanding of the various relationship and challenges for control system of propellers is partly based on the PHD Thesis by Smogeli (2006) and Pivano (2008). For main generators I have highly valued the open approach in the product guides from Warsila and information found at their web pages. Their work has been highly valued and should be consulted for the interesting reader.

As Bredhaug (2012) confirms in his work, pointing out that the dynamic simulations gives a better understanding of the behaviour of the vessel, and are able to give a better description of the actual operation window, station keeping capability of the vessels, and by this enables the various stake holders to base their decisions on more accurate data.

For a completed vessel where you have the actual response rates from thrusters in the various modes, the new dynamic tools could to my understanding give you a very good representation of the vessels movement in case of failures etc. I guess that the future DP systems on board will indicate and predict movement in different fault scenarios and include this as part of their consequence analysis. This implies that you for a given location and given vessel could calculate sea states and operation limits for several demanding operations in a much better way than before.

But to ensure that you actually operate the vessels according to the assumptions behind the calculations, you will need to interlink several control systems, or to have clearly defined modes linked to your consequence analyse. A fully integrated control system will possible be beneficial, but this is demanding as you for modern vessels combine equipment from several manufacturers.

From an early design perspective, you will have to understand and define the dynamic relations between main machinery components. In such a design loop it could be beneficial to have a dynamic categorisation system to select and specify equipment according to. This could also be used as input for time-domain simulations predicting your resulting vessel behaviour.

In this respect, I believe that my approach might be a contribution and could be further developed to support the industry.

## **6 FURTHER WORK**

As this assignment involve several traditional engineering disciplines as mechanical, electrical, control systems and dynamic behaviour it have been difficult to get a full complete understanding of all systems involved. And the work should be evaluated and checked by qualified persons for all disciplines, but apart from that I propose the following further work.

Actual dynamic power curves for the various main types of propellers with their given response rates should be further investigated and developed.

More investigations related to power/ thrust curves for typical thrust manufacturers to be collected to ensure that the proposed merit factors covers the normal range.

Typical and realistic load case scenarios showing interactions between thrusters during station keeping in demanding weather as well as in manoeuvring and fault situations to be

established. This would enable us to better define the actual dynamic power requirements for various vessel types and operations.

A tool should be developed where you could select the actual generator merits, minimum number of generators on line, load dependent start at a given level, connection time, etc. This to be able to draw up the dynamic/static load curves for the selected part of the MSB. In the same tool you should be able to draw up the various typical load cases for the thrusters as well as base “hotel” load to evaluate correct operation modes. This tool should also have the possibility to add a limited stored energy power source, ref. below.

In cooperation with the above tool, a simple early stage method and calculating tool evaluating the required stored power needs, to support main generators in the dynamic load range, to be developed. This will enable us to better utilize GAS engines at their optimum load as generator sets for vessels with high dynamic variations, such system could also be combined with normal peak shaving approach.

The effect of various thrust build up times for typical weather and manoeuvring situations should be established. The dynamic window and behaviour of the vessel and the result it has on fuel consumptions, should be evaluated with and without a battery or flywheel source of power arrangement.

The above effects should also be evaluated from a maintenance system, both from the thruster’s point of view and from the main generator system point of view. Establishment of better understanding of the main generators load curves, from various manufacturers to evaluate if the proposed merit factors, cover the range of engines in normal use.

(From a personal point of view, not directly linked to this thesis I believe that the industry still have too many thruster related damages. The thruster environment forces and understanding of its operation behaviour, its control systems as well as its mechanic interactions with its individual inertias of shafts and electric motor, could be a separate study and dynamic model.)



## REFERENCES

- [1] Literature Posted on Fronter by HIALS, Lecture notes, HIALS Machinery Systems
- [2] Børhaug, Brede. "Experimental validation of dynamic station keeping capability analysis: The next level DP capability analysis." (2012).
- [3] Smogeli Ø. 2006. Control of Marine Propellers. From Normal to Extreme Conditions. PhD thesis. NTNU.
- [4] Pivano L, 2008. Thrust Estimation and Control of Marine. Propellers in Four Quadrant Operations. PhD thesis. Faculty of Information Technology, NTNU.
- [5] DNV, DNV-RP-C205 - Recommended Practice for Environmental Conditions and Environmental Loads, April 2014.
- [6] DNV GL, ST-0111 – Standard for Assessment of station keeping capability of dynamic positioning vessels, July 2016.  
<https://rules.dnvgl.com/docs/pdf/DNVGL/ST/2016-07/DNVGL-ST-0111.pdf>
- [7] DNV GL Rules for Classification,  
[https://rules.dnvgl.com/ServiceDocuments/dnvgl/#!/industry/1/Maritime/1/DNV%20GL%20rules%20for%20classification:%20Ships%20\(RU-SHIP\)](https://rules.dnvgl.com/ServiceDocuments/dnvgl/#!/industry/1/Maritime/1/DNV%20GL%20rules%20for%20classification:%20Ships%20(RU-SHIP))
- [8] Smogeli Øyvind, Nguyen Trong Dong, Eide Kristoffer, Pivano Luca. DynCap – Full scale validation of a vessel's station-keeping capability analysis. Marine Technology Society (MTS) DP Conference, October 13-14, 2015, Houston, US.
- [9] International Marine Contractors Association (IMCA). Specification for DP Capability Plots. IMCA M 140 Rev. 1 June 2000.
- [10] Det Norske Veritas (DNV). Recommended practice DNV-RP-C205: Environmental Conditions and Environmental Loads. October 2010.
- [11] The Next Level DP Capability Analysis By Øyvind Smogeli, Nguyen Dong Trong, Brede Børhaug, Luca Pivano 2012
- [12] Lewandowski, Edward M. The dynamics of marine craft: manoeuvring and seakeeping. Vol. 22. World scientific, 2004.
- [13] Skjetne, Roger, Øyvind N. Smogeli, and Thor I. Fossen. "A Nonlinear Ship Manoeuvring Model: Identification and adaptive control with experiments for a model ship." Modeling, Identification and Control 25.1 (2004): 3-27.
- [14] Sørensen, Asgeir J., and Øyvind N. Smogeli. "Torque and power control of electrically driven marine propellers." Control Engineering Practice 17.9 (2009): 1053-1064.
- [15] Fossen, Thor I. Guidance and control of ocean vehicles. John Wiley & Sons Inc, 1994.
- [16] Rakopoulos, Constantine D., and Evangelos G. Giakoumis. Diesel engine transient operation: principles of operation and simulation analysis. Springer Science & Business Media, 2009.
- [17] Hansen, Jan Fredrik, Alf Kåre Ådnanes, and Thor I. Fossen. "Mathematical modelling of diesel-electric propulsion systems for marine vessels." Mathematical and Computer Modelling of Dynamical Systems 7.3 (2001): 323-355.
- [18] Rakopoulos, Constantine D., and Evangelos G. Giakoumis. Diesel engine transient operation: principles of operation and simulation analysis. Springer Science & Business Media, 2009.

- [19] Rakopoulos, C. D., and E. G. Glakoumis. "Sensitivity analysis of transient diesel engine simulation." *Proceedings of the Institution of Mechanical Engineers, Part D: Journal of Automobile Engineering* 220.1 (2006): 89-101.
- [20] Denny, S. B., and E. N. Hubble. "Prediction of craft turning characteristics." *Marine technology* 28.1 (1991): 1-13.
- [21] The Next Level DP Capability Analysis By Øyvind Smogeli, Nguyen Dong Trong, Brede Børhaug, Luca Pivano
- [22] Fossen, Thor I. "A nonlinear unified state-space model for ship maneuvering and control in a seaway." *International Journal of Bifurcation and Chaos* 15.09 (2005): 2717-2746.
- [23] Johansen, Tor A., and Thor I. Fossen. "Control allocation—a survey." *Automatica* 49.5 (2013): 1087-1103.
- [24] Technical note from ABB "Starting methods fo AC motors (2010) found at [www.abb.com/motorsgenerators](http://www.abb.com/motorsgenerators)
- [25] Electrical & Electronic Systems, Starting Time Calculation for Induction Motor Garg and Tomar, *J Electr Electron Syst* 2015, 4:2 <http://dx.doi.org/10.4172/2332-0796.1000149>
- [26] Hybrid Propulsion Systems for Small Ships: Context and Challenges, by N. Bennabi, J. F. Charpentier, H. Menana, J. Y. Billard, P. Genet
- [27] IEEE TRANSACTIONS ON POWER ELECTRONICS, VOL. 23, NO. 4, JULY 2008, Nonlinear State of Charge Estimator for Hybrid Electric Vehicle Battery by Il-Song Kim
- [28] Wärtsilä, Product guides for Marine Engines: <http://www.wartsila.com/products/marine-oil-gas/engines-generating-sets>
- [29] Rolls-Royce, Product guides and range, <http://www.rolls-royce.com/products-and-services/marine/product-finder/diesel-and-gas-engines/medium-speed-gensets.aspx#section-product-search>
- [30] Brunvoll, Product guides and range, <http://epub.ekh.no/b/brunvoll/2014thrusterange/#4>  
<http://www.brunvoll.no/product/brochures/attachment/2200?ts=14c4b1b1e7b>
- [31] ABB, Product guides, systems and Solutions <http://new.abb.com/marine-ports>
- [32] ABB, Low voltage motors guide, and ABB drives for marine Applications [https://library.e.abb.com/public/a7c16f0e10f4a826c1257c9000270ce0/MotorGuide\\_february2014\\_low\\_FINAL%20with%20bookmarks.pdf](https://library.e.abb.com/public/a7c16f0e10f4a826c1257c9000270ce0/MotorGuide_february2014_low_FINAL%20with%20bookmarks.pdf)  
[https://library.e.abb.com/public/2e7b508ea530471ac125785b00446c95/Marine%20brochure%20RevB\\_lowres.pdf](https://library.e.abb.com/public/2e7b508ea530471ac125785b00446c95/Marine%20brochure%20RevB_lowres.pdf)
- [33] Luebcke, Adele, Philip Augener, and Arne Falkenhorst. "A Fast Method for the Evaluation of the Dynamic Positioning Capability in Time Domain in the Early Design Stage." *ASME 2015 34th International Conference on Ocean, Offshore and Arctic Engineering*. American Society of Mechanical Engineers, 2015
- [34] Moss, Andreas Rolland. "Simulation model for an LNG ferry." (2014).
- [35] Smogeli Ø., Nguyen D., Børhaug B., Pivano L. The Next Level DP Capability Analysis. Marine Technology Society (MTS) DP Conference, October 15-16, 2013, Houston, US.
- [36] Pivano L., Smogeli Ø., Muddusetti S., Ramsey J. Better Analysis - Better Data - Better Decisions - Better Operational Risk Management = Delivery of Incident Free operations: Enabled by DynCap. Marine Technology Society (MTS) DP Conference, October 14-15, 2014, Houston, US.

- [37] Johansen, Tor A., et al. "Dynamic Positioning System as Dynamic Energy Storage on Diesel-Electric Ships." *IEEE Transactions on Power Systems* 29.6 (2014): 3086-3091. [http://folk.ntnu.no/torarnj/energy\\_storage\\_dp.pdf](http://folk.ntnu.no/torarnj/energy_storage_dp.pdf)
- [38] Peak-shaving Control of Loads on Diesel-Generators in Hybrid Electric Ships, by Christian B Finstad 2016 Msc
- [39] Luca Pivano, Martin Poirier, Per Frederiksen, Kristoffer Eide, Øyvind Smogeli - Planning of drilling operations in extreme ocean currents: experience from time-domain simulations and full-scale validation on Maersk Venturer DYNAMIC POSITIONING CONFERENCE October 11-12, 2016

## APPENDIX

**Appendix A** *Enquiry related to participation in research project (Company 1 and 2)*  
(Not included in electronically version of the paper)

**Appendix B** *Enquiry related to participation in research project (Company 3)*  
(Not included in electronically version of the paper)

**Appendix C** *Result from Vessel 1*  
(Not included in electronically version of the paper)

**Appendix D** *Result from Vessel 2*  
(Not included in electronically version of the paper)

**Appendix D** *Preliminary Research Paper*



## **APPENDIX D**

### **PRELIMINARY RESEARCH PAPER**

**Bridging the gap between traditionally static early design methods and time-domain simulation.**

**-Ship response and manoeuvrability-  
Main machinery characteristics, configuration modes,  
and its resulting effect on thrust response.**

**Proposed dynamic ship merit factor/index.**

**Arne Solevåg**



**ABSTRACT**

Design of main machinery systems and configurations have traditionally been performed by evaluation of static situations. Static main machinery and electrical load balance and static vessels capability plots/envelopes where the forces/power balances each other.

There are already today several providers of dynamic simulation tools where you could build virtual models of your vessel and perform analysis also at early design. As of today no commonly used standard way of building the various parts of the models exists, and most models includes simplifications and assumptions. If we don't properly understand the relations between main machinery components, we could end up trusting the early stage dynamic models and the resulting vessel behaviour too much.

The below work tries to generalise and simplify the dynamic relations between main machinery and their control systems, at an overall level with the intention to make a simple design tool for selecting equipment, based on their dynamic behaviour and dependencies.

A simple main machinery category and dynamic merit factors specification is system is proposed. This could be used to specify equipment according to and might be used as input in early design evaluations.

The future for vessels with dynamic position/manoeuvring systems, is believed to have full vessel specific dynamic calculating model incorporated in their control systems. These systems will calculate probable resulting deviating positions in event of failures or changed weather.

This paper propose an simple early design approach to better understand the dynamics involved

**CONTENTS**

**ABSTRACT**..... 1

**CONTENTS**..... 1

**INTRODUCTION**..... 2

**DP AND MANOUVERING SITUATIONS** ..... 2

*Vessel manoeuvring capability*..... 2

*Resulting dynamic power request from thruster configuration* ..... 3

**MAIN GENERATOR / POWER CONFIGURATIONS** ..... 4

*Generator and main switch board configuration* ..... 4

*Alternative configurations* ..... 6

**MAIN MACHINERY DYNAMICS AND PROPOSED MERIT INDEX CATEGORIZATION** ..... 8

*Proposed thruster loading capacity classification index*..... 8

*Proposed Thrust Load Cases*..... 8

*Proposed main generator dynamic load capability classification Index* ..... 9

**PROPOSED EARLY DESIGN STAGE MODE EVALUATION SYSTEM** ..... 9

**CONCLUSIONS** ..... 10

*Bridging the gap of traditional static design and modern time-domain simulations*..... 10

**REFERENCES**..... 10

## INTRODUCTION

One of the main challenges in ship design is to make sure that a vessel is able to perform its tasks in a safe and efficient manner. The industry has therefore created vessels and systems with high degree of integration between various systems and their control systems.

The result is flexible, cost effective and more environmental friendly vessels, but it have also its challenges related to higher degree of complexity and need for operational awareness and understanding.

It is therefore essential that the designer understand the interactions between the vessels different system, to be able to determine the weather operational window where the vessel can maintain its speed, heading and position within some limits.

To establish a weather window, a static analysis is normally performed by balancing the maximum obtainable thruster force against a resultant mean environmental force due to wind, wave drift, current, and possible other loads.

Important assumptions and simplifications must be done to facilitate the analysis and the dynamic behaviour of the vessel and propulsion system is normally not considered, but allowed for by having a “margin” or dynamic factor. Criteria’s for dynamic thruster response are often not clearly specified building contracts, nor in specifications.

To operate environmentally friendly implies that you have as little running machinery as possible, and that you try to run the machinery at or near the optimum design parameters. The push to operate vessels in some DP operation with closed bus tie, and depend on automatic start-up of new generators in event of failure is one example.

This could result in extended ramping times of thruster’s effect due to the main machinery dynamic limitations and power limiting until you have sufficient available power.

It is important that these scenarios and relations are known, understood and incorporated in the dynamic models of the vessel, this approach could help in this respect and possible be used as reference or evaluation in early design studies as well a standard to by equipment with various dynamic capabilities according to

## DP AND MANOUVERING SITUATIONS

### Vessel manoeuvring capability

The design of vessels result in a configuration of several thruster actuators to best solves the operation profile and design parameters for a given operation.

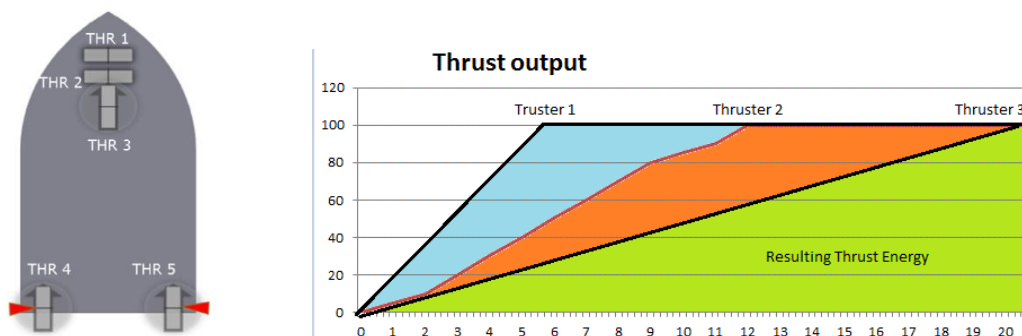

**Figure 0-1, Typical configuration of thrust actuators with various properties**



The various properties for the thruster will of cause have an effect on the vessels dynamic behaviour, as these properties will influence on the time it take to build up sufficient thrust force to maintain position or performing a manoeuvring operation.

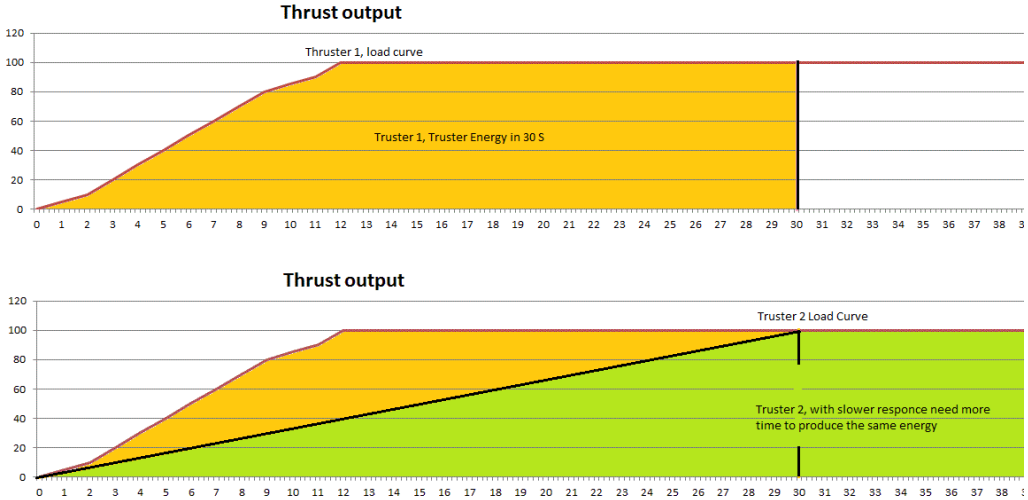

**Figure 0-2, Thrust energy time variations**

This could as described by Smogeli et al. (2012) be dynamically simulated, it is further discussed by Bredhaug(2012) and could result in a dynamic footprint for the vessel that possible exceeds the limits for a given operation.

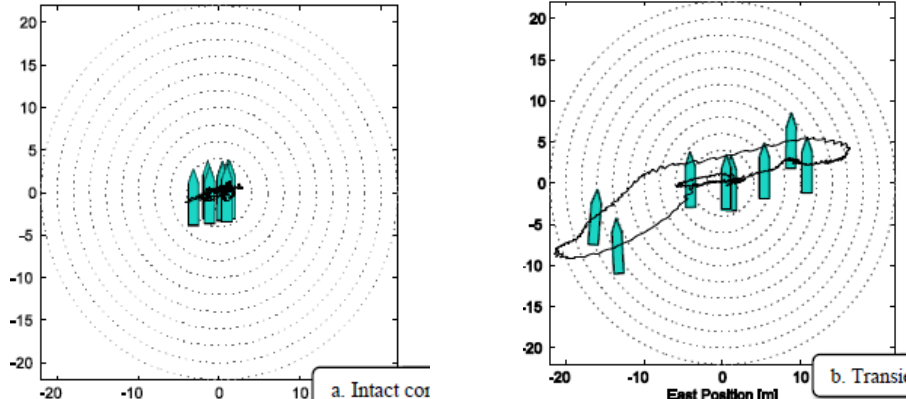
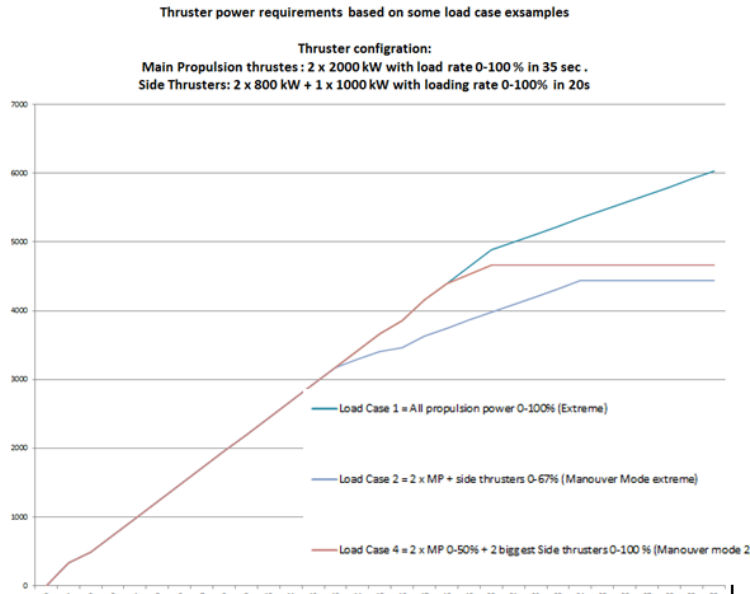

**Figure 0-3, Illustrations from Smogeli et. Al, The next level DP**

**Resulting dynamic power request from thruster configuration**

The manoeuvring or dynamic positioning as well as eventual fault scenarios for a given vessel will result in a dynamic power requirement from the vessels main machinery and generators.

Relevant load cases for the thruster configuration should be established and the resulting power demand should be plotted as indicated below.

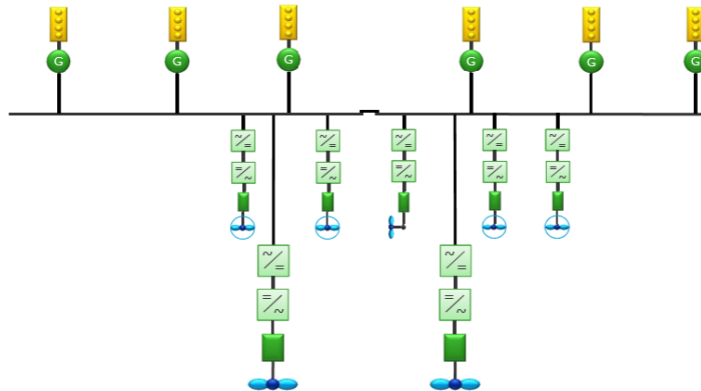

**Figure 0-4, Typical Power demand from Thrusters**

## MAIN GENERATOR / POWER CONFIGURATIONS

### Generator and main switch board configuration

The vessels main generator configuration to be evaluated, the static electrical load balance is a tool that is used to configure generator modes and main switch board configuration and separation etc. But as described below the main generators dynamic capability should also be evaluated.



**Figure 0-1, Typical Diesel electric setup**

Several engine and generator manufacturers have various modes their engines could operate in, these modes could for instance be emergency and normal operation. Dependant on the operation mode the manufacturer could have different recommendations related to dynamically loading of generator sets.

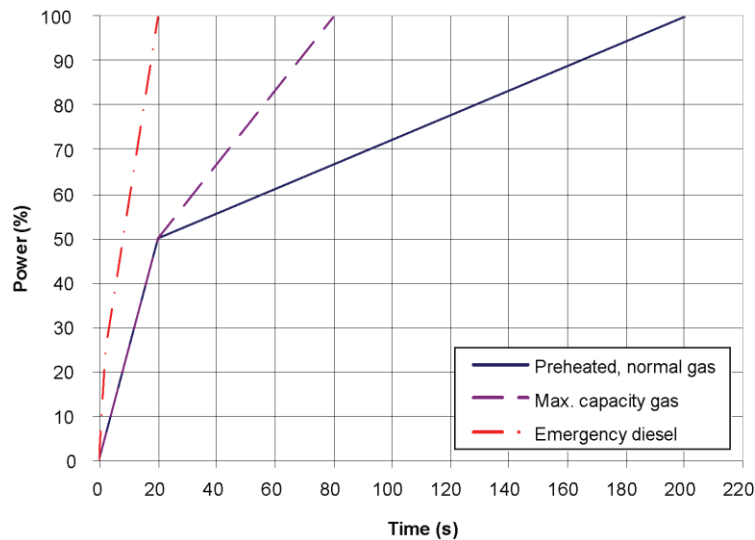

**Figure 0-2, Example of load change capability curves for a generator set**

Ref.: <http://cdn.wartsila.com/docs/default-source/product-files/engines/df-engine/product-guide-o-e-w20df.pdf?sfvrsn=4>

Resulting power generators dynamic curves for your selected mode (number of generators on line in a given section of the MSB) should be established and compared to the dynamic load cases for the same section.

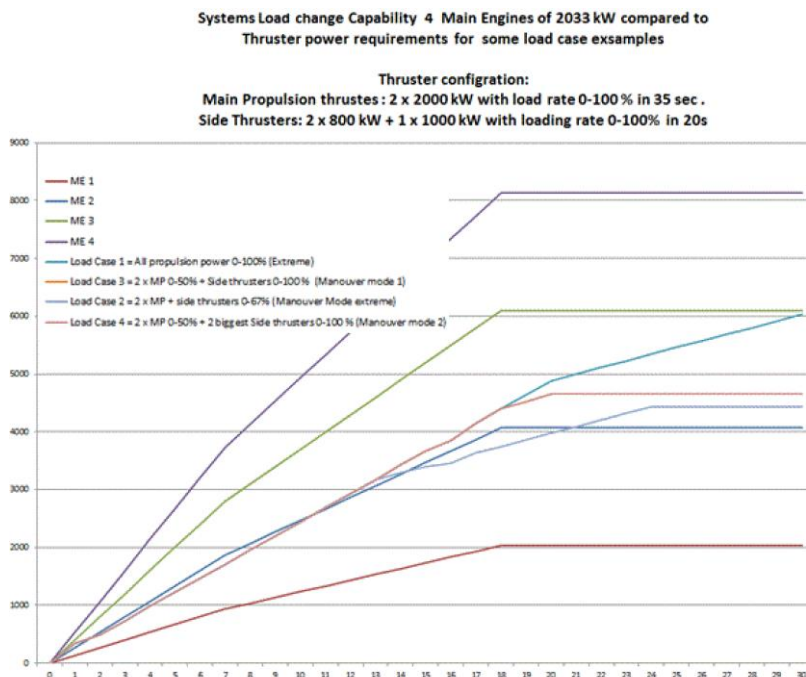

**Figure 0-3, Main Generators in parallel and typical power demand from thrusters**

In the example above we find that the dynamic power request for a given thruster configuration and load case correspond to the dynamic properties of two generators running in parallel.

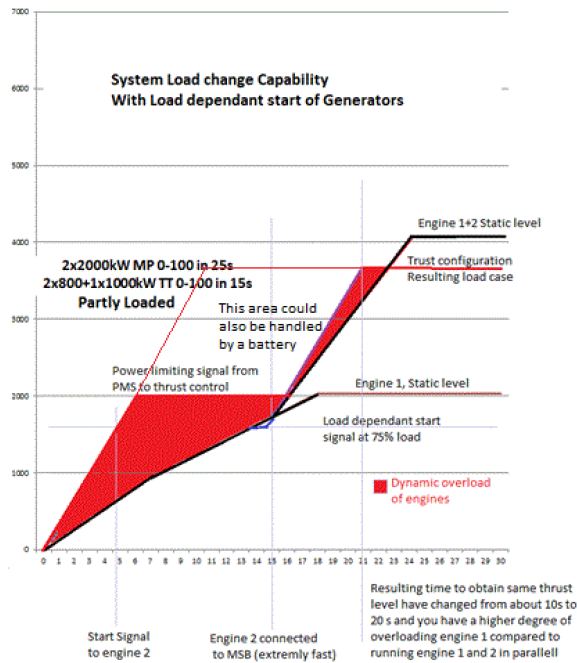

**Figure 0-4, Illustration showing one generator on line and automatic start-up of generator 2 at 75% load.**

If we in the same section of the MSB only have one generator on line, we find that this generator will be dynamically overloaded and the thrust output will be limited by the PMS system until a new generator is automatically started and sharing the load and the thrust might continue to build up.

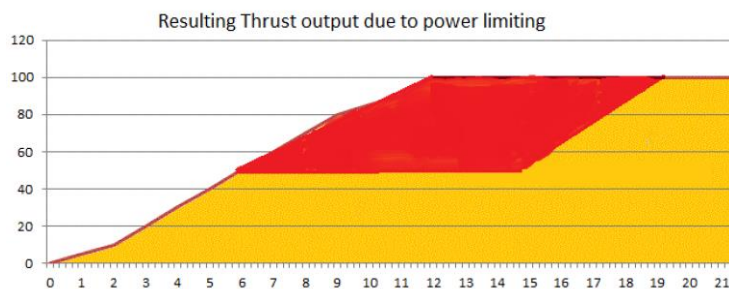

**Figure 0-5, Typically resulting thrust curve (in yellow) with power limitation signal from PMS**

These are important effects to realise and ensure that are built into the time-domain simulators.

### Alternative configurations

As seen from above this illustrates that you might come in situations where your system configurations with its various load cases exceed the dynamic properties of main power plant configuration mode. This could typically be the case with gas motors driving generator sets.

A configuration set up with some kind of accumulators (batteries or flywheel) could be a solution.

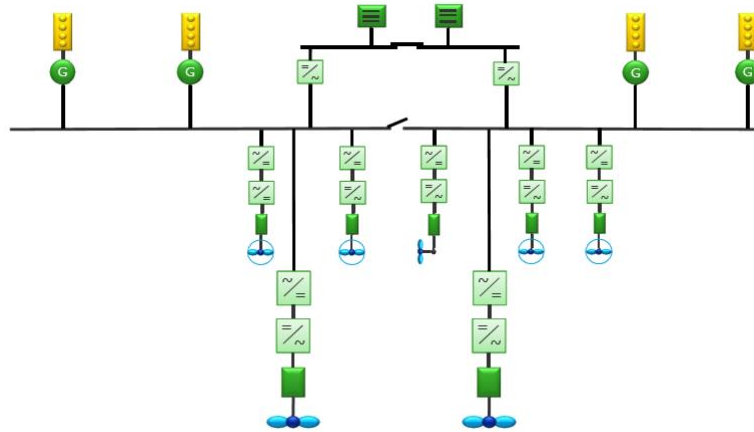

**Figure 0-6, Main Switchboard illustration with accumulated energy source**

This solution could help with the dynamic power requests, and enable you to run with less running machinery. This has several advantages, both related to maintenance and fuel/environment considerations.

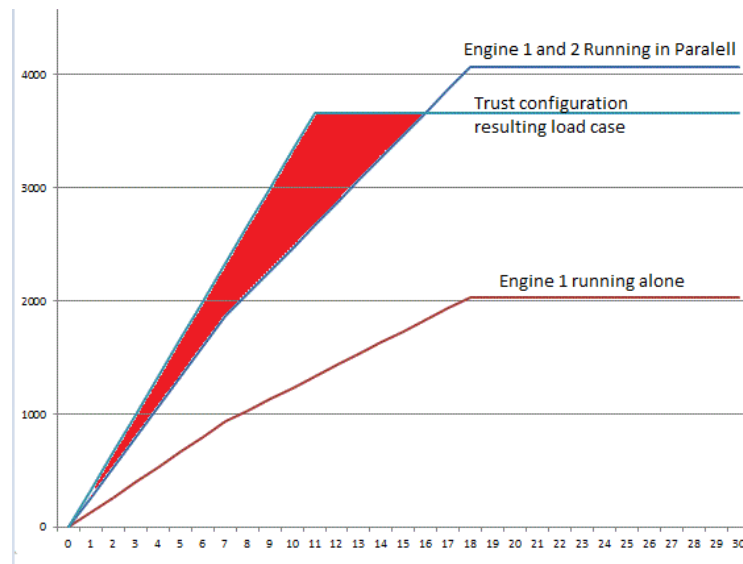

**Figure 0-7, Illustration of one side of the MSB above, two generators running in parallel and a resulting dynamic load request above their recommended load rates. This red area could be handled by a battery or flywheel installation.**

This simple method where you illustrating dynamic behaviour could help the designer and the programmer of time-domain simulation tools to take better decisions related to applicable mode and make simplifications/assumptions.

But to establish such curves it would be beneficial to have standard parameter tables for main machinery equipment.

# MAIN MACHINERY DYNAMICS AND PROPOSED MERIT INDEX CATEGORIZATION

## Proposed thruster loading capacity classification index

The below table is a proposed categorization of thrusters power and thrust build up times

Manoeuvring thrusters size in kW		Thrust load ramping times in Seconds			
>	<	A	B	C	D
0	250	2	4	6	8
250	700	4	8	12	16
700	1200	6	10	15	30
1200	1800	9	15	20	40
1800	2400	12	20	30	60
2400	3000	20	30	40	80
Approximately Thrust ramping kW/s		150	100	75	35

**Table 4, Proposed Thrust power build up time categorisation**

A Category A thrusters will in most configurations need to have more running machinery power than the actual max thruster power to be able to manage the high dynamic loads. Alternatively a stored energy source as a battery or an advanced flywheel solution could be installed to handle the dynamic variations

Thrusters in Category B/C follows more or less the curve as for a diesel engine for the same size and Category D thrusters have slower response and could be operated with less or slower running machinery.

The above explanation is only meant to illustrate the loading rates, the combination of thrusters and the applicable load case should be checked to find the resulting load rate curve and checked according to applicable modes as described later.

## Proposed Thrust Load Cases

The below load cases are meant as examples, actual load cases based on the actual vessel operation profile and requirements should be established.

Load Case	Thruster configuration and load changes
1	All propulsion power 0-100% (Extreme)
2	MP + side thrusters 0-67% (Manoeuvre Mode extreme)
3	MP 0-50% + Side thrusters 0-100 % (Manoeuvre mode 1)
4	MP 0-50% + 2 biggest Side thrusters 0-100 % (Manoeuvre mode 2)
5	50% - 100% of 1 MP + Largest side thrusters group from 50-100% (DP Fault)
6	...

**Table 5, Proposed Load Cases**

Based on the load cases the actual dynamic power builds up curve for your thruster configuration to be established. This curve should be used and compared to your power generation dynamic capabilities in various modes.

## Proposed main generator dynamic load capability classification Index.

The below table is based on study of engine manufacturers guidance for loading rates as well as class rules expectations and requirements, and is only a proposal.

The loading rates need to be seen in relationship with the operation profiles of the vessel i.e. how many dynamic loading variations of the main generators that are expected. This could have effect on the maintenance requirement for the engines as well as the related systems.

The table below is therefore divided into Emergency mode with only occasional load changes as crash stop scenarios etc. and manoeuvring mode where it is more normal with several load changes within a given time frame.

Engine loading rates or transient load capabilities index																
	Load Steps	Time to stable condition														
		A1	A2	B1	B2	B3	B4	C1	C2	C3	D1	D2	D3	D4		
		Time [s]	Time [s]	Time [s]	Time [s]	Time [s]	Time [s]	Time [s]	Time [s]	Time [s]	Time [s]	Time [s]	Time [s]	Time [s]		
EM MODE (diesel)	0-100%	5,0	5,0	10,0	15,0	20,0	20,0	20,0	20,0	20,0	20,0	20,0	30	30		
Only occasional	0-50%	3,0	3,0	5,0	7,5	10,0	10,0	10,0	10,0	10,0	10,0	10,0	15	15		
Load Changes	50-100%	3,0	3,0	5,0	7,5	10,0	10,0	10,0	10,0	10,0	10,0	10,0	15	15		
	0-33-66-100%	3,0	3,0	5,0	5,0	7,5	7,5	7,5	7,5	7,5	7,5	7,5	10	10		
MANOUEVER	0-100%	5,0	10,0	15,0	20,0	30,0	60,0	80,0	80,0	120,0	160,0	180,0	270,0	360,0		
MODE	0-50%	3,0	5,0	5,0	7,5	15,0	20,0	20,0	20,0	20,0	25,0	30,0	30,0	30,0		
Several Load Cases	50-100%	3,0	5,0	7,5	10,0	20,0	40,0	60,0	60,0	100,0	140,0	150,0	250,0	330,0		
in a 30 min period	0-33-66-100%	3,0	3,0	5,0	5,0	10,0	15,0	30,0	40,0	60,0	80,0	100,0	130,0	160,0		
		EM Gen		Typical generators for diesel electric propulsion												
		Diesel Engines														
		Dual Fuel Engines														
		GAS engines														
Typical Engine size		250-1500 kW				500-2000 kW				1500-6000 kW				5000-12000 kW		
Typical kW/s		250				200				60				30		
		Generators that possible should be support by accumulated energy source to cope with system the dynamic requirements														

**Table 6, Proposed Generator Loading merit index**

The table also indicate a very rough estimated expected power range for typical engines in the different categories as well as what size that is my understanding of normal engines used for generators today. It also indicates dual fuel (DF) engines that could automatically switch to diesel in case of dynamically “overloaded” and gas engines.

## PROPOSED EARLY DESIGN STAGE MODE EVALUATION SYSTEM

When you have selected your thruster configuration and the applicable load cases as well as understand the remaining vessels power demand in the various operation modes you might draw up the dynamic power demand curves for the various modes of operation or faults scenarios.

Depending on your requirements for separation and redundancy as well as the MSB and system configuration the dynamic power demand curves could be made for individual sections of the switchboard, or if you operate with closed bus ties you could evaluate this for your whole system.

By evaluating this in an early design phase you might configure modes and main power generating machinery configurations, as well as defining the need for power accumulator effects to be able to handle dynamic variations with as little running machinery as possible.

This method is a simple early stage approach but it still indicates the dynamic behaviours and relations to some extent.

# CONCLUSIONS

## Bridging the gap of traditional static design and modern time-domain simulations

This method will not replace any of the already established methods, as the static approach with a dynamic factor, or time-domain simulations. It is meant as a supplement to make the designer aware of the dynamic relations.

To use modern dynamic design and simulation tools, you will also have to understand various configurations and their limitations. You will have to make assumptions and simplifications at least at an early design stage. And such a basic system will also be beneficial for at least early design review with modern dynamic simulation tools.

I therefore believe that a similar approach as the one given above, where you make a categorisation of various equipment, could be a helpful for the industry. It could possibly be used as a basis for forming a future standard for categorisation standard for dynamic behaviour for main machinery.

## REFERENCES

- [40] Solevåg, Arne. 2016 "Ship response and manoeuvrability -Main machinery characteristics, configuration modes, and its resulting effect on thrust response. Proposed dynamic ship merit factor/index."
- [41] Børhaug, Brede. 2012 "Experimental validation of dynamic station keeping capability analysis: The next level DP capability analysis."
- [42] Smogeli Ø. 2006. Control of Marine Propellers. From Normal to Extreme Conditions. PhD thesis. NTNU.
- [43] Pivano L, 2008. Thrust Estimation and Control of Marine. Propellers in Four Quadrant Operations. PhD thesis. Faculty of Information Technology, NTNU.
- [44] DNV, DNV-RP-C205 - Recommended Practice for Environmental Conditions and Environmental Loads, April 2014.
- [45] DNV GL, ST-0111 – Standard for Assessment of station keeping capability of dynamic positioning vessels, July 2016.  
<https://rules.dnvgl.com/docs/pdf/DNVGL/ST/2016-07/DNVGL-ST-0111.pdf>
- [46] DNV GL Rules for Classification,  
[https://rules.dnvgl.com/ServiceDocuments/dnvgl/#!/industry/1/Maritime/1/DNV%20GL%20rules%20for%20classification:%20Ships%20\(RU-SHIP\)](https://rules.dnvgl.com/ServiceDocuments/dnvgl/#!/industry/1/Maritime/1/DNV%20GL%20rules%20for%20classification:%20Ships%20(RU-SHIP))