



Norwegian University of
Science and Technology

Interfacial dilation rheology properties of films formed at the oil/water interface by reaction between acid and calcium ion

Estefania Blanco Manotas

Chemical Engineering

Submission date: June 2017

Supervisor: Johan Sjöblom, IKP

Norwegian University of Science and Technology
Department of Chemical Engineering

1. INTRODUCTION.....	3
2. BIBLIOGRAPHY.....	4
2.1- CALCIUM NAPHTHENATE DEPOSIT.....	4
2.2-ARN OR TETRAMERIC ACID.....	4
2.3-STRUCTURE AND MODEL COMPOUND FOR ARN.....	4
2.4-FORMATION OF DEPOSITS.....	5
2.5- MODEL COMPOUND OF ARN.....	5
2.6- PHYSICOCHEMICAL PROPERTIES OF ARN.....	5
2.7-NAPHTHENIC ACID.....	6
2.8-ASPHALTENES.....	6
2.9-CALCIUM NAPHTHENATE GEL FORMATION.....	6
3. EXPERIMENTS AND METHODS.....	7
3.1-CHEMICAL PRODUCTS.....	7
3.1.1- SOLVENTS AND SALTS.....	7
3.1.2-ASPHALTENES SOLUTION.....	7
3.1.3-SOLUTIONS.....	8
3.1.3.1. <i>Organic solution</i>	8
3.1.3.2- <i>Aqueous solution</i>	9
3.2- TECHNIQUE.....	9
3.2.1- THEORY.....	9
3.2.1.1- <i>Interfacial Tension</i>	9
3.2.1.2- <i>Dilational interfacial rheology</i>	10
3.2.1.3- <i>The dilatational viscoelasticity</i>	11
3.2.2-SINTERFACE PAT-1M.....	12
3.2.2.1-COMPOSITION.....	14
3.2.2.2- <i>Calibration</i>	14
3.2.2.3- <i>Parameters</i>	15
3.2.2.4- <i>Oscillation for interfacial rheology</i>	16
3.2.3-COAXIAL CAPILLARY.....	16
4. RESULTS.....	18
4.1- KINETIC OF ADSORPTION.....	18
4.1.1- <i>Gelation of ARN as a function of pH</i>	19
4.1.2- <i>Transition with pH</i>	20
4.1.3- <i>Influence of parameters on transition</i>	21
4.1.4- <i>Conclusion gelation of ARN as a function of pH</i>	23
4.2-INTERACTION ARN/ASPHALTENES.....	24
4.2.1- <i>Asphaltenes alone</i>	24
4.2.2- <i>Interaction Asphaltenes/ ARN at different pH's</i>	25
4.2.3- <i>Interfacial tension as a function of time at different concentrations of Asphaltenes</i>	37
5.CONCLUSION.....	40
6.REFERENCES.....	41
7. APPENDIX.....	42

1. INTRODUCTION

The project is focus on the calcium naphthenate deposition, due to the calcium naphthenate gel which is formed at the interface of oil and water through a reaction between tetrameric acid and calcium ions.

There is a formation of Naphthenic acid so it is important to study because these components influence the stability of crude oil emulsions. Besides, the interfacial viscoelastic film is weakened when these components are present. It can be observed that it is a decrease of E' and E'' when the concentration of naphthenic acid increases. As a consequence, the naphthenic acid can impede the ARN/Ca^{2+} film formation.

During the experiments, it is going to be used a coaxial capillary following by Sinterface Profile Analysis Tensiometer (PAT-1m) which makes the dilatational, viscoelasticity analysis and interfacial measurements possible.

This technique allows to have an exchange in the oil sample drop, so a dynamic interface between oil and water must exist. The full process will be explained later.

It can be said that ARN forms a gel at interface if the pH is high enough in presence of calcium, so there are two parameters that are going to be studied:

1. Influence of pH
2. Influence of asphaltenes on the formation of a gel at interface

This project is a continuation of a last internship.

2. BIBLIOGRAPHY

2.1- Calcium naphthenate deposit

Calcium naphthenate deposition is the principal problem besides waxes, emulsions, gas hydrates and asphaltenes deposit because they influence the stability of crude oil emulsions. Until now, it has been acknowledged that the deposit was made up of calcium soaps, but recently it has been identified that the ARN acid is the dominating constituent of these deposits.

2.2-ARN or tetrameric acid

The ARN consists of 4-protic carboxylic acid with 4-8 unsaturated rings in the hydrocarbon skeleton and a molar mass from 1227 to 1235 g/mol. The most abundant molecule of ARN has an empirical formula $C_{80}H_{142}O_8$ and a molar mass of 1231 g/mol. The ARN was discovered by ConocoPhillips and Statoil.

After some studies, the initial reaction between ARN and Ca^{+2} is considered to take place. This reaction leads to the formation of gel at interface. This gel formation is important because it is considered the first step in the formation of the calcium naphthenate deposits.

2.3-Structure and Model Compound for ARN

The structure of ARN was resolved by Lutnaes et al, It is assumed that ARN comes from by Archaea micro-organism, whose growth determined the difference of abundance of the isomers with the origin of the oil.

This figure shows the formula of the most abundant C_{80} 6 rings tetrameric acid or ARN. [1]

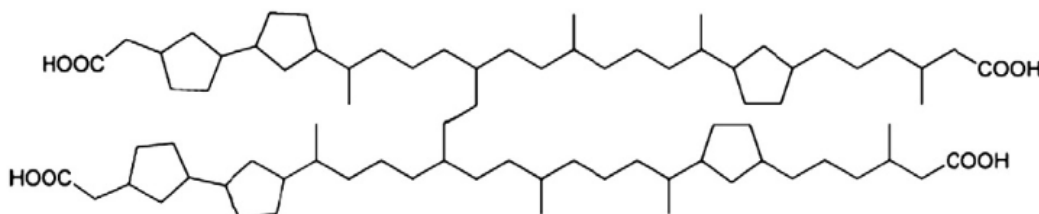

Figure 1: Formula of C_{80} ARN or tetrameric acid.

2.4-Formation of deposits

The presence of ARN is the prerequisite for the formation of calcium naphthenate deposits, but its existence does not necessarily imply deposition. ARN is present in low concentration in petroleum crude oil. Several aspects of the formation mechanism of calcium naphthenate deposits are known: During oil production, the pressure drops and CO₂ are released which induce a raise of the pH of the produced water phase. ARN's carboxylic acid functions are ionized and react with Ca²⁺ present in aqueous phase to form a cross-linked film at interface that will ultimately deposit. [1]

2.5- Model compound of ARN

On the other hand, there are some difficulties in the study focusing on ARN, this problem is the purity and the lack of chromophore, so UV visible is needed to simulate natural ARN.

For this reason, it is necessary to use a model of molecules close to the structure of ARN. These molecules are BP10 (benzophenone) and Pe10(perylene aromatic core) which are pure and easy to detect due to the presence of chromophore.

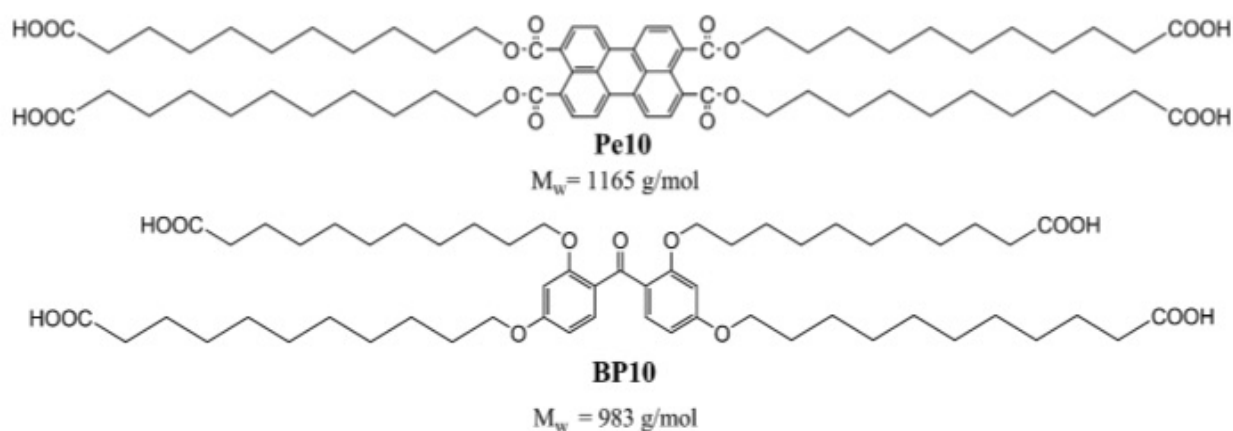

Figure 2: Structure of BP10 and Pe10, used as a model to imitate ARN.

2.6- Physicochemical properties of ARN

The tetrameric acids are highly interfacially active at oil-water interfaces, and display critical micelle concentrations(CMC's) in aqueous solutions. This is however not easily detected at neutral pH, due to the fact that the tetrameric acids in the undissociated form are insoluble in water. Increasing the pH will successively dissociate more acid groups, rendering the tetrameric acid increasingly water soluble.

[4]

As a surfactant, in terms of surface activity, interfacial tension decreases when the ARN's concentration increases. ARN will diffuse to the liquid-liquid or liquid-air interface and adsorb at the interface thus decreasing the interfacial tension. [2]

ARN forms preferentially oil-in-water emulsion at water cuts ranging from 10-90% in volume from pH 4 to 10. The emulsion is stabilized when pH increases most likely because of an increase in electrostatic repulsions between droplets due to the ionization of carboxylic acid functions. In this form, ARN is in ionized state. [2]

2.7-Naphthenic Acid

Naphthenic Acid (NA) is a mixture of cyclopentyl and cyclohexyl carboxylic acid. ARN is present in crude oil at very low concentrations, typically a few ppm when detected, this means at much low concentrations than the other naphthenic acid [1].

NA are important in the gel formation, because can inhibit the gel formation of tetrameric acid or BP-10. In addition are important components in crude oils because they influence the stability of crude oil emulsions. They react with calcium acting as terminating agent preventing the formation of gel.

2.8-Asphaltenes

Asphaltenes in crude oil are polar components. They are the oil part, insoluble in n-alkene and soluble in aromatic solvents, and furthermore they are a group of molecules that differed in molecular weights and functionalities.

On the other hand, asphaltenes is surface active and can absorb in the oil/water phase.

2.9-Calcium naphthenate gel formation.

When the ARN is put in contact with calcium containing water, there is a reaction when the pH is raised. Because of ionization of carboxylic groups and the reaction with calcium ions there is on the interface the formation of the gel. This occurs because they form a cross-linked structure.

3. Experiments and methods

3.1-Chemical Products

3.1.1- Solvents and salts

In the following table are going to show all the solvents that are used during all the experiments.

Chemical	Purity (%)	Provider
MOPS	99,5	Sigma Aldrich
BORAX	99	Sigma Aldrich
NaCl	99,5	Sigma Aldrich
Xylene	98	Sigma Aldrich
THF	99,9	Sigma Aldrich
MES	99	Sigma Aldrich

Table 1: List of solvents used in the experiments

3.1.2-Asphaltenes solution

The asphaltenes were extracted from the rest of the crude oil designated as maltenes, by precipitation in n-hexane. The crude oil was initially heated for at least one hour to solubilize wax precipitation etc, to 60 degrees and shaken to ensure homogeneity in the sample.

160 mL of n-hexane was added to 4 grams of crude oil sample and stirred overnight. The next day, the asphaltene fraction is retrieved from the maltenes, using a 0,45 μ m HVLP (milipore) membrane filter.

The rest of components are removed by washing with n-hexane. Finally, the asphaltenes are dried overnight in a dryer filled with nitrogen gas.

3.1.3-SOLUTIONS

3.1.3.1. Organic solution

1. ARN solution

ARN solution at 500 μ M can be obtained by dissolution of ARN fully protonated using xylene. Once the mixture is prepared, it is necessary to leave it stirred overnight in a shaker at 250 rpm. The day after, the solution is filtered using a 0.2 μ m PTFE filter. After that, the ARN solution is ready to be diluted with xylene and then obtain the concentration of ARN that is necessary.

2. Asphaltenes solution

Asphaltene solution (stock solution 1g/L) is prepared dissolving solid asphaltenes with xylene, then the mixture is put in a sonication bath for 30 min, and then in a shaker at 200 rpm overnight. The day after it is necessary to put in another sonication bath for 10 min, and then it is ready to be used after dilution to the desired concentration.

3. Mixture of ARN-Asphaltenes

To prepare the mixture of ARN-Asphaltenes, it is going to be needed to prepare two solutions, ARN at 500 μ M and Asphaltenes with a concentration of 1g/L. To obtain ARN at 500 μ M for the mixture, it is necessary to weigh 30 mg of ARN fully protonated and complete to 42.3g with xylene in a screw-capped tube, then the solution is stirred overnight. Next day the solution is filtered with 0.2 μ m PTFE filter.

On the other hand, for the asphaltene solution it is necessary to weigh 30 mg of asphaltene and complete to 26 g with xylene in a screw-capped tube. After, the solution is put in the sonication bath for 30 min, and then it is shaken at 200 rpm overnight. After that, it can be obtained a mixture of ARN-Asphaltenes at different concentrations of asphaltenes, it depends on how the solutions are mixed.

Concentration of Asphaltenes desired	ARN at 500 μ M	Asphaltene 1g/L	Xylene
0,05g/L	0,235 g	2,345 g	44,31 g
0,1g/L	0,235 g	4,69 g	41,96 g
0,4g/L	0,235 g	18,35 g	27,9
1g/L	0,118 g	23,32 g	-

Table 2: Concentrations to obtain each mixture with $[ARN]:2.5\mu M$ and different concentrations of Asphaltenes.

3.1.3.2- Aqueous solution

1. Calcium buffer solution

To prepare calcium buffer borax solution is necessary to mix two types of solutions buffer MES (pH 6), MOPS (pH 7) and Borax (pH 8 ,9 and 10) and calcium chloride solution using as solvent Mili-Q ultra-pure water.

Buffer solution is prepared dissolving MES, MOPS or BORAX and calcium chloride with Mili-Q water. After that, pH us going to be measured and it can be seen that the final solution is not obtained. Therefore, pH is adjusted introducing NaOH in the solution if the final pH is 6, 9 and 10 or with HCl is the pH desired is 8.

On the other hand, calcium chloride solution is acquired by dissolution of $\text{CaCl}_2 \cdot 2\text{H}_2\text{O}$ (Calcium chloride crystal) in Mili-Q pure water.

Once both solutions are mixed, it is obtained 20mM and 600Mm NaCl+10mM CaCl_2 +10mM buffer.

3.2- Technique

3.2.1- Theory

3.2.1.1- Interfacial Tension

IFT is the force per unit length existing at the interface between two immiscible liquid phases.

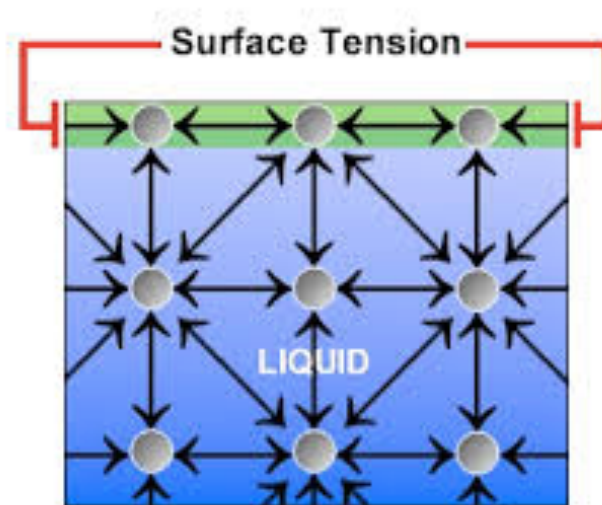

Figure 4: Example of Interfacial Tension

The sum of the interactions with the molecules of the same phase is greater than that of the interactions with molecules of the other phase. Molecules at the interface have fewer attractive interacting partners than in the volume phase. The phases therefore form the smallest possible interface without the action of external force. Work must be done to increase the size of the interface.

As with surface tension, differentiation is made between the static interfacial tension (measured in equilibrium with mechanically unchanged interface) and the dynamic interfacial tension (measured while the interface is changing). [3]

Definition of IFT:

$$dW = \gamma \cdot dA$$

Where,

γ : Interfacial tension (mJ/m²)

dA: Amount of area (m²)

dW: Amount of work (mJ)

There is another way to express the interfacial tension:

$$dW = F \cdot dx = 2 \cdot \gamma \cdot l \cdot dx$$

F: force (mN)

L and dx: dimension of distance (m)

γ : force exerted per unit length (mN/m)

3.2.1.2-Dilational interfacial rheology

Dilational interfacial rheology detailed the response of interfacial layers to expansions and compressions. Moreover, is important for systems that contain surfactants or more specific, for composite interfacial layers where the interfacial tension varies as a consequence of surface relaxation processes or diffusion.

For these systems a viscoelastic modulus, or dilational viscoelasticity, can be attributed to the interface characterizing, it is dynamic response to expansions/compressions [4].

In this case, it is based on the oscillation drop/bubble method. In this method, harmonic variations of the interfacial area can be used for dilational rheology and will be explained later.

3.2.1.3-The dilatational viscoelasticity

The dilatational viscoelasticity or also called complex viscoelastic modulus is used to express the relationship between surface modification of an interfacial layer and the related dilatational stress.

A general expression for the dilatational viscoelasticity can be [4]:

$$\Delta\gamma = E_0 \cdot \alpha + \eta \cdot \dot{\alpha} \quad (1)$$

E_0 is the dilatational surface elasticity, η is the viscosity, α is the surface stress and $\dot{\alpha}$ is the rate of surface deformation.

This equation leads to a definition of the complex dilatational viscoelastic modulus, or the dilatational viscoelasticity, E . For a low amplitude harmonic perturbation of frequency ν , in fact, the area perturbation can be expressed as $\Delta A = \tilde{A}e^{i2\pi\nu t}$ which, introduced in equation (1), gives:

$$E = \frac{\Delta\gamma}{\Delta A/A_0} = E_0 + i2\pi\nu\eta \quad (2)$$

The dilatational viscoelasticity E is then a frequency dependent complex quantifies, where the real part E_R is E_0 is the dilatational elasticity and $E_I=2\pi\nu\eta$ is the imaginary part which is directly related to the dilatational viscosity.

It is necessary to keep in mind that any change in the area on the interface due to low amplitude perturbation, can be expressed as superposition of harmonic components in the domain of frequency, according to Fourier formalism.

The response of the interfacial tension to an arbitrary area variation of the adsorbed layer is given by:

$$\Delta\gamma(t) = \int_0^t \hat{E}(\tau) \cdot \alpha(t - \tau) \cdot d\tau \quad (3)$$

Where \hat{E} is the inverse Fourier transform of E . It can be seen that the viscoelastic modulus is a transfer function of the interfacial layer.

To investigate the dynamic behaviour of the adsorbed layers, it is necessary to use Drop/bubble tensiometers, following the oscillating drop/bubble methodology and then, the viscoelasticity versus frequency can be measured.

According with this method, harmonic oscillation of the drop or bubble surface area result in periodic compressions and expansions of the adsorption layer at the interface. Any small amplitude harmonic perturbations on the surface area are related to equation [2] and [3]. [4]

The frequency sweep to the surface area using drop/bubble methodology can be obtained using this equation:

$$A = A_0 + \tilde{A} \cdot \sin(2\pi\omega t) \quad (4)$$

Where A^0 is the reference surface area and \tilde{A} the amplitude of the area oscillations.

On the other hand, the harmonic response of the surface tension:

$$\gamma = \gamma^0 + \tilde{\gamma} \sin(\pi\nu t + \phi)$$

Where γ^0 is the equilibrium reference surface tension and $\tilde{\gamma}$ the amplitude of the surface tension oscillations.

ϕ phase shift between the area perturbation and the response of the interfacial tension, is the phase of the complex dilational modulus.

In fact, according with the equation 2:

$$E(\omega) = \frac{\tilde{\gamma}}{\tilde{A}/A_0} \exp(i\phi) \quad (5)$$

This equation provides an expression for E terms of quantities that can be determined experimentally as frequency functions. [4].

Dilatational viscous modulus(E') and dilatational viscous modulus (E'') can be defined, but it is going to be explained later.

3.2.2-Sinterface PAT-1M

Sinterface PAT-1M is an instrument that can be used to measure the surface and the interfacial tension of liquids. In this project, it can be studied the interface of water phase including calcium ions and oil phase containing ARN, Asphaltenes or a mixture of ARN and Asphaltenes. It is a Drop and Bubble Shape Tensiometer and allows measuring:

- The surface and interfacial tension of liquids by the analysis of the shape of pendant and drop.
- The surface and interfacial tension as a function of time, so the kinetic of adsorption of surfactants at the liquid/air or liquid/liquid interfaces can be studied.

- The rheological properties of the interface (elasticity and viscosity) by subjecting the drop to periodic oscillation of their volume and measuring the induced variations of surface/interface tensions.

There is a relation at each point of the surface drop/bubble between Laplace pressure difference, the interfacial tension and the surface curvature due to Gauss Laplace equation as can be seen:

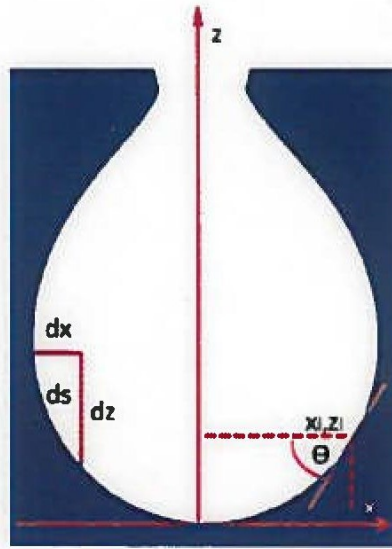

Figure 5: Example of the shape from digital images analysed using Gauss Laplace equation (picture took from manual Sinterface PAT-1M)

Gauss Laplace Equation:

$$\frac{dx}{ds} = \cos\theta \quad (6)$$

$$\frac{dz}{ds} = \sin\theta \quad (7)$$

$$\frac{d\theta}{ds} = \frac{2}{R_0} - \frac{\Delta\rho g z}{\gamma} - \frac{\sin\theta}{x} \quad (8)$$

Where,

s: arc length (m)

x: horizontal coordinate

z: vertical coordinate

R_0 : curvature radius from the drop apex (m)

g: acceleration of gravity (m/s^2)

θ : angle of the tangent to the profile

$\Delta\rho$: density difference (kg/m^3)

it is necessary to know the density (water and oil phase) to study the evolution of interfacial tension.

3.2.2.1-COMPOSITION

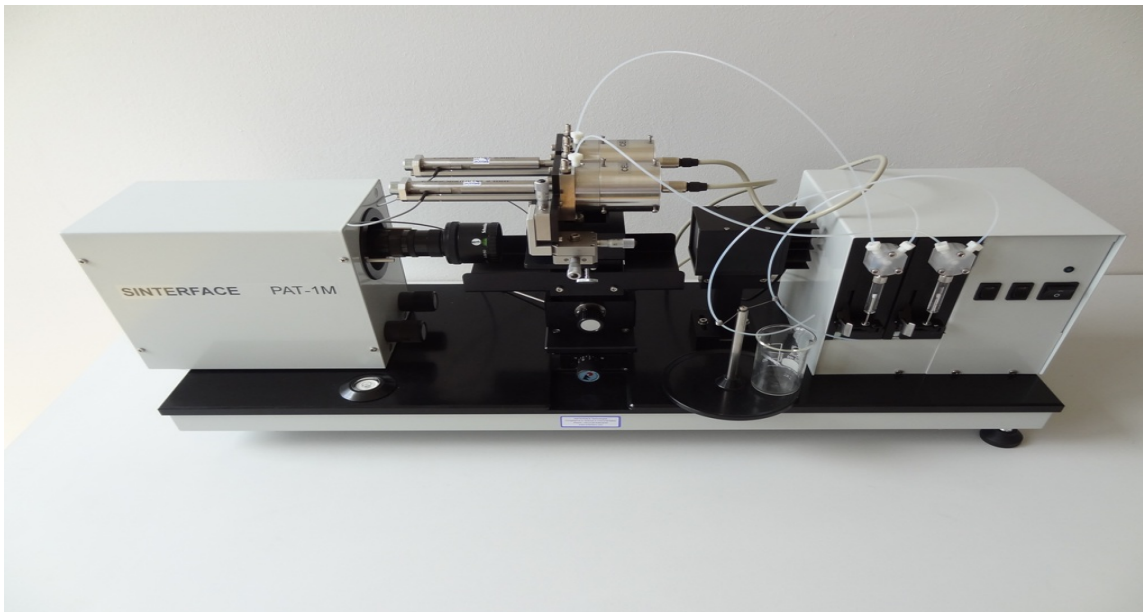

Figure 6: Photo of composition of Sinterface PAT-1M used during the experiments.

The photo shows the PAT-1M as it designed by Sinterface. All main parts are visible:

- The CCD camera with objective on the left
- Dosing system on the right
- High performance frame grabber installed in the PC
- Cold back lighting with continuously adjustable intensity.

There are also two chambers. One chamber consists of one capillary tube connecting sample to microsyringe, one microsyringe, one 3-way valve and one capillary tube relating 3-way valve to glass cuvette in the cell. [5],[6]

3.2.2.2- Calibration

Calibration is needed and is done with a solid sphere ($D=3.0$ mm, 4 or 5), in this case it is used a sphere of 3.0 mm.

It is necessary to have a clear image of the sphere, so focal plan of camera is adjusted moving the camera. Once, it is done, calibration button is clicked. The interruption is defined according to position showed in the manual.

3.2.2.3- Parameters

The list of different parameters for the experiment using PAT-1m, are taking from the last report. [6]

- Configuration of drop/bubble: Depending on the 2 densities of liquids to be studied, one can choose between pendant drop, emerging bubble, buoyant drop or sessile drop which make it feasible to create a drop/bubble surrounded by another liquid.
- Density of both liquid put in contact; internal density, ρ_{int} corresponding to the density of fluid inside the drop and external density, ρ_{ext} referring to the density of fluid outside the drop.
- $t_{TOT, EXP}$: total duration of one whole experiment (3200s).
- Volume of drop, V_D : Volume of the drop to be kept constant. In our case, $V_D=15\mu L$.
- t_{osc} : Time when the harmonic oscillation for interfacial rheology study begins (1200s).
- Since dilatational viscoelasticity is very sensible to the frequency of oscillation due to it is dynamic relation with interfacial layer, frequency sweep has been conducted to determine elastic and viscous term of the interface at different frequencies.

5 oscillations at a low amplitude of 3.5% have been set for each of these frequencies; 0.01, 0.0125, 0.025 and 0.05 Hz (correspond to period of 100, 80, 60,40 and 20 s respectively).

For the experiment of dynamic interface with continuous flow using coaxial capillary, supplementary parameters and terms have been used. In order to always keep the drop's volume constant (15 μ l), there will be an input and output into and from the drop through the inner and outer coaxial capillary. This is called exchange, therefore exchange parameters are:

- ΔV : The augmentation in volume from its initial value (1 mm³)
- Δt : The time taken from a drop's initial volume to expand to ($V_d+\Delta V$)'s volume before being pumped out back to return to the initial volume. (7seconds)
- Q: Flow rate. It is hence the ratio of ΔV over Δt .

- $V_{TOT, EXC}$: Total volume of liquid to be added through the entire exchange process's period. This parameter varies with the chosen exchange time and exchange flow rate Q . (103 mm^3)
- t_{exc} : The time exchange. It corresponds to the total time needed for an entire exchange process to settle.
- $t_{exc} = V_{TOT, EXC}/Q$.

3.2.2.4-Oscillation for interfacial rheology

Two parameters for dilatational viscous modulus can be showed as it is said before, so E' and E'' are defined as:

$$E'(\omega) = E^*(\omega) \cdot \cos(\varphi)$$

$$E''(\omega) = E^*(\omega) \cdot \sin(\varphi)$$

Where E' is the apparent elastic dilatational modulus and E'' the apparent viscous dilatational modulus, so it can be seen that the elasticity and the viscosity of the system is going to be studied. [Appendix, results \$E'\$ and \$E''\$](#) .

Procedure

3.2.3-Coaxial Capillary

In this project, coaxial capillary is going to be used to have an exchange in the oil sample drop. This system is continuous due to the volume of the drop must be kept constant, so there will be an intake and outtake from and to drop.

It is an exchange process, therefore, a dynamic interface between oil and water phase must exist.

The objective of this experiment is copy the adsorption of surface active at the interface under flow condition.

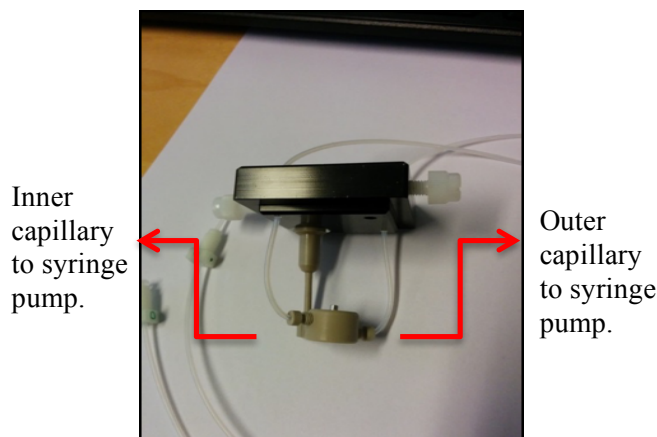

Figure 7: Representation of an exchange process with an oil phase sample drop, necessary to keep the volume constant.

In this experiment, coaxial capillary is needed to have a flow of ARN inside the oil droplet. The oil drop is made in a medium containing Ca^{2+} at different pH's.

The lower capillary tube is inlet tube and it is connected to the inner capillary of the coaxial capillary. New oil phase sample is introduced into the oil drop via inner capillary using a second syringe. On the other hand, the second capillary tube is called outlet tube and it is connected to outer capillary.

The oil phase is pumped out at the same time from the drop through outer capillary by first syringe to keep the volume of the drop constant.

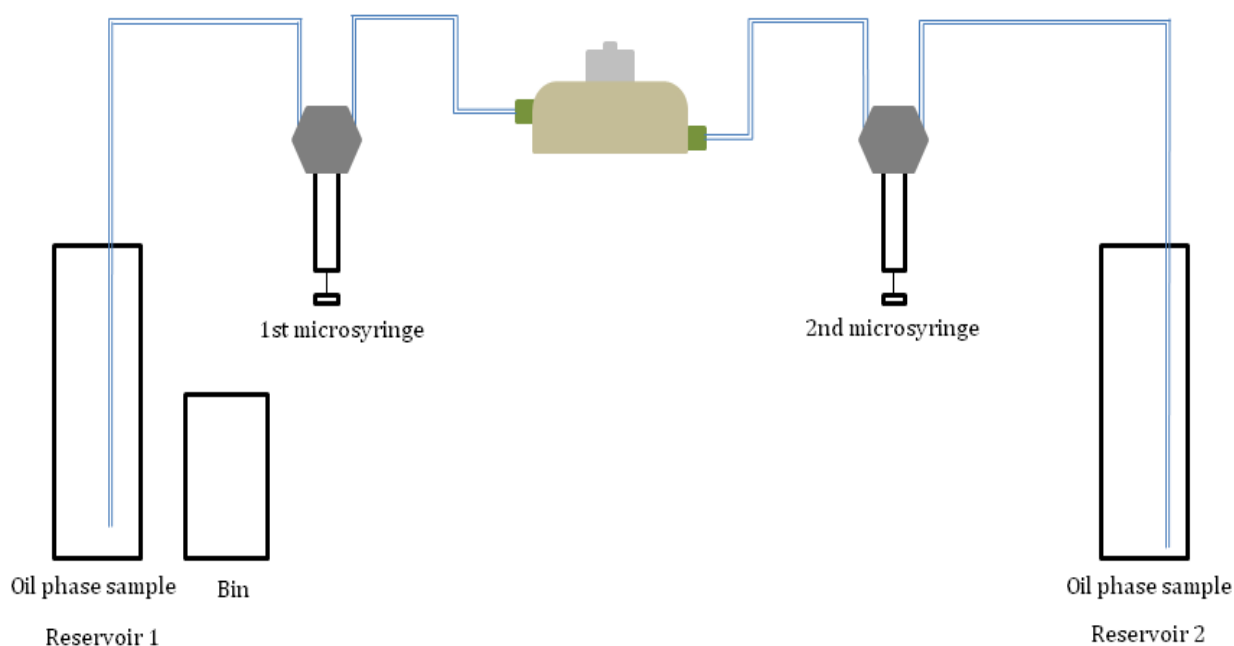

Figure 8: Principal process using coaxial capillary (Image took from presentation).

In the figure, it can be seen there are two tubes, which must be cleaned with oil phase samples from 1 to 2. After the cleaning process, it is necessary to take care if there is air bubble inside the tubes. Following this, the capillary tube is introduced in the cuvette where the calcium buffer solution is found. The cuvette contains 20mL of buffer solution. As it was said before, the volume of the drop must be kept constant and the value is $15\mu\text{L}$.

Now, it is time to start-up the experiment and it is necessary that the capillary tube from the reservoir 1 is shifted to the bin because it is going to be used to absorb oil phase from oil droplet during the process using the first microsyringe.

The interfacial torsion with time is measured with a flow rate of $0.143\mu\text{L/s}$ during 720s, after that oscillations are required at different periods 100, 80, 60, 40, 20s.

The oscillations are going to start at 1200s, so from 720 to 1200 is the relaxation time after the exchange process has finished.

4. Results

Goal:

Determining the influence of pH on the formation of gel at interface by:

- I. ARN alone
- II. Interaction ARN/asphaltenes

4.1- Kinetic of adsorption

The figure below represents the different interfacial tension evolution from the experiment using coaxial capillary and under flow condition at different pH's, with a concentration of ARN and NaCl, $2.5\mu\text{M}$ and 20mM respectively.

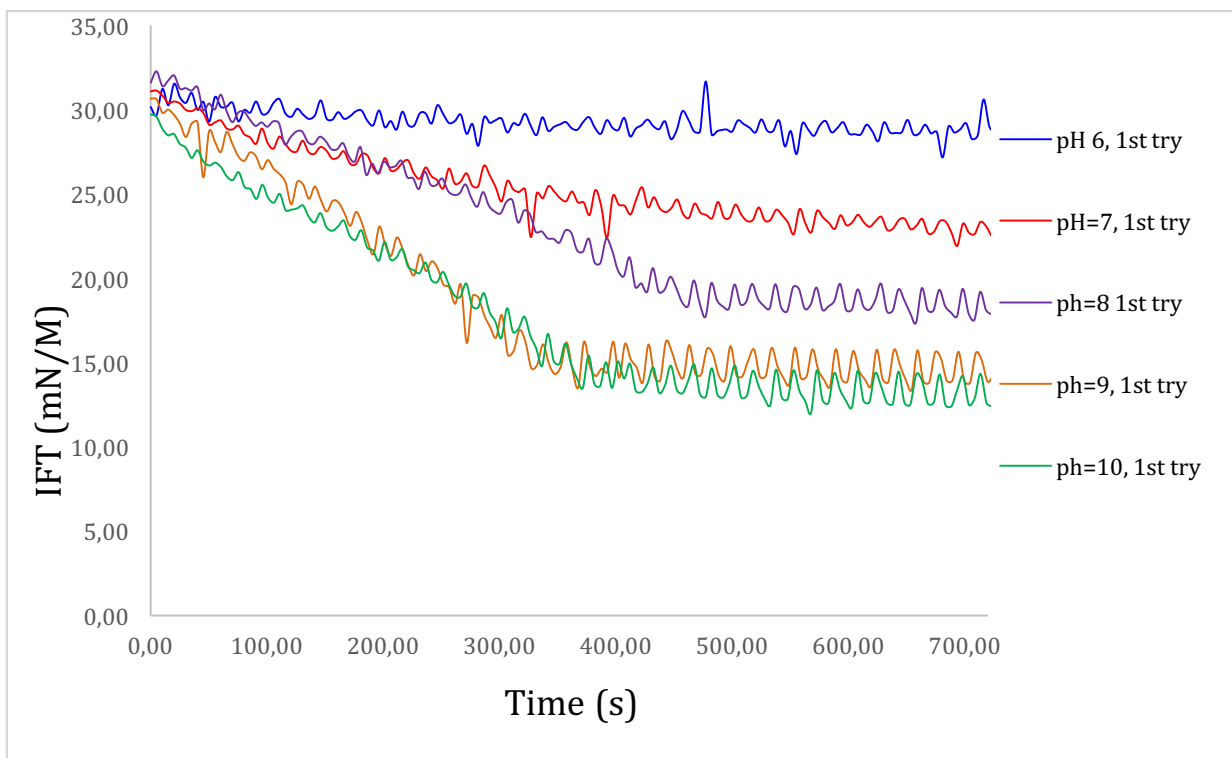

Figure 9: Interfacial tension against pH, with $[\text{ARN}]$: $2.5\mu\text{M}$ and $[\text{NaCl}]$: 20mM

As we can see in the [Figure 9](#), interfacial tension decreases when pH increases. At pH 6 there is not since IFT stay constant and is high, but from pH 6 to 9 an increase of the adsorption is found due to there are more molecules at interface to react with.

In addition, it can be seen that from pH 9 the adsorption on the interface is constant.

In the appendix, it is going to be find the figure with first and second try, but now is showed first try because is easier to see the evolution of IFT through each pH.

4.1.1- Gelation of ARN as a function of pH

To explain the formation of gel, a graph is required. It is going to be represented the viscoelastic moduli at two frequencies as a function of pH.

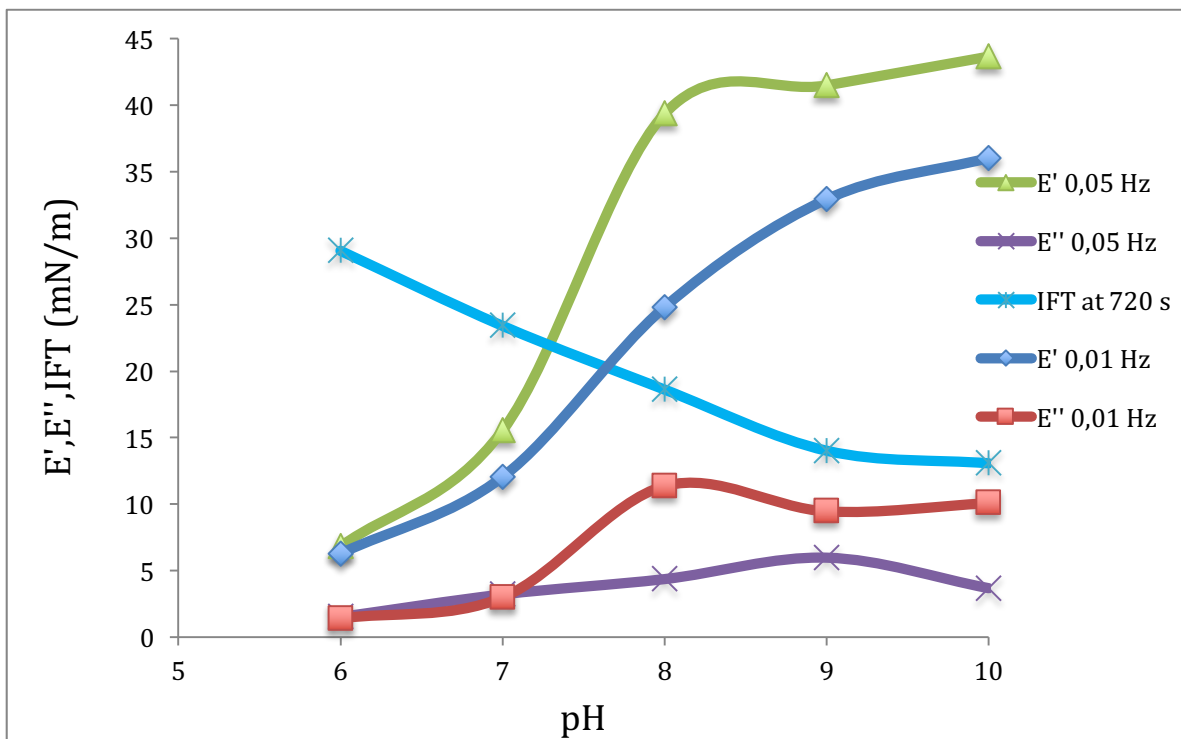

Figure 10: The graph of complex viscoelastic moduli for different pH's, for the formation of gel at two frequencies. [20mM]

The figure 10 shows the plot of viscoelastic moduli as a function of pH at different frequencies. It can be seen that there is an increase of E' at 0,05 Hz from pH 6 to pH10, but from pH 7 to 8, there is a sharp increase of viscoelastic moduli, so it can be said that due to interfacial rheology can be detected the formation of gel from pH 7 to 8.

4.1.2- Transition with pH

The following graph represents the transition of the parameters with pH for the different experiments changing the concentration of ARN.

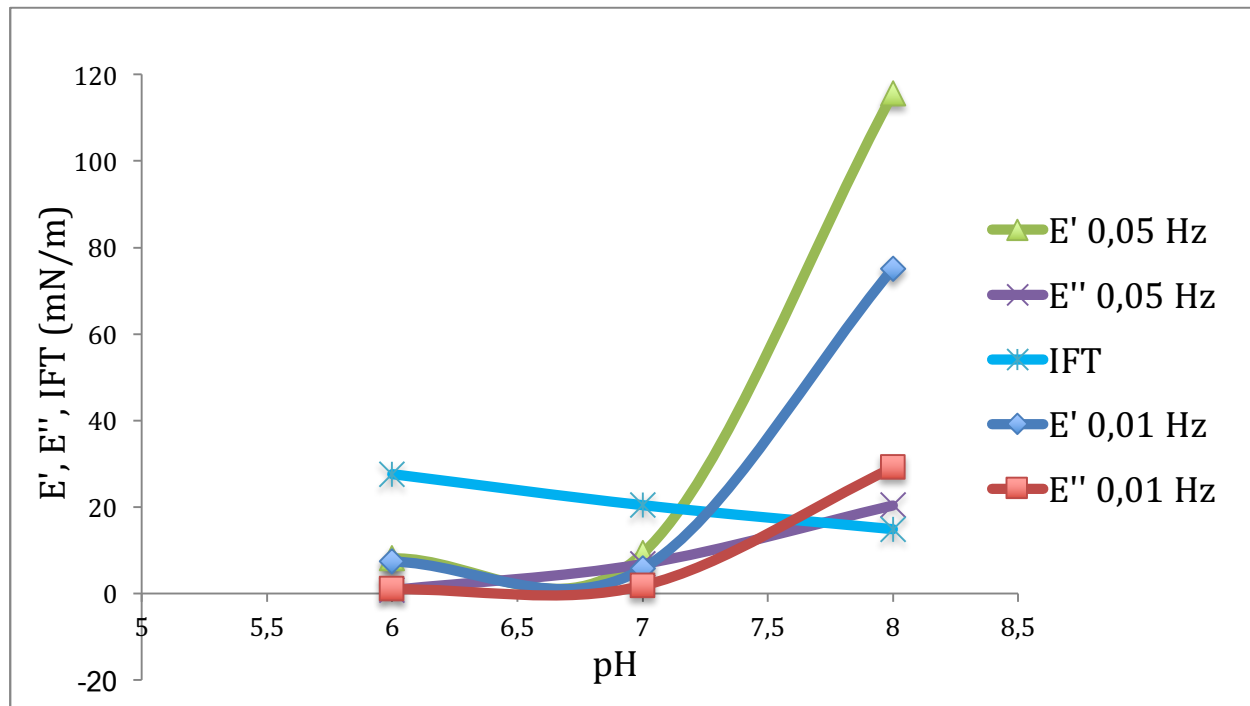

Figure 11: E' , E'' and IFT as a function of pH, with $[ARN]: 7.5\mu M$ and $[NaCl]: 600mM$

It is analysed figure 11 with previous graph 10, so in figures 10 and 11, we can analyse the transition with pH, using $[NaCl]: 20mM$ and different concentrations of ARN.

At $7.5\mu M$, we have only analysed pH's from 6 to 8, but it is sufficient to could analyse and compare with $2.5\mu M$.

In addition, we have an augmentation of dilatational moduli when pH increases in both graphs because of increase of ARN concentration.

On the other hand, when we look at the figure 11 it can be seen that when $[ARN]$ concentration increases the transition of this experiment has a similar evolution as figure 10, so the influence of ARN is weak when the concentration increases.

It might be explained, as, even if we change ARN concentration if there is not exist any change in NaCl concentration, the evolution of the experiment is similar in both concentrations.

4.1.3- Influence of parameters on transition

1. $[ARN]: 2.5\mu M$ and $[NaCl]: 20\text{ mM}$ and 600 mM .

As we saw before, the transition of the experiment with a unique concentration of NaCl and two different concentrations of ARN is quite similar, so now we are going to compare for each concentration of NaCl, what happen if the concentration of ARN is changed.

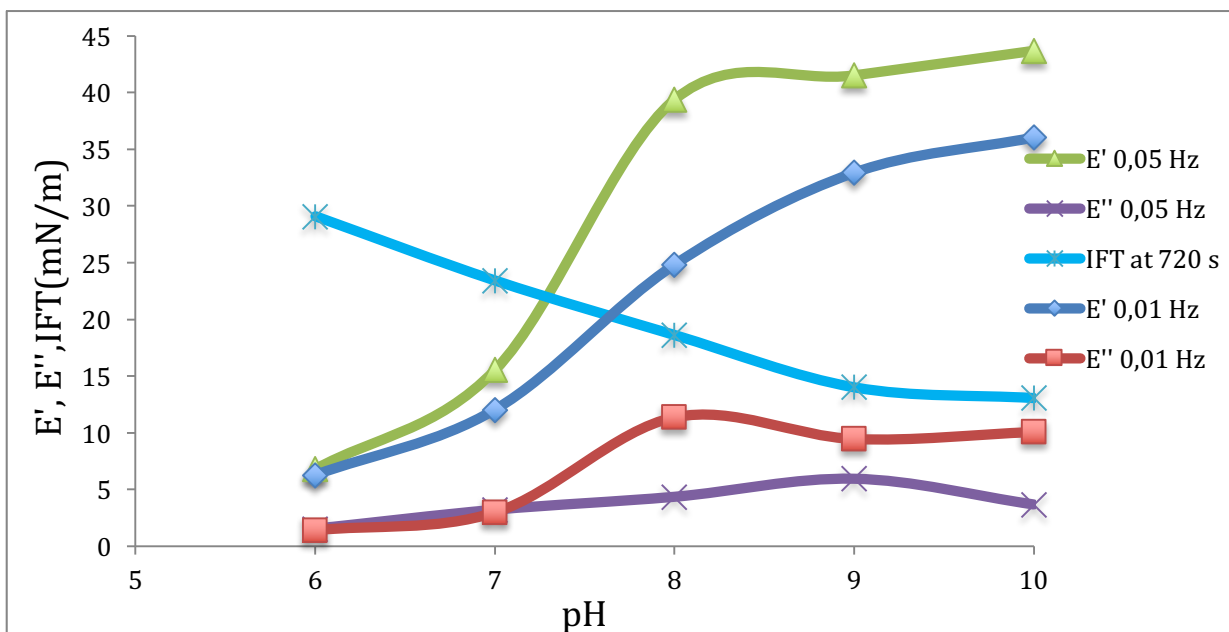

Figure 12: E' , E'' and IFT as a function of pH, with $[ARN]: 2.5\mu M$ and $[NaCl]: 20\text{ mM}$

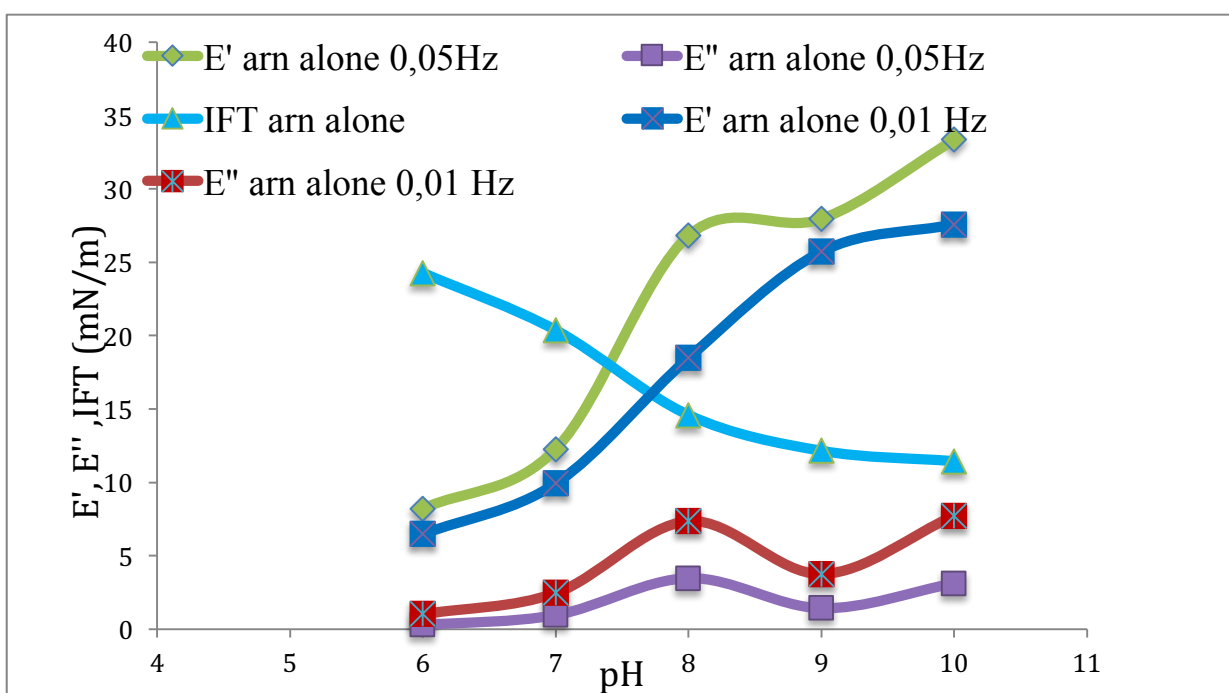

Figure 13: E' , E'' and IFT as a function of pH, with $[ARN]: 2.5\mu M$ and $[NaCl]: 600\text{ mM}$.

In the last figures 12 and 13, with NaCl solutions of 20mM and 600mM using a unique ARN concentration, it can be seen that E' increases when pH increases in both graphs.

If we focus on figure 13, at pH 8, 9 and 10 the E' is lower when the concentration of NaCl is 600mM instead of 20 mM, so there is weaker structure at higher ionic strength.

There is a weaker structure at pH 8 in presence of 600mM of NaCl.

2. $[ARN]: 7.5\mu M$ and $[NaCl]: 20$ and 600 mM

After explaining the influence of NaCl when the concentration of ARN is $2.5\mu M$, we are going to do the same but when the concentration of ARN is kept with a value of $7.5\mu M$.

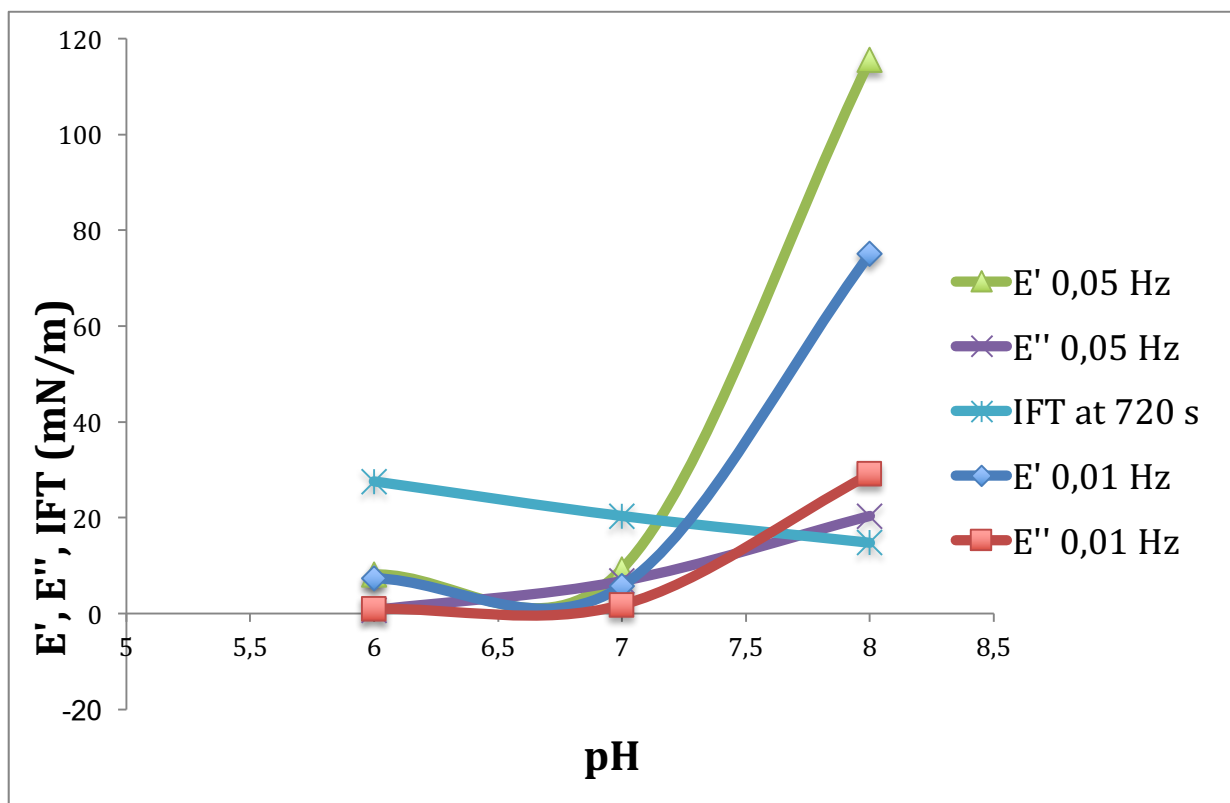

Figure 14: E' , E'' and IFT as a function of pH, with $[ARN]: 7.5\mu M$ and $[NaCl]: 20mM$.

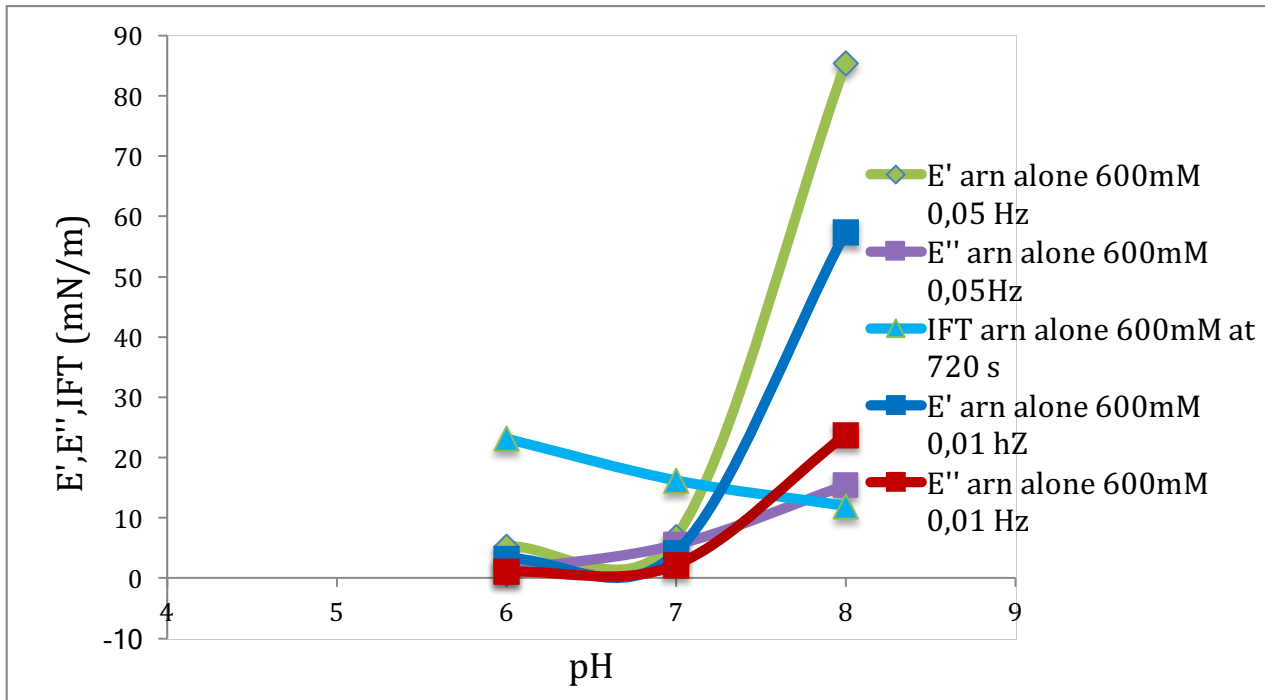

Figure 15: E' , E'' and IFT as a function of pH, with $[ARN]: 7.5\mu M$ and $[NaCl]: 600mM$.

In these two plots, it is showed the viscoelastic and dilatational modulus as a function of pH. We can compare from pH 6 to 8, and it is enough to see the differences.

In this case the concentration of ARN is $7.5\mu M$, but it can be seen that the behaviour in both graphs is quite similar.

There is a difference of 30 mN/m in the value of E' at 0,05 Hz when the concentration of NaCl is 600mM compared with 20 mM that is showed in [figure 14](#).

Thus, we have an influence of salinity, so there is a weaker structure at pH 8 when the concentration of NaCl is 600mM.

4.1.4- Conclusion gelation of ARN as a function of pH

To sum up, it can be said that the gelation of ARN is detected between pH 7 and 8 when interfacial rheology is used.

On the other hand, there is a weak influence of $[ARN]$ (2.5 VS $7.5\mu M$) and $[NaCl]$ (20 vs 600mM) on the transition.

Furthermore, a weaker structure is observed at higher NaCl concentration.

4.2-Interaction ARN/Asphaltenes

Before starting with the mixture ARN+Asphaltenes, it is necessary to know more about the behaviour of Asphaltenes alone when it is in contact with different pH's. After that, we can study the interaction of ARN and Asphaltenes on the interface oil/water.

4.2.1-Asphaltenes alone

To study the behaviour of Asphaltenes, it is going to be used a solution of 0.4g/L which it is prepared and mixed with xylene like it said in 3.2.

Therefore, the graph below shows the kinetic of adsorption of Asphaltenes at liquid/liquid interface with [NaCl]: 20mM

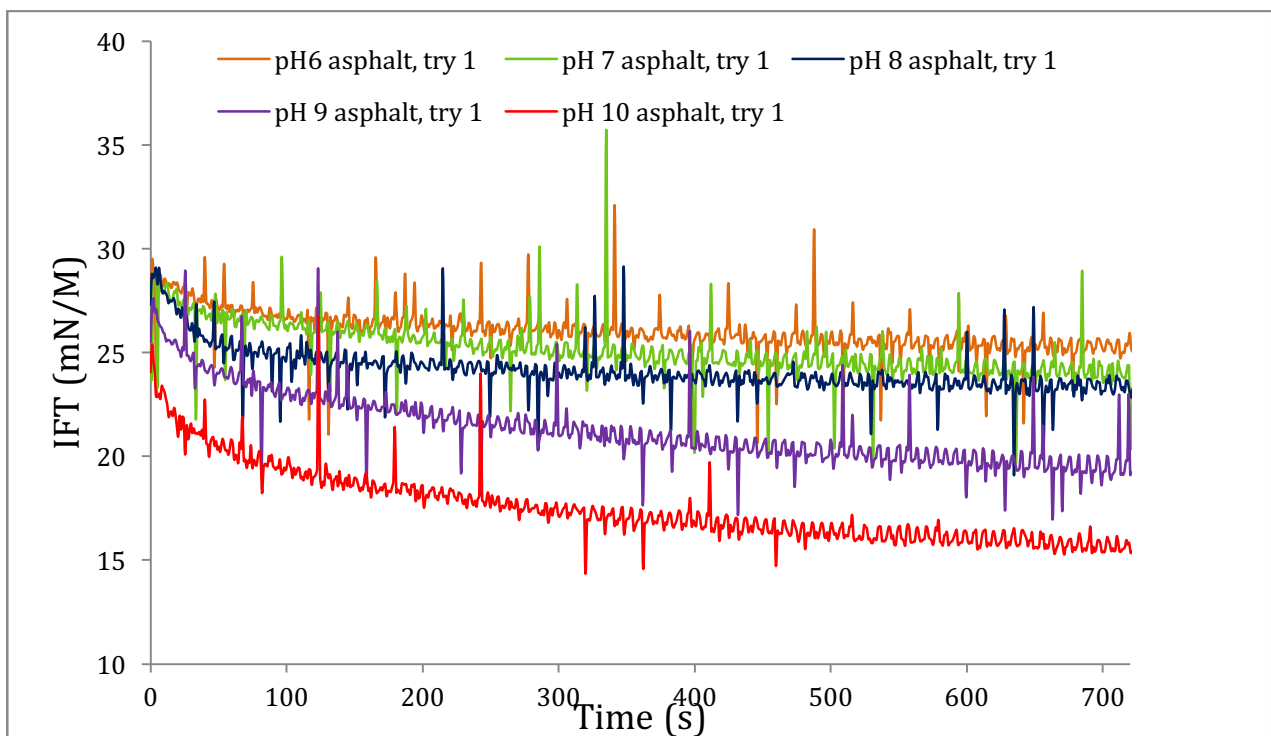

Figure 16: Kinetic of adsorption of asphaltenes at liquid/liquid interface. [NaCl]:20mM and [Asph]:0.4g/L

This figure 16 shows a plot that represent the interfacial tension against time. It can be seen that from pH 6 to 8 there is not decrease of the interfacial tension, but it exists a decrease of the interfacial tension from pH 8 to 10 because of the ionization of acidic asphaltenes.

The next graph is a representation of viscoelastic and dilatational moduli as a function of pH, when the solution is pure asphaltene.

The rest of the results and the second try are found in the appendix.

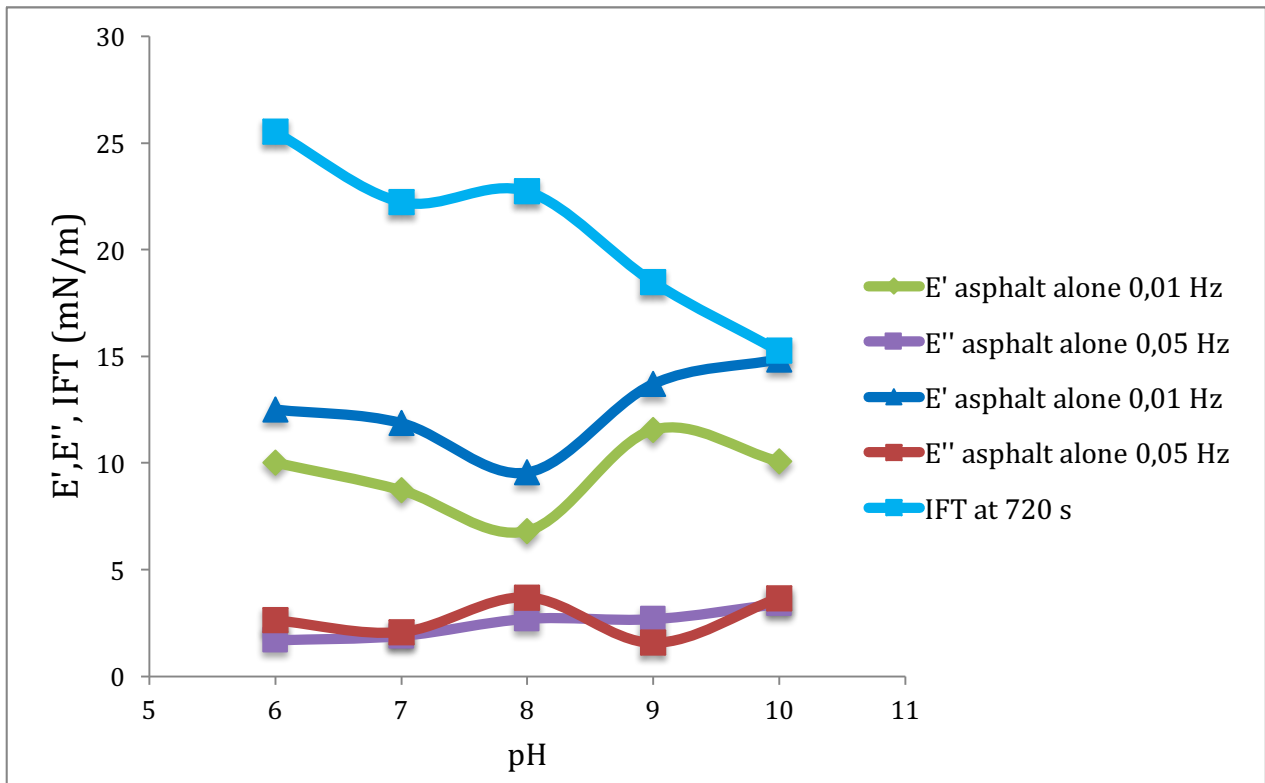

Figure 17: E' , E'' and IFT as a function of time, with pure asphaltene solution $[Asph]=0.4g/L$ and $[NaCl]=20mM$.

As we can see, there is a small decrease of E' with the pH due to the ionization of the acidic asphaltenes. Consequently, the basic properties of the asphaltenes do make an impact on the interface.

4.2.2- Interaction Asphaltenes/ ARN at different pH's

After knowing more about the asphaltenes behaviour, now we are going to see what happen when asphaltenes and ARN are mixed using different pH's, with a concentration of NaCl, asphaltenes and ARN of 20mM, 0.4 g/L and 2.5 μM respectively.

4.2.2.1-Interaction Asphaltenes and ARN at pH 6

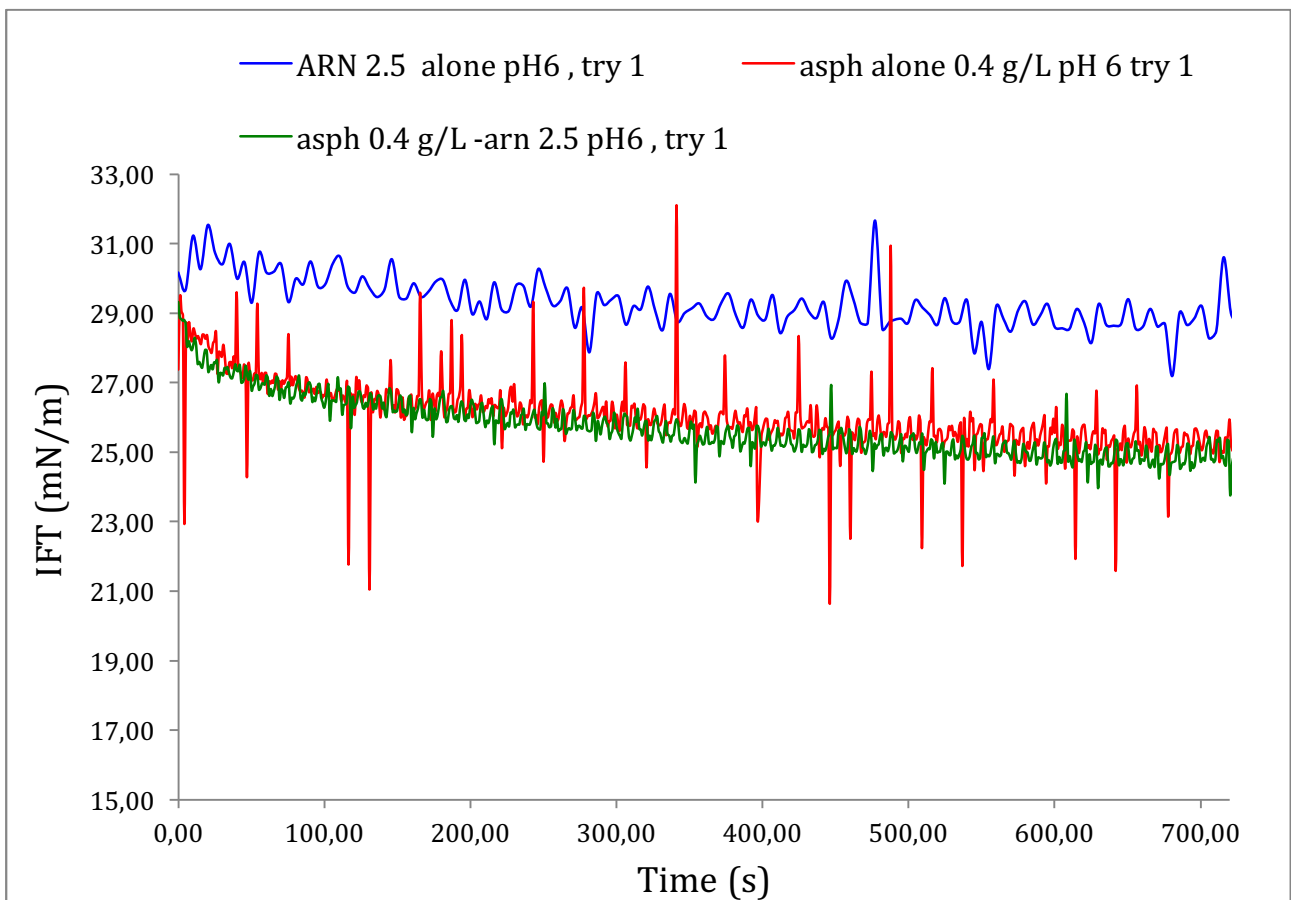

Figure 18: IFT as a function of time, until 720s when asphaltenes and ARN are mixed. $[NaCl]:20\text{ mM}$, $[ARN]:2.5\mu\text{M}$, $[Asph]:0.4\text{g/L}$.

In this [figure 18](#), we can observe that the lines of pure asphaltene are closer to the mix of asphaltene + ARN than pure ARN, so it seems that the interface is fully covered by asphaltenes.

To be sure about this, we have another graph below which represents dilatational and viscoelastic moduli for ARN alone, asphaltene alone and the mix.

The results and the second try are in the appendix.

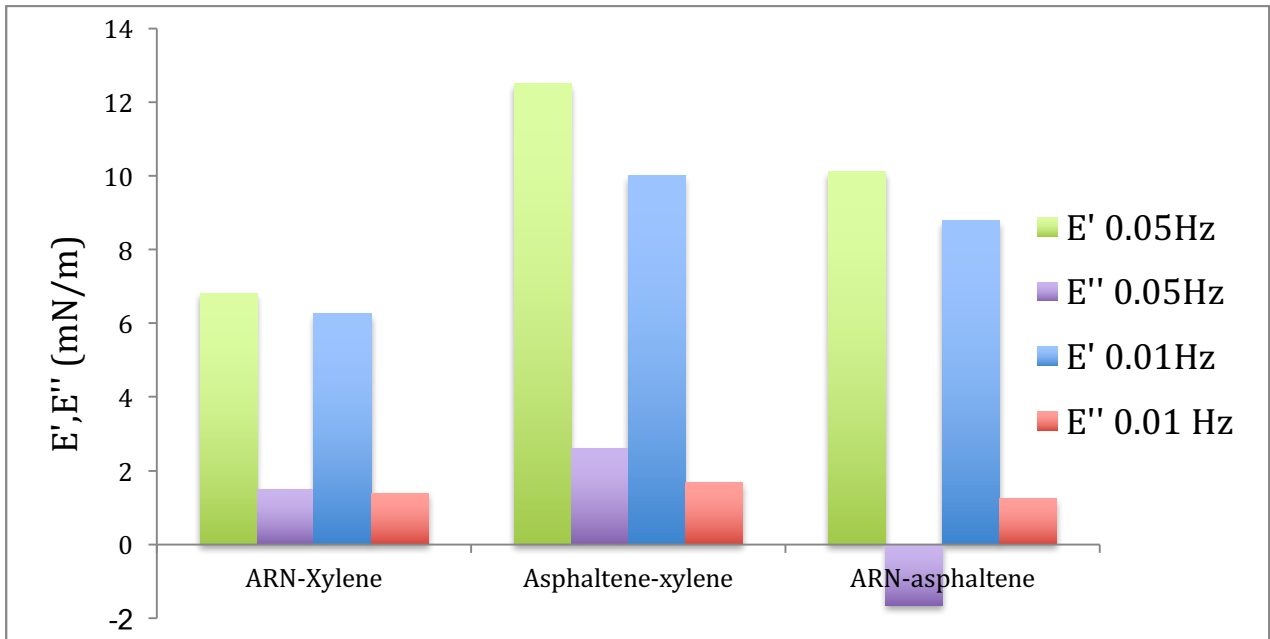

Figure 19: E' and E'' for different solution at two frequencies.

As we can see in the [figure 19](#), when we focus on E' at 0,05 Hz for asphaltene alone and asphaltene + ARN, the E' for this first one is only two mN/m more than the mixture, so is quite similar in comparison of pure xylene which is smaller.

We can say that the interface is covered by asphaltenes.

4.2.2.2- Interaction Asphaltenes and ARN at pH 7

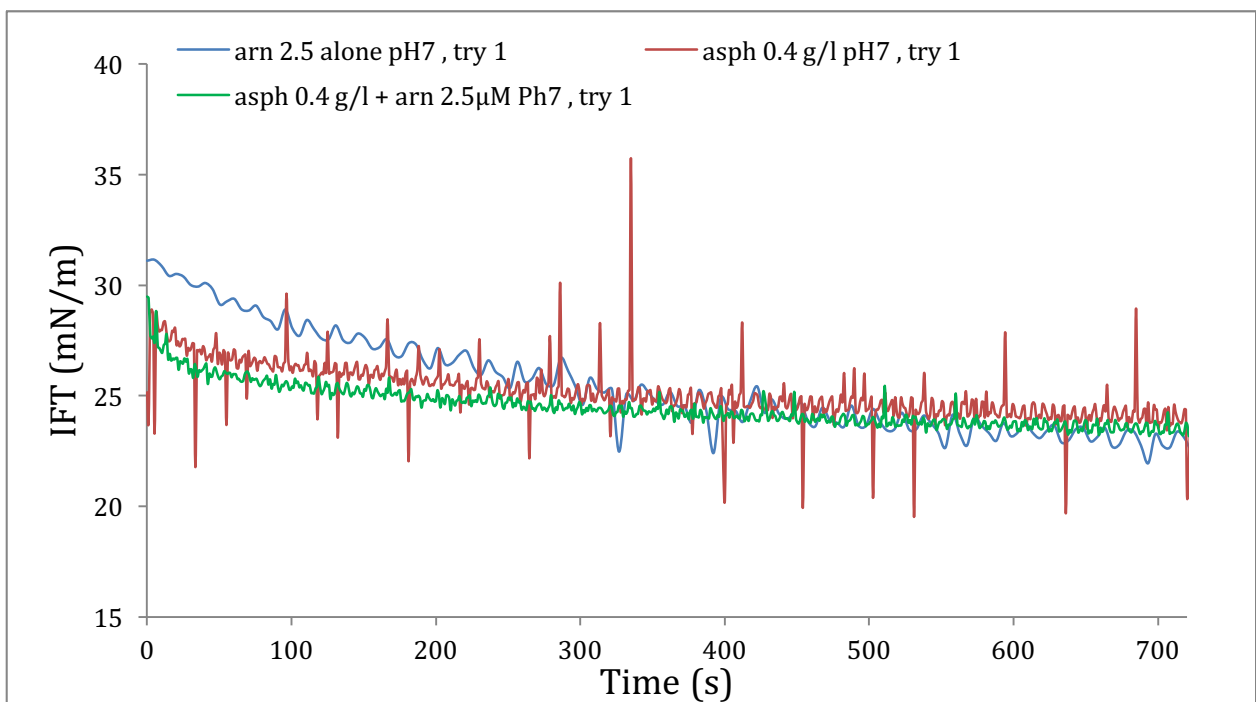

Figure 20: IFT against time for the interaction between ARN and Asphaltenes at pH 7

If we look at the lines of pure asphaltene and then the line of asphaltenes + ARN are closer again. In addition, the line of ARN alone is quite similar so in this case it is not too easy to see than before.

Therefore, if we only keep in mind the figure we can not state with certainty. The whole figure is showed in the appendix.

Thus, it is necessary to focus on the graph below, where it is compared E' and E'' for each type of solution.

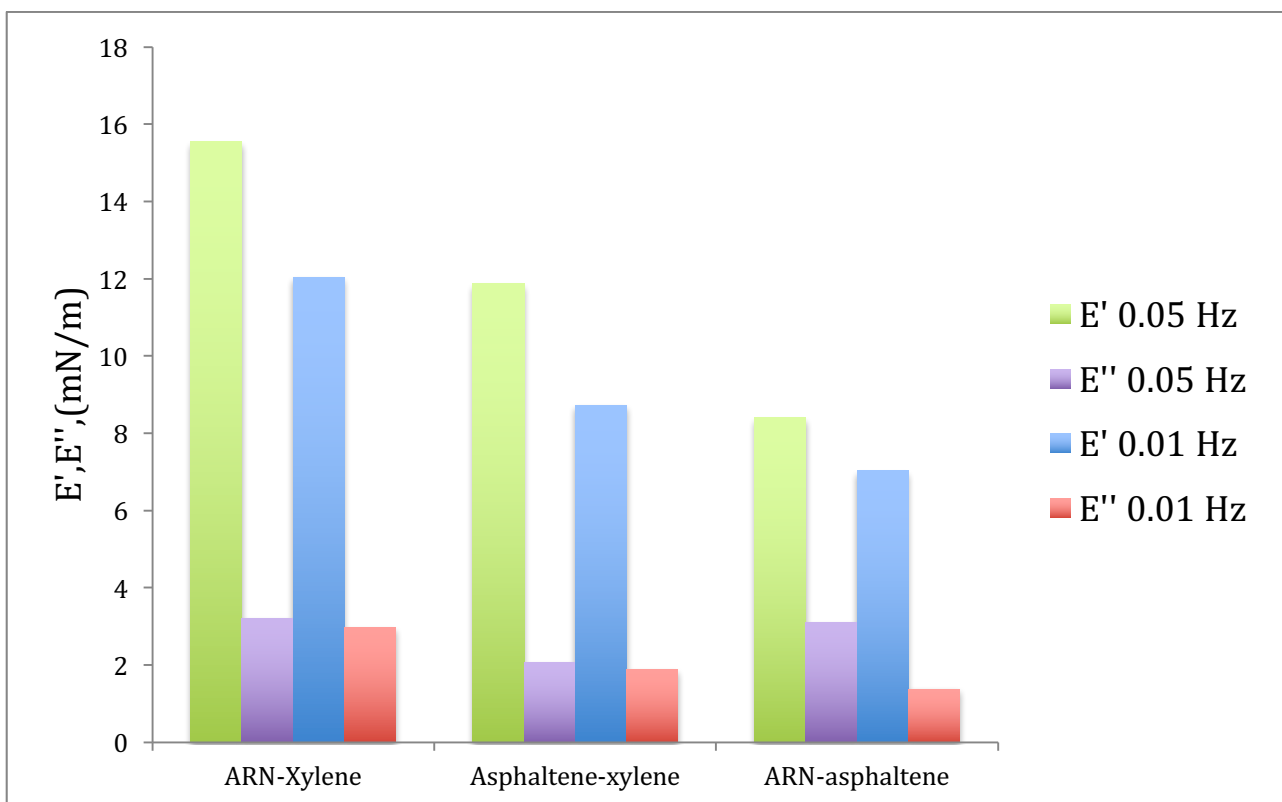

Figure 21: E' and E'' for the three different solutions using two frequencies at pH 7.

It can be seen in figure 21 that E' at 0,05 Hz of pure ARN is 8 values different from E' of asphaltenes + ARN.

Conversely, E' of pure asphaltenes is only 4 mN/m higher than E' of the mix. After that, we can say that the interface is covered by Asphaltenes, but pure ARN and pure Asphaltenes are quite similar.

4.2.2.3- Interaction Asphaltenes and ARN at pH 8

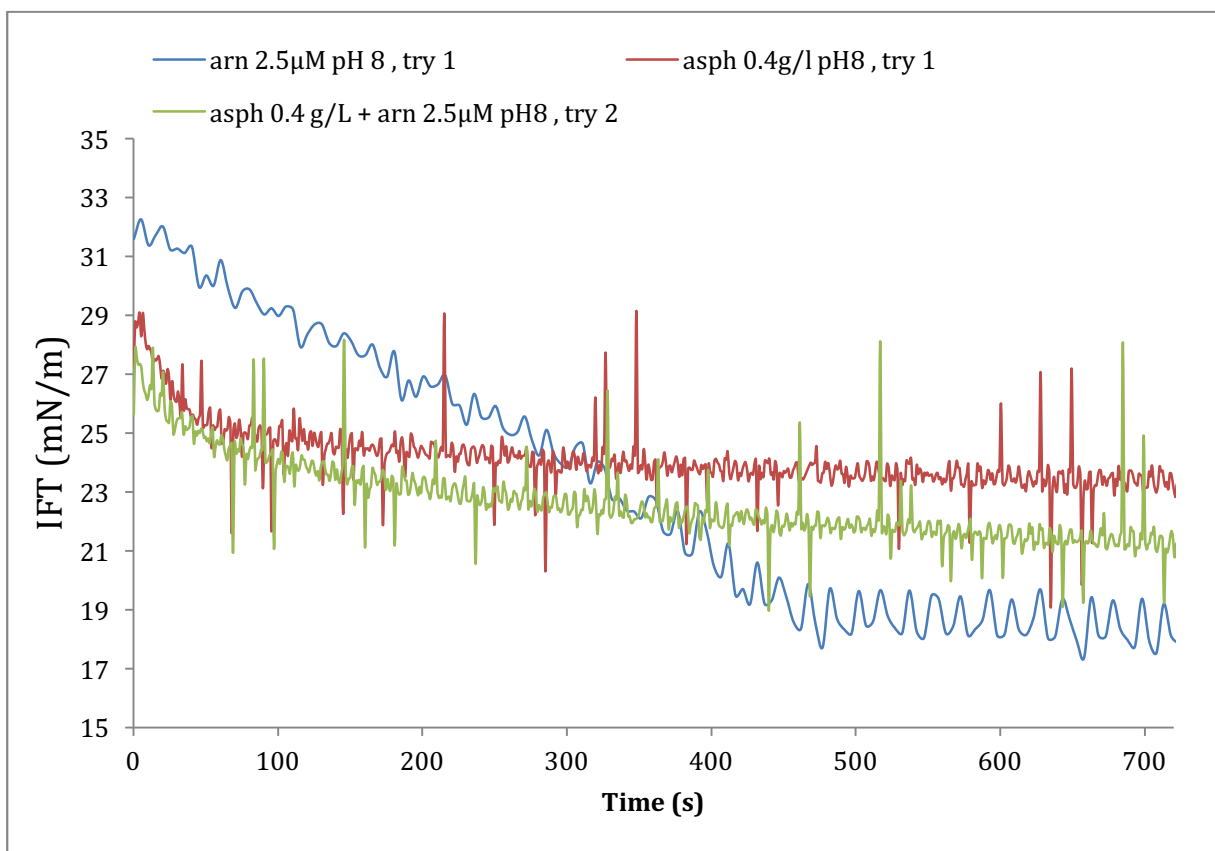

Figure 22: IFT as a function of time for the interaction between ARN and Asphaltenes at pH 8.

For example, for pH 8 is easier to determine, as it can be seen in [figure 22](#), the lines of pure asphaltenes are upper and closer to the mix of asphaltenes +ARN.

On the other hand, the adsorption of pure ARN are lower than the mixture of asphaltenes+ ARN, but still closer, so we have mostly asphaltenes in the interface.

However, there is presence of small concentration at ARN.

In the next figure, it can be known clearly the behaviour of adsorption and the type of structure can be obtained.

All the results and the whole figure are showed in [Appendix](#).

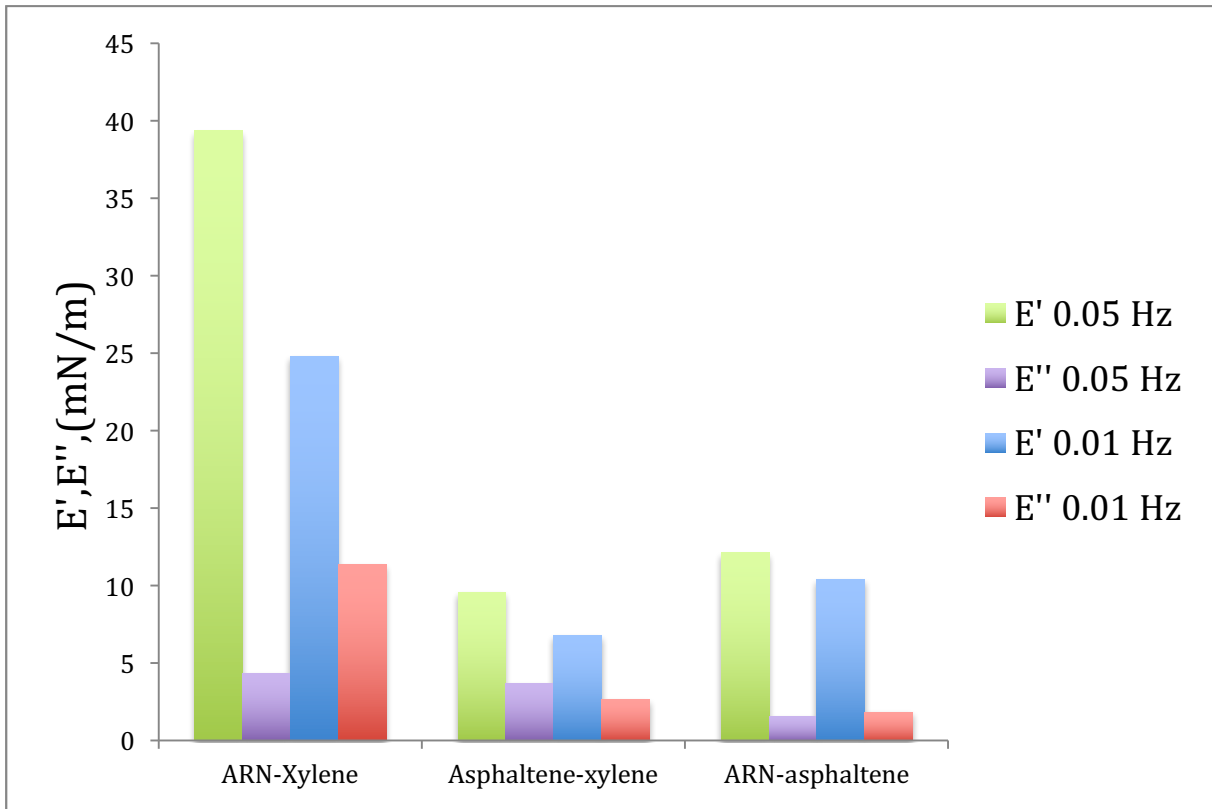

Figure 23: E' and E'' comparing different adsorption at pH 8, with two frequencies.

In the last [figure 23](#) is represented E' and E'' for each solution.

Principally, it can be said that E' of pure asphaltenes is quite similar to the mix, so the interface is mostly covered by asphaltenes as it is said before.

Now, if we focus on E' of ARN alone and Asphaltenes+ ARN, we can notice that there is a difference in a factor of 4, so we can say it is most likely no cross-linked structure.

4. 4.2.2.4- Interaction Asphaltenes and ARN at pH 9

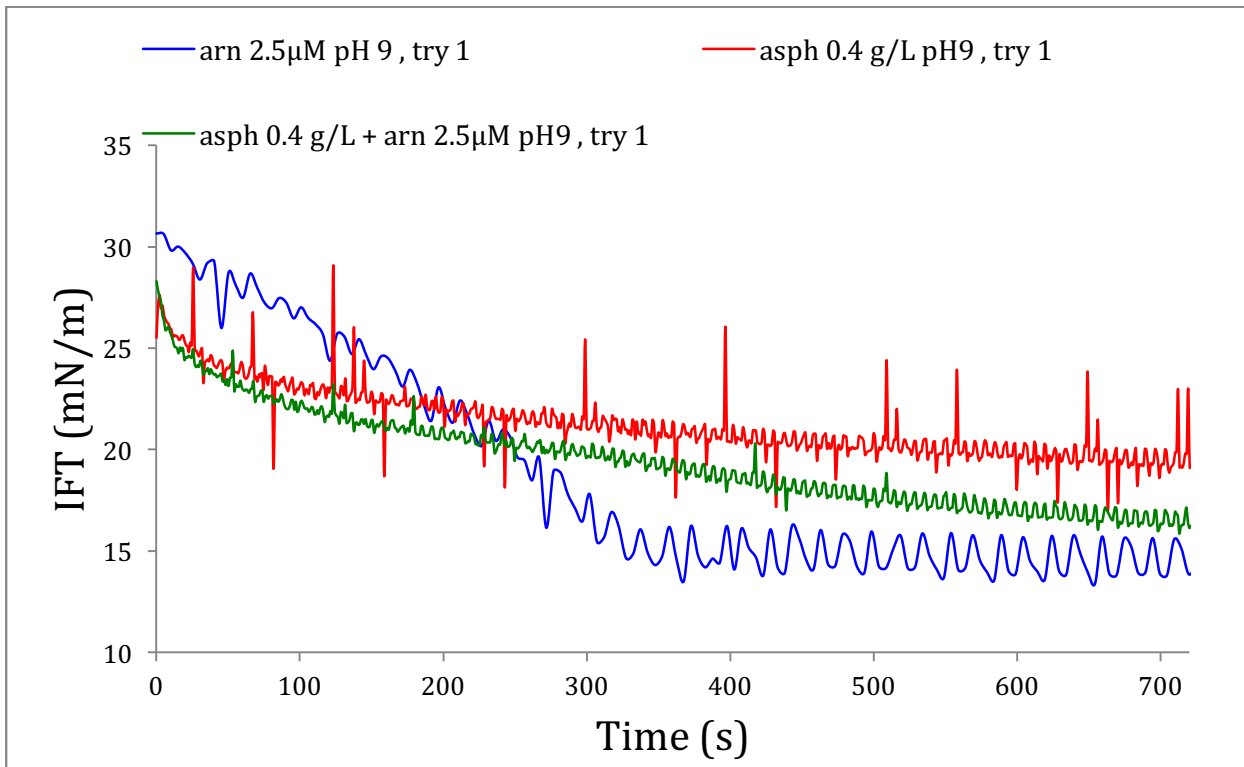

Figure 24: IFT against time for the interaction between ARN and Asphaltenes at pH 9.

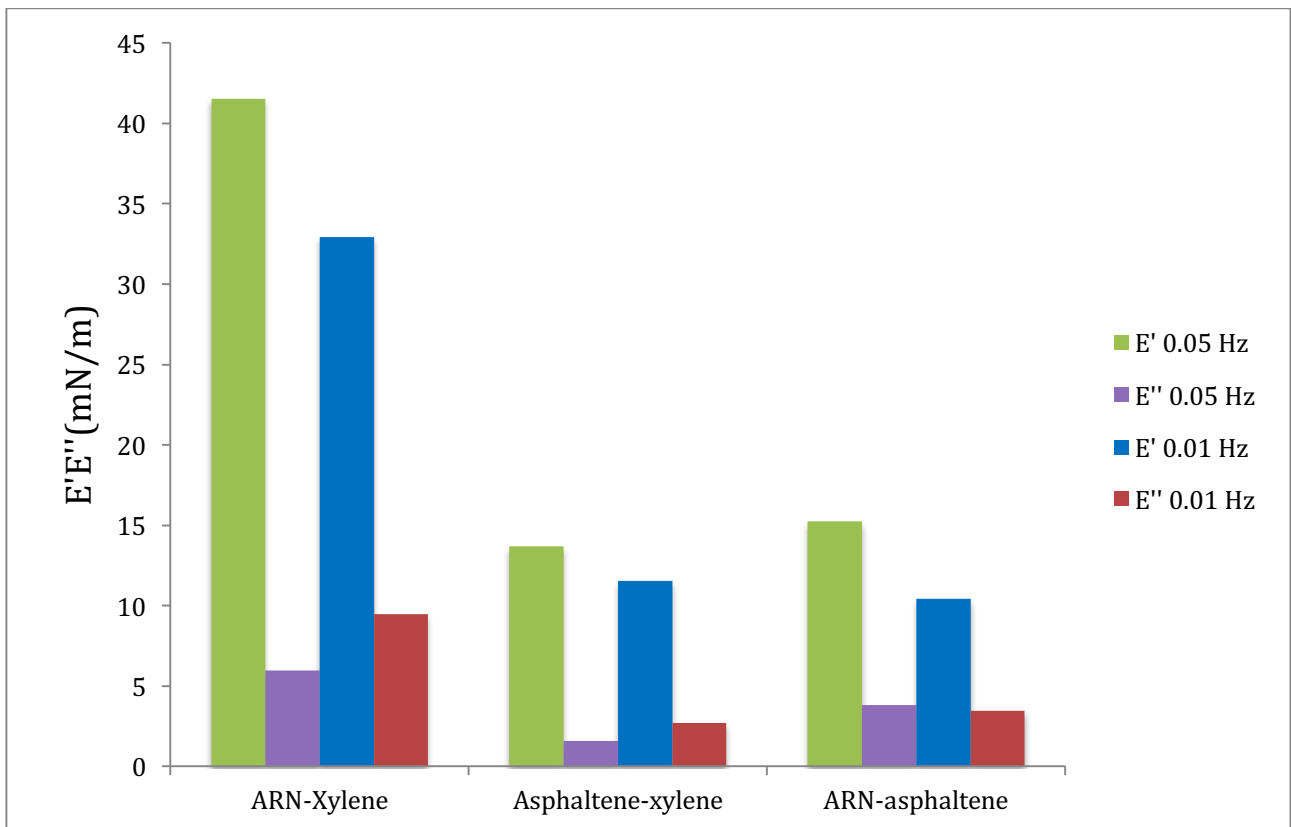

Figure 25: E' and E'' at two different frequencies using three types of solutions at pH 9.

For the competitive adsorption at pH 9, whether we look at the [figures 24 and 25](#), we can notice that the results are very similar that when pH 8 is used. Therefore, the interface is mostly completed by Asphaltenes, but there is a small presence of small concentration of ARN. In addition, there is most likely no cross-linked structure.

5. 4.2.2.5- Interaction Asphaltenes and ARN at pH 10

The same is obtained in the experiment when pH 10 is used as it can be seen in the graphs below.

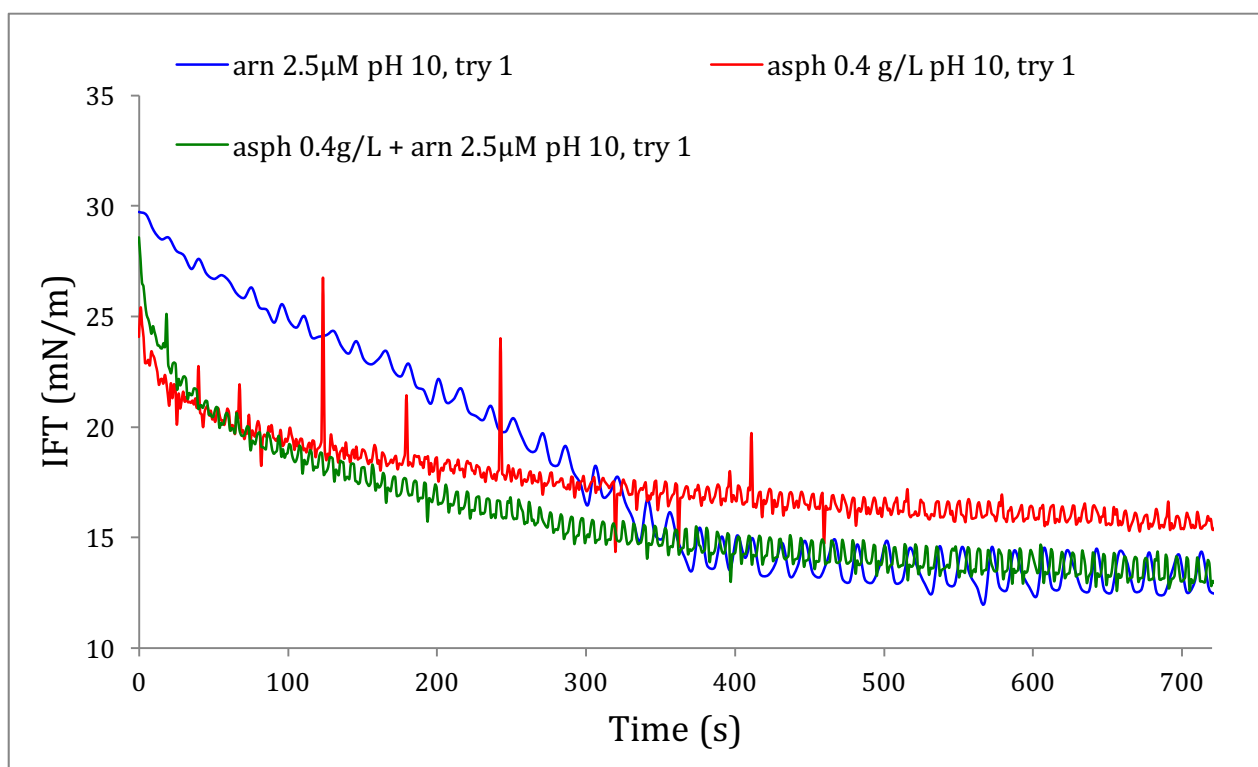

Figure 26: IFT as a function of time for the interaction between ARN and Asphaltenes at pH 10.

E' of pure asphaltenes is closer to asphaltenes+ARN and the figure is represented clearly, but the E' of pure ARN starts upper, but when the adsorption is finishing is resembling previous E' , so there is a concentration of ARN at the interface.

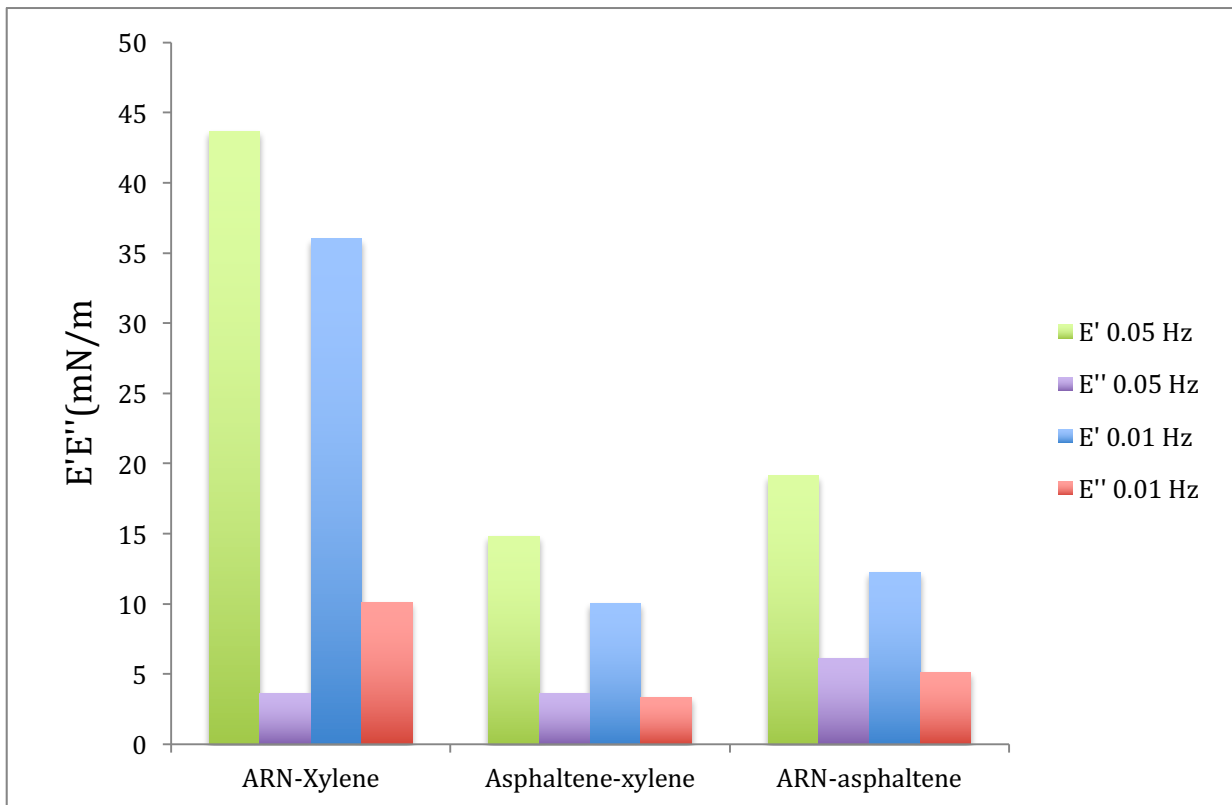

Figure 27: E' and E'' comparing different adsorption at pH 10, with two frequencies.

E' of pure ARN is far from E' of the mix asphaltenes+ARN, so the structure is most likely no cross-linked.

6. 4.2.2.6-Summary interactions as a function of pH at 20mM

To sum up all it was seen before, we are going to represent separately E' as a function of pH and Interfacial tension against pH.

In this way, it is easier to know the behaviour of different solutions at each pH.

The experiment is working under flow, with the following conditions [NaCl]:20mM, [ARN]:2.5 μ M, [Asph]:0,4g/L.

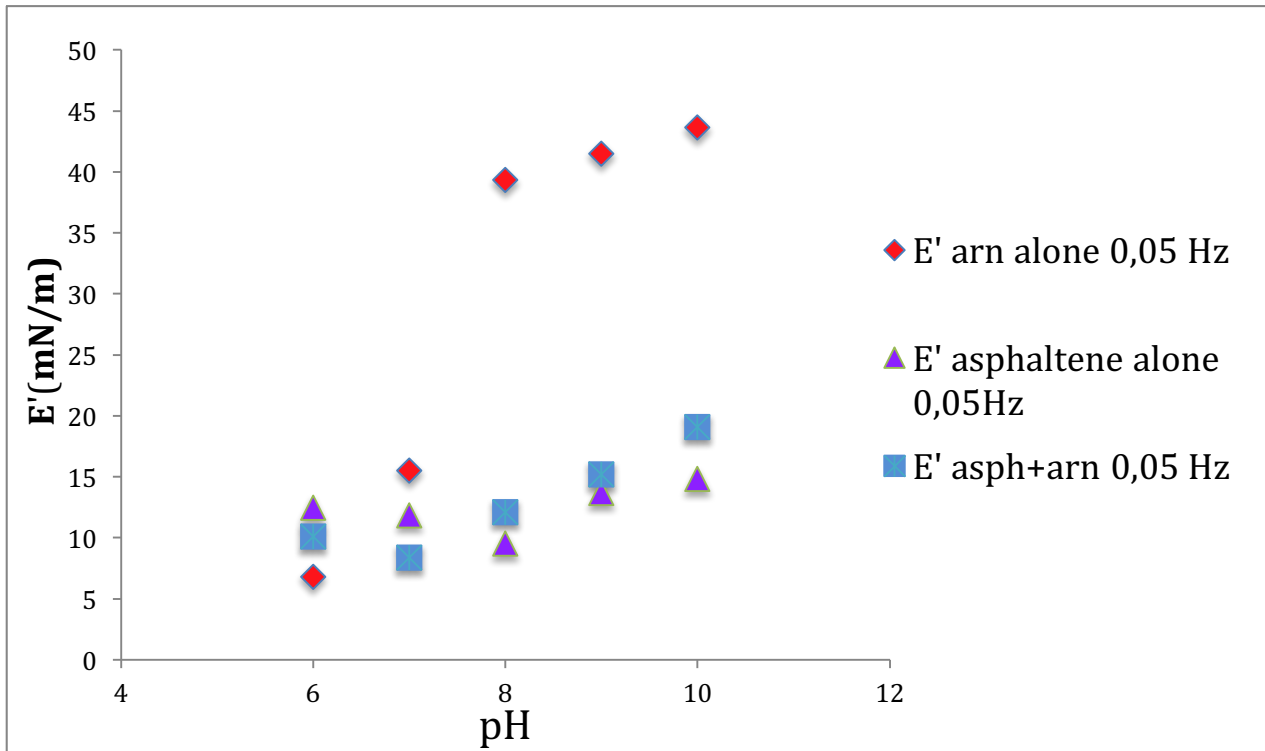

Figure 28: E' as a function of pH, comparing the three solutions at the same time.

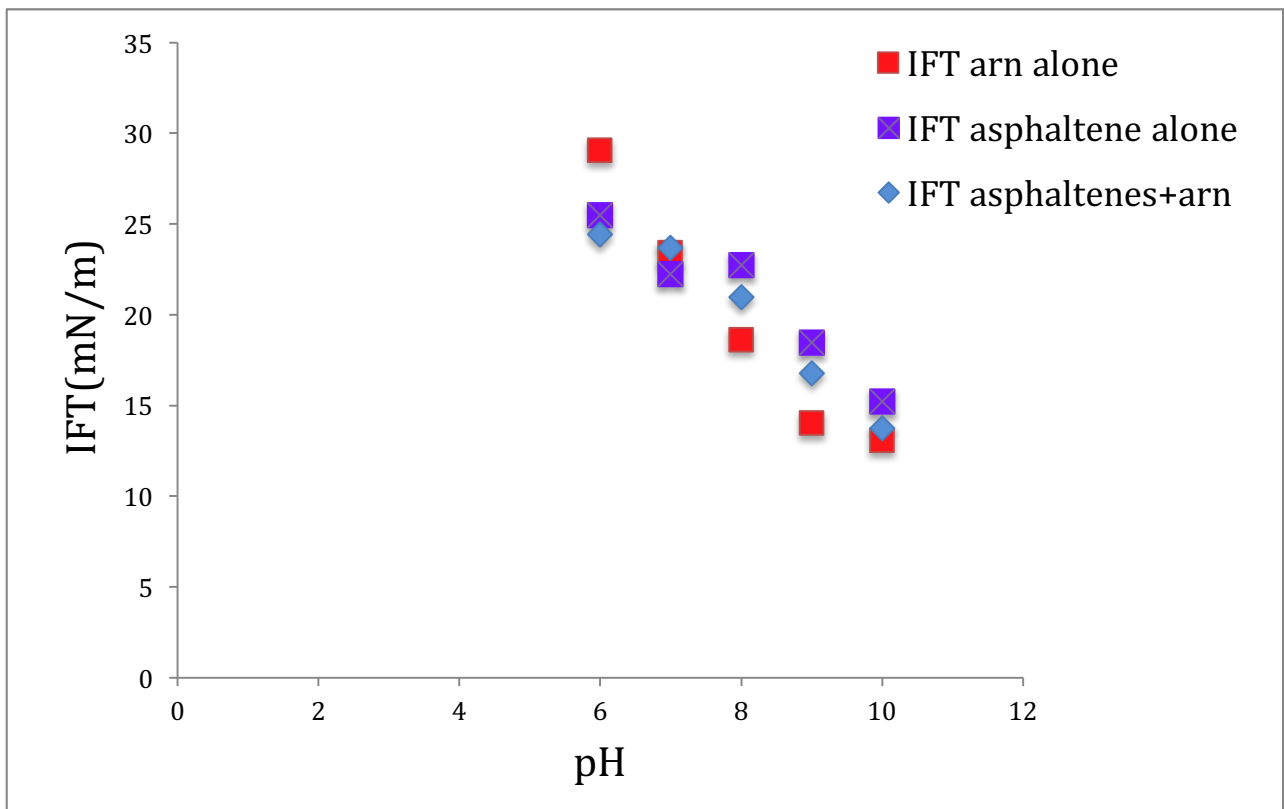

Figure 29: Interfacial tension as a function of pH, representing three solutions.

We can see in [figure 29](#), the interfacial tension of pure asphaltene from pH 6 to 7 is quite similar to interfacial tension of the mixed system asphaltenes+ ARN. Moreover, from pH 8 to 10, interfacial tension of ARN alone is closer to both previous interfacial tension.

On the other hand, whether look at the [figure 28](#) with E' , it can be observed that E' of pure ARN from pH 8 to 10 is far from the asphaltenes+ARN solution, in comparison with pH6 to 7 that is quite similar.

In conclusion:

- pH 6 and 7: Interface is completed by Asphaltenes.
- pH 8, 9 and 10: Mostly asphaltenes at interfaces, but small presence of ARN concentration, besides there is no cross-linked structure.

7. 4.2.2.7-Influence of [NaCl]

The following figures are a plot where is represented E' and interfacial tension as a function of pH.

Before, it could be seen the variations of these parameters when the solution buffer is 20mM, now the solution has a concentration of 600 mM, with $[ARN]=2.5\mu M$, $[Asph]=0.4g/L$, for the adsorption of Asphaltenes+ARN.

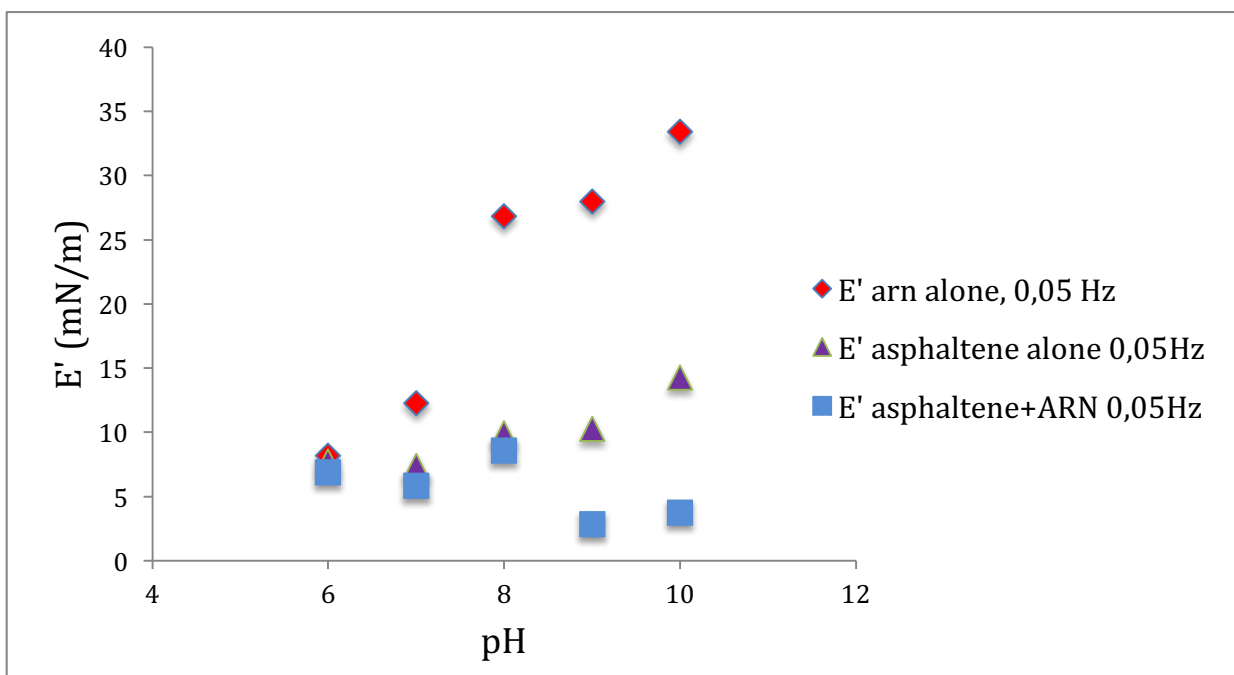

Figure 30: E' as a function of pH, comparing the three solutions at 600mM.

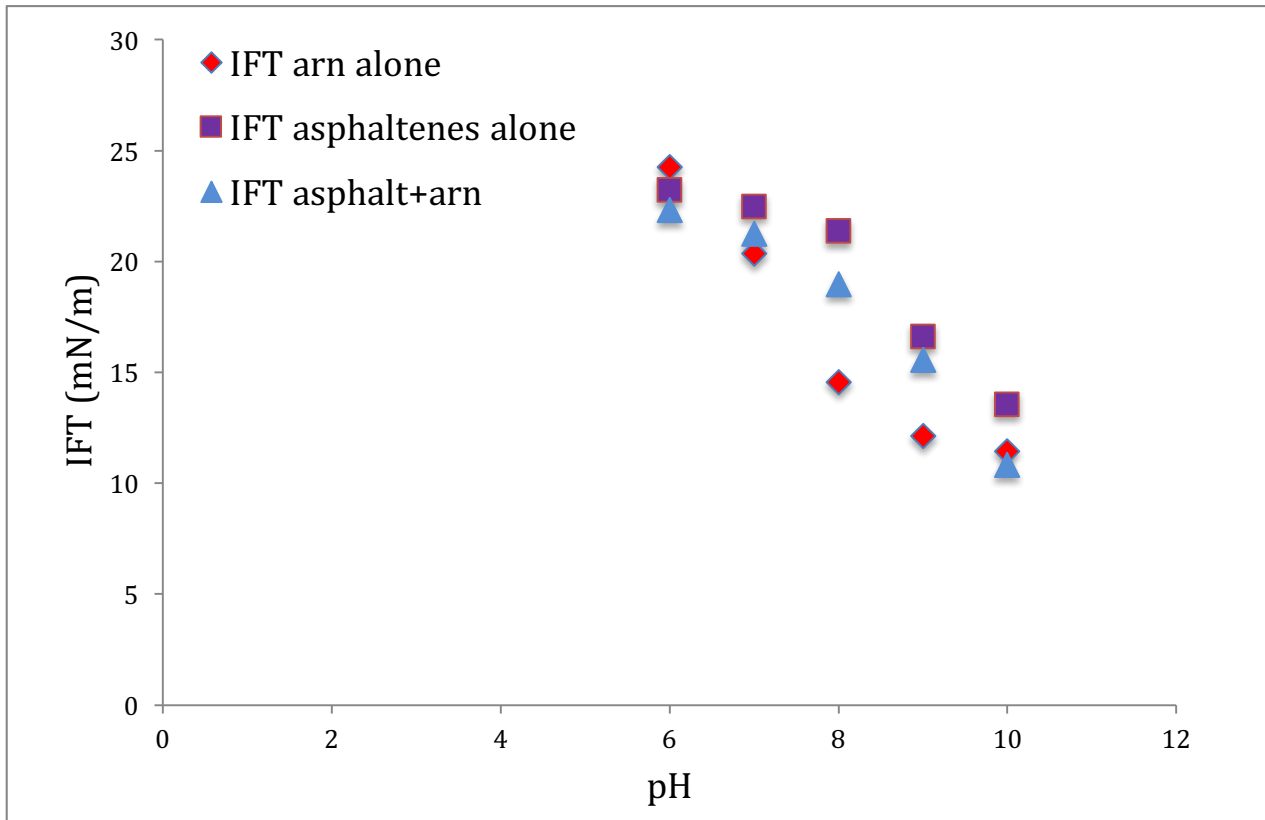

Figure 31: Interfacial tension against pH, representing three solutions at 600mM of NaCl

When the concentration is 600mM (figure 31), it can be noticed that the changes of E' and interfacial tension at each pH are almost the same than 20mM.

So, in this case when we change the salinity of our solution buffer, there is no change during the experiment and after the experiment comparing with 20mM.

Therefore, the experiment is not influenced by changing the salinity obtaining that the interface at pH 6 and 7 is fully covered by asphaltenes and from pH 8 to 10 is covered by asphaltenes, but there is a small concentration of ARN present on the interface.

4.2.3- Interfacial tension as a function of time at different concentrations of Asphaltenes

Now, in the figures bellow we are going to compare the interfacial tension as a function of time, with [NaCl]: 20mM + 10 mM CaCl₂ at pH 8 for the experiment with ARN alone 2.5 μ M, Asphaltenes (0.05, 0.1,0.4 and 1 g/L) and pure Asphaltene at different concentrations.

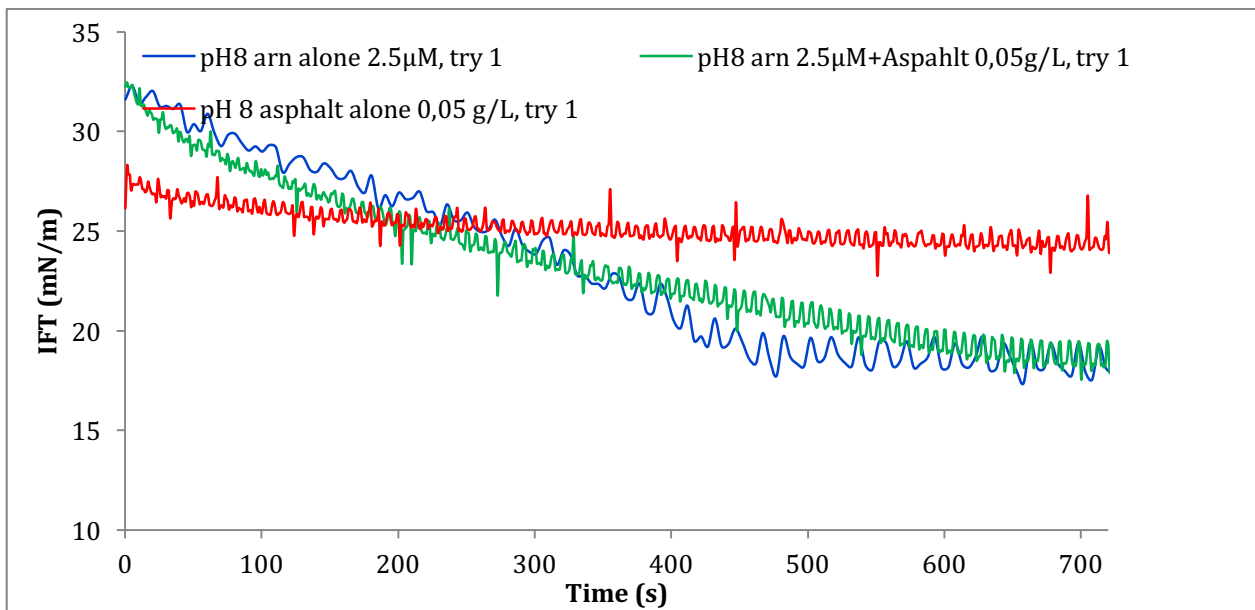

Figure 32: Comparison between ARN 2.5 μ M, asphaltene solution 0,05 g/L and a mixture of ARN+Asphaltenes.

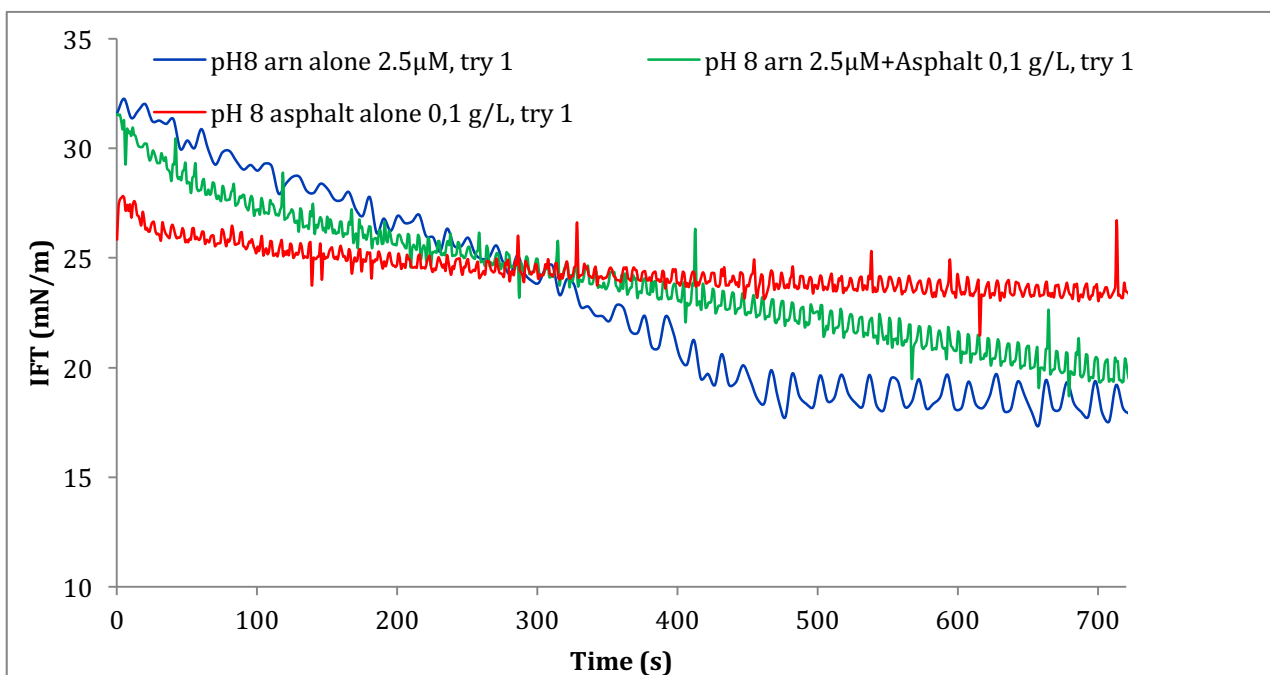

Figure 33: Comparison between ARN 2.5 μ M, asphaltene solution 0,1 g/L and a mixture of ARN+Asphaltenes.

For the figure 32, with a concentration of Asphaltenes of 0.05g/L, it can easily be seen the presence of ARN on the interface. On the other hand, Figure 33 shows a plot with a concentration of Asphaltenes of 0,1g/L, and is obvious there is also a mixture at the interface.

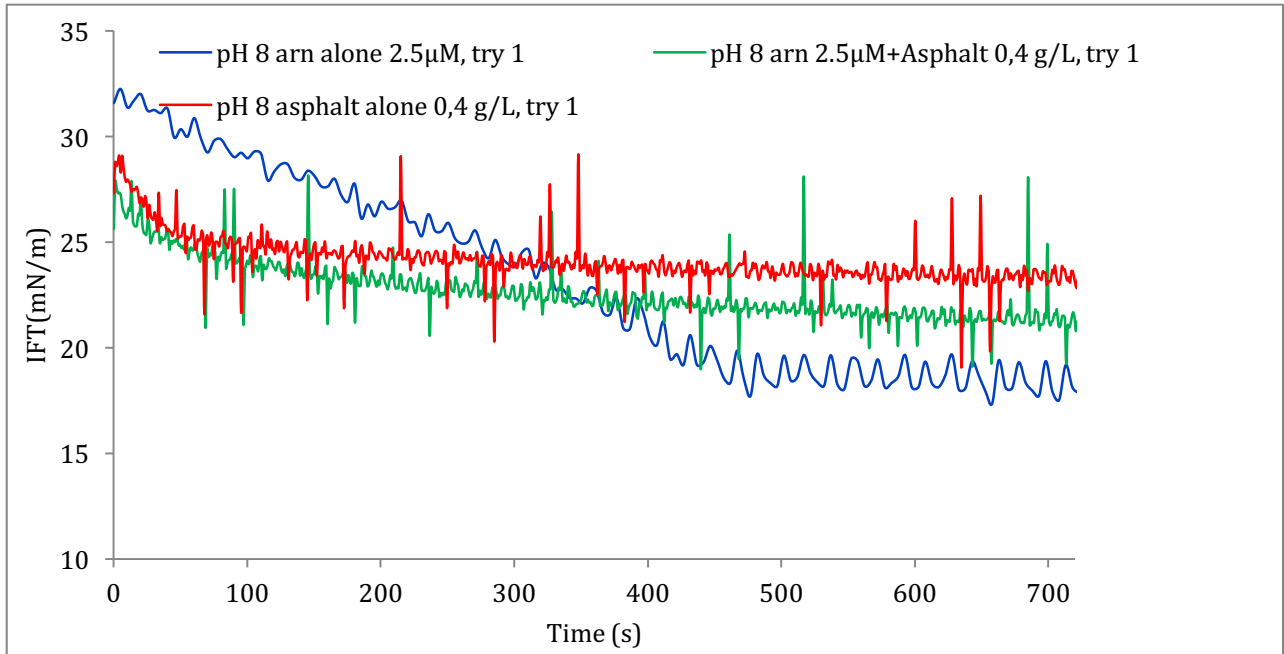

Figure 34: Comparison between ARN 2.5µM, asphaltene solution 0,4 g/L and a mixture of ARN+Asphaltenes.

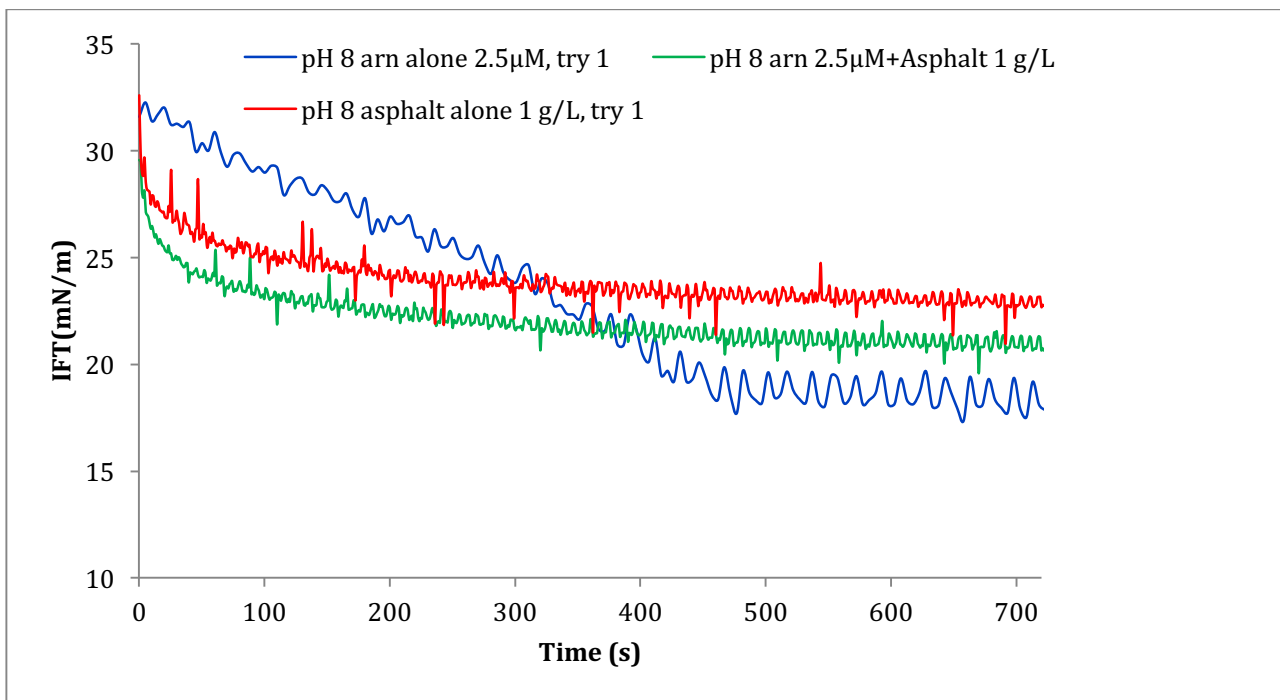

Figure 35: Comparison between ARN 2.5µM, asphaltene solution 1 g/L and a mixture of ARN+Asphaltenes.

In figures 34 and 35 are represented interfacial tension as a function of time when the concentration of Asphaltenes are 0,4 and 1 g/L. From the plot 34, it can be observed that there is Asphaltenes at interfaces, but exists a small concentration of ARN. On the other hand, when the concentration is 1 g/L (figure 35) is mostly covered by asphaltenes but it could exist a small presence of ARN on the interface.

8. 4.2.3.1-Influence of Asphaltene concentration

In this part is going to be seen the influence of the concentration of asphaltenes in the adsorption at interface when the pH=8 for each experiment with a solution buffer of 20mM.

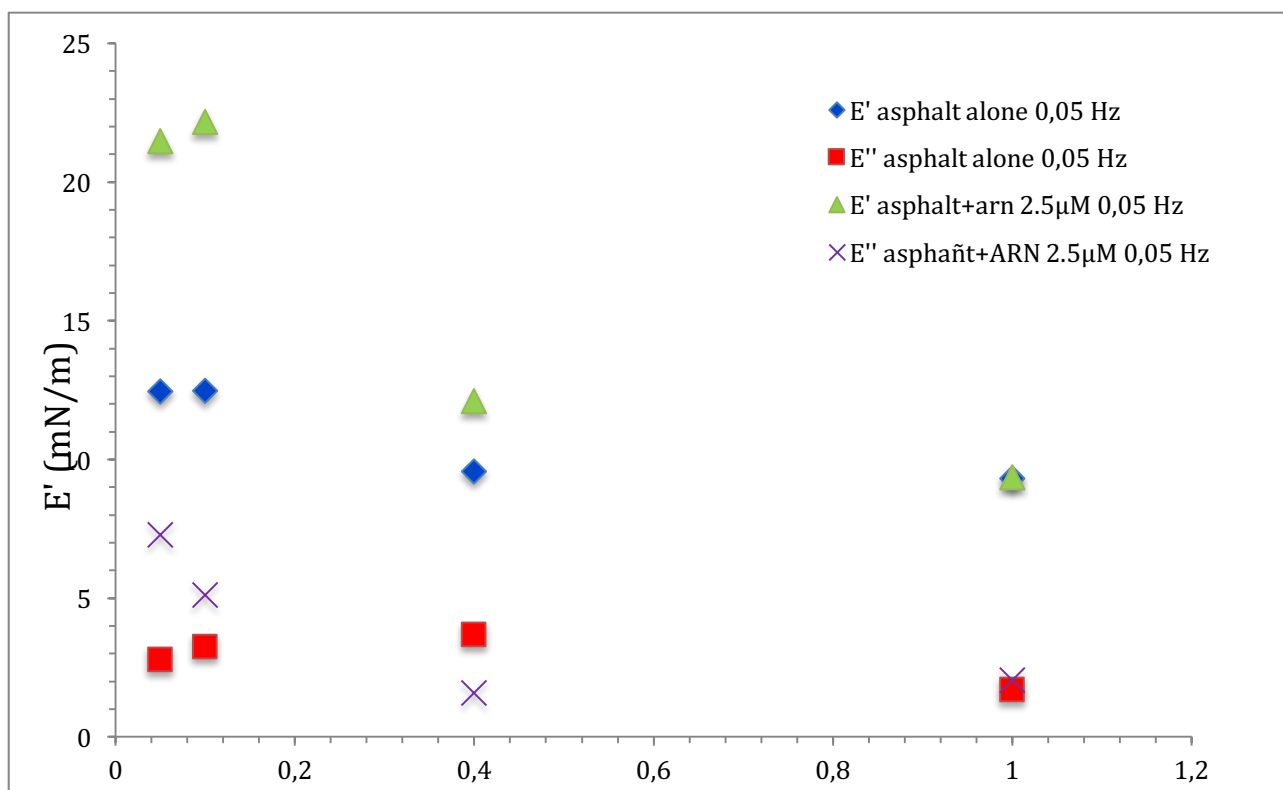

Figure 36: The plot of viscoelastic modulus measured of different from the mixture of ARN and Asphaltenes at different concentrations of asphaltenes.

We notice from the figure 36 that E' for the system of Asphaltene alone for both concentration 0,05 and 0,1 g/L is quite similar around 22mN/M, and is quite low compared to ARN alone around 40mN/m.

On the other hand, we can see that E' decrease gradually until the concentration of Asphaltenes is 0,1g/L, and then there is a sharp drop to the concentration of 0,4 g/L. As we noticed before, it exists a huge difference when in the system there is Asphaltenes instead of pure ARN, so the gel formation is diminished when we have asphaltenes in the system.

Therefore, we can say that either asphaltenes and ARN compete to adsorb at the interface. In addition, after seeing the results, asphaltenes are hindering ARN's molecules adsorption.

5. CONCLUSION

The whole project is based on the film formed at interface by the interaction between oil and water on the interface. It has been used coaxial capillary to have a flow of ARN in a medium containing calcium ions at different pHs.

When the solution is ARN, as it could be seen the kinetic of adsorption is favoured when the ARN concentration increases, as well as the dilatational moduli E' increase when the concentration of ARN increases. In addition, ARN is responsible of naphthenic gel formation when the pH is higher.

ARN transition, formation of an interfacial gel between pH 7 and 8, is independent of concentration of ARN and NaCl. It can be seen that the gel tends to be weaker when the concentration of NaCl is 600 mM compared to 20Mm.

Interaction asphaltenes/ARN as a function of pH:

- pH=6 and 7, the interface is covered by asphaltenes.
- pH=8,9 and 10, the interface is mostly covered by asphaltenes, but there is a small concentration of ARN. No gel formation.

Influence of concentration of Asphaltenes:

- When the concentration is 0,05 g/L, it can be seen that the interface is covered by ARN.
- 0,1 g/L, it is easily to see that there is a mixture of Asphaltenes-ARN.
- 0,4g/L and 1g/L, is covered by asphaltenes, but it can exist a small concentration of ARN at interfaces.

6. REFERENCES

- [1] Sreedhar SUBRAMANIAN, Sébastien Simon and Johan sjöblom. Interfacial dilational rheology properties of films formed at the oil/water interface by reaction between tetrameric acid and calcium ion.
- [2] J. Sjöblom, S. Simon, and Z. Xu, “The chemistry of tetrameric acids in petroleum,” *Advances in Colloid and Interface Science*, vol. 205, pp. 319–338, Mar. 2014.
- [3] Theory interfacial tension available online:
<https://www.kruss.de/services/education-theory/glossary/interfacial-tension/>
- [4] F. Ravera, G. Loglio, and V. I. Kovalchuk, “Interfacial dilational rheology by oscillating bubble/drop methods,” *Current Opinion in Colloid & Interface Science*, vol. 15, no. 4, pp. 217–228, Aug. 2010.
- [5] Erland L. Nordgård, Heléne Magnusson, Ann-Mari D. Hanneseth, and Johan sjöblom. Model compounds for C₈₀ isoprenoid tetraacids: Part II. Interfacial reactions, physicochemical properties and comparison with indigenous tetraacids
- [6] Mohd Faidzul Hakim Mohd Adnan. The study of interfacial rheology of system containing ARN under flow condition.

7. APPENDIX

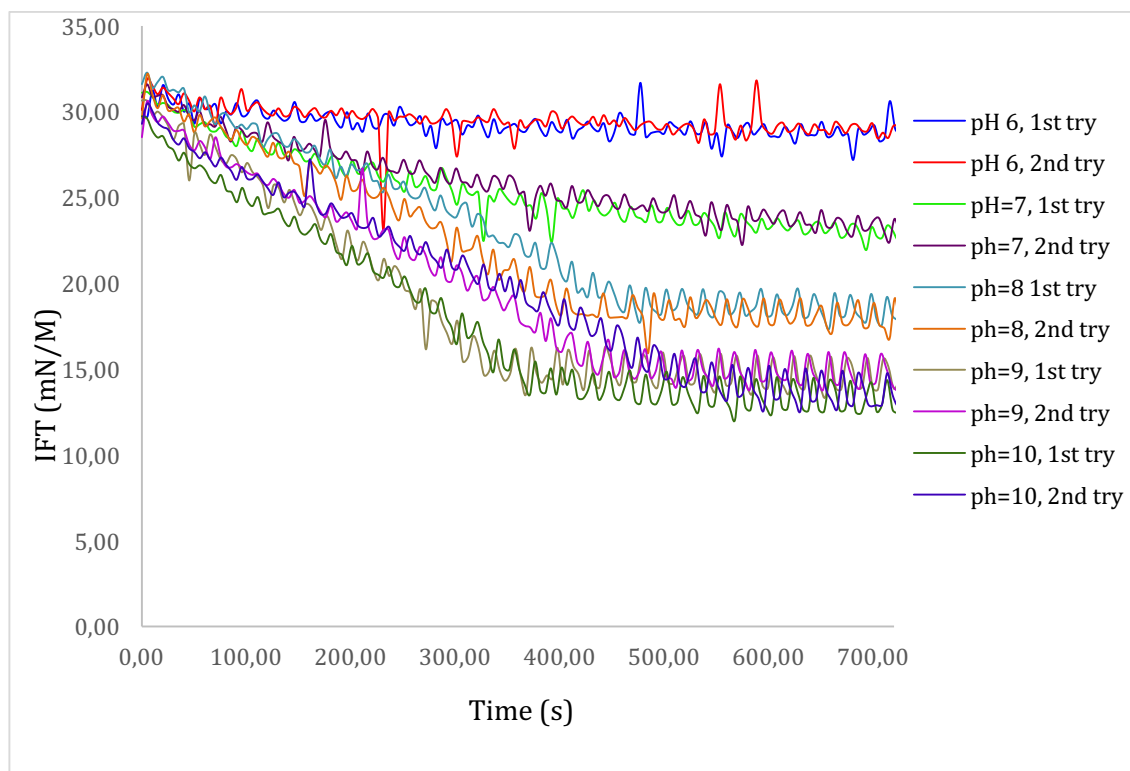

Figure 9: Interfacial tension against pH, with $[ARN]: 2.5\mu M$ and $[NaCl]: 20mM$

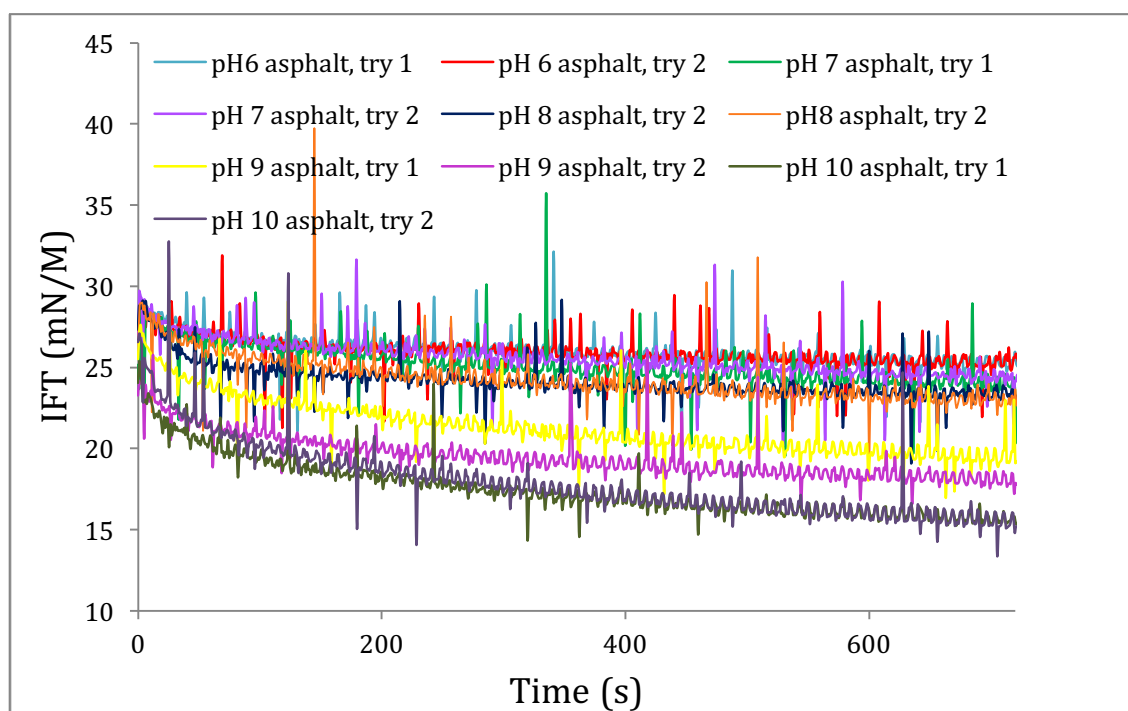

Figure 16: Kinetic of adsorption of asphaltenes at liquid/liquid interface. $[NaCl]: 20mM$ and $[Asph]: 0.4g/L$

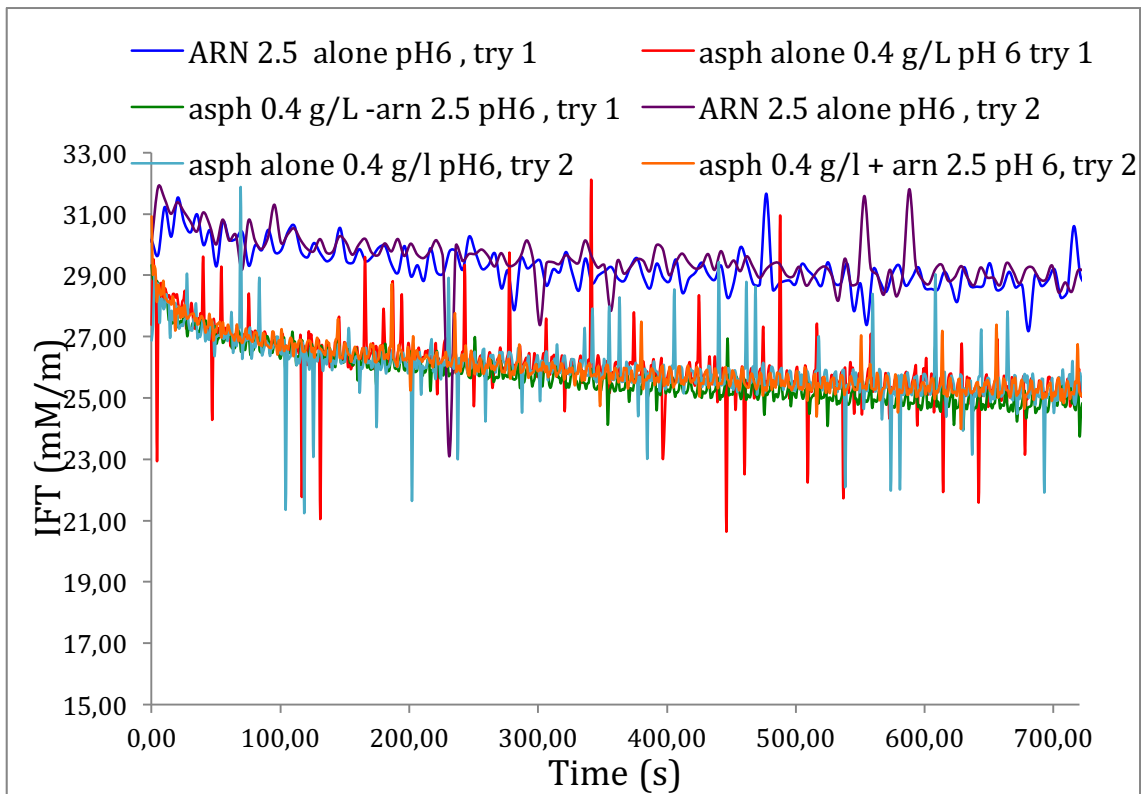

Figure 18: IFT as a function of time, until 720s when asphaltenes and ARN are mixed. $[NaCl]:20Mm$, $[ARN]:2.5\mu M$, $[Asph]:0.4g/L$ at pH 6

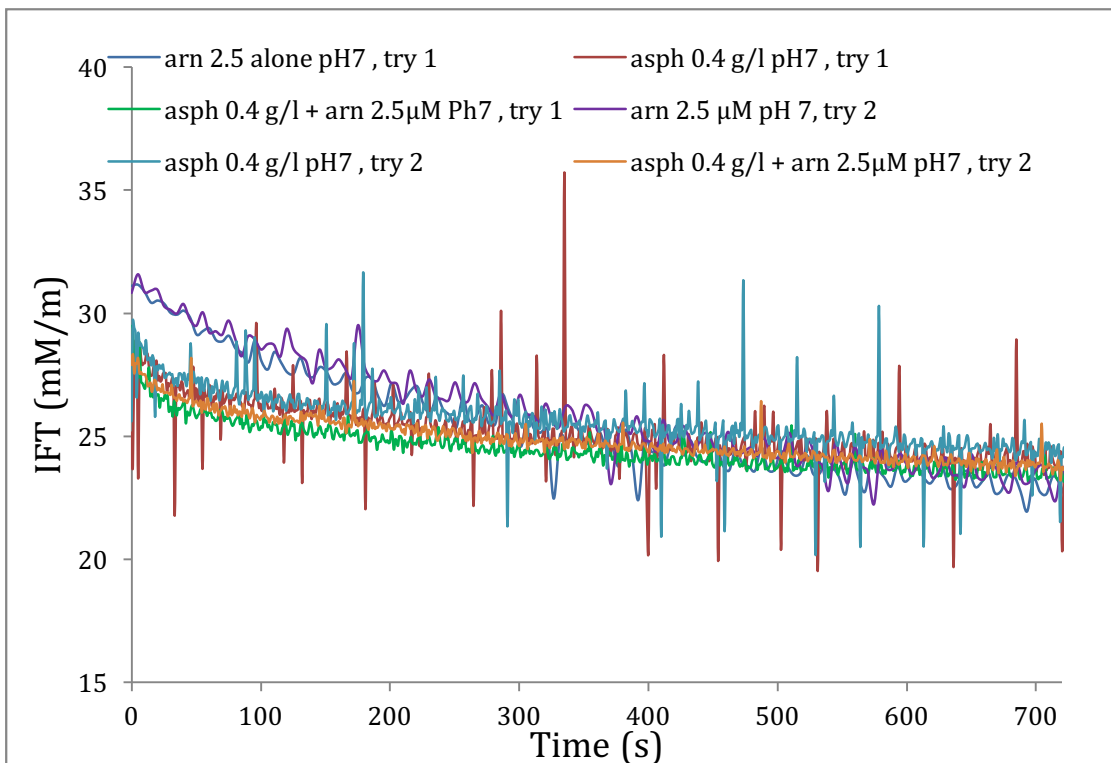

Figure 20: IFT against time for the interaction between ARN and Asphaltenes at pH 7.

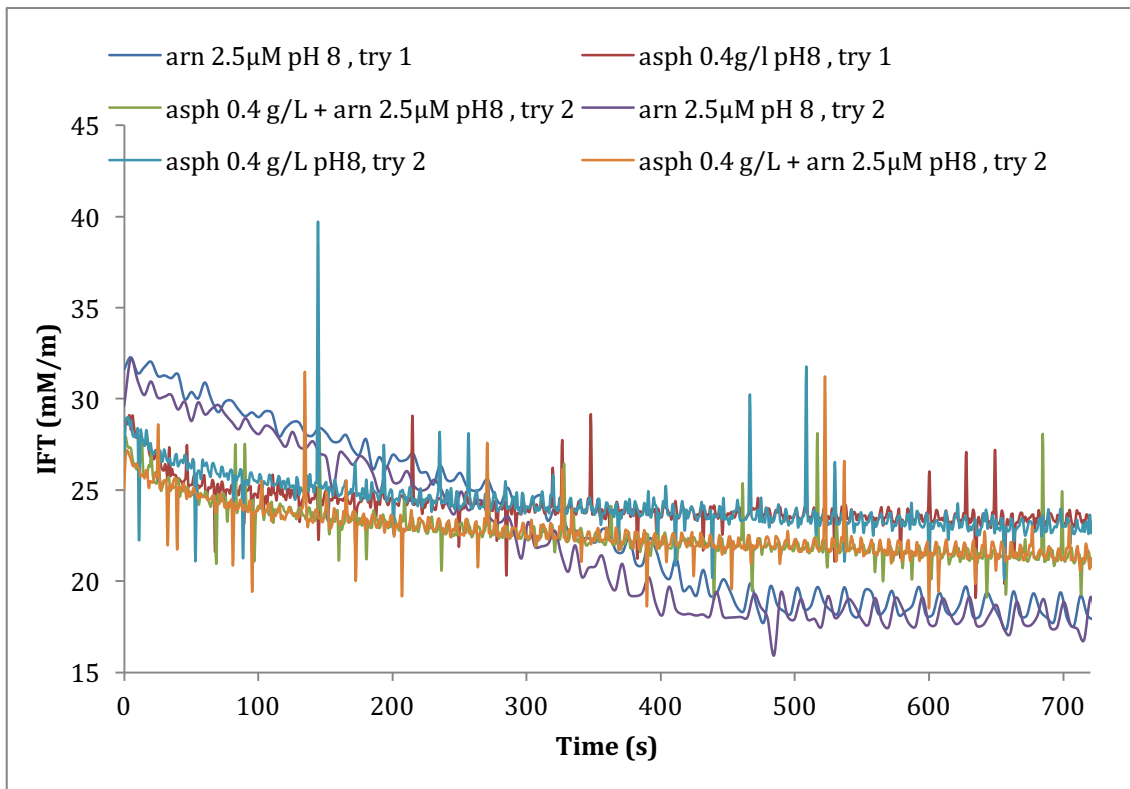

Figure 22: IFT as a function of time for the interaction between ARN and Asphaltenes at pH 8.

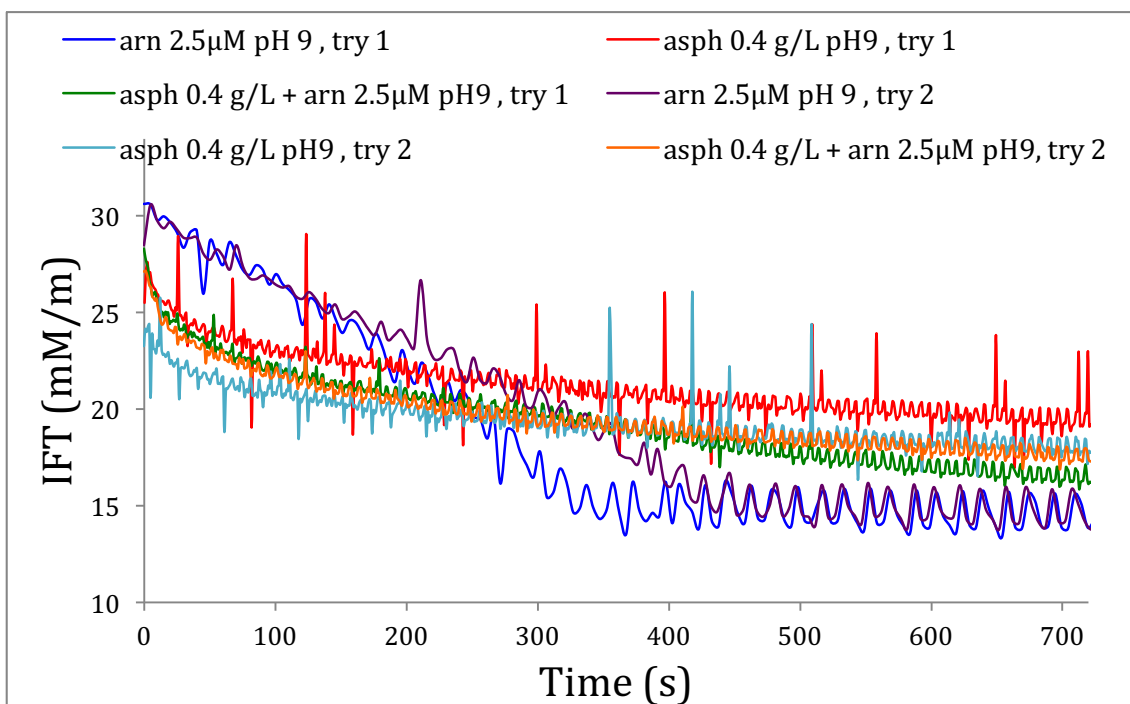

Figure 24: IFT against time for the interaction between ARN and Asphaltenes at pH 9.

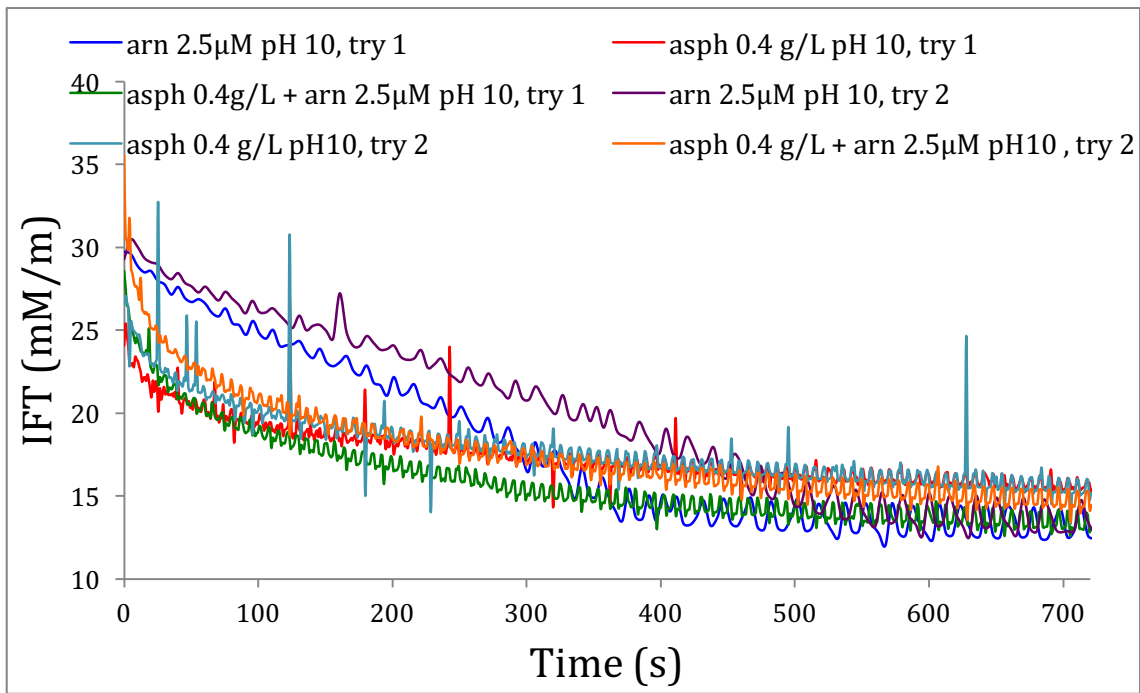

Figure 26: IFT as a function of time for the interaction between ARN and Asphaltenes at pH 10.

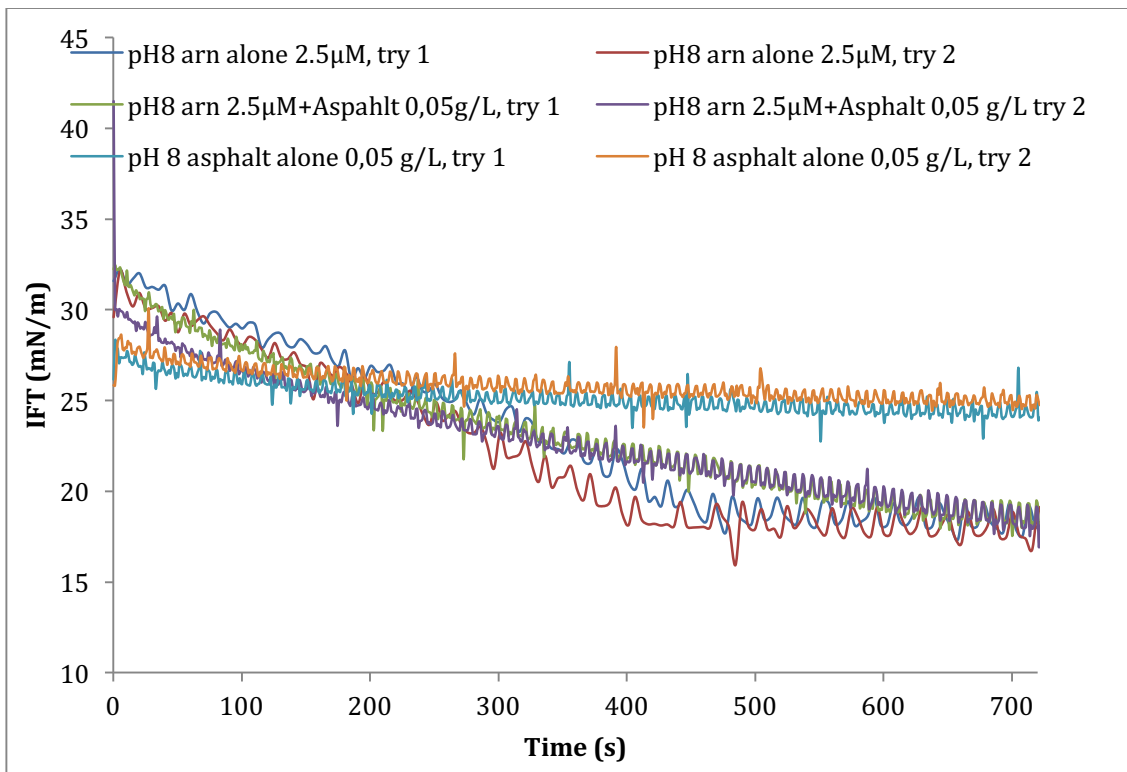

Figure 32: Comparison between ARN 2.5µM, asphaltene solution 0,05 g/L and a mixture of ARN+Asphaltenes.

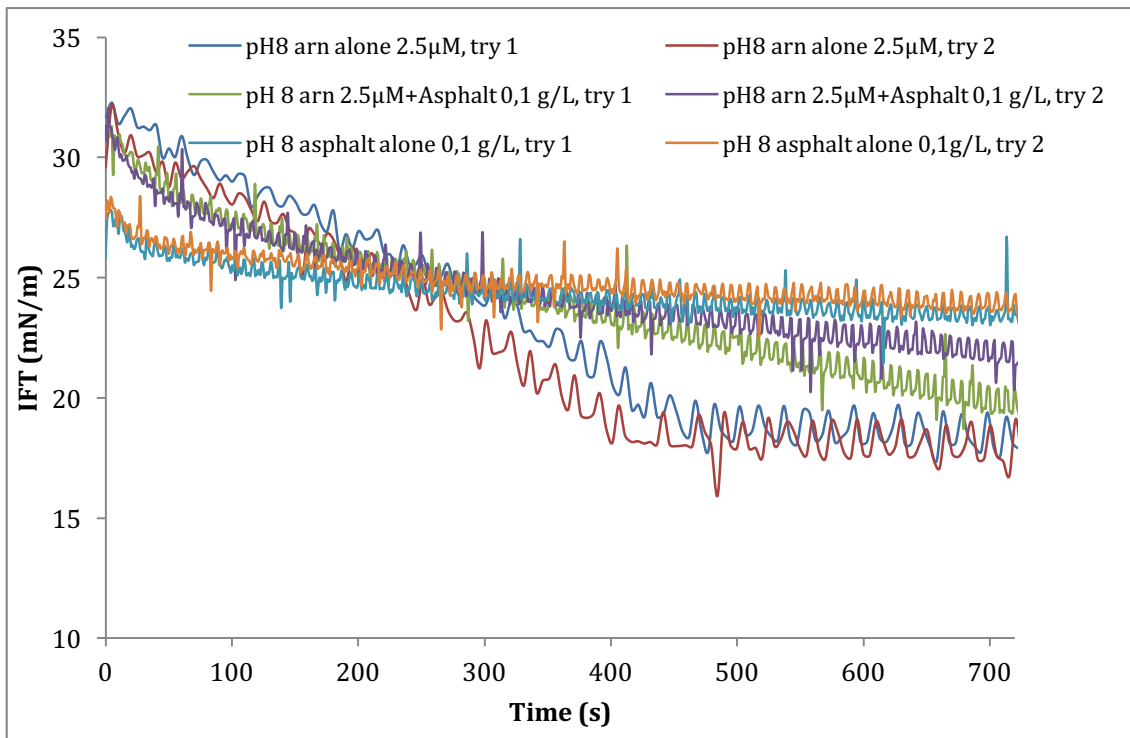

Figure 33: Comparison between ARN 2.5µM, asphaltene solution 0,1 g/L and a mixture of ARN+Asphaltenes.

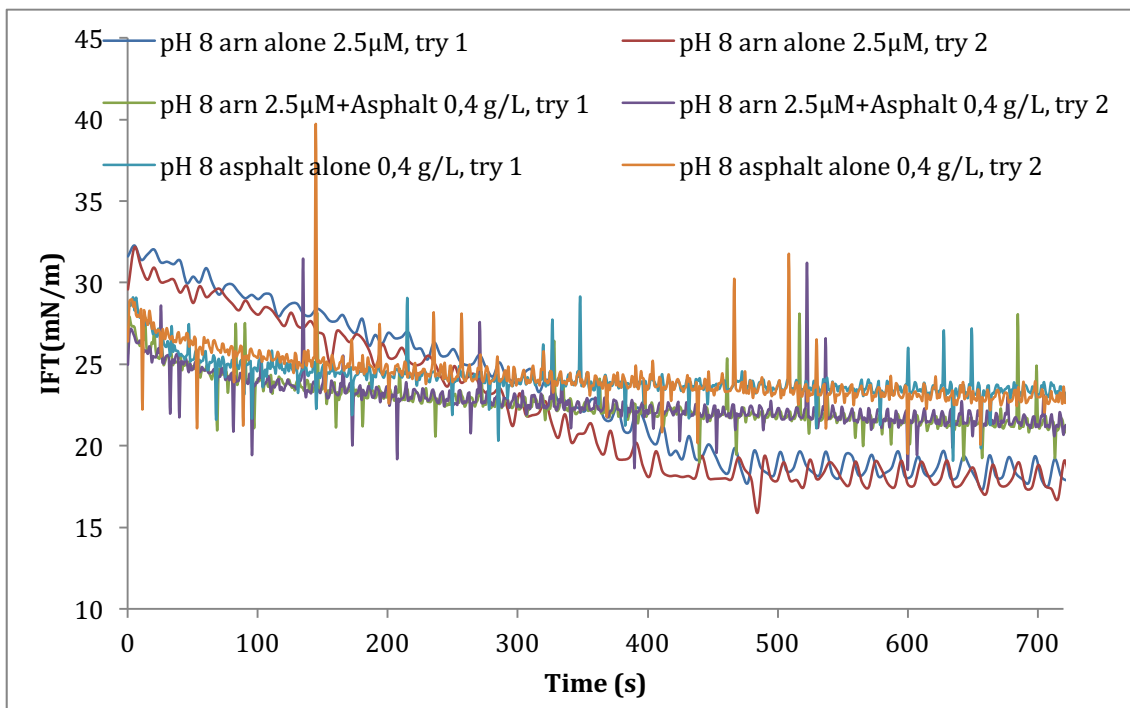

Figure 34: Comparison between ARN 2.5µM, asphaltene solution 0,4 g/L and a mixture of ARN+Asphaltenes.

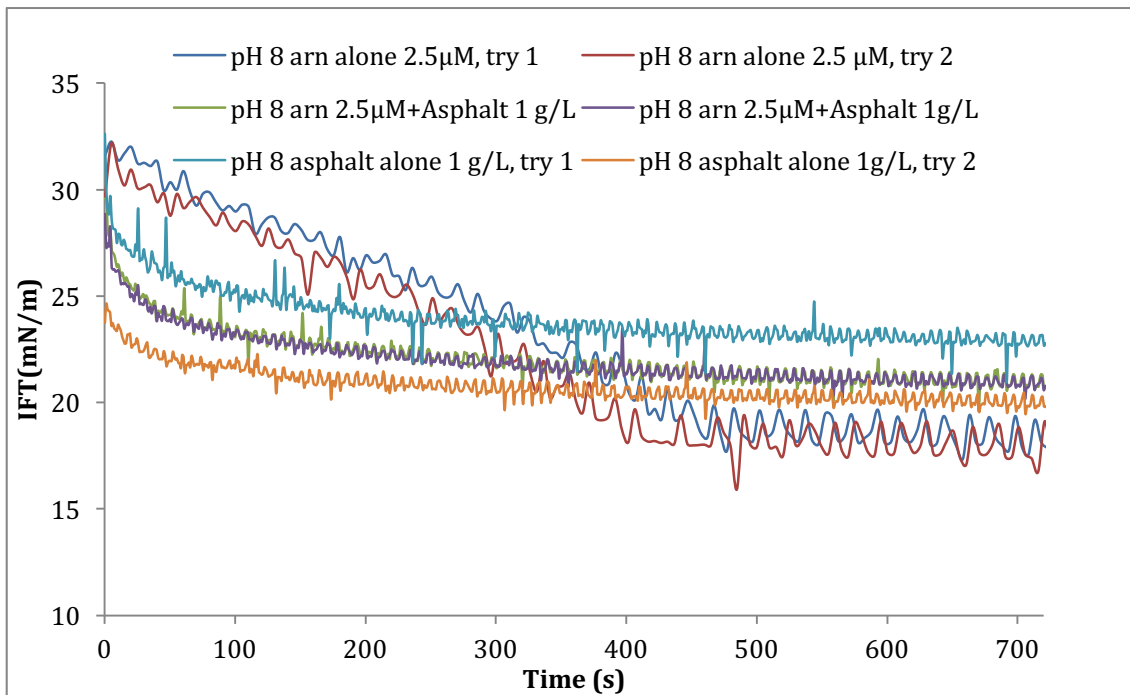

Figure 35: Comparison between ARN 2.5µM, asphaltene solution 1 g/L and a mixture of ARN+Asphaltenes.

NaCl=20 mM, Ca=10 mM, ARN=2.5µM					
		100 s		20 s	
pH	IFT at 721 s	E' mN/m	E''	E'	E''
6	29,00	5,57	-0,55	6,96	3,37
6	29,15	6,96	3,37	6,68	-0,33
7	23,098	11,43	2,49	15,22	3,84
7	23,752	12,63	3,48	15,88	2,58
8	18,129	24,55	11,97	39,35	4,36
8	19,125	25,08	10,8	39,42	4,36
9	13,872	33,9	8,72	42,25	5,99
9	14,178	31,95	10,22	40,78	5,94
10	12,632	36,94	9,17	43,51	4,29
10	13,525	35,12	11,01	43,85	3,06

NaCl=20 mM, Ca=10 mM, [Asph]= 0,4 g/L		100 s		20 s	
pH	IFT at 721 s	E' mN/m	E''	E'	E''
6	25,22	9,84	1,83	12,33	2,94
6	25,812	10,18	1,55	12,67	2,31
7	20,327	9,1	1,99	12,07	3,48
7	24,148	8,34	1,8	11,67	0,67
8	22,84	8,39	3,28	10,61	3,95
8	22,63	5,22	2,12	8,5	3,43
9	19,121	10,51	3,35	14,37	2,25
9	17,846	12,59	2,02	13,01	0,9
10	15,354	8,86	2,82	12,88	3,77
10	15,148	11,28	3,99	16,82	3,56

NaCl=20 mM, Ca=10 mM, [Asph]= 0,1 g/L and [ARN]=2.5µM		100s		20s	
pH	E'	E''	E'	E''	
8	16,89	4,53	21,95	9,49	
8	16,17	3,67	20,98	5,07	

NaCl=20 mM, Ca=10 mM, [Asph]= 0,05 g/L and [ARN]=2.5µM		100s		20s	
pH	E'	E''	E'	E''	
8	14,88	7,29	22,72	5,96	
8	14,56	6,59	21,59	4,28	

NaCl=20 mM, Ca=10 mM, [Asph]= 1 g/L and [ARN]=2.5µM		100s		20s	
pH	E'	E''	E'	E''	
8	6,19	3,14	8,98	3,32	
8	7,12	1,74	9,73	0,78	

NaCl=20mM, Ca=10 mM, [Asph]= 0,4 g/L and [ARN]=2.5μM					
		100 s	20 s		
pH	IFT at 721 s	E' mN/m	E''	E'	E''
6	23,764	8,74	0,79	9,88	-2,62
6	25,091	8,81	1,73	10,35	-0,67
7	23,66	9,07	2,05	9,91	5,79
7	23,748	4,98	0,73	6,9	0,44
8	20,789	10,61	1,72	12,69	0,8
8	21,204	10,22	2,01	11,53	2,36
9	16,262	10,04	3,85	15,66	3,61
9	17,319	10,83	3,09	14,83	4
10	13,035	12,54	4,99	19,28	4,45
10	14,458	11,94	5,33	18,96	7,8

NaCl=20 mM, Ca=10 mM, [Asph]= 0,05 g/L					
		100s	20s		
pH		E'	E''	E'	E''
8		10,06	1,3	12,2	1,09
8		12,26	0,77	12,68	4,46

NaCl=20 mM, Ca=10 mM, [Asph]= 0,1 g/L					
		100s	20s		
pH		E'	E''	E'	E''
8		10,64	1,71	12,78	2,33
8		10,17	1,97	12,15	4,15

NaCl=20 mM, Ca=10 mM, [Asph]= 1 g/L					
		100s	20s		
pH		E'	E''	E'	E''
8		6,07	1,77	8,22	4,14
8		9,16	1,29	10,39	-0,75