



Norwegian University of  
Science and Technology

# Design of a Small Autonomous Passenger Ferry

**Gina Havdal**

**Christina Torjussen Heggelund**

**Charlotte Hjelmseth Larssen**

Marine Technology

Submission date: June 2017

Supervisor: Svein Aanond Aanonsen, IMT

Co-supervisor: Stein Haugen, IMT

Norwegian University of Science and Technology  
Department of Marine Technology





**NTNU Trondheim**  
**Norwegian University of Science and Technology**  
*Department of Marine Technology*

## **MASTER THESIS IN MARINE DESIGN AND LOGISTICS** **SPRING 2017**

### **Design of a Small Autonomous Passenger ferry**

**Charlotte Hjelmseth Larssen, Christina Torjussen Heggelund & Gina Havdal**

#### **Background**

There are currently three bridges over the channel in Trondheim, yet in the area between Ravnkloa and Fosenkaia there are no possible pedestrian crossings. Trondheim municipality is planning a pedestrian crossing in the area, using a foot bridge. The purpose of the bridge is to provide access for pedestrians, cyclists and tourists. It is a necessity that the foot bridge allows boat traffic in the channel. Three teams of architects have made drafts for the bridge design, but the project is currently put on hold.

Today a traditional rowing boat charters locals and tourists over the channel at Ravnkloa during the summer. Volunteers from Trondheim Coastal Association takes turn rowing the boat. The rowing boat is in only service from May to September during the weekend. The challenge with this service is that it requires a lot of resources to maintain it. There are also strict limitations to the type of passengers the rowing boat can transport. For instance, it cannot transport strollers and wheelchairs. Although a footbridge is an option to transport people over the channel, the Coastal Association wish that the solution maintains this old rowing boat tradition. For that reason, they have presented the idea of an autonomous ferry in the channel. The idea was presented in the spring of 2016 by current project manager Egil Eide. The ferry is intended to continue the tradition of the rowing boat in an innovative way and provide higher availability of the Brattøra area.

#### **Main Objective**

Ship design is a complex process that demands both creativity and analytical skills from the designer. Common practice in ship design is to use the existing fleet as a basis for the design. As there are no autonomous vessels currently on the market, there does not exist any such database for this design project. This type of ship design sets new requirements from the designers that needs to find inspiration from other closely related projects. The main objective of this thesis is to determine the best possible design of an autonomous passenger ferry and document the design process.



**NTNU Trondheim**  
**Norwegian University of Science and Technology**  
*Department of Marine Technology*

### **Scope of work and main activities**

- Describe the relevant theory for design of an autonomous passenger ferry.
- Determine the appropriate design method
- Perform a concept development of vessel design
- Perform a formal safety assessment to review important safety issues
- Perform detail design of ferry by analysing and verifying concepts
- Construct arrangement drawings and specifications for final design
- Document all steps in the process
- Determine if the ferry is a better alternative than a bridge in the area
- State recommendations for further work

### **Modus Operandi**

The thesis will present theory relevant to the main objective. This includes theory on the methods that are to be used, theory on design and on how the aspect of autonomy will affect both the final design and the design process itself. The ferry design is to be determined using the methodology considered appropriate. Possible solutions to the functional requirements, set from the main objective, will be suggested through a brainstorming session. This will be followed by a morphological combination of the solutions suggested to create all possible concepts. Necessary information will be gathered to evaluate the feasibility of the concepts. Using this information, the number of concepts will be limited. The analytical hierarchy process or similar will be used to evaluate the concepts against each other. The best concept will be the one that is further developed into the final design solution. It may be necessary to further develop more than one of the concepts, if the ranking cannot rule out one as the optimal. A new evaluation will then be necessary after further development to limit the work to one design. The detail design of the final solution will be done using the results from the risk assessment combined with analyses on costs, stability and strength. The resistance of the hull will be determined through calculations to further determine the necessary propulsion power. Several iterations may be necessary, each iteration improving the design according to the ongoing evaluations. Once the design is set, arrangement drawings and line drawings will be made. They will provide detailed information on the hull design and the arrangement of equipment on board the vessel. The team will follow NTNU's master thesis guidelines and submit the thesis within the set deadline.

### **Supervision:**

Main supervisor: Svein Aanond Aanondsen

Sub-supervisor: Stein Haugen

**Deadline: 11.06.2017**

---

## Preface

The report at hand is the resulting master thesis of the work performed in the authors' 10th semester of our M.Sc. in Marine Technology. The work has been carried out during the spring of 2017 and is a mandatory part of the Master of Science program at the Norwegian University of Technology and Science (NTNU). The master thesis is equivalent to 30 credits, estimated to approximately 900 working hours. The work has been carried out by a team of three students. The team members are Gina Havdal, Christina Torjussen Heggelund and Charlotte Hjelmseth Larssen. All team members have contributed with a fair share of the work and affected the final dissertation. The individual team members have throughout the project had different responsibilities, while some of the work requires discussions and brainstorming sessions and are therefore performed as a team. There have been weekly meetings with the project supervisor, Svein Aanond Aanondsen, and the team have experienced steady progress throughout the project.

The main objective of this master thesis is to determine the best possible design for an autonomous passenger ferry that is to operate in Trondheim. External conditions for the design were investigated in the preceding project thesis. These results form the basis for the design, together with the new information gathered in this part of the project.

Through the project, several drawings and analyses have been performed, that result in large files that do not fit into the report format. These appendices are included in a separate electronic attachment. These will in the thesis be referred to as appendix F. The design log from the study is not discussed in the thesis, but included in appendix 12 to provide easy overview of the decisions made throughout the study. Certain of the appendices in the report are also included in electronic format to enable the reader to examine them more closely.

---

We would like to thank our primary supervisor Svein Aanond Aanondsen for guidance, feedback and involvement in the work. We would also like to thank our co-supervisor Stein Haugen for guidance on the formal safety assessment. Further, we would like to thank Egil Eide, Sven Ole M. Nicolaysen, Plan B Energy Storage, Svein David Medhaug from the Norwegian Maritime Authority and Sverre Steen for useful input to the project work.

Trondheim, June 9, 2017

Christina T Heggelund  
Christina Torjussen Heggelund

Charlotte H. Larssen  
Charlotte Hjelmseth Larssen

Gina Havdal  
Gina Havdal

---

## Abstract

The main objective of this study is to determine the design of an autonomous ferry to transport people between Ravnkloa and Fosenkaia in Trondheim. It will also be considered whether or not it will be a better solution than a bridge. The operational area of the ferry is limited to the 100 metres stretch between the two docks. The ferry should not require any personnel on board to operate, but it is assumed that a supervisor can oversee the operations from a land base. The surrounding elements of the system was outlined for easy adaptation, but not designed to full detail due to time limitations. The autonomous system itself was not considered directly as it is outside the team members area of expertise.

The work in this thesis follows the System Based Ship Design (SBSD) methodology, combined with the Risk Based Ship Design (RBSD) method. In order to apply both methods simultaneously, they were slightly adapted to fit the design study. A bigger emphasis has been put on the functional analysis in the SBSBD approach. This makes it easier to determine a good solution for the design. The design study initiates with the mission statement, and sets the main functional requirements for the design based on this. Both relevant generic- and safety related functional requirements were set according to the main functions. The safety related functions were determined by performing a formal safety assessment. To reveal all possible solutions to the functional requirements, a brainstorming session was performed. The alternatives were continuously evaluated against relevant framework conditions and the least relevant ones excluded, thus limiting the final solution throughout the design process. The required area and volume on board, determined using model- and life size test, determined the initial main dimensions. The final design was evaluated on technical performance, economy and safety performance. Stability- strength- and resistance calculations were used to verify the design, in addition to determining the life cycle costs (LCC).

The result of this study is the design of an autonomous ferry with electrical power supply and a ramp used for mooring and entrance. The building material is set to be aluminium. The superstructure is semi-open with two broad pillars at both sides supporting the roof. The ferry will dock at piers separated from other docks in the area. One dock is located at Ravnkloa and the other at Fosenkaia. The dock is to be surrounded by a fence to secure

people from falling in the water. An informational poster is located at the dock to inform passengers about relevant safety issues. To enter the ferry, they need to confirm that they have read this information when passing through the registration gates. The registration gates lock off the docking area to the people on the dock. When the ferry is securely docked, the gates open and passengers can board the ferry. Benches are placed on the dock to make the waiting time more pleasant for people. The dock is designed with a pier at one side of the ferry. This supports the ferry against the currents in the channel to reduce the force acting on the ramp mooring. Entry to the dock is done using a gangway. For wheelchair users, an elevator is included on the gangway. A brief specifications table for the resulting design is presented in the table below.

| <b>SPECIFICATIONS - Ellen AuTomine</b> |                                     |
|--|-------------------------------------|
| Vessel type                            | Autonomous passenger vessel         |
| Area of operation                      | Trondheim                           |
| Flag                                   | Norwegian                           |
| Max number of passengers               | 12                                  |
| Number of seats                        | 12                                  |
| Number of bike stands                  | 12                                  |
| Number of wheelchair spaces            | 3                                   |
| Lenght Overall                         | 9 metres                            |
| Beam                                   | 4 metres                            |
| Design draught                         | 0.515 metres                        |
| Displacement                           | 7.610 tonnes                        |
| Main propulsion power source           | 2x PBES 400v, 26kWh battery modules |

The ferry is able to transport all types of pedestrians, and is thus able to substitute a bridge. The weakness of the ferry option is that passengers may need to wait a few minutes to use the ferry. The ferry's life cycle costs were estimated at approximately NOK 2.4 million over 15 years. This is significantly lower than the price tag for the bridge, estimated at NOK 42 million. Thus, the the ferry is considered a good alternative. All functional requirements set to the design are considered fulfilled to a reasonable degree.

The methods applied for the design have weaknesses. Flaws in the RBSD methodology include a lack of accurate statistical information, the fact that the method is based on analysis of existing vessels, and that it is dependent on predetermined risk acceptance criteria. Flaws in the SBSD methodology include non existing statistical information on



---

small and/or autonomous vessels. Required space for all systems was therefore set using existing equipment. Another flaw is that functional requirements may not cover all actual requirements for the vessel. For instance, bollards and ropes are required on board in case towing is necessary, but is not covered by any functional requirements.

The iterative nature of the design process indicate several relevant tasks for the further project work. It will be relevant to consider all aspects set by regulations. New aspects for consideration include design of land based dock systems and determination of access restrictions, required safety level, disclaimer of liability and technical requirements for autonomous vessels. Several aspects on board the vessel are also relevant. This includes heating cables in the ferry roof and main deck, verification of plate thickness, hull adaptation for welding and design of bicycle racks. The operational plan for the battery systems should be determined for the ferry operation to run as smoothly as possible. Finally, the damage stability for the vessel should be verified.



---

## Sammendrag

Hovedmålet med denne oppgaven er å designe en autonom ferge for transport av personer mellom Ravnkloa og Fosenkaia i Trondheim. Det er lagt planer for en bro over kanalen, og det vil derfor bli vurdert om fergen kan være et bedre alternativ enn denne. Operasjonsområdet er begrenset til de 100 meterne mellom de to bryggene. Fergen skal være fullstendig ubemannet, men det er antatt at det til enhver tid vil være en tilsynsmann som kan overvåke fergen fra en landbasert sentral. For å enkelt kunne tilpasse fergedesignet til tilhørende systemer, er disse systemene skissert, men ikke designet i detalj. Fergen ble i størst mulig grad designet for å operere autonomt, men det autonome systemet ble ikke detaljert ettersom det er utenfor gruppens fagfelt.

Metoden brukt i studien var en kombinasjon av systembasert skipsdesign (SBSD) og risikobasert skipsdesign (RBSD). De to metodene er noe modifisert for å enkelt kunne tilpasses hverandre i designprosessen. Blant annet ble det lagt større fokus på funksjonsanalyse i SBSBD-metodikken. Dette for å finne en god løsning for designet. Designprosessen starter ved å definere formålet med designet, før hovedfunksjonene for designet fastsettes. Både relevante generiske- og sikkerhetsrelaterte funksjoner ble satt ut fra hovedfunksjonen. Sikkerhetsrelaterte funksjonskrav ble videre satt på bakgrunn av en formell sikkerhetsanalyse (Formal Safety Assessment). Det ble gjennomført en idémyldring for å finne mulige løsninger som tilfredstiller de funksjonelle kravene. Alternativene ble vurdert opp mot de relevante rammevilkårene. Antall løsninger ble redusert ved at de minst relevante alternativene ble eliminert underveis. Som et utgangspunkt for å fastsette hoveddimensjonene ble areal- og volumbehov undersøkt gjennom modell- og fullskalatester. Det ferdige designet har blitt evaluert på grunnlag av teknisk ytelse, økonomi og sikkerhet. For å verifisere designet ble det brukt stabilitets-, styrke-, og motstandsberegninger, i tillegg til beregning av livssyklus kostnader.

Resultatet av oppgaven er en autonom ferge i aluminium med elektrisk drift. Overbygget på ferga er semi-åpent med to brede søyler på hver side som bærer taket. Ferga skal fortøyes ved hjelp av en spesialtilpasset rampe, som også skal brukes for av- og påstigning. Ferga skal ha sin egen brygge, en i Ravnkloa og en på Fosenkaia. Brygga skal være inngjerdet for å forhindre at passasjerer faller i vannet. Informasjon og sikkerhetsinstruksjoner for ferga vil kunne leses på et informasjonsskilt på brygga, og for å kunne gå om

bord i ferga må man bekrefte at man aksepterer den oppgitte informasjonen. Når fergen har lagt til kai og er fortøyd vil det være mulig å gå gjennom portene for å entre ferga. Det vil være benker på brygga for å gjøre ventingen mer komfortabel. Etersom det er strøm i kanalen som vil sette krav til styrken i rampefortøyningen, er det lagt til en smal pir på brygga som ferga skal ligge inntil. For at passasjerene skal komme seg ned til brygga er det bygd en landgang. Etersom denne kan være for bratt for rullestolbrukere, er en rullestolheis montert på landgangen. En kort spesifikasjon er vist i tabellen under.

| <b>SPESIFIKASJONER - Ellen AuTomine</b> |                                    |
|---|------------------------------------|
| Fartøystype                             | Autonom passasjerferge             |
| Operasjonsområde                        | Trondheim                          |
| Flaggstat                               | Norge                              |
| Max antall passasjerer                  | 12                                 |
| Antall seter                            | 12                                 |
| Antall sykkelstativ                     | 12                                 |
| Antall rullestolplasser                 | 3                                  |
| Største lengde (LOA)                    | 9 meter                            |
| Bredde                                  | 4 meter                            |
| Designdypgang                           | 0.515 meter                        |
| Deplasement                             | 7.610 tonn                         |
| Fremdriftssystem                        | 2x PBES 400v, 26kWh Batterimoduler |

Ferga er designet for å frakte alle passasjerkategoriene som broa er planlagt for. Fergen kan derfor erstatte en bro i området. En svakhet med fergen vil være eventuell ventetid mellom avgangene. Livssyklus kostnaden er beregnet til å være NOK 2.4 millioner over 15 år. Dette er betydelig lavere enn kostnaden for broen, som er antatt å være NOK 42 millioner. Alle funksjonskravene som er satt for designet ansees å være tilfredsstillt.

Det er flere svakheter ved metodene som er brukt. Svakheter ved RBSD inkluderer mangel på statistisk informasjon i risikoanalysen, det faktum at metoden egentlig er basert på analyser av eksisterende fartøy og at den er avhengig av forhåndsbestemte risikokriterier. Svakheter i SBSB inkluderer mangelen på statistisk informasjon for små og/eller autonome fartøy. Hele analysen er derfor gjort på bakgrunn av informasjon om eksisterende utstyr. En annen svakhet er at enkelte krav ikke vil være inkludert i funksjonskravene. Et eksempel er kravet om pullerter og tau ombord for tauing. Dette er ikke inkludert i funksjonskravene for fergen.

---

Grunnet designprosessens iterative natur vil det være flere aspekter ved designet som kan forbedres. Det vil være nødvendig å vurdere relevante forskrifter nøyere, og sørge for at alle krav er tilfredsstilt. Videre arbeid inkluderer også design av de bryggerelaterte systemene med fokus på brukerbegrensninger, nødvendig sikkerhetsnivå, ansvarsfraskrivelse og tekniske krav til autonome fartøyer. For selve ferga er det nyttig å se videre på varmekabler i hoveddekk og tak, verifisering av platetykkelse, skrogendringer i forhold til byggetekniske forhold og utforming av sykkelstativ ombord. Det må settes en driftsprofil for batteriene for å sikre en mest mulig effektiv drift. Skadestabiliteten bør også verifiseres.



# Table of Contents

|  |           |
|--|-----------|
| Preface  | i         |
| Abstract   | iii       |
| Sammendrag   | vi        |
| List of Figures  | xiv       |
| List of Tables   | xvi       |
| Acronyms   | xvii      |
| <b>1 Introduction</b>                                      | <b>1</b>  |
| 1.1 Objective . . . . .                                    | 2         |
| 1.2 Previous Work and Current Status . . . . .             | 2         |
| 1.3 Future Developments . . . . .                          | 3         |
| 1.4 Report Structure Overview . . . . .                    | 5         |
| <b>2 Framework Conditions</b>                              | <b>7</b>  |
| 2.1 Weather and Metocean Data . . . . .                    | 7         |
| 2.2 Restrictions Related to the Operational Area . . . . . | 8         |
| 2.3 Relevant Rules and Regulations . . . . .               | 9         |
| <b>3 Theoretical Background</b>                            | <b>11</b> |
| 3.1 Design Methods . . . . .                               | 11        |
| 3.1.1 The Generic Design Method . . . . .                  | 11        |
| 3.1.2 The Traditional Marine Design Method . . . . .       | 14        |
| 3.1.3 The System Based Ship Design Method . . . . .        | 15        |
| 3.1.4 The Risk Based Ship Design Method . . . . .          | 18        |
| 3.1.5 Risk Assessment for the RBSD Method . . . . .        | 20        |
| 3.2 Methods for Evaluation of Design and Ideas . . . . .   | 28        |
| 3.2.1 Methods for Ranking of Alternatives . . . . .        | 28        |
| 3.2.2 Life Cycle Cost . . . . .                            | 29        |
| 3.3 Additional Relevant Theory . . . . .                   | 30        |

---

|          |  |            |
|----------|--|------------|
| 3.3.1    | Definition and Levels of Autonomy . . . . .                      | 30         |
| 3.3.2    | Vessel Resistance . . . . .                                      | 34         |
| 3.3.3    | Vessel Stability . . . . .                                       | 37         |
| 3.3.4    | Technical Drawings . . . . .                                     | 40         |
| <b>4</b> | <b>Methodical Approach</b>                                       | <b>43</b>  |
| 4.1      | Determination of Design Method . . . . .                         | 43         |
| 4.2      | Description of Methodical Approach . . . . .                     | 44         |
| <b>5</b> | <b>Mission Statement and Functional Requirements</b>             | <b>49</b>  |
| 5.1      | Mission Statement and Main Functions . . . . .                   | 49         |
| 5.2      | Safety Related Functions . . . . .                               | 50         |
| 5.3      | Formal Safety Assessment . . . . .                               | 51         |
| 5.3.1    | Hazard Identification . . . . .                                  | 51         |
| 5.3.2    | Identification of Critical Design Scenarios . . . . .            | 53         |
| 5.3.3    | Risk Control Options . . . . .                                   | 55         |
| 5.3.4    | Cost Benefit Analysis . . . . .                                  | 56         |
| 5.3.5    | Safety Related Functional Requirements . . . . .                 | 58         |
| <b>6</b> | <b>Concept Development</b>                                       | <b>59</b>  |
| 6.1      | Functional Analysis and Possible Solutions . . . . .             | 59         |
| 6.2      | Determination of Hull Shape . . . . .                            | 63         |
| 6.3      | Determination of Docking Approach . . . . .                      | 68         |
| 6.4      | Determination of Mooring System . . . . .                        | 71         |
| 6.5      | Safety Considerations . . . . .                                  | 74         |
| 6.6      | Autonomy Considerations . . . . .                                | 77         |
| 6.7      | Design of Dock Layout . . . . .                                  | 82         |
| 6.8      | Estimation of the Required Area on Main Deck . . . . .           | 87         |
| 6.8.1    | Life-Size Experiment . . . . .                                   | 88         |
| 6.8.2    | Model-Size Experiment . . . . .                                  | 94         |
| 6.9      | Initial Estimation of Required Volume and Displacement . . . . . | 106        |
| <b>7</b> | <b>Detail Design</b>   | <b>111</b> |
| 7.1      | Development of 3D Model . . . . .                                | 111        |



---

|           |   |            |
|-----------|---|------------|
| 7.2       | Design of Superstructure . . . . .                            | 115        |
| 7.3       | Re-evaluation of Power Supply . . . . .                       | 120        |
| 7.4       | Revision of Required Volume and Displacement . . . . .        | 122        |
| 7.5       | Initial Arrangement Below Deck . . . . .                      | 130        |
| <b>8</b>  | <b>Verification of Design</b>                                 | <b>133</b> |
| 8.1       | Assessment of the Stability and Strength . . . . .            | 133        |
| 8.2       | Assessment of Resistance . . . . .                            | 142        |
| 8.3       | Technical Drawings . . . . .                                  | 144        |
| 8.3.1     | General Arrangement . . . . .                                 | 145        |
| 8.3.2     | Loading Condition Examples . . . . .                          | 148        |
| 8.3.3     | Lines Plan . . . . .  | 151        |
| 8.3.4     | Midship Section . . . . .                                     | 152        |
| 8.3.5     | System Illustration Drawings . . . . .                        | 152        |
| 8.3.6     | One-line Diagram . . . . .                                    | 158        |
| 8.3.7     | Firefighting Scheme . . . . .                                 | 158        |
| 8.4       | Calculation of Life Cycle Costs . . . . .                     | 159        |
| <b>9</b>  | <b>Results</b>  | <b>163</b> |
| <b>10</b> | <b>Discussion</b>   | <b>167</b> |
| 10.1      | Evaluation of the Result . . . . .                            | 167        |
| 10.2      | Performance with Regards to Functional Requirements . . . . . | 168        |
| 10.3      | Restriction of Passenger Groups . . . . .                     | 170        |
| 10.4      | Emergency Plan and Information . . . . .                      | 171        |
| 10.5      | Evaluation of the Design Approach . . . . .                   | 172        |
| 10.6      | The Iterative Nature of the Design Process . . . . .          | 174        |
| <b>11</b> | <b>Further Work</b>   | <b>175</b> |
| 11.1      | Improve the Current Design . . . . .                          | 175        |
| 11.2      | New Aspects for Consideration . . . . .                       | 176        |
| <b>12</b> | <b>Conclusion</b>   | <b>181</b> |
|           | <b>Bibliography</b>   | <b>185</b> |

|  |               |
|--|---------------|
| <b>A Appendix: Design Log</b>  | <b>I</b>      |
| <b>B Appendix: Formal Safety Assessment</b>                            | <b>IV</b>     |
| B.1 Notes from Preparation of PHA . . . . .                            | IV            |
| B.2 Mindmaps from Brainstorming for Risk Assessment . . . . .          | VI            |
| B.3 Fault Tree Analysis . . . . .                                      | XII           |
| B.4 FTA - Values for Basic Events . . . . .                            | XXVIII        |
| B.5 Cost Benefit Analysis . . . . .                                    | XXX           |
| <b>C Appendix: Concept Development</b>                                 | <b>XLII</b>   |
| C.1 Concepts to Transport Passengers over the Channel . . . . .        | XLII          |
| C.2 Eliminated solutions . . . . .                                     | XLIII         |
| C.3 Hull Shape Sketches . . . . .                                      | XLV           |
| C.4 Sketches of Mooring Alternatives . . . . .                         | LII           |
| C.5 Sketch of Gangway Solution . . . . .                               | LVI           |
| C.6 Dock Area at Ravnkloa and Fosenkaia . . . . .                      | LVII          |
| C.7 SBSB Version 1 and 2 . . . . .                                     | LVIII         |
| C.8 Power Demand of Propulsion System Based on Torqueedo Pod . . . . . | LXXXIII       |
| <b>D Appendix: Hull and Superstructure</b>                             | <b>LXXXIV</b> |
| D.1 Starting plate in Delftship . . . . .                              | LXXXIV        |
| D.2 Model With and Without Raised Bow . . . . .                        | LXXXIV        |
| D.3 Hull Profile in Delftship . . . . .                                | LXXXV         |
| D.4 Curved Surface . . . . .   | LXXXV         |
| D.5 Sketches of Superstructure Designs . . . . .                       | LXXXVI        |
| D.6 Notes from Meeting with PBES . . . . .                             | XCII          |
| D.7 Calculation of Novec Amount for Fire Fighting . . . . .            | XCIV          |
| D.8 Anchor Dimensions set by Nordic Boat Standard . . . . .            | XCVI          |
| D.9 Sketches of Arrangement Below Deck . . . . .                       | XCVII         |
| <b>E Appendix: Validation of design</b>                                | <b>C</b>      |
| E.1 Simplified Strength Requirements . . . . .                         | C             |
| E.2 Design Hydrostatics Report without Ballast . . . . .               | CI            |
| E.3 Design Hydrostatics Report with 750 kg Ballast . . . . .           | CIII          |

|          |   |                |
|----------|---|----------------|
| E.4      | Extract from Stability Reports . . . . .  | CV             |
| E.5      | Moment curves . . . . .                   | CIX            |
| E.6      | Strength Calculations . . . . .           | CXII           |
| E.7      | Strength Calculations in Matlab . . . . . | CXIV           |
| E.8      | Results from ShipX . . . . .              | CXV            |
| E.9      | Resistance Calculations . . . . .         | CXX            |
| E.10     | Life Cycle Cost Calculation . . . . .     | CXXV           |
| <b>F</b> | <b>Appendix: Electronic Files</b>         | <b>CXXXVII</b> |



## List of Figures

|    |  |    |
|----|--|----|
| 1  | Illustration of the operational area (Norgeskart, 2016) . . . . .                        | 8  |
| 2  | The five phases of the design, modelled after figure in Endal et al. (2011) .            | 12 |
| 3  | Design spiral describing the generic design process (Aanondsen, 2017) . . .              | 14 |
| 4  | Design Spiral describing the marine design process (Evans, 1959) . . . . .               | 15 |
| 5  | Design spiral describing the SBSB process (Erikstad and Levander, 2012) .                | 16 |
| 6  | Example illustrating a functional analysis (Jakobsen, 1990) . . . . .                    | 17 |
| 7  | Risk matrix illustrating the risk levels (Rausand, 2013) . . . . .                       | 24 |
| 8  | The bow-tie model, modelled after figure in Rausand (2013). . . . .                      | 26 |
| 9  | Generic example of a GZ curve . . . . .  | 38 |
| 10 | Example of GZ curve including arm of heeling moment . . . . .                            | 40 |
| 11 | Illustration of the SBSB method combined with the RBSB . . . . .                         | 45 |
| 12 | The combined SBSB-RBSB methodology used in this thesis . . . . .                         | 47 |
| 13 | Possible solutions after elimination round one in morphological combination              | 60 |
| 14 | Possible solutions after elimination round one in morphological combination              | 61 |
| 15 | Possible solutions for how to dock the ferry . . . . .                                   | 69 |
| 16 | Sketches of possible ramp concepts for mooring . . . . .                                 | 73 |
| 17 | Possible locations for sensor on a ferry roof . . . . .                                  | 79 |
| 18 | Illustration of the placement of the docks at Ravnkloa and Fosenkaia . . .               | 83 |
| 19 | Possible dock layout concepts . . . . .  | 84 |
| 20 | Possible dock layout as suggested by the EiT team (Engebakken et al.,<br>2017) . . . . . | 84 |
| 21 | Illustration of final dock layout concept . . . . .                                      | 86 |
| 22 | Loading condition A and B in life-size testing . . . . .                                 | 89 |
| 23 | Loading condition C in life-size testing . . . . .                                       | 90 |
| 24 | Loading condition D and E in life-size testing . . . . .                                 | 91 |
| 25 | Loading condition F in life-size testing . . . . .                                       | 92 |
| 26 | Loading condition G and H in life-size testing . . . . .                                 | 93 |
| 27 | Loading condition H in life-size testing . . . . .                                       | 94 |
| 28 | Model testing scenarios 1,2,3 and 4 . . . . .  | 96 |
| 29 | Model testing scenarios 5,6,7 and 8 . . . . .  | 98 |
| 30 | Model testing scenarios 9 and 10 . . . . .   | 99 |

---

|    |   |     |
|----|---|-----|
| 31 | Model testing scenarios 11,12 and 13 . . . . .  | 100 |
| 32 | Model testing scenarios 14 and 15 . . . . .   | 101 |
| 33 | Model testing scenarios 16, 17 and 18 . . . . .   | 102 |
| 34 | Model testing scenarios 19 and 20 . . . . .   | 103 |
| 35 | Model testing scenarios 21, 22, 23 and 24 . . . . .   | 104 |
| 36 | Model testing scenario 25 . . . . .   | 105 |
| 37 | Illustration of initial hull shape . . . . .  | 112 |
| 38 | Illustration of final hull model . . . . .  | 113 |
| 39 | Illustration of midship sections . . . . .  | 113 |
| 40 | Plot illustrating curvature on hull, red implying double curvature . . . . .                | 114 |
| 41 | Concept suggestions to semi- open superstructure . . . . .                                  | 118 |
| 42 | Illustration of the final design of the superstructure . . . . .                            | 119 |
| 43 | Illustration of the vessel using different ramp designs . . . . .                           | 120 |
| 44 | Illustration of battery module delivered by PBES (Plan B Energy Storage,<br>2017) . . . . . | 125 |
| 45 | Resulting arrangement of the rooms below deck, figure from Delftship . . .                  | 131 |
| 46 | Illustration of cross section with structural elements . . . . .                            | 134 |
| 47 | Illustration of structural elements . . . . .   | 135 |
| 48 | Plot of load- and weight distribution at design load . . . . .                              | 140 |
| 49 | Plot of bending moment at design load . . . . .   | 141 |
| 50 | Total resistance for the vessel according to speed . . . . .                                | 143 |
| 51 | Illustration of foldable chair . . . . .  | 147 |
| 52 | Illustration of all passenger groups on board . . . . .                                     | 149 |
| 53 | Illustration of 12 bicycles placed in the bicycle racks . . . . .                           | 150 |
| 54 | Illustration of 11 bicycles not in bicycle racks, and one wheelchair . . . . .              | 150 |
| 55 | Illustration of bicycles placed in an unorganized fashion . . . . .                         | 150 |
| 56 | Illustration of design load case . . . . .  | 151 |
| 57 | System illustration drawing of bilge system . . . . .                                       | 153 |
| 58 | System illustration drawing of fire fighting system below deck . . . . .                    | 154 |
| 59 | System illustration drawing of ramp mooring system . . . . .                                | 156 |
| 60 | System illustration drawing of navigational light system . . . . .                          | 157 |
| 61 | The Resulting Ferry Design . . . . .  | 163 |

## List of Tables

|    |  |     |
|----|--|-----|
| 1  | PHA worksheet . . . . .  | 24  |
| 2  | NHTSA’s hierarchy of automation levels (Anderson et al., 2014) . . . . .                                 | 32  |
| 3  | Lloyd’s Registers’s hierarchy of automation levels for ships (Lloyd’s Register, 2016) . . . . .          | 33  |
| 4  | Description of frequency categories used in the PHA . . . . .  | 52  |
| 5  | Description of consequence categories used in the PHA . . . . .  | 53  |
| 6  | Hazardous events in the unacceptable region . . . . .  | 54  |
| 7  | Probability categories used for FTA . . . . .  | 54  |
| 8  | Possible alternative risk control measures . . . . .   | 55  |
| 9  | Summary of the result from the cost benefit analysis . . . . .   | 57  |
| 10 | Remaining solutions to the functional requirements after elimination round 2                             | 61  |
| 11 | Remaining solutions to the functional requirements after elimination round 3                             | 63  |
| 12 | Ranking of hull shape alternatives . . . . .   | 65  |
| 13 | Ranking of alternatives on how to dock . . . . .   | 70  |
| 14 | Description of loading conditions - Life size testing . . . . .  | 88  |
| 15 | Loading conditions presented as scenarios - Model size testing . . . . .                                 | 95  |
| 16 | Calculation of ferry power demand for one year, based on 2.5 kW power demand for speed of 4 kn . . . . . | 108 |
| 17 | Ranking of superstructure alternatives . . . . .   | 115 |
| 18 | Summary of the amount Novec 1230 used for fire extinguishing . . . . .                                   | 127 |
| 19 | Plate thickness for elements in the structure . . . . .  | 133 |
| 20 | Description of loading conditions tested in stability analysis . . . . .                                 | 137 |
| 21 | Summary of results from the strength calculations . . . . .  | 142 |
| 22 | The LCC for the autonomous ferry . . . . .   | 160 |
| 23 | The LCC for the total system consisting of the dock and autonomous ferry                                 | 160 |
| 24 | Vessel specification table . . . . .   | 164 |





## Acronyms

**ALARP** as low as reasonably practicable. 23

**AUV** Autonomous Underwater Vehicle. 2

**CBA** Cost Benefit Analysis. 27

**DF** Disproportionality factor. 27

**DP** Dynamic Positioning. 60

**EiT** Experts in Teamwork. 83

**ETA** Event Tree Analysis. 19

**FMEA** Failure Modes and Effects Analysis. 19

**FSA** Formal Safety Assessment. 21

**FTA** Fault Tree Analysis. 19

**GA** General Arrangement. 41

**GHG** Greenhouse Gas. 62

**HAZID** Hazard Identificaton Study. 19

**HAZOP** Hazard and Operability Study. 19

**IC** internal combustion. 62

**IMO** International Maritime Organisation. 18

**LCC** Life Cycle Cost. 29

**MUNIN** Maritime Unmanned Navigation through Intelligence in Networks. 3

- NBS** Nordic Boat Standard. 9
- NFAS** Norwegian Forume for Autonomous Ships. 4
- NHTSA** National Highway Traffic Safety Administration. 3
- NTNU** Norwegian University of Science and Technology. 3
- PHA** Preliminary Hazard Analysis. 22
- RBSD** Risk Based Ship Design. 18
- RCM** Risk Control Measure. 21
- RCO** Risk Control Option. 21
- RCT** Risk Contribution Tree. 21
- RPN** Risk Priority Number. 23
- SBSD** System Based Ship Design. 15
- SWIFT** Structures What If Technique. 19
- USV** Unmanned Surface Vehicle. 3

# 1 Introduction

Trondheim is the third most populous municipality in Norway, and commonly known as the capital of technology (Statistics Norway, 2016). A channel, connected to the river Nidelva, separates the city centre from the facilities located nearby, at Brattøra. This includes both the speed boat terminal, the central station, hotels and other facilities. Trondheim municipality is interested in a new pedestrian crossing over the channel in the Ravnkloa area. Plans for building a bridge, crossing the channel from Ravnkloa to Fosenkaia, were made. A related project named "Hjertepromenaden" also envision a bridge in the area as they wish to form a hiking trail following the river and channel around the city centre (Hjerteplanen, 2017). The estimated price tag for this bridge is NOK 42 million (Svaan, 2012). The project is currently put on hold.

There used to be a bridge crossing the channel in the area. It was demolished in 1920, most likely because it was a hurdle for the traffic in the channel. For the past 120 years, there has also been a rowing boat available to transport people across the channel for a small fee. This service is provided by Trondheim Coastal Association. The rowing boat is only available during the summer months and at specific times. This is because it is operated by members of the Coastal Association on a voluntary basis. An economical alternative that will preserve this tradition and operate all year round is therefore sought after by the Coastal Association.

Leader of the Coastal Association in Trondheim, Egil Eide, was the initiator of using a different solution than the bridge. This to avoid the bridge, as it would both interfere with boat traffic in the channel and possibly impose significant operational costs. A conventional ferry would not be a good alternative as the operational costs are too high, having to pay for a captain on board. Eide therefore suggested using a small autonomous ferry to transport passengers across the channel. An autonomous ferry, requiring no on-board personnel, could possibly prove a better alternative to the bridge, reducing the operational costs of the crossing. It could also prove a positive addition to the city, known as the Norwegian capital of technology. Trondheim municipality have shown interest in the project and the harbour manager wish to investigate the possibility that the harbour staff could take responsibility of the ferry's daily operation. He believes this could be useful training for them to learn how to handle larger autonomous vessels (Eide, 2017).

## 1.1 Objective

The main objective of this study is to determine the design of an autonomous ferry to transport pedestrians between Ravnkloa and Fosenkaia in Trondheim. It will also be considered whether or not it will be a better solution than a bridge.

The operational area of the ferry is limited to the 100 meter stretch between the two docks. The ferry should not require any personnel on board to operate, but it is assumed that a supervisor can oversee the operations from a land base. The surrounding elements of the system will be outlined for easy adaptation, but not designed to full detail due to time limitations. The autonomous system itself will not be considered directly as it is outside the team members area of expertise. A separate project, designing this system is undertaken at the Department of Engineering Cybernetics at NTNU, in parallel with this thesis.

## 1.2 Previous Work and Current Status

There are today no fully autonomous vehicles available on the market, neither land based nor in marine transportation. The autonomous land vehicle development has reached further than for ships. Research is currently undertaken for further developments within both fields. Autonomous cars and buses have been tested multiple times on the roads and show good results (Teknisk Ukeblad, 2015). Germany recently made it legal to use autonomous cars on public roads securing that regulations are established in the near future (Teknisk Ukeblad, 2017). Autonomous features are available on commercial cars, such as automatic parallel parking (Teknisk Ukeblad, 2015). In the naval sector, vessels are still in the development phase and no full scale vessels have yet been tested in busy waters. The product available in the naval sector with the highest degree of autonomy is the Autonomous Underwater Vehicle (AUV). It may provide a good basis for further developments, but do not possess all required qualities. As they operate underwater in controlled environments they do not need to account for moving traffic like a ship would need to. A test area in the Trondheim Fjord was opened in September 2016, to enable research and testing of autonomous vessels. It is the first test area for autonomous ships in the world and may contribute in defining relevant requirements for the regulations, getting

them in place as soon as possible. The test area is organized by Marintek, Kongsberg Seatex, Kongsberg Maritime, Trondheim Port, Maritime Robotics and NTNU (Gemini, 2016). Both Marintek, Kongsberg and Maritime Robotics have also initiated their own projects to develop autonomous ship systems. Maritime Robotics have developed, among other things, an Unmanned Surface Vehicle (USV) called the Wave Glider. This is used to gather weather data from areas previously too expensive to map (Maritime Robotics, 2017). (Gemini, 2016)

The Maritime Unmanned Navigation through Intelligence in Networks (MUNIN) project examines the barriers in communication between the autonomous vessel and the land base (MUNIN, 2017). Their goal is to develop and verify a concept for an autonomous ship. Several other reports discuss the same challenge that they face. The report *Communication Architecture for an Unmanned Merchant Ship* examines the requirements for the communication systems on board the autonomous vessel (Rødseth et al., 2013). The report *Autonomous Ship Collision Avoidance Navigation Concepts, Technologies and Techniques* looks at the system for autonomous control of a vessel. It considers using artificial intelligence methods to avoid collision (Statheros et al., 2008). None of the reports focus on the actual process of designing the ship itself or the totality of the autonomous ship.

No recent master thesis is available at NTNU focusing on a marine design process. Nor are there any similar passenger ferries on the market of this scale. There are however, several articles on systems for autonomous navigation. In relation to the project that this master thesis is part of, a five metres long prototype ferry was designed by John Boye Andersen in cooperation with Egil Eide. This will be used to test the autonomous system and its functionality to optimize it for its tasks. The results from the testing will be valuable for the further work, but is unfortunately not available until after the thesis due date.

### 1.3 Future Developments

Several companies are currently working on defining the different levels of autonomy. Both Lloyd's Register and the National Highway Traffic Safety Administration (NHTSA) have stated their own definition of autonomy and levels of autonomy. Lloyd's Register's definition applies to ships, while the NHTSA definition is generic but based on land based

vehicles. These definitions will be important in defining the rules and regulations regarding autonomous ships. A fully autonomous vessel will have no captain or crew on board. This implies challenges related to passenger safety, technical aspects and compliance with rules and regulations. There are currently no rules available that determines the requirements for these types of vessels. The Norwegian Maritime Authority is actively involved in the development of such regulations. They have put together a project team that focus on autonomous ships. With input from relevant companies and shipbuilders, they will over time form the rules and regulations that will apply to the future autonomous fleet (Medhaug et al., 2017).

Development of autonomous vessels are a high priority for several marine companies. As no fully autonomous vessel is available on the market, there is a race to release the first reliable design. Both Kongsberg Maritime (Kongsberg, 2017), Rolls Royce (Rolls Royce, 2017) and Wärtsilä (Wartsila, 2017) are working on possible designs. DNV GL are also involved with their new concept vessel ReVolt that is to operate autonomously and have zero emissions(DNV GL, 2017). Norway also have a forum specifically related to autonomous ships, Norwegian Forume for Autonomous Ships (NFAS). This forum is for people and organizations who are interested in autonomous ships and developments within this field. NFAS works to ensure that Norway will be a leading nation in development of autonomous ships. They also wish to ensure the safety of the crew and passengers on board such vessels, as well as control possible cyber threats. (NFAS, 2016)

Finally, Tønsberg municipality is working on a project similar to the project discussed in this thesis. They have sent out an invitation to tender, wanting relevant suppliers to provide them with possible solutions. They also held a conference, together with The Confederation of Norwegian Enterprise, gathering suppliers, designers and class companies to discuss relevant challenges related to autonomous vessels. The team participated in this conference December 2016, learning about relevant challenges to the design, as well as presenting the market research results from the preceding project thesis. The sailing distance and target group in Tønsberg are similar to this project and both parties may thus benefit from each others developments. Project manager of the project in this study therefore intends to keep in contact with them (Eide, 2017).

## 1.4 Report Structure Overview

The reader should make note that the references are done differently for paragraphs where only one source is relevant. In these cases, the reference is listed at the end of the paragraph. This is done to avoid referencing every sentence in a paragraph and improve readability. In addition, two of the appendices have separate reference lists since certain references are used only here. All references used that are not books or scientific articles available online are included in the electronic attachments as pdf files. This is to secure that the information from relevant web sites can be viewed as they were when the thesis was written.

Since a design process is iterative and difficult to organize, the chapters are designed to follow the progress of the work to the extent possible. For this reason, the layout of the chapters differ from a typical scientific report presenting the methodical approach and the results in separate chapters. Here, the methodical approach will be briefly explained before the detailed description is presented together with the results. The reason for this is that relevant results are achieved at different steps in the process. The results achieved in one step is essential in determining the next step of the process. The results chapter will therefore contain a summation of all relevant results instead of presenting new information like in conventional scientific reports. The chapters describing the approach in detail will also contain discussions, despite this normally being isolated in a separate chapter. The thesis will be structured as follows:

**Chapter 2: Framework Conditions** The chapter will describe the relevant framework conditions for the design. This includes weather- and metocean data, rules and regulations and limitations set by the operational area.

### **Chapter 3: Theoretical Background**

The chapter will discuss relevant theory and methods. It will provide the reader with the necessary information to better understand the design process and verification methods. This includes theory on ship design methods, Formal Safety Assessment, verification techniques and other relevant theory.

**Chapter 4: Methodical Approach**

This chapter will provide the reader with an overview of the progression of the work. It will discuss the choice of methodical approach, as well how this approach is applied in the study.

**Chapter 5: Mission Statement and Functional Requirements**

The chapter will define the mission statement and main functional requirements for the project. The safety related functional requirements will be determined using a formal safety assessment.

**Chapter 6: Concept Development**

This chapter will discuss the concept development, leading to the first initial design. The chapter will describe the initial functional analysis, the process of choosing hull shape, the safety- and autonomy considerations and the choice of dock layout and mooring system. In addition, the required area and volume on board will be investigated and determined.

**Chapter 7: Detail Design**

This chapter will describe the process of developing the detailed ferry design. It will present the 3D model of the vessel, the superstructure design, relevant changes made to the initial concept and the initial arrangement.

**Chapter 8: Verification of Design**

In this chapter, the investigations used to verify the design will be addressed. This includes stability- and strength calculations and resistance calculations. The general arrangement and other drawings will be discussed as the final arrangement is set. Finally, the life cycle cost of the vessel will be determined.

**Chapter 9: Results**

This chapter will summarize the results from the study. The most important results will be presented in a specifications table.

**Chapter 10, 11 and 12: Discussion, Further Work and Conclusion**

Chapter 10 will discuss relevant aspects of the study and its results. Chapter 11 will describe what further work is relevant for the thesis. Recommendations are made about what tasks to prioritize. Finally, chapter 12 will present the relevant conclusions drawn from the study.



## 2 Framework Conditions

The Framework conditions will set the requirements and limitations to the design. The project thesis, carried out prior to this master thesis, focused on revealing the relevant framework conditions for the ferry design. These will be presented in this chapter, along with new information from this thesis work.

The relevant framework conditions include among others a requirement that the ferry is more than eight metres long. This is to make sure that passengers do not need to wear life jackets for the crossing. It may have been possible to get an exemption from this rule, but approval from the Norwegian Maritime Authority would be necessary. Further, the ferry should be applicable to wheelchair users and thus have a universal design. It should also be able to transport twelve bicycles in addition to the twelve passengers. Initiating this thesis, the head of the harbour expressed his optimism to the project, positive to discuss the possibility of his employees taking the responsibility of overseeing the operations. It was therefore assumed that a supervisor would be available for the ferry.

### 2.1 Weather and Metocean Data

The project thesis revealed that the ferry will need to be able to withstand temperature extremes between  $-25\text{ }^{\circ}\text{C}$  and  $+30\text{ }^{\circ}\text{C}$ , and wind strengths up to  $18.5\text{ m/s}$ . The ferry- and dock system will also need to account for up to  $3.50$  metres of difference in water level (Havdal et al., 2016). This will mostly affect the dock system, but may also affect the currents in the channel. These will be strongest in the area where the channel and the river Nidelva meets, with strength up to  $0.5\text{ m/s}$  (Norsk Geotekniske Institutt, 2014). No clear information was available on the area in Ravnkloa, and it was assumed to have similar conditions. The report from the project *Renere Havn* in Trondheim, providing info on the currents in the channel, also revealed that the direction of the current is from Brattørbrua to Skansenløpet. This means that when the ferry is moving from Ravnkloa to Fosenkaia, the current will hit its starboard side. The depth of the water in the channel is minimum  $1.7$  metres in relevant areas (Havdal et al., 2016), as can be seen in figure 1.

## 2.2 Restrictions Related to the Operational Area

The geographical layout of the operational area also sets requirements to the project. Figure 1 shows the the area with relevant information marked with numbers. The ferry is to cross between Ravnkloa (1 in figure 1) and Fosenkaia (2). Other vessels traffic the area, and there are other docks to take into account when deciding the placement of the ferries route and docks. The dock of the vessel that travels to Munkholmen is located at Ravnkloa (3). This dock is also used by fishing vessels, selling fish at the dock. There are also privately owned docks along this side of the channel, where recreational boats dock (4). Ravnkloa is centrally located and is connected to the city centre, making it a busy area. The upper part of the figure show Vestre Kanalkai (5) and Fosenkaia (2). At Fosenkaia, Trondheim Coastal Association have docks for their vintage boats (6). There is also a culvert under the railroad at Fosenkaia (7), leading to the pier at Brattøra and the facilities that are located there. It is also a short walk away from the railway station.

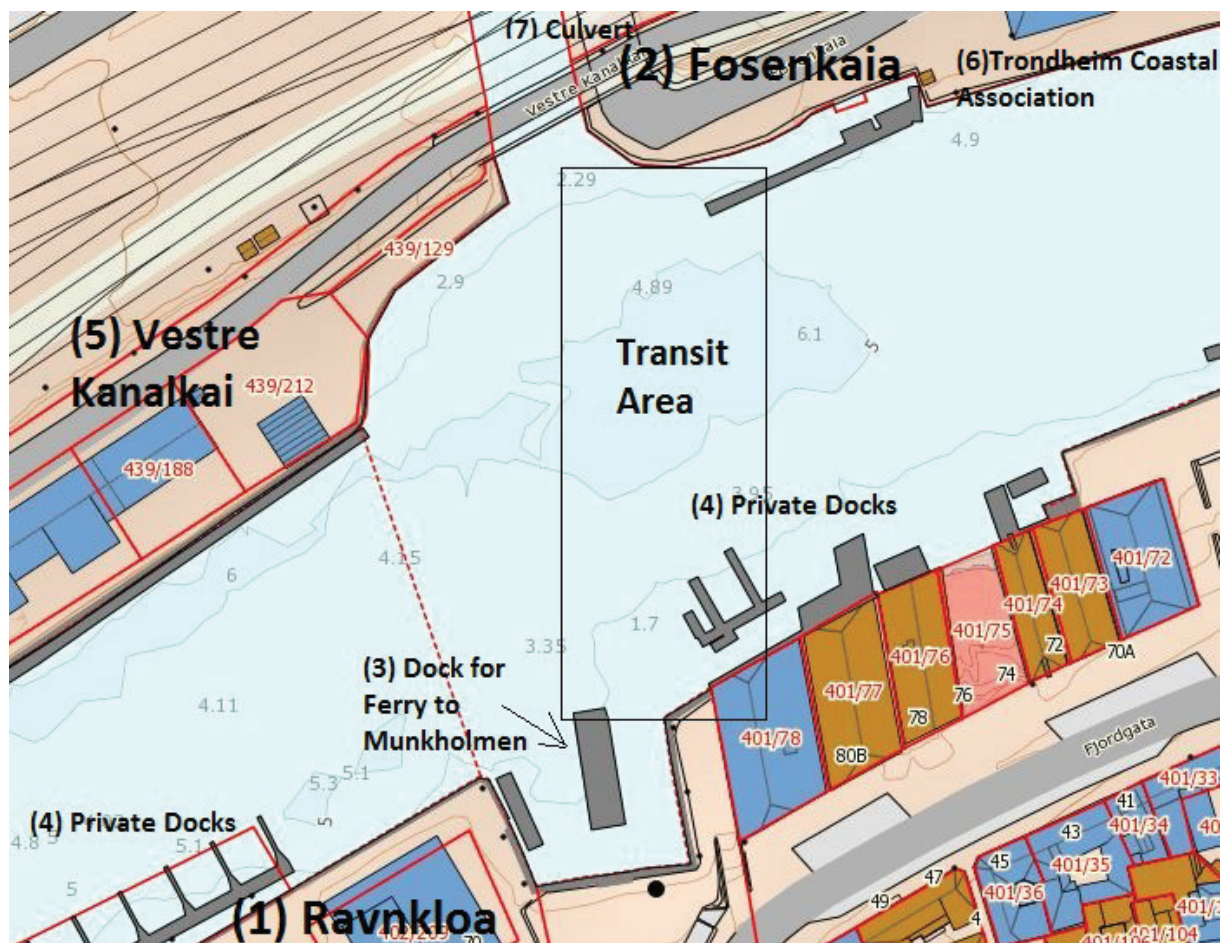

Figure 1: Illustration of the operational area (Norgeskart, 2016)

## 2.3 Relevant Rules and Regulations

Communication with the Norwegian Maritime Authority informed that the most relevant set of rules for this design study was the *Nordic Boat Standard*(NBS). These rules apply to commercial boats less than 15 metres long, including passenger vessels. The standard will set the structural requirements, anchor system design and other equipment- and design requirements found relevant. The standard use simplified requirements with regard to strength and stability, compared to the DNV GL standards for larger vessels. It is reasonable that additional requirements will be set by the Maritime Authority to secure the passengers safety when on board. As no personnel will be present to for instance hinder all passengers from standing on one side of the vessel, the stability of the vessel is crucial. The Maritime Authority further recommended using *The Regulation on Life-saving Appliances on Ships* when designing the evacuation plan and safety equipment on board. The evacuation plan was not considered in great detail in this study, but the regulation is noted as relevant for further work on the project. The safety equipment, such as life jackets and life buoys, will be designed using this regulation.

Further, the DNV GL standard *Hull Structural Design, Ships with Length Less than 100 metres* will be used to dimension the strength elements on the ferry structure. This was not required from the Norwegian Maritime Authority, but considered relevant as safety is a top priority for the design. Sintef Building and Infrastructure will be used to determine reasonable space requirements for different passengers groups, as well as to design the passenger lounge. The guidelines regarding wheelchair users will be particularly important as they have a limited reach and mobility. Their safety will depend on life jackets and other safety equipment being easily accessible for them. The lantern system will be designed using *Regulations for Preventing Collision at Sea*. The risk assessment will be performed using the IMO Guidelines for Formal Safety Assessment and ISO Standard 12100 *Safety of Machinery*. Finally, the arrangement drawings will be made using extracts from the Norwegian Standard for Technical Drawings.

While some existing regulations are compatible with autonomous vessels, others are not. To integrate autonomy into vessel design the regulation authorities have to cooperate to find a solution for evaluating the autonomous design, so that they can be certified. New regulations with specific requirements and criteria has to be set. Another option is

to compare the autonomous vessel to conventional vessels, and this way assure that the autonomous vessel is equally good or better. This could be done by comparison of the safety of an autonomous and conventional vessel to determine if the autonomous vessel is sufficiently safe. Lloyd's Register issued their first guide for cyber enabled ships in July 2016 (Lloyd's Register, 2016). In this guideline they suggest using a risk based approach to show that the risks in the design have been reduced to a tolerable level, if existing regulations are not appropriate to use.

A ship needs many different certificates to be able to operate. Certificates that cannot be obtained for an autonomous vessel could potentially be replaced by a new certificate specifically for autonomous vessels. This certificate could define if the autonomous vessel is sufficiently good to be put in operation.

## 3 Theoretical Background

The intention of this chapter is to provide the reader understanding of the basic concepts that form the basis for this design study. The design methods considered used for the project will first be presented, followed by the evaluation methods relevant for the design process. Finally, theoretical information that may be useful to better understand the methods and processes described in the thesis will be presented.

### 3.1 Design Methods

The purpose of design is to plan the achievement of specific goals using the minimum amount of resources within given boundaries. Endal et al. (2011) defines design as planning a future enterprise. Design is a complex process where both creativity and analytical skills are necessary for success. It depends on the intuition of the designer as well as other human qualities which there are little precise knowledge about. For this reason, developments of the field have moved towards methods on design rather than theory. This section will present design methods relevant for this study. (Endal et al., 2011)

#### 3.1.1 The Generic Design Method

The design process is characterized by its open ending. The goal is clear, but the final solution to achieve it is unknown. This makes room for the designers to use their personal creative powers. Necessary assumptions are made initially to enable the design process, and evaluated at a later stage to determine their success. The assumptions are rarely correct and usually need modifications to better fit the goal. It is an iterative process to improve these initial assumptions. The designer use insight gained from the first flawed assumption to improve the final solution in the next iteration. A solution that fulfills the initial goal and demands are gradually obtained through this process. The necessary number of iterations depends on the complexity of the task as well as the designer's ability to make good assumptions. (Endal et al., 2011)

Several definitions of the design process exists. A common structure is to divide the process into five phases. The work begins in the preparatory phase followed by the

divergent and the transforming phase. Here, the goal and limitations are set before possible solutions are suggested and transformed into concrete concepts. Further, the solutions are evaluated in the convergent phase. Several of them are removed. Finally, the best possible solution is presented for the customer in the communicating phase. The complete process is presented in figure 2. This same process is sometimes described using only three phases. The design is then obtained through the concept phase, the pre-project phase and the main-project phase. The concept phase includes the first three phases of the former division. The pre-project phase is intended to gather more detailed information of the concept chosen in the concept phase. Detailed information forms the basis for the final evaluation of the concept before it is finalized in the main-project phase. Here the specifications are set. (Erichsen, 1999)

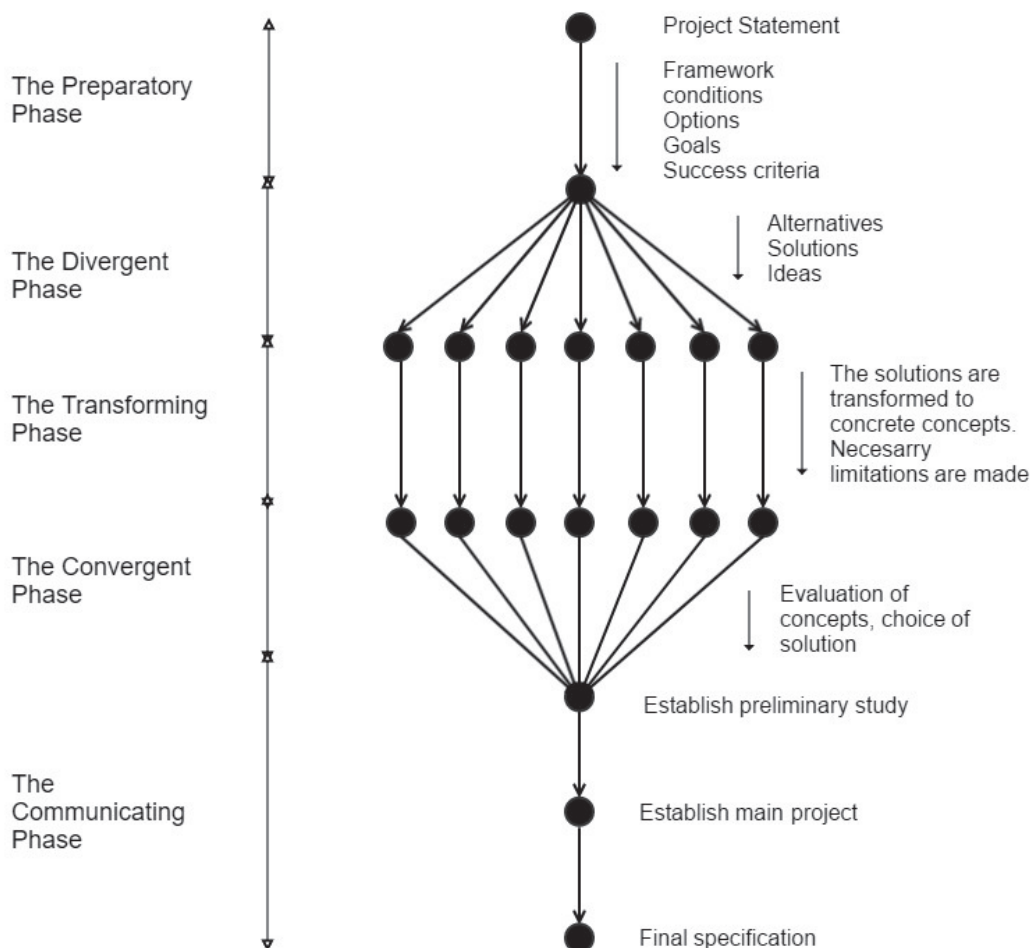

Figure 2: The five phases of the design, modelled after figure in Endal et al. (2011)

An alternative illustration of the design process is found in figure 3. The process follows the solid lines in the figure, starting in the centre. The first task consists of finding all relevant background information and set the framework conditions. A study of the market and framework conditions is necessary to find the limitations of the design. The objective is further determined and all goals for the project are set according to this. The next step is to develop ideas for different concepts. The concepts are developed to a satisfactory level of detail, before moving to the next step. Here the concepts are analyzed to determine their usefulness. The analyses may include calculations on resistance, stability and necessary propulsion power. Concepts that are not satisfactory are discarded. The next step is to evaluate the remaining concepts. The concepts may be evaluated on different criteria, like performance, economy, environmental performance and safety performance. Based on the evaluation, a decision has to be made on what concept to choose. The decision will be affected by what criteria is given the highest emphasis. If cost is more important than safety performance, the cheaper concept will be chosen over the safer one. The process results in the determination of the final design. If not satisfactory, a new iteration through the spiral is initiated to make improvements to the design. When compared to figure 2, it is apparent the the two illustrations describe the same approach. The centre of the design spiral equals the preparatory phase. The idea box in the spiral equals the divergent and transforming phase and the analyze box equals the convergent phase. Finally, the evaluation box equals the communicating phase as displayed in figure 2.

The design process is not as straight forward in practice as described in the figures. Framework conditions that are overlooked may result in large costs later in the project. New information is often discovered at a late stage in the process and it is therefore more likely to move back and forth between the phases. A concept might be taken to the analyze phase, where it is discovered that it is not feasible do to a new framework condition surfacing. The design process must then move back to the idea phase to reconsider the design. The dotted lines in the design spiral better illustrates how the progress normally proceeds. New information discovered late in the project may affect earlier decisions, making it necessary to go back and change for instance the framework conditions or certain design decisions.

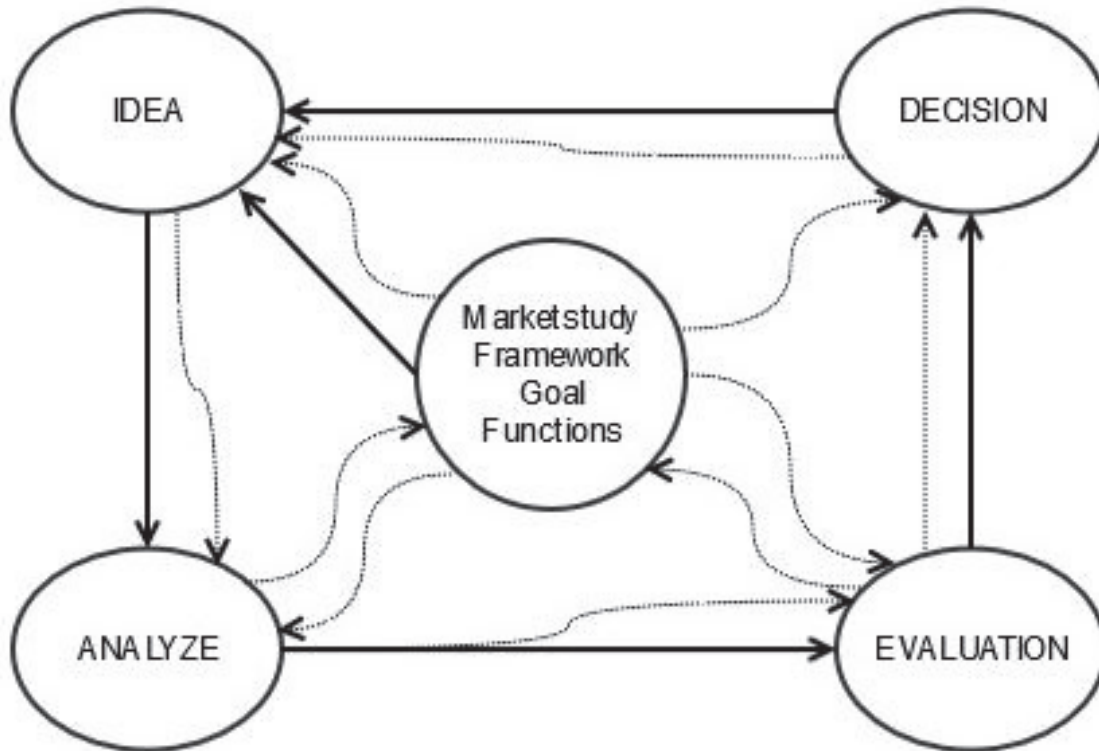

Figure 3: Design spiral describing the generic design process (Aanondsen, 2017)

### 3.1.2 The Traditional Marine Design Method

The traditional marine design process is based on the same principle as described in the previous section, only focused directly on naval projects. In marine design, the process is most commonly used for ship design. The process was initially based on people's experience with the ocean. Designers can today rely more on scientific foundations in their calculations. The marine design process is not directly applicable to other systems, despite the similarity to the generic process. In marine design, the entirety of the system is more prominent. A small change in one part of the design may have large impact on several other parts. (Endal et al., 2011)

The marine design process is often described by the design spiral. It describes the same principle as the subdivision of phases in figure 2. As ships are complex systems, it is impossible to determine all factors and variables simultaneously. The design spiral approach initiates by considering an existing vessel similar to the one being designed. The spiral then guides the designer through the iterative process of determining the necessary variables in an orderly manner, with the existing vessel as basis (Endal et al., 2011). It



functions as guidance when choosing the order in which the calculations are to be performed. The optimal order of calculations and decisions will reduce the total workload and increase the chances of a good result. Figure 4 shows a classical example of the marine design spiral, as first presented by Evans (1959).

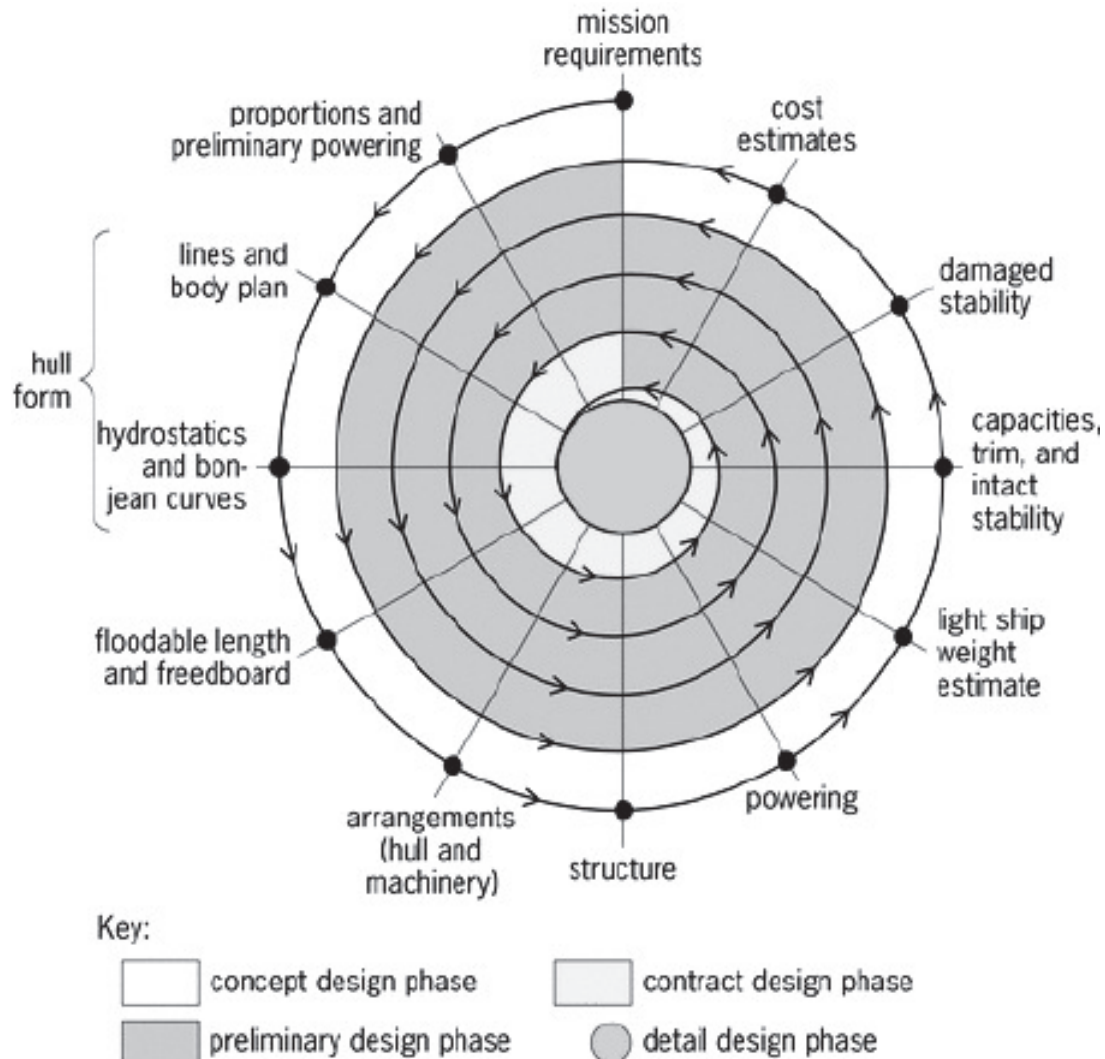

Figure 4: Design Spiral describing the marine design process (Evans, 1959)

### 3.1.3 The System Based Ship Design Method

System Based Ship Design (SBSD) was invented by Kai Levander. It was first presented in 1991 at the International Marine Design Conference (IMDC) in Japan (Levander, 1991). The approach reduces the number of loops needed to find a good solution, compared to the traditional marine design approach. This because it helps straighten the design spiral (Erikstad and Levander, 2012). Erikstad and Levander (2012) presents the design spiral

for the SBSD of offshore vessels in their report “System Based Design of Offshore Support Vessels”. The illustration is found in figure 5. The spiral looks approximately the same for all design cases and is included only to illustrate the methodology.

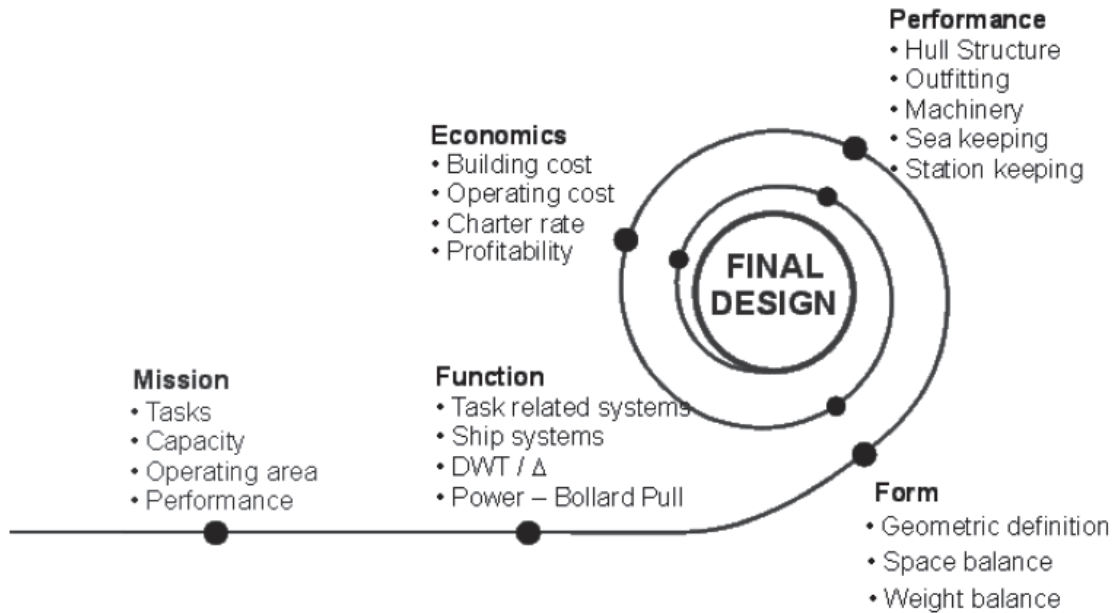

Figure 5: Design spiral describing the SBSD process (Erikstad and Levander, 2012)

The SBSD approach starts with the mission statement for the vessel. This statement is the basis for defining the relevant functions of the vessel. The main function of a product is determined from the mission statement for the product. Once the main function is set, possible solutions to fulfill this main function are considered. When the appropriate solution is chosen, relevant sub functions are determined. These are the necessary functions for the final solution to operate as desired, and are commonly known as the functional requirements for the solution. Jakobsen (1990) illustrates this functional analysis approach in his book "Produktutvikling". A rendering of his illustration is presented in figure 6 below.

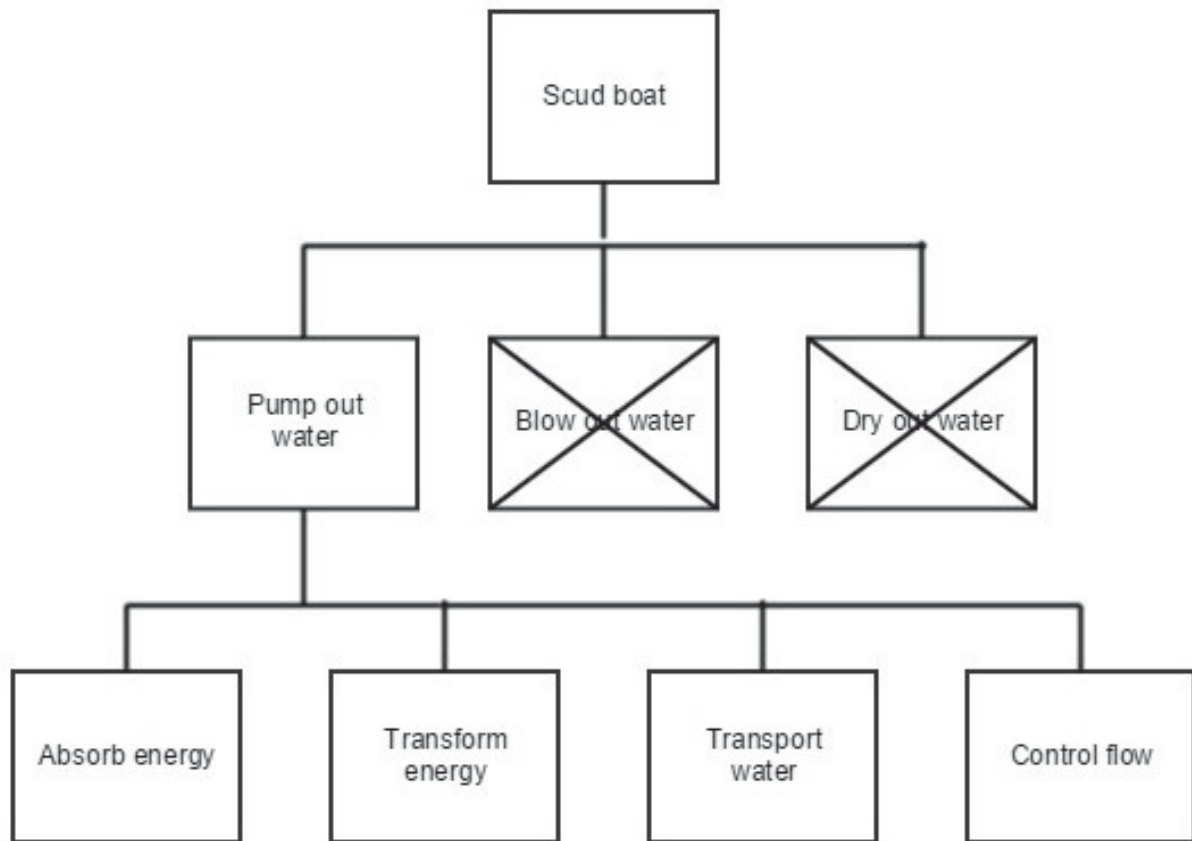

Figure 6: Example illustrating a functional analysis (Jakobsen, 1990)

Once set, the functional requirements are further transformed into relevant input data for the design process. The inputs are thus made up of demands and preferences for the vessels operation, based on the functional requirements. Further, they will determine the necessary capacity of the vessel. This is achieved by applying the inputs in a parametric exploration that will form the main dimensions while satisfying the capacity requirements. Once main dimensions are determined, the performance of the ship is set. This includes the speed, endurance and safety equipment. Finally, the building cost and the operation's economics are calculated (Levander, 2012). It is possible to perform this process for more than one design simultaneously. This way, different alternatives can be compared on a more detailed level than when using the traditional design spiral.

### 3.1.4 The Risk Based Ship Design Method

Risk Based Ship Design (RBSD) considers safety as an objective instead of treating it as a constraint. This is opposed to the norm in traditional ship design. This is done by introducing risk analysis into the traditional design process. The risk is used to measure how the design performs regarding the safety. By making safety a design objective, new technical solutions can be developed as the possible design solution space is larger. The new safety constraint in the design optimization can be seen in equation 1.

$$R_{Design} \leq R_{Acceptable} \quad (1)$$

$R_{Design}$  is the sum of all partial risk associated with the design, while  $R_{Acceptable}$  is the acceptable level of risk, set by whoever is approving the risk analysis in the RBSD. This can be the flag state or the classification society, who has to comply with international rules. The acceptable risk is specified either by comparing to a reference vessel that complies with existing rules, or by following risk acceptance criteria set by the International Maritime Organisation (IMO).

There are two main drivers behind RBSD. The first is making the realization of new transport solutions possible. Many new ideas challenge the existing regulations, which means that they cannot be approved. For instance, most regulations set requirements for crew on board, and an autonomous vessel would thus not be able to fulfill these requirements. By implementing RBSD, the relevant issues can be addressed and it can be proved that the new solution is at least as safe as required by regulations. The requirements are either set by comparing the solution with a reference vessel, or by some defined risk acceptance criteria. In this way RBSD allows for innovation and development of the ship industry. The second driver for the methodology is the possibility to optimize vessels that comply with rules by increasing their level of safety without increasing cost. It may also be possible to increase the earning potential while keeping the same level of safety.

To be able to use RBSD, it has to be aligned with the traditional design process where safety is included as an objective. To do this, tools for quantifying risk has to be developed. Regulatory framework must also be in place to aid the RBSD. The most important part

of the regulations is the risk evaluation criteria that has to be set in accordance with the IMO regulations.

### **The RBSD Methodical Approach**

RBSD is still under development, and it has no approved guidelines to follow. However, a general method has been suggested by Papanikolaou (2009). It is divided into five parts; definition of safety goals, identification of hazards, identification of critical design scenarios, definition of safety-related functional requirements and design decision-making.

The definition of safety goals considers safety as an objective in the design. Like other goals (service speed, capacity, services etc.), the safety goals are based on the ships mission and purpose. An example of a safety goal is no loss of human life due to ship accidents. This is considered a top level goal and to achieve it, a set of specific technical goals that supports the top goals have to be fulfilled. An example of a specific technical goal is sufficient residual structural strength in damage conditions. This could help avoid that the ship sinks, and thus reduce the chance of loss of human life if the ship gets damaged in an accident.

When the safety goals are set, the next step is to make sure that these goals are achieved. To do this, a set of functional requirements are determined based on the goals. The identification of these functional requirements are based on an assessment of circumstances that can prevent the achievement of the safety goals. To find these circumstances the question "What can go wrong?" has to be answered using hazard identification methods. There are several methods to choose from based on the case, purpose and design details, including HAZID, FMEA, SWIFT, HAZOP and PHA.

From the hazard identification, a set of generic design scenarios with calculable probabilities can be derived. Combining the scenarios, the life-cycle risk for the ship can be calculated. When the generic scenarios are found, design features and performance related to the specific vessel can be used to adapt the scenarios to the specific case. Methods typically used to find the critical scenarios are fault tree analysis (FTA), event tree analysis (ETA) and Bayesian Networks. When all hazards have been identified and the critical scenarios are found, specific functional requirements can be defined. These can be seen as safety performance requirements, and will be based on engineering judgment and safety knowledge. Along with the conventional performance requirements, these will be used

by the designer to create the baseline design. The combined process of identifying and analyzing hazards is known as a risk assessment. This analysis will be described in further detail in section 3.1.5.

The last step of the RBSD method is to use the safety related functional requirements as an extra set of decision parameters in the design decision making. The RBSD is here combined with the traditional design process. With parametric models for risk, performance and economics, it is possible to make good and cost-efficient design decisions and trade-offs between the different decisions parameters.

### **3.1.5 Risk Assessment for the RBSD Method**

A risk assessment is the overall process of performing a risk analysis and risk evaluation. A risk analysis is the use of available information to identify hazards, and estimate the risk associated with the individual hazards with regards to people, environment and property. It is proactive as it deals with potential accidents, and not previous accidents (Rausand, 2013). Risk evaluation is the process of judging whether or not a risk is tolerable. This will involve comparing the results of the risk analysis with some set risk acceptance criteria (Rausand, 2013).

The risk analysis has three main steps:

1. Hazard identification
2. Frequency analysis
3. Consequence analysis

Hazard identification includes finding all hazards and threats related to the system or process under consideration, along with the potential hazardous events. Frequency analysis involves estimating the frequency of the hazardous events found in step one. The estimates are usually based on an experts judgment or statistical data. Consequence analysis involves identifying all possible consequences of a hazard. This involves finding the sequence of events following the hazard as well as the end consequence. The risk assessment can be qualitative or quantitative. In a qualitative risk analysis, words and descriptive scales are used to describe the frequency and consequence associated with the potential hazards. A quantitative risk analysis uses numerical values for frequency and

consequence. A third possibility is to use a combination of qualitative and quantitative analysis, by representing the descriptive scales with numbers (Rausand, 2013).

The risk assessment is often used as input in a risk management process. The goal of this process is to identify and evaluate potential hazards in a system or process, and to find good risk control measures(RCMs). RCMs are means to eliminate or reduce potential risks. (Rausand, 2013)

One possible approach to risk assessment is the Formal Safety Assessment (FSA), developed by the IMO to support decision making when developing regulations. IMO's guideline for FSA was approved in 2002 (IMO VEGA, 2002). The guidelines describe the five steps of FSA in detail :

1. Identification of hazards
2. Risk analysis
3. Risk control options
4. Cost benefit analysis
5. Recommendation for decision-making

The purpose of the first step is to create a list off all possible hazards and associated scenarios for the case in question. The hazards in the list are ranked so they can be prioritized and hazards of minor importance can be discarded. The second step, risk analysis, investigates the hazards of higher importance. In this step, the causes and consequences of the hazards are investigated. The guidelines recommends doing this by performing a fault tree analysis (FTA) and an event tree analysis (ETA), and combining these two analyses into a risk contribution tree (RCT). The third step focus on the most crucial risks that need to be controlled, reduced or removed. It also looks at finding good risk control options (RCO). RCMs are found, evaluated, and combined to find the best options to manage the risk. The fourth step compares the benefit and cost of implementing the RCOs identified in step three. The main part of this step is to find the relevant costs and benefits of the RCOs. The last step uses all the information found in the four first steps, to make recommendations to the decision makers in question (IMO VEGA, 2002). The first four steps will be described in further detail in the remainder of this section.

## Identification of Hazards

There are many different methods developed for hazard identification. In this thesis, the preliminary hazard analysis (PHA) will be used and is therefore explained in detail here. The PHA was developed by the US Army. The method is used to identify hazards early in the design process, and gives an overview of where the biggest hazards in the system or process can be found. This is in accordance with step one of the FSA.

The PHA method is commonly divided into seven steps:

1. Plan and prepare
2. Identify hazards and hazardous events
3. Determine the frequency
4. Determine the consequence
5. Suggest risk-reducing measures
6. Assess the risk
7. Report the analysis

In the first step all the ground work of the analysis is done. This includes defining the format of the PHA work sheet, the acceptable level of risk, and the approach to measuring the risk. The system to be studied and its boundaries are also defined, along with the context of the analysis. The last part of this step is to gather all necessary information for the analysis. As PHA normally is used early in the design phase, the information available may be limited. The system may be broken down into subsystems or functions to easier identify hazards connected to the system (Flaus, 2013).

Step two comprises the main part of a PHA, making a list of potential hazards. Here the system defined in the previous step is used to identify hazardous elements and situations, and gathering them in a list. The hazards can be generated by a single element or situation, or following an unwanted interaction of different elements and situations. The information included in the hazards list may vary. To help identify hazards, a generic lists of hazards may be used as a guide.

Step three and four is used to determine the frequency and consequence of the different hazards that were found. These two steps can be done separately, but may be easier to



do in parallel. When the frequency and consequence is set, it is possible to calculate the Risk Priority Number (RPN). The RPN is the sum of the frequency and consequence of an accident. It is used to determine whether the hazard is acceptable or not.

In step five, risk reducing measures for the hazards should be considered and noted. This can include improvement of already existing measures or suggestions of new risk reducing measures. This step is not the most important goal of the PHA, but it can be helpful in further work with the PHA results.

Step six assesses the results of the PHA. To assess the risk, an evaluation has to be performed. A common approach is using the ALARP principle. ALARP is short for "as low as reasonably practicable". The ALARP principle was first introduced in the "Framework on Tolerability of Risk" for UK nuclear stations (Rausand, 2013). The ALARP principle divides the risk into three levels; the unacceptable level, the ALARP level and the broadly acceptable level. In the unacceptable level, all risks are intolerable and risk reducing measures are required. In the ALARP level, risk reducing measures are wanted. They may not necessarily be implemented if the benefit of the measure is not big enough. The benefit is often compared to the cost of implementing it. In the last level, the risks are tolerable and no risk reducing measures are required. Implementing risk reducing measures for these risks is often not economical, and the money should rather be spent reducing risks that are more pressing (Rausand, 2013).

The ALARP principle can be combined with a risk matrix to give a good visual representation of which level the different risks are in. The RPN that is calculated from the frequency and consequence of each hazard, can be entered into a risk matrix. This gives a good visual illustration of the risk by adding color coding and numbers to the matrix. This will indicate which events have the highest risk. Figure 7 shows a risk matrix with color coding for the different ALARP levels.

| Frequency/<br>Consequence | 1<br>Improbable | 2<br>Remote | 3<br>Possible | 4<br>Occasional | 5<br>Fairly normal |
|---------------------------|-----------------|-------------|---------------|-----------------|--------------------|
| 5<br>Catastrophic         | Yellow          | Yellow      | Red           | Red             | Red                |
| 4<br>Severe loss          | Green           | Yellow      | Yellow        | Red             | Red                |
| 3<br>Major Damage         | Green           | Green       | Yellow        | Yellow          | Red                |
| 2<br>Damage               | Green           | Green       | Green         | Yellow          | Yellow             |
| 1<br>Minor damage         | Green           | Green       | Green         | Green           | Yellow             |



|   |  |
|---|--|
|  | Acceptable region - no further risk reduction needed                 |
|  | ALARP region - use the ALARP principle and consider further analysis |
|  | Not acceptable region - risk reduction required                      |

Figure 7: Risk matrix illustrating the risk levels (Rausand, 2013)

The last step concerns gathering results, and conclusions from the PHA, and reporting it in a clear and orderly manner. This is usually done in a PHA worksheet. Table 1 shows an example of what can be represented in a PHA worksheet.

Table 1: PHA worksheet

| System element | Hazard | Hazardous event | Cause | Cons. | Freq. | Risk Cons. | RPN | Risk Reducing Measures |
|----------------|--------|-----------------|-------|-------|-------|------------|-----|------------------------|
|                |        |                 |       |       |       |            |     |                        |

### Risk analysis

The most critical hazards from the PHA can be further investigated by using FTA and ETA. A fault tree is a top-down logic diagram that shows the relationship between a critical event and causes for this event. The fault tree starts with the top event, and moves down in levels. The causes located on the lowest level are the basic events. FTA is one of the most commonly used methods for risk studies. It is commonly used for mechanical- and electromechanical systems, but can also be used for other systems (Rausand, 2013).

The FTA uses logical gates to connect the event and the causes. FTA assumes binary operational modes, which means that all events from the top event and down will either

occur or not occur. It is also a deterministic model, meaning that when the fault tree is constructed and the states of the basic events are known, the state of the top event and the intermediate events are also known. For every potential top event in a system, a new fault tree has to be constructed (Rausand, 2013). The top events are in this study the most critical hazards from the PHA.

An ETA is a method used for modelling and analysing accident scenarios. It describes the relation between an initiating event and the possible consequences. Development of potential accident scenarios is important in a risk analysis, and ETA is the most common method used for this purpose (Rausand, 2013).

The ETA uses a logical diagram that shows the relationship between an initiating event and the events that describe the possible outcomes. The ETA is, like the FTA, a binary method. The events in the ETA will either occur or not occur, and two different events can not happen at the same time. The initiating event can develop into several consequences, and the likelihood of one event is dependent on the previous one (Rausand, 2013). The initiating event in an ETA is equivalent to the top event in a FSA.

A RCT is a tool that combines the fault tree and the event tree, giving a more complete overview of an accident scenario. As the FTA is used to study the causes of a hazardous event, and the ETA is used to study the possible consequences following the same event, the two methods fit into the bow-tie model. A representation of a bow tie model is shown in figure 8. As can be seen in the figure, the barriers can be both proactive and reactive. The proactive barriers are found on the left side of the figure, and the reactive on the right side. The proactive barriers act to avoid the hazardous event of occurring in the first place, while the reactive barriers are there to mitigate or avoid certain consequences when the hazardous event has occurred.

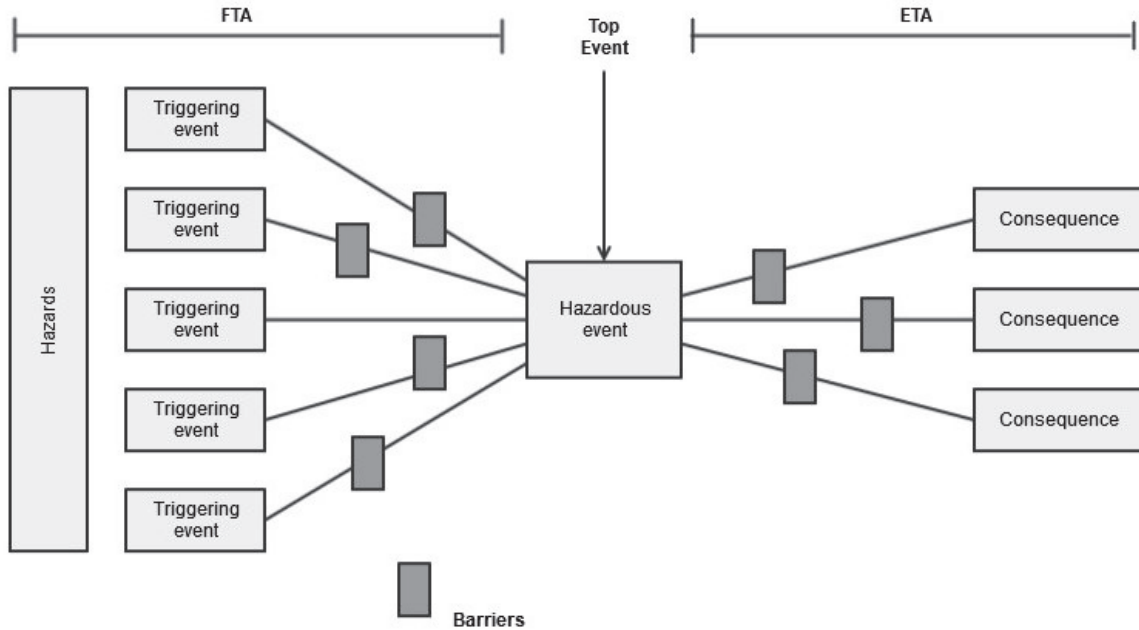

Figure 8: The bow-tie model, modelled after figure in Rausand (2013).

### Risk Control Options

When the critical hazards have been identified and further analyzed, RCMs can be suggested. There are two main types of risk reducing measures; preventive measures and mitigating measures (Rausand, 2013). The preventive measures are intended to reduce the frequency of the hazardous events, while the mitigating measures are intended to reduce or avoid the consequences following the hazardous event. If possible, the preventive measures should be prioritized as they prevent the hazard of occurring in the first place (Rausand, 2013).

In 1973 William Haddon suggested a list of ten strategies for risk reduction. The points on this list can be merged into four categories. The first category involves eliminating, substituting and/or mitigating the risk. This strategy will lead to an inherently safer design and can be achieved by for example removing, replacing or minimizing the amount of a dangerous substance. The second category involves prevention of risk. The frequency or consequence is reduced by changing the design or adding proactive barriers. The third category comprise of detecting and warning against hazards. This is done by having control systems and operators who detect the hazard and send a warning, to ensure control or mitigation of the consequences. The last category consists of mitigating the consequences. This can be done by having reactive barriers, separating the energy released

by the hazard and the assets that can get damaged, make the assets more robust or by improving system for rehabilitation and first aid (Jensen, 2007)(Rausand, 2013).

Which risk controlling measures are implemented has to be decided by comparing the benefits of the reduction, and the cost of implementing the measures. The RCMs can be put together in different RCOs (Rausand, 2013).

### Cost Benefit Analysis

Cost benefit analysis (CBA) is a tool to help choose what RCMs and RCOs that are beneficial to implement for the design. According to the UK *Health and Safety Executive*, a RCM should be implemented if the cost to benefit ratio is smaller or equal to a disproportionalityDF, as shown in equation 2 (Asbjørnslett, 2015).

$$\frac{\text{Cost of measure}}{\text{Benefit of measure}} \leq \text{DF} \quad (2)$$

The cost benefit analysis deals with present values, as it looks at the cost and benefits over the lifetime of the system. This disproportionality factor has to be defined by the analyst. The value of this factor depends on the severity of the risk considered. A higher DF implies that it is acceptable with a higher cost to achieve the benefit. Therefore it is reasonable to use higher values of DF for higher risks, as it is more pressing to reduce these (Rausand, 2013).

The cost of the risk reducing measure is an estimate of the total cost of implementing this measure. This can be the cost of a purchase, an installation or training of crew. It can also be a cost related to the operation, like extra fuel or lost productivity. The benefit of the risk reducing measure is an estimate of the achieved cost reduction by fewer injuries or fatalities, less damage to assets and other benefits (Rausand, 2013).

One of the challenges with cost benefit analysis is that both the costs and the benefits have to be expressed in monetary terms. There are issues with putting monetary value on the benefits, especially when it comes to a human life. Another challenge is that the risk can not always be eliminated. It might not be possible to further reduce the risk, and the risk has to be accepted (Rausand, 2013).

## 3.2 Methods for Evaluation of Design and Ideas

This section presents methods used in this study to evaluate concepts or ideas. The intention is to provide the reader with a better understanding of the methodology that form the basis for several design decisions.

### 3.2.1 Methods for Ranking of Alternatives

When designing, it is common that many different solutions are generated. To help evaluate, and choose between different solutions, the solutions can be assessed and compared by using a ranking method. One such ranking method is the weighted objectives method. It looks at different objectives, and assigns numerical weights to them based on how important they are for the design solution. The alternative solutions are then given numerical scores that reflect how they perform within the various objectives. The objectives are often referred to as criteria (Cross, 1989).

The first step of the method is to find the objectives relevant to the design. Without any objectives, there are no grounds to evaluate the design. The objectives can include technical, economical, safety and user related factors. When the objectives have been set, they can be assigned weight. Objectives with higher priority should be weighted higher than ones with lower priority. The weights should add up to 100%, thus there are 100 points to distribute out on the objectives (Cross, 1989).

Further, the design solutions are evaluated against the objectives. A scale has to be set to describe the design performance. This can be a qualitative scale that has been given numerical values. Each design solution is then given scores for its performance on each objective. The final steps of the method is to calculate the final score for each design solution. This is done by multiplying the weights of the objectives with the performance score for the design, and adding together for all objectives. The best solution is then the one with the highest total score (Cross, 1989).

When using ranking methods like this there are a couple of pitfalls to look out for. Setting the weights and scores are based on personal opinions and common sense, and may vary from person to person. It is also possible to end in the trap of giving out scores to end on a certain solution that was predetermined. Working in a team can help with deciding

scores and weights, as different people can provide input when setting the scales. Tools like an objective tree can also be helpful to set the weights of the objectives (Cross, 1989).

### 3.2.2 Life Cycle Cost

Life cycle cost(LCC) is a method to determine cost-effective alternatives in a project. The alternatives needs to fulfill the requirements for the final product, and the alternative with the lowest LCC is the most cost effective solution. LCC is the sum of all significant, time-adjusted costs relevant to a given course of action over a study period. (Ruegg and Marshall, 1990)

There are several applications of LCC:

- The accept/reject application
- The design/size application
- The locate cost-driven businesses application
- The replacement application
- The lease/buy application
- The combine interdependent systems application
- The allocating of a limited budget within a given building or facility application

Accept/reject analyze whether or not to include a system or modification into a product. If the system or modification lowers the LCC for the product, it is reasonable to include it. The design/size application compares different designs alternatives to determine which results in the lowest LCC. An example of this is whether to use a durable aluminium alloy or weaker type. The durable aluminium is more expensive, but requires less maintenance through the lifetime of the vessel. To locate cost-driven businesses is about finding the best operational area with respect to cost. For example deciding where to locate a factory. Whether to produce in China or in Norway will typically be determined by production costs. The replacement application is about finding the optimal replacement period according to cost. This can be relevant when deciding whether to replace components when failing, or perform regular maintenance. The lease/buy application is used to decide whether it is more cost effective to lease a product over a period of

time or buy it. Combining interdependent systems looks at how system affects each other to find the best combination. The best combination is the alternative resulting in the lowest LCC. For example, the thickness of the insulation in a wall will affect the required efficiency of the heating ventilation and air conditioning system (HVAC). To allocate a limited budget within a given building or facility is about choosing the combination of products, both interdependent and independent, that is within the budget and has the lowest LCC. (Ruegg and Marshall, 1990)

LCC analyses are normally presented in present value or annual value. Present value represent the cost for the whole project in current time value. Annual value is a uniformly recurring annual cost over the project lifetime. It is important to be aware of the construction period of the project. Several projects may have different lengths of construction period, which will affect the costs. The cost of a construction period can be expressed by being phased in over the period or by being a lump-sum future cost.

### **3.3 Additional Relevant Theory**

This sections presents theory considered relevant for the reader that is not a design method or evaluation technique. First, the concept of autonomy will be defined. Further, the theory forming the basis for stability- and resistance calculations are presented, followed by definitions of different drawings made in the study. The stability- and resistance theory was considered relevant as the calculations in the study will be performed using computer programs. A basic understanding of the underlying theory is important to be able to evaluate the results.

#### **3.3.1 Definition and Levels of Autonomy**

Designing an autonomous vehicle introduces new parameters and constrains into the design process. The design has to be able to work and respond correctly in cooperation with the autonomous system, it has to be sufficiently safe and it has to be approved by regulatory instances. To fully understand the impact on the design, an understanding of autonomy is required.

The word autonomy comes from the greek word *autonomos*, which is a combination



of autos, meaning “self”, and nomos, meaning “law”. Combined, they are understood to mean “having its own laws”. The word autonomy is used to explain independence for countries and people, and has also been adopted to explain technology that makes decisions and performs tasks without human interaction (Oxford Living Dictionaries, 2017).

It is not easy to define what an autonomous vehicle is, and different definitions exist. The United States Department of Transportation defines an automated vehicle as follows;

“Automated vehicles are those in which at least some aspect of a safety-critical control function (e.g., steering, throttle, or braking) occurs without direct driver input. Automated vehicles may be autonomous (i.e., use only vehicle sensors) or may be connected (i.e., use communications systems such as connected vehicle technology, in which cars and roadside infrastructure communicate wirelessly).(United States Department Of Transport, 2017)”

Lloyd’s Registre use a similar definition of an autonomous vehicle;

“Autonomous vehicles are vehicles which can drive themselves without human supervision or input. Unmanned vehicles are vehicles which are either controlled remotely, or perhaps operate autonomously. Vehicles can also operate semiautonomously: taking some control of aspects of their driving, whilst a human driver retains control of others.(Yeomans, 2014)”

The definitions use words like "connected", "semiautonomous" and "controlled remotely", which points to there being different degrees of autonomy. This variation in definition makes it necessary to define levels of autonomy to help separate the different types of autonomous vehicles. NHTSA has created a hierarchy of five levels to clarify the autonomy levels for automated vehicles. The autonomy levels, by their definition, are given in table 2.

Table 2: NHTSA’s hierarchy of automation levels (Anderson et al., 2014)

| No. | Level                           | Description  |
|-----|---------------------------------|--|
| 0   | No automation                   | The driver is in complete and sole control of the primary vehicle functions (brake, steering, throttle, and motive power) at all times, and is solely responsible for monitoring the roadway and for safe vehicle operation.   |
| 1   | Function-specific automation    | Automation at this level involves one or more specific control functions; if multiple functions are automated, they operate independently of each other. The driver has overall control, and is solely responsible for safe operation, but can choose to cede limited authority over a primary control; the vehicle can automatically assume limited authority over a primary control (as in electronic stability control); or the automated system can provide added control to aid the driver in certain normal driving or crash-imminent situations (e.g., dynamic brake support in emergencies). |
| 2   | Combined-function automation    | This level involves automation of at least two primary control functions designed to work in unison to relieve the driver of controlling those functions. Vehicles at this level of automation can utilize shared authority when the driver cedes active primary control in certain limited driving situations. The driver is still responsible for monitoring the roadway and safe operation, and is expected to be available for control at all times and on short notice. The system can relinquish control with no advance warning and the driver must be ready to control the vehicle safely.   |
| 3   | Limited self-driving automation | Vehicles at this level of automation enable the driver to cede full control of all safety-critical functions under certain traffic or environmental conditions, and in those conditions to rely heavily on the vehicle to monitor for changes in those conditions requiring transition back to driver control. The driver is expected to be available for occasional control, but with sufficiently comfortable transition time.   |
| 4   | Full self-driving automation    | The vehicle is designed to perform all safety-critical driving functions and monitor roadway conditions for an entire trip. Such a design anticipates that the driver will provide destination or navigation input, but is not expected to be available for control at any time during the trip. This includes both occupied and unoccupied vehicles. By design, safe operation rests solely on the automated vehicle system.  |

The levels vary from no autonomy, where the driver has full control, to fully automated vehicle, where there is no driver or crew to control any functions. NHTSA’s levels are pri-

marily intended for cars. Lloyd's Register have developed a similar hierarchy, specifically for ships. This has seven levels, and can be seen in table 3.

Table 3: Lloyd's Registers's hierarchy of automation levels for ships (Lloyd's Register, 2016)

| No. | Level                                   | Description  |
|-----|---|--|
| 0   | Manual - no autonomous function         | All action and decision making is performed manually.  |
| 1   | On-ship decision support                | All actions at the ship level are taken by a human operator, but a decision support tool can present options or otherwise influence the actions chosen (For example route planning).   |
| 2   | On and off-ship decision support        | All actions at the ship level are taken by human operator on board the vessel, but decision support tools can present options or otherwise influence the actions chosen. Data may be provided by systems on or off the ship.   |
| 3   | 'Active' human in the loop              | Decisions and actions at the ship level are performed autonomously with human supervision. High impact decisions are implemented in a way to give human operators the opportunity to intercede and over-ride them. Data may be provided by systems on or off the ship. |
| 4   | Human on the loop - operator/supervisor | Decisions and actions are performed autonomously with human supervision. High impact decisions are implemented in a way to give human operators the opportunity to intercede and over-ride them.   |
| 5   | Fully autonomous                        | Unsupervised or rarely supervised operation where decisions are made and actioned by the system, i.e impact is at the total ship level.  |
| 6   | Fully autonomous                        | Unsupervised operation where decisions are made and actioned by the system, i.e impact is at the total ship level.   |

Ships are more complex than road vehicles and the hierarchy from Lloyd's Register is therefore somewhat more detailed. While a road vehicle can be manned by one individual, a ship often needs an entire crew. The ship also has more systems that have to run for it to function, and therefore many opportunities for automating only certain systems exists. While the NHTSA's hierarchy focus on the cars' ability to maneuver traffic by itself, Lloyd's Register's focus more on the ship being able to perform entire operations on its own.

Lloyd's Register's hierarchy defines more closely whether an operation is aided by an actively present human, supervised by an operator, rarely supervised or completely unsupervised. Most road vehicles are meant for transportation of passengers, and will therefore

always have people on board. This means that there will always be someone to supervise or observe. The levels from NHTSA therefore focus on whether or not the passengers can control the car, and less on the supervision. Automated ships could mean there are no humans on board at all, and therefore the focus is on whether there is supervision or not.

### 3.3.2 Vessel Resistance

To able a ship to move forward energy has to be supplied. The amount of energy depends on the resistance the vessel meets in the water and air, as well as how much of the energy supplied is transformed to effective motion energy for the vessel . Resistance will grow exponentially with the speed of the vessel. Many methods have developed for calculating the resistance, both empirical and numerical methods, however the most common way to decide the resistance of a ship is by performing model experiments. In this study the focus is on the methods for calculating resistance in the program ShipX, developed by Marintek (now Sintef Ocean).(Endal et al., 2011)

To calculate the resistance of a ship is a complex task, as the resistance is a result of many different resistance components. The two main resistance components are the friction resistance and the residual resistance. The total resistance is then the sum of these two components. The residual resistance can be split into a group of smaller resistance components, the most important one is the wave resistance. (Endal et al., 2011)

ShipX use a plugin called Waveres to calculate the wave resistance. Waveres uses potential theory, with linear solutions to the problem, and adds nonlinear corrections for an even better result. Viscous effects are neglected and the problem is solved as a steady state problem. Effects of trim, sinkage and transom stern are not included. The linear problem solved is the Neumann-Kelvin problem, that use the classic free surface condition satisfied on the mean water surface. At forward speed zero, the mean water surface is defined by the water plane area (Steen, 2000).

Waveres assumes that nonlinear effects are only located in the bow region. In this area, a linear, second order and nonlinear  $2\frac{1}{2}$ D methods are used to predict nonlinear contributions to the bow region.  $2\frac{1}{2}$ D methods use the two dimensional Laplace equation, and a three dimensional free-surface condition, thus the name  $2\frac{1}{2}$ D method . It is only valid for high Froude numbers, and the method is therefore applied from the bow to the

section where the local Froude number is larger than  $F_{n,loc}^{min}$ . Still, not for sections after the midship. In ShipX,  $F_{n,loc}^{min}$  is set to 0.6. The total nonlinear contribution to the wave resistance is then calculated as shown in equation 3. (Steen, 2000)

$$R_W^{non} = R_{non}^{2^{1/2}D} - R_{lin}^{2^{1/2}D} \quad (3)$$

The output from waveres includes a wave resistance coefficient ( $C_W$ ) a modified viscous resistance coefficient ( $C_V$ ) and the correction factor  $F_{ds}$ .  $F_{ds}$  accounts for the fact that the wetted surface at speed is larger than the nominal wetted surface. Based on these coefficients, the residual resistance coefficient ( $C_R$ ) is calculated in ShipX, as shown in equation 4. (Steen, 2017)

$$C_R = C_W + C_V^{Waveres} - C_F^{ITTC}(1+k) = C_W + C_F^{ITTC}(1+k)F_{ds} \quad (4)$$

$C_F^{ITTC}$  is the standard ITTC'57 formula for frictional resistance coefficient, and k is the form factor. ShipX calculates the residual resistance for two different form factors, one from user input and one calculated by the program. The two different residual resistances are referred to as  $C_{RU}$  and  $C_{RC}$ . The default form factor for the user input is calculated by the MARINTEK standard formula showed in equation 5. In MARINTEK's formula,  $T_{AP}$  and  $T_{FP}$  are the draughts at the aft- and forward perpendicular, respectively.  $C_B$  is the block coefficient,  $L_{WL}$  is the waterline length, B is the moulded breadth and  $\phi$  is the fullness parameter. (Steen, 2000)

$$k = 0.6\phi + 145\phi^3 \cdot 5 \quad \text{Where} \quad \phi = \frac{C_B}{L_{WL}} \sqrt{(T_{AP} + T_{FP})B} \quad (5)$$

The form factor calculated by the program is calculated as Holtrop's form factor for  $C_B < 0.6$ , MARINTEK's form factor for  $C_B > 0.7$  and for  $0.6 < C_B < 0.7$  it interpolates between the two. Holtrop's formfactor can be seen in equation 6. In the Holtrop formula, L is the waterline length, T is the average draught and  $C_P$  is the prismatic coefficient. LCB is the longitudinal position of the centre of buoyancy forward of 0.5 L, given as a percentage of L. B is the moulded breadth and  $\nabla$  is the moulded displacement volume. (Steen, 2000)

$$k_1 = -0.07 + 0.487118 \cdot C_{14} \cdot \left(\frac{B}{L}\right)^{1.06806} \cdot \left(\frac{T}{L}\right)^{0.46106} \cdot \left(\frac{L}{L_R}\right)^{0.121563} \cdot \left(\frac{L^3}{\nabla}\right)^{0.36486} \cdot (1 - C_P)^{-0.604247} \quad (6)$$

$$\text{Where } C_{14} = 1 + 0.011 \cdot C_{stern} \quad \text{and} \quad L_R = L \cdot \left(\frac{1 - C_P + 0.06 C_P \cdot LCB}{4 C_P - 1}\right)$$

Now the total resistance coefficient  $C_T$  can be calculated as shown in equation 7.  $C_R$  is the residual resistance coefficient,  $C_{FS}$  is the friction resistance coefficient,  $\Delta C_F$  is the hull roughness coefficient,  $C_{AAS}$  is the air resistance coefficient and  $C_{BDS}$  is the resistance coefficient for transom stern.

$$C_T = C_R + (1 + k) \cdot (C_F + \Delta C_F) + C_{AAS} + C_{BDS} \quad (7)$$

Using  $C_T$ , the total ship resistance can be calculated as shown in equation 8. The effective towing power,  $P_E$ , can be calculated as shown by equation 9. By dividing the effective towing power with the hull efficiency and the propeller efficiency, necessary energy delivered to the propeller can be set as shown by equation 10 (MAN Diesel & Turbo, 2017).

$$R_T = \frac{1}{2} \rho \cdot V^2 \cdot S \cdot C_T \quad (8)$$

$$P_E = R_T \cdot V \quad (9)$$

$$P_D = \frac{P_E}{\eta_H \cdot \eta_B} \quad (10)$$

To calculate the necessary power output from the batteries, an energy efficiency has to be set. The propulsion chain will always have losses. In conventional propulsion chains, where the ship is equipped with a mechanical prime mover and propeller, the total efficiency is the sum of the hull efficiency, the propeller efficiency and the shaft efficiency. With batteries as the prime mover, the shaft efficiency is no longer relevant.

For batteries, the energy efficiency ( $\eta_E$ ) is more applicable. It is the total energy out of the battery divided by the total energy into the battery. This can also be expressed as the columbine effect multiplied with the voltage effect. The energy efficiency for batteries is considered to be much higher than for fuel engines. Li-ion batteries have high columbine efficiency, starting at almost 100% in the early stages of its lifespan. The net columbine efficiency is commonly set to 90 %. The voltage efficiency can be set to 87%. This gives a energy efficiency of 78%. Compared to the diesel and gas engines that have efficiency in the range 40 – 50 %, the batteries represents an improvement in the efficiency of the propulsion chain (Wartsila, 2014). The required battery output power is then calculated as shown in equation 11. (University of Colorado, 2017)

$$P_B = \frac{P_D}{\eta_E} = \frac{P_E}{\eta_H \cdot \eta_B \cdot \eta_E} = \frac{P_E}{\eta_T} \quad (11)$$

### 3.3.3 Vessel Stability

That a ship should be able to float stable with the right side up is one of the most basic requirements for a ship. To fulfill the requirement of being stable, the vessel has to be stable enough to withstand heeling and loads from different weather and sea states. Stability is also important if the ship is damaged, for example if the vessel collides or run aground. The vessel should therefore have sufficient damage stability. To verify that the stability of the vessel is sufficient, calculations should be made.

Transverse initial stability determines if the vessel has the ability to right itself back to the equilibrium position, after being affected by an external force that causes the vessel to heel. It will also reveal if the vessel will heel by itself and possibly capsize. The results of the initial stability calculations holds for heeling angles ( $\phi$ ) up to  $\pm 10^\circ$ , and is exact for heeling angle  $\phi = 0^\circ$ .

The requirement for initial stability states that the metacentric height, GM, has to be larger than zero. When the GM is smaller than zero the vessel has negative initial stability. If this is the case, the ship will heel by itself. Equation 12 shows how the GM is calculated. BM is the initial metacentric radius, KB is the vertical placement of the center of buoyancy and KG is the placement of the vessels center of mass.

$$GM = KB + BM - KG \quad (12)$$

Fulfilling the GM requirement is not enough to secure sufficient stability. The vessel also has to be able to withstand larger heeling angles. An important value to consider when analyzing larger heeling angles is the righting arm ( $GZ(\phi)$ ).  $GZ(\phi)$  is the shortest distance between the buoyancy's line of attack and the centre of mass G. The buoyancy's line of attack is the line showing the direction of the buoyancy force. The size of  $GZ(\phi)$  will decide the size of the righting moment (MR). At larger heeling angles, the metacentre has a new position for every angle  $\phi$ . This new metacentre is often referred to as the false metacentre,  $M_{\phi F}$ . The new metacentre result in a residual stability (MS( $\phi$ )) added to the  $GZ(\phi)$ .

The stability at larger heeling angles is considered using of GZ - curves. This is a plot of GZ as a function of heeling angle  $\phi$ . In addition to checking the stability at larger heeling angles, the GZ curve can be used to study how dynamic forces, like wind and waves, affect a vessel. Figure 9 shows a typical GZ curve. At a large heeling angle  $\phi$  the GZ will go from positive to negative. This is the angle where the curve crosses the x-axis in the figure. This angle is called the angle of vanishing stability, because the vessel loses its stability. The vessel will here capsize, as it no longer has any MR.

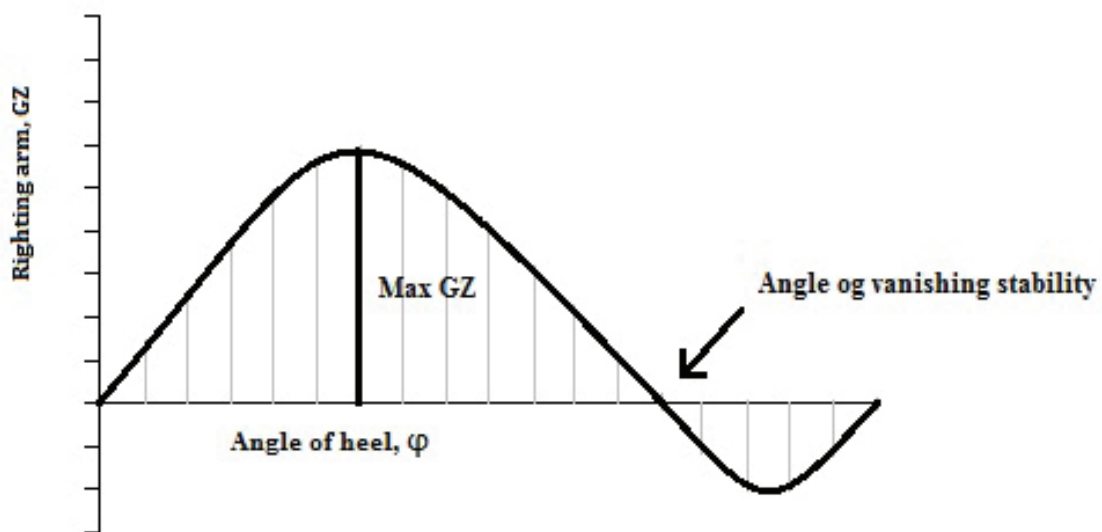

Figure 9: Generic example of a GZ curve



The freeboard of a vessel will affect the GZ curve. With larger freeboards,  $MS(\phi)$  will have its maximum value at a higher heeling angle. This because the vessel must heel more before the waterline meets the edge of the deck. A larger  $MS(\phi)$  will improve the  $GZ(\phi)$  at larger heeling angles. The GM value of a vessel will also affect the GZ curve. A larger GM equals larger  $GZ(\phi)$ . Equation 13 shows how to calculate the  $GZ(\phi)$  value. When the GM value increases, the first term in the equation will increase and thus improve the stability. The weight distribution on a vessel is therefore important, as it is advantageous for the center of mass to be as low as possible.

$$GZ(\phi) = GM \cdot \sin(\phi) + MS(\phi) \quad (13)$$

The GZ curve can also be used to find the maximum heeling angle at a given heeling moment, MK. By assuming equilibrium between the righting moment and the heeling moment, equation 14 can be used to find a term for the arm of the heeling moment. By plotting this into the GZ curve, the static heeling angle ( $\phi_S$ ) can be found as the intersection of the GZ curve and the curve for the arm of the heeling moment. A GZ curve where the arm of the heeling moment is plotted can be seen in figure 10. Being able to find the angle caused by different heeling moments makes it possible to study how a vessel reacts to different heeling moments, caused by wind, waves, displacement of weight or other external forces.

$$\begin{aligned} MK(\phi) = MR(\phi) &= GZ(\phi) \cdot \nabla \cdot \rho \\ \implies GZ(\phi) &= \frac{MK(\phi)}{\nabla \rho} = \frac{MK(\phi)}{\Delta} \end{aligned} \quad (14)$$

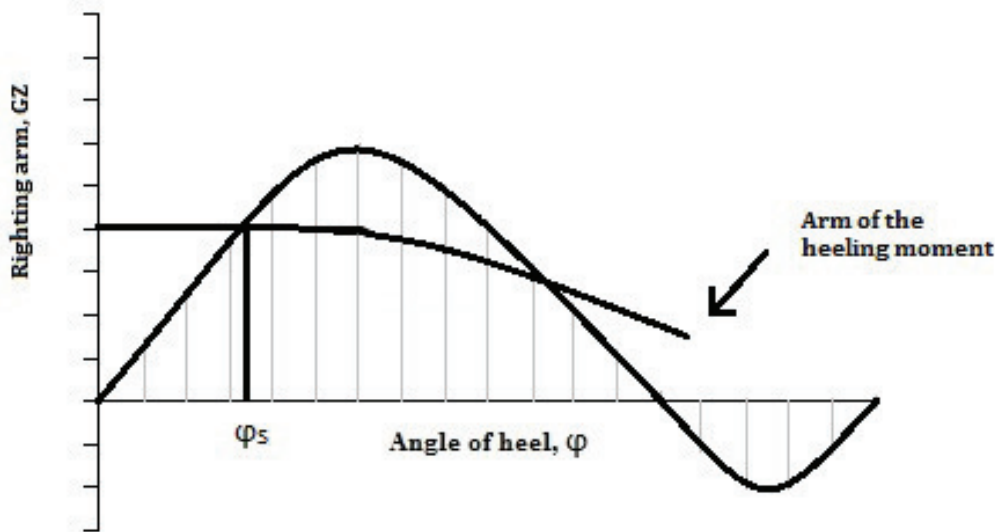

Figure 10: Example of GZ curve including arm of heeling moment

Finally, a vessel is also affected by moments in the longitudinal direction, causing it to trim. Trim is the equivalent of heeling, only in the longitudinal direction. A vessel will trim about the center of area for the waterline area, also known as the longitudinal center of buoyancy, LCB. When a mass is placed on the vessel, the extra buoyancy that develops from the vessel being lowered deeper into the water will attack in the LCB. If the mass is placed in the same horizontal position as the LCB, the vessel will maintain parallel submersion. However, if the mass is placed away from this position, the mass will generate a moment ( $M$ ) around the LCB. This moment is called the trim moment and results in a longitudinal trim angle ( $\theta$ ).

### 3.3.4 Technical Drawings

#### Lines Plan

The lines plan drawing consist of three different drawings; the body plan, the half-breadth plan and the sheer plan. The body plan shows the stations of the vessel, which are the intersection lines between the hull and transverse vertical planes. The half-breadth plan shows the waterlines, which are the intersection lines between the hull and a set of horizontal planes at different heights. The sheer plan shows the buttocks, which are the intersections lines between the hull and longitudinal vertical planes. The drawing helps

define the shape of the hull, as well as setting the boundaries for other drawings. An experienced engineer can use the drawings to get an impression of the hulls' complexity, and the amount of work required to produce the hull. The drawings give an impression of how much of the midship is parallel, and the curvature of the hull. (Hagen, 2016)

### **General Arrangement**

The general arrangement (GA) identifies the placement of decks and bulkheads, and gives a general placement of main equipment at each deck of a vessel. It can be used to ensure that all equipment on the vessel has sufficient space. The GA is used as reference for other drawings to find positions and distances. It also shows open areas and routes on the vessel.(Hagen, 2016)

### **Midship Section**

The midship section drawing describes the cross section of chosen frames, with their dimensions and placement of structural elements. It shows plate thicknesses, profile scantlings and the placements of these. It gives the dimensions of the frames in question. The drawing also gives an impression of the complexity and configuration of the hull structure. Based on these drawing, an estimate of the structure weight and cost can be calculated. Strength calculations can also be performed based on these drawings. (Hagen, 2016)

### **System Scheme (P&ID)**

These drawings, commonly referred to as process and instrumentation diagrams, defines the functional composition and general placement of different components in a system. They identify major components with their performance specifications and required dimensions of pipes and armatures.(Hagen, 2016)

### **One-line Diagram**

The one-line diagram shows the main electrical consumers and their associated power demand. These drawings are the basis for the design of the main switchboard. It shows the cabling between consumers and producers, as well as the need for electrical armatures and components like connectors, switches and relays. The drawings gives an indication of where the cabling has to penetrate the bulkheads. (Hagen, 2016)



## 4 Methodical Approach

This dissertation is a study to find the best possible design for the passenger ferry that is to operate between Ravnkloa and Fosenkaia, in Trondheim. The ferry will be named Ellen AuTomine. This name was chosen because it reflects the fact that the ferry is both electric and autonomous. In order to find the best possible design, the appropriate methodology must be set.

### 4.1 Determination of Design Method

Section 3.1 describes three different design methodologies relevant for this study. This includes the traditional marine design methodology, SBSD and RBSD. The traditional marine design approach is initiated by looking at an already existing vessel of the same type as the vessel to be designed. The approach is to move from mission to form. If the goal is to design a vessel similar to other existing vessels, this methodology may be appropriate. The challenge of using the method is that the design used as basis may be flawed. The designer will then risk bringing flaws or weaknesses into the new design if these are not discovered. The SBSD methodology does not use existing vessels as basis for its design. The method is initiated by determining the relevant functions for the product. Using this approach will increase the opportunity for innovation and new solutions, as it enables the designer to look at several alternatives. Further, the designer can focus on good alternatives, rather than being locked to one concept from the start. The methodology moves from mission, through function to form. Using this methodology, the designer cannot lean on previous designs. The challenge is therefore to not make any miscalculations and include them in the design.

The RBSD methodology is not really a complete design methodology in itself as it only sets the approach up til the concept development stage. The purpose of this methodology is to determine relevant functional requirements related to safety, in order to prove that a new solution is at least as safe as required by existing regulations, even though it does not fulfill them. In this way, the method allows for innovation and development. The approach is not an approved method, and the design would also need to satisfy relevant regulations in order to be approved by the Norwegian Maritime Authority.

The autonomous system that is to control the vessel is not yet developed, and will likely set several functional requirements to the design that are not yet present in existing vessels. Therefore, RBSD will be part of the methodology applied in this study. Further, no comparison vessels are available, making the traditional marine design approach unsuited for the task. The SBSB methodology will be the best alternative, as it will be a necessity to determine the necessary area and volume on board before designing the hull and superstructure. This is because no valid indications on the required space exists. The SBSB method is also well suited for integration with the RBSD methodology, as both methods are focus on designing from function to form. When applying the two methods in this thesis, functional analysis will be used to a higher degree than what is typical. This because the development of new designs give the best result if the functionality of the product is used as basis, instead of assuming the physical design based on existing vessels. The required functions set in the RBSD may simply be included in the SBSB approach, as the RBSD do not define the design approach further after the required functionality is set. It may be time consuming to determine the safety related requirements as a complete risk assessment will be necessary. Still, as there are no approved regulations available for autonomous vessels, it will be beneficial to evaluate the safety in its entirety to ensure that the autonomous features are accounted for. Based on these discussions, it was concluded that the best design approach will be to use the SBSB method, with inputs from RBSD. This will help secure a well thought out design, were the safety aspects are thoroughly considered.

## 4.2 Description of Methodical Approach

The work follows the SBSB methodology combined with the RBSD method. In order to apply both methods simultaneously in this study, they had to be modified to fit the task. The two methods are in figure 11 presented separately in two columns with arrows indicating how they are related in the study. As apparent from the figure, the SBSB methodology applied in this study is somewhat altered from the traditional SBSB design spiral. This is to better illustrate the functional analysis that is part of the approach, as this is poorly included in the original illustration made by Professor Kai Levander (see figure 5) but still an important part of the method.

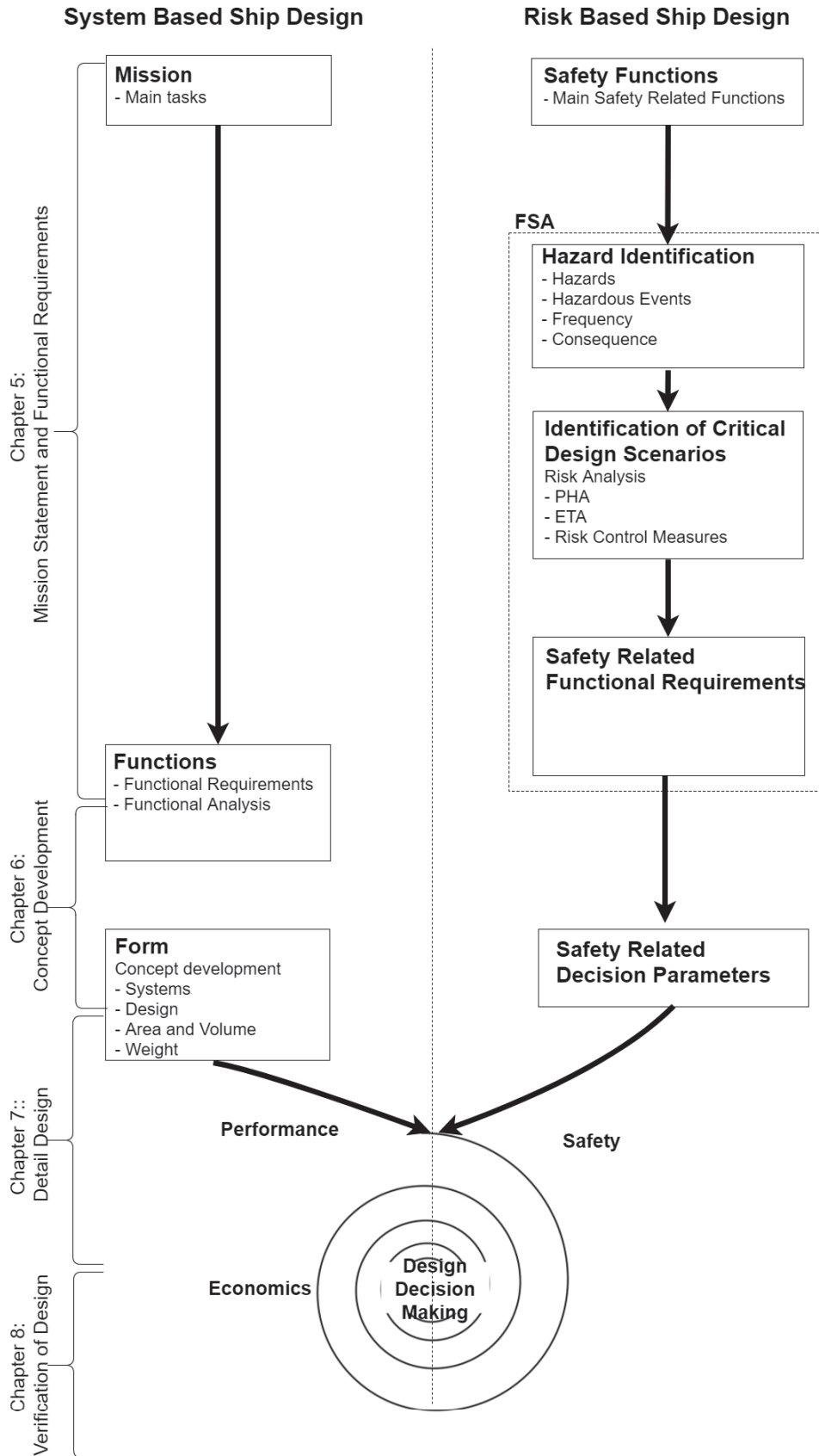

Figure 11: Illustration of the SBSD method combined with the RBSD

The design starts with the mission statement, as is normal practise when using the SBSB method. This includes stating the main task in the project. Following this, the relevant main functions are set considering what is directly related to performing the main task. The RBSB methodology is here introduced to include the safety related main functions. These will be similar to the generic main functions, but focus only on operational safety. Based on the main functions, relevant functional requirements may be set. These requirements will be essential for enabling the design to perform the main functions. In order to determine the safety related functions, a FSA will be performed. This assessment will cover both the hazard identification and the identification of critical design scenarios as illustrated in the figure. The risk assessment will result in safety related functional requirements necessary to fulfill the safety related functions. The illustration of the methodology in figure 11 also illustrates which part of the design process is covered by the different chapters. Some of the tasks will extend over multiple chapters. As seen from the figure, the functional requirements are set in chapter 5.

Once all relevant functional requirements are set, the concept developments may be initiated. A brainstorming session will be performed and all possible solutions noted. The alternatives will be continuously evaluated against relevant framework conditions. The least relevant ones will be excluded, thus limiting the final solution throughout the design process. This process is noted as form in figure 11. The concept development will be performed before using the SBSB template to determine the required area and volume on board the vessel. Following the volume determination, the hull shape and superstructure will be designed before the complete design is evaluated. The weight of the vessel will be continuously estimated based on the information available. The last step of the RBSB method is to use the safety related functional requirements as an extra set of decision parameters in the design process. The concepts and final design will therefore be evaluated not only on technical performance and economy, but also on safety performance. This is the reason why safety is included in the design spiral in figure 11, illustrating the determination and evaluation of the final design. Normally, the SBSB methodology considers only performance and economics. The safety is then included in the performance aspect, together with others. In this combined methodology, safety is considered equally important as economics and performance, due to the RBSB involvement. The final design will thus be verified using various methods related to both economics, performance and



safety. It will be designed to fit the relevant external conditions and limitations present in the best possible way. The evaluation methods that will be applied include stability- and strength calculations, resistance calculations and life cycle cost estimates. Figure 12 below illustrates the methodical approach applied in this study. It shows more clearly than figure 11 how the two methodologies are combined into one clear approach.

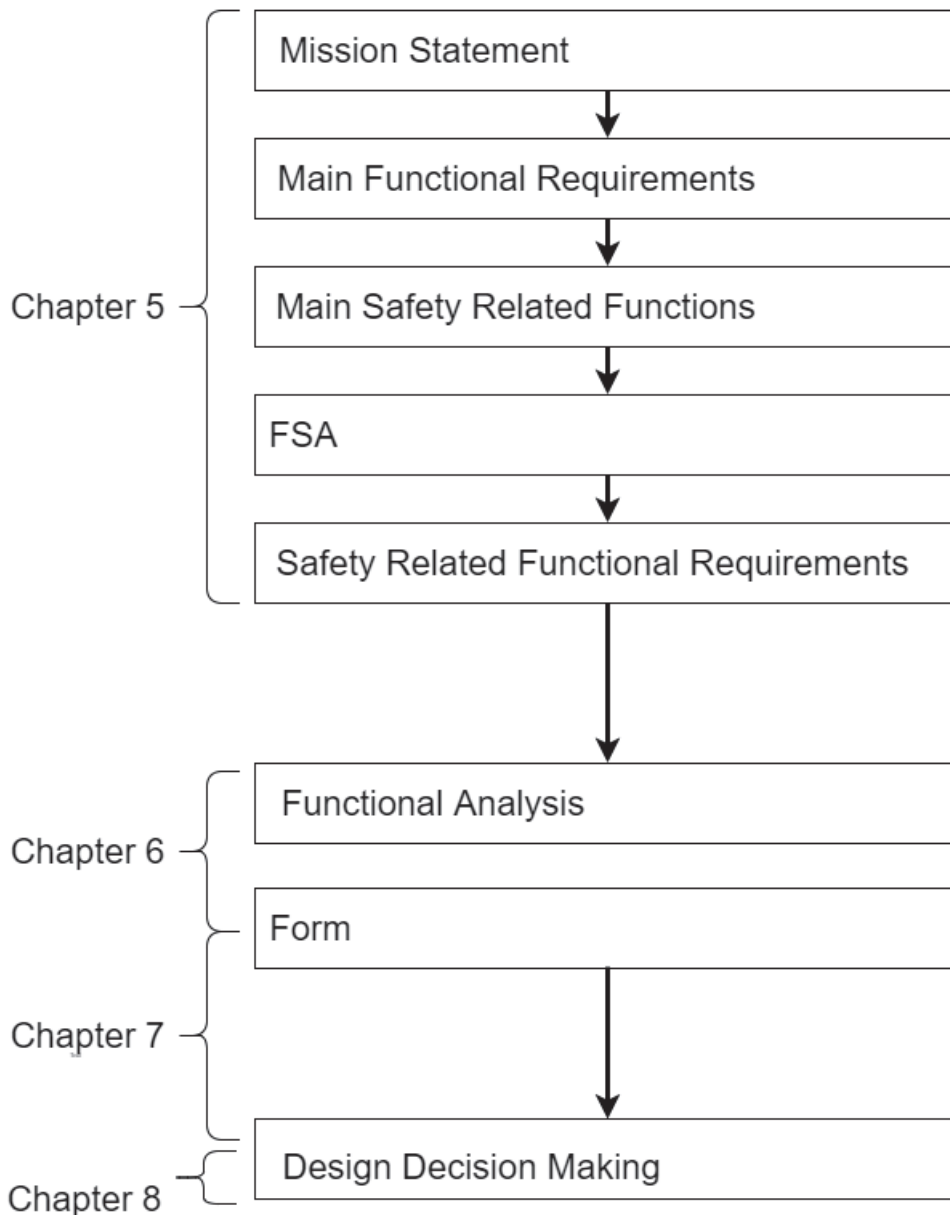

Figure 12: The combined SBSD-RBSD methodology used in this thesis



## 5 Mission Statement and Functional Requirements

This chapter will discuss the mission statement and the determination of all relevant functional requirements for the final design product. As illustrated and described in the previous chapter, the SBSD and RBSD methodologies will in combination set these requirements. The generic functional requirements will be determined first, based on the mission statement for the project. Following this, the generic requirements related to safety will be set, before examining the safety related functional requirements supporting them. These will be determined using a formal safety assessment.

### 5.1 Mission Statement and Main Functions

The main task in this study is to design an autonomous surface vehicle for transporting people across the channel between Ravnkloa and Fosenkaia in Trondheim. This mission statement was based on the project goal set by project manager, Egil Eide. It reflects what is the focus of the design process and what aspects are a mandatory part of the result. Several functional requirements are relevant for the resulting product, based on the mission. The main functional requirements for the product of this study are as follows.

- Be able to transport 12 passengers and 12 bicycles
- Be able to reach the maximum speed of five knots
- Be able to operate for the required number of hours in all feasible temperature conditions.
- Be able to replace a bridge in the area to a reasonable degree
- Be able to transport all types of pedestrians (wheelchair users, strollers etc.)
- Be able to provide a high level of passenger comfort
- Be able to navigate autonomously without need for human assistance
- Be able to dock autonomously without the need for human assistance
- Be able to maintain high efficiency for passengers using the ferry (easy access, user friendly, high availability etc)

## 5.2 Safety Related Functions

The safety related functions were divided into two main categories; the top-level functions describing the generic safety functions for the product, and the specific technical functions, supporting the top level functions. The primary focus when determining the safety functions was the safety and comfort of passengers. The NBS was reviewed to detect statutory requirements defining relevant safety functions. The primary focus was on the ferry itself, as this will be the product of this study. The dock and area surrounding the ferry was also considered, but with less emphasis. Structural and operational aspects of the ferry were considered more relevant than the building related safety. This because the design and operation was the primary focus of this study. The building will be more relevant at later stages of the ferry project. The complete list of safety related functions is presented below.

### Top level Functions

- Be able to avoid accidents (grounding, collision etc.) leading to total ship loss
- Be able to avoid loss of human life due to ship related accidents
- Be able to avoid loss of human life due to dock related accidents
- Be able to avoid a large impact on the environment in case of accident

### Specific Technical Functions

- Be able to remain upright and afloat in all feasible loading conditions
- Be able to avoid flooding of vessel
- Be able to withstanding all foreseeable loads during lifetime
- Be able to keep the operational speed and navigate correctly in all feasible loading conditions
- Be able to limit the number of passengers automatically without the need for human assistance

A preliminary concept was determined based on the mission statement and functional requirements. It describes what was known about the ferry and its design at this stage, before the risk assessment and subsequent concept development process was to be initiated. It includes that the ferry is autonomous with a capacity of 12 passengers and 12 bicycles. It can operate without the need for personnel present on board or at the dock. It has the possibility of operating on demand with use of a call button, like on an elevator. The ferry was assumed equipped with an emergency anchor, life jackets for all passengers, an emergency stop button and a fire extinguisher in case of fire on board. The emergency stop button would stop the ferry transit if triggered.

### 5.3 Formal Safety Assessment

The next steps following the RBSD approach is to identify hazards, identify critical scenarios, and the definition of functional requirements. To do this a risk assessment has been performed, following IMO's formal safety assessment guidelines as described in section 3.1.5. It was a qualitative assessment with quantitative values, using descriptive scales and words that are represented by a quantitative value. The results from the FSA was used to define a set of functional requirements for the final design to make sure it is as safe as possible.

#### 5.3.1 Hazard Identification

The hazard identification was performed using the PHA method. The first step was to plan and prepare the analysis. The objective and boundaries, the analytic approach and the study team were determined. All available and necessary background information was also found. An overview of the preparations made can be seen in appendix B.1.

The next step was the identification of hazards and hazardous events. To make it easier to identify all the hazards a hazard checklist was applied in a brainstorming session. Three hazard categories were considered; external hazards, functional hazards and system hazards. Mind maps were made during the session, two for each hazard category. These can be seen in appendix B.2. Two different checklists were used, a generic checklist from Rausand (2013) and the ISO standard 12100 *Safety of machinery* (Standard Norge, 2010).

When all the hazards were identified, they were entered into a PHA worksheet sorted after the system element or activity related to the hazard. Once the hazards and hazardous events were determined, the sequence of events was defined. The PHA worksheet defines both the hazardous event (what, where, when), cause of the hazardous event (triggering event) and the consequence of the event (harm to what).

Once the sequence of events had been set, the frequency and consequence of the different hazardous events were set. To do this, frequency and consequence categories had to be defined. In this study, the categories that are used were derived from chapter 4.8 and 4.9 in Rausand (2013). Three different types of consequences were considered; people, environment and property. The categories for frequency can be seen in table 4, and the categories for consequence can be seen in table 5.

Table 4: Description of frequency categories used in the PHA

| Category        | Frequency(per year) | Description   |
|-----------------|---------------------|---|
| 5 Fairly normal | 10 - 1              | Event that is expected to occur frequently  |
| 4 Occasional    | 1 - 0.1             | Event that happens now and then and will normally be experienced by the personnel |
| 3 Possible      | 10E-01 - 10E-03     | Rare event, but ill possibly be experieced by the personnel                       |
| 2 Remote        | 10E-03 - 10E-05     | Very rare event that will not necessarily be experienced in any similar plant     |
| 1 Improbable    | 0 - 10E-05          | Extremely rare event  |

Table 5: Descriptopn of consequence categories used in the PHA

| Category       | Consequence types                                  |  |  |
|----------------|--|--|--|
|                | People   | Environment  | Property   |
| 5 Catastrophic | Several fatalities                                 | Time for restitution of ecological resources $\geq 5$ years    | Total loss of system and major damage outside system area      |
| 4 Severe loss  | One fatality                                       | Time for restitution of ecological resources = 2-5 years       | Loss of main part of system; production interrupted for months |
| 3 Major damage | Permanent disability, prolonged hospital treatment | Time for restitution of ecological resources $\leq 2$ years    | Considerable system damage; production interrupted for weeks   |
| 2 Damage       | Medical treatment and lost-time injury             | Local environmental damage of short duration ( $\leq 1$ month) | Minor system damage; minor production influence                |
| 1 Minor damage | Minor injury, annoyance, disturbance               | Minor environmental damage                                     | Minor property damage  |

Once the frequencies and consequences were set, the RPN was determined as the sum of the frequency and the consequence. The RPN was then used to determine whether the hazard was acceptable or not. This was done by comparing the RPN with a predetermined risk acceptance criteria, based on the ALARP principle. In this study RPN equal to 1-5 is in the acceptable region, RPN equal to 6 and 7 is in the ALARP region and RPN equal to 8, 9 and 10 is in the unacceptable region. This has been illustrated in the PHA (found in appendix F) by colour, where green is acceptable, yellow is the ALARP region and red is unacceptable. When all the risk had been assessed, risk reducing measures were suggested. These suggestions were considered in the further risk assessment as possible ways to remove or mitigate risks that were unacceptable, or in the ALARP region.

### 5.3.2 Identification of Critical Design Scenarios

In the PHA, eight hazardous events were in the unacceptable region. These are summed up in table 6. To be able to reduce the risk these events pose, they were further analyzed by using FTA and ETA. The hazardous events are the top events in the FTAs and the initiating events in the ETAs.

Table 6: Hazardous events in the unacceptable region

| Number | Hazardous Event                   |
|--------|-----------------------------------|
| 1      | Emergency stop failure            |
| 2      | Failure in passenger registration |
| 3      | Fire on vessel                    |
| 4      | Loss of navigational control      |
| 5      | Not enough life jackets           |
| 6      | Person in water                   |
| 7      | Slippery dock                     |
| 8      | Vessel stolen                     |

The FTAs were constructed using software CARA FaultTree. All basic events were given probabilities, and the probability of the top events were calculated from these. The numerical values of the probabilities were chosen by using a qualitative scale, given quantitative values. The scale is shown in table 7. All the FTAs can be seen in appendix B.3, and all the values of the basic events can be seen in appendix B.4.

Table 7: Probability categories used for FTA

| Category      | Probability    |
|---------------|----------------|
| Remote        | 0 - 0.0049     |
| Possible      | 0.005 – 0.0999 |
| Occasional    | 0.1 – 0.4999   |
| Fairly normal | 0.5 - 1        |

When the FTAs were constructed, ETAs were made for the same hazardous events. These were constructed using Excel. Each event in the ETAs sequence of events was given a probability. As it uses a binary principal, the probability of the different events that can occur on each level equals one. The probabilities and frequencies of all consequences were calculated further. The ETAs can be seen in appendix F. The probabilities in the ETA and FTA are all set based on the teams intuition. Optimally the probabilities should be set based on statistics, or with the help of an experts judgment. This represents a source of error in the risk assessment.



### 5.3.3 Risk Control Options

Based on the suggested RCMs in the PHA and an evaluation of the FTAs and ETAs, twenty RCMs were further investigated. The risk control measures considered can be seen in table 8.

Table 8: Possible alternative risk control measures

| <b>Initiating Event</b>           | <b>Risk Control Measure</b>                       |
|-----------------------------------|---|
| Slippery dock                     | Heat cables in dock floor                         |
| Slippery dock                     | Person hired to clear dock of snow/ice            |
| Slippery dock                     | Fencing around dock                               |
| Vessel stolen                     | Person on land supervising the ferry more closely |
| Vessel stolen                     | Tracker on ferry                                  |
| Person in water                   | Unclimbable structure                             |
| Person in water                   | Ladder or net on the outside of the vessel        |
| Loss of navigtional control       | Inaccessible sensors to avoid tampering           |
| Loss of navigtional control       | Increased damage stability                        |
| Loss of navigtional control       | Strengthened hull                                 |
| Emergency stop failure            | Proper design of emergency stop button            |
| Emergency stop failure            | Increased damage stability                        |
| Emergency stop failure            | Strengthened hull                                 |
| Fire on vessel                    | Redundancy in fire system                         |
| Fire on vessel                    | Alarm that alerts the fire department             |
| Fire on vessel                    | Extra fire extinguisher                           |
| Fire on vessel                    | Flammable material on ferry limited               |
| Not enough life jackets           | Regular check, and restock of life jackets        |
| Not enough life jackets           | Fine for stealing life jacket                     |
| Failure in passenger registration | Extra barrier in registration system              |

To get an idea of what effect these RCMs would have, the changes were included in the ETAs and FTAs. The risk reductions reduced the probability and frequency of the top and end events. The new risk reduced ETAs show the initial values, new values and percent change in risk. The updated ETAs can be seen in appendix F.

### 5.3.4 Cost Benefit Analysis

When the RCMs had been suggested, and the resulting changes determined, a cost benefit analysis was performed to determine which of the measures should be implemented in the design. The disproportionality factor for this study was set equal to one, which implies that the costs have to be equal to/or smaller than the value of the benefits. Whether a measure is beneficial or not is decided by equation 15.

$$\frac{\text{Present value cost of measure}}{\text{Present value benefit of measure}} \leq 1 \quad (15)$$

The cost of the risk and the benefits had to be determined. The consequences considered in this CBA was loss of human life, and loss of vessel. The value of a human life was set to USD 9 mill, equal to approximately NOK 76 mill (Partnoy, 2012). The value of the vessel was set to NOK 1.5 mill. The value of the benefit was then calculated based on the cost of the risk. First, the cost of the risk per year was calculated as the cost multiplied with the probability of the risk occurring. The probability was then reduced by the RCM considered. This gave a new cost of risk per year. The value of the benefit is then calculated as the difference between the original cost of risk per year minus the new cost of risk per year. Next, the cost of the RCMs was set. This included the investment costs and operation costs over the lifetime of the vessel.

Next, the present value of the benefit and costs were determined. To do this, an interest rate was chosen. The British Government base their interest rate on the social time preference rate. This rate is commonly in the range 2% - 6%. For this study a rate of 5% was chosen. When the present values were calculated, the cost benefit ratio was calculated and compared to the disproportionality factor. A summary of the results from the CBA can be seen in table 9. The full CBA can be seen in appendix B.5.

Table 9: Summary of the result from the cost benefit analysis

| <b>Risk control measure</b>                       | <b>Cost Beneficial?</b> |
|---|-------------------------|
| Heat cables in dock floor                         | Yes                     |
| Person hired to clear dock of snow/ice            | No                      |
| Fencing around dock                               | Yes                     |
| Person on land supervising the ferry more closely | No                      |
| Tracker on ferry                                  | Yes                     |
| Unclimbable structure                             | No                      |
| Ladder or net on the outside of vessel            | Yes                     |
| Inaccessable sensors to avoid tampering           | Yes                     |
| Increased damage stability                        | No                      |
| Strengthened hull                                 | Yes                     |
| Proper design of emergency stop button            | Yes                     |
| Increased damage stability                        | Yes                     |
| Strengthened hull                                 | Yes                     |
| Redundancy in fire system                         | Yes                     |
| Alarm that alerts the fire department             | No                      |
| Extra fire extinguisher                           | Yes                     |
| Flammable material on ferry limited               | Yes                     |
| Regular check, and restock of life jackets        | No                      |
| Fine for stealing life jacket                     | Yes                     |
| Extra barrier in registration system              | No                      |

As can be seen from the table, the RCM that improves the damage stability is cost beneficial in the emergency stop failure ETA, but not for the loss of navigational control. This is due to how much the RCM reduces the risk in both cases. For the case of the autonomous vessel, it has been recommended to have safety measures for floating ability by the Norwegian Maritime Authority (Medhaug et al., 2017). The improvement of the stability should therefore be considered. The alarm that alerts the fire department was considered not cost beneficial, as the fire department has to be paid to show up. This expense could somewhat be covered by fining passengers who trigger the fire alarm when not needed. All the risks considered had one or more RCMs implemented, as required.

In a regular CBA, the hazards in the ALARP region should also be considered. By implementing the RCMs above, many of the ALARP risks have already been reduced. The remaining ALARP risks should still be investigated and considered reduced. An example is the situation with ice on the deck of the ferry. This risk is considered ALARP, and could easily be reduced by implementing heating cables in the deck of the ferry. Another example is the risk associated with stormy weather. It can be considered to stop

the ferry at a predefined wind speed limit. Still, some ALARP risk have to be accepted. The risk of a terrorist attack had to be accepted, as there is little to be done to prevent it. The team did not look any closer at the ALARP risks, but some of them will still be relevant in the further design process.

### **5.3.5 Safety Related Functional Requirements**

The safety related functional requirements, resulting from the critical design scenarios in the risk assessment, will be essential to be able to fulfill the generic safety functions. They function as an extra set of decision parameters when determining the final design. The ferry concept developed in the further work must satisfy all relevant requirements in order to perform as intended. The safety related functional requirements are presented in the list below.

- Prevent passengers from climbing on the ferry roof
- Prevent passengers slipping on the dock
- Prevent the vessel being stolen
- Prevent man over board
- Minimize the consequences in case of man over board
- Prevent loss of navigational control during operation
- Minimize consequences if loss of navigational control occurs
- Prevent failure of emergency stop system (failure to use and technical failure)
- Prevent fire on board
- Minimize consequences of fire on board
- Prevent too few life jackets on board
- Prevent failure in the registration of passengers entering the ferry

## 6 Concept Development

This chapter will discuss the work related to transforming the functional requirements into the physical form of the design, as discussed in the methodical approach description. The concept development was initiated through a brainstorming session. The purpose of which was to discover all possible solutions that fulfill the main function. Evaluations of the solutions will be made using various ranking methods, limiting the design space. The initial concept is set through the brainstorming, before the hull shape is considered. Further, the docking will be evaluated and the mooring solution determined before relevant considerations with regard to safety and design are discussed. Finally, the dock layout is set and the required area and volume on board will be investigated using life size - and model testing. The results will be used to fill out the SBSB template and determine the initial displacement of the vessel.

### 6.1 Functional Analysis and Possible Solutions

The essential sub-functions of the ferry were determined through a functional analysis. The mission statement for the project was used as basis. The analysis continued with a new brainstorming session to detect possible solutions that fulfill these functional requirements. The results from this analysis session is illustrated in appendix C.1. These possible solutions may be combined in any number of ways to create the ferry design. To limit the number of possible concepts, the solutions were evaluated in three steps. First, the solutions that were considered unacceptable or infeasible were eliminated from further evaluation. The remaining solutions were then compared on the basis of qualitative cost and feasibility considerations. Finally, the preliminary design concept was determined based on the remaining solutions' usefulness, cost and safety level (Erichsen, 1999). The possible solutions eliminated during the first round are presented in table 1 in appendix C.2. The solutions were eliminated because they were considered infeasible or unacceptable. The table the arguments of their removal. After the most irrelevant solutions were removed, the remaining ones were mixed in a morphological combination. Here, each solution is combined with all possible solutions in the other sub function - categories to

ensure that all possible concepts are considered. Each combination is a possible design solution that may be further developed. An illustration of the combinations can be found in figure 13.

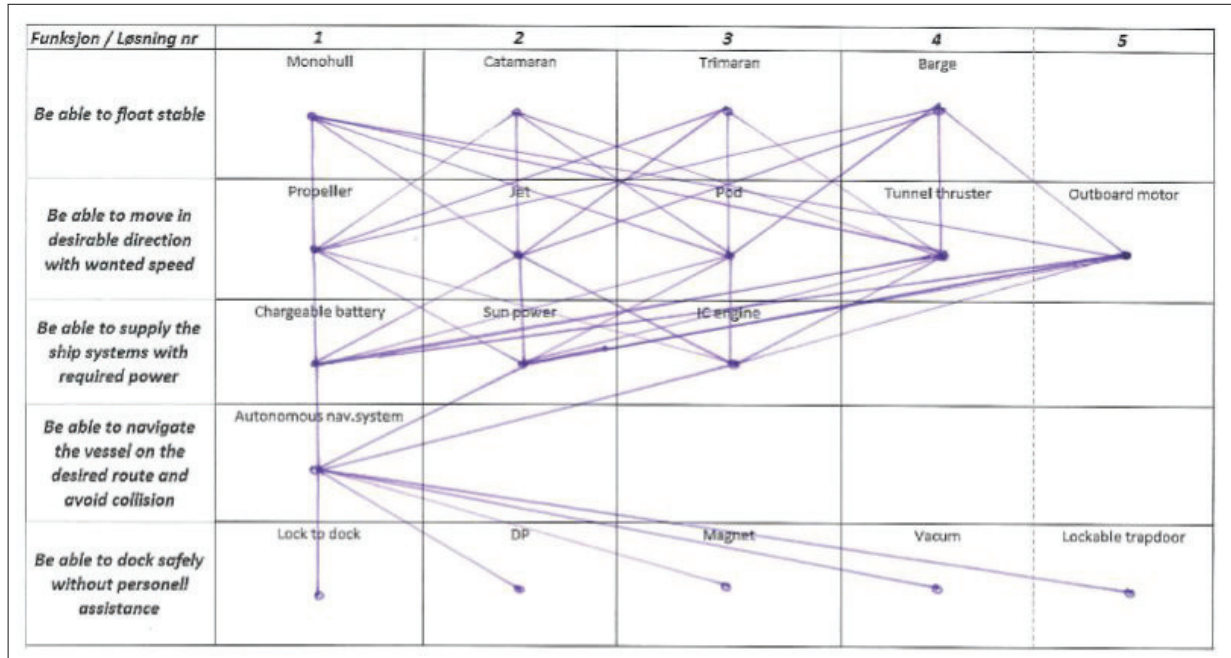

Figure 13: Possible solutions after elimination round one in morphological combination

The second round of eliminations limited the number of concepts further. Both elimination rounds were based on the team members' previous knowledge and intuition. The solutions removed from further evaluation in round two included barge as hull shape, outboard motor for propulsion, sun power as power supply and DP as docking solution. DP was only removed as a docking solution, as it will be a necessary system for the autonomous functionality to work. It may function as an emergency system if the docking system fails. A summary of the solutions removed and the reasoning for their removal is found in table 2 in appendix C.2. Completion of elimination round two resulted in 72 possible concepts. These are illustrated in figure 14.

The remaining concepts were further listed in a table for better overview and considered either feasible or not in the final evaluation round. The listing of the concepts are found in table 10. Supplementary information on suitability for the task in question, costs and safety was necessary to evaluate the concepts further. The concepts eliminated in the final round are presented in table 3 in appendix C.2. They will also be discussed in detail further in this section.

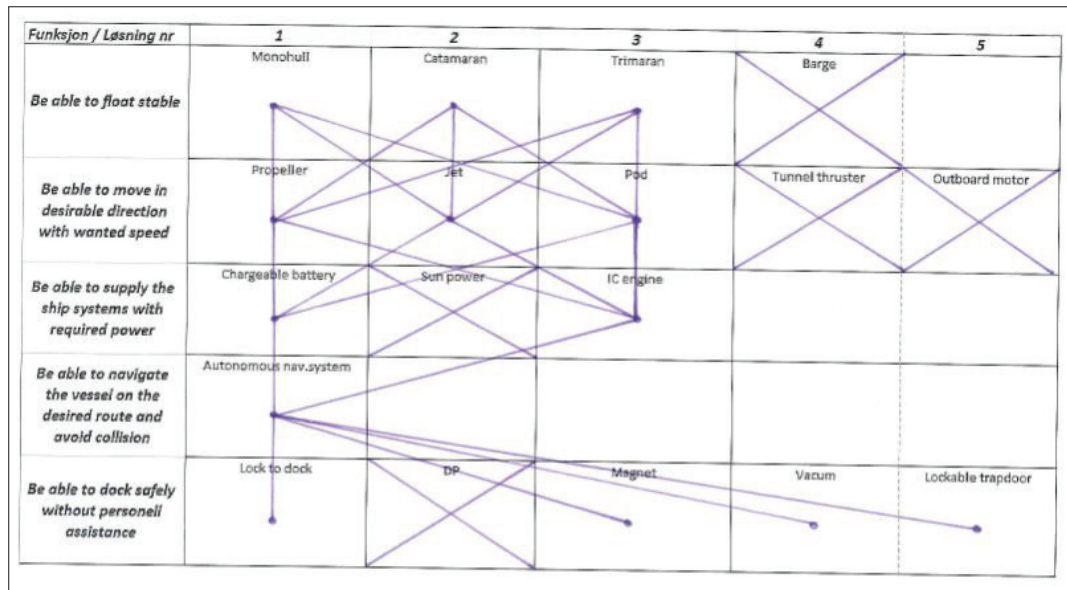

Figure 14: Possible solutions after elimination round one in morphological combination

Table 10: Remaining solutions to the functional requirements after elimination round 2

| Float stable | Propulsion  | Navigate    | Supply power       | Dock safely                                     |
|--------------|-------------|-------------|--------------------|---|
| Monohull     | Propellers  | Auton. nav. | Battery, IC Engine | Lock to dock, Magnet, Vacuum, Lockable trapdoor |
| Monohull     | Jet         | Auton. nav. | Battery, IC Engine | Lock to dock, Magnet, Vacuum, Lockable trapdoor |
| Monohull     | Pod/Azimuth | Auton. nav. | Battery, IC Engine | Lock to dock, Magnet, Vacuum, Lockable trapdoor |
| Catamaran    | Propellers  | Auton. nav. | Battery, IC Engine | Lock to dock, Magnet, Vacuum, Lockable trapdoor |
| Catamaran    | Jet         | Auton. nav. | Battery, IC Engine | Lock to dock, Magnet, Vacuum, Lockable trapdoor |
| Catamaran    | Pod/Azimuth | Auton. nav. | Battery, IC Engine | Lock to dock, Magnet, Vacuum, Lockable trapdoor |
| Trimaran     | Propellers  | Auton. nav. | Battery, IC Engine | Lock to dock, Magnet, Vacuum, Lockable trapdoor |
| Trimaran     | Jet         | Auton. nav. | Battery, IC Engine | Lock to dock, Magnet, Vacuum, Lockable trapdoor |
| Trimaran     | Pod/Azimuth | Auton. nav. | Battery, IC Engine | Lock to dock, Magnet, Vacuum, Lockable trapdoor |

The evaluations concluded that concepts including trimaran hull were to be excluded from further consideration. The option is feasible, but the benefits of the concept does not weigh up for the drawbacks. Trimarans have good directional stability due to larger draught than for a monohull vessel. This may also be achieved by a catamaran hull. It distinguishes itself from the catamaran having better longitudinal stability due to its centred third hull. Still, three hulls result in a large surface and hence much friction and resistance. The benefit of a small surface in the water is therefore limited. In addition, the large draught will make the ferry more exposed to currents in the channel. To overcome the resulting forces, it needs to maintain high speeds (Nicolaysen, 2017). As this is not an option for the ferry in this study, due to speed limitations in the channel, the alternative was considered less optimal.

It was further concluded that the jet propulsion system would not be feasible. Jet propulsion systems are common in small high-speed ferries, and when other propulsion alternatives are ruled out. Despite their manoeuvrability and short stop length, the system is heavier than conventional propulsion systems and is thus preferred on larger ferries than in this study (Carlton, 2011). Another propulsion alternative ruled out was the conventional propeller. The idea was one propeller in each end of the vessel to avoid it turning for each trip. Propellers are considered more reliable than pods. This option was ruled out as its navigational abilities are significantly lower than in the case of podded propulsion. In addition, the propellers need to be continuously adjusted to each other to prevent interference when crossing the channel back and forth. It will therefore demand adjustable propellers and higher costs (Steen, 2017).

The internal combustion (IC) engine was removed from further evaluation because the logistics concerning the option would be unnecessarily complicated. Using an IC engine would require personnel or an automated system, not yet developed, to refuel. The safety level is considered lower than for the alternative of a battery due to fire hazards. Life cycle analysis reports also conclude that power supply using a battery will be more environmentally friendly. Electrical vehicles that use average electricity mixes generally perform better than diesel and gasoline vehicles for greenhouse gas (GHG) emissions. At the same time, they perform somewhat worse in categories like toxicity and eutrophication. This is because of the toxic materials used in the batteries for the electric vehicle. The electricity mix that the vehicles use is very important for the result. If the electricity



is produced using fossil fuels the electric vehicle will have higher GHG emissions than than diesel and gasoline vehicles. Electricity produced with renewable energy will have a significantly lower emission. (Kullmann et al., 2016)(Nicolay, 2000)(Pedro Marques and Freire, 2013)(Helms, 2010)(Hawkins et al., 2012)(Girardi et al., 2015)(Choma and Ugaya, 2015)

The remaining possible concepts are presented in table 11 below. The alternatives will in the following sections be evaluated to determine the hull shape and mooring solution of the final design concept.

Table 11: Remaining solutions to the functional requirements after elimination round 3

| <b>Float Stable</b> | <b>Propulsion</b> | <b>Supply Power</b> | <b>Navigate</b> | <b>Dock Safely</b> |
|---------------------|-------------------|---------------------|-----------------|--------------------|
| Monohull            | Pod/Azimuth       | Battery             | Auton. nav.     | Lock to dock       |
| Monohull            | Pod/Azimuth       | Battery             | Auton. nav.     | Magnet             |
| Monohull            | Pod/Azimuth       | Battery             | Auton. nav.     | Lockable trapdoor  |
| Catamaran           | Pod/Azimuth       | Battery             | Auton. nav      | Lock to dock       |
| Catamaran           | Pod/Azimuth       | Battery             | Auton. nav      | Magnet             |
| Catamaran           | Pod/Azimuth       | Battery             | Auton. nav      | Lockable trapdoor  |

## 6.2 Determination of Hull Shape

Sketches were made to determine how the two hull shape alternatives would function and the pros and cons of both were discussed to rank the options. The sketches, found in appendix C.3, looks at both the possible arrangement of system parts and the ferry's interaction with the surroundings. The ranking method is based on a similar investigation performed by Thomas et al. (2007). Their report on how to choose between a high-speed catamaran and monohull looks at comparison methodologies relevant to decide between the two. Both economic and technical methodologies are described. This thesis made use of their suggested technical methodology, ranking the two options according to relevant factors adapted to fit the problem relevant in this thesis. A case study of the method is presented in their report (Thomas et al., 2007). This was used as basis for the evaluation of the hull shape. Relevant changes were made to the evaluations where it was found necessary. The complete scheme is still included. As the study object in the report is a high-speed vessel with a different operational profile, not all arguments were relevant to this study and the result could therefore not be used directly. In addition to this report,

“On the Great Trimaran-Catamaran Debate” by Doctors (2017) and input from Sven Ole M. Nicolaysen was used to support the evaluations.

The first stage of the ranking was to determine the max weighting of the evaluation criteria. Each criterion was given a weighting between zero and ten, based on how relevant it was for the autonomous ferry’s operation. The evaluation criteria were divided into five main categories consisting of payload capacity, passenger comfort, environmental, operational capability, safety and other attributes. The maximum weighting in each category is listed with its name for better overview. Environmental and safety related criteria were weighted zero as there were no environmental restrictions known at this stage and the safety level would need to be equally good in both cases. The motions of the vessel, manoeuvrability, course keeping, speed loss, calm water speed, aesthetics and battery redundancy was weighted ten. These were the criteria considered most relevant for the vessels performance. The complete ranking with all weightings can be seen in table 12.

Table 12: Ranking of hull shape alternatives

| CRITERION               |            | VESSEL ONE | VESSEL TWO |
|-------------------------|------------|------------|------------|
|                         | MAX WEIGHT | MONOHULL   | CATAMARAN  |
| <b>PAYLOAD CAP.</b>     | 7.5        |            |            |
| Deck Area               | 7.5        | 6          | 7.5        |
| Volume                  | 1.5        | 1.5        | 0.5        |
| <b>PASS. COMFORT</b>    | 10         |            |            |
| Motion (MSI)            | 10         | 8          | 4          |
| Noise and Vibrations    | 2.5        | 2.5        | 1          |
| <b>ENVIRONMENTAL</b>    | 0          |            |            |
| Wave wake               | 0          | 0          | 0          |
| <b>OPERATIONAL CAP.</b> | 10         |            |            |
| Manouverability         | 10         | 10         | 8          |
| Docking                 | 7.5        | 6.67       | 3.33       |
| Course keeping          | 10         | 6          | 4          |
| Refit Flexibility       | 0          | 0          | 0          |
| Speed Loss to sea state | 10         | 5          | 5          |
| Calm Water Speed        | 10         | 9          | 6          |
| <b>SAFETY</b>           | 0          |            |            |
| Trim                    | 0          | 0          | 0          |
| Intact Stability        | 0          | 0          | 0          |
| Damage Stability        | 0          | 0          | 0          |
| <b>OTHER</b>            | 9          |            |            |
| Aesthetics              | 9          | 5          | 5          |
| Battery redundancy      | 9          | 8          | 10         |
|                         |            |            |            |
| <b>TOTAL</b>            | 87         | 67.67      | 54.33      |
| %                       | 100 %      | 77.8 %     | 62.4 %     |

Further, the two hull alternatives were given a weighting between zero and ten according to each criterion, based on how well they perform in the relevant category. Ten would equal 100% performance. The number was then implemented with the weighting of the category to give the actual score. For instance, the deck area criterion had a maximum weighting of 7.5. When the monohull was considered to perform 80% in this category, the final score would be  $(\frac{7.5}{100}) \cdot 80 = 6$  points. The catamaran performing 100% received the maximum score of 7.5 in this category. The payload capacity was considered important for the choice of hull shape as it determines the possibility of transporting passengers. It would also affect the available space for equipment below deck. The deck area was considered the most important criterion in this category as sufficient space for the passengers were important. If the deck area is too small, the passenger comfort would decrease and they

may not use the ferry (Thomas et al., 2007). The catamaran scored better than the monohull because it would be able to keep the large beam of the midship all the way to the bow (Rudow, 2013). Volume was less important as it was assumed that the ferry would have sufficient volume below deck when the main deck was designed large enough. The monohull was considered superior in this category. There would be a risk that the catamaran hulls are too narrow at the ends so that the space becomes useless (Rudow, 2013). It would also be less complicated to plan the arrangement below deck when there is only one large room to consider. Two narrow hulls could possibly make the arrangement more complicated.

Passenger comfort was considered very important with maximum weighting of ten. The motion of the vessel was weighted 100% since it would determine how the passengers experience the ferry ride. As the currents in the channel will vary greatly and sometimes be strong due to the dam regulation at Trondheim Electric Plant, they may affect the passenger comfort (Havdal et al., 2016). Investigations from the preceding project thesis confirms that the current will hit the vessel from the side as it runs down the channel (Havdal et al., 2016). The monohull received twice as high score as the catamaran because the bow – quartering seas on the catamaran would cause a combined pitch and roll movement that is uncomfortable for the passengers. It would therefore be constantly in need of small adjustments (Falvey, 2004). The monohull will have lower acceleration from the waves and currents and will therefore feel more pleasant for the people on board. Noise and vibrations were considered less important with weighting of 25%. As the ferry ride would be approximately one minute, the passengers are less likely to be bothered by noise than if they needed to stay there for a longer time. It was still included as it is a relevant challenge if the noise were to be high. As the catamaran would give passengers a noisier ride due to its sharper movements, it received a total score of 1, while the monohull scored 2.5 (Parkinson, 2015). The environmental aspect was weighted as zero because the choice of hull shape will have insignificant effect on this. In addition, there are no known environmental restrictions in the operating area. Had there been, both hull shapes would need to comply to these regulations and it would have no effect on the choice.

Operational capability was considered very important as it may affect the travel time significantly. The manoeuvrability of the vessel was weighted 100% of the maximum weighting of 10 as it will be essential for keeping the ferry schedule. The monohull was

given a score of 10 and the catamaran a score of 8. The monohull received the higher score because it will be able to access more narrow areas than the catamaran due to its lower beam (Parkinson, 2015). The catamaran will benefit from the fact that its propellers would be placed far away from each other, enabling it to perform sharp turns in low speed. When using pods on a monohull, the same effect can be achieved and the advantage is therefore minimum (Rudow, 2013). The monohull will require more power to make sharp turns because of its high displacement in the water (Rudow, 2013), but the heel will be more comfortable than in the catamaran (Falvey, 2004).

The docking was considered slightly less important with a maximum weighting of 7.5. The monohull was set to be twice as good as the catamaran because it will require less space at the dock and will be easier to move onto land if necessary (Rudow, 2013). This because many cranes are available to transport monohull vessels around 8 metres as this is a common size of recreational vessels. Further, course keeping through the currents was considered very important as the directional stability would affect the ferry's ability to keep the route as short as possible. This will be important to maintain its schedule during the day. There are different opinions on the best option. The catamaran would have better directional stability at higher speeds (Nicolaysen, 2017), but will be more exposed to quartering seas and require small adjustments frequently (Falvey, 2004). When the weather and currents are calm, both hulls will be good alternatives (Falvey, 2004). Monohull was still considered the best choice when considering the relevant operational conditions. The speed will never exceed 5 knots, and the course keeping capabilities of the catamaran will therefore not reach its full potential. Refit flexibility was not included in the evaluation as it will not be relevant for this vessel. Speed loss due to sea state would be an important feature for the vessels ability to maintain its schedule. It was therefore given maximum weighting of 10. The monohull is likely to experience less speed alterations due to the sea state because of its large mass (Falvey, 2004). As the sources for this argument was not satisfactory, the two was considered equally good in this category. The calm water speed was also considered to be very important in this study as this will be the normal operating conditions for the ferry. Both vessels would operate well in calm water, but the monohull was considered slightly better than the catamaran due to it having steadier acceleration and heeling.

The safety aspect was considered irrelevant as there will be nothing in the operational area posing an abnormal risk to the ferry. It was assumed that it would need to comply with relevant rules and regulations to maintain the passengers' safety regardless of hull shape. The category "other attributes" was considered important because the aspects included will be important for the ferry's operation. Because the passengers' comfort and the operational capabilities were slightly more important it was given the maximum weighting of 9. Both the aesthetics and the machinery redundancy factor were given this same weighting. The aesthetics of the ferry may decide whether a passenger choose to use it. It was assumed that the two hulls of the catamaran would need to be wide to fit all the equipment in them. If too narrow, the space would be useless (Rudow, 2013). These wide hulls could make the catamaran look unappealing to the passengers. The monohull will likely need to have a high beam to ensure sufficient deck space. This may cause the design to look less appealing. As there were no reliable sources for these assumptions and no conclusions could be drawn on the final design's aesthetics, the two hulls were given the same neutral score. Machinery redundancy will in this study translate to battery room redundancy. The batteries need to be stored in two separate rooms to ensure a sufficient level of redundancy, should something go wrong. In the catamaran, the two rooms will likely be placed in separate hulls to ensure symmetry of the arrangement. The monohull will only separate the battery into two rooms and be more exposed to damage in both rooms in case of collision or similar. Therefore, the catamaran scored slightly better.

Once all solutions were evaluated the scores were summed up and compared to the maximum score possible, defined by the weighting of the criteria. This indicated that the monohull was the best solution with a score of 76.9% against the catamaran's 61.7%. It was therefore concluded to proceed with the monohull concept. The initial concept for the autonomous ferry was now set to be an autonomous monohull ferry using batteries as power supply.

### **6.3 Determination of Docking Approach**

For the further detail design, it was necessary to determine how the ferry is going to dock and how passengers will enter and exit. One option regarding the entry/exit of the ferry was to use the bow and stern of the vessel. The ferry would be designed identical in the

bow and stern. Passengers would be able to enter the ferry in one end and continue their journey out in the other end of the vessel without having to change direction. The other option is one single entrance at the side of the vessel. The two options are illustrated in figure 15. It illustrates how the passengers will move in and out of the ferry.

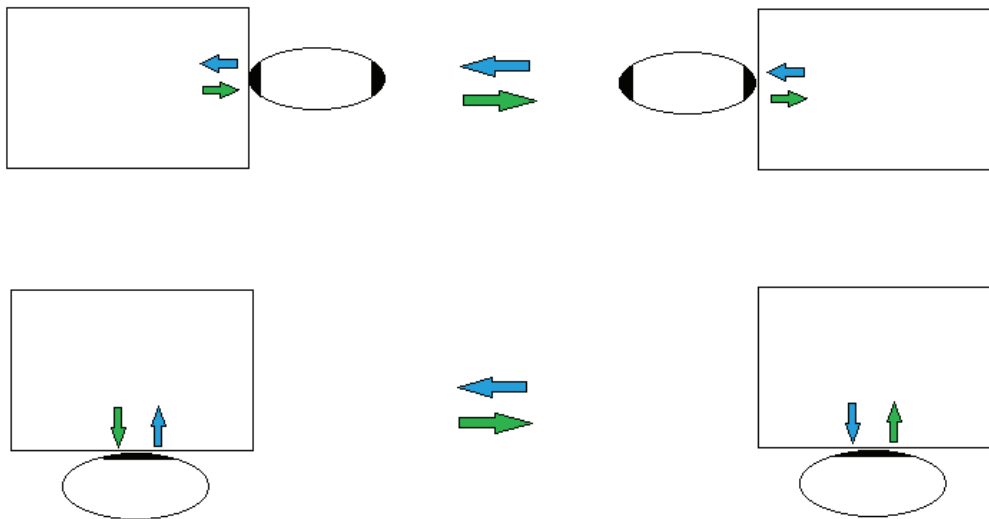

Figure 15: Possible solutions for how to dock the ferry

The weighted objectives method was applied to determine which entrance design to develop further in the detail design. This method is slightly different from the one applied to determine the hull shape. A detailed description of the method is found in section 3.2.1. The complete ranking performed in this section is found in table 13. The criteria used for the evaluation were cost, user friendliness, efficiency, safety and demand for space on board the ferry. Safety was considered the most important criterion and was thus weighted 30% of the total score. Cost, user friendliness and efficiency were considered equally important and weighted 20%. Cost was here, as in the case of the mooring solution, based on qualitative estimates and therefore not weighted heavier. Demand for space on board the ferry was considered the least important criterion and was weighted 10% of the total score.

Table 13: Ranking of alternatives on how to dock

|                    |        | Concepts           |       |                   |       |
|--------------------|--------|--------------------|-------|-------------------|-------|
|                    |        | 1 Docking in front |       | 2 Docking on side |       |
| Selection criteria | Weight | Rating             | Score | Rating            | Score |
| Cost               | 20 %   | 5                  | 1     | 7                 | 1.4   |
| User friendly      | 20 %   | 9                  | 1.8   | 7                 | 1.4   |
| Efficient          | 20 %   | 8                  | 1.6   | 7                 | 1.4   |
| Safety             | 30 %   | 9                  | 2.7   | 6                 | 1.8   |
| Demand for space   | 10 %   | 6                  | 0.6   | 9                 | 0.9   |
| Total Rank         |        |                    | 7.7   |                   | 6.9   |
| Rank               |        |                    | 1     |                   | 2     |
| Continue?          |        |                    | Yes   |                   | No    |

Docking on the side is considered the best option with regard to cost as the ferry would need only one entrance and mooring system for docking in this case. The other option require the installment of two entrances as one would be required in each end of the vessel. Considering user friendliness favours the option of one entrance in each end of the ferry. This because it enables the passenger to enter the ferry and continue straight ahead when exiting at the other side of the channel. With one exit at the side, the passenger would need to turn around and navigate more around the ferry. Wheelchair users would also get a more demanding transit with this option as they need to turn their chair 180 degrees before exiting the ferry. This is the basis for why the option of two entrances is favoured with regard to efficiency. The difference between the two options is smaller as it may be possible to make the single entrance in the side larger than at the two ends and thus increase the efficiency slightly. Considering the safety of the passengers, the two entrance option when docking with the front in is considered the best. If the ferry superstructure is closed, two exits would in provide better evacuation routes than one single door. Should there be possibilities of heavy rolling of the ferry, the two doors in each end of the vessel would also be less at risk for water intrusion into the ferry lounge. Still, the single door on the side performs better with respect to space demand for the ferry. This because less space is required from the channel if the vessel is placed with the side to the dock. This is seen from the illustration in figure 15. The results imply that docking with the front in would be the best option. The team therefore chose to move forwards with having one entrance in each end of the ferry.



## 6.4 Determination of Mooring System

Using vacuum to moor the ferry at dock was excluded as it is only available for vessels of larger size. It may become available for smaller vessels in the future but not within this study's timeframe (Gedde-Dahl, 2017). An adaption of the larger systems would imply excessive costs and thus is not an option. The remaining solutions considered included a lockable trapdoor, an automated hook, automated bollards and magnet mooring. Sketches of these alternatives can be seen in appendix C.4. An additional possibility would be to combine the existing alternatives, for example using a combination of the lockable trapdoor and magnet mooring. The solution using a lockable trapdoor is further referred to as a ramp, for simplicity. Project manager, Egil Eide, preferred the ramp solution and wished this to be part of the final design (Eide, 2017).

The ramp solution would consist of a ramp on board the ferry and a system on the dock adapted for this ramp. When the vessel is positioned at the dock, the ramp would be lowered and attached to the dock. It would hold the vessel in place while passengers move on and off. It would also have to be possible to leave the ramp in this open position over night when it is not in use. The automated hook or bollards would have to function in an analogous manner. The difference between this solution and the ramp is that it may not be necessary to use it during the day when the ferry is operating. Dynamic positioning would then be sufficient to hold the ferry in place at the dock for this brief time when passengers are moving on and off the ferry. This would be the case for the magnet mooring as well. If magnet mooring was to be used, it would be necessary to use a permanent magnet. This requires power supply only when the magnet is to be loosened from its grip. A non – permanent magnet would require constant power supply to keep the ferry in place. This would be less optimal as the mooring could fail in case of power shutdown. Based on this complete evaluation and recommendations from Egil Eide, the solution using a ramp was chosen.

As the ferry is the focus of this study, the ramp design was taken only to the concept stage. It will be necessary to perform a more detailed design study to determine the ramp design if it is to be used on the ferry that is built. As the ramp was intended for use as both the mooring and the entrance for passengers boarding the ferry, its design needs to be functional. In this study, the functional requirements for the ramp was set and

a concept design determined. Further analysis and developments would be necessary to be able to conclude that the design fulfills the requirements and will function properly. Three functional requirements were specifically relevant for this design:

- Be able to hold the ferry in place at the dock without constant need of power
- Be able to provide passengers a safe passage on and off the ferry
- Not harm passengers on board (during transit or docking)

An idea session was performed to reveal possible ramp designs that fulfills the requirements. Sketches of the concepts can be seen in figure 16. The first concept includes a ramp controlled by hydraulics being lowered into a bollard on the dock, see figure 16a. The bollard must be high enough so that the ramp will lie securely once in place. The second concept suggested was to use a ramp that would lock into a hole in the vessels bow area, see figure 16b. Another ramp would then be lowered from the ferry using hydraulics. This upper ramp would be pressed down using the hydraulics to securely keep everything in place. The dock would then have to be adapted so that movements from waves would be absorbed in a secure manner by both vessel and dock. The final alternative included a ramp on the dock that would fit into a hatch on the ferry bow. Another ramp would be lowered from the ferry and keep everything in place in an analogous manner to concept two, see figure 16c.

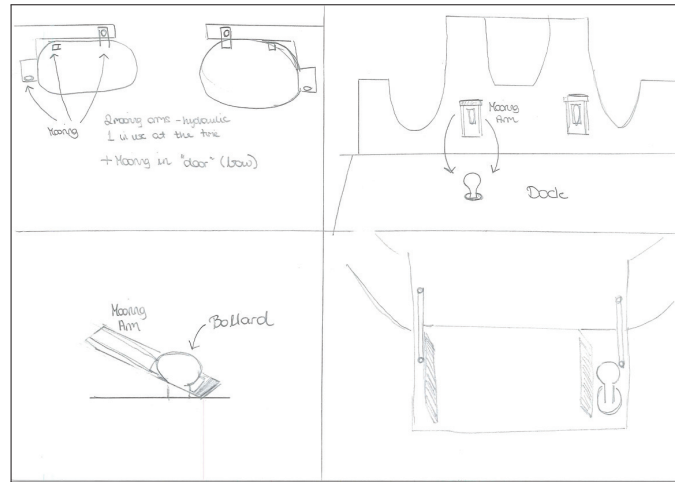

(a) Sketch of ramp concept number one

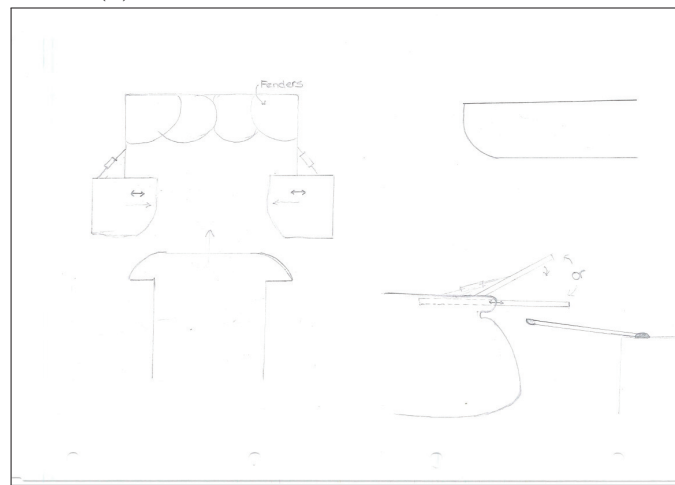

(b) Sketch of ramp concept number two

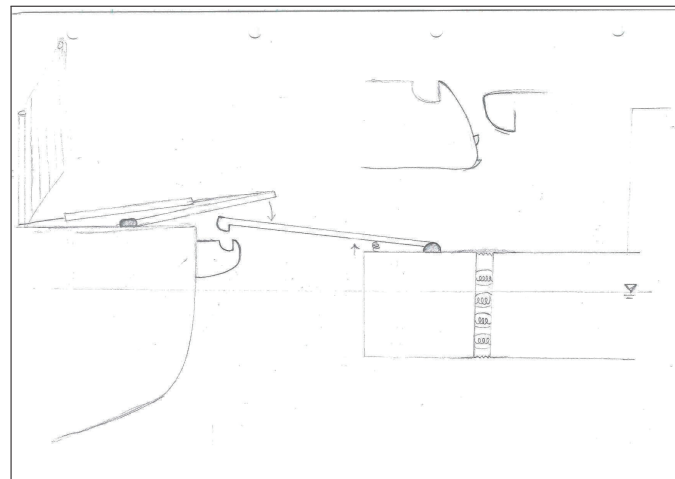

(c) Sketch of ramp concept number three

Figure 16: Sketches of possible ramp concepts for mooring

Concept one is a simple construction and would be easy to make. The disadvantage is that the ramp may need to lie unlocked on top of the bollard. If so, people could lift it of

during the night if the ferry is unsupervised. It may also have been problematic to find the correct height of the bollard that would make the system function optimally. If it were too low, the system would not be safe. If too high, the system may not function properly. The advantage of the second concept is that it would be able to hold the ferry steady in place, overnight as well, without using excessive power. Despite of this, it was considered a less optimal option. It would be challenging for the ferry to hit the ramp lock with the required precision if the weather was not perfect. The construction of concept three would be uncomplicated and parts would be easy to get hold of. It would also be easier to lock this ramp than for concept two. Because of this, concept three was considered the best option. The detail design of the ramp was not considered in this study as the ferry itself was the focus. Considerations were made throughout to ensure that the ferry design is tailored for the ramp. If the ferry is to be built in the future, the detail design of the ramp would have to be worked out. Only then would the ferry and ramp function optimally with the dock area and surroundings.

## 6.5 Safety Considerations

Once the initial concept for the ferry design was set, relevant safety requirements were considered. An emergency ladder was to be installed on the outside of the hull to secure that passengers are able to climb on board again if they should fall in the water. Bollards should also be installed on the vessel in case mooring by rope is necessary during maintenance or similar. As the vessel was to be as symmetric as possible, one ladder would be mounted on each side and end. It would be a permanent part of the hull, mounted onto the ship structure. In addition, a bollard for towing is to be installed on each bow. This is a requirement from the NBS and will not be included in the further design considerations even though it is part of the design. An alarm should sound when the mooring ramp is in motion. This to secure that none of the passengers are injured by the moving ramp or hydraulic equipment. The alarm could be subsequent beeping noises or a voice explaining that the ramp is in motion. Preliminary design was to use beeping noises as this was thought to be most effective regardless of the passenger group.

To maintain the passengers level of perceived safety as well as the actual safety, two emergency stop - buttons are to be installed on the ferry. One button was placed in

each end of the ferry, enabling all passengers to reach it quickly if needed. It is also important that the button is placed in the correct height so that both wheelchair users and children are able to reach it. Further, the button should be made similar to fire alarm triggers in public buildings, making it clear that it should not be used unless it is an emergency. When triggered, the emergency stop – button should stop the ferry’s movements and initiate contact with a supervisor stationed somewhere nearby on land. This person should be able to quickly contact the fire department, police or ambulance if necessary. Special agreements with the fire department should be made, securing short response time. If the emergency stop button is triggered, the ferry will hold its position after stopping by using the dynamic positioning (DP) system that will need to be part of the autonomous control system. If this system fail, an emergency anchor would have to be automatically deployed.

The communication between the supervisor and the ferry should be two -way like a telephone on speaker. The supervisor should have access to all surveillance footage from the ferry, and thus be able to see the passengers at all times. The surveillance will be done using cameras placed on the ferry and in the dock area. There should also be a separate communication system in place where passengers can press a button if they need to speak to the supervisor. This button could also be used if a fire was discovered on board and the passengers needed to alert the supervisor and fire department. A separate fire alarm button was considered, but dismissed as too many buttons would confuse the passengers.

In addition to this, a detailed emergency plan should be visible on the ferry, as well as on the dock. This should provide passengers with the necessary information on how to proceed in case of an emergency. It should inform them how to put on their life jacket in case of evacuation and about the location of the life jackets and fire extinguishers. It should also inform them of when to press the emergency stop button or the button for contact with the supervisor. The emergency plan will not be modeled in detail in this study, but should be made using *The Regulation on Life-saving Appliances on Ships* as recommended by the Norwegian Maritime Authority.

The dock should limit the access to the ferry to ensure that no more than twelve passengers are aboard the ferry each round trip. The allowed weight on board the vessel is also limited by the design load. The passage through this registration could possibly be used as a point

of confirmation that the passengers are familiar with the safety information. This will be further investigated when the dock layout is determined. It was initially set to be 24 life jackets on board the ferry. Twelve of which were adult life jackets and twelve for children.

The choice of propulsion will affect the navigational capabilities of the vessel and thus affect its safety. Azimuth pods were chosen for propulsion. The difference between these and podded propulsion is that the electrical engine used to turn the pod is located inside the hull. In podded propulsion, this engine is placed directly on the pod outside the hull. This makes dry docking necessary to perform maintenance on the engine, meaning downtime for the ferry. The advantage of using podded propulsion is that the connection through hull is simpler to construct as only wires are pulled through. Using azimuth pods, this connection needs to be secure and water tight. As these pods are common in today's industry and make inspection and maintenance less complicated, they were still the natural choice and will be used for the ferry in the study. Further, the power supply for the ferry was set to be batteries. It will therefore be important that the ferry operation stops if the battery level is too low. This is one of the many important safety features that the autonomous system needs to control. In case of low battery level, the ferry operation should temporarily stop while the batteries are charged to a certain level.

The risk assessment recommended limiting the flammable material on board the vessel. This was taken into consideration when determining the building material. It was decided that the ferry will be made from aluminium. Fiberglass was considered due to its low weight and price, but discarded as it is highly flammable and therefore not suited. Steel was discarded due to its high weight. Aluminium has a range of properties depending on its compositions. It has a melting point of 660 degrees Celsius, but is not flammable. If the temperature exceeds the limit, the aluminium will melt but not burn. Due to its good thermal conductivity, the heat will dissipate more quickly through the material than with other materials. This avoids hot spots and possibly avoid the aluminium melting (Vargel, 2004). Careful considerations regarding the other materials used on board could help prevent fire on board the vessel. This should be accounted for when designing the vessel outfitting.

In its pure form, aluminium will not have sufficient strength but several hundred different alloys are available, many with complex qualities. It can resist the progressive oxidization

that cause steel to rust until ruined. When exposed to oxygen, the aluminium surface forms an inert aluminium oxide film that protects the surface. This will not begin to flake as rust does on steel, and therefore prevent further oxidization. The properties making it most attractive is its low price, light weight, fabricability, physical properties, mechanical properties and corrosion resistance (Davis et al., 1993). Aluminium has approximately one third the density of steel. With the correct treatment, it can still be nearly as strong as stainless steel (Davis et al., 1993). The alloy series most commonly used for marine purposes is the 5xxx series. It is highly resistant to corrosion, even in salty environments. Different methods may be applied to shape the aluminium as desired. There will be limitations to what can be accomplished regarding shape. This is something the design team must account for. In this study, the material will not be further investigated. Choice of the correct alloy was thus postponed to the further work.

## 6.6 Autonomy Considerations

When designing an autonomous vehicle, there are many factors to considered. The physical vessel has to interact with the autonomous system, passengers and the surroundings. The design also needs to comply with rules and regulations, something that can be challenging as no specific regulations for autonomy exist. The vessel also has to be able to communicate with land.

The autonomous vessel in this study fits into Lloyd's Register's autonomy level number 4. The topics discussed here are therefore related to vessels with the same autonomy level. Vessels in level 4 are fully autonomous, with a human on the loop. This implies that the vessel has to manoeuvre itself and all systems has to function on their own. However, a person on land will supervise and take control of the system if necessary, but the autonomous system has to make all main decisions. This requires interaction between the autonomous control system and all other ship systems. A good example of this is the fire system. On manned vessels, the initiating of the fire extinguishing system is manually controlled. On the autonomous vessel, this has to be done by the autonomous control system. Another example is the interaction with the batteries on board. The batteries will have constant surveillance and on a manned vessel, the crew can monitor the state of the batteries at all times. If there is an indication that something is wrong in the system,

the crew can shut it down. On the autonomous vessel, this decision has to be made autonomously. If the system chooses do not respond correctly and do not shut down the system, the batteries might overheat.

The autonomous system also have to manoeuvre the vessel itself. To do this, a collection of different sensors have to feed the system the information it needs, replacing the captain. These sensors have to be able to see hindrances and obstacles in order to manoeuvre the vessel safely from one dock to the other. The design of the vessel therefore has to facilitate the sensors so that they can function in the best possible way. An example of this is Velodynes' LIDAR, Puck Lite (Velodyne Lidar, 2017), that measures the distance to an object by illuminating the object with a laser light. This LIDAR has a 100 m range, a 360° field of view horizontally and a 15° field of view vertically in both directions. This Velodyne LIDAR has to be placed so that its field of vision is not disturbed by the vessel itself, or the passengers on board the vessel. It should also be shielded from tampering and sabotage by inquisitive passengers. To avoid this, the LIDAR should be placed high and out of reach. Figure 17 shows two possible placements of the sensor. Placing it at the middle of the vessel as shown in figure 17a is not functional as passengers get in the field of view of the LIDAR. Placing it farther toward the bow and aft as in figure 17b removes this problem, but will increase the blind zone in front of the vessel. If necessary, the sensor could be placed on the bow and aft part of the hull itself, but this would leave them open to tampering. With a vessel that has passenger entrances in the bow and aft, the sensors would have to be placed to the side, which would create a blind zone at port or starboard side. An alternative could then be using four sensors placed in the bow and aft area. The best sensor configuration will depend on the vessel at which they are to be placed.



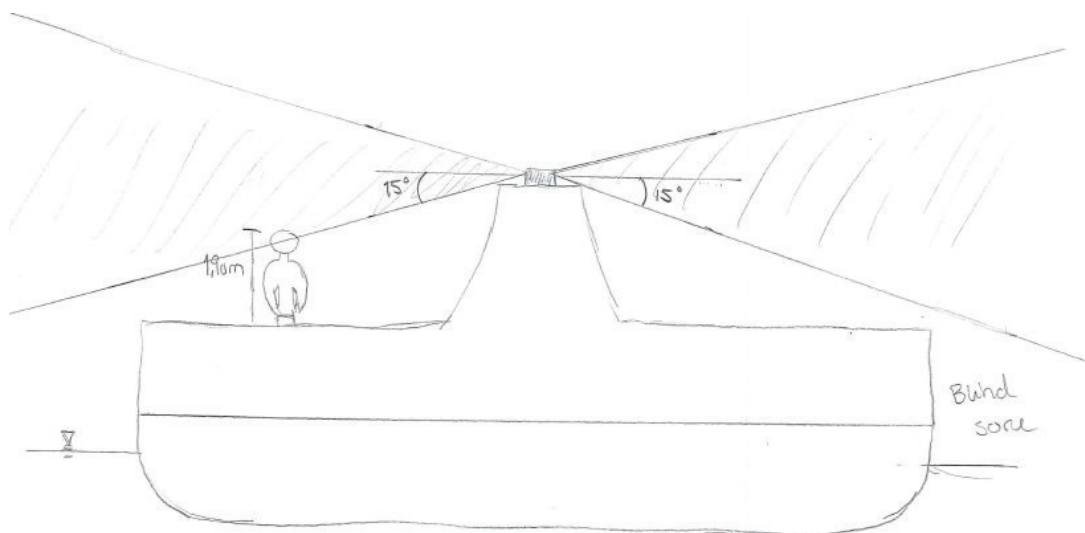

(a) Sensor placed high at middle of vessel

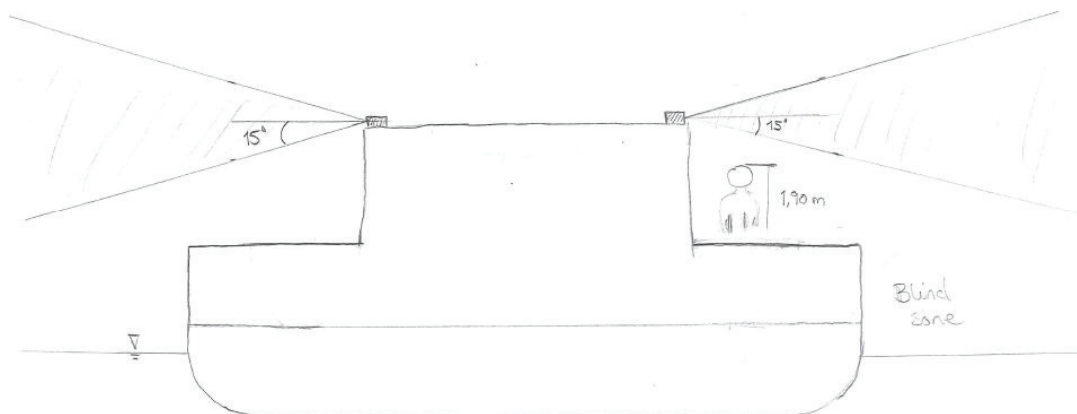

(b) Two sensors placed high closer to the ends

Figure 17: Possible locations for sensor on a ferry roof

It may be wise to shape the hull so that the vessel is easy to manoeuvre. This limits the complexity of the autonomous system, by avoiding the need for extra propulsion systems for docking and precision manoeuvring. What hull shape is better depends on the operation and operational area of the vessel. In this study it would be beneficial to use a hull that gives some degree of directional stability, while also being easily manoeuvred into the dock. In the operational area, there are currents that will hit the vessel from the side, and a hull shape that manoeuvres well through the currents would be advantageous. Further, the vessel is to operate in an area with various challenges, like rough weather conditions, currents and traffic from other vessels. The autonomous vessel is to be designed

so that it will stop when there is hindrance in its path. However, it would not be practical with many unplanned stops, as this is uncomfortable for passengers and a waste of time. For the operation to be as smooth as possible, there needs to be cooperation between the autonomous vessel and other trafficking vessels. Navigation lights can be used on the vessel to indicate that it is autonomous. There could also be signs in the operational area to warn trafficking vessels. An agreement or regulation has to be made on how the traffic should handle the autonomous vessel. For other vessels operating in scheduled service, the autonomous vessel could be programmed to let them pass at given time intervals. This would imply a temporary short stop in operation. Under harsh weather conditions the vessel has to evaluate whether or not to operate. It could be wise to set a limit for what conditions are feasible to operate in. The vessel could at certain wind speeds be out of service, to avoid accidents. The autonomous system therefore must receive the necessary data to make a decision. As a backup, a human who surveys the vessel could stop operation.

The autonomous vessel also has to interact with the dock, and the docking system. As the vessel has no crew, the docking also has to happen autonomously. This might include a separate autonomous system on land, and the two have to function together in unison. The system on the dock and the system on the vessel have to communicate, so that the docking can be carried out correctly. When the vessel is docking, it has to get into the right position for the docking system to fasten it to the dock. The vessel therefore has to signal to the dock system when it is in position. An alternative is to have a docking system that is mechanical, and only depends on the vessel to maneuver into the mechanism to fasten. This could be some form of hook that fastens to the vessel when it drives into it. This mechanism needs to ensure the charging of the batteries as this is also needs to be done autonomously. The specific solution for charging the vessel is not considered in this study. It is assumed that the solution will be easily implemented into the mooring solution.

As a passenger ferry, the autonomous vessel is interacting with humans in its operation. It is important that the passengers perceive the vessel to be as safe and comfortable to use as a regular passenger ferry. In the project thesis, preceding the master thesis, a market survey was performed. The result of this survey showed that 23% of the people who answered are uncomfortable with using an autonomous vessel, and 34.6% may be

uncomfortable with it (Havdal et al., 2016). This indicates that many are uncertain about this kind of concept, and passenger comfort and safety will be important features of the design.

For the vessel to feel safe and comfortable for the passengers, factors like speed, acceleration and deceleration is of importance. Fast acceleration or deceleration could feel uncomfortable for passengers, in particular to those who are standing up. Avoiding too many quick stops and starts is therefore important. The autonomous system has to be designed so that unnecessary stops are avoided. The sensors should therefore be able to separate between a trafficking vessel and a smaller object that is not a hindrance, like a bird that flies in front of the sensor. At the same time, the sensors should be able to detect for example a human in the water and know to stop. Too high speeds might also feel uncomfortable when there is no captain to control the vessel.

The vessel should also be perceived as safe when passengers see it. Equipment like life jackets, fire extinguishers, possibility to contact help and life buoys can make the vessel feel safer. Clear marking of escape routes is another way to make the vessel feel safer. The structure in itself can also look and feel safe. A vessel that is stable when passengers move around is important. Fencing and handholds can also make the vessel feel, and look safer to the passengers.

The factor that makes most people uncomfortable with autonomous vessels is the fact that there is no crew on board (Havdal et al., 2016). To compensate for this, the passengers should have the opportunity to communicate with a land base. If something was to happen on board the vessel, a responsible person on land should be notified and be able to communicate with the passengers to help and reassure them. The passengers can also be given the opportunity to interact with the vessel to hinder an accident by the means of an emergency stop button.

Another side to having passengers on the vessel but no crew, is that different human behaviour has to be taken into account. Passengers could constitute a danger to themselves by tampering with the vessel systems, climbing on the structure or getting into altercations with each other. People might be curious about the different sensors and antennas placed on the vessel. To avoid tampering or sabotage of the systems, they should be designed and placed to be unavailable. This can be done by covering them, or by placing

them out of reach. The superstructure of the vessel should account for people trying to climb on it. It should be avoided that passengers fall into the water, as they then rely on others to see it happening and helping them out of the water.

## 6.7 Design of Dock Layout

The next step was to design the dock where the ferry would take on its passengers. The dock needs to be adapted for the ramp mooring and be functional for passengers using the ferry. It also needs to function with the gangway and elevator system that would be used to enter it. The concept for the gangway system was investigated in the preceding project thesis and is illustrated in appendix C.5 (Havdal et al., 2016). It will be a necessity that the number of passengers entering the ferry is limited autonomously at the dock. The ferry is designed for a maximum of twelve passengers. If more passengers than this enter, the ferry cannot disembark. If the predetermined weight limit is exceeded, the ferry must remain in the dock. A system limiting the number of passengers and monitoring the weight on board, was therefore also a required part of the dock design. The maximum allowed weight will be the same as the design load. In addition, heating in the dock floor was required, as determined in section 5.3.3. This to reduce the risk of passengers slipping and hurting themselves on the dock.

The necessary decisions that needed to be made for the dock concept included the location of the two docks, the layout of the docks and what systems to use for passenger- and weight registration. It was decided in the preceding project thesis that the ferry would use a separate dock. An already existing dock used by the ferry to Munkholmen was considered but rejected as it would make the logistics on the dock troublesome. If people gathered on the dock waiting to use the ferry to Munkholmen, people wanting to use the autonomous ferry may believe that the queue is long even though no one is waiting for that ferry. This may cause passengers to not use the ferry as they believe it would be time consuming to wait in queue. It would also be impractical for the passengers if the docks get crowded. In summertime, a fishing vessel also make use of this dock to sell fish. Three vessels using the same dock with people moving on and off could be problematic as the dock is quite small. The docks for the autonomous ferry were therefore to be placed at the same location as the potential bridge in the area (Hjerteplanen, 2017). These dock

locations are illustrated in figure 18. It was apparent from this sketch that Trondheim Coastal Association would need to move one of their piers to make place for the dock at Fosenkaia. As they are renting this space from the municipality, it should be no problem getting this in order if the municipality wish to use the autonomous ferry instead of a bridge in the area.



Figure 18: Illustration of the placement of the docks at Ravnkloa and Fosenkaia

The layout of the docks was determined through an idea and sketching session. The suggestions were discussed in the design team to shape the final concept suggestion. In addition, a group of students participating in the course Experts in Teamwork (EiT) studied this same dock concept design problem. The report resulting from their study was used for inspiration and input in this study. Sketches of the suggestions to dock layout is seen in figure 19. The layout suggested by the EiT team is seen in figure 20. The complete EiT report can be found in the attached folder containing pdf versions of relevant references as it is not publicly available.

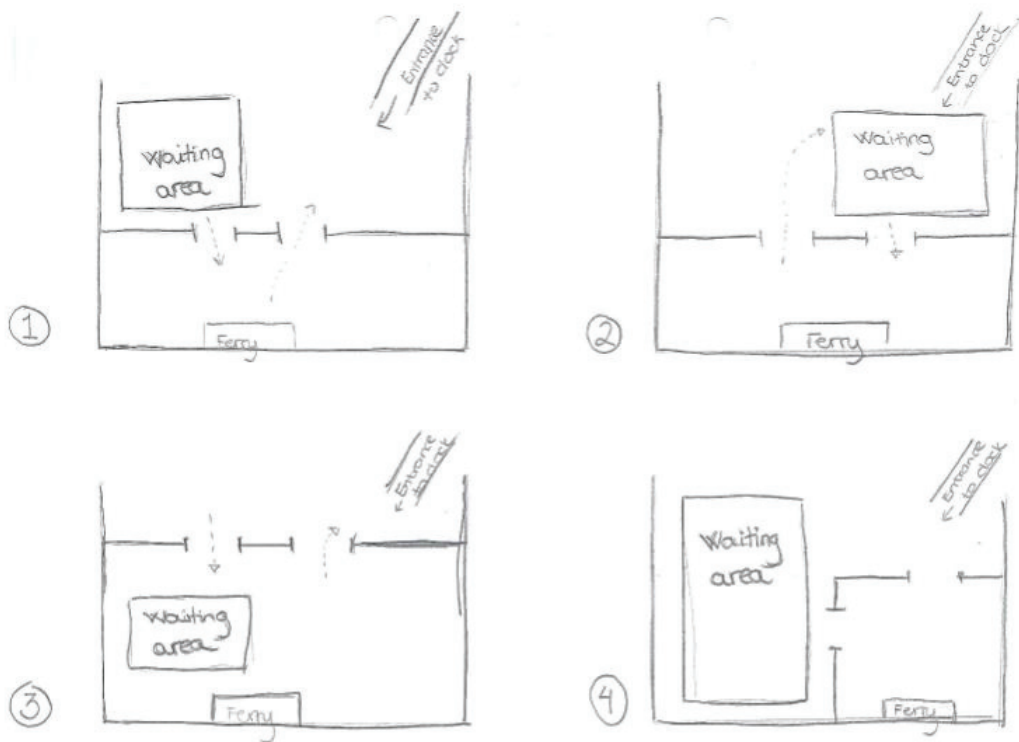

Figure 19: Possible dock layout concepts

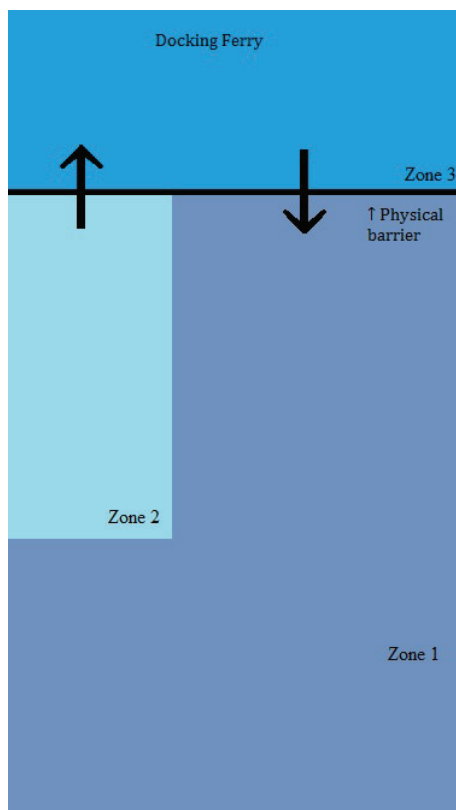

Figure 20: Possible dock layout as suggested by the EiT team (Engebakken et al., 2017)

The separation of the ferry and dock area was to be set up in such a way that the passengers can wait on the dock until the ferry is safely in the dock. Only then can the passengers go through the registration gates. This to secure the passengers safety by avoiding crushing hazards from the hydraulic ramp. The EiT layout included this feature. The flaw of their design was that the passengers would enter the ferry to the left of the dock. This is an unnatural flow as things in Norway normally are right focused. For instance, entrance to an escalator is normally on the right side. When waiting on the escalator, it is also common to stand to your right to enable others to pass on your left. The ferry entrance was thus to be on the passengers right hand side when standing on the dock. The other flaw in the EiT design was that the zone separation gave the passengers waiting to board less space on the dock than the ones disembarking the ferry. Passengers waiting to use the ferry need extra space to dwell on the dock. Those exiting the ferry only need space to move across the dock and onto the gangway as they will leave the dock immediately. Thus, the zone for passengers waiting was decided to be larger than that for passengers exiting the ferry. Based on these decisions, concept number two and three in figure 19 was eliminated. It was further decided that the dock were to be shaped according to the ferry so that it could dock into this space. The dock would also be shaped with a pier on one side of the vessel to support it when lying still at the dock. This will take some of the load of the mooring ramp as it helps reduce the moment caused by the current.

As the space inside the registration barrier was to be considered as unused space on the dock, concept number four was the best alternative. This concept enables the passengers to utilize the maximum of the dock space as only the required area is limited for the ferry entrance. Wheelchair users would need to turn their chair to board the ferry. It will therefore be a requirement to have sufficient space inside the registration area for them to turn, 150 cm turning diameter (Sintef Byggforsk, 2006). It was also concluded that a fence will surround the dock to ensure passengers safety. A ladder and a life buoy was placed on the dock. This ladder was designed to go all the way over the fence. Passengers who fall into the water will then have a direct route to get out of the water. It was also suggested to have benches in the waiting area on the dock to increase passengers comfort while waiting for the ferry.

To ensure that the passengers using the ferry are aware of essential safety information, they will need to confirm reading it before entering the ferry. As no personnel will be present at the dock, the registration system was decided to take care of this. When entering the ferry through the registration gates, the passenger must press a button to confirm the disclaimer of liability and that they are familiar with the safety information. The information is to be given on an information poster at the dock, with possibility of getting it in audio by pressing a button by the poster. An illustration of the complete concept is found in figure 21. A rough estimate of the space demand on the dock, set the dock size to be 7 metres long and 7 metres wide out into the channel. Measurements of the area in Google Maps (Google Inc, 2017) were used to understand how this would look in the channel. Appendix C.6 show how much space was available in the relevant areas. The size and placement of the docks would need further verification after detail design is performed. This will not be considered in this study.

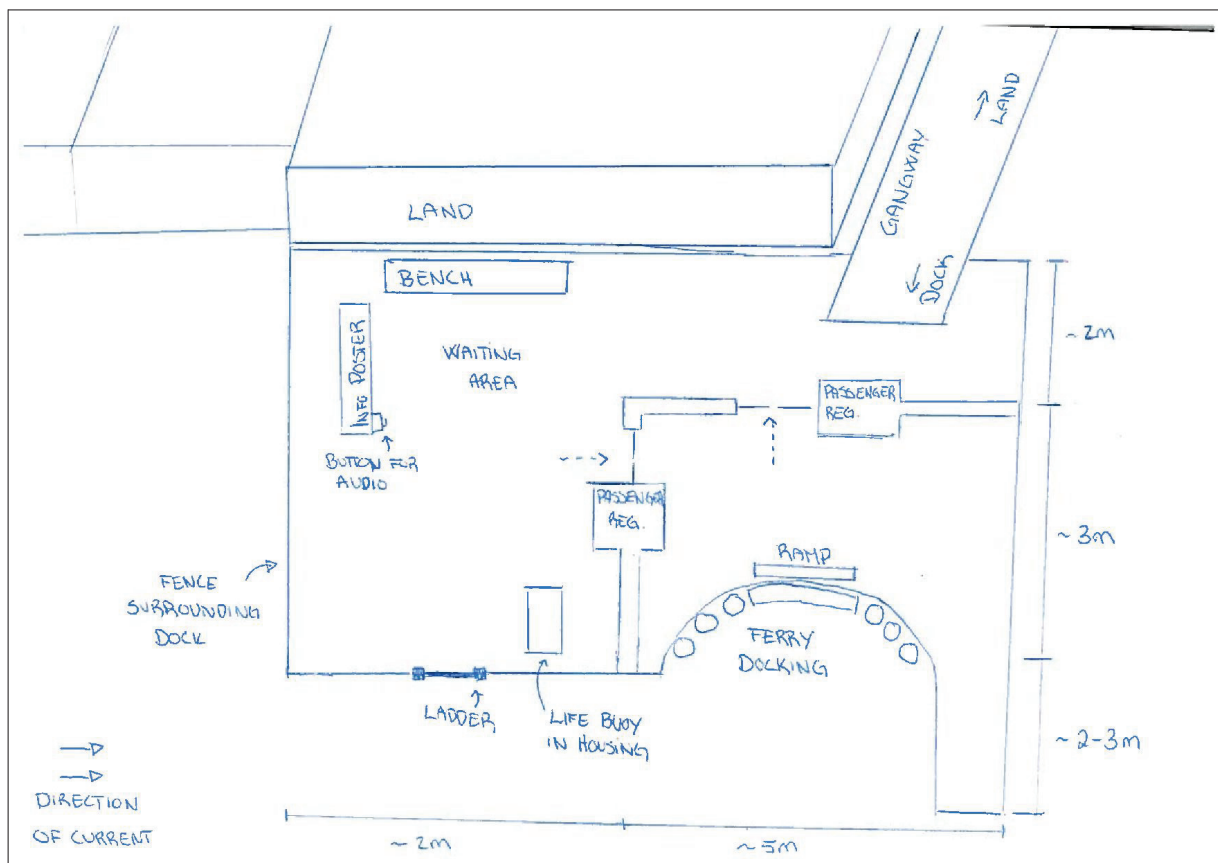

Figure 21: Illustration of final dock layout concept



The technical equipment needed to offer the desired functionality at the dock is described in the EiT report (Engebakken et al., 2017). Despite the EiT study concluding differently with respect to dock layout, the technical investigations were useful for this study. Relevant failure modes and risks related to the system was discussed, as well as what technical equipment is needed. As this study did not go into detail on this dock concept, preliminary technical decisions and cost estimates were based on this EiT study. The primary registration system was suggested delivered by Fujica. The estimated cost was NOK 25 000 per gate. The secondary registration system suggested on board would imply a cost of NOK 40 000 plus a monthly cost of NOK 700. In addition, costs related to the building and fitting of the dock itself would accrue (Engebakken et al., 2017). To limit the weight on board the vessel, a sensor would be mounted to keep watch over the vessels draught. This will alert the autonomous system if the draught is too high and the ferry would not disembark until the weight on board is reduced.

As with the ramp, this dock design was restricted to concept design only. A more thorough design study would be necessary if the dock system is to function optimally with the ferry. It was still necessary to determine the desired concept in that the ferry design could be adapted for this solution. If not decided until after the ferry design was set, excessive costs could accrue if substantial changes to the ferry were necessary to implement the dock design.

## 6.8 Estimation of the Required Area on Main Deck

A room-lab was executed to investigate the necessary area of the passenger lounge. This exercise was made up of two parts. First, the arrangement of the passenger lounge was tested in life size. This part of the exercise was mainly used to determine the suitable space for each passenger group. It also provided insight for the team as to how the room might feel for the passengers. This is challenging to experience from a model size drawing. Finally, different passenger combinations were tested in model scale to test if certain combinations would be infeasible or feasible.

### 6.8.1 Life-Size Experiment

Initial space requirement for each type of passenger was determined using Sintef Building and Infrastructure and various non-scientific sources online (Sintef Byggforsk, 2005),(Sintef Byggforsk, 2015),(Sintef Byggforsk, 2006). A space of 4 x 6 metres was marked up using tape. This was considered a probable deck area on the ferry. It was likely that the actual passenger lounge area needed to be changed at a later stage in the study. Six meter straight midship would imply a very square – shaped vessel, with only one meter for the bow area given that the vessel is 8 metres long.

Different loading conditions were tested by marking the required area for each passenger and vehicle on board. Chairs were used to give volume to the different spaces. This gave better indication of the actual space limitations. The loading conditions tested are presented in table 14.

| Loading Cond. Id | Decision              | Description of Load Case               |
|------------------|-----------------------|--|
| A                | Space per person      | One chair with person                  |
| B                | Space per person      | Two chairs with two persons            |
| C                | Feeling of space      | 12 seats incl. people arranged in room |
| D                | Feeling of space      | 11 seats incl people and wheelchair    |
| E                | Number of wheelchairs | 5 Wheelchairs and 7 seats incl people  |
| F                | Space per bicycle     | Two bicycles incl people               |
| G                | Bicycle arrangement   | 12 bicycles orthogonal to wall         |
| H                | Bicycle arrangement   | 4 bicycles diagonally to wall          |

Table 14: Description of loading conditions - Life size testing

Sintef Building and Infrastructure defines the shoulder breadth of a person as 63 centimetres. It also defines the required space for a seat including leg space to be 100 cm. A reasonable estimate for seat spacing would be 70 cm. Loading condition A was the live size verification of this area. Loading condition A in figure 22a shows how a person was seated normally within 100 cm. Loading condition B was tested to verify that 70 cm is sufficient when people are sitting close to each other. Figure 22b clearly illustrates that the two passengers have enough space to be comfortable. This would also be the case if the passengers were more broadly shouldered.

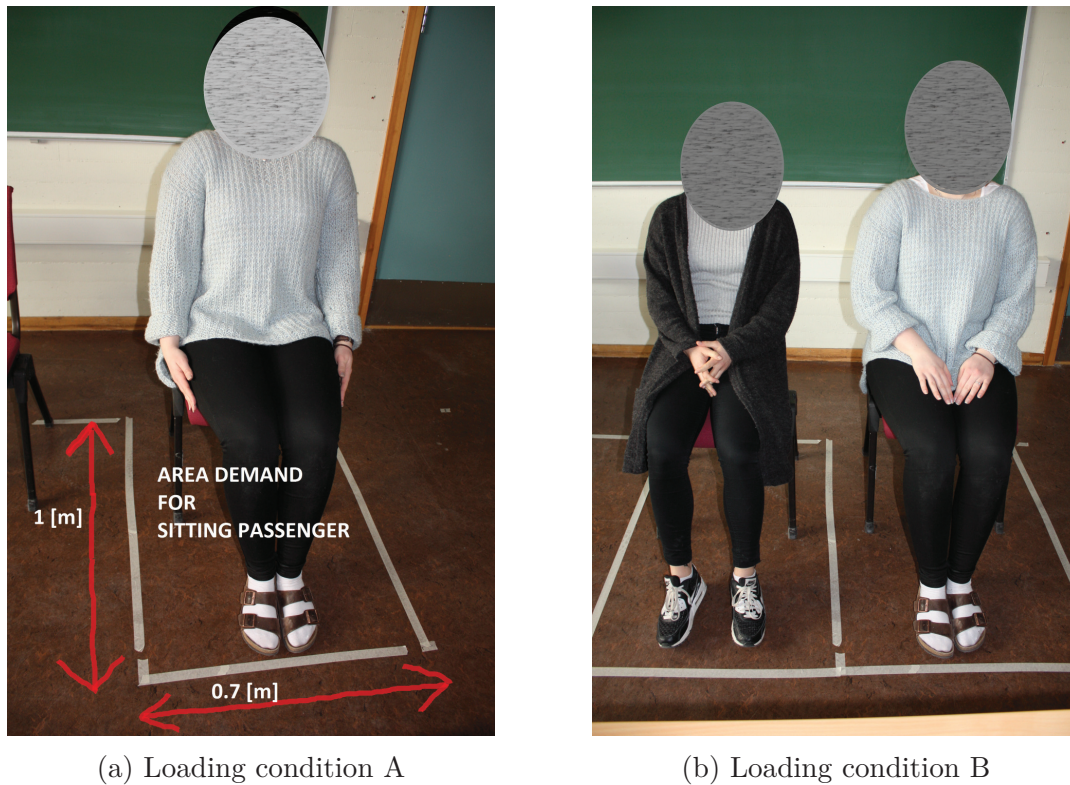

Figure 22: Loading condition A and B in life-size testing

To get a better sense of the room if the ferry were filled with regular passengers, twelve seats were marked in the room. Chairs were used to get a better feeling of the passengers' presence in the seats. The room was arranged with six seats on each side as this is the simplest design. The arrangement is illustrated in figure 23. It will also provide good functionality as it makes it easy for wheelchairs and strollers to move through the room. The seats do not take up much of the space in the room. Both in the middle of the room and along the wall there was unused space. The seat will take up 4.2 metres on each side of the vessel. It is likely that the straight mid ship will be shorter than six metres on the final design. Thus, not taking up the entire space was considered positive. The unused space in the middle of the room is two metres in breadth. It is ideal for people in wheelchairs or with strollers. Entering and exiting the ferry without having to turn their chair or stroller is possible as they may stand in the middle of the ferry for the transit.



(a) Loading condition C - Six seats



(b) Loading condition C - Twelve seats

Figure 23: Loading condition C in life-size testing

Two loading conditions including wheelchairs on board were tested to determine how practical the abovementioned design would be. Loading condition D and E includes one and five wheelchairs on the ferry, respectively. Illustrations can be found in figure 24a and 24b. As seen from the pictures, one wheelchair on board in addition to the eleven persons seated does not cause problems. There is space between the seats and the wheelchair for people to move. The situation became less optimal when five wheelchairs were introduced. Figure 24b illustrates how the wheelchairs take up space in the room. It is clear from the picture that passengers will be unable to move freely inside the ferry when five wheelchairs are on board. The person in figure 24b is just able to move in between the wheelchairs and the people seated. On the opposite side of the room there is no space for passage. This may cause dangerous situations if an evacuation was necessary. Thus, the required space is not sufficient to secure the passengers safety. It was based on this test concluded that a maximum of three wheelchairs could board the ferry simultaneously. Had there been fewer other passengers on board, there would be more room to move about as the empty seats take up less space. As the wheelchairs have significantly higher weight than the other passenger groups, the limitation of three wheelchairs was reasonable with respect

to weight as well. The trim will be considered during the stability calculations to verify that this restriction will maintain the passengers' safety. It may be relevant to inform passengers before boarding the ferry that wheelchairs will need to stand in the middle of the ferry to secure optimal stability. This may be included in the safety information given to all passengers before using the ferry. There was no need for weight restriction on strollers. Normally, people do not seek to feel cramped and the number will limit itself. This is commonly seen in elevators. Many are approved for up to thirteen people, but are seldom loaded with more than eight people as it feels cramped.

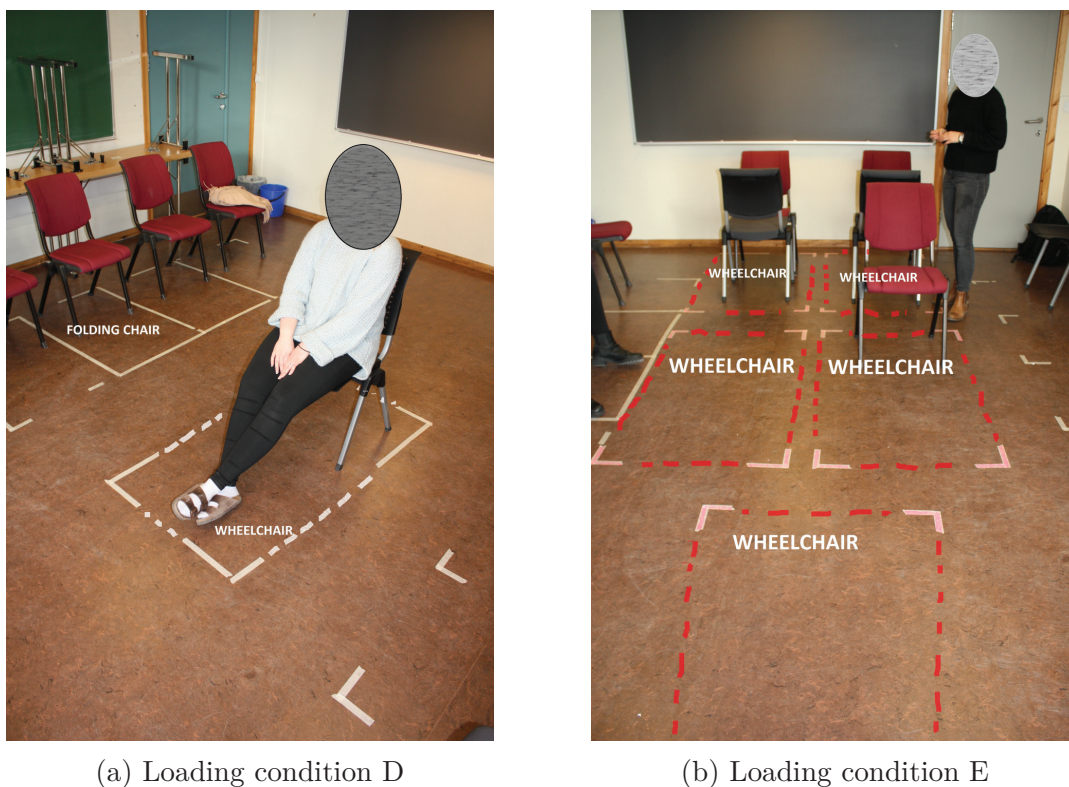

Figure 24: Loading condition D and E in life-size testing

The required area for bicycles on board was set using measurements of life size bicycles. Figure 25a shows two bicycles next to each other in a bicycle rack. The distance between the two slots is 70 cm. In total, the two bicycles were 140 cm wide. It was the handlebars that determined the width as they were the broadest part of the bicycles. The length was 170 cm. Information from Sintef Building and Infrastructure confirms these notations as reasonable (Sintef Byggforsk, 2015). The size of a bicycle was thus set as 0.7 x 1.8 metres. Further, two people were placed next to the bicycles to determine the actual required space. As figure 25b displays, it is at the end of the row that the width increases due to

the owner standing next to the bicycle. In the middle of the ferry, people may stand in between theirs and their neighbour's bicycle, not taking up any extra space. The width required for two bicycles including people was set as 180 cm. This is a 40 cm increase from the bicycles alone. The live size testing verifies this assumption. It was thus assumed an increase of 40 cm at each end of a bicycle line up. This information was useful to verify the length of the passenger lounge. Twelve bicycles including the passengers would take up 4.6 m ( $= 0.7 \cdot 6 + 0.4 \text{ m}$ ) on each side of the vessel.

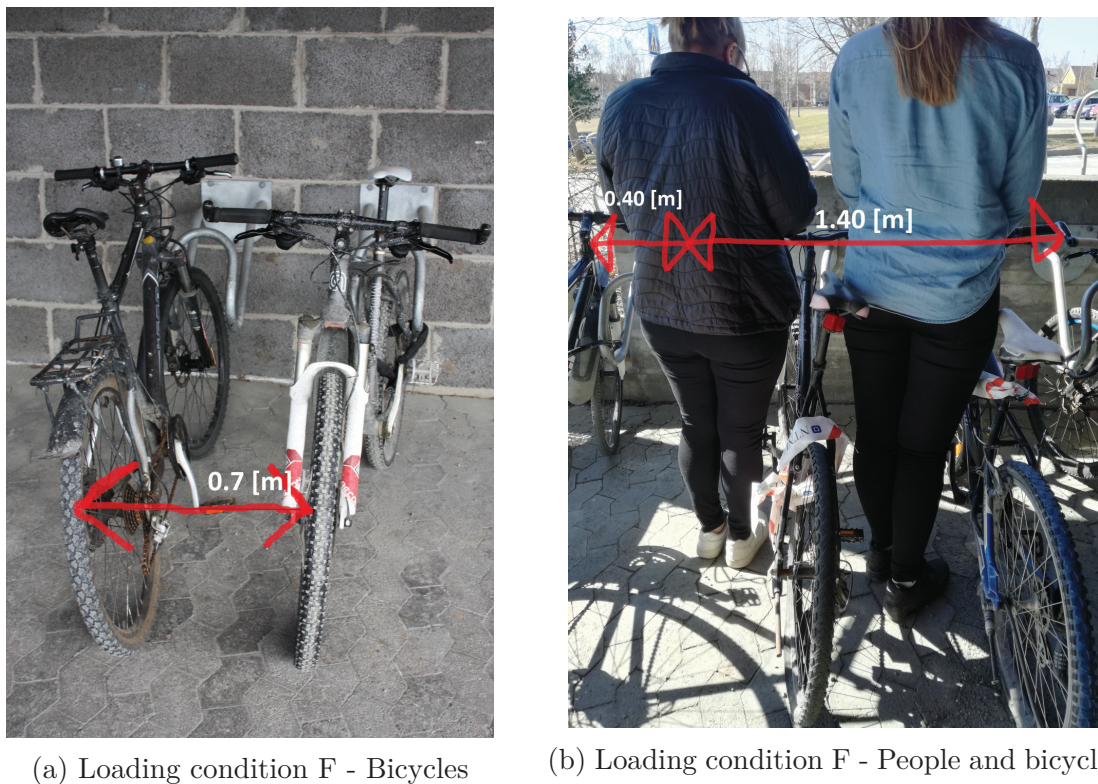

Figure 25: Loading condition F in life-size testing

The next step was to determine the best arrangement of the bicycles on board. Figure 26a illustrates the scenario where twelve bicycles are arranged with their wheel orthogonally to the wall, six on each side of the room. Chairs are placed inside the areas to give a better representation of the space between the two rows. As seen from the figure, there is not sufficient space between the rows for people to move freely. Thus, this was considered a less optimal solution. The passage was here 30 cm wide. Four bicycles were then placed on an angle in the room to test if this obtained better access in the middle. An illustration of this arrangement is found in figure 27. The bicycles are marked in red. The passage from loading condition G was marked between them as seen in the figure 26b. The new

passage was marked in red. It is obvious that this is a more functional solution as the passage here was 60 cm wide. This is double the width in loading condition G. It is clear from figure 26b that a person can pass between the rows. Loading condition H was therefore considered a possible solution. If used, it will be necessary that the bicycle rack can turn or be modelled to fit both ways. The ferry does not turn for the return trip. The arranging of bicycles would be troublesome for passengers if the rack is faced the opposite way of their embarking. It would also be possible for the passengers to stand holding their bicycle. The need for a bicycle rack would disappear, yet it would increase the risk of a chaotic loading of the ferry. If the bicycle rack were to be implemented in the design, the seats would need to be foldable. If not, there would be less space for the bicycles in general. In addition, foldable seats will secure the seats against rain as water will not gather on the seat when not in use. It was therefore decided to use foldable seats on the ferry.

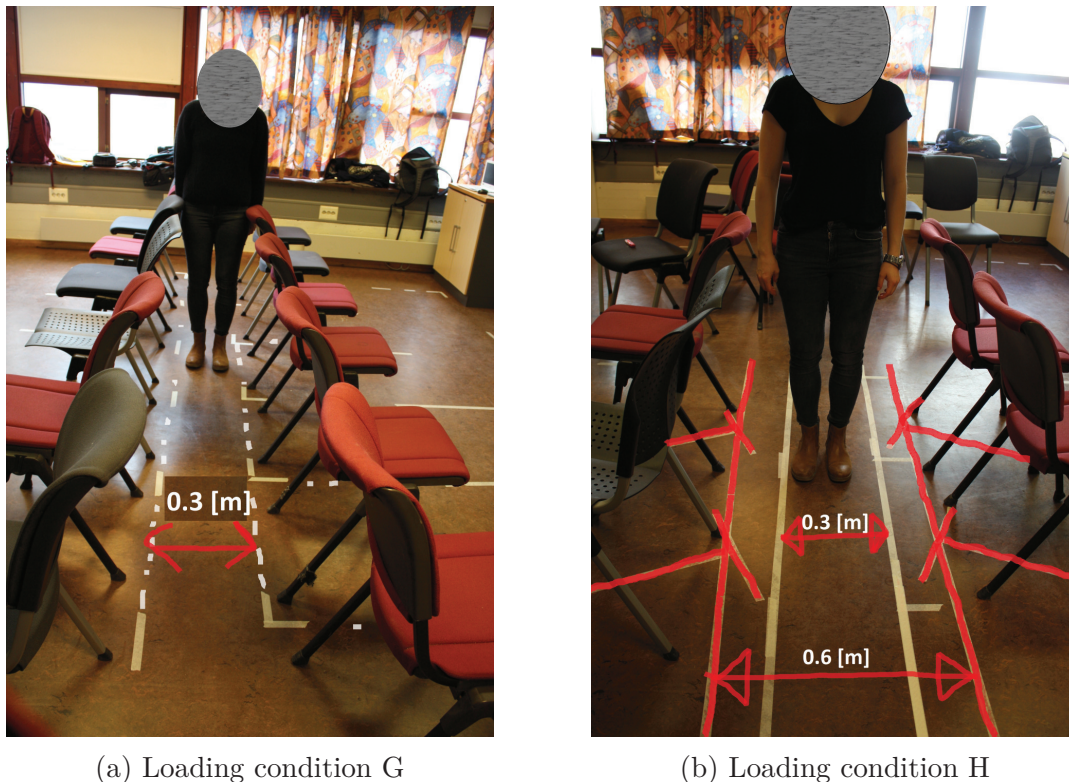

Figure 26: Loading condition G and H in life-size testing

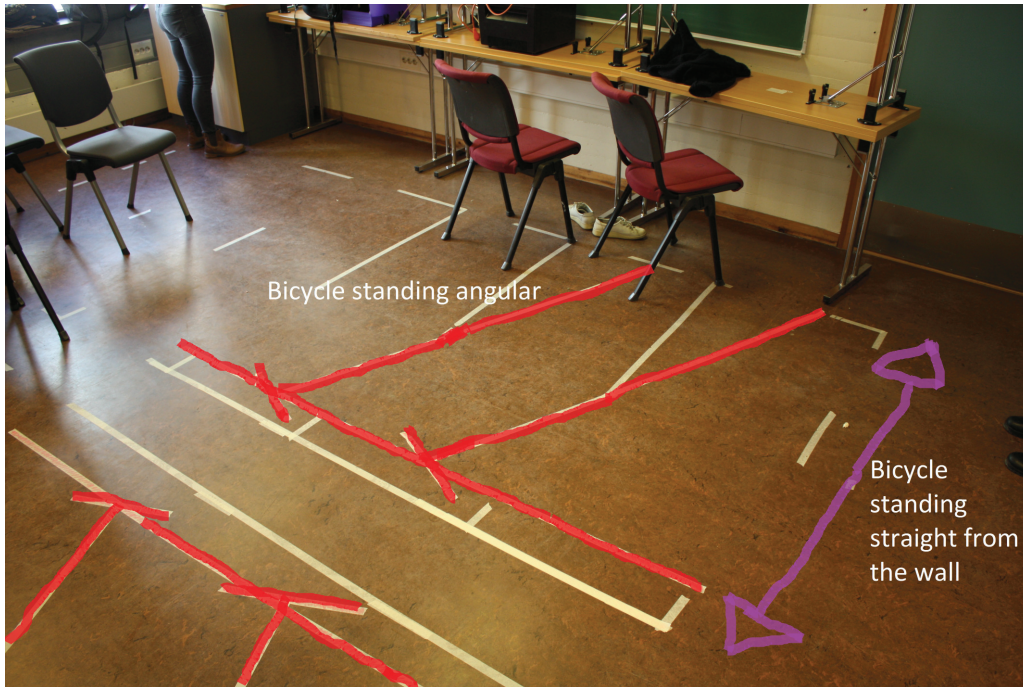

Figure 27: Loading condition H in life-size testing

### 6.8.2 Model-Size Experiment

The goal of the exercise was to determine the appropriate dimensions of the passenger lounge and how the passengers should be organized. As there would be infinitely many possible loading conditions, it was impossible to test for all. The conditions considered most relevant and likely, were therefore in focus. Following this, the main dimensions of the vessel were to be estimated. Six centimetres on the model equals one meter life size. Three different vessel models were made in scale. The most relevant one was 8 x 4 metres, the two others were equivalents of 8 x 3.5 m and 10 x 3.5 m. The midship of the eight- and ten metre long vessels, are six and eight metres, respectively. Loading conditions investigated in this section are presented in table 15. They were here identified using numbers instead of letters for easier distinction between life size and model testings. The loading conditions are further referred to as scenarios for better readability. It should be noted that the wheelchairs and strollers include the person in them.

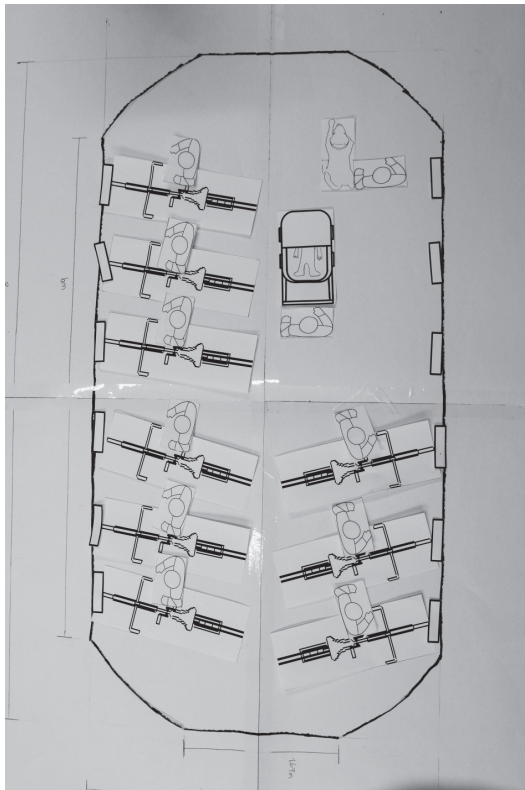

Table 15: Loading conditions presented as scenarios - Model size testing

| Scenario Id | Bicycle | Stroller | Wheelchair | Dog | People | Vessel size |
|-------------|---------|----------|------------|-----|--------|-------------|
| 1           | 9       | 1        | 0          | 1   | 11     | 8 x 4 m     |
| 2           | 6       | 1        | 0          | 2   | 11     | 8 x 4 m     |
| 3           | 8       | 1        | 0          | 1   | 11     | 8 x 4 m     |
| 4           | 6       | 1        | 0          | 1   | 11     | 8 x 4 m     |
| 5           | 1       | 1        | 5          | 0   | 6      | 8 x 4 m     |
| 6           | 3       | 2        | 0          | 1   | 10     | 8 x 4 m     |
| 7           | 3       | 2        | 0          | 1   | 10     | 8 x 4 m     |
| 8           | 3       | 1        | 2          | 0   | 9      | 8 x 4 m     |
| 9           | 0       | 0        | 0          | 0   | 12     | 8 x 4 m     |
| 10          | 0       | 0        | 0          | 0   | 12     | 8 x 4 m     |
| 11          | 4       | 0        | 1          | 0   | 11     | 8 x 4 m     |
| 12          | 4       | 0        | 1          | 0   | 11     | 8 x 4 m     |
| 13          | 4       | 0        | 1          | 0   | 11     | 8 x 4 m     |
| 14          | 2       | 0        | 0          | 0   | 0      | 8 x 3.5 m   |
| 15          | 4       | 0        | 0          | 0   | 0      | 8 x 3.5 m   |
| 16          | 12      | 0        | 0          | 0   | 0      | 8 x 3.5 m   |
| 17          | 10      | 0        | 0          | 0   | 4      | 8 x 3.5 m   |
| 18          | 9       | 0        | 0          | 0   | 9      | 8 x 3.5 m   |
| 19          | 0       | 0        | 0          | 0   | 12     | 8 x 3.5 m   |
| 20          | 0       | 0        | 0          | 0   | 12     | 8 x 3.5 m   |
| 21          | 0       | 0        | 0          | 0   | 12     | 8 x 3.5 m   |
| 22          | 0       | 0        | 1          | 0   | 11     | 8 x 3.5 m   |
| 23          | 0       | 0        | 1          | 0   | 11     | 8 x 3.5 m   |
| 24          | 0       | 0        | 1          | 0   | 11     | 8 x 3.5 m   |
| 25          | 12      | 0        | 0          | 0   | 12     | 10 x 3.5 m  |

### Scenarios for the 8 x 4 metres Vessel

Scenario 1 illustrates that there is sufficient room on board even when bicycles dominate the area on the ferry, see figure 28a. The passage between the bicycles is 60 cm and was assumed to be sufficient for evacuation. This is a decision that needs to be validated by the Norwegian Maritime Authority in order to get approval for the design. Scenario 2 and 3 shows a similar result, see figure 28b and 28c. In scenario 2, the other end of the ferry has a lot of unused space. This will give the passengers the feeling of comfort. Had the passengers boarded the ferry in a more random pattern the space would be less efficiently used. The ferry could then have been more cramped than in these scenarios. Scenario 4 illustrates the minimum required space for the passengers in scenario 2. This is illustrated in figure 28d. It is evident that the ferry could possibly be smaller but that the passengers' comfort would be compromised.



(a) Scenario 1

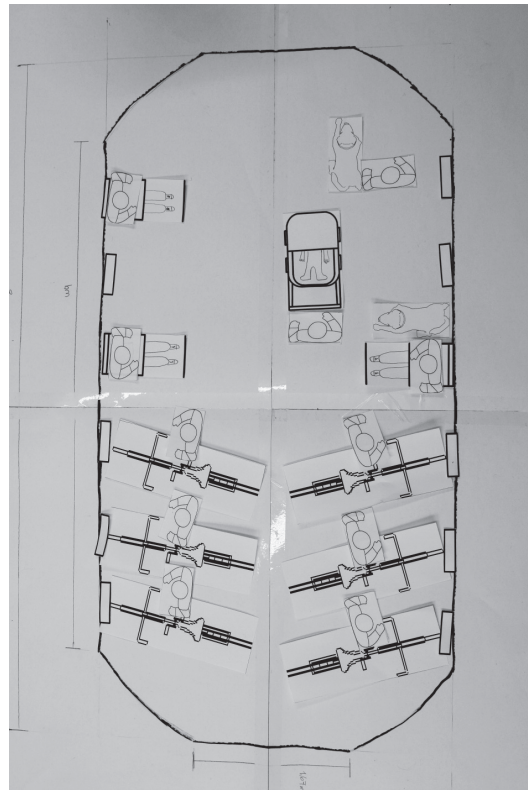

(b) Scenario 2

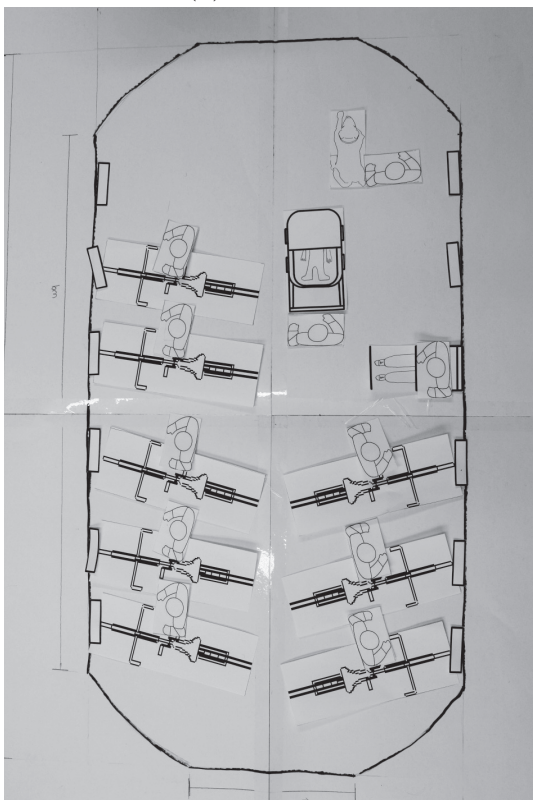

(c) Scenario 3

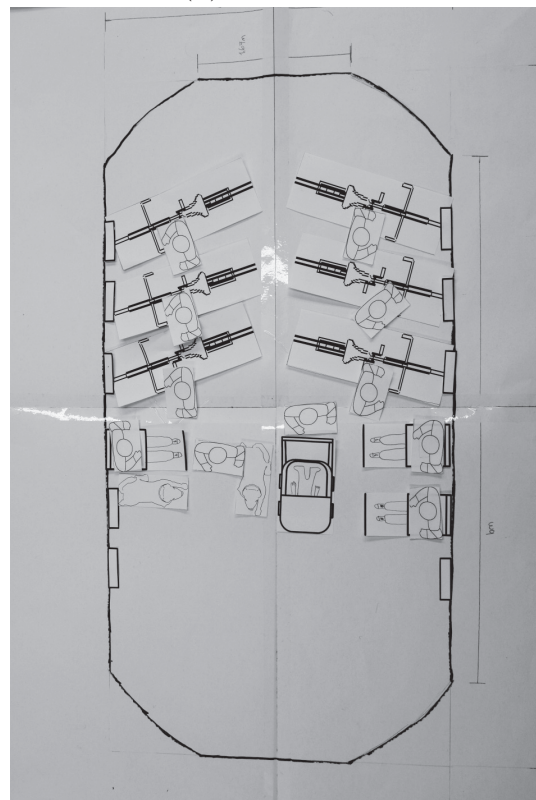

(d) Scenario 4

Figure 28: Model testing scenarios 1,2,3 and 4

Scenario 5 made it apparent that the wheelchairs need assigned places on board, see figure 29a. If all wheelchairs on board are placed on one side, the vessel will experience trim. It is likely that wheelchair users would naturally stand in the aisle at the centre of the ferry. In this case, the trim should not be a problem. It may be beneficial to inform passengers of this problem pre-boarding. It will therefore be considered a part of the mandatory safety information. This will ensure that all passengers are aware of the effect of large weights on board. Further, Scenario 6 and 8 illustrates how the ferry can handle a mixture of passenger types. Scenario 7 is an illustration of how little area the passengers may require if comfort is less important. The illustrations are found in figure 29b, 29d and 29c, respectively. The bicycles were placed orthogonally to the wall in these scenarios. It is apparent, as in the life-size testing, that this is an infeasible option.

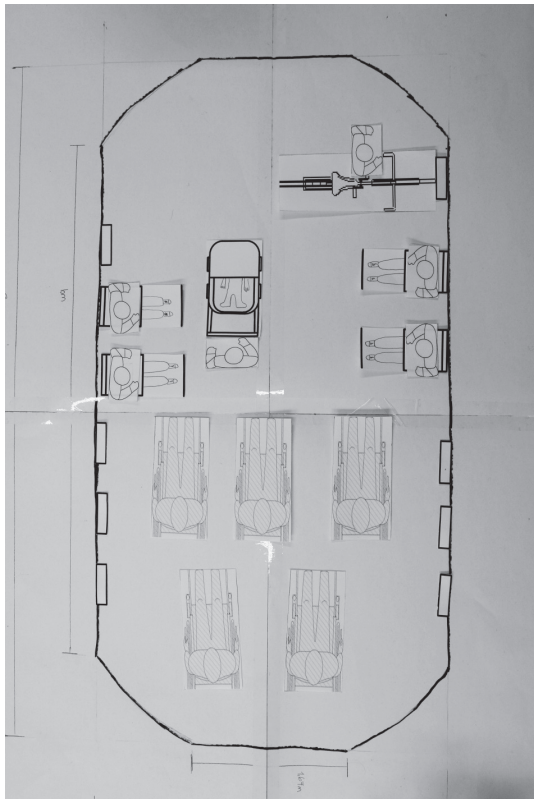

(a) Scenario 5

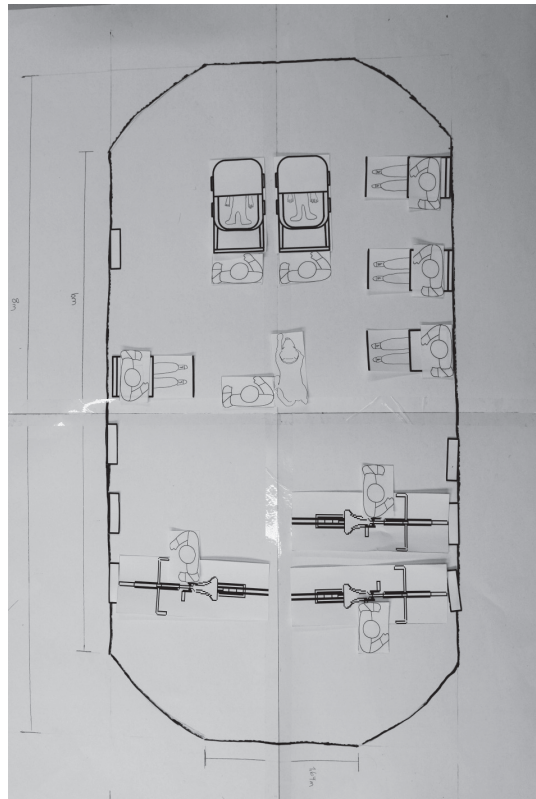

(b) Scenario 6

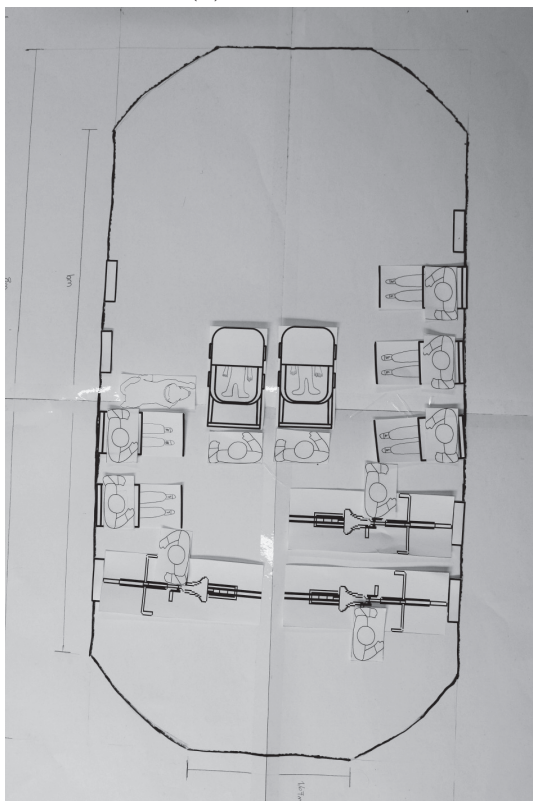

(c) Scenario 7

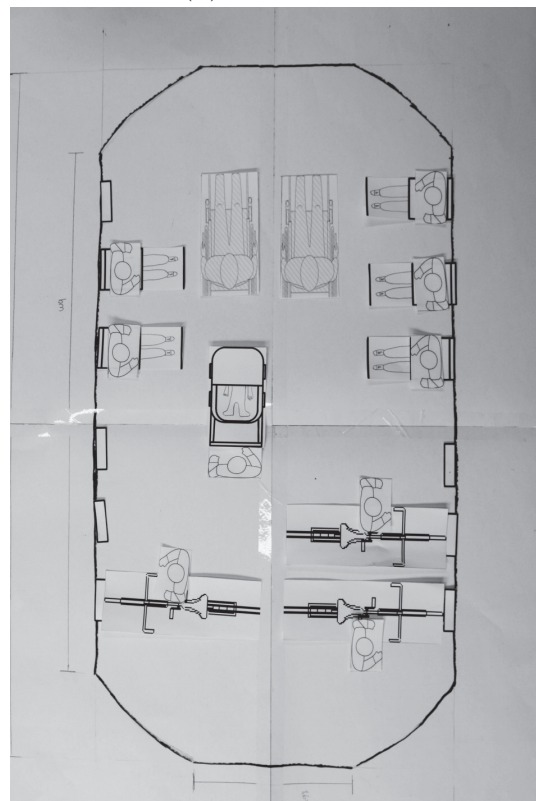

(d) Scenario 8

Figure 29: Model testing scenarios 5,6,7 and 8

Even though scenario 9 was tested in the life-size test, it was reconsidered here. As seen in scenario 9 in figure 30a, there is unused space both in the longitudinal and transverse direction. The seats have more space between them than assumed necessary in the life-size test. Scenario 10 have the seats placed slightly too closer together, see figure 30b. In reality the six seats on one side require 4.2 metres. This is thus the required length of the parallel midship. As passengers normally would not organize themselves as orderly as in the subsequent scenarios, it seemed relevant to investigate a more random arrangement. Scenario 11, 12 and 13 illustrates how the ferry may be used, see figure 31a, 31b and 31c. The space is less optimally utilized. The wheelchair user may feel blocked and cramped, especially in scenario 11. This illustrates why it is important to have more than the minimum required space on board.

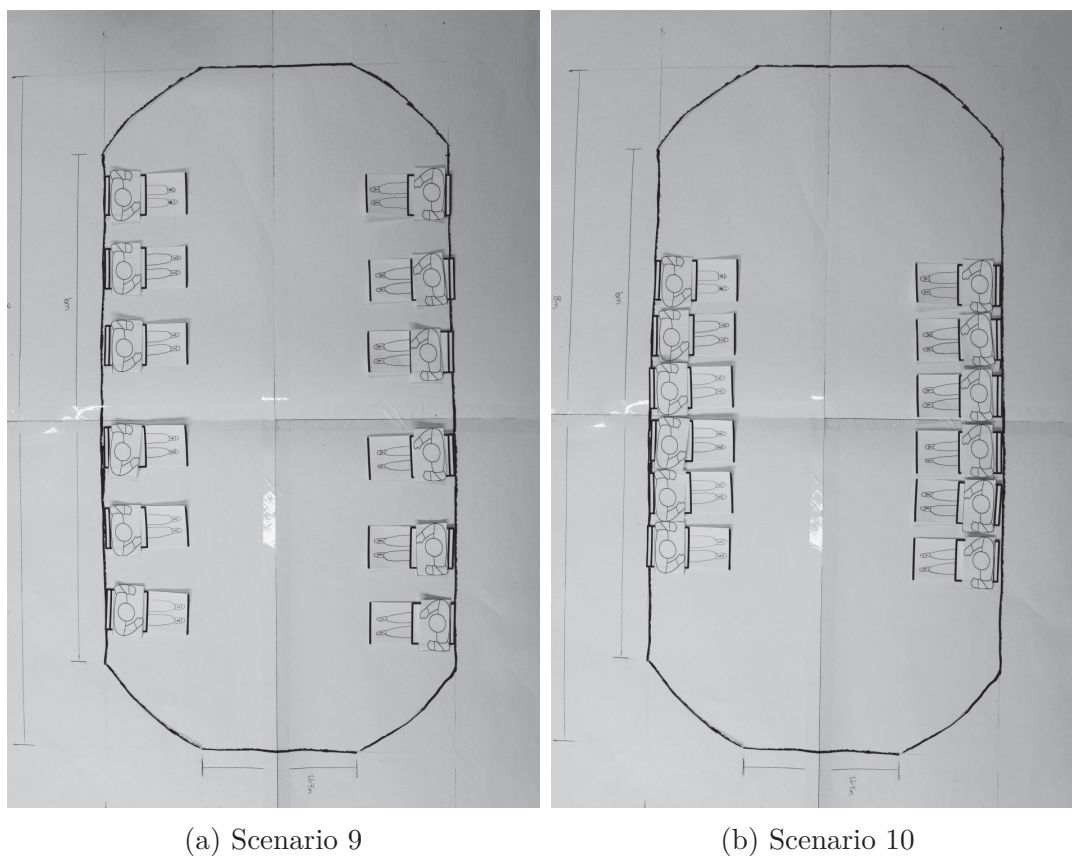
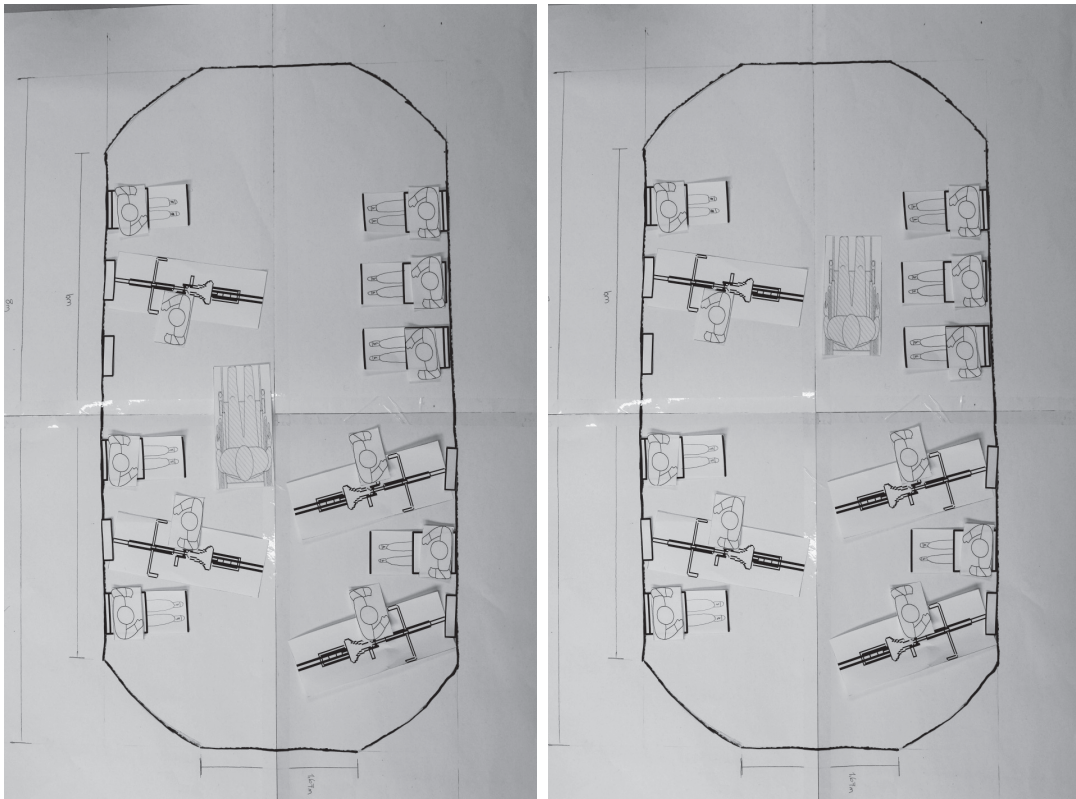
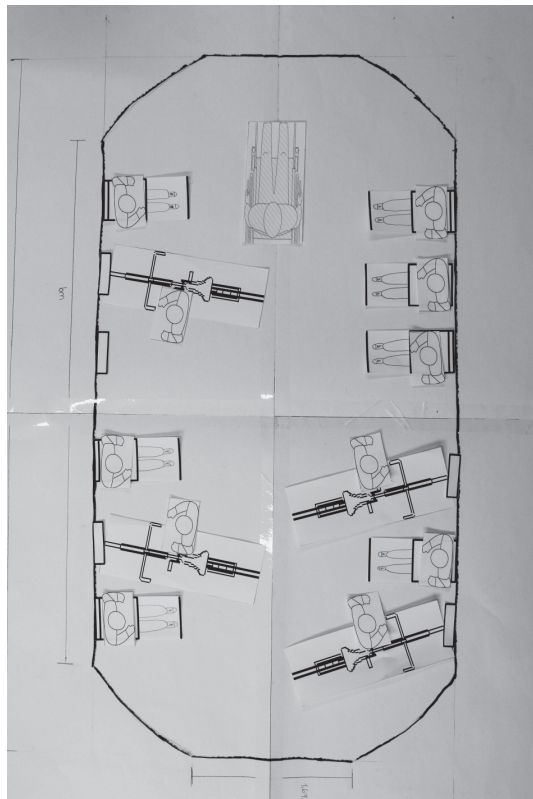

Figure 30: Model testing scenarios 9 and 10



(a) Scenario 11

(b) Scenario 12



(c) Scenario 13

Figure 31: Model testing scenarios 11,12 and 13

### Scenarios for the 8 x 3.5 metres Vessel

The following scenarios illustrate a vessel of 8 x 3.5 m. The focus was set on the bicycles and wheelchairs. In scenario 14, two bicycles are placed orthogonally to the wall. Illustration is found in figure 32a. As in the case of the broader vessel, there was not enough room to move between the bicycles. In this case, there was no room at all. Scenario 15 was used to test if the bicycles could be placed at an angle, see figure 32b. Here as well, there was not enough room for free passage. Scenario 16 and 17 illustrate that there is not room for twelve bicycles on board. The illustrations are found in figure 33a and 33b. There was not enough space for four rows of three, or three rows of four bicycles. For the vessel of this size, the valid scenario was number 18, which illustrates how nine bicycles would fit on the ferry. This includes the passengers accompanying the bicycles. See figure 33c. No seats would be available for the passengers in this scenario.

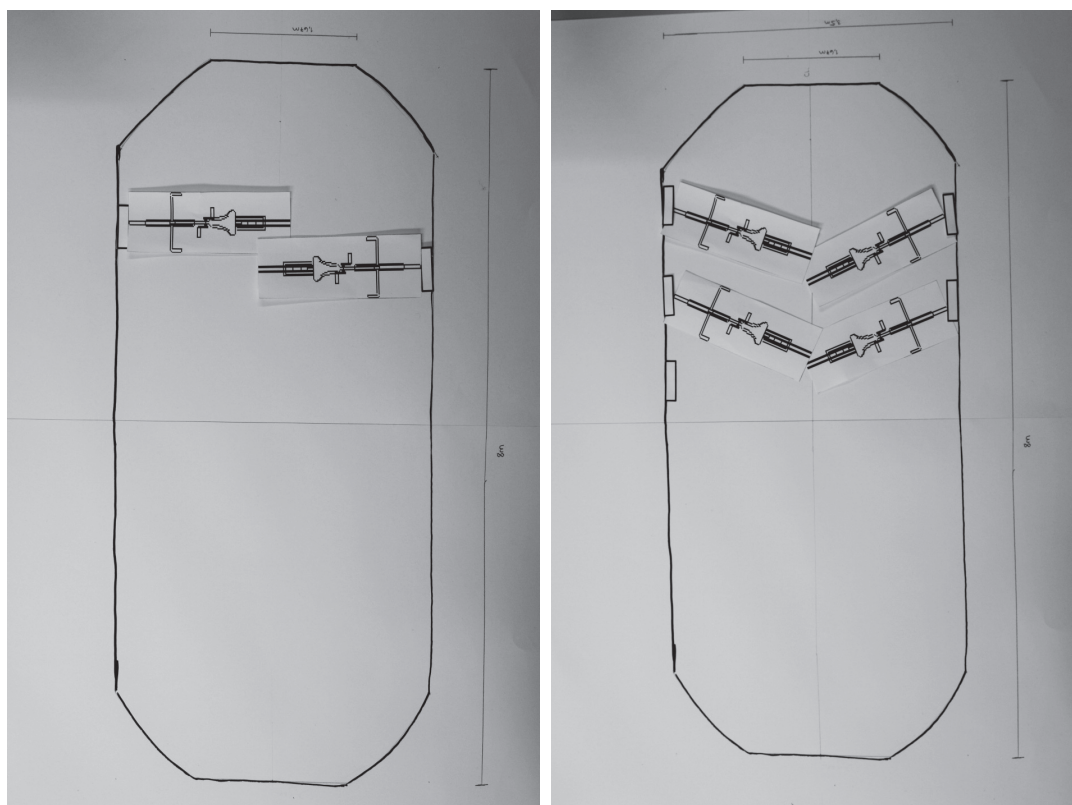

(a) Scenario 14

(b) Scenario 15

Figure 32: Model testing scenarios 14 and 15

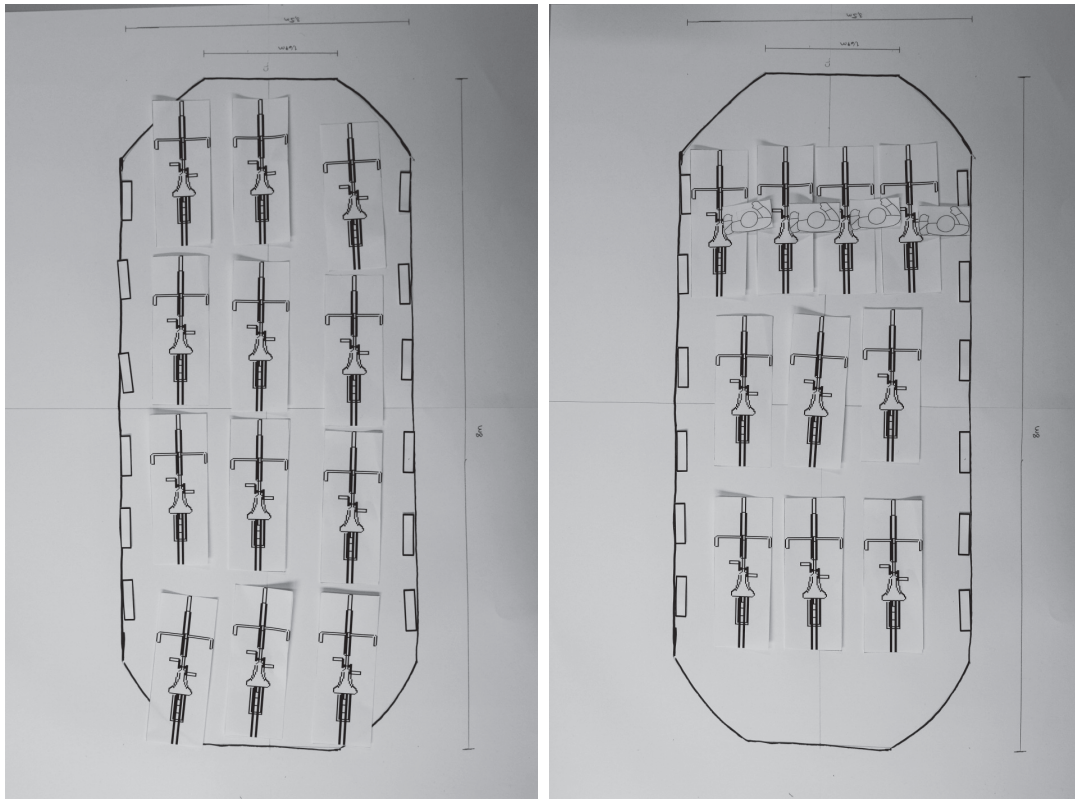

(a) Scenario 16

(b) Scenario 17

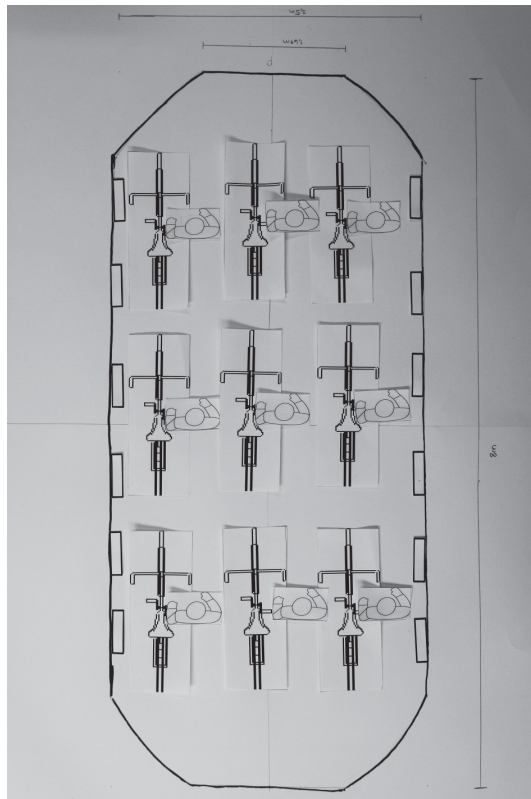

(c) Scenario 18

Figure 33: Model testing scenarios 16, 17 and 18



Scenario 19 illustrates that twelve passengers would be comfortable on a ferry of this size as well, see figure 34a. Scenario 20 - 24 looked at alternative ways of organizing the seats on board. They could possibly provide a better experience for the passengers. In scenario 20 (figure 34b) the room is well organized with space for wheelchairs and others. The downside of this concept is that less bicycles would fit in the room. A restriction of six bicycles would likely be needed. The same is relevant for scenario 21, see figure 35a. In addition, the wheelchair would have to turn to move through the ferry. The route becomes less optimal and efficient. This is illustrated in scenario 22 (figure 35b). Another alternative was to place the group of seats in the middle of the room, as illustrated in scenario 23 and 24. These are found in figure 35c and 35d, respectively. This made movement for wheelchair users more difficult. If the wheelchair board the ferry before the other passenger it would be easier to manoeuvre inside the ferry. The flip chairs would be in the upright position and more floor space would be available. This would be difficult to guarantee as the ferry is to be operated without any personnel to guide the passengers. Thus, it was not considered a good option.

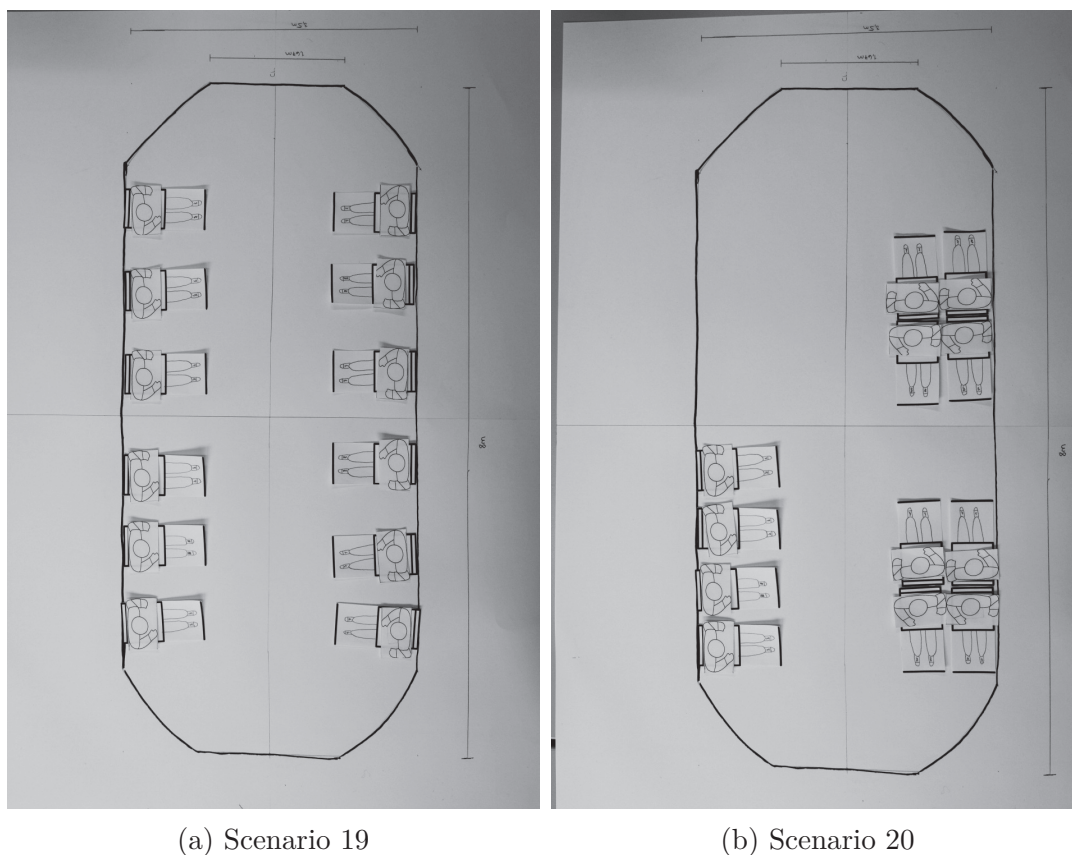
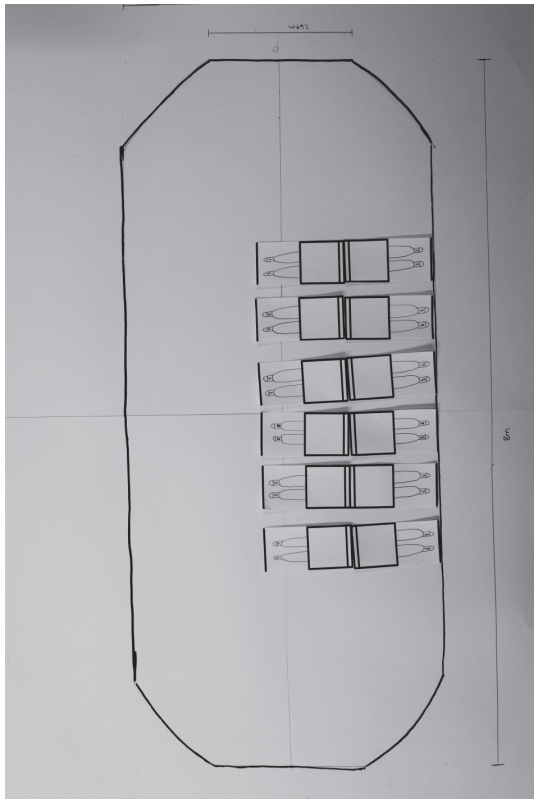
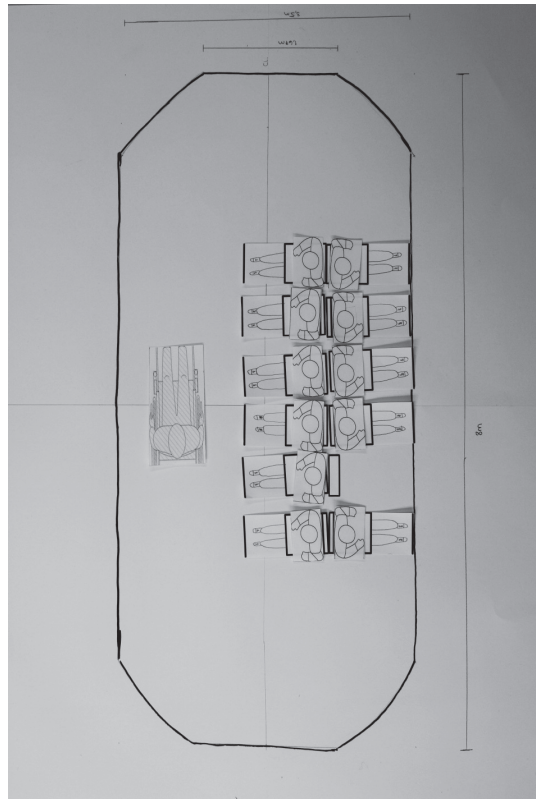

Figure 34: Model testing scenarios 19 and 20



(a) Scenario 21



(b) Scenario 22



(c) Scenario 23

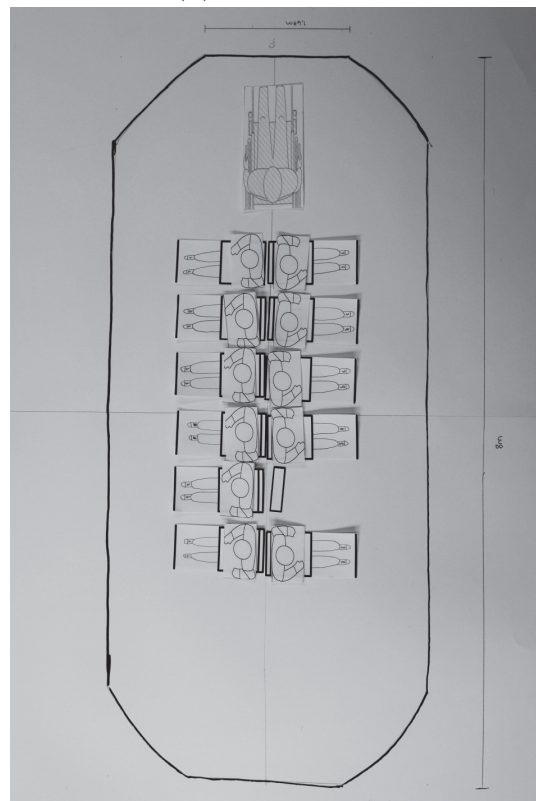

(d) Scenario 24

Figure 35: Model testing scenarios 21, 22, 23 and 24

### Scenario for the 10 x 3.5 metres Vessel

Finally, to test all relevant option, a vessel of 10 x 3.5 meter was examined. Based on the two other vessels, it could be concluded that 12 seats on board would not be an issue. Focus was therefore on the bicycles. As the vessel was two metres longer it would be possible to fit twelve bicycle on board. This could be done by placing passengers in four rows with three in each, as illustrated in Scenario 25 (figure 36). As the ship is 3.5 meter in breadth the bicycles could not be faced the other way. It was noted that the mid-ship is unnaturally long and would need adjustments. The arrangement should therefore be verified more closely if this were to be a relevant design.

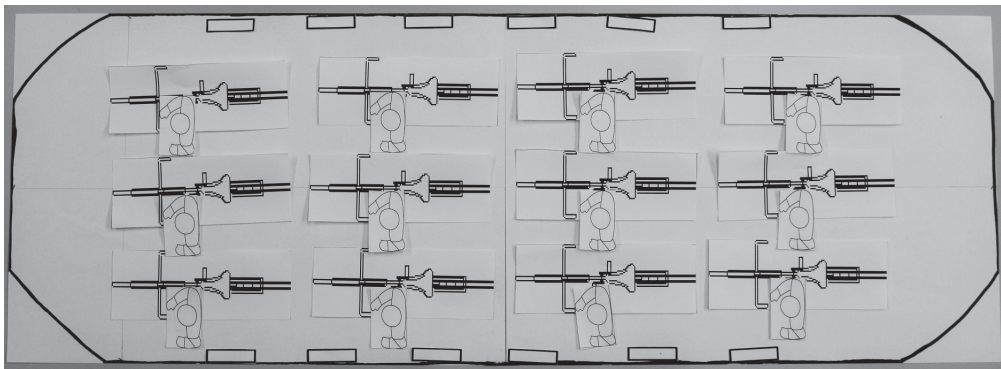

Figure 36: Model testing scenario 25

### Vessel Size Estimation

Based on the investigations performed in both model- and life size, it was concluded that a length of 8 m and a beam of 4 meter was suitable as initial dimensions. This secures multiple possible bicycle arrangements and decent comfort for the passengers as the room will not be cramped. The vessel size would not be set based on these investigations, but they provided the design team with valuable insight to what seems reasonable. Necessary area and volume on board will determine the final vessel size.

Several decisions were made about the vessel design, based on the investigations. The seats will be placed along the walls of the vessel to secure minimum loss of floor space. Bicycle racks will be mounted underneath each seat to secure organization of the bicycles. This is assumed useful if many bicycles use the ferry at the same time. The racks need to be double so that passengers can use the side that is most easily available. This to avoid them having to lift their bicycles into place on board. It was also decided to consider a guidance for passengers on the dock to encourage more efficient use of the ferry.

This will be re-evaluated at a later stage. All decisions based on the investigations will need further verification. It was considered that the mid-ship section might look different after the 3D – modelling of the hull.

## 6.9 Initial Estimation of Required Volume and Displacement

SBSD make use of Excel templates to determine the necessary area and volume of the vessel design. This study used the template for passenger ferries with necessary adaptations, including removal of several tables. The SBSBD template is found in appendix C.7. The template is organized in tabs. The tabs used in this study include:

- |                       |                         |
|-----------------------|-------------------------|
| 1. Mission Statement  | 5. Rooms and Tanks      |
| 2. Loading Conditions | 6. Weight Estimate      |
| 3. Passenger Space    | 7. System Summary       |
| 4. Ship Outfitting    | 8. Geometric Definition |

The tab "Loading Conditions" describes six relevant loading cases. These were added to get a better picture of the necessary area in the passenger lounge. The required area for the different passenger groups were collected from the previous investigation. The necessary equipment was listed in the ship outfitting- and the rooms and tanks tab. The weight and information on the equipment and ship outfitting was collected from various sources and implemented in the weight estimate tab. It was difficult to determine the exact technical needs this early in the design process. Information provided at this stage was only a rough estimate on the space requirement and displacement of the ferry.

The estimations on the battery and propulsion systems were based on a complete system available from Torqeedo. The system included a podded propulsor with propeller diameter 320 millimetres, and four 2.685 kWh batteries. According to the Torqeedo product catalogue, this system should be suitable for sailboats and motorboats up to ten tonnes (Torqeedo, 2017a). It was therefore assumed to be a reasonable first estimate. Information from this product catalogue was used to estimate the range of the system on the autonomous system. In the catalogue, the example vessel need and input to the propeller of 1.7 kW to drive 3.8 knots. The range is then 6.5 hours. It was assumed that the ferry in

this study would require 2.5 kW to reach the desired speed of 4 knots. The four batteries, with a total capacity of 10.74 kWh, gave a range of 4 hours and 12 minutes for the pod. This was included a 10 % margin to account for capacity loss due to low temperatures or similar scenarios. The total operational time would be approximately 8 hours and 24 minutes as there will be two pods on the ferry, only one used at a time. If both are used to navigate near the dock, the range would decrease. The notes from these calculations are found in appendix C.8 . Further, the total installed power was determined in the SBSB template. The basis was that the ferry would use two pods, each requiring four Torqeedo battery packs. It was also assumed that two extra batteries would cover the power demand from all other systems on board. The power demand calculation is found in the rooms and tanks tab in the template.

Once the required power was determined, an operational profile for the ferry was set. This is found in appendix F. It provides information on the power demand during the day and how much electricity the ferry operation requires through a year. Like for the SBSB template, this information would need adjustments once more detailed information became available. Therefore, a second version of profile will be made at a later stage with more accurate information. This will be found in appendix F. The operational time was divided into three levels, describing how many passengers would be expected in the time frame and how often the ferry therefore would transit. The level of low activity indicated that the ferry would make six transits, thus completing the roundtrip three times per hour. The medium activity level indicated twelve trips, and the high level indicated 20 trips per hour. The high activity level indicated that the ferry is making the roundtrip continuously with little stop time in between. The time per trip was estimated at two minutes to include time for maneuvering near the docks as well as the transit. The "Time" column sets the expected number of hours in each activity category during one day. The operational profile further calculates the total power demand through a year, based on the day - estimates and number of days in each category. The number of days in low-, mid- and high season was assumed by the design team. The number of weekends was set according to the number of weeks in one year. High season was set be 60 days as this is roughly the length of the summer and tourist season in Trondheim.

The low season was set to 120 days. This because the three winter months were assumed to have little traffic. Finally, the mid- season was set as the remaining days. The results are not accurate, but provide a good estimate for the project validation. Resulting numbers from the operational profile is presented in table 16 below.

Table 16: Calculation of ferry power demand for one year, based on 2.5 kW power demand for speed of 4 kn

|                | Days pr year | Demand pr day | Total pr year | Incl 15 % loss margin |
|----------------|--------------|---------------|---------------|-----------------------|
| High Season    | 60           | 29.1 kWh      | 1748 kWh      | 2010 kWh              |
| Mid season     | 133          | 22.9 kWh      | 3045 kWh      | 3502 kWh              |
| Low season     | 120          | 16.9 kWh      | 2023 kWh      | 2326 kWh              |
| Weekend        | 52           | 29.8 kWh      | 1548 kWh      | 1780 kWh              |
| Total (1 year) | 365          |               | 8364 kWh      | 9618 kWh              |

The complete propulsion system on board will have a capacity of 21.48 kWh from the eight batteries. The ferry is thus not able to operate the entire day without charging, expect in low season. It will therefore be essential that the ferry is able to charge in between trips in these periods. The estimations made about power demand will be reevaluated and verified in more detail at a later stage of the design study, using resistance calculations once the hull shape is set. It may then be relevant to increase the battery capacity to ensure continuous operation during high season. There is a possibility that the estimates made here are too low and that more power will be favourable.

Information in the SBSDD template include area, volume and weight of the different passengers, equipment and rooms on the ferry. It was assumed that the height below deck had to be 1.2 metres to ensure that the volume is large enough to fit all systems. This would be verified once more detailed information became available. Equipment on the main deck would not need extra space in addition to its own volume. This includes fire extinguishers, fire detectors and similar. This equipment is listed in the ship outfitting tab, and includes only the space for the equipment itself. The battery module below deck would require extra space around it to make inspection and maintenance possible. Therefore, equipment of this type is listed in the room and tanks tab of the template. This type of listing will ensure that the ferry holds enough volume for both the equipment and the extra space needed for easy access to perform maintenance and inspections.

All volumes were defined using square shaped rooms. In reality, the rooms will need to be shaped according to the hull. Small deviations to the volume in the SBSDD template was

therefore expected. This differs from the standardized way of using the SBSB template. Normally, coefficients are used to determine the necessary room size. For instance  $0.03 \text{ m}^3$  per kWh engine power. The coefficients are set from graphs made up using the existing fleet. The vessel in this study was too small to be able to use these curves. Volumes were therefore estimated based on existing equipment and assumptions. The weight of all equipment and outfitting was listed in the weight estimate tab. The emergency ladders along the hull were not listed as equipment in the template because they were included in the weight of the hull. This information was useful to get an early estimate of the vessel's displacement. It was used later when making the 3D model of the hull to ensure that the volume displacement was sufficient. This will be discussed in section 7.1.

The initial estimations from the SBSB template indicated that the ferry's main dimensions would be length of 8-10 metres and beam of 3-4 metres. The displacement is estimated to be 4.6 tonnes including the passengers. Further iterations on the design were necessary to get a better estimation. The initial design was at this stage set to have length eight metres and beam four metres. This is a reasonable estimate based on the results from the area requirement investigations as well. As the SBSB process is untidy and unpredictable, information in the template was changed several times during the study as new information became available. Two versions are presented in appendix C.7. The first one presented is the result from this first iteration, while the second is the resulting version at the end of the study.





## 7 Detail Design

This chapter will discuss the design decision making process where the final design is determined. The process was illustrated using the design spiral in the methodical approach description. The hull shape will be designed, together with the superstructure. Further, the required space on board will be re-evaluated to ensure that necessary modifications are made on the hull. Finally, the arrangement of equipment and outfitting will be set.

### 7.1 Development of 3D Model

The 3D – model of the hull was made using the 3D- modelling software Delftship. Based on results and discussions from the concept development the initial model was to be made 8 metres long and 4 metres in breadth. A 2D face with control points was used as the starting point for the modelling. This face is displayed in appendix D.1. The model was made on the designers’ intuition and discussions through several iterations.

Two types of hulls were considered. The first hull type has the keel raised in the stern. As the vessel is symmetric, it would have this shape in both ends. In principle, the ferry does not have a stern, but two bows. The design is illustrated in appendix D.2. Benefits related to this shape include increased wake and less risk that the propeller is injured in case of grounding as the propeller’s draught is less than the lower keel. However, the increased wake is often not as favourable as assumed because it leads to increased whirling. This is less optimal for the propeller and often the gain does not outweigh the disadvantage. An important disadvantage with this hull shape is that it requires a larger draught than a conventional hull. For the podded propulsion to fit under the raised keel, the draught will have to be more than 0.5 metres due to the shape of the hull. If less, the propeller will no longer be submerged. The stability of the vessel will also be affected by this hull shape. Less buoyancy in the ends of the hull enables trim. It would also have less buoyancy in general and be more exposed to movements of weights on board. A conventional hull, as illustrated in appendix D.2, secures proper flooding of the propellers as they will be located under the vessel’s lower keel. The hydrodynamic qualities of the two hulls will not differ significantly. To avoid the potential problems related to too low draught and poor stability, the conventional hull was considered the best option. It was further decided

that the vessel were to be made without an additional keel. It was considered that if the bottom of the vessel was not entirely flat, but in a slight v -shape, this would ensure sufficient directional stability. An additional keel could also increase the effects of currents coming in from the side. It would be possible to mount a keel to the hull at a later stage if necessary.

The first stage of the 3D – modelling was to use the 2D face to shape the profile of the vessel. As this vessel is to be symmetric, the face was shaped as half the vessel. An illustration of this face is found in appendix D.3. This half vessel was mirrored across the transverse axis once the desired shape was achieved. Mirroring across the longitudinal centreline is performed automatically in Delftship. Thus, only half the vessel needs to be modelled. In this case, only a quarter of the vessel was modelled.

Once the profile was satisfactory, necessary points were moved to shape the keel and bow area. This gave the shape as seen in appendix D.4. Focus was put on maintaining a long straight midship to secure sufficient space on the main deck. The hull was mirrored over the transverse axis to display the complete hull. This first iteration is seen in figure 37.

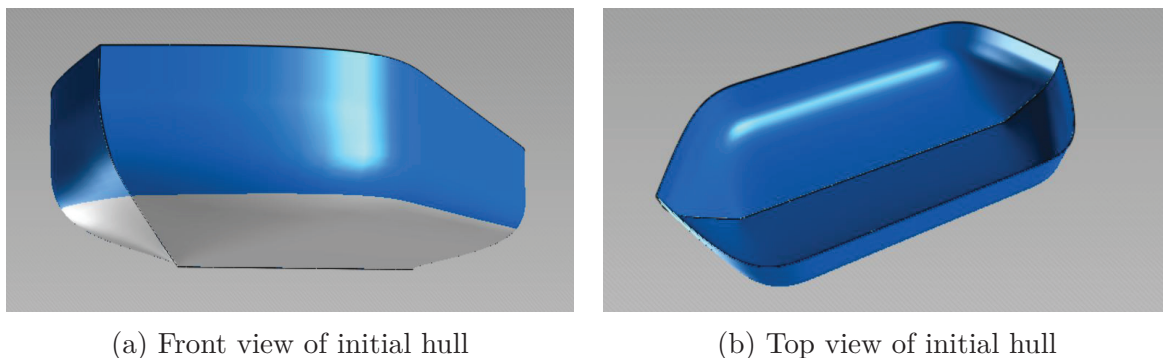

Figure 37: Illustration of initial hull shape

Discussion in the design group concluded that the initial hull model was unsatisfactory. The hydrodynamic qualities were considered unacceptable. The hull was shaped with few variations in the curvature in the bow area. The aesthetics of the design was also unsatisfactory due to the shape, similar to a bath tub. It was decided to modify the bow area so that it would be more hydrodynamic. The front face of the bow was made sharper and curvature was added along the sides. The new model is displayed in figure 38. The straight midship area was also modified as it was too square shaped in the initial model and the aesthetics were bad. The midship section on the initial model is

seen in figure 39a. The midship section of the new model is seen in figure 39b. The moderations to the model were made in multiple steps through discussions in the design team. Particularly the midship section needed several iterations before the desired shape was achieved. Iterations are common in a design process, and enables the team to be open for new and unexpected possibilities that may not have been considered before. These design modifications resulted in a vessel with length over all 8.3 metres and beam 4 metres.

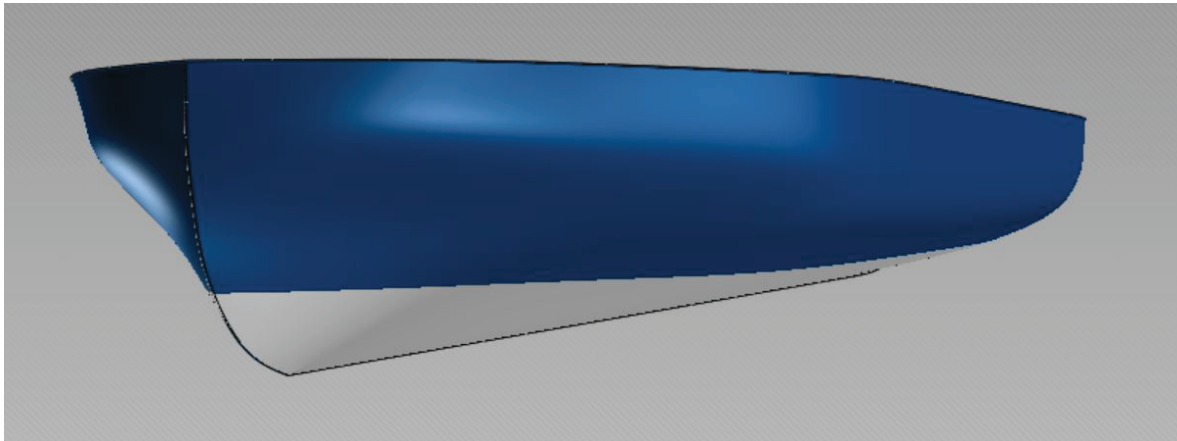
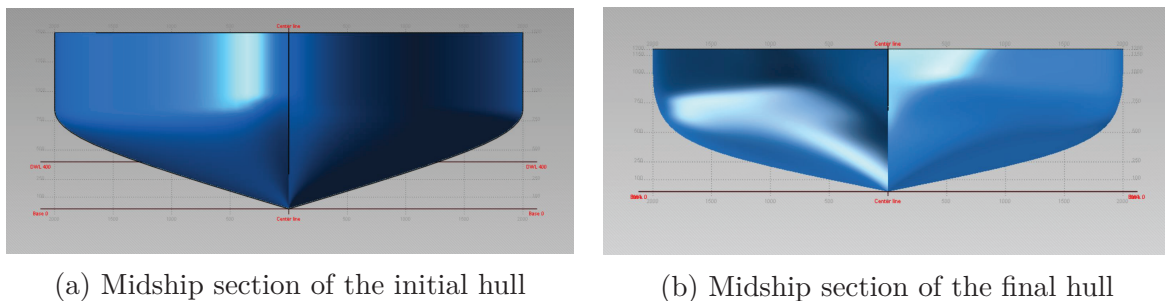

Figure 38: Illustration of final hull model



(a) Midship section of the initial hull

(b) Midship section of the final hull

Figure 39: Illustration of midship sections

The first round of changes to the hull model was completed and verification of the design was necessary. The design hydrostatics report in Delftship revealed that the main deck had an area of  $27.2 \text{ m}^2$ . The required area was estimated to approximately  $24 \text{ m}^2$  in the SBSB template. This area includes only the passengers. Area on the deck must also be reserved for life vests and fire extinguishers. These make up approximately  $5 \text{ m}^2$  according to the current SBSB template, indicating a total area of  $29 \text{ m}^2$ . As this technical information was yet not validated, the study moved forward with the current design. It would be reconsidered once the superstructure design was set. This would affect how much

of the deck space could be utilized. It was assumed that there would be sufficient space underneath the main deck for all necessary technical equipment. None of the required equipment were particularly volume demanding, except the batteries. In addition, no fuel tanks or fresh water tanks would be necessary. A weight of 3.1 tonnes were added to the 3D model to check the draught. As the intention was to get an estimate, the weight was evenly distributed across the hull. This weight estimate was found using Delftship. Plate thickness and material density for aluminium was added to the layers in the model and the weight was calculated. This weight was further added to the equipment and outfitting weight. The initial draught estimate was 0.4 metres. Further validation of the model was planned at a later stage in the study, once detailed information about the technical equipment and superstructure design was available. A curvature plot was collected from Delftship, indicating the complexity in building the hull, see figure 40. The green areas in the plot mark what is considered developable by Delftship. The red areas are not developable. As seen from the figure, large parts of the hull is not developable. This is due to the double curvature in these areas. Before this vessel can be built, an expert on building aluminium vessels would need to modify the hull to make it developable. This is not investigated in this study and is considered part of the further work.

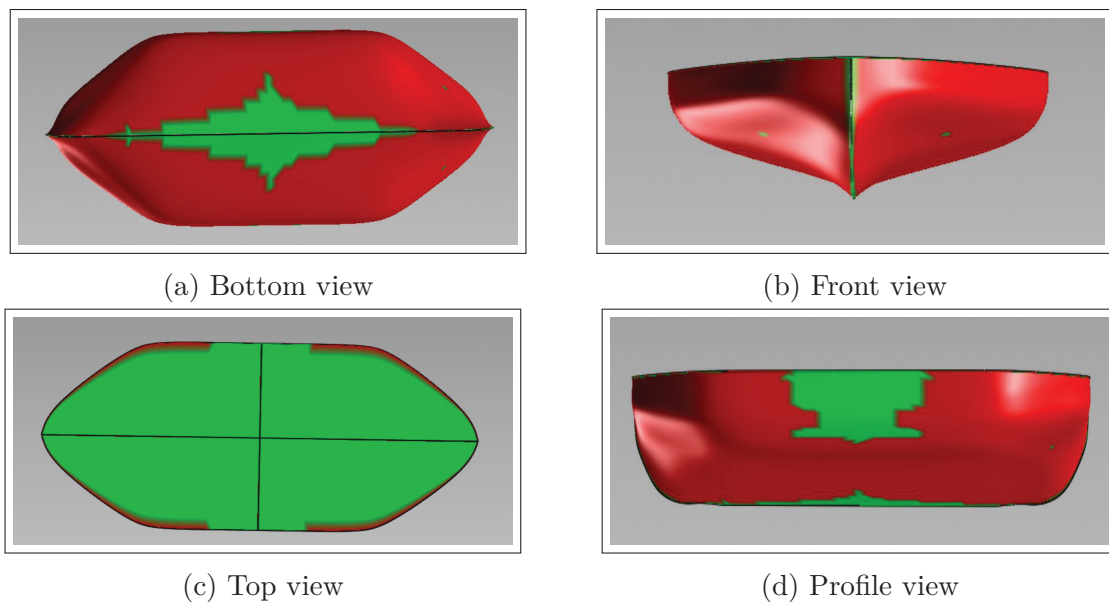

Figure 40: Plot illustrating curvature on hull, red implying double curvature

## 7.2 Design of Superstructure

The superstructure design was determined using the weighted objective method on simple models illustrating the viable solutions. Three generic options were considered including no roof on the ferry, semi-open with roof and a closed superstructure. The alternatives are sketched in appendix D.5. Twelve evaluation criteria were used for the ranking. All criteria were given a weighting, representing their importance for the result. The twelve criteria include passenger comfort, need for cleaning on board, maintenance need, aesthetics, user friendliness, cost, autonomy friendliness, perceived space on board, windsail, damage stability, evacuation efficiency and perceived safety. The complete ranking of the alternatives is shown in table 17.

Table 17: Ranking of superstructure alternatives

|                       | Concepts         |        |       |                               |       |                    |       |
|-----------------------|------------------|--------|-------|-------------------------------|-------|--------------------|-------|
|                       | 1<br>Open design |        |       | 2<br>Open design<br>with roof |       | 3<br>Closed lounge |       |
| Selection<br>Criteria | Weight<br>[%]    | Rating | Score | Rating                        | Score | Rating             | Score |
| Comfort               | 8 %              | 5      | 0.4   | 6                             | 0.5   | 8                  | 0.6   |
| Need for<br>cleaning  | 3 %              | 8      | 0.2   | 7                             | 0.2   | 5                  | 0.2   |
| Maintenance           | 7 %              | 9      | 0.6   | 8                             | 0.6   | 6                  | 0.4   |
| Aesthetics            | 8 %              | 7      | 0.6   | 8                             | 0.6   | 4                  | 0.3   |
| User<br>friendly      | 10 %             | 9      | 0.9   | 9                             | 0.9   | 7                  | 0.7   |
| Cost                  | 10 %             | 10     | 1.0   | 8                             | 0.8   | 5                  | 0.5   |
| Autonomy<br>friendly  | 15 %             | 8      | 1.2   | 9                             | 1.4   | 9                  | 1.4   |
| Sense of<br>space     | 6 %              | 8      | 0.5   | 8                             | 0.5   | 6                  | 0.4   |
| Windsail              | 10 %             | 10     | 1.0   | 9                             | 0.9   | 7                  | 0.7   |
| Damage<br>stability   | 10 %             | 7      | 0.7   | 7                             | 0.7   | 5                  | 0.5   |
| Evacuation            | 6 %              | 9      | 0.5   | 7                             | 0.4   | 5                  | 0.3   |
| Percieved<br>safety   | 7 %              | 5      | 0.4   | 6                             | 0.4   | 8                  | 0.6   |
| <b>Total Rank</b>     |                  |        | 8.0   |                               | 7.9   |                    | 6.5   |
| <b>Rank</b>           |                  |        | 1     |                               | 2     |                    | 3     |
| <b>Continue?</b>      |                  | No     |       | Yes                           |       | No                 |       |

Autonomy friendliness was considered the most important criterion as this is an essential part of the design and its functionality. Further, user friendliness, cost, windsail and damage stability was considered equally important. The criterion considered least important was the need for cleaning on board.

In the evaluation of the concepts each criterion was considered subsequently and the concepts ranked according to each other. The closed concept performs best regarding comfort as the closed passenger lounge will shield the passengers from the wind and rain. The open concept was rated lower than the semi-open, as a roof will contribute to the passengers' comfort. The open concept was considered the best with respect to the need for cleaning on board. An open solution will enable rain to wash away much of the dirt that may be on board. With a closed lounge, litter and dirt will gather up inside the ferry.

The level of maintenance necessary will be the lowest on the open ferry concept. This because there will be fewer parts on board that require maintenance. The closed ferry concept gets the lowest score. The doors ensure the closed structure will require regular maintenance to function properly. Due to wheelchair users, the doors need to be able to open using a button instead of a door handle. Increased size of the superstructure also implies a higher level of maintenance. The closed structure will look more box shaped than the two more open structures. It therefore was ranked the lowest of the three regarding aesthetics. The open structure with roof was considered the best alternative as it will look both inviting and comfortable.

Considering the user friendliness of the three concepts, the two open concepts were ranked equally good. The closed structure was considered less optimal as the closed doors makes efficient passenger flow more difficult. It may also be challenging for wheelchair users to manoeuvre. An open structure removes this difficulty. The cost will increase with the need for material and equipment. The open structure was thus the best performing alternative in this category. All concepts were in principle equally adaptable to the autonomous system. The system would be more exposed to vandalism on the open structure. No roof enables passengers to tamper with the sensors. This concept was therefore given a slightly lower score than the two other concepts.

Both regarding the sense of space on board and the damage stability, the two open concepts were considered equally good. The closed structure was in both cases considered the weakest option. Partly because the room would feel smaller if all walls were closed. If the room was filled up with for instance twelve bicycles, the impression would be even worse. It was also considered less optimal regarding damage stability as it may impose a large risk in case of water intrusion. It would be necessary that the lounge was completely closed and waterproof during transit to prevent this risk. One minute transit time makes this an unpractical and unnecessary option. In addition, the close superstructure would have a higher centre of gravity than the two other options.

The completely open ferry was the best performing in both the windsail- and evacuation categories. This because the simple structure would provide little windsail in addition to enabling fast evacuation in case of an emergency. The passengers could simply climb over the fence. The closed structure was the least favourable option as it would have large windsail in all directions. It would also make evacuation slower as the passengers would be required to exit the ferry through the lounge doors. Finally, the perceived safety was considered best maintained in the closed ferry. The superstructure would shield the passengers from the wind and rain. The completely open ferry was considered least favourable as the passenger would be exposed to the weather. The results from the ranking reveals that the completely open design is the best. The open ferry with roof is the second-best option. As there was only 0.1 point between the first and second best alternative, both were considered. The open ferry with a roof was chosen for further development due to its high score in the autonomy friendly category. No roof on the ferry would make frames necessary in order to get the sensors placed high enough to avoid tampering. The sensors used to register traffic and obstacles in front of the ferry will be able to register 15 °upwards and downwards. It will therefore not be sufficient with one sensors on the middle of the ferry, as the passengers on board will block its view. A roof would enable two sensors to be placed towards the ends of the vessel, like discussed previously in section 6.6. These would be able to look over the passengers standing on the ferry, but not right in front of the bow. To solve this problem, other sensors or cameras could be mounted on the two bows. These may be similar to sensors used on cars to register the surroundings when reversing. The sensors on the bow was to be placed lower than the ramp, to keep them out of passengers reach. This to avoid sabotage.

Three design suggestions were made using Delftship. All alternatives had roof, the difference between them was how the roof was constructed. The first alternative used small pillars to hold the roof. The second had a wide pillar, while the third had walls on the longitudinal side of the ferry. The concept sketches are presented in figure 41. The first concept was ruled out because it would be too open. The fence around the ferry would need to be like a wall to get the seats in place. This would ruin the open design solution. The third concept was also discarded. The structure was considered to have too large windsail. In addition, it did not have the aesthetics in place. Thus, the second alternative was the best. The design team was not entirely pleased with this design. The single pillar made it necessary to have a tight fence at the mid part of the vessel to fasten the seats. This would give sharp edges in the design. At the same time it was desired to have some parts of the vessel with a more opens fence structure. To solve this, the design was changed to two pillar being connected at the middle of the vessel. This gave room for parts of the fence being open while at the same time providing walls to attach the seats.

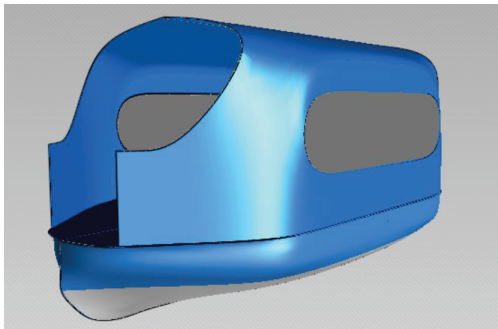

(a) Closed structure with open ends

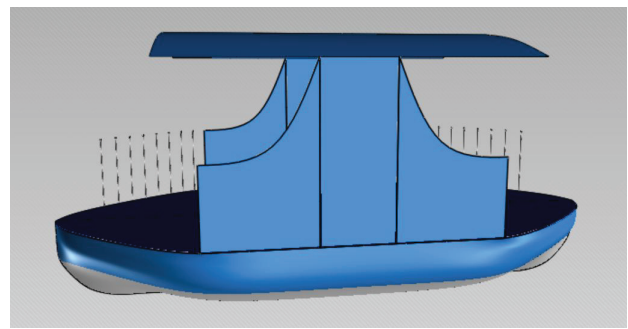

(b) Roof supported by single wide pillar

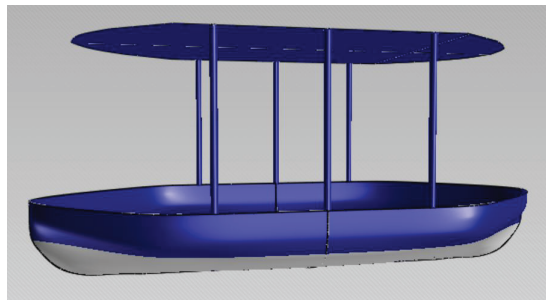

(c) Roof supported by poles

Figure 41: Concept suggestions to semi- open superstructure



More accurate measurements on the superstructure design revealed that it would not be possible to fit twelve seats with the current design. This, combined with the fact that the main deck was too small compared to the information in the SBSB template, made it necessary to increase the vessel size. The ferry was made 0.7 metres longer by increasing the straight midship. This made the superstructure walls longer so that all twelve seats would fit. In addition, the deck area increased to 30.8 m<sup>2</sup> giving enough space for all equipment and passengers according to the SBSB template. The vessel now had length overall to 9 metres. The new hull with superstructure is illustrated in figure 42.

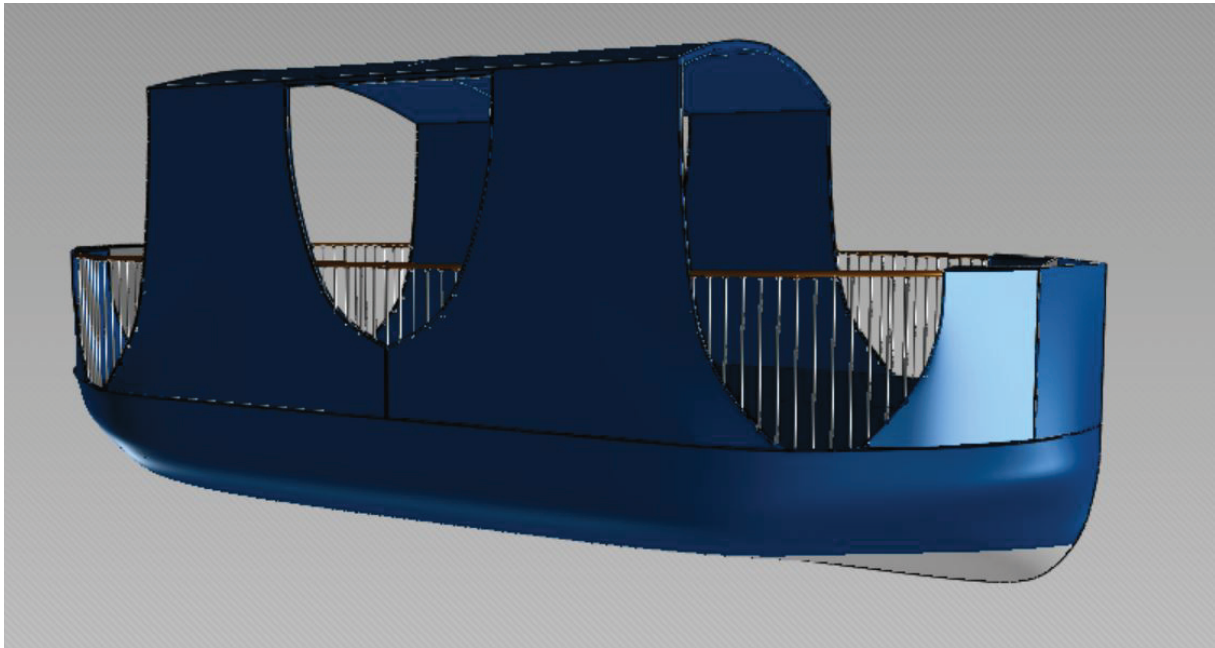

Figure 42: Illustration of the final design of the superstructure

When the superstructure and mooring design was set, it was implemented with the hull model in Delftship. Because the hull model was made without considering the ramp or superstructure, the three parts did not fit optimally together. As seen in figure 43a, the ramp made the bow of the ferry look unnatural. If the hull were to have the same shape, the ramp would need to be shaped after the hull as illustrated in figure 43b. This would imply a more complicated mooring arrangement as the dock itself would need to be shaped according to this rounded ramp. Functionality was prioritized before aesthetics and the bow design was therefore changed. As the complete 3D model in Delftship was used mainly for illustrative purposes, these adjustments to the hull were made only in the general arrangement drawings. The actual shape of the bow is thus illustrated in these figures. This will be discussed in section 8.3.1. The small adjustments make the

calculations performed on the hull in Delftship inaccurate as the actual design will differ slightly. The weight distribution will still be approximately the same and the deviation was considered minimal. Most of the changes were above the water line, and it was considered that calculations on resistance would be at a satisfactory level even though the old model were to be used.

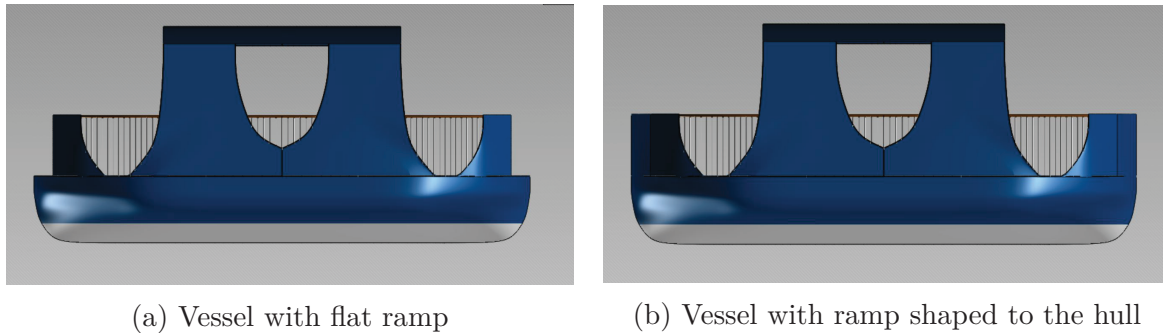

Figure 43: Illustration of the vessel using different ramp designs

### 7.3 Re-evaluation of Power Supply

To get a better understanding of using batteries as energy supply on the ferry, the marine battery company Plan B Energy Storage (PBES) was contacted. The design team visited the company's facilities in Trondheim, getting a tour of the factory and lectures on how their battery modules work. Notes from the visit can be seen in appendix D.6. PBES recommended using either their 200 V or 400 V modules on the vessel. They also recommended having two modules in separate rooms for redundancy. The 200 V modules would need new software developed and the best choice was therefore the 400 V modules. These would not need additional adjustments and could easily be delivered by PBES on request. The cost of two such modules would be approximately NOK 315 000.

The 400 V modules recommended by PBES have an energy content of 26 kWh. The total energy available on the vessel would thus be 52 kWh, using two modules. This is double the amount estimated from the Torqeedo system. PBES believed this would be more suitable for the ferry and that Torqeedo may not be powerful enough. Comparison with an 8.2 metres long recreational vessel with top speed 6 knots indicate that this is right. The comparison vessel weights approximately 3.5 tonnes and have a 58 horsepower (HP) engine (Pettersen, 2017). The Torqeedo system is estimated to equal a 20 HP thrust system and may thus not be enough. If the vessel speed is increased to 5 knots, the

required input power would be significantly higher. As this is the actual speed limit in the area, the vessel should be able to reach this speed if necessary for instance in an emergency. The operational profile also indicated that the vessel would operate for up to eight hours in continuous operation. Extra power would help secure that the ferry does not need to stop operation mid day to charge.

In addition, only two batteries, with a total capacity of 5.370 kWh, were currently included to supply the remaining systems on board. More batteries would therefore most likely have been necessary if the Torqeedo system were to be used. Increasing the number of batteries was not a satisfactory solution as they take up much space. Further, there were no guarantees that the batteries would be able to deliver the necessary power to the propeller, if the propeller was changed to something other than Torqeedo's own system. Each of the PBES modules weighs 591 kg. By changing from the ten Torqeedo batteries to the two PBES modules, the weight increases with 939 kg. As there are few other weights on the vessel, this will not be a problem. As the battery modules will be placed low in the hull and likely close to the flotation centre, it may improve the stability of the vessel. The PBES batteries are also approved for marine use (Eide, 2017).

Another advantage using PBES as battery supplier is their presence in Trondheim. Using Torqeedo for power supply would imply contact with maintenance in Oslo as they do not have offices in Trondheim (Torqeedo, 2017b). Should there be problems with the PBES battery modules, they would be able to respond at much shorter notice. Another advantage is that PBES already is a supplier for larger businesses. Torqeedo targets the private market, and the logistics concerning the maintenance may therefore be more complicated on a project of this scale. They are also expensive compared to PBES. The price increase from approximately NOK 235 000 to NOK 305 000 (Prices calculated using currencies were USD 1 = NOK 8.4 and EUR 1 = NOK 9.4 ). If the same capacity were to be obtained from the Torqeedo battery packs, the cost would be NOK 470 000 . Thus, the PBES battery module is cheaper per kWh. It is also tailored for use with a cooling system. This may pose a challenge for the Torqeedo system as they are designed to be self-cooling and the load may be unusually large in this setting. PBES was based on this discussion considered a more reliable supplier, in addition to being cheaper and more available than Torqeedo. From this point, the PBES modules were used as design equipment for the ferry. The battery room and related equipment would be set according

to these modules and recommendations from PBES. It was also recommended by PBES to use inergen gas as fire extinguisher in the battery room, instead of CO<sub>2</sub>. They could not guarantee that the Norwegian Maritime Authority would approve this, but as it has the same functionality as CO<sub>2</sub> with less risk of harm to human life, it was concluded to investigate this option.

The batteries need maintenance once a year to check the cells and to change the seals for the water cooling. The modules may be opened so that single cells can be removed and inspected, instead of removing the whole module. The batteries have a lifetime of ten years, but it will be possible to change single cells if this is sufficient. It was also informed that the batteries are best used with short and frequent charging periods, rather than long charging breaks during the day. This will fit the operational profile of the ferry as it is estimated to get frequent 5-10 minute breaks at the dock. A coolant and a heat exchanger would be necessary together with a pump to secure cooling of the battery modules. A conventional heat exchanger would take in sea water and run it through the heat exchanger inside the hull to cool the cooling liquid. An outboard heat exchanger was recommended by PBES. This would avoid the risk of litter and particles in the cooling liquid as no sea water would be taken into the system.

## **7.4 Revision of Required Volume and Displacement**

When the generic part of the design was set, more details were to be determined about the rest of the ferry systems. Much of the technical equipment is inspired by specific models found by browsing different suppliers online. It was not intended that the suppliers listed as references will be used as suppliers for the ferry. More detailed information will be necessary from the potential suppliers to ensure that all equipment will function properly together and be installed correctly. There may be assumptions made in this study that do not comply with requirements from the supplier. This needs further validation before suppliers are set. The only supplier suggested in this study is the battery supplier. This is because they provide the service needed at a reasonable price. Still, it may become relevant to consider other suppliers if the project is taken further at the end of this study. This section describes the changes made to the SBSDB template when additional information became available. The assumptions made in the first version of the template was used

as basis when finalizing the details. The updated version of the template resulting from decisions in this section is found in appendix C.7. It should be noted that this version includes minor changes made later in the study as well. As these changes were few, they were included in this same template for simplicity. These changes include the weight of the hull, superstructure and main deck.

It was at this point concluded that the volume between the keel and 20 cm above keel was to be considered as void space. The equipment would now have an area to be mounted on by creating this imaginary tank top. It would make it easier to later verify that all equipment had sufficient space within their rooms once this was imported to the general arrangement drawings. Here the area of the tank top could be easily investigated and necessary changes could be implemented. The height of all equipment was thus adjusted to one meter in the SBSB template except from the thrusters that will go all the way down and through the hull. The volume requirement for the rooms are set using the area multiplied with the height of the room, thus a square. As the hull shape will make all square rooms impossible to achieve, the actual volume of the rooms in the 3D model will vary from these SBSB template numbers despite the area being the same.

### **Battery Room Design**

The battery modules from PBES are cooled using ionized water. The water should hold a temperature of  $18 \pm 3$  °C. This is to ensure the lifetime and safety of the battery cells and avoid dangerous gas leakage from the modules. During the winter months, the problem may not be to keep the batteries cool, but rather warm enough. Thus, heating of the cooling water must be possible. The cooling systems needs a circulation pump to transport the water around the system (Plan B Energy Storage, 2017). Two pumps were included in the cooling system to achieve redundancy. No expansion tank was necessary. Temperature and pressure sensors will also be necessary for the system to maintain even temperatures (Plan B Energy Storage, 2017). An outboard heat exchanger will be used, as recommended by PBES. This make use of the sea water to lower the temperature of the cooling fluid. Pipes connected to the cooling system are mounted underneath the hull. As the cooling liquid flows through the pipes, sea water flowing on the outside of the pipes will cool down the contents of it. The cooling water then flows back into the cooling system and into the battery modules to cool them. This solution was considered favourable to the alternative of taking seawater into a heat exchanger inside the hull as

a seawater intake would be avoided. The intake could easily be clogged by garbage and things floating in the channel, requiring a high level of maintenance. The downside of the copper-nickel pipes underneath the ferry is their exposure in case of grounding and increased resistance. With the limited operating area in the channel and low transit speed, this should not be a problem as the increase in resistance is low. The increase in resistance will be low. A heater was considered installed to secure the batteries against low temperatures during the winter. It was assumed unnecessary, but space was reserved for a heater in case it were to be installed at a later stage.

To determine the exact cooling demand, PBES would need a detailed load profile for the system. As this was not available, rough estimates were made to ensure enough space on board for the system, and that it will not affect the stability and displacement of the vessel considerably. The room for the cooling system was set as 0.75 m in the longitudinal direction. It was set to take up the entire beam of the vessel and be 1 metre in height, giving the room a volume of approximately 3 m<sup>3</sup>. This room were to be place in the longitudinal centre of the vessel. With the cooling system placed in the middle with one circulation pump on each side, the effect on the vessel's stability would be minimum. Should the estimated system weight of 25 kg turn out to be wrong, the negative effects would not be significant.

Further, the battery rooms were designed based on information from PBES. The battery module size is illustrated in figure 44. In addition, 0.7 metres were required in front of the module. This is so that the battery cells may be taken out for service. The battery rooms were based on this information given a length of 1.6 metres. The beam of the room would equal the vessel beam of four metres. In addition to the battery module, a bilge pump would also to be fitted in the room. This pump was intended only for the battery room to ensure that it is always clear of water, should there be any leakage. The battery room was designed to be water- and oil proof as required by regulations. The two battery rooms were placed on each side of the cooling system room. This way the weight on board the vessel is symmetrically placed achieving the best possible stability and redundancy.

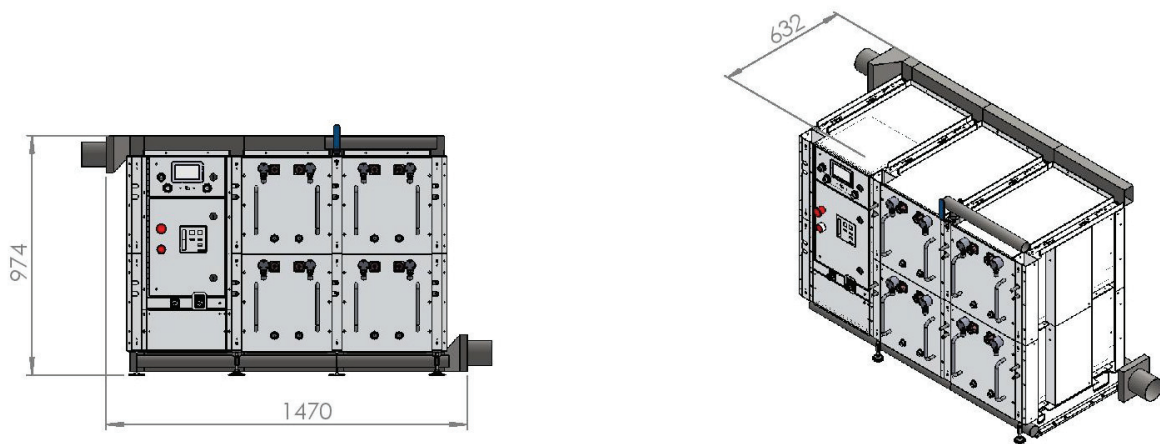

Figure 44: Illustration of battery module delivered by PBES (Plan B Energy Storage, 2017)

### Thruster System

Resulting from the new battery system, the thruster arrangement was re-evaluated. It was considered that the propeller from the Torqeedo system is not originally a steerable pod and an electrical engine for steering would be needed in addition to secure this functionality. Therefore, new alternatives were investigated to find a system more suited for the intended tasks. An azimuth thruster from Aquamot was chosen as propulsion system. As little information was available at this stage regarding the necessary propulsion power, the system most similar to the Torqeedo system was chosen. This included an azimuth thruster (Model UF100e) with input power 10.87 kW and output power 10 kW. The thruster weight is 43 kg. In order to ensure that all system parts were included in the weight calculations, it was rounded up to 50 kg in the SBSB template. Aquamot did have information available on the size of the thruster system. Attempts to contact Aquamot to obtain this information were unsuccessful and they were considered unreliable as possible supplier. Thruster room size was therefore assumed to be 0.9 x 2.03 x 1.2 m giving it a volume of approximately 2 m<sup>3</sup>. This is a significant increase from the first estimations in template version 1 (see appendix C.7). As it appeared to be plenty of space below main deck, this would not be a problem. More details on the thruster size should be collected as soon as possible.

## Fire Extinguishing System

To determine the specifics for the fire extinguishing system, two possible suppliers were contacted via e-mail. Nortronik was the only to reply, and gave useful input for the design. Based on their recommendation, the fire extinguishing system was changed from Inergen gas to using Novec 1230. This is a fire protection fluid with qualities similar to Inergen. It is not harmful to either people or the environment(3M, 2017). Novec was preferred due to its low storage pressure, compared to Inergen. Instead of a tank pressure of 200 - 300 bar, the Novec system use a pressure of around 25 bar. The liquid may also be transported without being pressurized at all, which makes it easier to obtain more if needed for maintenance. The liquid evaporates once it is dispersed into the room through nozzles and will not damage the equipment.

To determine the required amount of Novec 1230, information from a similar project provided by Nortronik was used as basis. This report is included in the attached file showing the references in pdfs. It is in this folder called "Nortronik, 2016 - Prosjekt 5096". The only part used directly was information about the volume to liquid ratio of the room in the report. The room had a volume of 29.6 m<sup>3</sup> and required 43.1 kg Novec 1230 (Nortronik, 2016). Assuming a linear proportionality, the Novec to volume ratio was 1.45. Each battery room had an estimated size of 6.4 m<sup>3</sup> based on the initial arrangement. The required amount of Novec was 9.28 kg. This amount was rounded up to 10 kg for simplicity. It should be noted that this volume was estimated as a square. Using the table of tank sizes provided by Nortronik, the tank size was estimated to be 16 litres (Engebø, 2017). This tank could hold 9 – 18 kg of Novec liquid. It was decided that the hydraulic generators and the thruster rooms should also have automatic fire extinguishing. Therefore, two more bottles were required as one bottle can serve only one room.

The hydraulic generator room was 1.2 m<sup>3</sup> after adjustments were made in the SBSB template. The weight of the system was also increased from 26 to 30 kg to account for piping and other various parts. The adjustments in volume were made to secure sufficient space around the hydraulic generator for maintenance and inspection. The new hydraulic generator room size indicated a need for 2 kg of Novec when rounded up. The thruster rooms would each need 3 kg of Novec for fire extinguishing as they both were 1.9 m<sup>3</sup> in volume after the adjustments. With this, it was concluded to install three tanks in each fire extinguishing room. One 16 litre tank containing 10 kg of Novec and two 5 litre



tanks both containing 3 kg Novec. The 5-litre tank was the smallest one available, with minimum content 3 kg. It was estimated that the 16-litre tank weighed 12 kg when empty. The 5 litre tanks were estimated at 3.75 kg. This was based on the information that an 81 litre tank weighs 61 kg when empty (Nortronik, 2016). This gives the weight/volume ratio of  $61/81 = 0.75$ . This information was collected from the case data sheet provided by Nortronik. The room containing the Novec 1230 tanks were estimated to have a volume requirement of  $0.13 \text{ m}^3$ . Complete notes from the Novec calculations are found in appendix D.7. A second version is also found there as the numbers were adjusted at a later stage. A summary of the novec system is presented in table 18

Table 18: Summary of the amount Novec 1230 used for fire extinguishing

| Room       | Room Size [ $\text{m}^3$ ] | Amount Novec [kg] | Tank Size [l] |
|------------|----------------------------|-------------------|---------------|
| Battery    | 6.4                        | 10                | 16            |
| Hydraulics | 1.2                        | 3                 | 5             |
| Thruster   | 1.9                        | 3                 | 5             |

### Bilge Pumps

Each bilge pump needed to have capacity of minimum 75 litres per minute according to the NBS. As the one used for the original estimation did not have this capacity, new estimations were necessary. To estimate the weight and space requirement, an ordinary bilge pump with capacity up to 95 litres per minute was used. This is delivered by Xylem Water Solutions UK (Xylem Water Solutions, 2017). It should be noted that this may not be the best supplier for the vessel outfitting, and suppliers should be considered at a later stage. It was originally estimated to use one bilge pump for the entire ferry. The NBS requires one bilge pump in each room or one that can clear all rooms through piping. It was here chosen to use one bilge pump for the battery room and one for the rest of the rooms below deck. To achieve a satisfactory level of redundancy, the system was mirrored so that there will be a total of 4 bilge pumps. One in each battery room, one in the aft of the vessel and one in the bow. This will not be a substantial part of the total cost.

In addition, the NBS require an emergency bilge pump in case the originals should fail. This may be manual or electric. If electric, it should to be connected to a different power source than the rest. To maintain the symmetry of the vessel arrangement, it was concluded to install two emergency bilge pumps. These would be of the same type as the regular bilge pumps. As they needed to have separate power sources, the regular bilge

pumps were to be connected to one battery module and the emergency pumps to the other. The emergency bilge pumps and the battery room bilge pumps were to be placed in the room together with other equipment. Therefore, four of the pumps to be installed were listed as equipment in the SBSB template. The two remaining pumps were listed as bilge pump rooms as they were to be mounted in separate rooms and therefore needed to account for the necessary extra space. The pumps were estimated to require a volume of  $0.03 \text{ m}^3$  and the pump rooms required  $0.7 \text{ m}^3$ . Estimated weight of each pump was 1.5 kg.

### Other Systems

More accurate information on what other suitable equipment exists for the vessel, was found using various sources online. Most of the sources were supplier web sites. Some information was also collected by contacting the suppliers directly to get their recommendations according to vessel size and functionality. The volume reserved as void in the first version of the SBSB template was adjusted to zero. This because it was not necessary to reserve space for void, it would adjust itself when the arrangement was set. The number of adult life jackets was increased to eighteen after more thorough investigations of rules for rescue appliances on ships. It was required to have 1.5 times the number of passengers (Lovdata, 2014). As the vessel for the most part will be used by adults, the number was increased. There would still be twelve childrens' life jackets on board as well. The rules require 2.5 % of these to be infant life jackets (Lovdata, 2014). Therefore one of the twelve childrens' life jackets will be suited for children younger than one year.

A conventional anchor was set as an emergency solution early in the design process. Its weight was originally pure assumptions from the design team. Once the vessel design was set in more detail the anchor weight could be determined using the guidelines in the NBS. The anchor weight and rope length was determined using the estimation curve from the NBS. The measurements from the curve is illustrated in appendix D.8. The total anchor weight should be 27 kg and the rope should be approximately 35 metres long. The breaking strength of the rope should be at least 32 kN and the short anchor chain should be 8 metres long with 8 mm thickness. NBS also states that if the vessel use two anchors they may be to thirds of the estimated weight. The two anchors were therefore set to be 20 kg each. As the depth in the area is around 5 metres, it may be possible to use a shorter chain and rope. This will need approval from the Norwegian Maritime Authority.

Preliminary design was therefore as instructed by the NBS. Each Anchor storage room was estimated to require 0.35 m<sup>3</sup>. The total weight of the anchor system was set to be 30 kg, including the anchor, rope, winch and surrounding installations in the room. It may be necessary with additional installations to a conventional anchor system as it will need to operate autonomously. This will need further investigations and input from the autonomous system designer.

30 kg luggage was added to the design loading condition. This was based on requirements set in the NBS. As loading condition two, including nine people and three wheelchairs (with people in them) were the current design condition, it was added to this one. It was assumed that it would be sufficient space for the luggage, and it was therefore not included in any of the area and volume calculations. The new design load was then 1710 kg. This was added in the SBS D template and would be implemented in the 3D model later to ensure that the stability was intact. As this new design load is high compared to the other relevant loading conditions, the draught measurements may no longer be necessary. It was considered unlikely that this design load would be reached and it was therefore concluded to remove the draught measuring from the design as it would imply an increase in cost with little actual benefit. The number of passengers would be limiting before the weight and the registration system was therefore more important. It would be relevant at a later stage to investigate more accurately if the benefits could make up for the cost.

Finally, the weight of the hull, main deck and superstructure were adjusted once detailed information became available. This was found by adding plate thickness and material density to the relevant layers in the Delftship 3D model. In addition, the weight of the two ladders on the outside of the hull and the strength elements were added to the hull weight. These were found through weight estimations done in a separate tab in SBS D template named “Strength elements”. The estimations will be described in more detail in section 8.1. The weight of the ladder was estimated to be 2 kg, based on comparable products available on the market.

## 7.5 Initial Arrangement Below Deck

The initial arrangement below deck was determined through sketches, and discussions based on these. The placement of the cooling system and battery rooms were already set when updating the SBSB template. These were located at the centre of the vessel. Earlier sketches, made before the PBES battery modules were included, show that the initial plan was to use two battery rooms separated in the longitudinal direction. This is illustrated in the first sketch in appendix D.9. The arrangement was infeasible for the PBES modules as they were too wide. The floor plan in the room would in reality be smaller than illustrated in the sketches as the hull narrows with increasing depth. The room would then need to be very large in the longitudinal direction. The chosen arrangement was also beneficial as it enabled the cooling system to be placed in the centre, maintaining the symmetry of the arrangement. Using the initial setup, this would not have been possible. A sketch of the arrangement as determined at this stage is presented in appendix D.9, sketch number two. It should be noted that the location of bulkheads will be slightly altered when the arrangement drawings set the final arrangement on board. This is because the bulkheads need to be placed on the frames and not in between them. This was not accounted for when making this initial arrangement.

Further, the bilge pumps needed to be placed close to the rooms they were to pump. They should also be placed close to the hull to ensure short routes for the water being pumped. The final arrangement is illustrated in the last sketch found in appendix D.9. The emergency pump is placed on the opposite side of the vessel to the regular pump to secure the best possible redundancy. The anchors were placed near each bow, one on each side to maintain the symmetry. These rooms may need to increase in size once more detailed information becomes available. For this study, they were assumed to be sufficient as no detailed design of the anchor system were set. The hydraulic generator rooms and the fire extinguishing system rooms were placed on each side of the thruster rooms. This place the hydraulic generator close to the cylinders it will be connected to. To secure symmetry, they were placed diagonally to each other on each side of the vessel. The thruster room is placed along the centre line. It was made as long as possible to ensure easy access for maintenance and inspections. At the two bows of the vessel, a void was placed to secure the on-board equipment in case of a front collision. The

remaining free space was set to be storage space for the extra life jackets. No weight was included in this room as the weight of the life jackets were included with the rest of the life saving appliances on deck. As they were placed symmetrically, this would not affect the stability results significantly. The size of the rooms in the sketch are not according to scale. The final size of the rooms were determined using information from the SBSD template. The resulting arrangement on the ferry is illustrated in figure 45. This is an illustration from Delftship after the arrangement was implemented in the hull model. Further, the detailed weight of the hull, superstructure and strength elements were to be determined and implemented in Delftship, together with all other weight on the vessel. This would be done to verify the arrangement using strength- and stability calculations.

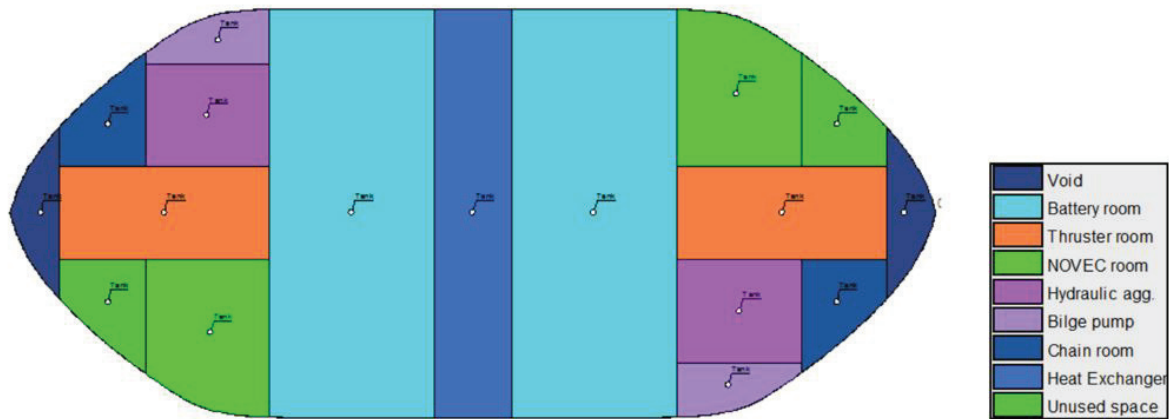

Figure 45: Resulting arrangement of the rooms below deck, figure from Delftship



## 8 Verification of Design

This chapter presents the evaluations used to determine the final design. It will discuss the stability- and strength calculations, the resistance calculations, the construction of technical drawings and the life cycle cost calculations.

### 8.1 Assessment of the Stability and Strength

To calculate the weight of the hull structure, all structural details were decided. To find the correct plate thicknesses and scantlings, simplified strength requirements from the NBS were utilized. The requirements for a vessel with a LOA of 9 m was found by interpolating between the values for a LOA of 8 and 15 m. The calculations can be seen in appendix E.1.

Plate thicknesses use for the plates in the bottom, deck, side, bulwark and superstructure can be seen in table 19. As these thicknesses are not standard for plates, the thickness used to calculate the weight of the hull structure was rounded up to 5 mm. The thicknesses and the density of aluminium was used as input for the different layers in the Delftship model, where the weight was calculated.

Table 19: Plate thickness for elements in the structure

| Plate type     | Thickness |
|----------------|-----------|
| Bottom         | 4.9 mm    |
| Deck           | 4.3 mm    |
| Side           | 4.3 mm    |
| Bulwark        | 4.3 mm    |
| Superstructure | 3.3 mm    |

To decide what structural elements to use, a cross section of the vessel was drawn up. The cross section can be seen in figure 46. A longitudinal bottom girder was placed in the bottom. The girder is a T-beam. Along with the girder, a knee plate was included, connecting it to the frame of the vessel. The frame stretches along the whole inside of the hull, up to the deckline. In the deck, there are five deck beams and two knee plates that connects the outer beams to the frame. The knee plates help avoid having sharp corners. Forces will gather in corners and theoretically result in an infinite stress at this point. This will lead to fatigue. The deck beams are T-beams, and stretch the whole length of the vessel. The dimensions of the different elements are given in figure 47.

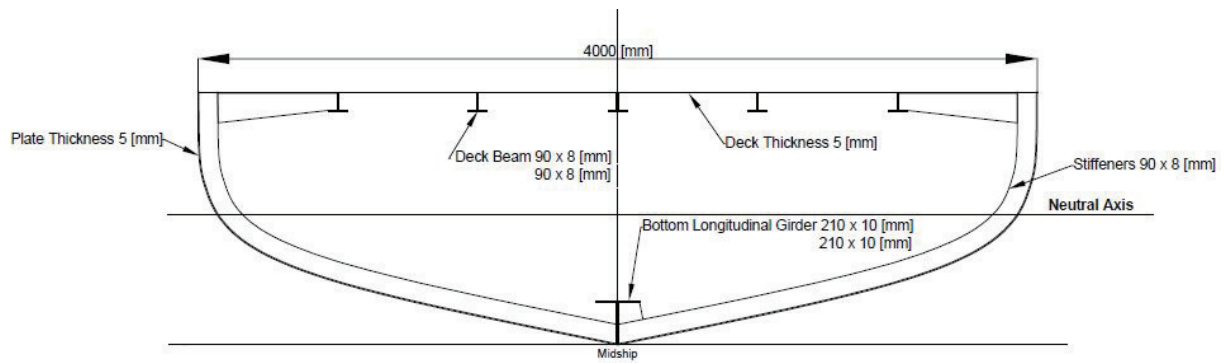
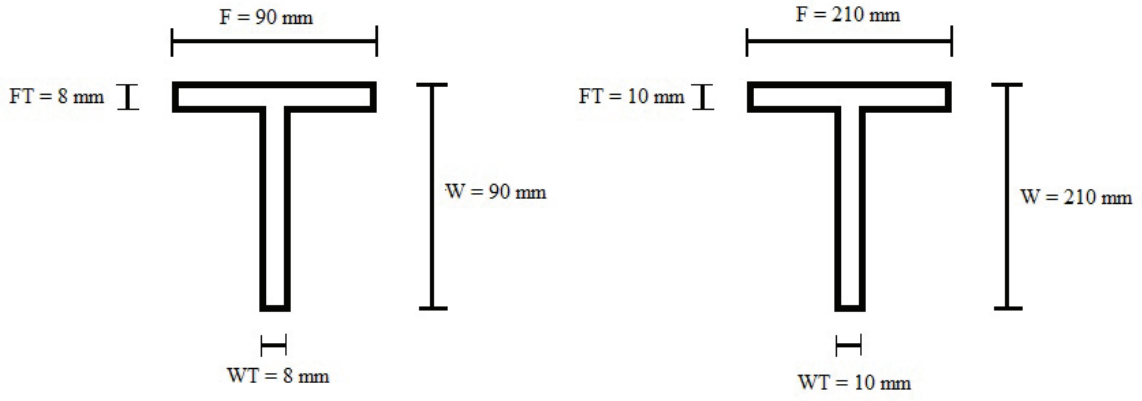

Figure 46: Illustration of cross section with structural elements





(a) Deck beam

(b) Bottom Longitudinal Girder

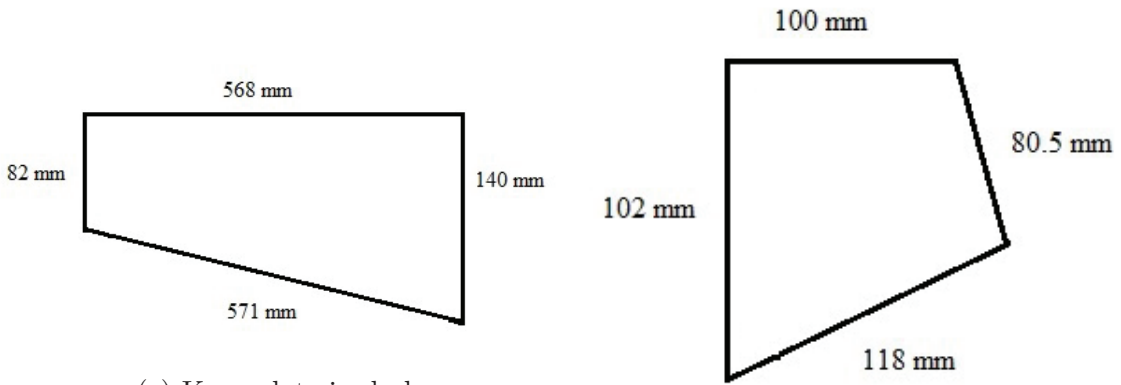

(c) Knee plate in deck

(d) Knee plate in bottom

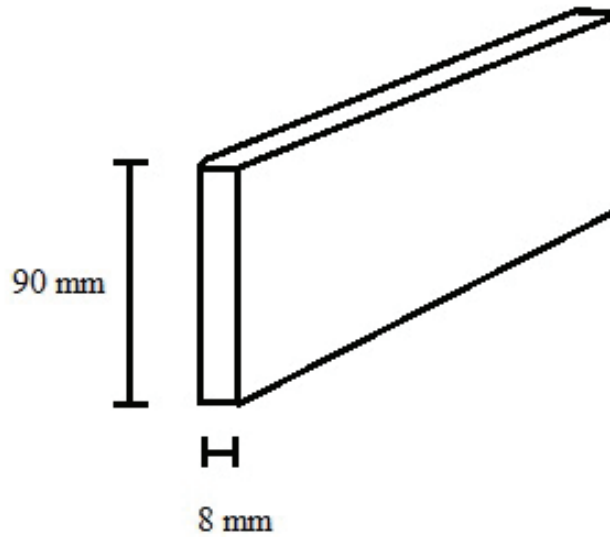

(e) Frame height and thickness

Figure 47: Illustration of structural elements

To find the required number of frames, the requirement for spacing between frames was used. The max spacing of 300 mm gives a total of 29 frames. It was assumed that there are knee plates for every frame, which sums up to 29 knee plates in the bottom and 58 knee plates in the deck. When the sizes and number of structural elements were set, an estimate for the weight of these were calculated. The weight of the hull structure and structural elements are all listed in the weight estimate in the SBSB template.

To do stability and strength calculations in Delftship, all weights had to be added to the 3D model of the vessel. First, all lightweights were added to the weight list available in Delftship. The lightweight consists of the weight of the hull structure, and all equipment that is permanently on the vessel. The different weights were assigned their vertical centre of gravity, transverse centre of gravity and longitudinal centre of gravity. The area the weight is distributed over was also defined. In addition to the lightweight, the deadweight had to be added to the vessel. The deadweight was represents the different loading conditions for the vessels. Excluding the lightweight condition, 14 loading conditions were analyzed. An overview of these conditions can be seen in table 20. The design hydrostatics report of the vessel with the design load on board is found in appendix E.2. The design load equals loading condition 14 in the table.

Table 20: Description of loading conditions tested in stability analysis

| ID | Loading Condition                | Explanation  |
|----|----------------------------------|--|
| 1  | LC1                              | 12 persons and 12 bikes evenly distributed around the middle of the vessel.  |
| 2  | LC2                              | 9 persons and 3 wheelchairs evenly distributed around the middle of the vessel.  |
| 3  | LC3                              | 10 persons, 2 bikes, 1 wheelchair, 1 stroller and 1 dog evenly distributed around the middle of the vessel.  |
| 4  | LC4                              | 10 persons, 5 bikes, 1 wheelchair and 1 stroller evenly distributed around the middle of the vessel.   |
| 5  | LC5                              | 12 persons evenly distributed around the middle of the vessel  |
| 6  | 30 kg luggage per passenger      | Same as loading condition number 5, but with 30 kg luggage per person.   |
| 7  | All passengers on starboard side | 12 persons placed towards the starboard side of the vessel.  |
| 8  | All passengers in aft            | 12 persons placed towards the aft of the vessel, condition to test trim of vessel.   |
| 9  | 3 wheelchairs in aft             | 3 wheelchairs placed towards the aft of the vessel, condition to test trim of vessel.  |
| 10 | 3 wheelchairs on starboard side  | 3 wheelchairs placed towards the starboard side of the vessel.   |
| 11 | 5 wheelchairs in aft             | 5 wheelchairs placed towards the aft of the vessel, condition to test trim of the vessel.  |
| 12 | 10 cm snow on roof               | 10 cm wet snow on the roof of the vessel, no passengers on board.  |
| 13 | 50 cm snow on roof               | 50 cm wet snow on the roof of the vessel, no passengers on board.  |
| 14 | Loading capacity, design load    | Same as loading condition 2, but all passengers have 30 kg luggage. This represents the max loading capacity for the vessel, and this weight should not be passed. |

A stability analysis was performed for all the loading conditions. It checks different requirements for a set criteria. There are no criteria in Delftship that fits the case in the study, therefore the IMO criteria for passenger vessels were chosen. With these criteria the initial stability at different heeling angles, initial metacentric height and severe wind and rolling are checked in the analysis. It may also check of what happens in the case of passenger crowding. As this was checked in loading condition 7 to 11, it was not calculated using the criteria. The criteria set by IMO are stricter than the requirements for stability set in the NBS. As the vessel is to be autonomous, the stability should be

better than what is required in the NBS. The IMO criteria were therefore used regardless to ensure a high level of safety. A stability report was generated, and showed that non of the loading conditions fulfilled the requirements. The specific criterion that non of the conditions fulfilled was the dynamic stability requirement ( $\text{AreaA}/\text{AreaB}$ ). To improve the conditions for this criterion a permanent ballast of 0.75 tonnes was added. The design hydrostatics report of the vessel with ballast and the design load on board is found in appendix E.3. With the ballast, all but four conditions fulfilled the criterion. The four conditions that did not fulfill the criteria were; "all passengers on starboard side", "snow on ferry roof 50 cm", "three wheelchairs on starboard side" and "snow on ferry roof 10 cm". The complete stability reports can be seen in appendix F. A summary of the reports is found in appendix E.4

The conditions with snow on the roof should both be avoided. 50 cm wet snow on the roof fails on multiple stability criteria. To avoid the conditions all together, the roof was rounded. The snow should then slide of if the vessel heels. To make sure no snow builds up on the roof, heat cables were added to the design. The cables will require some electricity in the winter months, but will help with avoid the troublesome stability condition.

The two conditions where the passengers and the three wheelchairs move to the starboard side are not very likely, but could non the less occur. Passengers might see something on one side of the vessel, and move to get a better view. It should therefore be possible for them all to stand on the same side. For the wheelchairs, it is not recommended to have them all on the same side. The most natural placement for them is in the middle. A possibility is to mark the placement for wheelchairs on the main deck.

The criteria that are used in the analysis are as mentioned the IMO passenger ship criteria. For the wind criterion it uses a wind speed of 50.54 knots, and a wind pressure of 51.4 kg/m<sup>2</sup>. This is a wind speed of 26 m/s which is classified as a storm on the Beaufort scale (Met office, 2016). Storms like this will create very high seas, but is not common inland. As the ferry will be operating in a closed off area inland, this wind criterion is overdimensioned for this study. In the preceding project thesis, the wind conditions in the Trondheim area between 1997 and 2015 were investigated. The highest registered wind speed was 18.3 m/s, which is equivalent to a wind pressure of approximately 26 kg/m<sup>2</sup> (Havdal et al., 2016). This is half of the pressure in the wind the criterion set by IMO.

To verify that a lower wind criterion could be fulfilled, a new criterion was made where the wind speed used for the wind and rolling criteria was set to 18.5 m/s. This equals a wind pressure of 26.1 kg/m<sup>2</sup>. A summary of the resulting stability report can be seen in appendix E.4, the complete results are found in appendix F. With this criteria, all loading conditions fulfill the criteria, except condition 13. To be certain that the vessel does not violate the dynamic stability criterion, an operational limitation can be set. At large wind speeds the ferry operation will be stopped.

Loading condition 8,9 and 11 looks at the weight being distributed towards the aft of the vessel. If all passengers place themselves in the aft, it causes a trim of 0.236 m. Three wheelchairs in the aft cause a trim of 0.114 m and five wheelchairs in the aft cause a trim of 0.108 m. This trim should be avoided as it affects the vessels resistance and the passenger comfort. The passengers are naturally guided to the middle of the vessel as the seats will be placed here. For the wheelchairs it could, as mentioned, be smart to have placements marked on the deck of the vessel. This would guide the wheelchairs to a placement that is more advantageous for the stability of the vessel.

When the placements of the weights and the ballast had been verified, a longitudinal strength report was generated. The report can be seen in appendix F together with the stability results. The longitudinal strength analysis looks at the sectional area which represents the buoyancy along the hull, the weight distribution, and the resulting load distribution on the hull. Based on the load distribution, the shear forces and bending moments acting on the hull are calculated. The calculations were done for every loading condition. The moments and forces working on the hull were not high. The highest values were for loading condition 13. In this condition, the largest bending moment is a sagging moment of 0.686 tm. According to the DNV GLs rules for classification of ships, part 3 chapter 2, the maximum sagging moment allowed for the vessel is 3.16 tm at the middle of the vessel (DNV GL, 2012). Thus, the vessel were within these requirements. Moment curves made based on the DNV GL rules can be seen in appendix E.5.

For the vessels' loading capacity, represented in loading condition 14, the resulting load distribution can be seen in figure 48. The weight peaks in the middle where the batteries are placed. This results in a positive load downwards on the vessel, as the weight is larger than the buoyancy. Towards the ends of the vessel, the weight is smaller causing two

negative loads upwards, where the buoyancy is larger than the weight. The resulting load distribution causes bending moments as shown in figure 49. The negative loads cause hogging moments, while the positive load cause a sagging moment. In total, the hogging moments here are larger than the sagging moment on the vessel. The largest moments act approximately half way between the centreline and the bow or aft. This is a hogging moment of approximately 0.245 tm. The moment curves based on the DNV GL rules show that the hogging moment allowed in this area is approximately 1.73 tm, and the vessel satisfied the requirements.

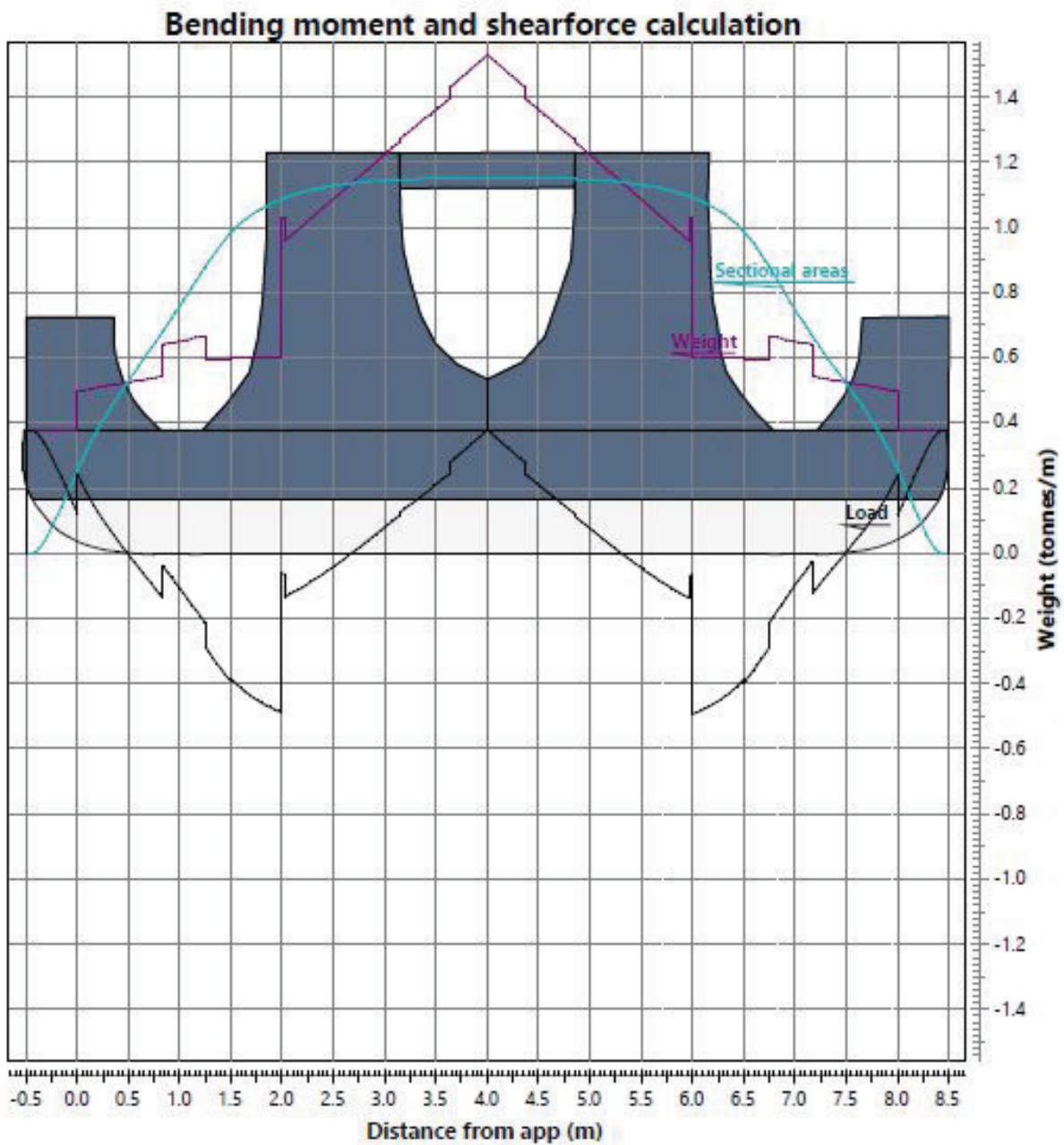

Figure 48: Plot of load- and weight distribution at design load

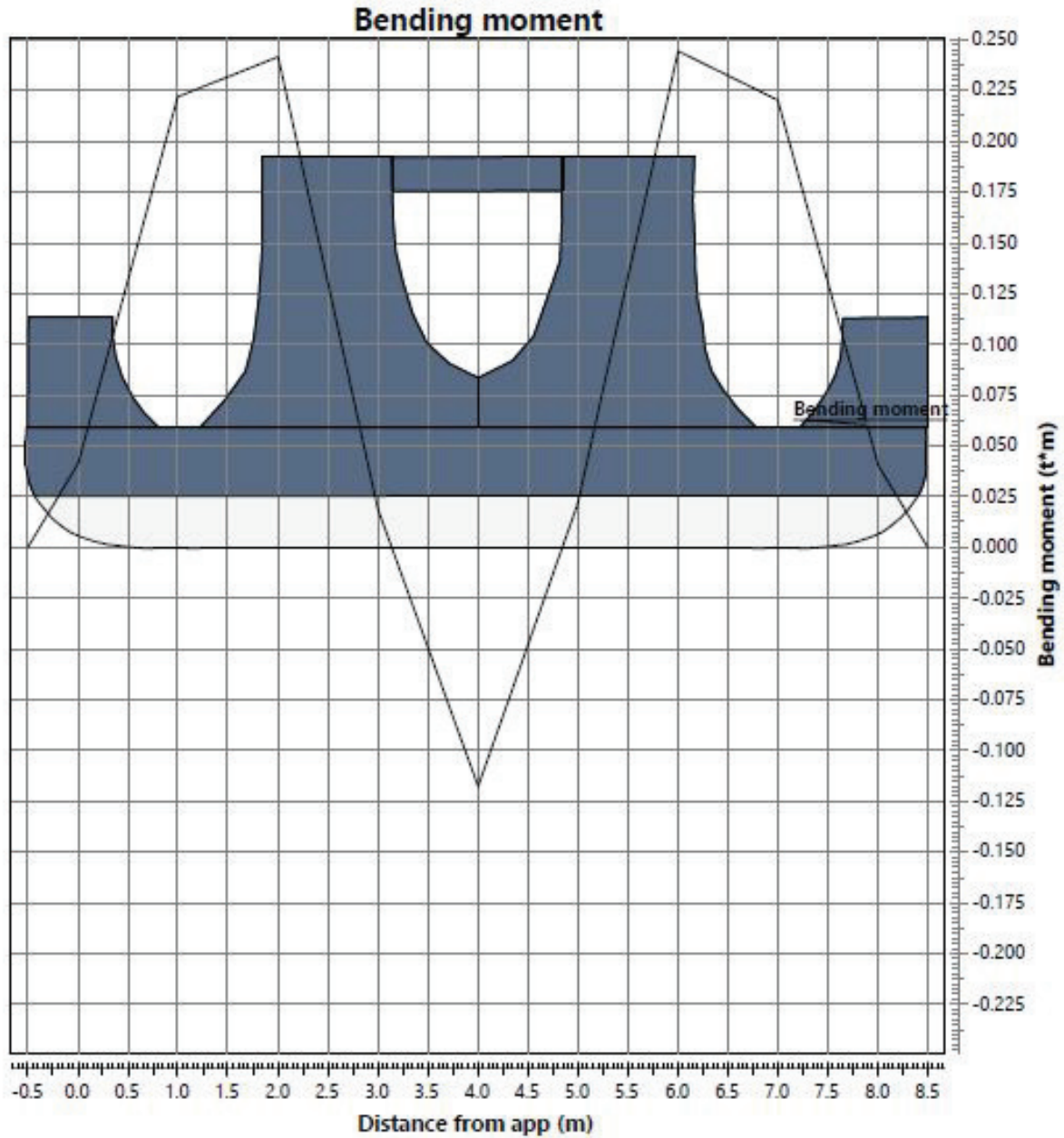

Figure 49: Plot of bending moment at design load

As an extra verification of the structural strength, the section modulus for the cross section of the midship was calculated. The calculations were based on figure 46 and a moment equivalent of the one in loading condition 13. The calculations can be seen in appendix E.6. To verify the results of the calculations, the DNV GL rules for classification of ships, part 3 chapter 2, was used to calculate the lower bound for the section modulus. Calculations of this lower bound, performed using the software Matlab, can be seen in appendix E.7. Results from the strength calculations are presented in table 21.

Table 21: Summary of results from the strength calculations

|                       |                    |             |
|-----------------------|--------------------|-------------|
| Z                     | [mm <sup>3</sup> ] | 135723959.1 |
| Z                     | [cm <sup>3</sup> ] | 135723.9591 |
| M                     | [tm]               | 0.686       |
| M                     | [Nm]               | 6729.66     |
| M                     | [Nmm]              | 6729660     |
| Z DNV GL              | [cm <sup>3</sup> ] | 2795.1      |
| $\sigma$              | [MPa]              | 0.05        |
| Yield stress          | [MPa]              | 170         |
| Requirement satisfied |                    | OK          |

The results show that the stress is very low, only 0.05 MPa. The section modulus is also well within the requirements from DNV GL. There might be some source of error in the use of the DNV GL rules, as they are for vessels under 100 m, and thus more suited for vessels somewhat larger than the ferry in this study.

## 8.2 Assessment of Resistance

To verify the choice battery capacity, resistance calculations were performed. Based on these calculations, the necessary power to reach the max speed of 5 knots was found. To calculate the resistance the computer program ShipX, developed by Marintek (SintefOcean), was used. In order to perform the calculations, a hull geometry was imported into ShipX. The hull geometry could be defined in ShipX, but importing from an external source it is more efficient. In this study, the hull geometry was created using the 3D model from Delftship. Autocad was used to make small corrections to the lines exported from Delftship.

When the hull geometry was imported, wave resistance calculations were performed for the design draught of the vessel, at 0.515 m. The wave resistance was calculated using a ShipX plugin called Waveres. ShipX generates reports with the results of the calculations, these can be seen in appendix E.8. The reports gave values for the wave resistance coefficient, the residual resistance coefficient for two different form factors, and the friction resistance coefficient. All the coefficients were given for different speeds between 2.9 and 6.2 knots.

Based on the results from ShipX, the total resistance was calculated. The calculations can be seen in appendix E.9. The total resistance for the design draught are represented



in figure 50. At the max speed 5 knots, the total resistance is 2000 N. Based on this the effective towing power,  $P_E$  was calculated to be 5100 W. This is the necessary power for the vessel to be towed at 5 knots.

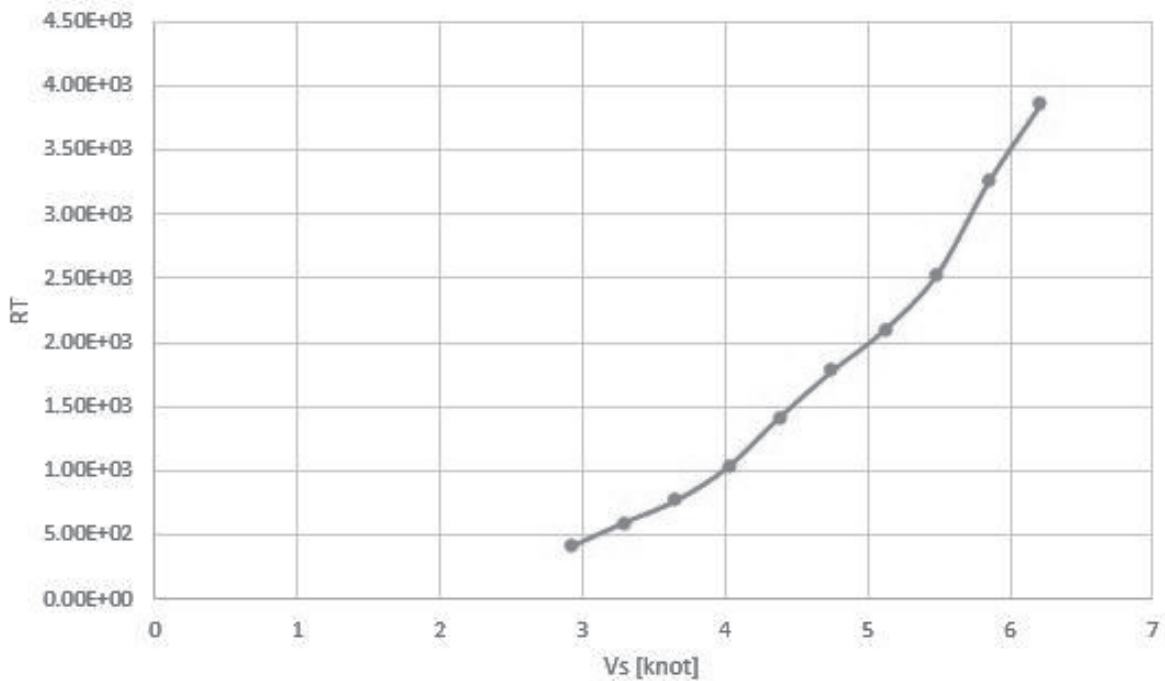

Figure 50: Total resistance for the vessel according to speed

In this study the total efficiency is set to 0.5. This might be a bit too low for the propulsion system used in this study, but was thought to give a good estimate of the power needed for the vessel. With this efficiency, the necessary brake power for the vessel was calculated to be 10.2 kW. The two battery modules from PBES have a power of 30 kW, and energy content of 26 kWh each. The duration of one trip with the ferry is estimated to be approximately 2 minutes. The ferry will then use 0.34 kWh (10.2 kW for 2 minutes) per trip. It should then be able to do 76 trips before one of the battery modules is completely discharged. Based on these results, the two battery modules from PBES should be more than enough for the operation of the ferry and all the other systems that need electricity.

The azimuth pod that was used for estimates in this study for the ferry has an efficiency of 92%. At max input 10870 W, it delivers 10 000 W output (Aquamot, 2017). This should be sufficient to give enough thrust to reach the maximum speed of 5 knots. It should also be able to account for the currents from the side in the channel.

At the operational speed of 4 knots, the required input power from the batteries is 4200 W. With this power consumption, the ferry can operate for approximately 6.2 hours per battery module. For comparison, with the previously chosen Torqueedo batteries, running with this power demand would give an operating time of 2.5 hours without charging. The operational profile for the vessel shows that in high season, the ferry can have a period of up to eight hours of continuous operation. With the Torqueedo batteries the ferry would have to take charging brakes to be able to get through the day. With updated values for the required power, the operational profile was updated. With new values there were an increase in electricity per year from 10 000 to 17 000 kWh. The new version of the operational profile can be seen in appendix F.

### 8.3 Technical Drawings

Technical drawings of the vessel design have different ranges of application, depending on the type of drawing. In this study, they were primarily used to illustrate the size and location of systems and areas on board. System drawings were made to illustrate how the system parts are connected. They also give insight to what might be important to achieve the best possible functionality. The different drawings were made using the Autodesk software AutoCAD. All technical drawings are found in appendix F. The line drawings of the vessel were imported from Delftship, defining the vessel shape. Relevant aspects related to the drawings were based on guidance from the book “Teknisk Tegning” (Norges Standardiseringsforbund, 1993). This includes among other things the title block, frames, scaling and symbols for valves. This chapter discusses the aspects relevant in the production of the drawings, and briefly discuss relevant information from each of them.

Before making the final drawings of the ferry, the freeboard requirement from the NBS was calculated to ensure that the design is according to requirements. Weight displacement of 7.6 tonnes imply freeboard requirement of 0.68 m. With design draught 0.515 m, this requirement is met. The NBS also requires the freeboard at the two bows to be 1.2 times the freeboard requirement. It was assumed that the ramp and other structure in the bow area would be water proof when the ramp is closed. The requirement was thus considered to be fulfilled.

The drawings produced for this study included general arrangement, lines plan, midship section drawing, system schema drawings, detail drawings and one-line diagram. The aft- and front perpendiculars (AP and FP) were defined 74 mm from the two bows, through the construction water line's foremost and hindmost point. These were both based on the definition of the front perpendicular, as the vessel in practice will operate with two bows. The first step in producing the drawings was to set the frame spacing, as this is used for reference in the drawings. The arrangement of the vessel needs to be designed according to the frames, as mentioned when setting the initial arrangement. Therefore, the bulkheads defined in the Delftship 3D model were redefined when making the arrangement drawings. It would be important to ensure that the necessary space for each system was still maintained. The frame space was set to be 300 millimetres. The NBS sets this as the maximum allowed spacing. The spacing for the longitudinal stiffeners was reduced to 500 mm. The NBS does not define requirements for this strength element and it was therefore assumed based on similar small passenger vessels. This was a change from the cross section used for the strength calculations. It was done to avoid buckling of the main deck. Frame number zero was set to be placed in the middle of the vessel, between AP and FP. Positive frame numbers were then found moving towards FP and negative frame numbers moving towards AP. Another possibility would have been to place frame number zero at AP. This is the widespread practice for other ships but since the vessel is symmetric, it seemed more practical to place it in the middle. It is also common on ferries with a symmetric layout such as in this study.

### **8.3.1 General Arrangement**

The general arrangement illustrates the location of bulk heads and decks, as well as provide information on the placement of rooms and main outfitting. Positions and distances are defined, which may be used further in more detailed drawings. The general arrangement for the ferry can be found in appendix F. The division of space into rooms were based on the arrangement set in Delftship. Minor changes were made to ensure that the bulkheads were placed on frames. For instance, the bulkhead separating the battery room from the thruster room was moved 0.175 m into the battery room. The bow was also changed to fit the ramp better, as discussed in section 7.2.

In addition, the thruster-, fire extinguishing- and hydraulic generator room was merged into one large room. The larger combined space will make inspection and maintenance simpler as there is more space for people to move around and only one hatch is required in the main deck, instead of three. It will also make welding work less complicated and require less materials. No rules or regulations requires this equipment to be in a separate room. One of the bilge pumps and the emergency bilge pump was now located in the same room. As they will be connected to different battery modules, it should not pose any problems. Further, the battery rooms were merged with the cooling system room. Two separate cooling systems were installed, one in each battery room. The size of the cooling system was based strictly on the design team's assumptions since no detailed information on such systems were available. It may therefore be possible that the copper/nickel tubes on the outside of the hull will be shorter or longer. This will need further detailing before specific equipment is purchased later in the project. It was considered part of the further work in this study.

As previously mentioned, the ferry was to be equipped with twelve foldable chairs. The chairs were organized with six seats on each long side of the vessel. To illustrate that the chairs are foldable, a line was drawn through each seat as in figure 51. The v- shape found underneath each chair is the bicycle rack. It was designed to have one slot in each direction to make it easy to use regardless of which way the ferry is moving. These racks will be most important when there are many people on the ferry, as they help organize the passengers in an orderly manner. It was assumed that the person owning the bicycle would stand next to it during transit as the trip is only one minute. If there are few passengers on board, they may easily sit down on the seat next to their bicycle.

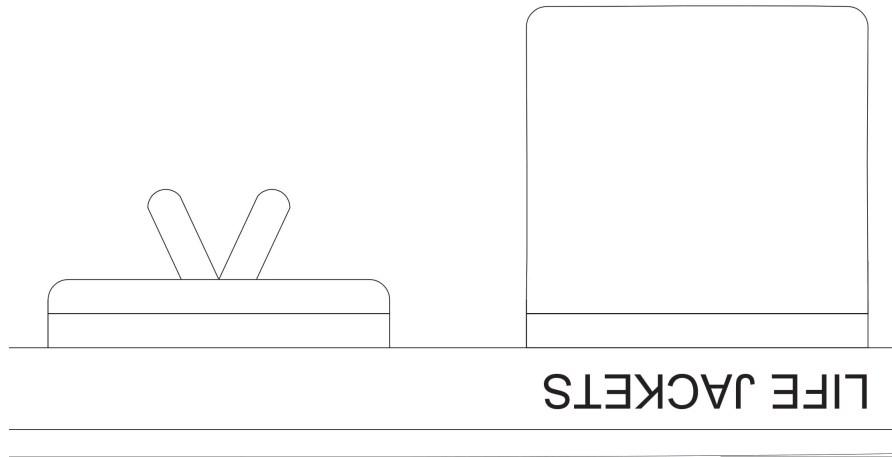

Figure 51: Illustration of foldable chair

Further, safety equipment including fire extinguishers, emergency stop button, life jackets, life buoy and emergency ladder was included in the drawing. It is required that life jackets are available for all passenger groups using the ferry. In this case, wheelchair users and children set limitations to their location. It was concluded that the best place to store life jackets were in a box integrated in the chairs on board. The back rest of the chairs would be made up from a box that may be opened in case life jackets are required. This box induced changes to the superstructure design. The fence on the middle of the superstructure was replaced by a wall to support the box. The box is divided into two halves to make it easy to open. An easily available handle would be used to open the box. Each box was designed to be 4.2 m long and 0.5 m high. Inner thickness of the box was set to be 12 cm, giving space for seven life jackets per box. One box at each side of the vessels makes room for in total 14 life jackets. It was assumed to be six adult life jackets per box and one for children. The remaining would be placed below deck near the bow. It was assumed that this would be according to rules as more than enough life jackets are placed available to all passengers. This solution would free up space from the deck as no additional storage space on deck would be necessary. Still, the boxes would make the seats take up 12 cm more out into the room than first anticipated.

The life buoy was placed on the fence to secure it being in reach of all passengers. This would also make sure that it is visible from the outside of the ferry, giving passengers a feeling of safety before entering the ferry. It would also make it easy for anyone to describe to a child on board that they need the life buoy, if they had fallen into the water.

In addition, it was considered an aesthetic feature to have the life buoy visible from the outside as it gives a maritime feel to the design. The emergency ladder was placed according to regulations in the NBS. It requires the bottom step to be located at least 300 mm below the waterline in the light loading condition. To achieve this, the ladder is foldable. It must also be permanently mounted to the hull. It was placed close to the fence to make it easier to get on board. The two fire extinguishers were placed near the fence, on the opposite side of the vessel to where the life buoy was placed. The emergency stop buttons were placed on the wall of the long side of the vessel, one at starboard and one at port side, next to the seats and close to the fire extinguishers. This symmetric placement of the buttons ensures that they are easily available to all passengers on board. It was important to place the buttons in the correct height so that children and wheelchair users are able to reach them if alone on the ferry. The ideal height was one meter above the deck (Sintef Byggforsk, 2006). The buttons were designed to have a cover to secure that no one accidentally press it. Above the stop button, the communication panel was placed. These also needed to be easily available to all passengers in case they needed contact with the land base.

### **8.3.2 Loading Condition Examples**

To verify that the arrangement will be functional during operation, relevant loading conditions were tested in the loading condition arrangement drawings in AutoCad. All passengers and equipment are according to scale. The space for the passenger groups reserved was the same used in the SBSB template and area investigations in section 6.8. Figure 52 includes all possible passenger groups considered in the study. As apparent from the figure, all passengers will have sufficient space on board.

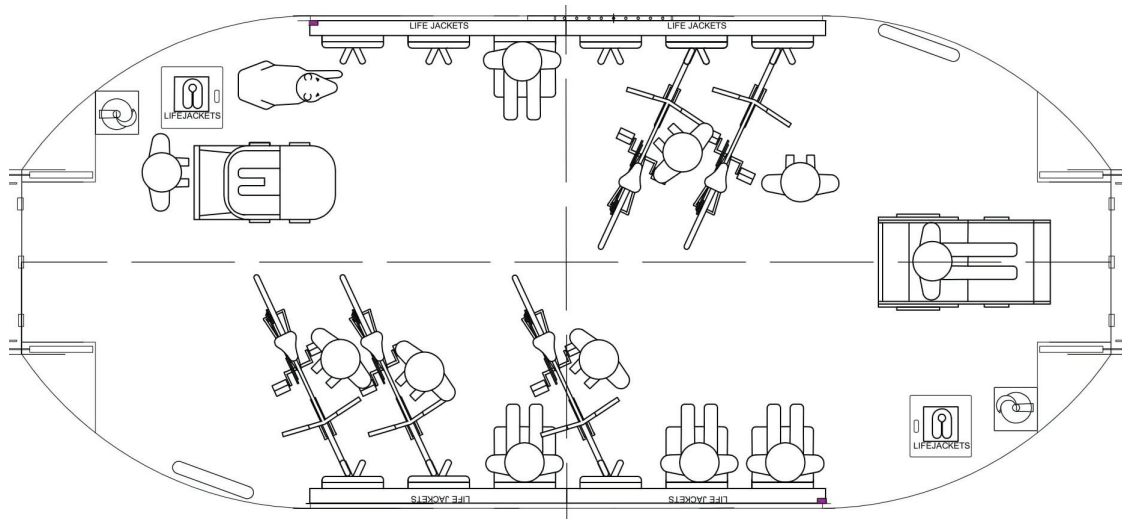

Figure 52: Illustration of all passenger groups on board

Figure 53 verified that twelve passengers could bring their bicycle on board. Another scenario was set to test if this would be acceptable if the passengers did not use the bicycle racks. As seen in figure 54, twelve bicycles would still fit on board, despite one being left out in the illustration. The figure also shows that leaving out one bicycle would make enough room for a wheelchair on board. It would seem from the figure that there is not room to evacuate the ferry in this case. As the bicycles are held by the passengers they will easily be able to push them to the side and evacuate if necessary. It was therefore assumed safe to set specific restrictions only to the number of wheelchairs on board. The number of bicycles would not be a problem. Figure 55 illustrate that there should be sufficient space on board even if only some of the passengers choose to use the bicycle rack and some place their bicycles randomly.

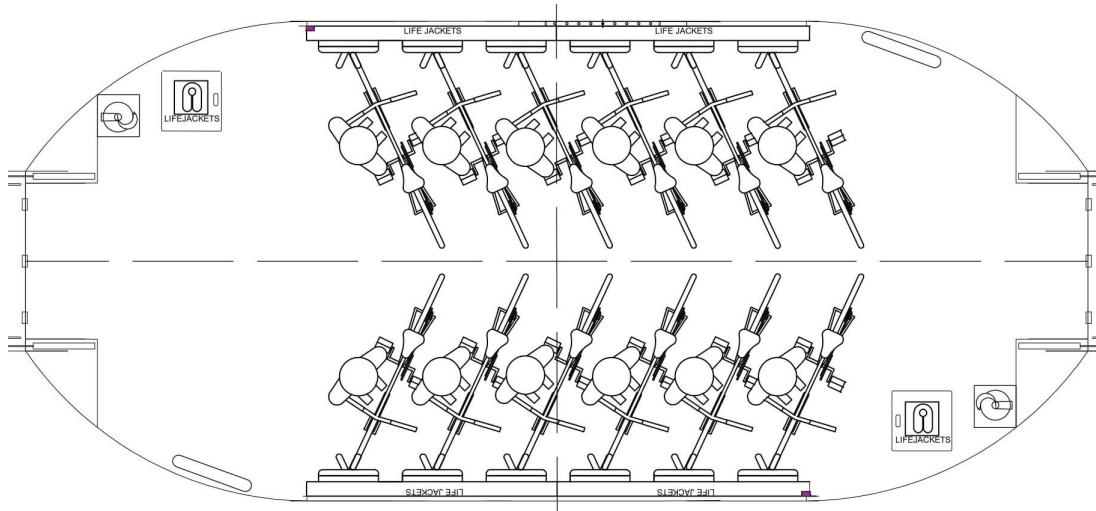

Figure 53: Illustration of 12 bicycles placed in the bicycle racks

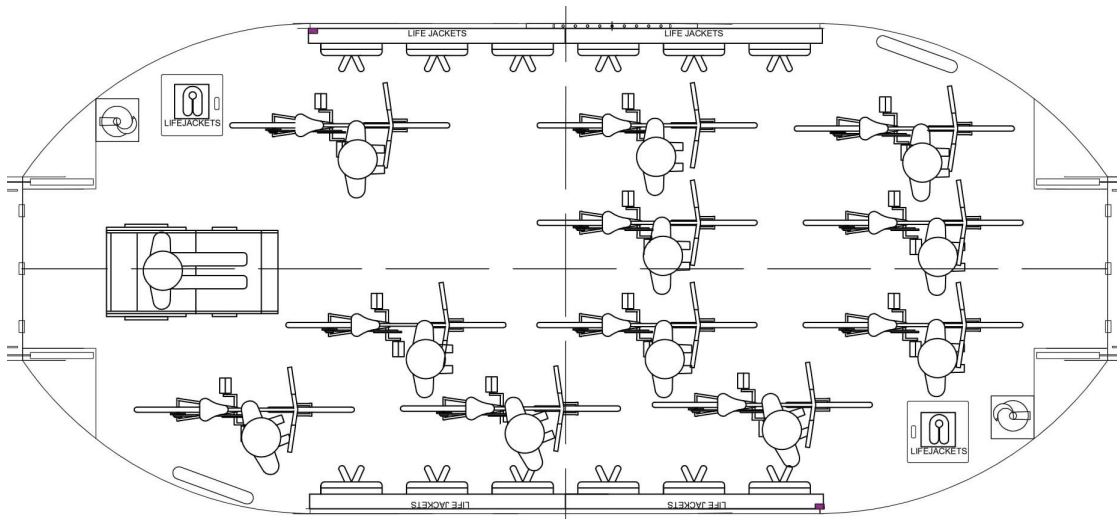

Figure 54: Illustration of 11 bicycles not in bicycle racks, and one wheelchair

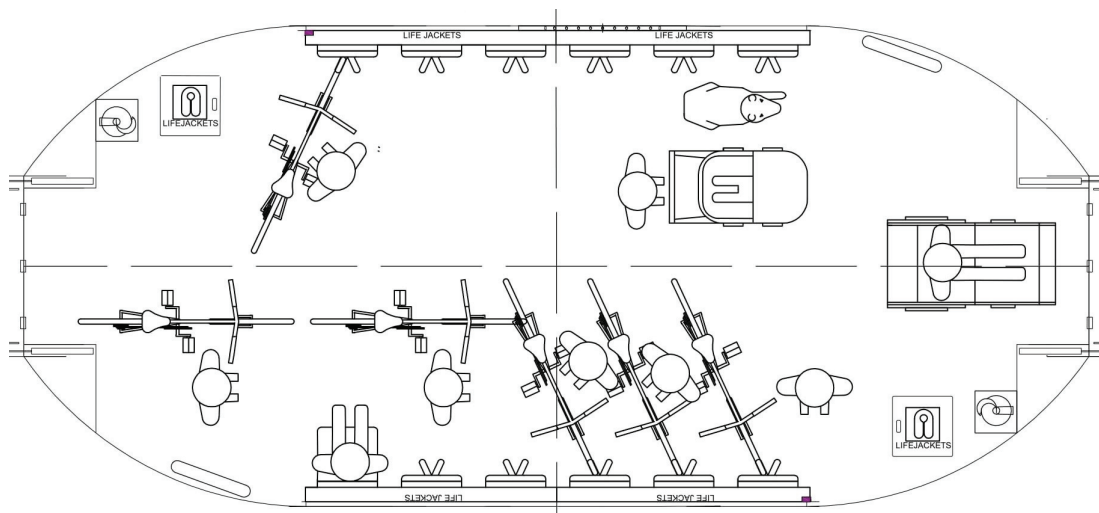

Figure 55: Illustration of bicycles placed in an unorganized fashion



Finally, figure 56 verifies that the design load with 3 wheelchairs, 9 people and 12 units of luggage will fit onto the ferry with little difficulty. The conclusion from the testing was that the ferry had sufficient deck space for the passengers to not feel cramped when the ferry is in normal operation.

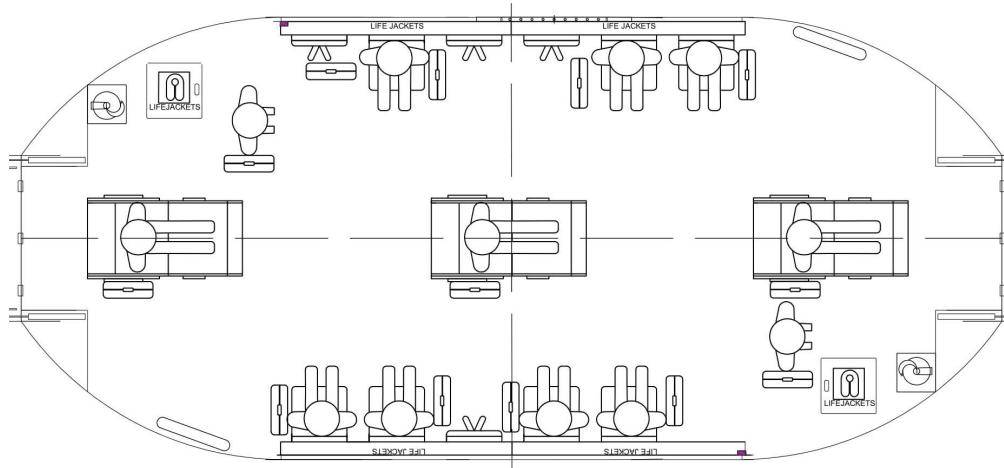

Figure 56: Illustration of design load case

### 8.3.3 Lines Plan

These drawings were not produced using AutoCAD, but imported directly from Delftship. A new modified hull model was made in Delftship to make the line drawings fit better to the new hull shape used in the arrangement drawings. These modifications were made on intuition, and the line drawings will therefore only give an indication of the actual preferred hull shape. Further detailing of this will be required.

The line drawings, found in appendix F, illustrates the shape of the new flat-bow hull, set in the AutoCad model. As mentioned, they will not be 100% accurate to the arrangement drawings as they were made at a late stage in the process to secure that the line drawings had better correlation with the arrangement drawings. The drawings give the designer an idea of the curvature complexity and thus how challenging it will be to build it.

As the ferry is to be made from aluminium, the hull should be shaped using chines and not double curvature plates as this is expensive and difficult to do when using aluminium. The hull therefore needs to be modified by someone with expertise on aluminium hull building before production. Changes to the lines drawing were therefore expected to occur at a later stage, as double curvature was present in the hull currently.

### 8.3.4 Midship Section

Information on plate thickness, the location of strength elements, type of elements and knee plates is found in the midship section drawing. The structure of the vessel becomes apparent and it provides a basis for rough weight estimations. The drawing illustrates the knee plates, frame, longitudinal bottom stiffener and deck stiffeners. It is typically used as basis for other drawings and for classification of the vessel. It also provides rough information about the required welding. The thickness of plates, placement and number of strength elements were set according to requirements from the NBS. This was discussed in section 8.1. It was assumed that this drawing will be relevant for the Norwegian Maritime Authority if they are to approve the ferry for operation.

### 8.3.5 System Illustration Drawings

The system illustration drawings are presented below. These drawings provide the input of a system scheme combined with a more detailed arrangement drawing. They provide information on the functionality of the different systems on board the ferry, and how their different components are located in relation to each other. These drawings are not according to scale. The detailed piping and cabling may also differ from the ideal layout as this was not designed in detail in this study.

#### **Bilge System**

The bilge system on board consists of one pump in each battery room and one in each of the combined thruster/equipment – room. In addition, two emergency pumps were included, one in each thruster room. The bilge system drawing is seen in figure 57. The pumps were placed as low as possible in the room to secure early water detection. The pumps will push the water upwards and out through a valve in the hull. This valve was equipped with a non-return valve to make sure of no water intrusion in case the vessel heels and the valve is lowered under water.

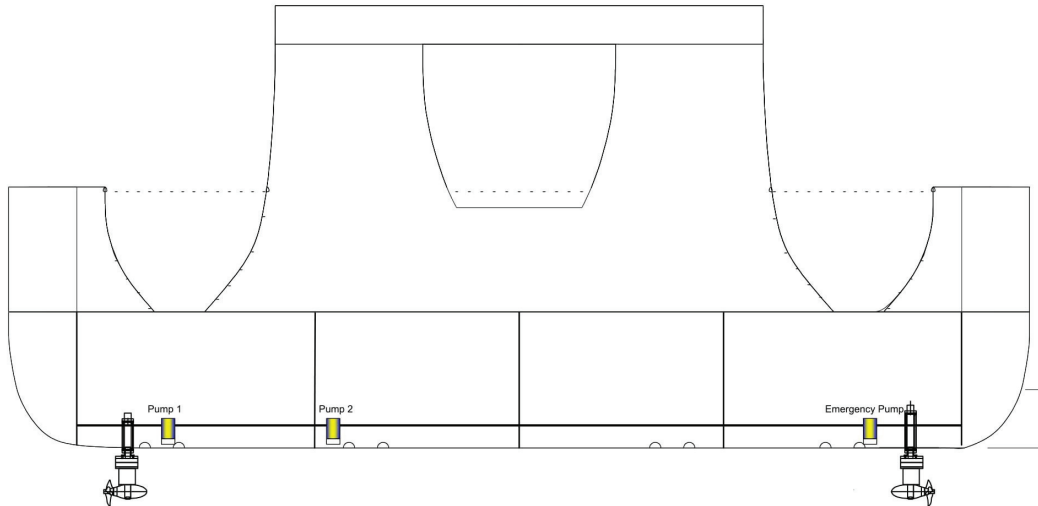

Figure 57: System illustration drawing of bilge system

### Firefighting System Below Deck

Fire detectors were included in all rooms below deck. These will be necessary to detect possible fires and alert the autonomous system to act. The surveillance central on land should also be connected to these detectors. The fire extinguishing system for the rooms below deck use Novec 1230 as extinguishing gas. The tank bottles containing the fluid were dimensioned according to the required amount of Novec. In section 7.4, it was estimated that three tanks of Novec would be necessary to secure the battery-, thruster and hydraulic generator room on one side of the vessel. As the thruster- and equipment rooms were now combined, the amount of Novec needed adjustments. The complete notes including new calculations are found in appendix D.7. Only two rooms needed fire extinguishing, indicating the need for two Novec tank bottles. The battery room was still  $6.4 \text{ m}^3$  after combining it with the cooling system. The volume was here estimated using tanks in the 3D model, giving a more accurate estimation than earlier. It was apparent that the previous estimation had been too high. The new thruster/equipment room was  $8.0 \text{ m}^3$ . As previously mentioned, the required amount of Novec was based on estimates from a previous project, provided by Nortronik. The Novec to volume ratio was  $1.45 \text{ kg/m}^3$  room. This indicated a need for 10 kg per battery room and 12 kg per thruster/equipment room, both numbers rounded up. The table of tank sizes indicate that both tanks should be 16 litres (Engebø, 2017). The 10 kg tank would have been sufficient, but the larger tank was considered a better solution as it enables the Novec amount to be increased at a later stage if necessary. The volume to weight ratio of the

tanks ( $0.75 \text{ kg/m}^3$ ) indicates a tank weight of 12 kg. The total weight of the Novec tanks were thus 22 kg in the battery room and 24 kg in the thruster/equipment room. This was an increase in the total weight of the Novec system. As the tanks are placed symmetrically on board and have relatively low weight, the stability should not be significantly affected. Two tanks were placed on each side of the vessel in the thruster/equipment room as there are no requirements to them being in separate rooms. One tank was reserved for each battery room, and one for each thruster/equipment room, in total four tank bottles. The system is illustrated in the system drawing, found in figure 58.

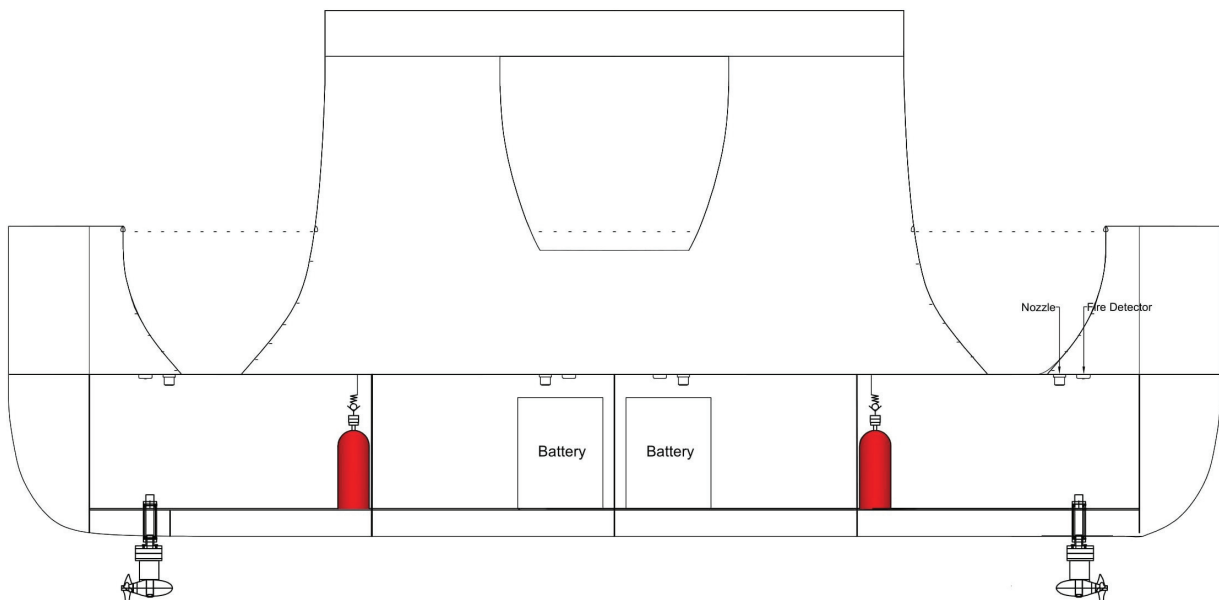

Figure 58: System illustration drawing of fire fighting system below deck

To secure short response time in case of fire, the tanks were placed as close as possible to the battery rooms. Fire detectors were placed in all rooms to detect possible fires. The detectors will alert the control unit that controls the system. A nozzle in the battery rooms, connected to the tank, will spread the Novec fluid into the room where it will transform into gas if the fire alarm is triggered. In the thruster/equipment room, the nozzle is placed in the middle of the room. All nozzles are placed in the ceiling to secure optimal spreading of the Novec. In addition, tubes to link the tanks and nozzles were

required. The Novec systems sets requirements for maintenance. The pressure of the tanks need inspection once a week and the nozzles need inspection once a month. In addition, an annual control is required by a certified company. It was therefore important that the tanks are easily accessible through the hatch in the main deck. There should also be a pressure sensor alerting the land base in case of error. Camera surveillance of the tanks is also a possibility. This will need to be discussed with the Norwegian Maritime Authority to confirm the solution before considering installing it. Therefore, it was assumed that the person responsible for the ferry operation will perform inspections once a week. As the Novec could be stored in temperatures down to zero degrees Celsius, as well as elevated temperatures, there is no need for cooling or heating in the storage room.

### **Battery Cooling System**

To maintain the prominent level of redundancy on board the ferry, two separate cooling systems were to be installed. Each battery module will have its own separate cooling system consisting of cobber-nickel tubes mounted underneath the hull. As the 3D model in Delftship had only one cooling system, the weight of the cooling system may differ slightly from that used in the stability- and strength calculations. The size in the drawing is, as mentioned, not according to scale as detailed information on the system was not available.

Each of the cooling systems would require its own circulation pump to move the cooling water through the pipes. Shut down valves and temperature regulating valves were also included in each system. The temperature regulating valves regulate the water flow to ensure the correct temperature of the cooling water. This ensures that the correct mixture of hot- and cold-water flow into the battery module. To secure the ferry and cooling system against corrosion, the cobber-nickel pipes and the aluminium hull had to be isolated from each other. The hull fitting would need to secure this in addition to being completely water tight. Supports were also included in the outside of the hull to ensure the pipe and hull do not touch each other. In addition, space was reserved for heaters in each battery room. It was uncertain whether the battery room could become too cold during the winter months. It was decided not to include the heater as PBES thought it would not be necessary (Plan B Energy Storage, 2017), but it will now be easy to install one if the need arises. Further investigations will be required to determine this.

### Ramp Mooring System

On each bow of the ferry, a notch was placed. When the ferry enters the dock, this notch is used for mooring. A smaller ramp on the dock, with a hook fitted for this notch, will be held over the notch by a spring. When the larger ramp located on board is lowered, it will press this small ramp into the notch, securing that the ferry is held in place. The ferry is then ready to be boarded by passengers as the entrance is open when the ramp is lowered. The mooring system drawing in figure 59 illustrates this procedure. The left part of drawing illustrates the ramp when mooring is activated. The right part illustrates the system when not in use. The square between the vessel and the dock is a fender.

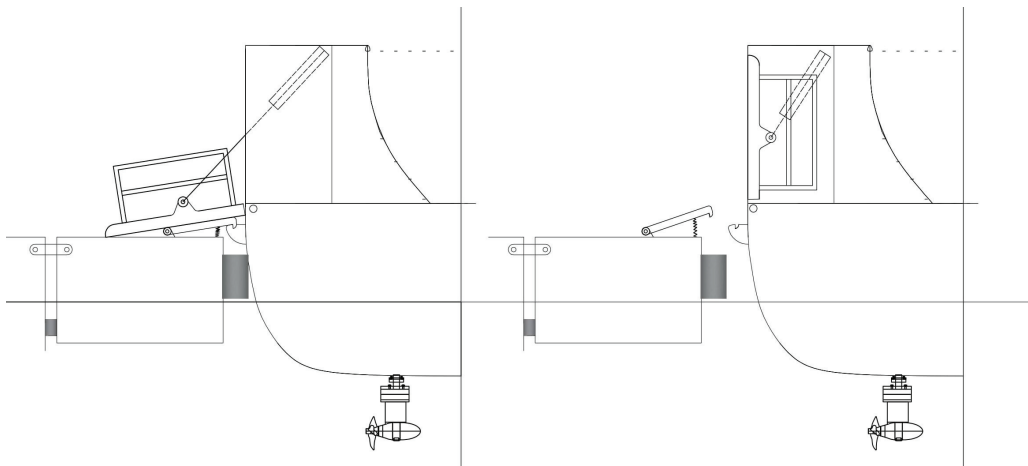

Figure 59: System illustration drawing of ramp mooring system

Hydraulic cylinders are to be used to move the ramp on the vessel, as well as keep it in place. The cylinders were placed inside closed boxes on deck to keep the passengers away from the moving cylinders, avoiding crushing hazard. The ramp itself was also equipped with a 40 cm high fence to keep passengers away from the hydraulics. It was made this low to make sure it does not take up space from the passenger lounge when the ramp is closed. The hydraulic generators below deck power the cylinders. Therefore, connections between the cylinders and the generators were necessary, though not included in the system drawing. To be able to maintain the force pressing down on the dock, the ramp could not be flexible to wave movements. As it is likely that waves would make the dock and the ferry heave with different frequency, measures were necessary to counteract these movements. To ensure absorption of the forces from the wave movements, the dock was split in two parts. These two parts are linked together using flexible hinges and shock absorbers in between the two modules. It would be a similar solution to articulated buses.

## Navigation Light System

The navigational light system was designed according to *The Regulation on Life-saving Appliances on Ships* (Lovdata, 2014) and includes a total of five lanterns. The top light is white and shines 360 degrees around the vessel. It is placed at the longitudinal centre of the vessel one meter higher than the other lanterns according to regulations. Further, there are four coloured side lights, two on port and two on starboard side. These shine 112,5 degrees around the vessel in either red or green. As the ferry does not turn, four navigational lights were necessary. Normally, only two side lights will be necessary. The system drawing of the system is found in figure 60. The coloured lights should be placed on the front half of the vessel. As this vessel do not turn, what is considered the front half of the vessel will switch according to which transit the ferry is taking. Therefore, the navigational lights need to shift between the two pairs. This shifting of the light may be controlled by the GPS registering the direction of movement. There were no height requirements for these lights. It was also considered relevant to include a new type of navigational light on board, indicating that the vessel is autonomous with no crew on board. This is used for instance by pilot boats to indicate their status. As no such light is currently available, it was not included in the system drawing. This needs to be discussed with the Norwegian Maritime Authority before building the vessel to secure their approval.

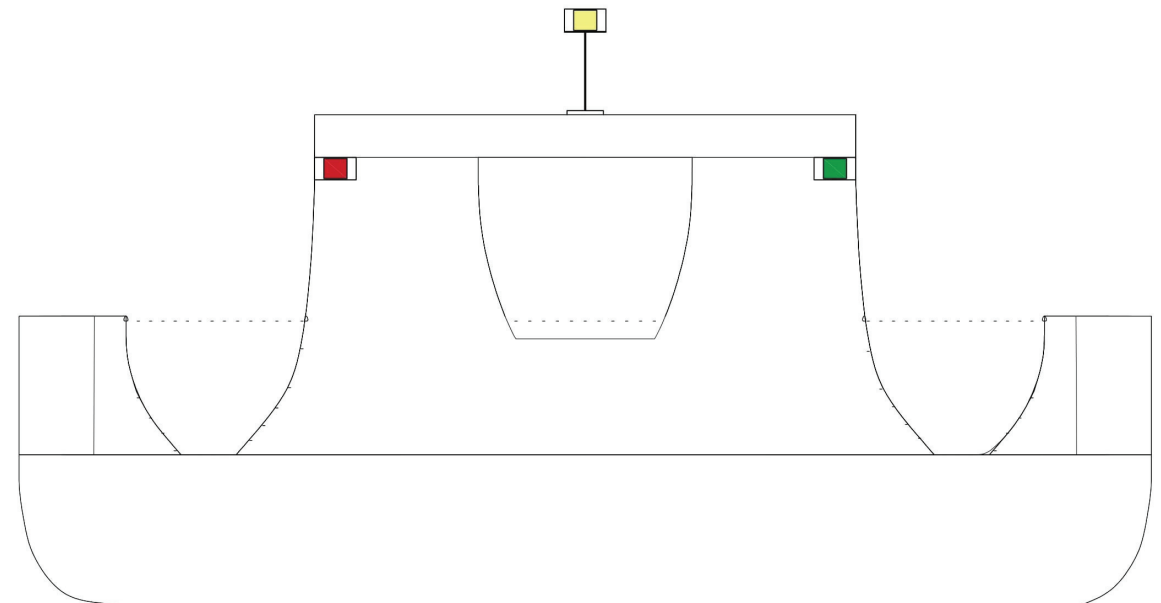

Figure 60: System illustration drawing of navigational light system

### 8.3.6 One-line Diagram

The one-line diagram, also called the electrical scheme, illustrates how the electrical components on board the ferry are connected to the main switchboard. The power is transferred from land, through the charger, to the two battery modules where it is stored. The main switch board is made up of the distributor and two DC/DC converters that secure the right voltage out from the distributor. One of the converters handle the heavy electronics such as propellers and the hydraulics. The other secures an even voltage on lighter equipment like the lanterns, safety equipment and bilge pumps. The converters will ensure a galvanic separation so that unwanted noise does not disrupt the signal to sensitive electronics (Eide, 2017). Further, the main switchboard transfers and distributes the power to all necessary system parts on the ferry. The autonomous components are connected to their own operations central controlling the propulsion of the ferry. These provide both the thrust and navigation. Regulators were placed on each thruster to regulate the voltage into the propeller.

### 8.3.7 Firefighting Scheme

This scheme is made using an example from Nortronik as inspiration. It illustrates how the Novec fire extinguishers are connected to the different rooms on board. It also displays how signals are transferred through the system. When the fire detectors detect a fire in for instance the battery room, it sends signals to the Novec control central. This is further connected to the autonomous system that controls the vessel. It will send a signal to the Novec control central to signalize the battery room to close the ventilation in the room, before signalling the Novec valves to release the Novec into the room. As discussed previously, the rooms in need of fire extinguishing has a nozzle mounted in the roof that sprays the Novec into the room when needed. It is apparent from the scheme that the system also requires Novec tanks, piping, valves on the tanks and tight fittings between the different rooms.



## 8.4 Calculation of Life Cycle Costs

To check the economic performance of the vessel, a life cycle cost (LCC) analysis was performed. Calculations were made to find the total LCC for the vessel, and for the combined system of both dock and vessel. The LCC was calculated as the sum of investment-, operation- and maintenance cost, subtracting the sales price. All costs are calculated as minimum, mean and maximum cost. The minimum cost is 5% lower than the mean cost, and the maximum cost is 5% higher. The complete LCC calculations can be seen in appendix E.10.

The investment costs consist of the building costs, material costs and component costs. The building cost of the vessel was based on four workers using three weeks to build the vessel. The labor costs are calculated as shown below.

|                          |
|--------------------------|
| Hourly wage              |
| + 4.5% Holiday pay       |
| + 12% Vacation pay       |
| + 14.1% Labor charge     |
| = Brutto Wage            |
| + 10% Personnel costs    |
| = Standard wage per hour |
| + Profit                 |
| = Labor cost per hour    |

The material cost was based on the weight of the hull and superstructure from Delftship, and a price per kilogram of aluminium. The component costs were based on components that were investigated in the SBSB template. All sources used to find costs are listed in the LCC appendix.

The operational costs were calculated as the present value of costs that occur during the operation of the vessel. This includes the cost of electricity and changing of batteries. The amount of electricity needed per day was based on the operational profile for the vessel, and was set to 17 000 kWh per year. The batteries from PBES have a lifetime of 10 years, and therefore has to be replaced during the vessels lifetime. It was assumed that the batteries would cost the same in 10 years, and a present value of the batteries was calculated.

To calculate the present value of the costs, the present value factor had to be calculated. The team here used the same present value factor as in the CBA, with lifetime 15 years and an interest rate of 5%.

The maintenance costs were calculated based on the vessel having maintenance performed four times a year while still in the water, and once a year while in a dry dock. Labour costs were calculated in the same way as for the building costs. Each maintenance operation was set to last eight hours, with one worker. For the maintenance in dry dock, renting the dock was assumed to represent an extra cost of NOK 1500 per hour. No loss of profit was considered as the vessel is to be free of charge. The sales value of the vessel was set to 80% of the investment cost. The present value was calculated and subtracted from the costs to find the total LCC. The resulting LCC can be seen in table 22.

Table 22: The LCC for the autonomous ferry

| <b>Cost</b>                                   | <b>Min</b> | <b>Mean</b> | <b>Max</b> |
|---|------------|-------------|------------|
| Investment cost                               | 969 929    | 1 020 978   | 1 072 027  |
| Present value operation cost                  | 237 834    | 250 351     | 262 869    |
| Present value maintenance cost                | 330 476    | 347 869     | 365 263    |
| Present value of sales value                  | 373 242    | 392 886     | 412 531    |
| <b>Total LCC</b>                              | 1 164 997  | 1 226 312   | 1 287 628  |
| <b>Tot LCC rounded up to closest thousand</b> | 1 165 000  | 1 227 000   | 1 288 000  |

As the vessel requires a complete docking system to operate, a LCC for the total system was calculated. In addition to the LCC for the vessel itself, the investment costs, operation costs and maintenance costs for the dock were calculated. This includes costs of the dock, gangway and elevator, and registration system, as well as electricity use and maintenance of the systems. The resulting total LCC can be seen in table 23.

Table 23: The LCC for the total system consisting of the dock and autonomous ferry

| <b>Cost</b>                                     | <b>Min</b> | <b>Mean</b> | <b>Max</b> |
|---|------------|-------------|------------|
| Investment cost vessel                          | 969 929    | 1 020 978   | 1 072 027  |
| Investment cost dock                            | 805 410    | 847 800     | 890 190    |
| Present value operation cost vessel             | 237 834    | 250 351     | 262 869    |
| Present value operation cost dock               | 296 799    | 312 420     | 328 041    |
| Present value maintenance cost vessel           | 330476     | 347 869     | 365 263    |
| Present value maintenance cost dock             | 84 859     | 89 325      | 93 792     |
| Present value of sales value                    | 373 242    | 392 886     | 412 531    |
| <b>Total LCC</b>                                | 2 221 911  | 2 338 854   | 2 455 797  |
| <b>Total LCC rounded up to closest thousand</b> | 2 222 000  | 2 339 000   | 2 456 000  |

The resulting LCCs that are found here only gives a rough estimate of the costs associated with the vessel. There might be costs that are considered too high or too low. Certain costs have not been considered. Not all systems and components for the vessel are set, and are therefore missing from the LCC. Classification costs and investment costs are also not considered here, but will represent a cost for the project.

The alternative to the vessel is building a bridge over the channel. Plans were made for such a bridge, and the estimated price was NOK 42 million according to the local newspaper in Trondheim(Svaan, 2012). If the plans were to move forward, new cost estimates for the bridge would be necessary. It is likely that the cost would be higher (Devik, 2016). Compared to the bridge, the ferry is economically beneficial with a total LCC of NOK 2.46 million, if the upper estimate is considered.



## 9 Results

The final results of the design study are formed by results from the evaluations and calculations performed throughout the process. Therefore, the sub-results are presented together with the final result. Parts of these results are repetition of results presented in the thesis. They are presented here again to give the reader an overview.

The resulting design is an autonomous ferry with electrical power supply and a ramp used for mooring and entrance. The building material is set to be aluminium. The ferry superstructure is semi - open with two broad pillars supporting the roof. The resulting ferry is presented in figure 61. Specifications for the resulting design is presented in table 24 below. The technical drawings of the vessel design are found in appendix F.

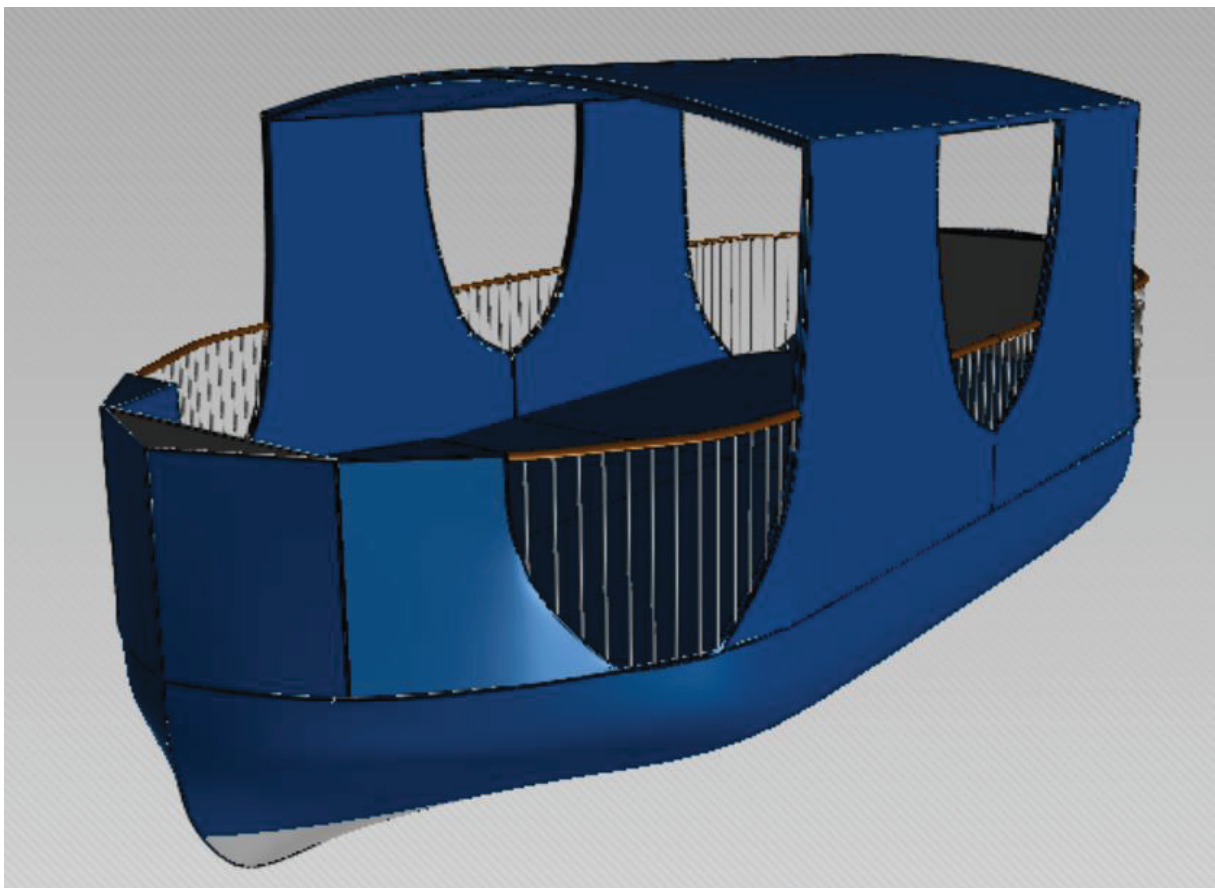

Figure 61: The Resulting Ferry Design

Table 24: Vessel specification table

| <b>SPECIFICATIONS - Ellen AuTomine</b>                     |   |
|--|---|
| <b>GENERAL</b>   |   |
| Vessel type  | Autonomous passenger vessel             |
| Area of operation  | Trondheim                               |
| Flag   | Norwegian                               |
| Max number of passengers                                   | 12                                      |
| <b>PRINCIPAL DIMENSIONS</b>                                |   |
| Length overall   | 9 m                                     |
| Beam   | 4 m                                     |
| Design draught   | 0.515 m                                 |
| Lightweight draught  | 0.446 m                                 |
| Lightweight  | 5.150 t                                 |
| Displacement   | 7.610 t                                 |
| Freeboard at designload                                    | 0.685 m                                 |
| <b>MACHINERY &amp; PROPULSION</b>                          |   |
| Main propulsion number                                     | 2                                       |
| Main propulsion  | Azimuth pods                            |
| Total propulsive power                                     | 20 kW                                   |
| Main propulsion power source                               | 2x PBES 400v, 26kWh battery modules     |
| <b>PERFORMANCE</b>   |   |
| Electricity consumption at max speed                       | Approx. 0.34 kWh per crossing @ 5 knots |
| Electricity consumption at operation speed                 | Approx. 0.14 kWh per crossing @ 4 knots |
| <b>PASSENGER AREA</b>                                      |   |
| Number of seats  | 12                                      |
| Number of bicycle racks                                    | 12                                      |
| Number of wheelchair spaces                                | 3                                       |
| <b>SAFETY EQUIPMENT</b>                                    |   |
| Life jackets adult   | x18                                     |
| Life jackets child   | x11                                     |
| Life jacket baby   | x 1                                     |
| Life buoy  | x 2                                     |
| Rescue ladder  | x 2                                     |
| <b>FIRE SYSTEM</b>   |   |
| Fire extinguishers on deck                                 | 2x powder extinguisher                  |
| Fire system battery room                                   | 2x 10 kg NOVEC 1230                     |
| Fire system thruster room                                  | 2x 12 kg NOVEC 1230                     |
| <b>COMMUNICATION EQUIPMENT</b>                             |   |
| Communication between passengers and central on land       |   |
| Communication between systems on board and central on land |   |
| Communication between ferry and other vessels              |   |

The ferry will dock at its own separate docks, not used by any other vessels. One dock is located at Ravnkloa and the other at Fosenkaia. The docks are surrounded by a fence to secure people from falling in the water. An information poster is located at each dock to inform passengers about relevant safety issues. They need to confirm that they have read this information when passing through the registration gate, in order to enter the ferry. The registration gates separates the ferry docking area from the people on the dock. When the ferry is securely docked, the gates can be opened by the passengers wishing to board the ferry. a call button is located in the registration gate. This may be used by passengers to call for the ferry if not at the dock. Benches are placed on the dock to make the passenger's waiting time more pleasant. The dock is designed with a pier supporting the ferry at one side. It supports the ferry against the currents in the channel, reducing the force acting on the ramp mooring. Entry to the dock is done using a gangway. For wheelchair users, an elevator is installed on the gangway.

The results from the stability calculations show that the vessel satisfies all IMO stability requirements for passenger vessels in 10 out of 14 loading conditions. The conditions not satisfied were the cases where all passengers were located at starboard side, 10 cm snow on the roof, 50 cm snow on the roof and three wheelchairs on starboard side. The requirement not approved is the dynamic stability requirements (AreaA/AreaB). To avoid snow on the roof, heating cables were included in the main deck and the roof. Wheelchair users are recommended to stand in the centre aisle of the vessel. This information is given on the information poster at the docks. The stability was also investigated for the wind strengths assumed to occur in the area. Here, the vessel satisfies all requirements in all loading conditions except 50 cm snow on the roof. The strength calculations concluded that the strength of the structure is sufficient according to DNV GL standards. Results from the resistance calculations revealed that the resistance of the vessel is estimated at 2000 N at forward speed 5 kn. This implies a power demand of 10 200 W. The battery modules included are satisfactory. The complete life cycle cost of the ferry is NOK 2.4 million. This equals NOK 39.6 million less than the estimated price for the bridge in the area.





## 10 Discussion

In this section, various aspects of the report will be discussed. First, an evaluation of the design approach is presented, followed by an assessment of how the final design performs with regards to the pre-defined functional requirements. Further, the passengers and limitations relevant for different passenger groups will be discussed. The emergency plans and solutions related to this will also be considered together with the iterative nature of the design process and how it affects the design.

### 10.1 Evaluation of the Result

The alternative to the ferry is to build a bridge over the channel. The ferry therefore had to be a good alternative. It was therefore designed for all passenger groups, and the possibility to operate continuously over longer periods of time. Using the ferry might result in some waiting time, if the passengers arrive while it is docked at the opposite side of the channel. This would not be a problem with a bridge. The bridge is planned to be a bascule bridge, meaning that it can open to provide clearance for boat traffic. If the bridge is open, there would be waiting time for the pedestrians. It would likely be longer than waiting for the ferry. The bridge would be more intruding in the surroundings than the ferry. The addition of two floating docks would require less space than the bridge, and be less of an obstacle for passing boat traffic in the area. The ferry also helps preserve the tradition of the "Fløttmann" who rows people across the channel. The call button for the ferry is similar to the bell signal traditionally used to call the "Fløttmann". Finally, the ferry has a much lower cost than the bridge. The LCC analysis shows that the investment cost for the ferry is NOK 1.2 million, and the total LCC over 15 years (including dock system) is NOK 2.4 million. This is significantly lower than the estimated price tag for the bridge, which is set to NOK 42 mill (Svaan, 2012). Based on this, the ferry is a good alternative to the bridge. The functional requirement to replace a bridge in the area to a reasonable degree, is thus fulfilled. The next section will further discuss the remaining functional requirements.

## 10.2 Performance with Regards to Functional Requirements

The functional requirements set for the ferry should be fulfilled in the final design. The main function in this study is to be able to transport people across the channel between Ravnkloa and Fosenkaia in Trondheim without the need for personnel. The vessel designed can fulfill this function, as well as dock autonomously without personnel present. However, the autonomous system to operate the vessel is not yet finished. The task of designing this system was given to two students at the Department of Engineering Cybernetics, and is still under development. The integration of the vessel system and the autonomous system has therefore not yet been tested. Ideally, the autonomous system should have been designed first or at the same pace as the vessel, so that all interactions and functional requirements related to it could be tested. The resulting design in this thesis is designed so it has all the functionality necessary to operate as an autonomous vessel. The utility remains to be tested when the autonomous system is completely developed.

Another important functional requirement of this vessel is to be able to transport 12 passengers with their bicycles. To make sure the vessel has sufficient space the team has performed several tests of the required area on the main deck. The final design allows for 12 people and 12 bikes to use the ferry at the same time. The design has bicycle racks so that the bicycles can be placed orderly. There is also enough area on the deck for all the passengers to stand holding their bikes. The functional requirement is thus fulfilled.

As the vessel is to operate autonomously, the safety on board the vessel is of high priority. To make sure the safety related functions were met, a risk assessment was performed. The risk assessment resulted in a number of risk control measures. Some of the measures implemented in the design include; a collision bulkhead at both sides of the vessel to make it less likely for it to sink in case of a front collision and emergency related buttons for the passengers to be able to contact help or stop the ferry. Extra firefighting equipment, extra life jackets and anchors that can drop if navigational equipment fails. All safety related functional requirements resulting from the risk assessment are fulfilled in the final design. They will also to a varying degree contribute in fulfilling the safety related functions. However, the freeboard of the ferry is precisely high enough, and it should be considered to add some extra bulwark where there is railings in the design. This would lift the freeboard, and make the safety level of the vessel somewhat higher. Further, the design

as it is now does not have any emergency batteries. If the two battery modules run out of electricity or stop functioning, there is no way of manoeuvring the vessel or to communicate with land. An emergency battery that only power the necessary equipment in an emergency situation should be considered added to the vessel. Whether this design is sufficiently safe has to be verified by the Norwegian Maritime authority.

The vessels ability to float stable is an important functional requirement. To make sure the vessel has sufficient stability, a strict stability criteria was used for the stability analysis. The stability criteria ensures that the vessel is stable under all conditions in the channel. In addition, the vessel was tested for different loading conditions. These represent cases involving crowding of passengers and heavy snow loads on the vessel. As extra precautions a max weight limit has been set, and heat cables has been added to the ferries roof and floor. A weather restriction was also imposed on the ferry, stopping operation in harsh weather conditions. Results from this analysis, together with the extra precautions, verify that the stability requirement is fulfilled.

The strength of the vessel was also verified. A drawing of the midship cross section was made, and the section modulus for this was calculated. The bending moments and shear forces for different loading conditions were also investigated, and found to be within the requirements from DNV GL and NBS. This contributes to fulfilling the requirement for the structure to withstand all foreseeable loads during its lifetime.

As the vessel is a passenger ferry, the comfort of the passengers is of key importance for the design. The requirement of a high level of passenger comfort was ensured by different measures. The ferry has seats for the maximum allowed passengers so that everyone can sit during the crossing. It also has a roof over the seats, that somewhat shields the passengers from the weather. There is plenty of space for the passengers, so that they don't feel crowded like on a full bus. The space also makes it easy for a wheelchair user to navigate and move around. The ferry has been left open so that the passengers can see the surroundings during the crossing. For passengers who bring their bicycle there are racks where they can place them. Embarking and disembarking from the ferry has been made simple with a dock layout that focus on passenger flow. The ferry was given its

own dock, to avoid traffic from other vessels. The dock and vessel have no casings, making it easy for wheelchairs to use the ferry. The dock also has a wheelchair elevator for easy access.

To ensure that the ferry satisfied the requirement to operate the required number of hours, the batteries chosen had to provide sufficient energy. This was verified through the resistance calculations. The operational profile show that there is enough capacity using the two battery modules to last through the most busy periods for the ferry. It has not been verified how the batteries will perform for lower temperatures. The temperatures in the operational area will vary, and the lithium batteries lose effect in lower temperatures. This implies that on colder days, the battery life would be shorter. To assure that the vessel always has enough battery, a heater could be added to the battery room to keep the temperature sufficiently high on colder days.

To make the vessel able to navigate as correctly as possible, a hull with good directional stability was chosen. When choosing the hull shape, different factors were considered, and the team eventually chose on the monohull. Still, the catamaran hull could have been an equally good solution. Further investigations could have been made, by for example performing model tests, and a more accurate conclusion could have been made. Based on the preceding discussion, all functional requirements set to the design is considered fulfilled to a reasonable degree.

### **10.3 Restriction of Passenger Groups**

The ferry was designed for use by all passenger groups, but it is reasonable to discuss who can use the ferry alone. The layout of the ferry should allow both kids and handicapped passengers access to emergency equipment. However, a person who is handicapped or a child might not be able to help themselves in case of an emergency. An age restriction for kids travelling alone might therefore be necessary. It might also be a requirement for a passenger who can not help themselves to travel with a companion. It is difficult to chose an age restriction. The ferry is designed to be user friendly, and it should be possible for young children to use the ferry without difficulty. The challenge is in the understanding of what happens in an emergency situation. Information about this will be available on the dock and on board the vessel. If this info does not come across to the child, they

might be at a higher risk in an emergency situation. One possible restriction age is 12 years old. At this age, they can most likely read and will be able to understand what to do if an emergency should occur. Another possibility is setting the restriction to 16 years old. 16 is the age at which you can get your certificate of boatmanship, and pilot boats larger than 8 m. An age limit higher than this is unreasonable. The access restriction needs to be determined in cooperation with the Norwegian Maritime Authority, to ensure compliance with future regulations on autonomous vessels. Continuous contact with the Norwegian Maritime Authority during the thesis work, did unfortunately not result in any clear conclusions.

#### **10.4 Emergency Plan and Information**

The ferry has two buttons that allows the passengers to stop the vessel and to contact help on land. Having a stop button on the ferry induce the risk of passengers pushing it simply to test it. This is not commendable as the button stops the ferry transit. It then has to be checked by the supervisor before operation may continue. It would also be uncomfortable for other passengers on board if the ferry stops half way over the channel. A possibility is to fine passengers who push the button when it is not necessary. The surveillance cameras on board can identify the person who pushed the button.

The ferry has fire detectors below deck and up under the roof. It also has fire extinguishers on deck so that the passengers can put out fires if necessary. If a fire should break out on deck, the passengers can call for help with the call button. It could however be necessary with a separate fire alarm button that allows the passengers to directly alert the fire department. Such a button has not been implemented in the design, but could be added at a later stage if found to be necessary. By having a separate button for fire alert, passengers pushing the emergency stop button in panic during a fire can be avoided. Pushing the emergency stop button would alert that something is wrong on the ferry, but would also stop the ferry from moving towards land where it is safe.

## 10.5 Evaluation of the Design Approach

The design approach chosen for this study was a combination of the marine design method, SBSD, and the risk based design approach RBSD. The combination was deemed necessary, as the autonomous aspect of the vessel sets new requirements to the level of safety. By including the RBSD method, safety related decision parameters were used throughout the design process. There are however weaknesses in using the RBSD approach for this case. One is that the approach use similar existing designs as a comparative basis in the analysis. As no autonomous vessels are available on the market, no such comparative basis exist. When evaluating the risk of the vessel in this study, a preliminary concept was assumed so that the FSA could be performed. The FSA performed in this study was based on the intuition of the team members. A more in depth analysis would have used statistical information to set the probabilities and frequencies for all hazards investigated, giving a more dependable result. Further, the autonomous system could be investigated in detail if all components where known. In this study, it is considered a source of error as no details of the system was available. More in depth methods could be used to reveal hazards at the component level. This study only considered the entirety of the vessel system. Had the risk assessment been taken further, the components linked to the critical hazards could have been assessed in detail. This may have resulted in more focused risk reducing measures. Thus, there is room for improvement.

Another weakness in the RBSD approach is that it requires that acceptance criteria are defined. The criteria can be based on regulations, or be set by comparison to a baseline vessel. No regulatory framework exist that can set the necessary criteria. In this study, the ALARP risk criteria was used. This is usually a reasonable requirement, but since no confirmation of the criteria have been given by the Norwegian Maritime Authority, it is considered a significant uncertainty in the results. Criteria could be set directly by the Norwegian Maritime Authority. These would have to be fulfilled for the design to be sufficiently safe. Despite the uncertainties, the study has resulted in a good basis for further communication and discussions with the Norwegian Maritime Authority. Another uncertainty in the risk assessment is that the result of the risk reduction was not verified in detail. The updated probabilities and consequences were not evaluated according to the RPN scale. It was thus not concluded whether or not the risk had been reduced

to the ALARP level or lower. The only conclusion made was that the probability and consequence was somewhat reduced. The ideal solution would be to use an acceptance criteria, set by the Norwegian Maritime Authority as they will be approving the design. This would work similar to the theory used to evaluate damage stability, where  $R_{Design}$  has to be lower than  $R_{Accept}$ .

The SBSB approach is good when designing something new. It is not based on existing vessels and allows for innovation in the design. Several alternative solutions are considered to find the best solution. However, when an initial solution is set, the volume and area requirements, as well as required power for the vessel are normally set based on comparison to other vessels in the same design category. In this study, the SBSB for passenger ferries was used (Levander, 2012). The passenger ferries used for the statistical information in this SBSB are much larger than the vessel in this study. These statistics were therefore not applicable. Using statistics from fishing vessels might have given an acceptable estimate, but their operation is different than for a passenger vessel. Due to this, the approach was slightly altered for this study, setting the required space and power based on existing equipment considered installed on the vessel.

As the space on board is based on the systems to be installed, all details on the systems needed has to be known. The autonomous system for the vessel in the study is not designed in detail. If it at a later stage is revealed that this system contains volume critical components, the volume appointed for the system might be too small. It might also require a change in the arrangement on board. The autonomous system should therefore be considered a weakness in the resulting design. More detailed information on the system layout should be obtained as soon as possible in the further work.

The SBSB approach in this study is based on functional requirements. These functional requirements might not cover all necessities of the ferry system. For example, the functional requirements define that it is required for the vessel to be able to moor autonomously. Mooring using ropes was early in the process discarded as a possible solution as there is no crew on board the ferry. The mooring function is fulfilled by use of a ramp. However, the ferry should still have the opportunity to moor by ropes if it needs to be moored to a different dock than the ones in the operational area, specifically fitted to the ramp mooring. To do this, bollards and rope has to be available on the ferry. This

necessity could easily be overlooked as the functional requirements only looks at the ferry mooring at its own docks, due to the operational area limitation. Rules and regulations help cover some of the requirements that are missed in the functional analysis. An example is the requirement for the vessel to have bollards in case it needs to be towed. This is not covered by the functional requirements set for the ferry, but is required from regulations. Functionality that is missed in the functional analysis and by regulations, might therefore not be present on the ferry in the final design. This is considered a flaw in the functional analysis.

## **10.6 The Iterative Nature of the Design Process**

The iterative nature of the design process indicate that multiple small changes appear towards the end of each iteration. Small flaws arise as the design progresses, necessitating improvements of the design. The further the design progresses, the more information is available. This information enables the designer to improve the design further.

In this study two iterations were made, and possible improvements of the design has surfaced throughout the process. Further iterations of the design could improve it further. Final design of the autonomous system is one of the details in this study that could result in substantial changes in the design. New volume critical components would change the volume requirement of the vessel. A more detailed risk analysis could also reveal safety measures that are necessary to secure sufficient safety levels. These measures could lead to changes in the size, design or weight of the vessel, as well as increase the costs of the vessel. It is apparent from this discussion, that the iterative nature of the design process naturally suggests several tasks for the further project work.



## 11 Further Work

NTNU, with Egil Eide has stated that the autonomous ferry project will continue after this thesis. The plan is that other students will continue the work from this thesis and improve the design further. This chapter will discuss what is considered the most relevant further work for this study, presented in two separate sections to give a better overview. Section 11.1 presents the work that should be re-evaluated and unfinished parts of the study that need further attention. Section 11.2 will discuss aspects not covered in this study that is considered relevant for the continuation of the ferry project.

### 11.1 Improve the Current Design

The formal safety assessment in this study is based on the design teams intuition and assumptions. The results are considered qualitative as the probabilities are set by use of a qualitative scale and comparison of the risks, and not according to statistics. The results from the assessment could therefore be more accurate and verified. It is suggested that the probabilities used in the risk assessment are reconsidered in the further work to get a more quantitative result. It would also be beneficial to continue the assessment and examine the most critical events in further details. This would provide a better basis for determination of the safety related functional requirements. Some of the requirements set in this study may prove to be irrelevant, while new ones may also appear. As these set the basis for determining the ferry design, it is an important part of the further design work.

Before continuing the autonomous ferry project, the entire resulting design should be reconsidered. The time limitation for the thesis may affect the resulting design. The possibility of lowering the roof of the superstructure could be examined, as lowering the centre of gravity would improve the vessels stability further. As discussed earlier, the main deck needs to be raised to make room for the battery modules below deck. An alternative is to place the batteries lying down so that the battery panels are opened vertically instead of horizontally. A request was sent to PBES to verify this alternative. No confirmation was obtained in this thesis, and thus the alternative may not be applicable. Further, it would be beneficial to evaluate the hull shape using a model test in a towing tank. This

way, the resistance could be estimated more exact than in the ShipX software. It would also be possible to test the hull with different draughts to map how it should be formed to move optimally in the water. If model tests were possible, it would be beneficial to test a catamaran hull as well. This way, the designer would be able to choose the best hull that performs best for this specific case.

Verification and possible redesign is also relevant regarding the arrangement of the outfitting and passengers on board. In particular, the arrangement of bicycles on board should have detailed plans. The bicycle rack design should be set in more detail to ensure that they function as good as possible with the rest of the vessels outfitting and passenger groups. The current arrangement of ship outfitting and equipment could also be evaluated using a room-lab. Alternative arrangements could also be tested. If the hull and/or arrangement is changed, new verification of the design would be necessary. This includes the strength- and stability calculations as well as determining the life cycle costs. The ballast could be considered removed if no longer necessary. The new test should be performed using a new 3D model where the rooms and weights are set according to the arrangement. This was not accomplished in this study as the arrangement was changed after the 3D model was completed.

As there were no regulations available for autonomous vessels when this thesis was produced, the design in this study was set according to the Nordic Boat Standard. The strength criteria used were taken from DNV GL's standard for vessels less than 100 metres, and the stability criteria used was the IMO standard for passenger vessels. This was done because the future regulations for autonomous vessels is likely to be stricter than the NBS requirements. As the IMO- and DNV GL standards set significantly stricter requirements, it is likely to fit the future regulations better. These regulations will be set by the Norwegian Maritime Authority. If new calculations were to be performed, dialog with the Norwegian Maritime Authority will therefore be important.

## 11.2 New Aspects for Consideration

As time was limited for this study, several aspects of the complete system design was not considered in detail. It is possible that these systems will set limitations or requirements to the ferry design that were not discovered in this study. The relevant systems include

the floating dock and its surrounding elements, hatches in the main deck, the autonomous system on board the ferry and on land, the mooring ramp, heat cables in the dock, , ferry deck and -roof. Regulations were also a significant part of the research work. A complete master's thesis could be written on this subject alone. This will be an important part of the further work. Relevant problems to investigate are the access restrictions on the ferry, required safety level, the disclaimer of liability and technical requirements for autonomous vessels. All problems need to be addressed in cooperation with the Norwegian Maritime Authority, to ensure compliance with future regulations on autonomous vessels.

Design of the autonomous system requires excellent cybernetic skills and a large amount of resources. As non of the team members have this knowledge, the software part of the autonomous system was not considered in this study. The ferry design was made to fit the physical parts of the system in the best possible way. For instance by enabling correct placement of sensors and the automatic mooring. The software should be designed in coordination with the team proceeding with the ferry design, to obtain the best possible integration of the two. It may be possible to make the design of this system part of a master thesis similar to this design study. It would be suitable for cybernetics students. The most important functions of the autonomous system would be to control the ferry's navigation and secure that its passage over the channel is safe. It would also need to control the docking of the ferry, as well as communicate with the dock systems for the passenger registration and boarding. Further, the system should monitor all equipment on board and take appropriate precautions to maintain the passengers safety and comfort while on board. If the weather is to rough, the system needs to register this and keep the ferry at the dock. The same applies to the case where the battery capacity is below a preset limit. The ferry would need to stop operation and charge the batteries to a sufficient level.

The land based system will need to be designed in more detail. The design was limited to the concept stage, as the ferry is the main focus. Therefore, the gangway with the elevator, the dock layout and the passenger registration system needs further detailing. These individual systems should be developed considering the entirety of the land based system, to secure the best possible functionality and efficiency. The sketches and discussions made in the thesis may provide useful input for the initial design. The heating cables that were to be mounted in the floating dock should be considered. The mooring ramp should

also be included as it will affect what is the best floating dock design. The ramp design should be tested in practice to ensure that its functionality will be as intended. As there are no similar systems available, the team can not say with certainty that it will be the best possible solution for the mooring. Other solutions may therefore also be relevant for consideration.

Several systems on board the vessel will be relevant for the further work. Heating cables were to be mounted in the ferry roof and main deck. The requirements to this system was not investigated in this study and should therefore be considered. It is possible that heating cables will set new requirements to the hull design or plate thicknesses. This is also something that should be evaluated in the further design work. The plate thickness was in this study set to be five millimetres for most of the plates. This may not be the best alternative when the welding and construction of the vessel is considered. It is therefore considered to be an important part of the further work to investigate necessary changes to the ferry structure. The appropriate aluminium alloy must also be determined. As previously discussed, large parts of the hull is made up of double curvature. In order to make the hull construction easier, less time consuming and cheaper, the hull should be remodelled to using chines instead. The bicycle racks were another system part not considered in detail. As seen in the general arrangement drawings, two racks are mounted under each seat. The bicycle racks are currently mounted rigid onto the main deck. Another possibility could be to use racks that are foldable. This way, they could be folded towards the wall and thus take up less space in the room when not in use. The detail design of the bicycle rack may be considered as a separate design project or included in the further work on the ferry design. Either way, both the ferry design and bicycle rack design needs to be considered as a whole to ensure the best possible functionality.

Further, the battery system needs to be designed for the ferry operation to run as smoothly as possible. This thesis investigated the necessary capacity of the batteries and looked at what would be the best placement on board the vessel. The operational plan of the batteries was not considered, yet it will be an important factor in the operational success of the ferry. The best way of using the batteries is therefore an important part of the further work. One alternative will be to use power from one of the modules until it is empty and then start using the other. Another possibility would be to use power from

one module from Ravnkloa to Fosenkaia and the other one on the way back. Several other alternatives will also be relevant and detailed analysis will be necessary to determine the best logistic.

The damage stability of the vessel should be assessed. This was excluded from this master thesis due to time limitations. It will be relevant to test the vessels damage stability to determine maximum evacuation time if the vessel should start to take in water. This information will be important when in dialog with the Norwegian Maritime Authority on whether or not they will approve the vessel design. Finally, the ferry needs a complete emergency- and evacuation plan. This has to be made according to regulations. These plans have not been formed in this study. It is important that these plans are concrete and descriptive so that the passengers are aware of what to do in an emergency situation, as there are no crew there to guide them. The plans have to be displayed on the ferry and at the dock. They should include all capacity restrictions, information about safety equipment with their placement and the evacuation routes on the vessel.



## 12 Conclusion

The main objective of this study was to determine the best possible design of an autonomous ferry to transport people between Ravnkloa and Fosenkaia in Trondheim. It was also considered whether or not it will be a better solution than a bridge.

The result of this study is the design of an autonomous ferry with electrical power supply and a ramp used for mooring and entrance. The ferry is 9 m long with a beam of 4 m. The design draught of the vessel is 0.515 m. The ferry can transport up to 12 passengers, including three wheelchairs, and 30 kg luggage per person. There is also room for twelve bicycles on board. The building material is aluminium. The ferry superstructure is semi-open with two broad pillars supporting the roof. The ferry will dock at piers separated from other docks in the area. An information poster is located at the dock to inform passengers on relevant safety issues. The registration gates lock of the docking area to the people on the dock. Entry to the dock is done using a gangway. The design ensures that the passenger comfort is sufficiently good.

The ferry is able to transport all types of pedestrians, and is thus able to substitute a bridge. The weakness of the ferry option is that passengers may need to wait a few minutes to use ferry. The ferry's life cycle costs were estimated at approximately NOK 2.4 million over 15 years. This is significantly lower than the price tag for the bridge, and the ferry is thus considered a good alternative.

All functional requirements set to the design are considered fulfilled to a reasonable degree. Having a stop button on the ferry induce the risk of passengers pushing it simply to test it. A possibility is to fine passengers who push the button when it is not necessary. If a fire should break out on deck, the passengers can call for help with the call button. It could be necessary with a separate fire alarm button that allows the passengers to directly alert the fire department. Such a button has not been implemented in the design, but could be added at a later stage if found to be necessary.

A flaw in the RBSD method is that the FSA performed in this study was based on the intuition of the team members. A more in depth analysis would have used statistical information to set the probabilities and frequencies for all hazards investigated. This is considered a source of error in the results. Thus, there is room for improvement. Another

weakness in the RBSD approach is that it requires that acceptance criteria are defined. No regulatory framework exist that can set the necessary criteria. The ALARP risk criteria was used, but no confirmation of the criteria have been given by the Norwegian Maritime Authority. It is considered a significant uncertainty in the results. Despite the uncertainties, the study has resulted in a good basis for further communication and discussions with the Norwegian Maritime Authority. Finally, an uncertainty in the risk assessment is that the result of the risk reduction was not verified in detail. The only conclusion made was that the probability and consequence was somewhat reduced. The ideal solution would be to use an acceptance criteria, set by the Norwegian Maritime Authority.

The SBSB approach is good when designing something new. It is not based on existing vessels and allows for innovation in the design. The passenger ferries used for the statistical information in this SBSB are much larger than the vessel in this study, and the statistics were therefore not applicable. The autonomous system is not designed in detail. If it at a later stage is revealed that this system contains volume critical components, the volume appointed for the system might be too small. The autonomous system should therefore be considered a weakness in the resulting design. More detailed information on the system layout should be obtained as soon as possible in the further work. The SBSB approach was based on functional requirements. These functional requirements might not cover all necessities of the ferry system. Rules and regulations help cover some of the requirements that are missed in the functional analysis. Functionality that is missed will not be present on the ferry in the final design. This is considered a flaw in the functional analysis.

The iterative nature of the design process indicate that multiple small changes appear towards the end of each iteration. It therefore naturally suggests several tasks for the further project work. These include improvement of the risk assessment, model test of the hull and verification of arrangement. It will also be relevant to consider all aspects set by regulations. This includes strength requirements and stability requirements. New aspects for consideration include design of land based dock systems and determination of access restrictions, required safety level, disclaimer of liability and technical requirements for autonomous vessels. Design of the autonomous system will also be part of the further work. This task is suitable for cybernetics students. Several aspects on board the vessel are relevant for the further work. This includes heating cables in the ferry roof and main



deck, verification of plate thickness, hull adaptation for welding and design of bicycle racks. The operational plan for the battery systems should be determined for the ferry operation to run as smoothly as possible. Finally, the damage stability for the vessel should be verified.



## Bibliography

- 3M (2017). Noves 1230 - fire protection fluid. Personal Communication. Retrieved: 03.05.2017.
- Aanondsen, S. A. (2017). Generic design spiral. Personal Communication. 11.01.2017.
- Anderson, J. M., Nidhi, K., Stanley, K. D., Sorensen, P., Samaras, C., Oluwatola, O. A., Rand Transportation, S., (Program), T., and Corporation, R. (2014). *Autonomous Vehicle Technology : A Guide for Policymakers*. RAND Corporation, Santa Monica.
- Aquamot (2017). Steerable pod motors. <http://www.aquamot.at/en/marine/products/professional-line/steerable-pod-motors.html>. Retrieved: 11.05.2017.
- Asbjørnslett, B. E. (2015). Cost benefit analysis in formal safety assessment. Lecture Notes. Retrieved: 21.04.2017.
- Carlton, J. (2011). *Marine propellers and propulsion*. Butterworth-Heinemann.
- Choma, E. F. and Ugaya, C. M. L. (2015). Environmental impact assessment of increasing electric vehicles in the brazilian fleet. *Journal of Cleaner Production*.
- Cross, N. (1989). *Engineering design methods*. Wiley, Chichester.
- Davis, J. R., Davis, J. R., et al. (1993). *Aluminum and aluminum alloys*. ASM international.
- Devik, I. A. (2016). Personal Communication. Date: 07.10.2016.
- DNV GL, . (2012). Hull structural design, ships with length less than 100 meters. <https://rules.dnvgl.com/docs/pdf/DNV/ruleship/2012-01/ts302.pdf>. Retrieved: 22.05.2017.
- DNV GL, . (2017). The revolt. <https://www.dnvgl.com/technology-innovation/revolt/>. Retrieved: 28.05.2017.
- Doctors, L. J. (2017). On the great trimaran-catamaran debate. <http://mararchief.tudelft.nl/file/37021/>. Retrieved: 23.05.2017.
- Eide, E. (2017). Personal Communication. Date: 15.03.2017.

- Endal, A., Fuglerud, G., et al. (2011). *Kompendium - TMR4105 Marin Teknikk 1*. NTNU.
- Engebakken, A., Ørjan Grefstand, et al. (2017). Ombordstigningssystem for den autonome fergen milliampère. NTNU. Retrieved: 03.05.2017.
- Engelø, M. (2017). Datasheet kidde cylinder. Personal Communication. Retrieved: 03.05.2017.
- Erichsen, S. (1999). *Elements and techniques of marine design*. MTS, Trondheim.
- Erikstad, S. O. and Levander, K. (2012). System based design of offshore support vessels. [https://www.researchgate.net/profile/Stein\\_Erikstad/publication/276958126\\_System\\_Based\\_Design\\_of\\_Offshore\\_Support\\_Vessels/links/555c946008ae8c0cab2a60b3.pdf](https://www.researchgate.net/profile/Stein_Erikstad/publication/276958126_System_Based_Design_of_Offshore_Support_Vessels/links/555c946008ae8c0cab2a60b3.pdf). Retrieved: 05.02.2017.
- Evans, J. H. (1959). Basic design concepts. *Journal of the American Society for Naval Engineers*, 71(4):671–678.
- Falvey, K. (2004). Catamaran versus v-hull: Which rides better? <http://www.boatingmag.com/boats/catamaran-versus-v-hull-which-rides-better>. Retrieved: 23.05.2017.
- Flaus, J. (2013). *Preliminary Hazard Analysis*. Hoboken, NJ USA: John Wiley & Sons, Inc., Hoboken, NJ USA.
- Gedde-Dahl, S. (2017). Personal communication. Telephone call.
- Gemini (2016). Åpner testområde for ubemannede fartøy. <http://gemini.no/2016/09/apner-testomrade-ubemannede-fartoy/>. Retrieved: 26.03.2017.
- Girardi, P., Gargiulo, A., Brambilla, P., and Girardi, P. (2015). A comparative lca of an electric vehicle and an internal combustion engine vehicle using the appropriate power mix: the italian case study. *International Journal of Life Cycle Assessment*, 20(8):1127–1142.
- Google Inc, . (2017). Google maps. <https://www.google.no/maps/place/Ravnkloa+fisk+%26+Skalldyr+AS/@63.4338226,10.3902684,17z/data=!3m1!4b1!4m5!3m4!1s0x466d319b572c79d7:0x4c95a71399a98278!8m2!3d63.4338202!4d10.3924571?hl=no>. Retrieved: 20.02.2017.

- Hagen, A. (2016). *KOMPENDIUM Skipsbygging*. NTNU.
- Havdal, G., Larssen, C., and Heggelund, C. (2016). Preliminary research for design of autonomous ferry.
- Hawkins, T. R., Singh, B., Majeau-Bettez, G., and Strømman, A. H. (2012). Comparative environmental life cycle assessment of conventional and electric vehicles. *Journal of Industrial Ecology*.
- Helms, H. e. a. (2010). Electric vehicle and plug-in hybrid energy efficiency and life cycle emissions.
- Hjerteplanen (2017). Bro ved ravnkloa. <http://hjerteplanen.no/prosjekter/hjertepromenaden/bro-ved-ravnkloa/>. Retrieved: 18.05.2017.
- IMO VEGA, . (2002). Guidelines for formal safety assessment (fsa) for use in the imo rule-making process. <http://vp.imo.org/Custom/Subscriptions/IMOVEGA/MemberPages/IMODocument.aspx?resultIndex=32&docId=MSCC1023ACI&docDate=2016-11-30>. Retrieved: 25.01.2017.
- Jakobsen, K. (1990). *Produktutvikling*.
- Jensen, R. C. (2007). Risk reducing strategies; past, present and future. [http://www.oshrisk.org/docs/Risk\\_Reduction\\_Strategies.pdf](http://www.oshrisk.org/docs/Risk_Reduction_Strategies.pdf). Retrieved: 20.04.2017.
- Kongsberg (2017). Autonomous shipping. <https://www.km.kongsberg.com/ks/web/nokbg0240.nsf/AllWeb/597733F8A1B8C640C12580AC0049C134?OpenDocument>. Retrieved: 18.05.2017.
- Kullmann, A. B., Asbjørnslett, B. E., and Aanondsen, S. A. (2016). A comparative life cycle assessment of conventional and all-electric car ferries.
- Levander, K. (1991). System based passenger ship design.
- Levander, K. (2012). *System Based Ship Design*. NTNU Marine Technology.
- Lloyd's Register, . (2016). Cyber-enable ship; shipright procedure - autonomous ships. <http://www.lr.org/en/services/safe-cyber-technology-for-marine.aspx>. Retrieved : 06.03.2017.
- Lovdata (2014). Forskrift om redningsredskaper på skip. <https://lovdata.no/>

- dokument/SF/forskrift/2014-07-01-1019/KAPITTEL\_1#KAPITTEL\_1. Retrieved: 02.05.2017.
- MAN Diesel & Turbo, . (2017). Basic principles of ship propulsion. <https://marine.man.eu/docs/librariesprovider6/propeller-aftship/basic-principles-of-propulsion.pdf?sfvrsn=0>. Retrieved: 02.05.2017.
- Maritime Robotics, . (2017). A long duration creation. [http://maritimerobotics.com/wave\\_glider/](http://maritimerobotics.com/wave_glider/). Retrieved: 28.05.2017.
- Medhaug, S. D., Spångberg, J. K., and Vaagen, E. (2017). Personal Communication. Retrieved: 19.05.2017.
- Met office, . (2016). Beaufort wind force scale. <http://www.metoffice.gov.uk/guide/weather/marine/beaufort-scale>. Retrieved: 18.05.2017.
- MUNIN (2017). Research in maritime autonomous systems project results and technology potentials. <http://www.unmanned-ship.org/munin/wp-content/uploads/2016/02/MUNIN-final-brochure.pdf>. Retrieved: 18.05.2017.
- NFAS (2016). Norsk forum for autonome skip. <http://nfas.autonomous-ship.org/>. Obtained: 18.05.2017.
- Nicolay, S. (2000). A simplified lca for automotive sector - comparison of ice (diesel and petrol), electric and hybrid vehicles.
- Nicolaysen, S. O. M. (2017). Personal communication.
- Norges Standardiseringsforbund, . (1993). *Teknisk Tegning*.
- Norgeskart (2016). Map of the area between ravnkloa and fosenkaia. [http://www.norgeskart.no/?\\_ga=1.64497321.782029773.1474570461#16/270257/7042287](http://www.norgeskart.no/?_ga=1.64497321.782029773.1474570461#16/270257/7042287). Retrieved: 13.09.2016.
- Norsk Geotekniske Institutt, . (2014). Renere havn. <https://www.trondheim.kommune.no/renerhavn/>. Retrieved: 07.04.2017.
- Nortronik (2016). Prosjekt: 5096-2-bygg283.batteri rom. Personal communication. Retrieved: 03.05.2017.

- Oxford Living Dictionaries, . (2017). Autonomy. <https://en.oxforddictionaries.com/definition/autonomy>. Retrieved : 06.03.2017.
- Papanikolaou, A. (2009). *Risk-based ship design : methods, tools and applications*. Springer, Berlin.
- Parkinson, A. (2015). Sailboat debate: Monohull vs. catamaran. <http://www.yachtsinternational.com/technology/sail-debate-monohull-vs-catamaran>. Retrieved: 23.05.2017.
- Partnoy, F. (2012). The cost of a human life, statistically speaking. <https://www.theglobalist.com/the-cost-of-a-human-life-statistically-speaking/>. Retrieved: 21.04.2017.
- Pedro Marques, R. G. and Freire, F. (2013). Life cycle assessment of electric and conventional cars in portugal.
- Pettersen, B. M. (2017). 27 ft recreational vessel. Personal Communication. Date: 31.03.2017.
- Plan B Energy Storage, . (2017). Meeting 24.04.2017. Personal communication. Retrieved: 24.04.2017.
- Rausand, M. (2013). *Risk Assessment : Theory, Methods, and Applications*. Statistics in Practice. Wiley, Hoboken.
- Rødseth, Ø. J., Kvamstad, B., Porathe, T., and Burmeister, H.-C. (2013). Communication architecture for an unmanned merchant ship. In *OCEANS-Bergen, 2013 MTS/IEEE*, pages 1–9. IEEE.
- Rolls Royce, . (2017). Rolls-royce announces investment in research & development for ship intelligence. <https://www.rolls-royce.com/media/press-releases/yr-2017/08-03-2017-rr-announces-investment-in-research.aspx>. Retrieved: 18.05.2017.
- Rudow, L. (2013). Power cat versus monohull: Which is the better fishing boat? <http://www.boats.com/boat-buyers-guide/power-cat-versus-monohull-which-is-the-better-fishing-boat/#.WSPzq2jyg2y>. Retrieved: 23.05.2017.

- Ruegg, R. T. and Marshall, H. E. (1990). *Building Economics: Theory and Practice*. Springer US : Imprint: Springer.
- Sintef Byggeforsk, . (2005). 320.100 menneskers rekkevidde og plassbehov. <https://bks.byggeforsk.no/DocumentView.aspx?sectionId=2&docNumber=320100>. Retrieved: 20.02.2017.
- Sintef Byggeforsk, . (2006). 220.335 dimensjonering for rullestol. [https://www.byggeforsk.no/dokument/3024/dimensjonering\\_for\\_rullestol](https://www.byggeforsk.no/dokument/3024/dimensjonering_for_rullestol). Retrieved: 17.02.2017.
- Sintef Byggeforsk, . (2015). 312.130 parkeringsplasser og garasjeanlegg. <http://bks.byggeforsk.no/DocumentView.aspx?sectionId=2&documentId=61#i6>. Retrieved: 20.02.2017.
- Standard Norge, . (2010). Iso 12100: Safety of machinery - general principles for design - risk assessment and risk reduction. <http://www.standard.no/en/PDF/FileDownload/?redir=true&filetype=Pdf&preview=true&item=594401&category=5>. Used: 14.03.2017, Not Available for Download.
- Statheros, T., Howells, G., and Maier, K. M. (2008). Autonomous ship collision avoidance navigation concepts, technologies and techniques. *Journal of Navigation*, 61(1):129–142.
- Statistics Norway, . (2016). Population and population changes, 2016, estimated figures. <https://ssb.no/befolkning/statistikker/folkemengde>. Retrieved: 19.02.2017.
- Steen, D. F. . S. (2000). Shipx wave resistance plug-in (waveres) 3.0- user's manual. Retrieved: 30.04.2017.
- Steen, S. (2017). Personal communication. Date: 15.02.2017.
- Svaan, T. (2012). Ravnkloa kan få gangbru. <http://www.adressa.no/nyheter/trondheim/article6640757.ece>. Retrieved: 23.05.2017.
- Teknisk Ukeblad, . (2015). Snart kan du lese avisen mens du kjører til jobb. <https://www.tu.no/artikler/snart-kan-du lese-avisen-mens-du-kjorer-til-jobb/275604>. Retrieved: 31.05.2017.
- Teknisk Ukeblad, . (2017). Tyskland godkjenner selvkjørende biler. <https://www.tu.no/>



- artikler/tyskland-godkjenner-selvkjorende-biler/383039#cxrecs\_s. Retrieved: 31.05.2017.
- Thomas, G., Tomic, P., and Tuite, A. (2007). High-speed catamaran or monohull? how do you choose? *Ships and Offshore Structures*, 2(2):137–147.
- Torqueedo (2017a). Electric boating - product catalogue. <http://media.torqueedo.com/catalogs/torqueedo-catalog-2017-en.pdf>. Retrieved: 23.05.2017.
- Torqueedo (2017b). Torqueedo service centres. <http://www.torqueedo.com/en/stores?service=true>. Retrieved: 09.05.2017.
- United States Department Of Transport, . (2017). Automated vehicle research. [https://www.its.dot.gov/automated\\_vehicle/](https://www.its.dot.gov/automated_vehicle/). Retrieved : 06.03.2017.
- University of Colorado, . (2017). Battery-powered systems: Efficiency, control, economics. [http://ecee.colorado.edu/~ecen2060/materials/lecture\\_notes/Battery3.pdf](http://ecee.colorado.edu/~ecen2060/materials/lecture_notes/Battery3.pdf). Retrieved:19.05.2017.
- Vargel, C. (2004). *Corrosion of Aluminium.*, volume 1st ed. Elsevier Science.
- Velodyne Lidar, . (2017). Puck vlc-16. <http://velodynelidar.com/vlp-16.html>. Retrieved: 23.05.2017.
- Wartsila (2014). Improving efficiency. <http://www.wartsila.com/sustainability/environmental-responsibility/products-and-environmental-aspects/improving-efficiency>. Retrieved: 19.05.2017.
- Wartsila (2017). One sea - autonomous maritime ecosystem introduced roadmaps to autonomous shipping. <https://www.wartsila.com/media/news/22-05-2017-one-sea-autonomous-maritime-ecosystem-introduced-roadmaps-to-autonomous-shipping>. Retrieved: 05.06.2017.
- Xylem Water Solutions, . (2017). Rule 1500 submersible. <https://www.jabscoshop.com/marine/pumps/rule-submersible-pumps-accessories/rule-bilge-pumps/03-rule-1500-submersible.htm>. Retrieved: 02.05.2017.
- Yeomans, G. (2014). Autonomous vehicles; handing over control: Opportunities and risks for insurance. <https://www.lloyds.com/~media/lloyds/reports/>

emerging%20risk%20reports/autonomous%20vehicles%20final.pdf. Retrieved :  
02.03.17.

## A Appendix: Design Log

| Date       | Decision                                  | Description  | Valid?             |
|------------|---|--|--------------------|
|            |   |  | OK                 |
|            |   |  | Not Valid any more |
| 01.01.2017 | Gangway and elevator for entrance to dock | Determined in project thesis   |                    |
| 20.01.2017 | Autonomous navigation                     | Defined by the mission statement   |                    |
| 20.01.2017 | Max 12 passengers                         | More than 12 passengers = passengers ship  |                    |
| 20.01.2017 | Emergency stop button                     | For passengers in case of emergency  |                    |
| 30.01.2017 | Electrical drive                          | More environmental friendly  |                    |
| 31.01.2017 | Podded propulsion(Azimuth or pod)         | Better maneuverability than conventional propellers  |                    |
| 02.02.2017 | Emergency ladder                          | Two outside hull for MOB   |                    |
| 02.02.2017 | Fenc around dock                          | Prevent MOB  |                    |
| 02.02.2017 | sensor placement                          | Unaccessible for passengers  |                    |
| 02.02.2017 | Tracker on ferry                          | Prevent theft  |                    |
| 02.02.2017 | Extra fire extinguisher                   | More than one  |                    |
| 02.02.2017 | Heat cables                               | In dock floor  |                    |
| 05.02.2017 | Building material                         | Aluminium - reduce fire risk compared to fibre glass.  |                    |
| 10.02.2017 | Docking using ramp                        | Best option in ranking. The ramp will hold the vessel in place at the dock + function as route on/off the ferry.               |                    |
| 17.02.2017 | Area requirement person                   | $0,38*0,63 = 0,3m^2$ (rounded up), Based on width of a lady with shopping bag, and "depth" of a man. (Measures from Byggforsk) |                    |
| 17.02.2017 | Area requirement wheelchair               | $0,78*1,40 = 1,1 m^2$ (rounded up), Based on biggest electric wheelchair. (Measures from Byggforsk)                            |                    |
| 17.02.2017 | Area requirement stroller                 | $0,65*1,15 = 0,75 m^2$ (rounded up), Breadth between 0,6 and 0,85. (Measures from Byggforsk)                                   |                    |
| 17.02.2017 | Area requirement for bicycle              | $0,7 * 1,8 = 1,26 m^2$ (Measures from byggforsk)   |                    |
| 17.02.2017 | Area requirement dog                      | $0,85*0,4 = 0,34 m^2$ , assume similar breadth as human  |                    |
| 21.02.2017 | One person is assumed to weigh 75 kg      | Nordic Boat Standard   |                    |
| 21.02.2017 | Seat set to 1 x 0,7 m2                    | Based on woman sat in chair and Byggforsk  |                    |
| 21.02.2017 | Monohull                                  | Determined through ranking, see ranking  |                    |
| 21.02.2017 | 2 thrusters                               |  |                    |
| 21.02.2017 | Azimuth thruster                          | The engine is inside the hull. Makes the pod smaller.  |                    |
| 21.02.2017 | Vessel size                               | 8 x 4 meters   |                    |
| 21.02.2017 | Docking front in                          | Two openings, one in each end. This gives the best flow through the ferry.   |                    |
| 21.02.2017 | Open superstructure with roof             | Determined through ranking. Best option.   |                    |
| 21.02.2017 | Thruster and battery                      | Assume that torqeedo cruise 4.0 is sufficient. Used in SBS   |                    |
| 21.02.2017 | Thruster and battery                      | Assume that torqeedo cruise 10.0 is sufficient. Used in  |                    |
| 24.02.2017 | Input power propeller                     | 2.5 kW - Torqeedo 10.0 FP  |                    |
| 24.02.2017 | Range before charge                       | 4.2 h pr pod   |                    |
| 24.02.2017 | Number of batterier                       | 10 units. Torqeedo power pack  |                    |
| 24.02.2017 | Total installed power                     | 26. 85 kWh   |                    |
| 24.02.2017 | Height inside ferry                       | 2.4 m height under roof inside ferry   |                    |
| 24.02.2017 | Weight bicycle                            | 18 kg excl. Person   |                    |

|            |                                   |   |  |
|------------|-----------------------------------|---|--|
| 24.02.2017 | weight stroller                   | 25 kg, including baby inside  |  |
| 24.02.2017 | Weight wheelchair                 | 225 kg, including person  |  |
| 24.02.2017 | Weight dog                        | 15 kg excl person   |  |
| 24.02.2017 | CO2 for firefighting              | Less risk of damaging equipment   |  |
| 27.02.2017 | Sensors                           | 0.008 m2 unit area, 2 units in total  |  |
| 27.02.2017 | cable storage                     | 0.150 m2 unit area, 2 units in total  |  |
| 27.02.2017 | computer                          | 1.2 m2 unit area, 1 unit in total   |  |
| 27.02.2017 | surveillance                      | 0.035 m2 unit area, 2 units in total  |  |
| 28.02.2017 | air vent                          | 0.035 m2 unit area, 2 units in total  |  |
| 28.02.2017 | ramp                              | 0.075 m2 unit area, 2 units in total  |  |
| 28.02.2017 | hydraulic cylinder                | 0.044 m2 unit area, 4 units in total  |  |
| 28.02.2017 | info screen                       | 0.028 m2 unit area, 2 units in total  |  |
| 28.02.2017 | life vest child                   | 0.18 m2 unit area, 12 units in total  |  |
| 28.02.2017 | life vest adult                   | 0.23 m2 unit area, 12 units in total  |  |
| 28.02.2017 | fire monitors                     | 0.0001 m2 unit area, 4 units in total   |  |
| 28.02.2017 | fire extinguisher                 | 0.02 m2 unit area, 2 units in total   |  |
| 28.02.2017 | life buoy                         | 0.44 m2 unit area, 2 units in total   |  |
| 28.02.2017 | Lounge space                      | 0.4 m2/seat. Gives total of 0.7 m2/pass combined with the unit area per person  |  |
| 28.02.2017 | Main dimensions                   | LOA = 8.1 m and B = 4 m   |  |
| 10.03.2017 | Ramp for boarding                 | 30 kg unit weight   |  |
| 10.03.2017 | Fence                             | 30 kg unit weight   |  |
| 10.03.2017 | Superstructure                    | 450 kg unit weight  |  |
| 10.03.2017 | Ship outfitting                   | 184 kg unit weight  |  |
| 10.03.2017 | Hull weight                       | 400 kg  |  |
| 12.03.2017 | Emergency ladder                  | Integrated in hull  |  |
| 27.03.2017 | Passenger registration            | System on land should register number of passengers and secure their safety. May use EIT report for inspiration on design |  |
| 01.04.2017 | Battery                           | 24.3 kg unit weight (Torqeedo power pack)   |  |
| 01.04.2017 | CO2 tank                          | 19 kg unit weight   |  |
| 01.04.2017 | Extra bilge pump                  | 1.5 kg unit weight  |  |
| 02.04.2017 | Thruster system                   | 50 kg unit weight   |  |
| 02.04.2017 | CO2 fire system                   | 25 kg unit weight   |  |
| 04.04.2017 | Hull structure                    | 1501 kg unit weight   |  |
| 04.04.2017 | Hydr. Aggr. Incl oil              | 30 kg unit weight   |  |
| 04.04.2017 | Bilge pump                        | 1.5 kg unit weight  |  |
| 04.04.2017 | Safety/ Rescue equipment          | 41 kg unit weight   |  |
| 04.04.2017 | Main Deck                         | 415 kg unit weight  |  |
| 06.04.2017 | Operational speed                 | 4 knots - 5 knot limitation in channel  |  |
| 06.04.2017 | Max speed                         | 5 knots   |  |
| 18.04.2017 | Plate thickness                   | Determined by Nordisk båtstandard. See own document. All numbers are rounded up to closest mm                             |  |
| 19.04.2017 | Sensors                           | 0.008 m2 unit area, 6 units in total  |  |
| 20.04.2017 | Wind speeds for analysis in Delft | 18.5 m/s  |  |
| 20.04.2017 | Heat cables                       | In ferry deck and ferry roof  |  |
| 24.04.2017 | INERGEN for fire extinguishing    | Safer for people in the room. Better alternative according to people at PBES. More info needed                            |  |

|            |                                    |  |  |
|------------|------------------------------------|--|--|
| 25.04.2017 | Longer mid-ship                    | More space required on main deck. The ship is made 0.9 m longer giving LOA= 9 m. B = 4 m                                   |  |
| 25.04.2017 | Ramp for boarding                  | 126 kg unit weight   |  |
| 25.04.2017 | Fence                              | 129 kg unit weight   |  |
| 25.04.2017 | Superstructure                     | 1084 kg unit weight  |  |
| 25.04.2017 | Input power propeller              | 4.2 kW at 4 knots  |  |
| 25.04.2017 | Range before charge                | 6.2 h pr pod/module  |  |
| 25.04.2017 | Number of batterier                | 2 PBES modules   |  |
| 25.04.2017 | Total installed power              | 52 kWh   |  |
| 25.04.2017 | Hull weight incl strength elements | 1622 kg  |  |
| 25.04.2017 | Perpendiculars                     | 74 mm from each bow. Put where the bow meets the water line  |  |
| 25.04.2017 | Battery from PBES will be used.    | Unit weight 591 kg   |  |
| 26.04.2017 | Thrusters                          | Aquamot steerable azimuth pods x 2 (max input 10 870 W)  |  |
| 03.05.2017 | NOVEC for fire extinguishing       | Recommended by NORTRONIK. Samme funksjonalitet som inergen, men kan oppbevares under mindre trykk. Lettere å transportere. |  |
| 03.05.2017 | Anchor                             | 2 anchors, each 20 kg + winch. Autonomous deployment   |  |

## B Appendix: Formal Safety Assessment

### B.1 Notes from Preparation of PHA

#### Plan and prepare

##### Objective and boundary conditions

- The background for the risk analysis is to determine relevant risks so that they can be mitigated in the early design phases. This is because safety is a very important aspect for this project. It will be relevant for the question of insurance.
- The risk analysis should provide input to design decisions so that the design will have the lowest reasonably possible risk level.
- The analysis must provide information on possible hazards, hazardous events and their probability and consequence. This will give the complete risk picture for the system. The analysis will be of a more qualitative form, but quantitative information may be provided when available.
- Laws, regulations and standards provide the appropriate method for formal safety assessment (FSA). The team will use guidelines from IMO,+ specifically made for maritime safety. (?)
- The results from the analysis needs to be available at an early stage in the design process. This because the results from the analysis are to be used in the further design.
- The stakeholders include the design team, the project manager and the Norwegian Maritime Authority (NMA).
- The design team are the only stakeholder involved in the design of the system. The project manager have set certain demands for the design.
- No risk acceptance criteria is established. This is to be determined by the design team and will most likely be ALARP.
- The overall safety objective is to have a level of safety for the passengers as high as possible.

##### Study team, quality insurance and involvement

- Only the team members will contribute to the analysis. No external team
- The analysis require a good understanding of the system and possible hazards. It would also be helpful to have understanding of the electrical and autonomous system.
- The quality of the work will be controlled by the teams risk supervisor and the NMA
- Stakeholders will be informed through meetings and e-mail communication.

##### Analytical approach

- The approach to the analysis will be to follow the FSA methodic. The team will look at possible hazards and their hazardous events. The probability and consequence of each events will be determined and risk mitigating options are suggested. These are evaluated using cost benefit analysis. Further, an event tree will look at some of the possible combined risks to find mitigation options for these. FTA may also be relevant.
- This approach will look at both individual risks and combined risks. It will thus be responsive to the decision needs.

#### Background information

- There are no identical cases to relate to as no autonomous ferries exist. There are still a lot of research from the car industry relating to autonomous vehicle risks.
- There was a case with a cable ferry that capsized due to too many passengers on board. One person was severely injured and the owners were forced to pay compensation. There also exists accident reports of autonomous cars. One example is a Tesla that crashed in the US in 2016 because the car's system was unable to register a meeting vehicle (Klein, 2016). Another example is the Google car that crashed with another car that was running a red light (Curtis, 2016)
- Generally, some risk is accepted as long as it does not endanger the passengers or other people nearby. Risk to the ferry itself is less severe.

## B.2 Mindmaps from Brainstorming for Risk Assessment

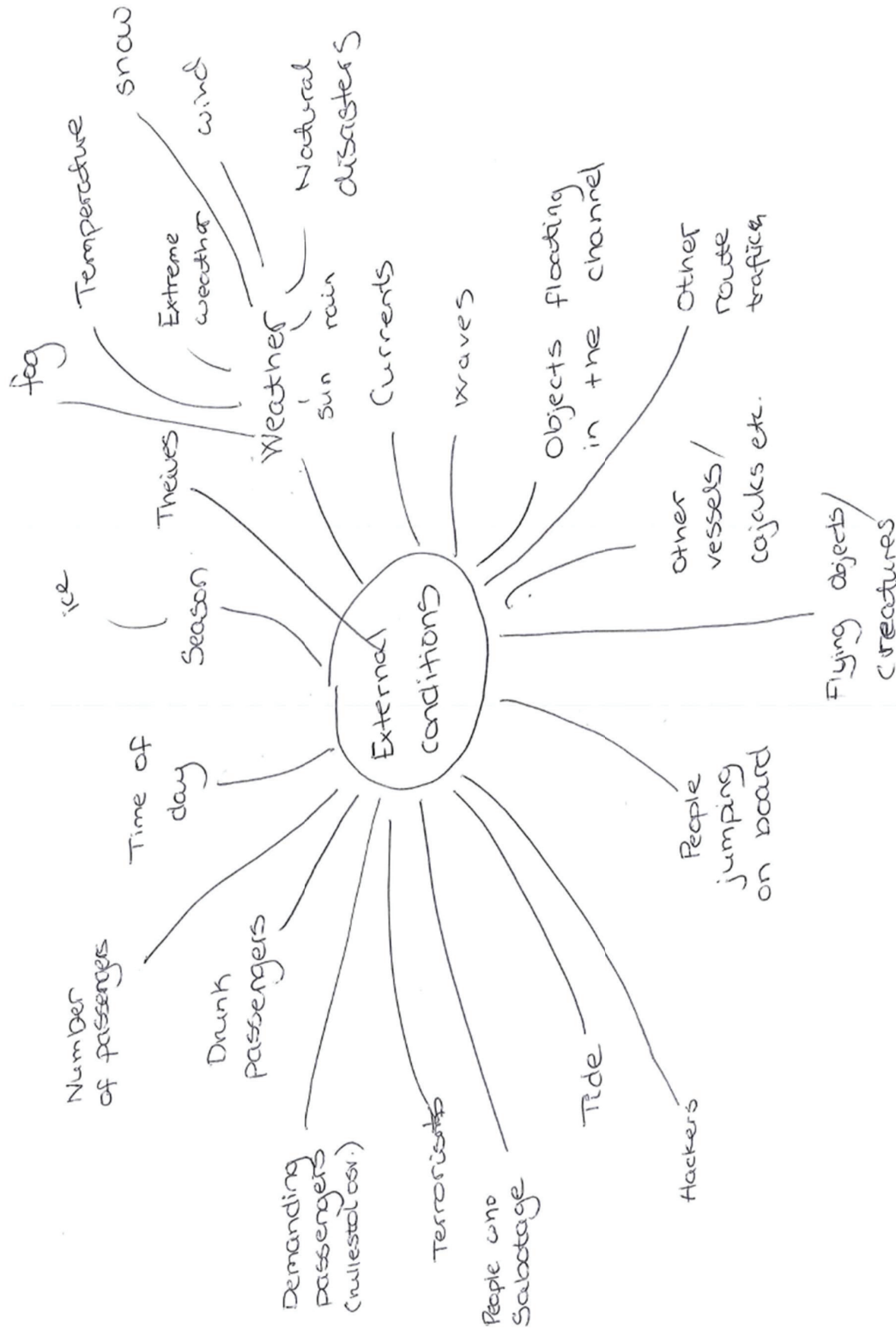



System  
Functional  
Mechanical

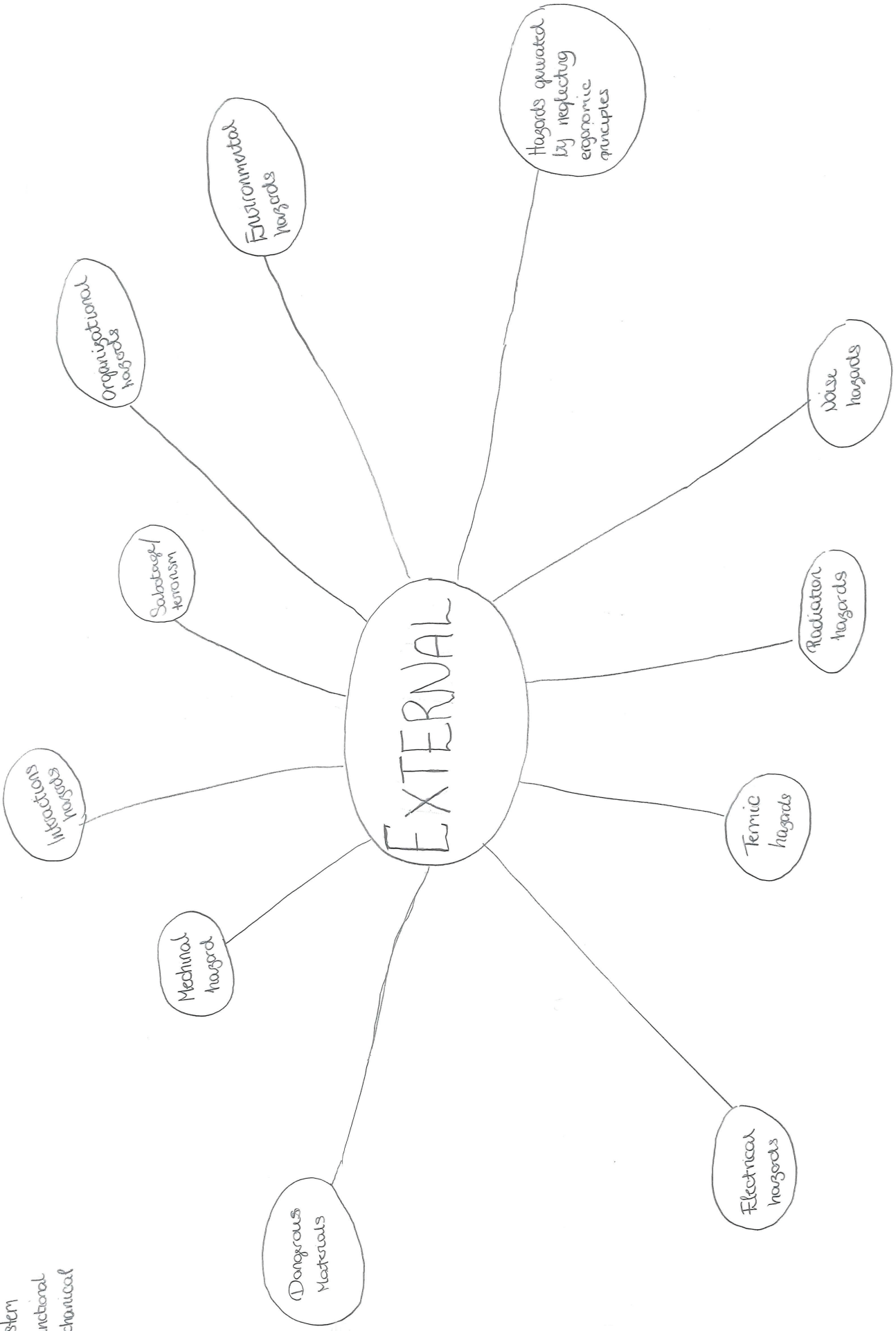

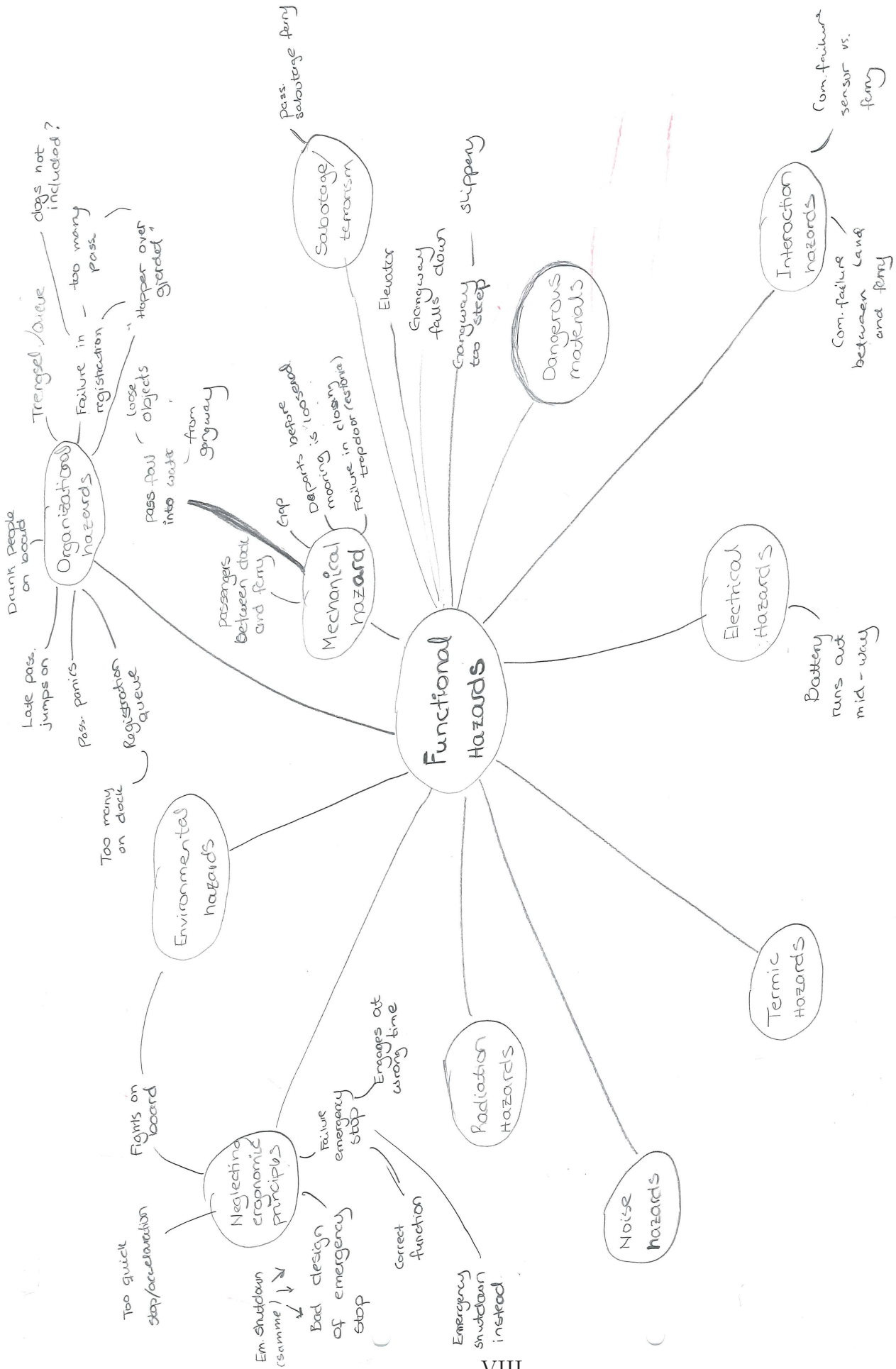

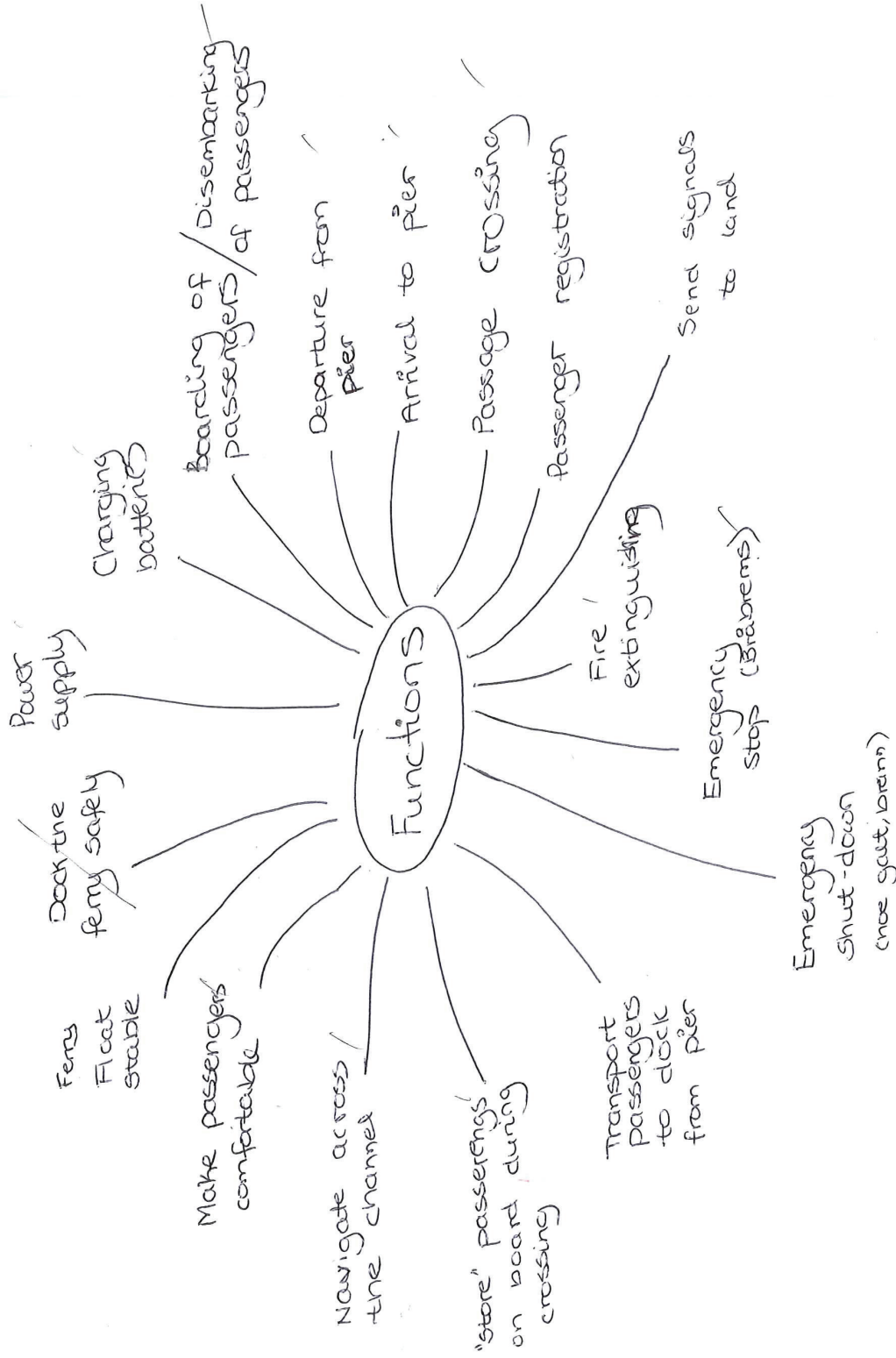

# System Hazards

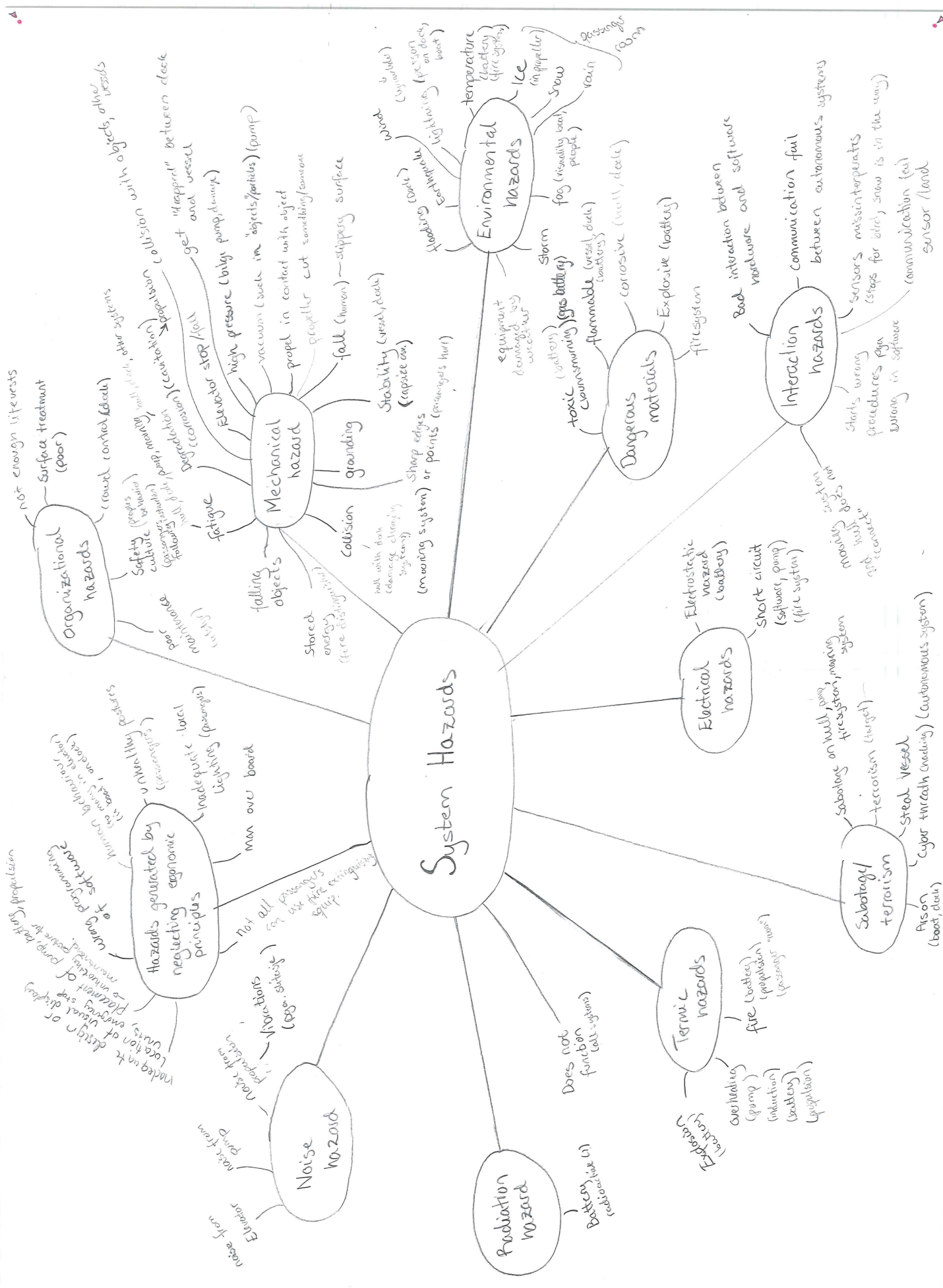

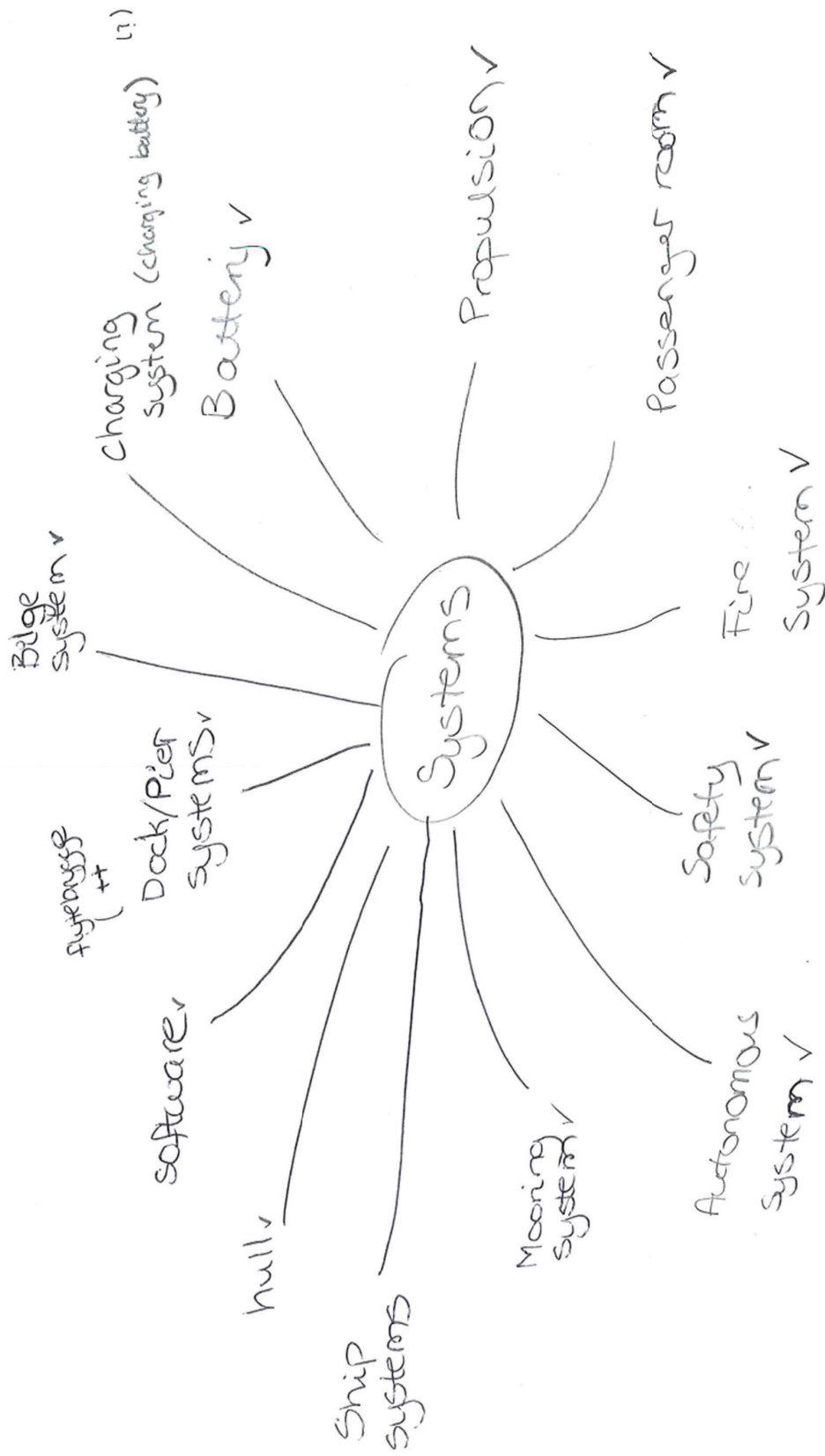

## B.3 Fault Tree Analysis

### Emergency Stop Failure

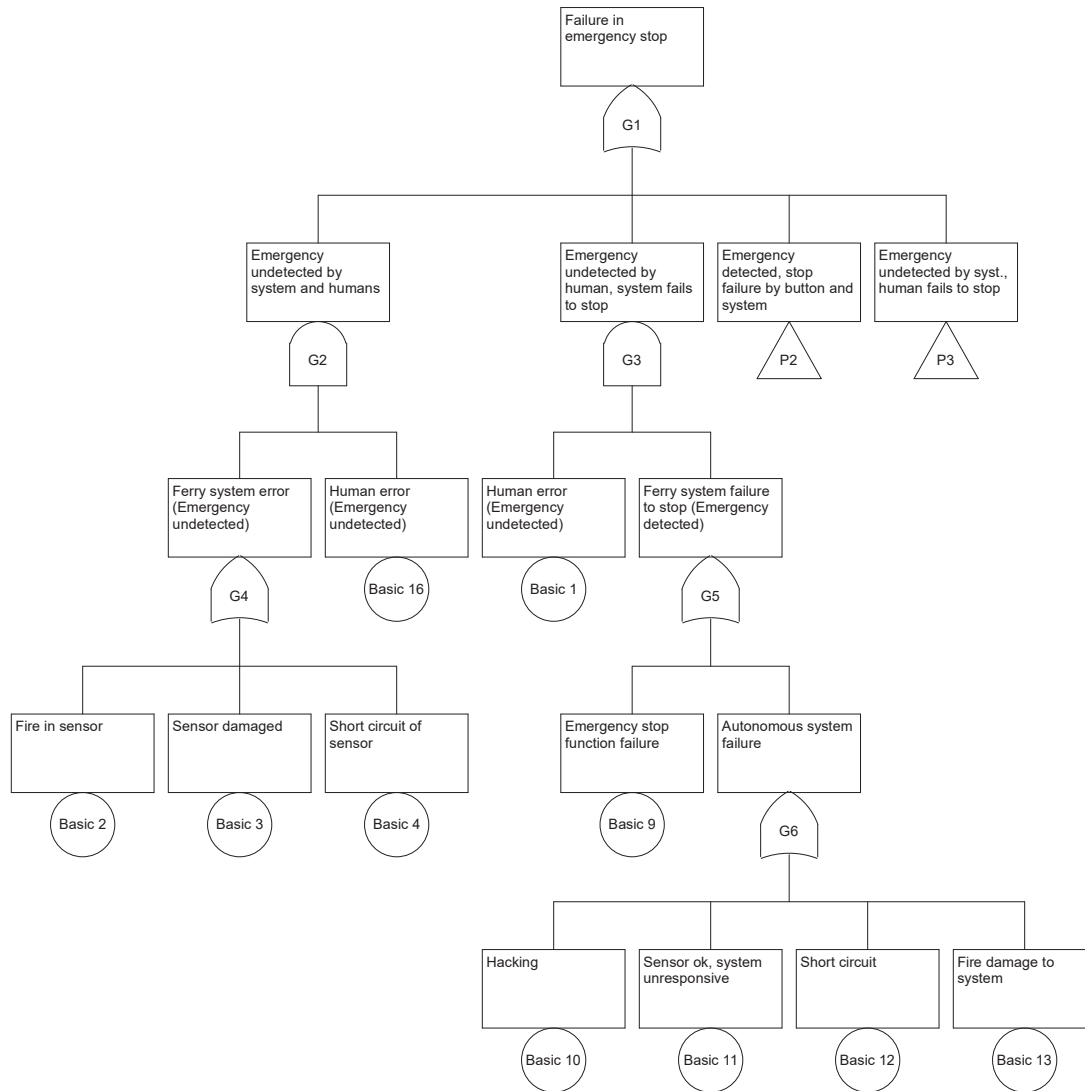

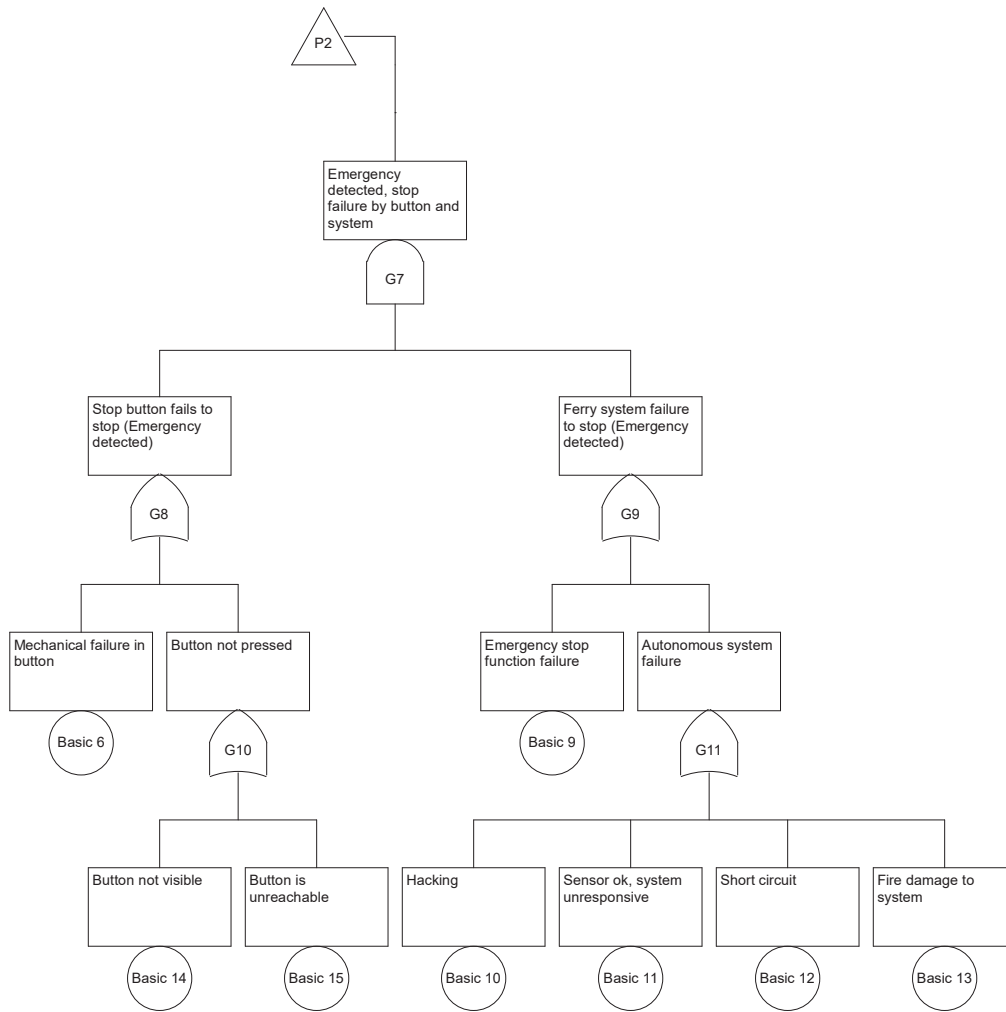

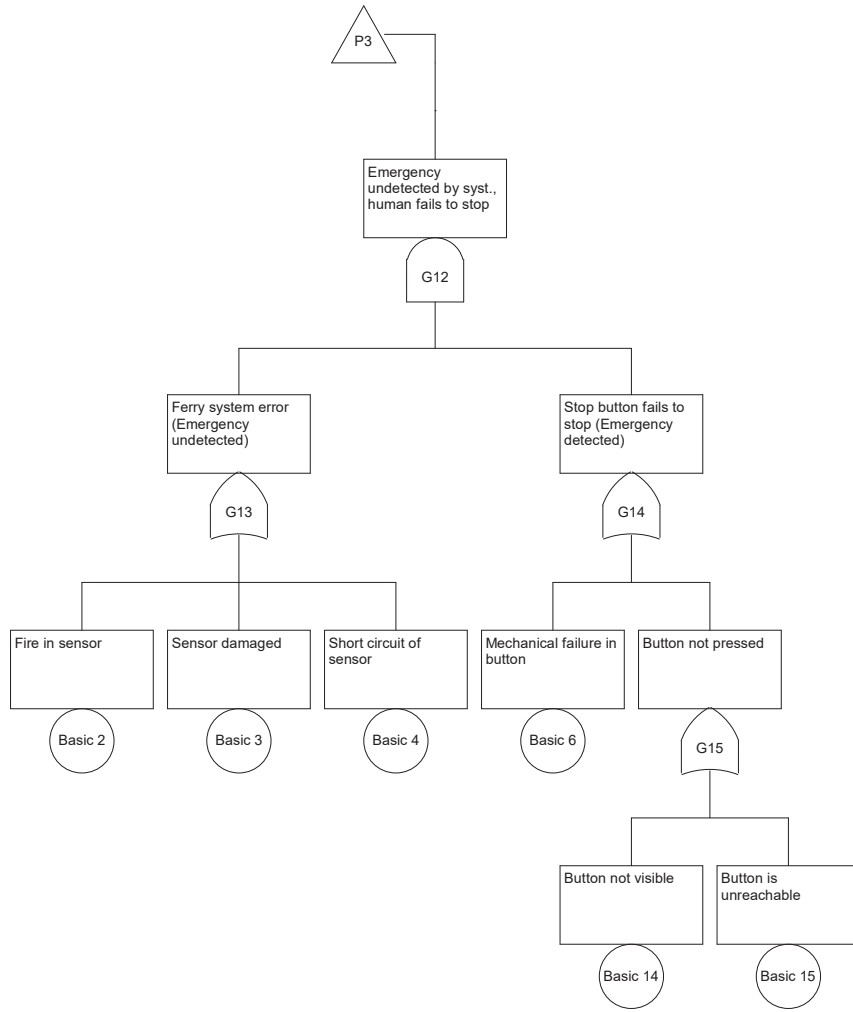



# Failure in Registration of Passengers

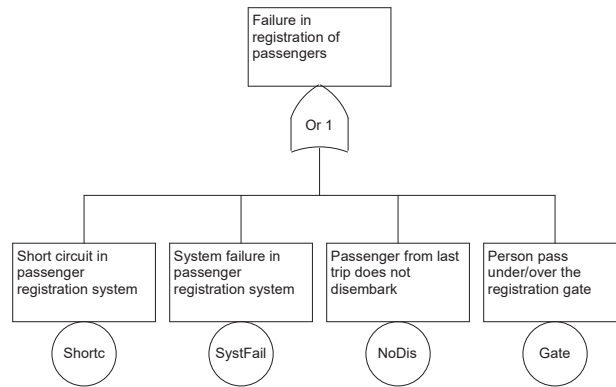

# Fire on Vessel

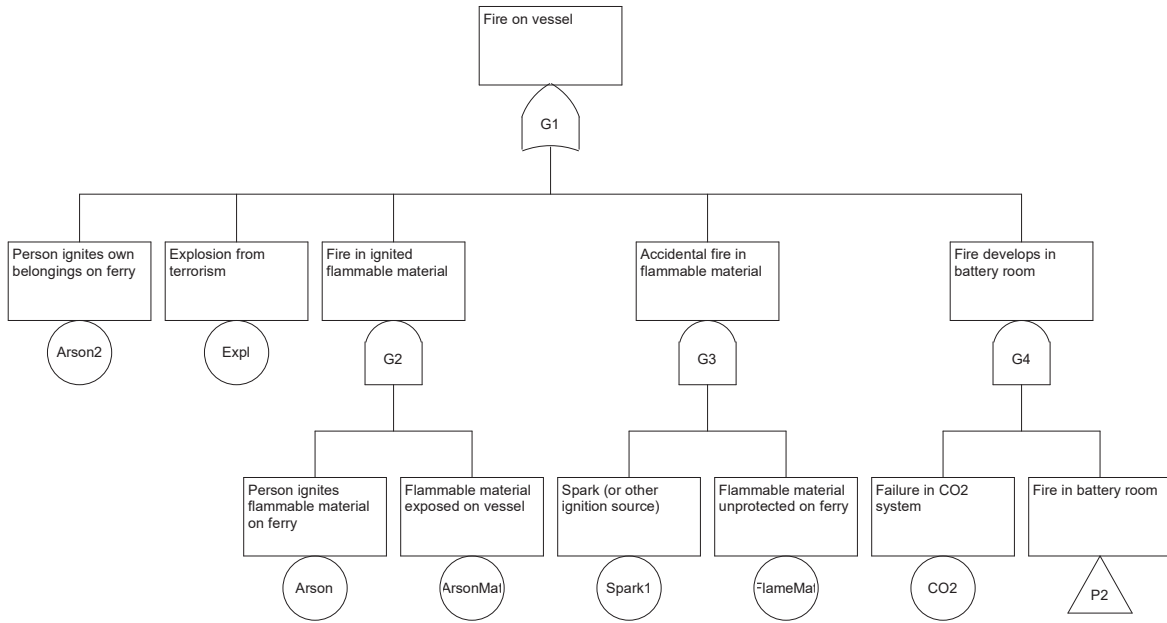

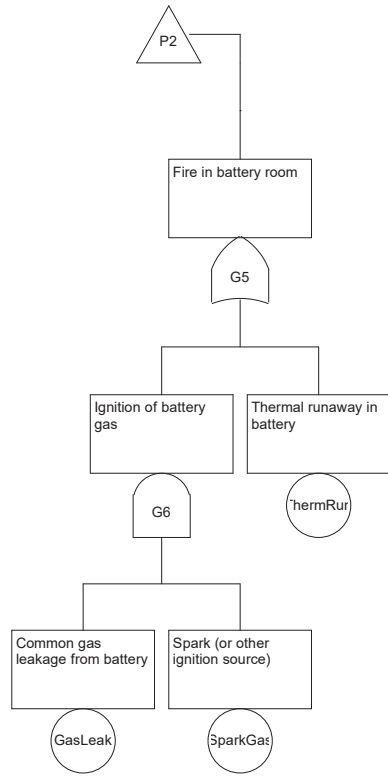

# Loss of Navigational Control

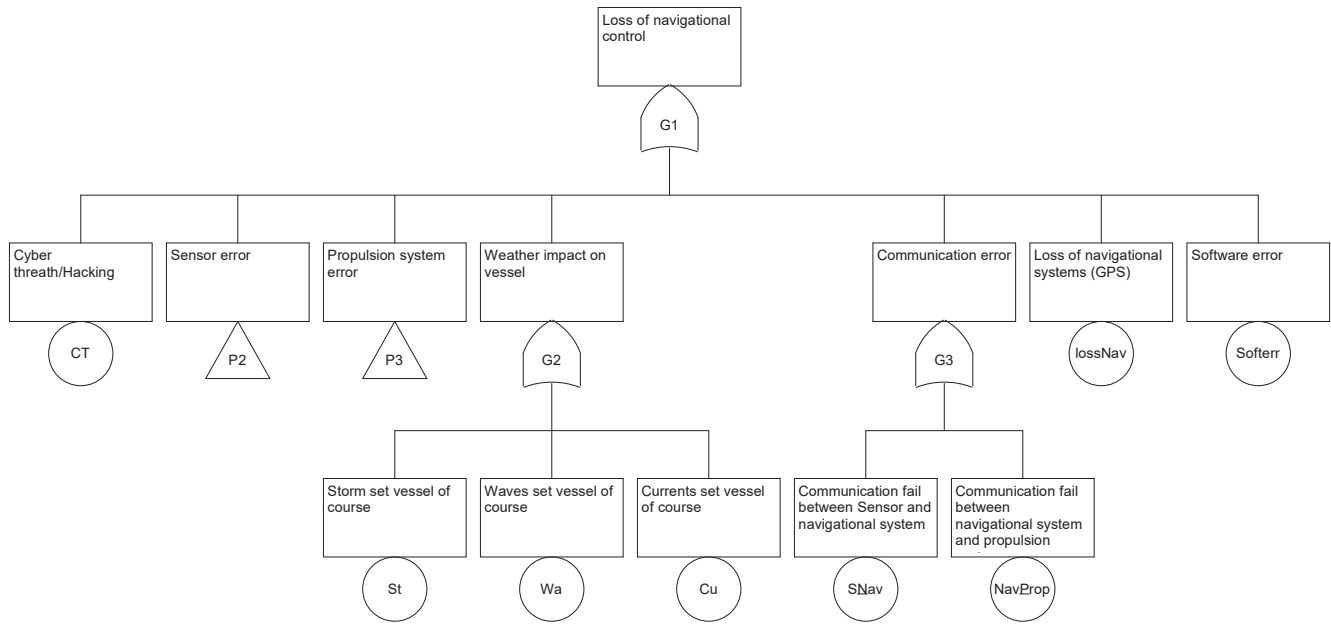

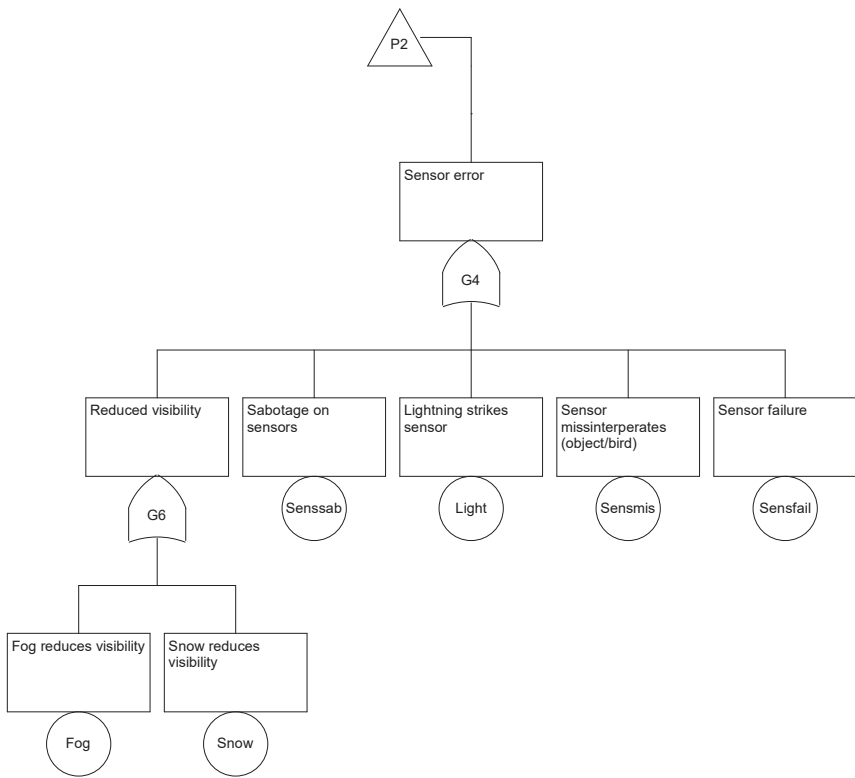

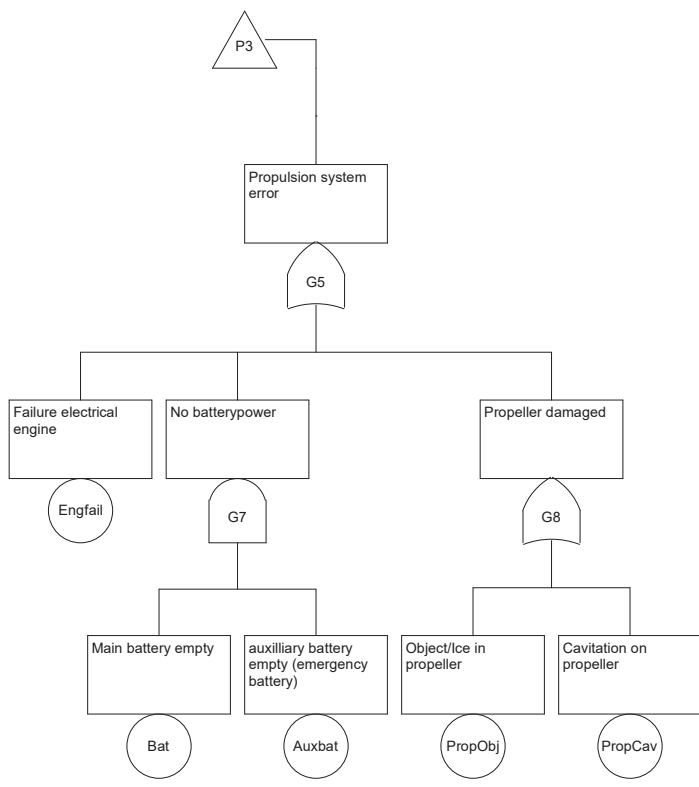

# Not Enough Life Jackets

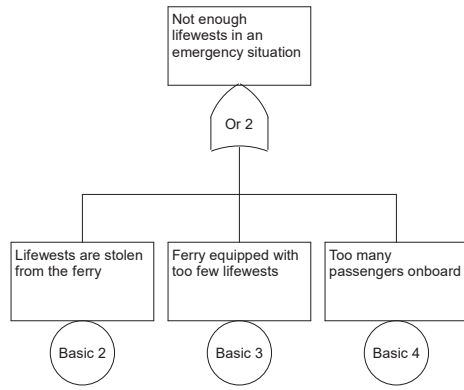

# Person in Water

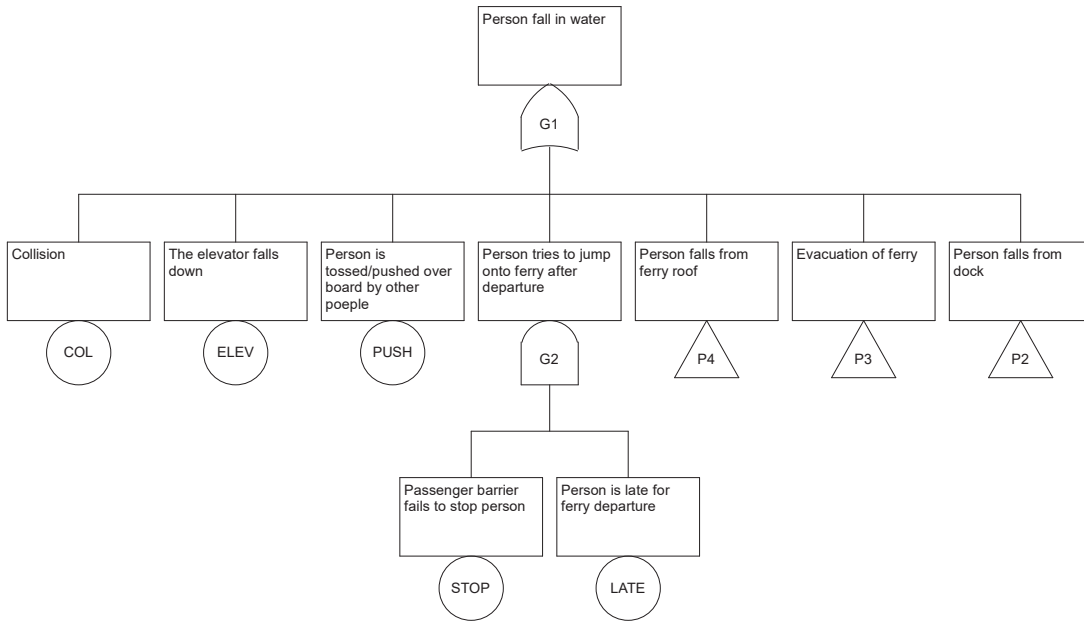



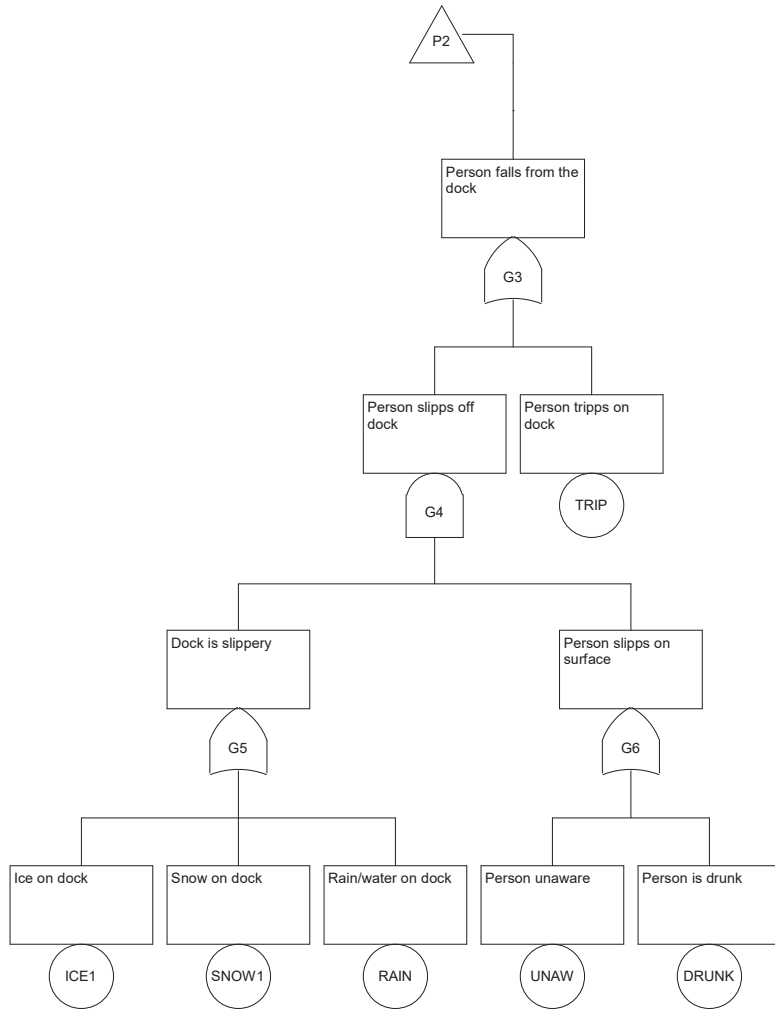

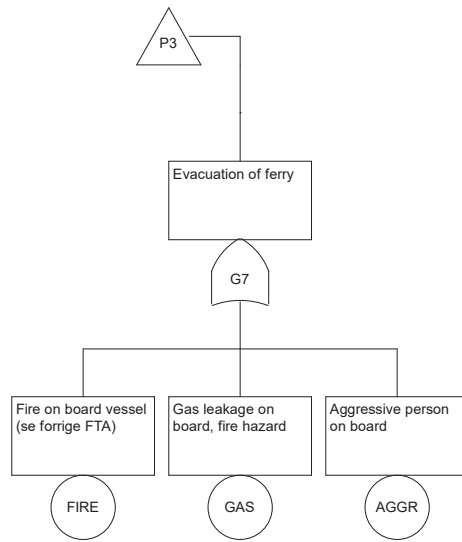

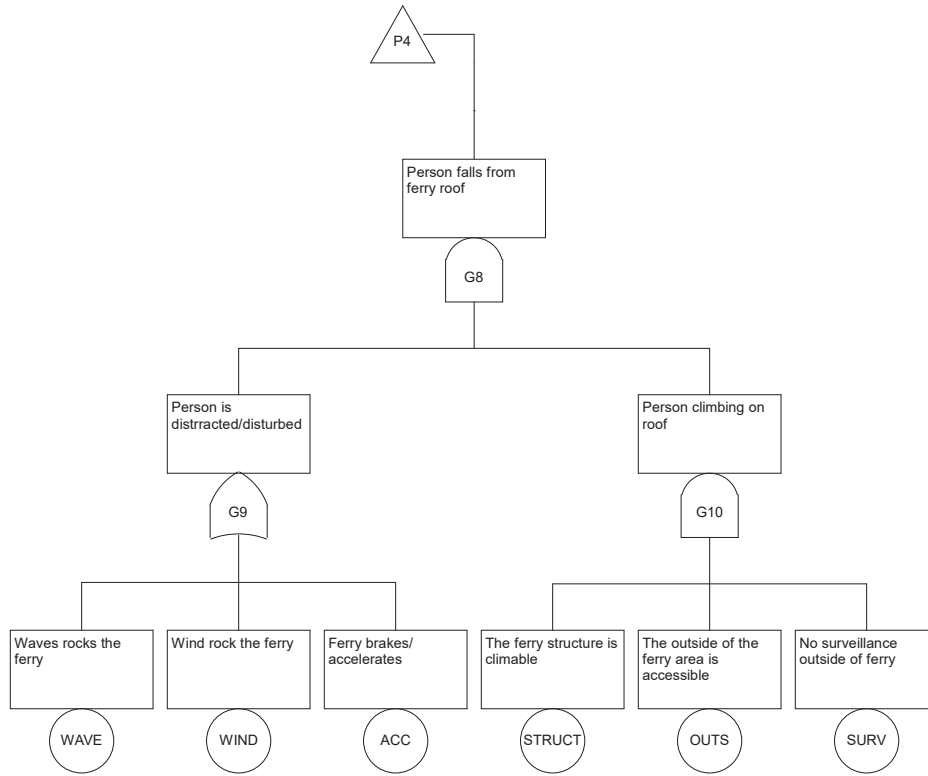

# Slippery Dock

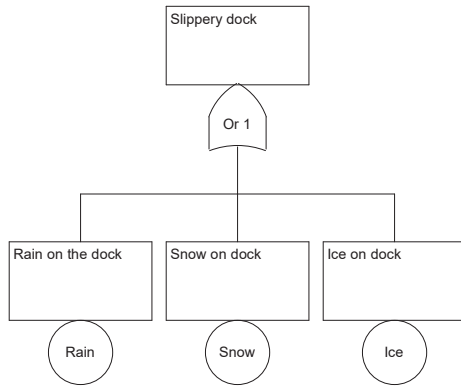

# Vessel Stolen

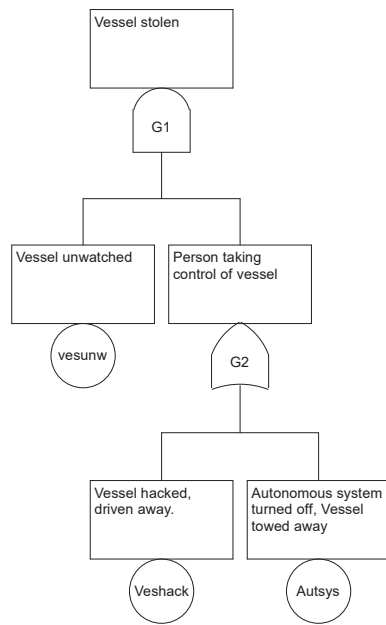

## B.4 FTA - Values for Basic Events

| Basic event                                   | Probability | Category   |
|---|-------------|------------|
| Cyber threath                                 | 0.007       | Possible   |
| Software error                                | 0.004       | Remote     |
| Loss of navigational system                   | 0.003       | Remote     |
| Communication error, nav system and sensor    | 0.004       | Remote     |
| Communication error, nav system and propeller | 0.004       | Remote     |
| Storm   | 0.01        | Possible   |
| Waves   | 0.01        | Possible   |
| Currents                                      | 0.02        | Possible   |
| Fog   | 0.1         | Occasional |
| Snow  | 0.15        | Occasional |
| Sabotage sensor                               | 0.07        | Possible   |
| Lightning strikes sensor                      | 0.002       | Remote     |
| Sensor missinterperates                       | 0.05        | Possible   |
| Sensor failure                                | 0.04        | Possible   |
| Failure electrical engine                     | 0.005       | Remote     |
| Main battery empty                            | 0.02        | Possible   |
| Auxillary battery empty                       | 0.004       | Remote     |
| Object/ice in propeller                       | 0.1         | Occasional |
| Cavitation Propeller                          | 0.007       | Possible   |

| Basic event    | Probability | Category      |
|----------------|-------------|---------------|
| Rain on dock   | 0.5         | Fairly Normal |
| Snow uncleared | 0.2         | Occasional    |
| Ice uncleared  | 0.3         | Occasional    |

| Basic event                  | Probability | Category   |
|------------------------------|-------------|------------|
| Vessel unwatched             | 0.5         | Occasional |
| Vessel hacked                | 0.007       | Possible   |
| Autonomous system turned off | 0.003       | remote     |

| Basic event                          | Probability | Category |
|--------------------------------------|-------------|----------|
| Lifewests stolen from ferry          | 0.1         | Possible |
| Ferry equipped with to few lifewests | 0.005       | Remote   |
| Too many passengers on board         | 0.1         | Possible |

| Basic event                                     | Probability | Category   |
|---|-------------|------------|
| Short circuit in passenger registration         | 0.05        | Possible   |
| System failure in passenger registration system | 0.05        | Possible   |
| Passenger from last trip did not disembark      | 0.4         | Occasional |
| Person pass over/under the registration gate    | 0.3         | Occasional |

| Basic event                                | Probability | Category   |
|--|-------------|------------|
| Person ignites own belongings on ferry     | 0.1         | Possible   |
| Explosion because of terrorism             | 0.002       | Remote     |
| Person ignites flammable material on ferry | 0.075       | Possible   |
| Flammable material exposed on ferry        | 0.2         | Occasional |
| Spark (or other ignition source)           | 0.05        | Possible   |
| Failure in CO <sub>2</sub> system          | 0.05        | Possible   |
| Thermal runaway in battery                 | 0.1         | Possible   |
| Gas leakage from battery                   | 0.4         | Occasional |

| Basic event                              | Probability | Category      |
|--|-------------|---------------|
| Collision                                | 0.1         | Possible      |
| The elevator falls down                  | 0.002       | Remote        |
| Person tossed/Pushed over board          | 0.075       | Possible      |
| Passenger barrier fails to stop person   | 0.4         | Occasional    |
| Person is late for ferry departure       | 0.3         | Occasional    |
| Person trips on dock                     | 0.2         | Occasional    |
| Ice on dock                              | 0.3         | Occasional    |
| Snow on dock                             | 0.2         | Occasional    |
| Rain/water on dock                       | 0.5         | Fairly normal |
| Person unaware                           | 0.3         | Occasional    |
| Person is drunk                          | 0.3         | Occasional    |
| Fire on board vessel                     | 0.13        | Occasional    |
| Gas leakage on board, fire hazard        | 0.005       | Remote        |
| Aggressive person on board               | 0.2         | Occasional    |
| Waves rock the ferry                     | 0.01        | Possible      |
| Wind rock the ferry                      | 0.01        | Possible      |
| Ferry brakes/accelerates                 | 0.2         | Occasional    |
| The ferry structure is climbable         | 0.1         | Possible      |
| The outside of the ferry area accessible | 0.4         | Occasional    |
| No surveillance outside of ferry         | 0.1         | Possible      |

| Basic event                          | Probability | Category      |
|--------------------------------------|-------------|---------------|
| Human error(do not detect emergency) | 0.05        | Possible      |
| Human detection                      | 0.95        | Fairly normal |
| Emergency stop function failure      | 0.005       | Remote        |
| Fire                                 | 0.13        | Occasional    |
| System failure                       | 0.005       | Remote        |
| Short circuit system                 | 0.05        | Possible      |
| Mechanical failure, button           | 0.006       | Possible      |
| Hacking                              | 0.007       | Possible      |
| Sensor is ok, system unresponsive    | 0.01        | Possible      |
| Fire damage system                   | 0.13        | Occasional    |
| Button not visible                   | 0.003       | Remote        |
| Button is unreachable                | 0.01        | Possible      |

## B.5 Cost Benefit Analysis

### **Cost Benefit Analysis**

|                      |   |           |
|----------------------|---|-----------|
| Interest rate        | i | 5 %       |
| Expected lifetime    | n | 15        |
| Present value factor |   | 10.379658 |

#### **HEAT CABLES**

##### **Normal floor on dock**

|                               |    |                 |
|-------------------------------|----|-----------------|
| Probability of accident       | P0 | 0.006           |
| Consequence, Cost of accident | C0 | 76235444 kr     |
| Cost of risk                  | R0 | 457413 Per year |

##### **Heat cables in floor**

|                               |    |             |
|-------------------------------|----|-------------|
| Reduction in probability      |    | 75 %        |
| New probability               | P1 | 0.0015      |
| Consequence, Cost of accident | C1 | 76235444 kr |
| Risk                          | R1 | 114353      |

|                            |            |                         |
|----------------------------|------------|-------------------------|
| Increase in operation cost | Opex       | 10000                   |
| Investment                 | Capex      | 65960                   |
| Reduced risk               | $\Delta R$ | 343059                  |
| Present value of cost      | Pc         | 169756.58               |
| Present value of benefit   | Pb         | 3560840.26              |
| <b>Cost-benefit ratio</b>  | <b>C/B</b> | <b>0.04767318 &lt;1</b> |
|                            |            | <b>Cost Beneficial</b>  |

#### **PERSON TO CLEAR DOCK**

##### **Normal floor on dock, no clearing**

|                               |    |                 |
|-------------------------------|----|-----------------|
| Probability of accident       | P0 | 0.006           |
| Consequence, Cost of accident | C0 | 76235444 kr     |
| Cost of risk                  | R0 | 457413 Per year |

##### **Person hired to clear dock**

|                               |    |             |
|-------------------------------|----|-------------|
| Reduction in probability      |    | 37.5 %      |
| New probability               | P1 | 0.00375     |
| Consequence, Cost of accident | C1 | 76235444 kr |
| Risk                          | R1 | 285883      |

|                            |            |                        |
|----------------------------|------------|------------------------|
| Increase in operation cost | Opex       | 27000 Per year         |
| Investment                 | Capex      | 0                      |
| Reduced risk               | $\Delta R$ | 171530                 |
| Present value of cost      | Pc         | 280250.767             |
| Present value of benefit   | Pb         | 1780420.13             |
| <b>Cost-benefit ratio</b>  | <b>C/B</b> | <b>0.1574071 &lt;1</b> |
|                            |            | <b>Cost Beneficial</b> |



## FENCING AROUND DOCK

### No fencing around dock

|                               |    |                 |
|-------------------------------|----|-----------------|
| Probability of accident       | P0 | 0.006           |
| Consequence, Cost of accident | C0 | 76235444 kr     |
| Cost of risk                  | R0 | 457413 Per year |

### Fencing around dock

|                               |    |             |
|-------------------------------|----|-------------|
| Reduction in probability      |    | 90.0 %      |
| New probability               | P1 | 0.0006      |
| Consequence, Cost of accident | C1 | 76235444 kr |
| Risk                          | R1 | 45741       |

|                            |            |                         |
|----------------------------|------------|-------------------------|
| Increase in operation cost | Opex       | 0                       |
| Investment                 | Capex      | 5000                    |
| Reduced risk               | $\Delta R$ | 411671                  |
| Present value of cost      | Pc         | 5000                    |
| Present value of benefit   | Pb         | 4273008.31              |
| <b>Cost-benefit ratio</b>  | <b>C/B</b> | <b>0.00117014 &lt;1</b> |

*Cost Benefitial*

## Cost Benefit Analysis

|                      |   |           |
|----------------------|---|-----------|
| Interest rate        | i | 5 %       |
| Expected lifetime    | n | 15        |
| Present value factor |   | 10.379658 |

### TRACKER ON VESSEL

#### No tracker on vessel

|                               |    |                 |
|-------------------------------|----|-----------------|
| Probability of accident       | P0 | 0.1472          |
| Consequence, Cost of accident | C0 | 1500000 kr      |
| Cost of risk                  | R0 | 220800 Per year |

#### Tracker on vessel

|                               |    |            |
|-------------------------------|----|------------|
| Reduction in probability      |    | 50 %       |
| New probability               | P1 | 0.0736     |
| Consequence, Cost of accident | C1 | 1500000 kr |
| Risk                          | R1 | 110400     |

|                            |            |                         |
|----------------------------|------------|-------------------------|
| Increase in operation cost | Opex       | 0                       |
| Investment                 | Capex      | 2000                    |
| Reduced risk               | $\Delta R$ | 110400                  |
| Present value of cost      | Pc         | 2000                    |
| Present value of benefit   | Pb         | 1145914.25              |
| <b>Cost-benefit ratio</b>  | <b>C/B</b> | <b>0.00174533 &lt;1</b> |
|                            |            | <b>Cost Benefitial</b>  |

### PERSON WATCHING THE FERRY

#### No person watching the ferry

|                               |    |               |
|-------------------------------|----|---------------|
| Frequency of accident         | F0 | 0.00073445    |
| Consequence, Cost of accident | C0 | 1500000 kr    |
| Cost of risk                  | R0 | 1102 Per year |

#### Person watching the ferry

|                               |    |            |
|-------------------------------|----|------------|
| Reduction in Frequency        |    | 60 %       |
| New frequency                 | F1 | 0.00029378 |
| Consequence, Cost of accident | C1 | 1500000 kr |
| Risk                          | R1 | 441        |

|                            |            |                            |
|----------------------------|------------|----------------------------|
| Increase in operation cost | Opex       | 273750 Per year            |
| Investment                 | Capex      | 0                          |
| Reduced risk               | $\Delta R$ | 661                        |
| Present value of cost      | Pc         | 2841431.39                 |
| Present value of benefit   | Pb         | 6861.04696                 |
| <b>Cost-benefit ratio</b>  | <b>C/B</b> | <b>414.139621 &gt;1</b>    |
|                            |            | <b>NOT Cost Benefitial</b> |

## Cost Benefit Analysis

|                      |   |           |
|----------------------|---|-----------|
| Interest rate        | i | 5 %       |
| Expected lifetime    | n | 15        |
| Present value factor |   | 10.379658 |

### ADD LADDER/NET

#### No ladder/net on vessel

|                               |    |                  |
|-------------------------------|----|------------------|
| Probability of accident       | P0 | 0.0524619        |
| Consequence, Cost of accident | C0 | 76235444 kr      |
| Cost of risk                  | R0 | 3999456 Per year |

#### Ladder/net on vessel

|                               |    |             |
|-------------------------------|----|-------------|
| Reduction in probability      |    | 17 %        |
| New probability               | P1 | 0.04357095  |
| Consequence, Cost of accident | C1 | 76235444 kr |
| Risk                          | R1 | 3321651     |

|                            |            |                         |
|----------------------------|------------|-------------------------|
| Increase in operation cost | Opex       | 0                       |
| Investment                 | Capex      | 1000                    |
| Reduced risk               | $\Delta R$ | 677806                  |
| Present value of cost      | Pc         | 1000                    |
| Present value of benefit   | Pb         | 7035389.5               |
| <b>Cost-benefit ratio</b>  | <b>C/B</b> | <b>0.00014214 &lt;1</b> |

**Cost Benefitial**

### MAKING STRUCTURE UNCLIMBABLE

#### Structure climbable

|                               |    |                  |
|-------------------------------|----|------------------|
| Frequency of accident         | F0 | 0.04302718       |
| Consequence, Cost of accident | C0 | 76235444 kr      |
| Cost of risk                  | R0 | 3280196 Per year |

#### Structure unclimbable

|                               |    |             |
|-------------------------------|----|-------------|
| Reduction in frequency        |    | 0.0296 %    |
| New frequency                 | F1 | 0.04301445  |
| Consequence, Cost of accident | C1 | 76235444 kr |
| Risk                          | R1 | 3279226     |

|                            |            |                          |
|----------------------------|------------|--------------------------|
| Increase in operation cost | Opex       | 0                        |
| Investment                 | Capex      | 100000                   |
| Reduced risk               | $\Delta R$ | 970                      |
| Present value of cost      | Pc         | 100000                   |
| Present value of benefit   | Pb         | 10069.1067               |
| <b>Cost-benefit ratio</b>  | <b>C/B</b> | <b>9.93136759 &gt; 1</b> |

**NOT Cost Benefitial**

## Cost Benefit Analysis

|                      |   |           |
|----------------------|---|-----------|
| Interest rate        | i | 5 %       |
| Expected lifetime    | n | 15        |
| Present value factor |   | 10.379658 |

### IMPROVED DAMAGE STABILITY TO AVOID SINKING/CAPSIZING

#### Normal

|                               |    |               |
|-------------------------------|----|---------------|
| Probability of accident       | P0 | 0.0049792     |
| Consequence, Cost of accident | C0 | 1500000 kr    |
| Cost of risk                  | R0 | 7469 Per year |

#### Improved

|                               |    |            |
|-------------------------------|----|------------|
| Reduction in probability      |    | 80 %       |
| New probability               | P1 | 0.00099584 |
| Consequence, Cost of accident | C1 | 1500000 kr |
| Risk                          | R1 | 1494       |

|                            |            |                         |
|----------------------------|------------|-------------------------|
| Increase in operation cost | Opex       | 0                       |
| Investment                 | Capex      | 500000                  |
| Reduced risk               | $\Delta R$ | 5975                    |
| Present value of cost      | Pc         | 500000                  |
| Present value of benefit   | Pb         | 62018.872               |
| <b>Cost-benefit ratio</b>  | <b>C/B</b> | <b>8.06206215 &gt;1</b> |

**NOT Cost Beneficial**

### REDUCE CHANCE OF NAV. ERR BY MAKING SENSORS UNACCESSIBLE

#### Sensor accessible

|                               |    |                |
|-------------------------------|----|----------------|
| Probability of accident       | P0 | 0.0007297      |
| Consequence, Cost of accident | C0 | 76235444 kr    |
| Cost of risk                  | R0 | 55629 Per year |

#### Sensor inaccessible

|                               |    |             |
|-------------------------------|----|-------------|
| Reduction in probability      |    | 8 %         |
| New probability               | P1 | 0.00067373  |
| Consequence, Cost of accident | C1 | 76235444 kr |
| Risk                          | R1 | 51362       |

|                            |            |                         |
|----------------------------|------------|-------------------------|
| Increase in operation cost | Opex       | 0                       |
| Investment                 | Capex      | 2000                    |
| Reduced risk               | $\Delta R$ | 4267                    |
| Present value of cost      | Pc         | 2000                    |
| Present value of benefit   | Pb         | 44285.6861              |
| <b>Cost-benefit ratio</b>  | <b>C/B</b> | <b>0.04516132 &lt;1</b> |

**Cost Beneficial**

## STRENGTHENING OF HULL TO AVOID TAKING IN WATER

### Normal

|                               |    |                 |
|-------------------------------|----|-----------------|
| Probability of accident       | P0 | 0.0049792       |
| Consequence, Cost of accident | C0 | 76235444 kr     |
| Cost of risk                  | R0 | 379592 Per year |

### Strengthened

|                               |    |             |
|-------------------------------|----|-------------|
| Reduction in probability      |    | 55 %        |
| New probability               | P1 | 0.0022364   |
| Consequence, Cost of accident | C1 | 76235444 kr |
| Risk                          | R1 | 170493      |

|                            |            |                         |
|----------------------------|------------|-------------------------|
| Increase in operation cost | Opex       | 0                       |
| Investment                 | Capex      | 500000                  |
| Reduced risk               | $\Delta R$ | 209099                  |
| Present value of cost      | Pc         | 500000                  |
| Present value of benefit   | Pb         | 2170371.7               |
| <b>Cost-benefit ratio</b>  | <b>C/B</b> | <b>0.23037528 &lt;1</b> |

*Cost Beneficial*

## Cost Benefit Analysis

|                      |   |           |
|----------------------|---|-----------|
| Interest rate        | i | 5 %       |
| Expected lifetime    | n | 15        |
| Present value factor |   | 10.379658 |

### IMPROVED DAMAGE STABILITY TO AVOID SINKING/CAPSIZING

#### Normal

|                               |    |                |
|-------------------------------|----|----------------|
| Probability of accident       | P0 | 0.0525         |
| Consequence, Cost of accident | C0 | 1500000 kr     |
| Cost of risk                  | R0 | 78750 Per year |

#### Improved

|                               |    |            |
|-------------------------------|----|------------|
| Reduction in probability      |    | 80 %       |
| New probability               | P1 | 0.0105     |
| Consequence, Cost of accident | C1 | 1500000 kr |
| Risk                          | R1 | 15750      |

|                            |            |                         |
|----------------------------|------------|-------------------------|
| Increase in operation cost | Opex       | 0                       |
| Investment                 | Capex      | 500000                  |
| Reduced risk               | $\Delta R$ | 63000                   |
| Present value of cost      | Pc         | 500000                  |
| Present value of benefit   | Pb         | 653918.456              |
| <b>Cost-benefit ratio</b>  | <b>C/B</b> | <b>0.76462133 &lt;1</b> |

*Cost Beneficial*

### STRENGTHENING OF HULL TO AVOID TAKING IN WATER

#### Normal

|                               |    |                  |
|-------------------------------|----|------------------|
| Probability of accident       | P0 | 0.01386          |
| Consequence, Cost of accident | C0 | 76235444 kr      |
| Cost of risk                  | R0 | 1056623 Per year |

#### Strengthened

|                               |    |             |
|-------------------------------|----|-------------|
| Reduction in probability      |    | 51 %        |
| New probability               | P1 | 0.006732    |
| Consequence, Cost of accident | C1 | 76235444 kr |
| Risk                          | R1 | 513217      |

|                            |            |                         |
|----------------------------|------------|-------------------------|
| Increase in operation cost | Opex       | 0                       |
| Investment                 | Capex      | 500000                  |
| Reduced risk               | $\Delta R$ | 543406                  |
| Present value of cost      | Pc         | 500000                  |
| Present value of benefit   | Pb         | 5640370.98              |
| <b>Cost-benefit ratio</b>  | <b>C/B</b> | <b>0.08864665 &lt;1</b> |

*Cost Beneficial*

## DESIGN OF EMERGENCY BUTTON

### Bad design

|                               |    |                |
|-------------------------------|----|----------------|
| Frequency of accident         | F0 | 0.00033762     |
| Consequence, Cost of accident | C0 | 76235444 kr    |
| Cost of risk                  | R0 | 25738 Per year |

### Good design

|                               |    |             |
|-------------------------------|----|-------------|
| Reduction in frequency        |    | 10 %        |
| New frequency                 | F1 | 0.00030281  |
| Consequence, Cost of accident | C1 | 76235444 kr |
| Risk                          | R1 | 23085       |

|                            |            |                         |
|----------------------------|------------|-------------------------|
| Increase in operation cost | Opex       | 0                       |
| Investment                 | Capex      | 1000                    |
| Reduced risk               | $\Delta R$ | 2653                    |
| Present value of cost      | Pc         | 1000                    |
| Present value of benefit   | Pb         | 27539.1113              |
| <b>Cost-benefit ratio</b>  | <b>C/B</b> | <b>0.03631199 &lt;1</b> |

*Cost Benefitial*

# Cost Benefit Analysis

|                      |   |           |
|----------------------|---|-----------|
| Interest rate        | i | 5 %       |
| Expected lifetime    | n | 15        |
| Present value factor |   | 10.379658 |

## ALARM THAT ALERTS THE FIRE DEPARTMENT

### No alarm to fire department

|                               |    |                  |
|-------------------------------|----|------------------|
| Probability of accident       | P0 | 0.0158           |
| Consequence, Cost of accident | C0 | 76235444 kr      |
| Cost of risk                  | R0 | 1204520 Per year |

### Alarm to firedepartment

|                               |    |             |
|-------------------------------|----|-------------|
| Reduction in probability      |    | 36 %        |
| New probability               | P1 | 0.0101      |
| Consequence, Cost of accident | C1 | 76235444 kr |
| Risk                          | R1 | 769978      |

|                            |            |                        |
|----------------------------|------------|------------------------|
| Increase in operation cost | Opex       | 60000                  |
| Investment                 | Capex      | 0                      |
| Reduced risk               | $\Delta R$ | 434542                 |
| Present value of cost      | Pc         | 622779.482             |
| Present value of benefit   | Pb         | 4510397.67             |
| <b>Cost-benefit ratio</b>  | <b>C/B</b> | <b>0.1380764 &lt;1</b> |

*Cost Benefitial*

## EXTRA FIRE EXTINGUISHER

### 1 Extinguisher

|                               |    |                  |
|-------------------------------|----|------------------|
| Probability of accident       | P0 | 0.0158           |
| Consequence, Cost of accident | C0 | 76235444 kr      |
| Cost of risk                  | R0 | 1204520 Per year |

### 2 Extinguisher

|                               |    |             |
|-------------------------------|----|-------------|
| Reduction in probability      |    | 23 %        |
| New probability               | P1 | 0.0122      |
| Consequence, Cost of accident | C1 | 76235444 kr |
| Risk                          | R1 | 930072      |

|                            |            |                         |
|----------------------------|------------|-------------------------|
| Increase in operation cost | Opex       | 0                       |
| Investment                 | Capex      | 350                     |
| Reduced risk               | $\Delta R$ | 274448                  |
| Present value of cost      | Pc         | 350                     |
| Present value of benefit   | Pb         | 2848672.21              |
| <b>Cost-benefit ratio</b>  | <b>C/B</b> | <b>0.00012286 &lt;1</b> |

*Cost Benefitial*



#### LIMITING FLAMMABLE MATERIAL ON FERRY

##### Normal

|                               |    |                 |
|-------------------------------|----|-----------------|
| Frequency of accident         | F0 | 0.00204278      |
| Consequence, Cost of accident | C0 | 76235444 kr     |
| Cost of risk                  | R0 | 155732 Per year |

##### Limited flammable material exposed

|                               |            |                         |
|-------------------------------|------------|-------------------------|
| Reduction in frequency        |            | 31 %                    |
| New frequency                 | F1         | 0.00141768              |
| Consequence, Cost of accident | C1         | 76235444 kr             |
| Risk                          | R1         | 108078                  |
| Increase in operation cost    | Opex       | 0                       |
| Investment                    | Capex      | 10000                   |
| Reduced risk                  | $\Delta R$ | 47655                   |
| Present value of cost         | Pc         | 10000                   |
| Present value of benefit      | Pb         | 494640.277              |
| <b>Cost-benefit ratio</b>     | <b>C/B</b> | <b>0.02021671 &lt;1</b> |

*Cost Benefitial*

#### REDUNDANCY IN CO2 SYSTEM

##### Normal

|                               |    |                 |
|-------------------------------|----|-----------------|
| Frequency of accident         | F0 | 0.00204278      |
| Consequence, Cost of accident | C0 | 76235444 kr     |
| Cost of risk                  | R0 | 155732 Per year |

##### Extra CO2

|                               |            |                         |
|-------------------------------|------------|-------------------------|
| Reduction in frequency        |            | 4 %                     |
| New frequency                 | F1         | 0.00196931              |
| Consequence, Cost of accident | C1         | 76235444 kr             |
| Risk                          | R1         | 150131                  |
| Increase in operation cost    | Opex       | 0                       |
| Investment                    | Capex      | 8000                    |
| Reduced risk                  | $\Delta R$ | 5601                    |
| Present value of cost         | Pc         | 8000                    |
| Present value of benefit      | Pb         | 58136.652               |
| <b>Cost-benefit ratio</b>     | <b>C/B</b> | <b>0.13760682 &lt;1</b> |

*Cost Benefitial*

## Cost Benefit Analysis

|                      |   |           |
|----------------------|---|-----------|
| Interest rate        | i | 5 %       |
| Expected lifetime    | n | 15        |
| Present value factor |   | 10.379658 |

### REGULAR CHECK, AND RESTOCK OF LIFEJACKETS

#### No check

|                               |    |               |
|-------------------------------|----|---------------|
| Probability of accident       | P0 | 0.00008       |
| Consequence, Cost of accident | C0 | 76235444 kr   |
| Cost of risk                  | R0 | 6099 Per year |

#### Regular check

|                               |    |             |
|-------------------------------|----|-------------|
| Reduction in probability      |    | 75 %        |
| New probability               | P1 | 0.00002     |
| Consequence, Cost of accident | C1 | 76235444 kr |
| Risk                          | R1 | 1525        |

|                            |            |                         |
|----------------------------|------------|-------------------------|
| Increase in operation cost | Opex       | 6000                    |
| Investment                 | Capex      | 0                       |
| Reduced risk               | $\Delta R$ | 4574                    |
| Present value of cost      | Pc         | 62277.9482              |
| Present value of benefit   | Pb         | 47477.8702              |
| <b>Cost-benefit ratio</b>  | <b>C/B</b> | <b>1.31172582 &gt;1</b> |

**NOT Cost Benefitial**

### FINE FOR STEALING LIFE JACKETS

#### No fine

|                               |    |               |
|-------------------------------|----|---------------|
| Frequency of accident         | F0 | 9.3144E-05    |
| Consequence, Cost of accident | C0 | 76235444 kr   |
| Cost of risk                  | R0 | 7101 Per year |

#### Fine

|                               |    |             |
|-------------------------------|----|-------------|
| Reduction in frequency        |    | 42 %        |
| New frequency                 | F1 | 5.4456E-05  |
| Consequence, Cost of accident | C1 | 76235444 kr |
| Risk                          | R1 | 4151        |

|                            |            |                         |
|----------------------------|------------|-------------------------|
| Increase in operation cost | Opex       | 0                       |
| Investment                 | Capex      | 1500                    |
| Reduced risk               | $\Delta R$ | 2949                    |
| Present value of cost      | Pc         | 1500                    |
| Present value of benefit   | Pb         | 30613.7307              |
| <b>Cost-benefit ratio</b>  | <b>C/B</b> | <b>0.04899762 &lt;1</b> |

**Cost Benefitial**

## Cost Benefit Analysis

|                      |   |           |
|----------------------|---|-----------|
| Interest rate        | i | 5 %       |
| Expected lifetime    | n | 15        |
| Present value factor |   | 10.379658 |

### MAKE IT HARD TO GET BY REGISTRATION SYSTEM WITHOUT BEING REGISTERED

#### No alarm to fire department

|                               |    |               |
|-------------------------------|----|---------------|
| Frequency of accident         | F0 | 0.00055886    |
| Consequence, Cost of accident | C0 | 3000000 kr    |
| Cost of risk                  | R0 | 1677 Per year |

#### Alarm to fire department

|                               |    |            |
|-------------------------------|----|------------|
| Reduction in frequency        |    | 17 %       |
| New frequency                 | F1 | 0.00046139 |
| Consequence, Cost of accident | C1 | 3000000 kr |
| Risk                          | R1 | 1384       |

|                            |            |                        |
|----------------------------|------------|------------------------|
| Increase in operation cost | Opex       | 0                      |
| Investment                 | Capex      | 5000                   |
| Reduced risk               | $\Delta R$ | 292                    |
| Present value of cost      | Pc         | 5000                   |
| Present value of benefit   | Pb         | 3035.11581             |
| <b>Cost-benefit ratio</b>  | <b>C/B</b> | <b>1.6473836 &gt;1</b> |

**NOT Cost Benefitial**

## C Appendix: Concept Development

### C.1 Concepts to Transport Passengers over the Channel

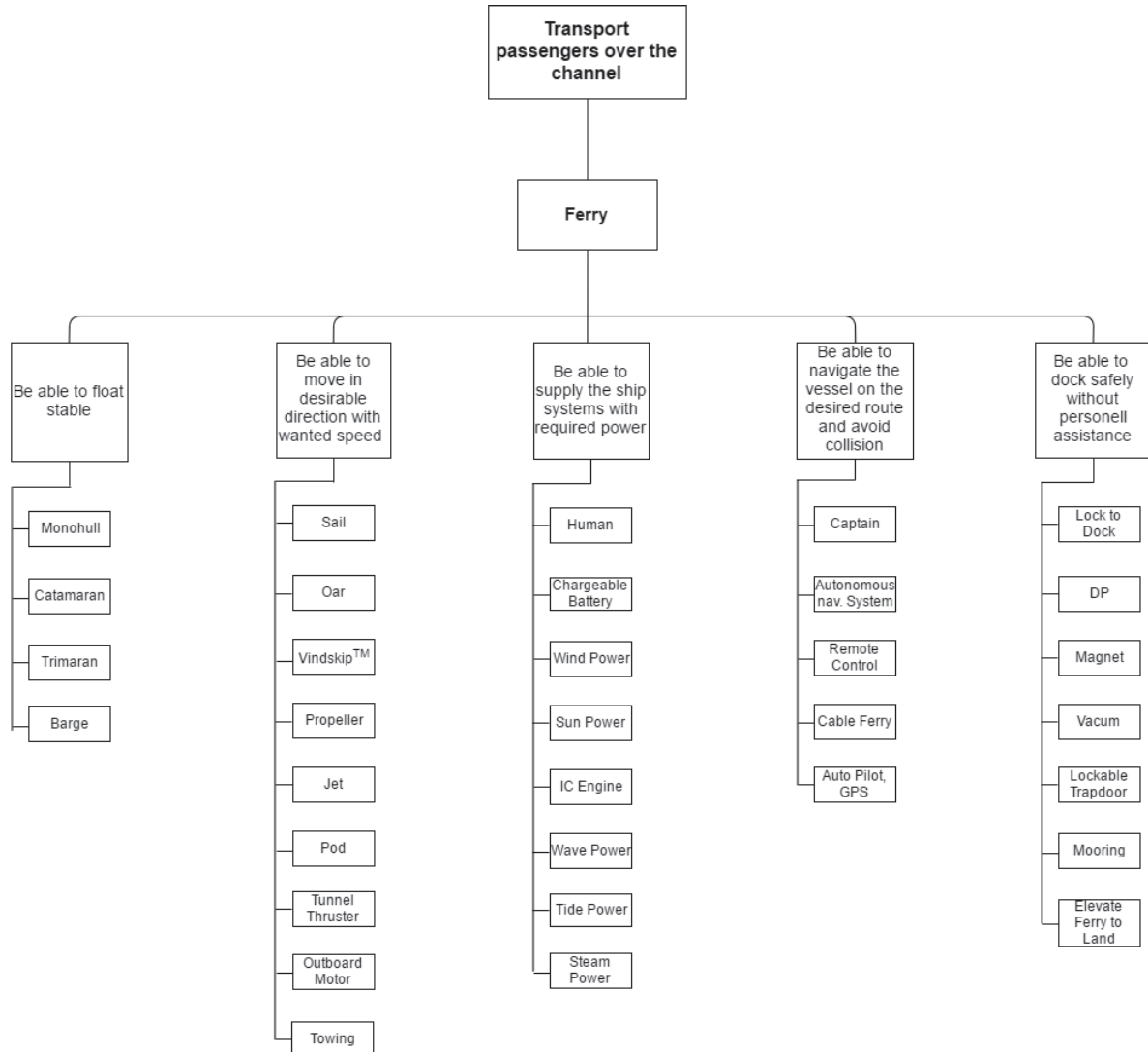

## C.2 Eliminated solutions

| Sub function | Solution option eliminated | Reason for elimination  |
|--------------|----------------------------|---|
| Propulsion   | Sail                       | Low availability and Requirement of no personnel violated   |
| Propulsion   | Oars                       | Requirement of no personnel violated or large requirement for adaptations without large efficiency gain                       |
| Propulsion   | Windship                   | Solution never tested before, unsuitable for unmanned vessel  |
| Power supply | Human                      | Requires human to use bicycle or similar. As we cannot demand this from passenger the requirement of no personnel is violated |
| Power supply | Wind power                 | Little wind in the area, unstable power supply, high cost   |
| Power supply | Wave power                 | Little waves in the area, unstable power supply, high cost  |
| Power supply | Tidal power                | Field is still under developments, no commercial products available, high cost  |
| Power supply | Steam power                | Low efficiency, outdated, low safety and reliability  |
| Navigation   | Captain                    | Requirement of no personnel violated  |
| Navigation   | Remote control             | Requirement of no personnel violated, even if on land   |
| Navigation   | Cable ferry                | Cable across the channel is not possible, obstacle for traffic  |
| Navigation   | Auto pilot, GPS            | Needs someone to attend/watch over – Requirement of no personnel violated   |
| Docking      | Elevate ferry to dock      | Excluded in preliminary project thesis. Considered unreliable with potentially large safety hazards                           |
| Docking      | Mooring by rope            | Requirement of no personnel violated  |

Table 1: Round one of eliminations during concept development

| <b>Sub function</b> | <b>Solution option</b>        | <b>Reason for elimination</b>  |
|---------------------|-------------------------------|--|
| Hull                | Barge                         | Unsatisfactory hydrodynamic abilities and low aesthetic quality  |
| Propulsion          | Outboard motor                | Lower safety level and ferry unable to dock with front/back  |
| Propulsion          | Tunnel thruster (+ propeller) | Demands the ferry to turn 180 degrees each transit. As the transit route is 100 m this will be too unpractical.  |
| Power supply        | Sun power                     | Not enough sun in Trondheim and demands large area   |
| Docking             | Dynamic positioning           | Infeasible that the ferry must use power constantly to maintain position in dock. Important for passengers perceived safety that the ferry is physically attached to dock. |

Table 2: Round two of eliminations during concept development

| <b>Sub function</b> | <b>Solution option</b> | <b>Reason for elimination</b>   |
|---------------------|------------------------|---|
| Hull                | Trimaran               | Benefits not as relevant at low speeds, catamaran is better           |
| Propulsion          | Jet                    | Benefits not as relevant at low speeds, suitable for large ferries    |
| Propulsion          | Conventional propeller | Poor navigational abilities, need to be adjustable                    |
| Power supply        | IC Engine              | Fire risk, need to refuel often, Requirement of no personnel violated |

Table 3: Round three of eliminations during concept development

### C.3 Hull Shape Sketches

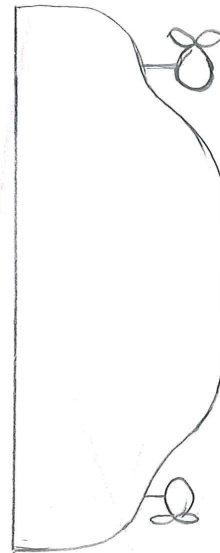
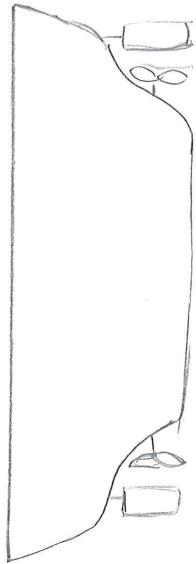
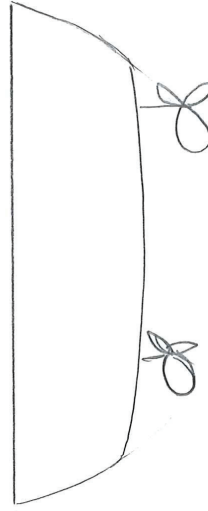
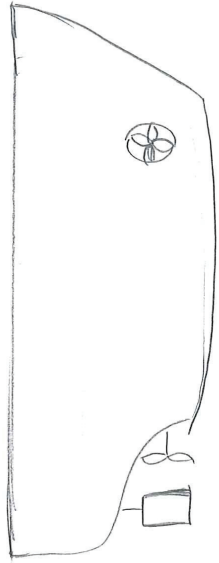

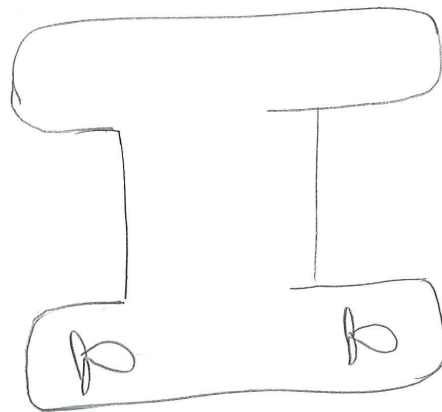
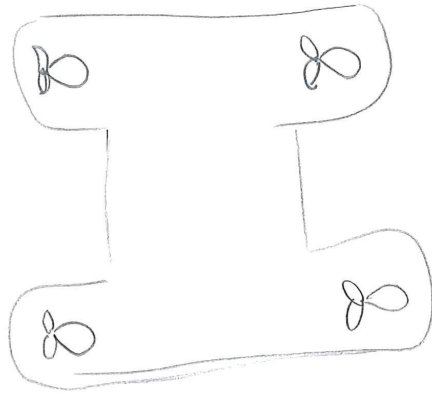
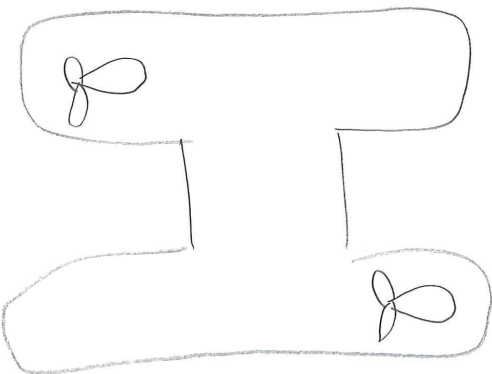
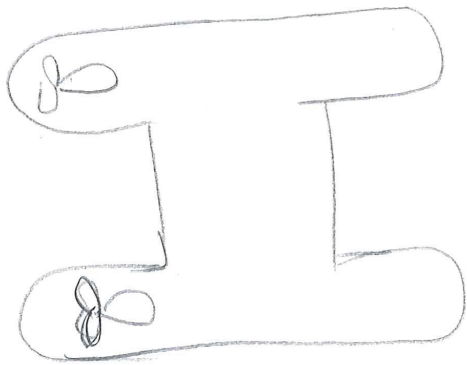



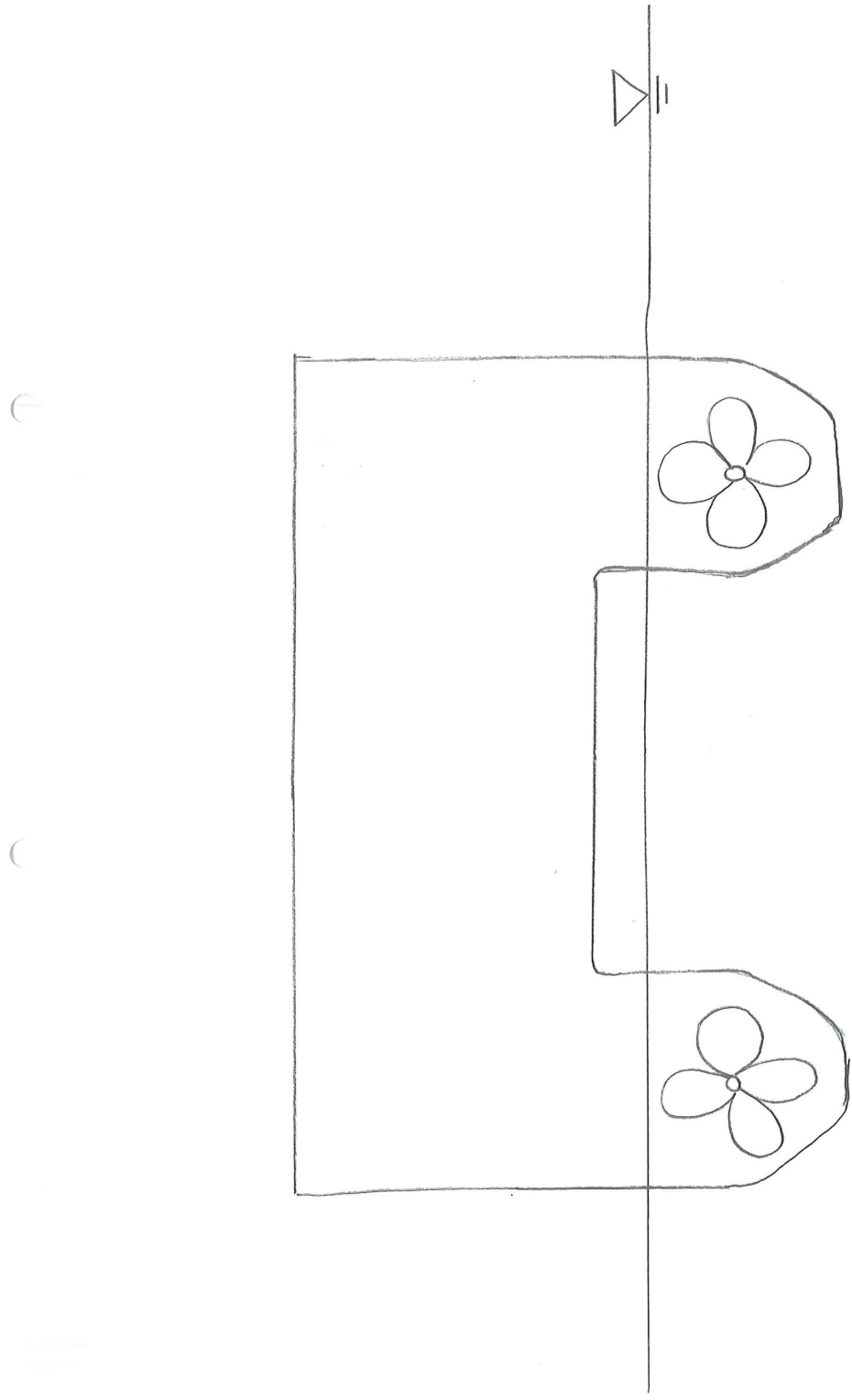

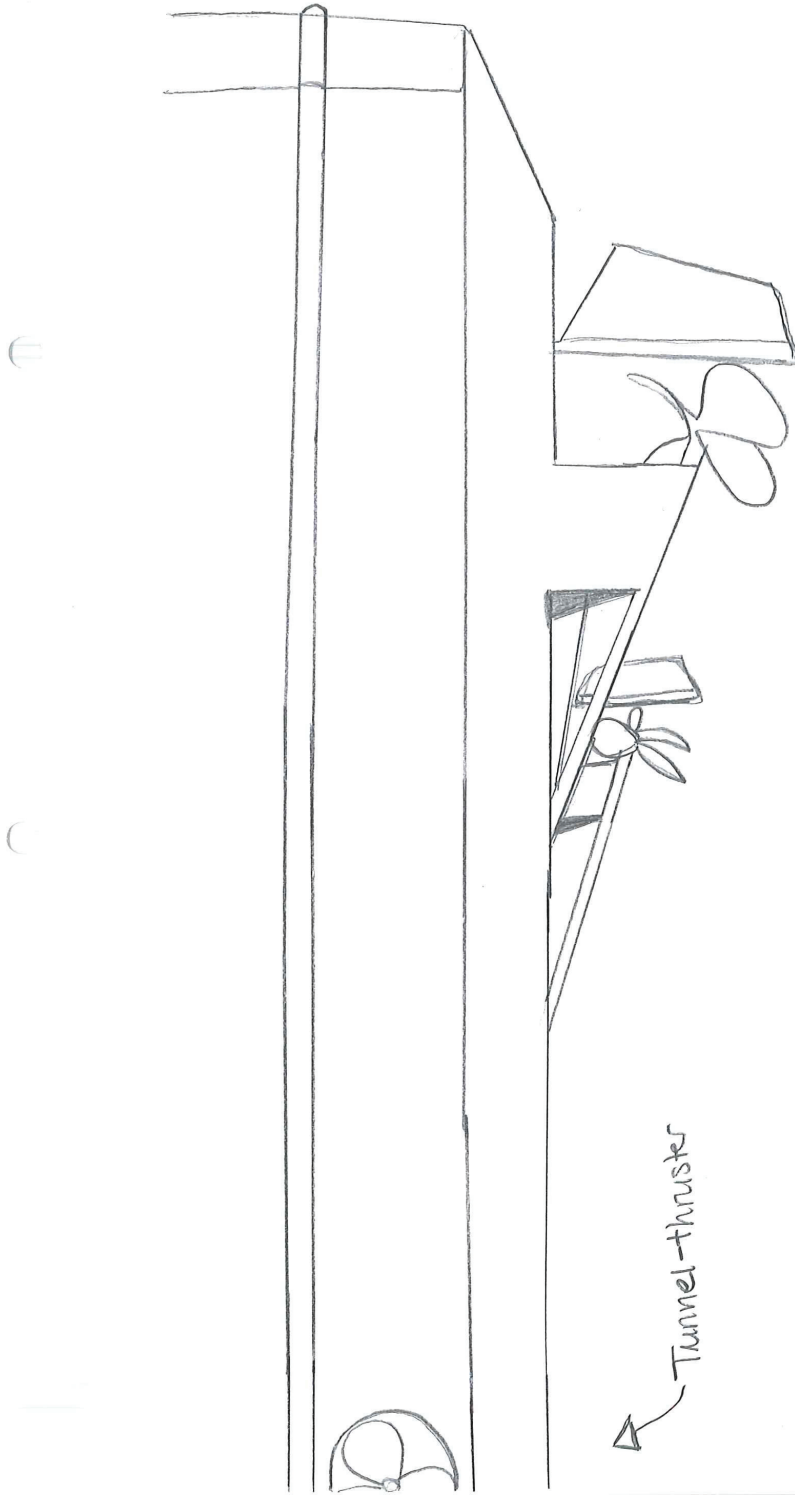

↖ Tunnel-thruster

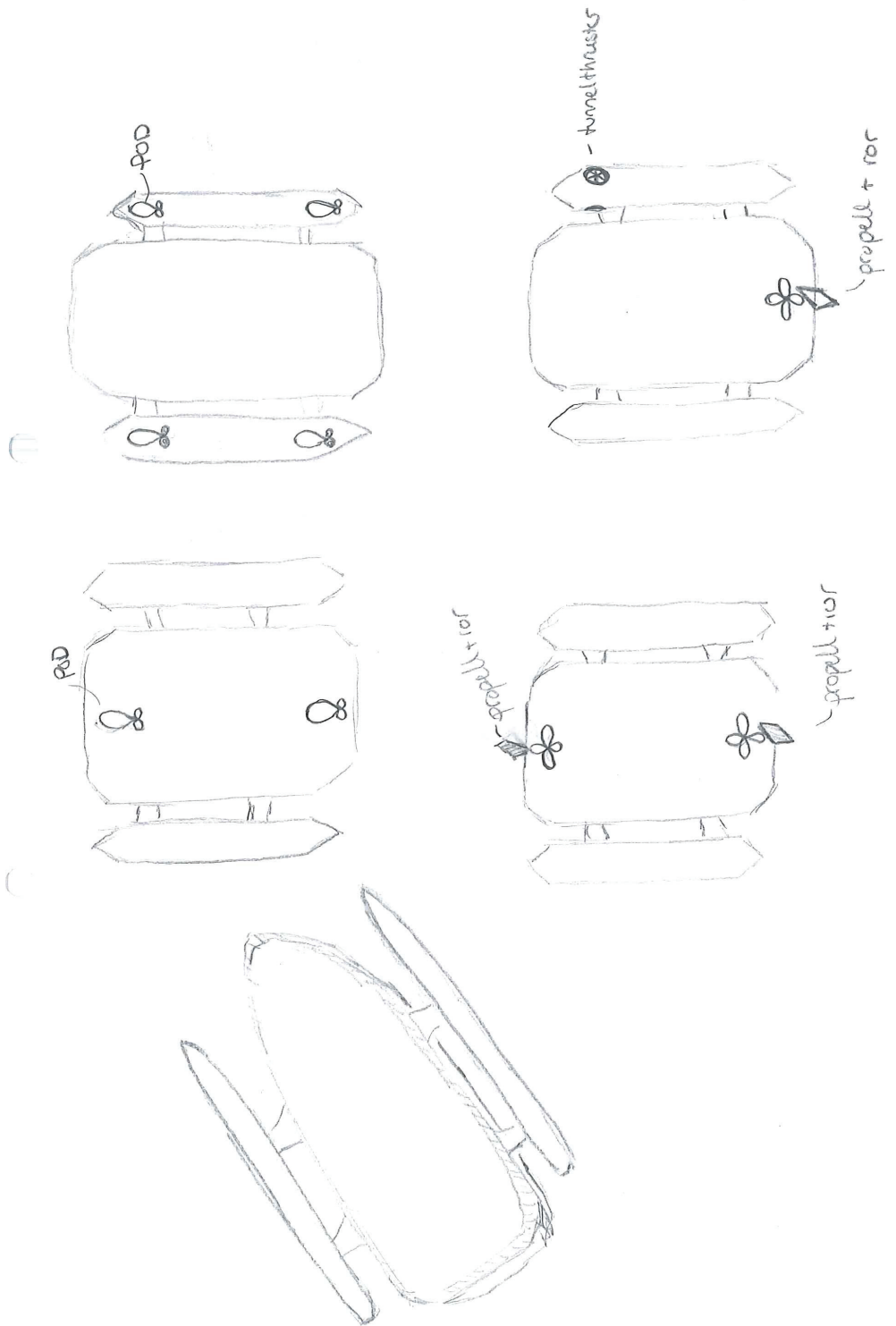

Battery room  
 2x thruster  
 CO2 storage  
 Hydraulic cog

CO2 storage  
 for accu (battery)  
 from battery

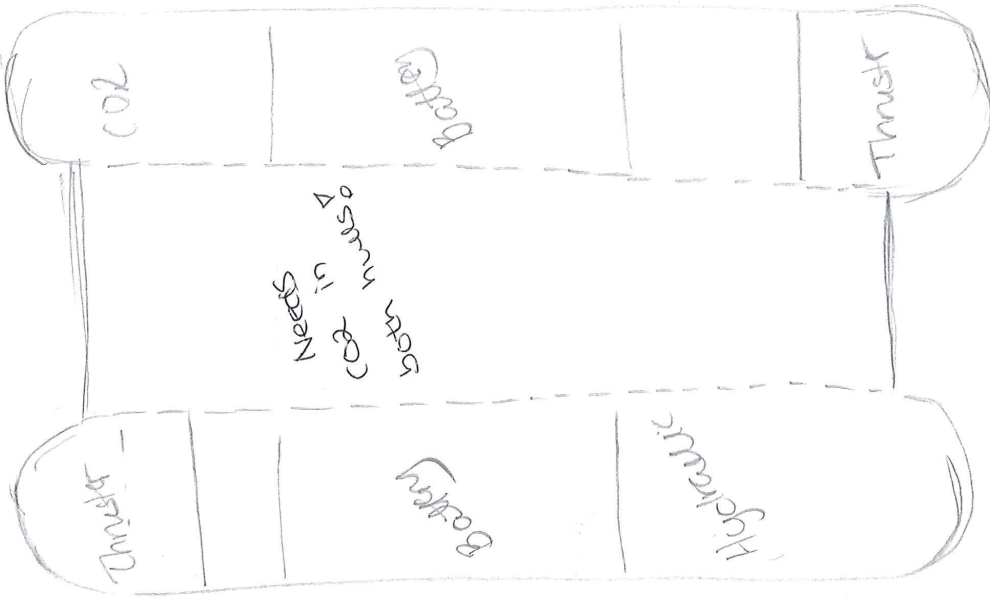

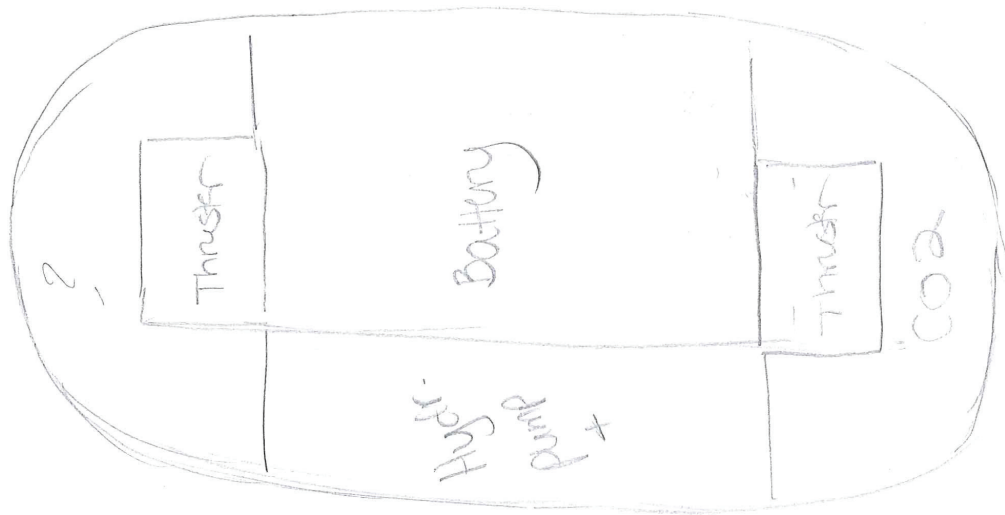

## C.4 Sketches of Mooring Alternatives

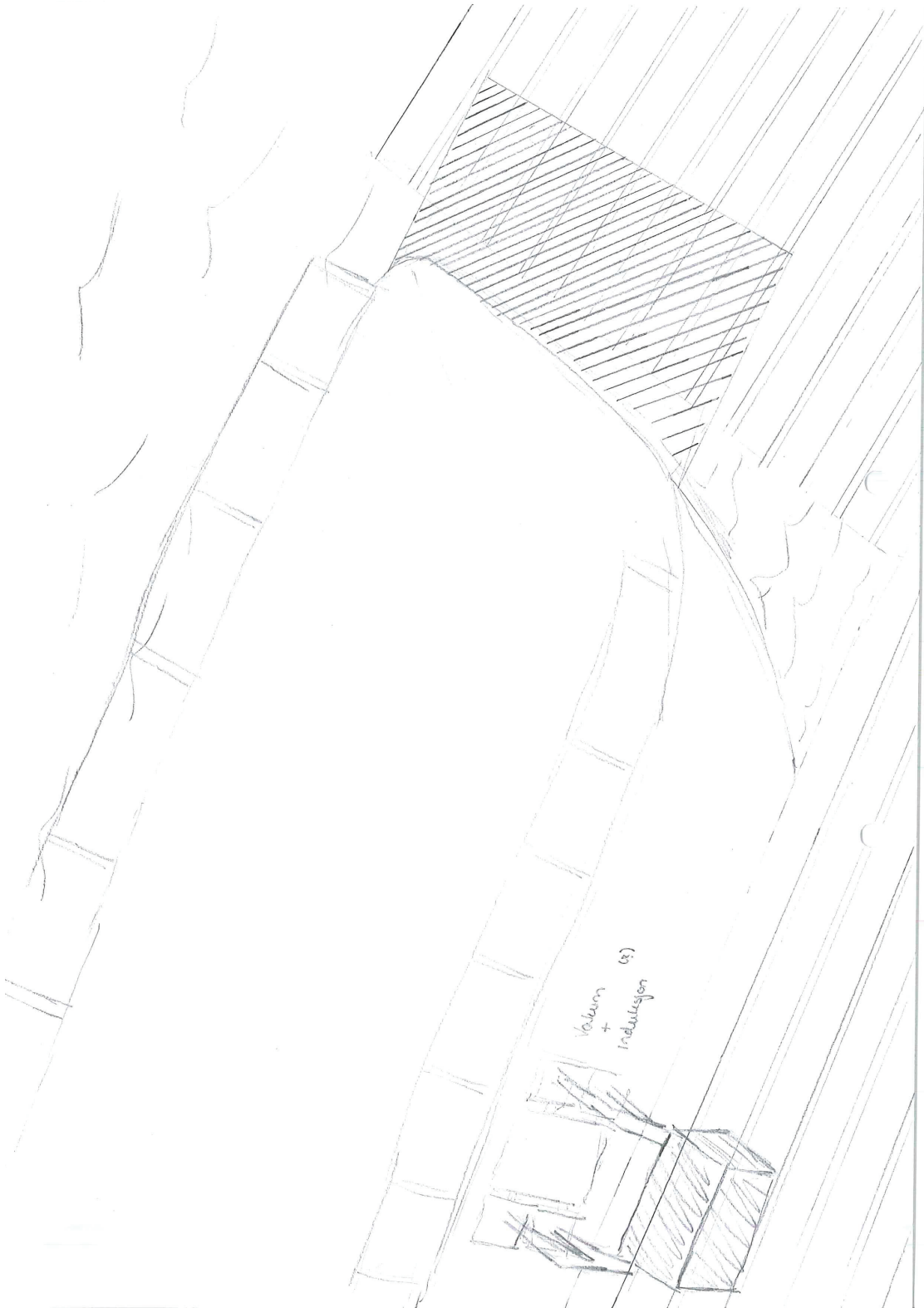

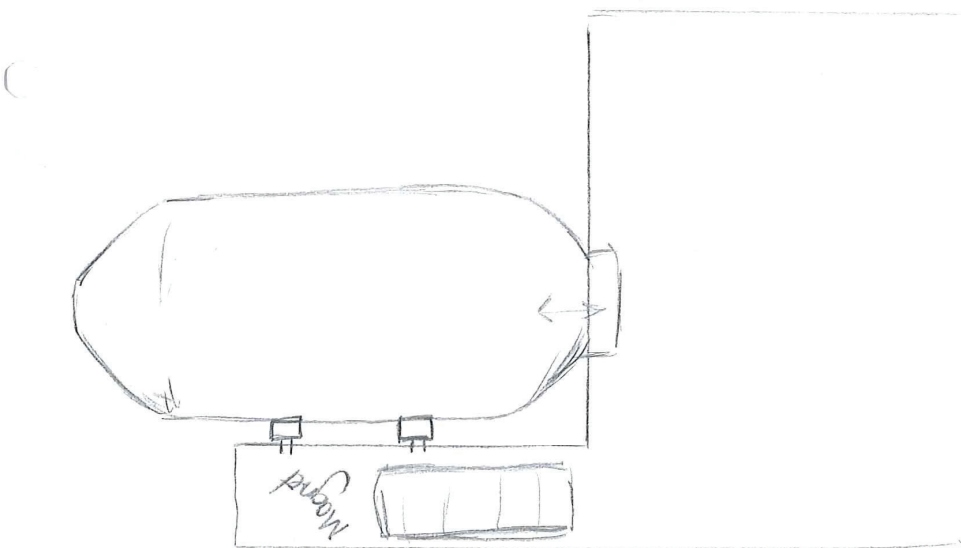
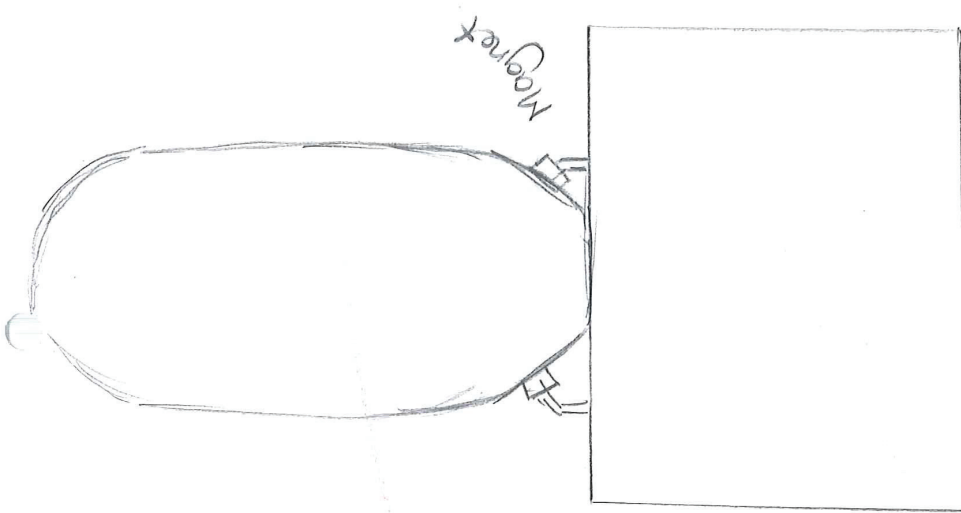

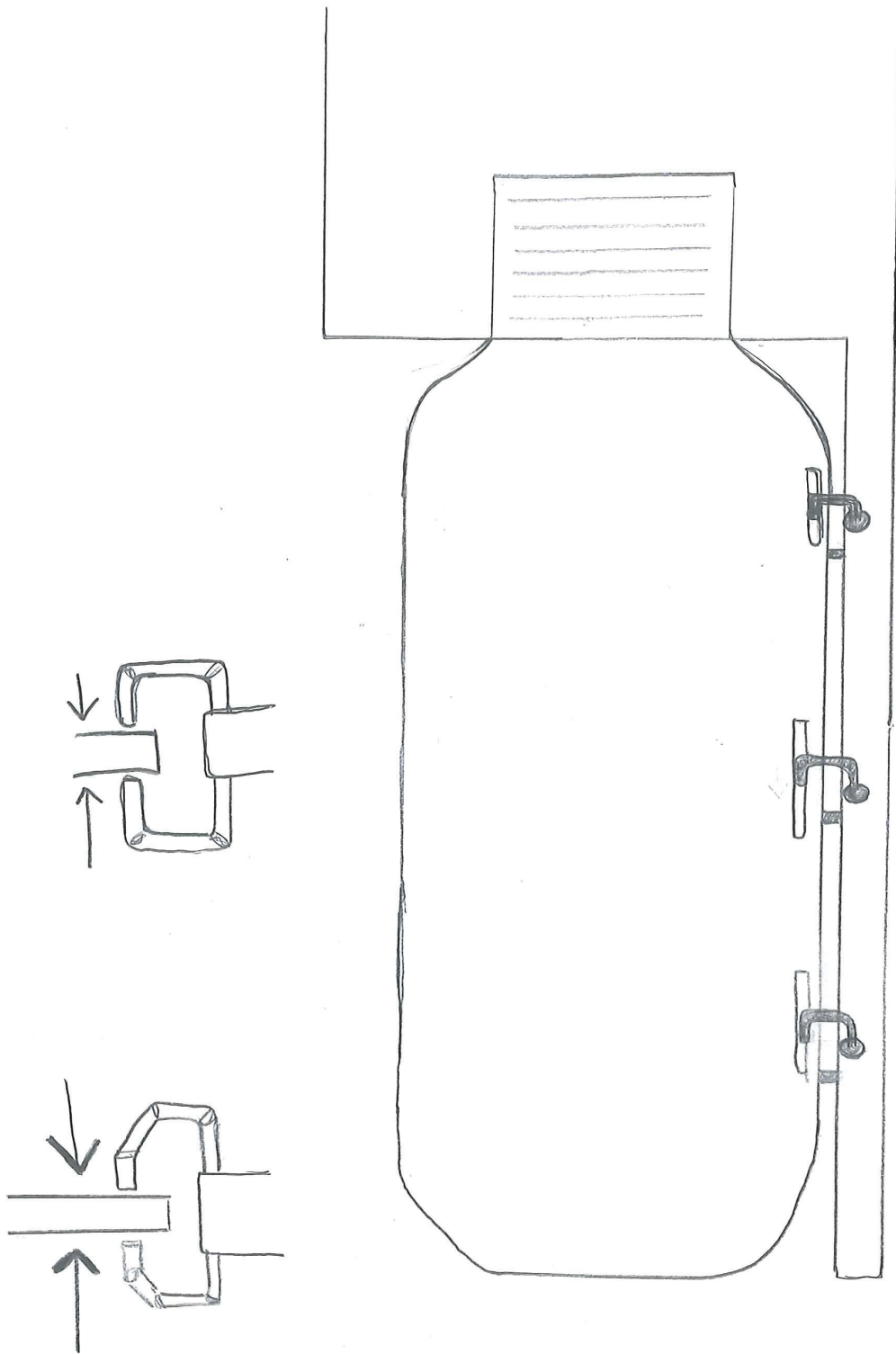





### C.5 Sketch of Gangway Solution

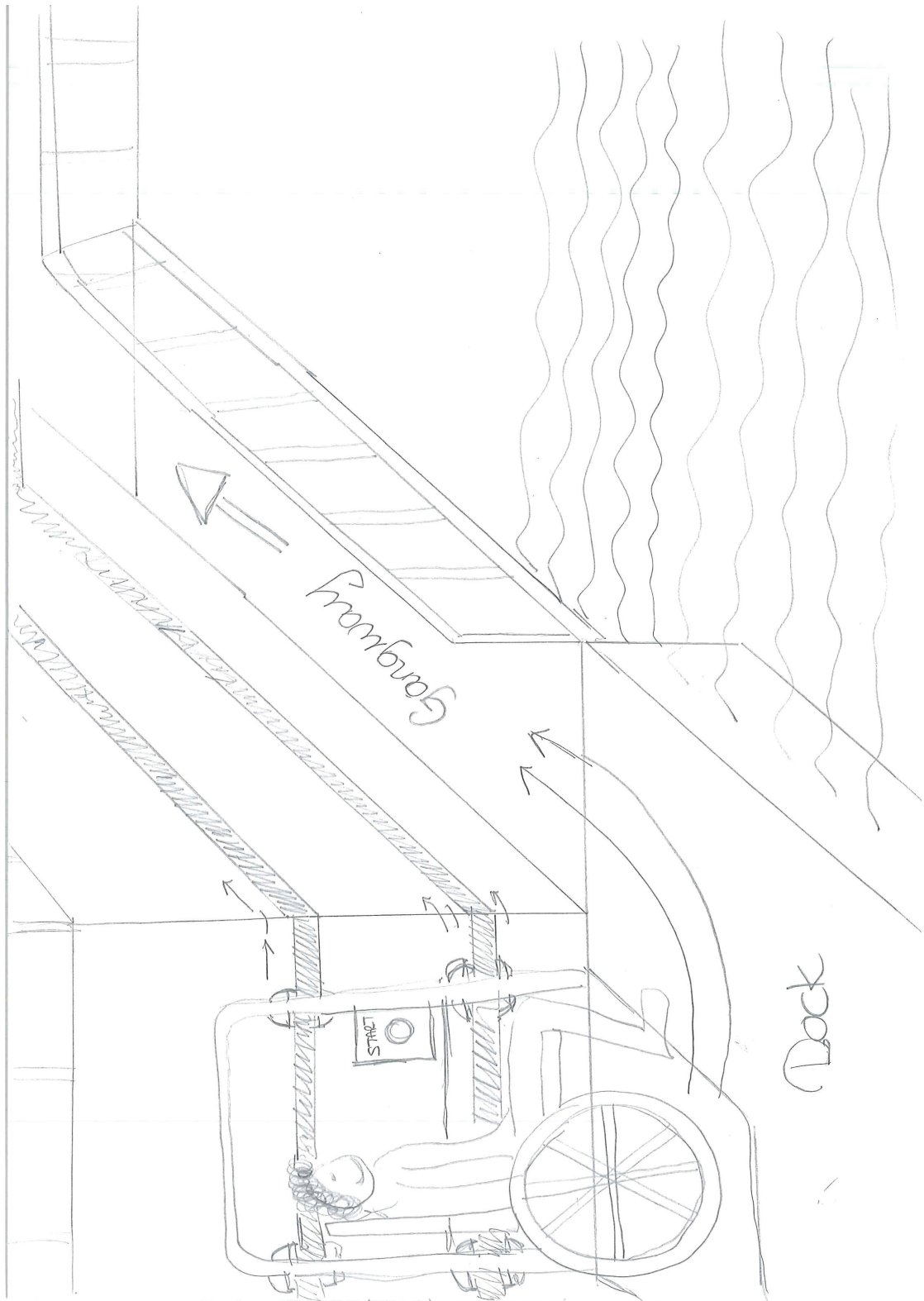

## C.6 Dock Area at Ravnkloa and Fosenkaia

### Dock Placement at Ravnkloa



### Dock Placement at Fosenkaia



## C.7 SBSD Version 1 and 2

### SBSD Version 1

| SHIP IDENTIFICATION |                            |
|---------------------|----------------------------|
| Project:            | Autonomous Passenger Ferry |
| Project manager:    | Egil Eide, NTNU 2017       |
| Name:               | EL-len AuTomine            |

| MISSION DESCRIPTION |                                   |
|---------------------|-----------------------------------|
| Operation area:     | Ravnkloa - Fosenskaia             |
| Description:        | Regular, year round ferry service |
| Target Market       | Passenger Transport               |

| PAYLOAD CAPACITY AND PERFORMANCE |     |        |
|----------------------------------|-----|--------|
| Passenger Capacity:              | 12  | People |
| Endurance:                       | 5   | Min    |
| Range roundtrip:                 | 200 | m      |
| Trial Speed:                     | 4   | knots  |

| MACHINERY AND ROUGH POWER DEMAND |                |
|----------------------------------|----------------|
| Energy supply:                   | Li-ion Battery |
| Auxillary power:                 | Li-ion Battery |

| RULES AND REGULATIONS |           |         |
|-----------------------|-----------|---------|
| Class:                | Non       |         |
| Flag:                 | Norwegian |         |
| Crew:                 | 0         | persons |
| Landbased crew:       | 1         | person  |

| RESTRICTIONS TO THE MAIN DIMENSIONS |     |
|-------------------------------------|-----|
| On Routes:                          | Yes |
| In Ports:                           | No  |

| PASSENGER CAPACITY I    |             |                   |                 |             |                   |
|-------------------------|-------------|-------------------|-----------------|-------------|-------------------|
| Passenger Category      | No of units | Unit Weight<br>kg | Unit Area<br>m2 | Height<br>m | Unit Volume<br>m3 |
| Person                  | 12          | 75                | 0.3             | 2.4         | 0.72              |
| Wheelchair              | 0           | 225               | 1.1             | 2.4         | 2.64              |
| Bicycle                 | 12          | 18                | 1.26            | 2.4         | 3.02              |
| Stroller                | 0           | 25                | 0.75            | 2.4         | 1.80              |
| Dog                     | 0           | 15                | 0.35            | 2.4         | 0.84              |
| <b>Total passengers</b> | <b>12</b>   | <b>1116</b>       | <b>18.72</b>    |             | <b>44.93</b>      |

| PASSENGER CAPACITY II   |             |                   |                 |             |                   |
|-------------------------|-------------|-------------------|-----------------|-------------|-------------------|
| Passenger Category      | No of units | Unit Weight<br>kg | Unit Area<br>m2 | Height<br>m | Unit Volume<br>m3 |
| Person                  | 9           | 75                | 0.3             | 2.4         | 0.72              |
| Wheelchair              | 3           | 225               | 1.1             | 2.4         | 2.64              |
| Bicycle                 |             | 18                | 1.26            | 2.4         | 3.02              |
| Stroller                |             | 25                | 0.75            | 2.4         | 1.80              |
| Dog                     |             | 15                | 0.35            | 2.4         | 0.84              |
| <b>Total passengers</b> | <b>12</b>   | <b>1350</b>       | <b>6</b>        |             | <b>14.40</b>      |

| PASSENGER CAPACITY III  |             |                   |                 |             |                   |
|-------------------------|-------------|-------------------|-----------------|-------------|-------------------|
| Passenger Category      | No of units | Unit Weight<br>kg | Unit Area<br>m2 | Height<br>m | Unit Volume<br>m3 |
| Person                  | 10          | 75                | 0.3             | 2.4         | 0.72              |
| Wheelchair              | 1           | 225               | 1.1             | 2.4         | 2.64              |
| Bicycle                 | 2           | 18                | 1.26            | 2.4         | 3.02              |
| Stroller                | 1           | 25                | 0.75            | 2.4         | 1.80              |
| Dog                     | 1           | 15                | 0.35            | 2.4         | 0.84              |
| <b>Total passengers</b> | <b>12</b>   | <b>1051</b>       | <b>7.72</b>     |             | <b>18.528</b>     |

| PASSENGER CAPACITY IV   |             |                   |                 |             |                   |
|-------------------------|-------------|-------------------|-----------------|-------------|-------------------|
| Passenger Category      | No of units | Unit Weight<br>kg | Unit Area<br>m2 | Height<br>m | Unit Volume<br>m3 |
| Person                  | 10          | 75                | 0.3             | 2.4         | 0.72              |
| Wheelchair              | 1           | 225               | 1.1             | 2.4         | 2.64              |
| Bicycle                 | 5           | 18                | 1.26            | 2.4         | 3.02              |
| Stroller                | 1           | 25                | 0.75            | 2.4         | 1.80              |
| Dog                     |             | 15                | 0.35            | 2.4         | 0.84              |
| <b>Total passengers</b> | <b>12</b>   | <b>1090</b>       | <b>11.15</b>    |             | <b>26.76</b>      |

| PASSENGER CAPACITY VI   |             |                   |                 |             |                   |
|-------------------------|-------------|-------------------|-----------------|-------------|-------------------|
| Passenger Category      | No of units | Unit Weight<br>kg | Unit Area<br>m2 | Height<br>m | Unit Volume<br>m3 |
| Person                  | 12          | 75                | 0.3             | 2.4         | 0.72              |
| Wheelchair              | 0           | 225               | 1.1             | 2.4         | 2.64              |
| Bicycle                 | 0           | 18                | 1.26            | 2.4         | 3.02              |
| Stroller                | 0           | 25                | 0.75            | 2.4         | 1.80              |
| Dog                     | 0           | 15                | 0.35            | 2.4         | 0.84              |
| <b>Total passengers</b> | 12          | 900               | 3.6             |             | 8.64              |

| PASSENGER SPACES           |       |         |            |             |            |              |
|----------------------------|-------|---------|------------|-------------|------------|--------------|
| Name/Use of space          | Seats | m2/seat | m2/pax     | Height<br>m | Area<br>m2 | Volume<br>m3 |
| Lounge                     | 12    | 0.4     | 0.4        | 2.4         | 4.8        | 11.52        |
| Passenger Public Spaces    |       |         | 0.4 m2/pax |             | 4.8        | 11.52        |
| TOTAL PASSENGER FACILITIES |       |         | 0.4 m2/pax |             | 4.8        | 11.52        |

| SHIP EQUIPMENT                     |        |           |         |        |           |             |
|------------------------------------|--------|-----------|---------|--------|-----------|-------------|
| (Use pr pc)                        | Number | Unit Area | Covered | Height | Covered   | Covered     |
| Name/Use of deck:                  |        | m2        | %       | m      | Unit area | Unit Volume |
|                                    |        |           |         |        | m2        | m3          |
| Sensors                            | 2      | 0.008     | 0       | 0.07   | 0.00      | 0.00        |
| Cable storage                      | 2      | 0.150     | 100     | 2.40   | 0.15      | 0.36        |
| Computer                           | 1      | 1.200     | 100     | 0.25   | 1.20      | 0.30        |
| Surveillance                       | 2      | 0.035     | 100     | 0.08   | 0.04      | 0.00        |
| Air vent                           | 2      | 0.035     | 50      | 2.00   | 0.02      | 0.04        |
| Ramp for boarding                  | 2      | 0.075     | 0       | 1.00   | 0.00      | 0.00        |
| Hydraulic sylinder                 | 4      | 0.044     | 0       | 0.05   | 0.00      | 0.00        |
| Information screen                 | 2      | 0.028     | 100     | 0.33   | 0.03      | 0.00924     |
| <b>Total ship equipment spaces</b> |        | 2.04      |         |        | 1.66      | 1.12        |

| RESCUE AND FIREFIGHTING                      |        |           |         |        |           |             |
|--|--------|-----------|---------|--------|-----------|-------------|
| Name/Use of Deck:                            | Number | Unit Area | Covered | Height | Covered   | Covered     |
|  | Units  | m2        | %       | m      | unit area | unit Volume |
|  |        |           |         |        | m2        | m3          |
| Life jackets child                           | 12     | 0.18      | 100     | 0.10   | 0.18      | 0.02        |
| Life jackets adult                           | 12     | 0.23      | 100     | 0.12   | 0.23      | 0.03        |
| Fire detectors                               | 4      | 0.0001    | 100     | 0.05   | 0.00      | 0.00        |
| Fire extinguisher                            | 2      | 0.02      | 100     | 0.50   | 0.02      | 0.01        |
| Life buoy                                    | 2      | 0.44      | 100     | 0.13   | 0.44      | 0.06        |
| <b>Total rescue and fire fighting spaces</b> |        | 5.83      |         |        | 5.83      | 0.68        |

|                              |  |      |  |  |      |      |
|------------------------------|--|------|--|--|------|------|
| <b>TOTAL SHIP OUTFITTING</b> |  | 7.87 |  |  | 7.49 | 1.79 |
|------------------------------|--|------|--|--|------|------|



|                                    |                |           |           |
|------------------------------------|----------------|-----------|-----------|
| Machinery Type                     | Electric drive |           |           |
| No of pods                         | 2              |           |           |
| Season                             | Mid            | High      | Weekend   |
| Speed                              | 4 kn           | 4 kn      | 4 kn      |
| Input propulsion power (pr pod)    | 2.5 kW         | 2.5 kW    | 2.5 kW    |
| Installed propulsion power(pr pod) | 10.74 kWh      | 10.74 kWh | 10.74 kWh |
| Range before charging              | 4.2 h          | 4.2 h     | 4.2 h     |
| Extra power (other systems)        | 5.37 kWh       | 5.37 kWh  | 5.37 kWh  |
| Number of batteries in total       | 10 pc          | 10 pc     | 10 pc     |
| Total installed power              | 26.85 kWh      | 26.85 kWh | 26.85 kWh |

| ROOMS                        | Height | Area        | Volume      |
|------------------------------|--------|-------------|-------------|
| Name/ Use of Space:          | m      | m2          | m3          |
| Pump room, bilge (1 stk)     | 1.2    | 0.08        | 0.09        |
| Thruster room (2 stk)        | 1.2    | 1.00        | 1.20        |
| Fire fighting room (co2)     | 1.2    | 0.26        | 0.31        |
| Manual Bilge pump            | 1.2    | 0.09        | 0.11        |
| Hydraulic aggr. Room (2 stk) | 1.2    | 0.34        | 0.41        |
| Battery room                 | 1.2    | 3.60        | 4.32        |
| <b>Technical spaces</b>      |        | <b>5.37</b> | <b>6.44</b> |

| TANKS AND VOIDS              | Consump. | Consump. | Range | Endurance | Margin | Volume   |
|------------------------------|----------|----------|-------|-----------|--------|----------|
| Name/ Use of space:          | g/kWh    | ton/day  | nm    | days      | factor | m3       |
| VOIDS                        |          |          |       |           |        | 2        |
| <b>Tanks and Void Spaces</b> |          |          |       |           |        | <b>2</b> |

|   |                        |
|---|------------------------|
| Gross volume battery room               | 4.32 m <sup>3</sup>    |
| Amount CO <sub>2</sub>                  | 1.50 kg/m <sup>3</sup> |
| Density CO <sub>2</sub>                 | 450 kg/m <sup>3</sup>  |
| Total amount CO <sub>2</sub> (min 2 kg) | 6.48 kg                |
| Estimated amount on board               | 7 kg                   |
| Total volume CO <sub>2</sub> tank       | 0.016 m <sup>3</sup>   |

| <b>LIGHTWEIGHT</b>       |                           |                    |                            |                             |
|--------------------------|---------------------------|--------------------|----------------------------|-----------------------------|
| <b>Skrog + maskineri</b> | <b>Unit weight<br/>kg</b> | <b>No of units</b> | <b>Total weight<br/>kg</b> | <b>Total weight<br/>ton</b> |
| Ramp for boarding        | 30                        | 2                  | 60                         | 0.06                        |
| Fence                    | 30                        | 2                  | 60                         | 0.06                        |
| Anchor incl rope         | 30                        | 2                  | 60                         | 0.06                        |
| Superstructure           | 450                       | 1                  | 450                        | 0.45                        |
| Ship outfitting          | 184                       | 1                  | 184                        | 0.184                       |
| Battery                  | 24.3                      | 10                 | 243                        | 0.243                       |
| CO2 tank                 | 19                        | 2                  | 38                         | 0.038                       |
| Reserve Bilge pump, el   | 1.5                       | 2                  | 3                          | 0.003                       |
| Thruster system          | 33.5                      | 2                  | 67                         | 0.067                       |
| CO2 fire system          | 25                        | 1                  | 25                         | 0.025                       |
| Hull structure           | 400                       | 1                  | 400                        | 0.4                         |
| Hydr. Aggr. Inkl oil     | 26.4                      | 2                  | 52.8                       | 0.0528                      |
| Bilge pump               | 1.5                       | 4                  | 6                          | 0.006                       |
| Safety/ Rescue equipment | 41                        | 1                  | 41                         | 0.041                       |
| Main Deck                | 300                       | 1                  | 300                        | 0.3                         |
| <b>Total</b>             | GV                        |                    | 1989.7                     | 1.99                        |
| <b>Reserve</b>           | %                         | 1.0 %              |                            | 0.02                        |
| <b>LIGHTWEIGHT</b>       | GV                        |                    |                            | 2.01                        |

| SHIP OUTFITTING    | Unit weight | Unit | No of units | Total weight |
|--------------------|-------------|------|-------------|--------------|
| Sensors            | 30          | Kg   | 1           | 30           |
| Cable storage      | 10          | Kg   | 1           | 10           |
| Computer           | 25          | Kg   | 1           | 25           |
| Surveillance       | 0.5         | Kg   | 2           | 1            |
| Air vent           | 25          | Kg   | 2           | 50           |
| Hydraulic cylinder | 5           | Kg   | 4           | 20           |
| Information screen | 6           | Kg   | 2           | 12           |
| Seats              | 3           | Kg   | 12          | 36           |
| <b>Total</b>       |             | Kg   |             | <b>184</b>   |

| SAFETY/ RESCUE EQUIPMENT | Unit weight | Unit | No of units | Total weight |
|--------------------------|-------------|------|-------------|--------------|
| Life jackets child       | 0.44        | Kg   | 12          | 5.28         |
| Life jackets adult       | 0.72        | Kg   | 12          | 8.64         |
| Fire detectors           | 0.5         | Kg   | 4           | 2            |
| Fire extinguisher        | 9.5         | Kg   | 2           | 19           |
| Life buoy                | 3           | Kg   | 2           | 6            |
| <b>Total</b>             |             | Kg   |             | <b>40.92</b> |

| DEADWEIGHT        | Unit weight | No of units | Total weight | Total weight |
|-------------------|-------------|-------------|--------------|--------------|
| Item:             | kg          |             | kg           | ton          |
| Passengers        | 75          | 12          | 900          | 0.9          |
| Bicycle           | 18          | 12          | 216          | 0.216        |
| Stroller          | 18          | 0           | 0            | 0            |
| Wheelchair        | 225         | 0           | 0            | 0            |
| Dog               | 15          | 0           | 0            | 0            |
| <b>DEADWEIGHT</b> |             |             | <b>1116</b>  | <b>1.116</b> |

|                     |                  |      |
|---------------------|------------------|------|
| <b>DISPLACEMENT</b> | DWT/Displacement | 3.13 |
|---------------------|------------------|------|

| <b>SPACE ALLOCATION</b>            |                    |                      |
|------------------------------------|--------------------|----------------------|
|                                    | <b>Area<br/>m2</b> | <b>Volume<br/>m3</b> |
| Passenger Facilities - seating     | 4.8                | 11.52                |
| Passenger lounge standing space    | 18.72              | 44.928               |
| <b>TOTAL PASSENGER AREAS</b>       | <b>23.52</b>       | <b>56.448</b>        |
|                                    |                    |                      |
| Operation Support                  | 0.00               | 0.00                 |
| Ship Equipment                     | 1.66               | 1.12                 |
| Rescue and Fire Fighting           | 5.83               | 0.68                 |
| <b>TOTAL SHIP OUTFITTING</b>       | <b>7.49</b>        | <b>1.79</b>          |
|                                    |                    |                      |
| <b>TOTAL MACHINERY SPACES</b>      | <b>5.37</b>        | <b>6.44</b>          |
|                                    |                    |                      |
| <b>TANKS AND VOID SPACES</b>       | <b>-</b>           | <b>2</b>             |
|                                    |                    |                      |
| <b>GROSS AREA AND GROSS VOLUME</b> | <b>36.38</b>       | <b>66.68</b>         |
| <b>GROSS TONNAGE</b>               |                    | <b>2.63</b>          |

**SELECTED MAIN DIMENSIONS**

|                      |       |                             |      |
|----------------------|-------|-----------------------------|------|
| Length OA:           | 8 m   | Fm:                         | 0.23 |
| Length PP:           | 7.5 m | LWL / depl <sup>1/3</sup> : | 5.1  |
| Breadth Hull:        | 4 m   | LPP/BWL:                    | 2.5  |
| Breadth WL:          | 3 m   | BWL/T:                      | 5    |
| Draught Waterline:   | 0.6 m | CB:                         | 0.16 |
| Freeboard Deck:      | 0.6 m | CW:                         | -    |
| Freeboard:           | 0.6 m | CM:                         | -    |
| Depth to Upper Deck: | 1.2 m | CP:                         | -    |

**DECK AREAS AND VOLUMES IN HULL**

| Deck name:        | Height Above BL<br>m | Deck height<br>m | Deck area<br>m2 |
|-------------------|----------------------|------------------|-----------------|
| Keel              | 0                    | 1.2              | 4               |
| <b>TOTAL HULL</b> | <b>0</b>             | <b>1.2</b>       | <b>4</b>        |

**DECK AREAS AND VOLUMES IN SUPERSTRUCTURE**

| Deck name:              | Height Above BL<br>m | Deck height<br>m | Deck area<br>m2 |
|-------------------------|----------------------|------------------|-----------------|
| Main Deck               | 1.2                  | 2.4              | 30              |
| <b>TOTAL DECKHOUSES</b> | <b>1.2</b>           | <b>2.4</b>       | <b>30</b>       |

## SBSD Version 2

| SHIP IDENTIFICATION |                            |
|---------------------|----------------------------|
| Project:            | Autonomous Passenger Ferry |
| Project manager:    | Egil Eide, NTNU 2017       |
| Name:               | EL-len AuTomine            |

| MISSION DESCRIPTION |                                   |
|---------------------|-----------------------------------|
| Operation area:     | Ravnkloa - Fosenkaia              |
| Description:        | Regular, year round ferry service |
| Target Market       | Passenger Transport               |

| PAYLOAD CAPACITY AND PERFORMANCE |           |
|----------------------------------|-----------|
| Passenger Capacity:              | 12 People |
| Endurance:                       | 5 Min     |
| Range rundtrip:                  | 200 m     |
| Trial Speed:                     | 4 knots   |

| MACHINERY AND ROUGH POWER DEMAND |                |
|----------------------------------|----------------|
| Energy supply:                   | Li-ion Battery |
| Auxillary power:                 | Li-ion Battery |

| RULES AND REGULATIONS |           |
|-----------------------|-----------|
| Class:                | Non       |
| Flag:                 | Norwegian |
| Crew:                 | 0 persons |
| Landbased crew:       | 1 person  |

| RESTRICTIONS TO THE MAIN DIMENSIONS |     |
|-------------------------------------|-----|
| On Routes:                          | Yes |
| In Ports:                           | No  |

| PASSENGER CAPACITY I    |             |                   |                 |             |                   |
|-------------------------|-------------|-------------------|-----------------|-------------|-------------------|
| Passenger Category      | No of units | Unit Weight<br>kg | Unit Area<br>m2 | Height<br>m | Unit Volume<br>m3 |
| Person                  | 12          | 75                | 0.3             | 2.4         | 0.72              |
| Wheelchair              | 0           | 225               | 1.1             | 2.4         | 2.64              |
| Bicycle                 | 12          | 18                | 1.26            | 2.4         | 3.02              |
| Stroller                | 0           | 25                | 0.75            | 2.4         | 1.80              |
| Dog                     | 0           | 15                | 0.35            | 2.4         | 0.84              |
| <b>Total passengers</b> | <b>12</b>   | <b>1116</b>       | <b>18.72</b>    |             | <b>44.93</b>      |

| PASSENGER CAPACITY II   |             |                   |                 |             |                   |
|-------------------------|-------------|-------------------|-----------------|-------------|-------------------|
| Passenger Category      | No of units | Unit Weight<br>kg | Unit Area<br>m2 | Height<br>m | Unit Volume<br>m3 |
| Person                  | 9           | 75                | 0.3             | 2.4         | 0.72              |
| Wheelchair              | 3           | 225               | 1.1             | 2.4         | 2.64              |
| Bicycle                 |             | 18                | 1.26            | 2.4         | 3.02              |
| Stroller                |             | 25                | 0.75            | 2.4         | 1.80              |
| Dog                     |             | 15                | 0.35            | 2.4         | 0.84              |
| <b>Total passengers</b> | <b>12</b>   | <b>1350</b>       | <b>6</b>        |             | <b>14.40</b>      |

| PASSENGER CAPACITY III  |             |                   |                 |             |                   |
|-------------------------|-------------|-------------------|-----------------|-------------|-------------------|
| Passenger Category      | No of units | Unit Weight<br>kg | Unit Area<br>m2 | Height<br>m | Unit Volume<br>m3 |
| Person                  | 10          | 75                | 0.3             | 2.4         | 0.72              |
| Wheelchair              | 1           | 225               | 1.1             | 2.4         | 2.64              |
| Bicycle                 | 2           | 18                | 1.26            | 2.4         | 3.02              |
| Stroller                | 1           | 25                | 0.75            | 2.4         | 1.80              |
| Dog                     | 1           | 15                | 0.35            | 2.4         | 0.84              |
| <b>Total passengers</b> | <b>12</b>   | <b>1051</b>       | <b>7.72</b>     |             | <b>18.528</b>     |

| PASSENGER CAPACITY IV   |             |                   |                 |             |                   |
|-------------------------|-------------|-------------------|-----------------|-------------|-------------------|
| Passenger Category      | No of units | Unit Weight<br>kg | Unit Area<br>m2 | Height<br>m | Unit Volume<br>m3 |
| Person                  | 10          | 75                | 0.3             | 2.4         | 0.72              |
| Wheelchair              | 1           | 225               | 1.1             | 2.4         | 2.64              |
| Bicycle                 | 5           | 18                | 1.26            | 2.4         | 3.02              |
| Stroller                | 1           | 25                | 0.75            | 2.4         | 1.80              |
| Dog                     | 0           | 15                | 0.35            | 2.4         | 0.84              |
| <b>Total passengers</b> | <b>12</b>   | <b>1090</b>       | <b>11.15</b>    |             | <b>26.76</b>      |



| PASSENGER CAPACITY V    |             |                   |                 |             |                   |
|-------------------------|-------------|-------------------|-----------------|-------------|-------------------|
| Passenger Category      | No of units | Unit Weight<br>kg | Unit Area<br>m2 | Height<br>m | Unit Volume<br>m3 |
| Person                  | 12          | 75                | 0.3             | 2.4         | 0.72              |
| Wheelchair              | 0           | 225               | 1.1             | 2.4         | 2.64              |
| Bicycle                 | 0           | 18                | 1.26            | 2.4         | 3.02              |
| Stroller                | 0           | 25                | 0.75            | 2.4         | 1.80              |
| Dog                     | 0           | 15                | 0.35            | 2.4         | 0.84              |
| <b>Total passengers</b> | 12          | 900               | 3.6             |             | 8.64              |

| LOADING CAPACITY        |             |                   |                 |             |                   |
|-------------------------|-------------|-------------------|-----------------|-------------|-------------------|
| Passenger Category      | No of units | Unit Weight<br>kg | Unit Area<br>m2 | Height<br>m | Unit Volume<br>m3 |
| Person                  | 9           | 75                | 0.3             | 2.4         | 0.72              |
| Wheelchair              | 3           | 225               | 1.1             | 2.4         | 2.64              |
| Bicycle                 | 0           | 18                | 1.26            | 2.4         | 3.02              |
| Stroller                | 0           | 25                | 0.75            | 2.4         | 1.80              |
| Dog                     | 0           | 15                | 0.35            | 2.4         | 0.84              |
| Luggage                 | 12          | 30                |                 |             |                   |
| <b>Total passengers</b> | 12          | 1710              | 6               |             | 9.02              |

| PASSENGER SPACES           |       |         |        | Height     | Area | Volume |
|----------------------------|-------|---------|--------|------------|------|--------|
| Name/Use of space          | Seats | m2/seat | m2/pax | m          | m2   | m3     |
| Lounge                     | 12    | 0.4     | 0.4    | 2.4        | 4.8  | 11.52  |
| Passenger Public Spaces    |       |         |        | 0.4 m2/pax | 4.8  | 11.52  |
| TOTAL PASSENGER FACILITIES |       |         | 0.4    | m2/pax     | 4.8  | 11.52  |

| SHIP EQUIPMENT                     |        |                 |              |             | Covered         | Covered           |
|------------------------------------|--------|-----------------|--------------|-------------|-----------------|-------------------|
| (Use pr pc)<br>Name/Use of deck:   | Number | Unit Area<br>m2 | Covered<br>% | Height<br>m | Unit area<br>m2 | Unit Volume<br>m3 |
| Sensors to see surroundings        | 6      | 0.008           | 0            | 0.07        | 0.00            | 0.00              |
| Cable storage                      | 2      | 0.150           | 100          | 2.40        | 0.15            | 0.36              |
| Computer                           | 1      | 1.200           | 100          | 0.25        | 1.20            | 0.30              |
| Surveillance                       | 2      | 0.035           | 100          | 0.08        | 0.04            | 0.00              |
| Air vent                           | 2      | 0.035           | 50           | 2.00        | 0.02            | 0.04              |
| Ramp for boarding                  | 2      | 0.075           | 0            | 1.00        | 0.00            | 0.00              |
| Hydraulic sylinder                 | 4      | 0.044           | 0            | 0.05        | 0.00            | 0.00              |
| Bilge pump in Battery room         | 2      | 0.100           | 100          | 0.25        | 0.10            | 0.03              |
| Emergency Bilge Pump               | 2      | 0.100           | 100          | 0.25        | 0.10            | 0.03              |
| Information screen                 | 2      | 0.028           | 100          | 0.33        | 0.03            | 0.00924           |
| <b>Total ship equipment spaces</b> |        | 2.47            |              |             | 2.06            | 1.22              |

| RESCUE AND FIREFIGHTING                      |                 |                 |              |             | Covered         | Covered           |
|--|-----------------|-----------------|--------------|-------------|-----------------|-------------------|
| Name/Use of Deck:                            | Number<br>Units | Unit Area<br>m2 | Covered<br>% | Height<br>m | unit area<br>m2 | unit Volume<br>m3 |
| Life jackets child                           | 12              | 0.18            | 100          | 0.10        | 0.18            | 0.02              |
| Life jackets adult                           | 12              | 0.23            | 100          | 0.12        | 0.23            | 0.03              |
| Fire detectors                               | 4               | 0.0001          | 100          | 0.05        | 0.00            | 0.00              |
| Fire extinguisher                            | 2               | 0.02            | 100          | 0.50        | 0.02            | 0.01              |
| Life buoy                                    | 2               | 0.44            | 100          | 0.13        | 0.44            | 0.06              |
| <b>Total rescue and fire fighting spaces</b> |                 | 5.83            |              |             | 5.83            | 0.68              |

|                              |  |      |  |  |      |      |
|------------------------------|--|------|--|--|------|------|
| <b>TOTAL SHIP OUTFITTING</b> |  | 8.30 |  |  | 7.89 | 1.89 |
|------------------------------|--|------|--|--|------|------|

|                                     |                |        |         |
|-------------------------------------|----------------|--------|---------|
| Machinery Type                      | Electric drive |        |         |
| No of pods                          | 2              |        |         |
| Season                              | Mid            | High   | Weekend |
| Speed                               | 4 kn           | 4 kn   | 4 kn    |
| Input propulsion power (pr pod)     | 4.2 kW         | 4.2 kW | 4.2 kW  |
| Installed propulsion power (pr pod) | 26 kWh         | 26 kWh | 26 kWh  |
| Range before charging (pr pod)      | 6.2 h          | 6.2 h  | 6.2 h   |
| Extra power (pr pod)                | 0 kWh          | 0 kWh  | 0 kWh   |
| Number of battery modules in total  | 2 pc           | 2 pc   | 2 pc    |
| Total installed power               | 52 kWh         | 52 kWh | 52 kWh  |

| ROOMS                                | Height<br>m | Area<br>m2 | Volume<br>m3 |
|--------------------------------------|-------------|------------|--------------|
| Name/ Use of Space:                  |             |            |              |
| Pump room, bilge (2 units)           | 1           | 1.40       | 1.40         |
| Thruster room (2 units)              | 1.2         | 3.15       | 3.78         |
| Fire fighting room (NOVEC) (2 units) | 1           | 0.25       | 0.25         |
| Emergency bilge pump (2 units)       | 1           | 0.40       | 0.40         |
| Anchor incl Rope (2 units)           | 1           | 0.70       | 0.70         |
| Hydraulic aggr. Room (2 units)       | 1           | 2.40       | 2.40         |
| Battery room (2 stk)                 | 1           | 12.80      | 12.80        |
| Technical spaces                     |             | 21.10      | 21.73        |

| TANKS AND VOIDS       | Consump.<br>g/kWh | Consump.<br>ton/day | Range<br>nm | Endurance<br>days | Margin<br>factor | Volume<br>m3 |
|-----------------------|-------------------|---------------------|-------------|-------------------|------------------|--------------|
| Name/ Use of space:   |                   |                     |             |                   |                  |              |
| Voids                 |                   |                     |             |                   |                  | 0            |
| Tanks and Void Spaces |                   |                     |             |                   |                  | 0            |

| LIGHTWEIGHT              |    |             |             |              |              |
|--------------------------|----|-------------|-------------|--------------|--------------|
|                          |    | Unit weight | No of units | Total weight | Total weight |
|                          |    | kg          |             | kg           | ton          |
| Ramp for boarding        |    | 126         | 2           | 252          | 0.252        |
| Fence                    |    | 129         | 2           | 258          | 0.258        |
| Superstructure           |    | 1084        | 1           | 1084         | 1.084        |
| Ship outfitting          |    | 184         | 1           | 184          | 0.184        |
| Anchor incl rope         |    | 30          | 2           | 60           | 0.06         |
| Battery module           |    | 591         | 2           | 1182         | 1.182        |
| NOVEC 1230 System 5 l    |    | 6.75        | 4           | 27           | 0.027        |
| NOVEC 1230 System 16 l   |    | 31          | 2           | 62           | 0.062        |
| Cooling system           |    | 25          | 1           | 25           | 0.025        |
| Emergency Bilge pump     |    | 1.5         | 2           | 3            | 0.003        |
| Thruster system          |    | 50          | 2           | 100          | 0.1          |
| Strength elements        |    | 1032        | 1           | 1032         | 1.032        |
| Hull structure           |    | 590         | 1           | 590          | 0.59         |
| Hydr. Aggr. Inkl oil     |    | 30          | 2           | 60           | 0.06         |
| Bilge pump               |    | 1.5         | 4           | 6            | 0.006        |
| Safety/ Rescue equipment |    | 41          | 1           | 41           | 0.041        |
| Main Deck                |    | 415         | 1           | 415          | 0.415        |
| <b>Total</b>             | GV |             |             | 5380.9       | 5.38         |
| <b>Reserve</b>           | %  | 1.0 %       |             |              | 0.05         |
| <b>LIGHTWEIGHT</b>       | GV |             |             |              | 5.43         |

| SHIP OUTFITTING    | Unit weight | Unit | No of units | Total weight |
|--------------------|-------------|------|-------------|--------------|
| Sensors            | 30          | Kg   | 1           | 30           |
| Cable storage      | 10          | Kg   | 1           | 10           |
| Computer           | 25          | Kg   | 1           | 25           |
| Surveillance       | 0.5         | Kg   | 2           | 1            |
| Air vent           | 25          | Kg   | 2           | 50           |
| Hydraulic sylinder | 5           | Kg   | 4           | 20           |
| Information screen | 6           | Kg   | 2           | 12           |
| Seats              | 3           | Kg   | 12          | 36           |
| <b>Total</b>       |             | Kg   |             | <b>184</b>   |

| SAFETY/ RESCUE EQUIPMENT | Unit weight | Unit | No of units | Total weight |
|--------------------------|-------------|------|-------------|--------------|
| Life jackets child       | 0.44        | Kg   | 12          | 5.28         |
| Life jackets adult       | 0.72        | Kg   | 12          | 8.64         |
| Fire detectors           | 0.5         | Kg   | 4           | 2            |
| Fire extinguisher        | 9.5         | Kg   | 2           | 19           |
| Life buoy                | 3           | Kg   | 2           | 6            |
| <b>Total</b>             |             | Kg   |             | <b>40.92</b> |

| DEADWEIGHT        |      |                   |             |                    |                     |
|-------------------|------|-------------------|-------------|--------------------|---------------------|
| Item:             | Unit | Unit weight<br>kg | No of units | Total weight<br>kg | Total weight<br>ton |
| Passengers        | No   | 75                | 12          | 900                | 0.9                 |
| Bicycle           | No   | 18                | 0           | 0                  | 0                   |
| Stroller          | No   | 18                | 0           | 0                  | 0                   |
| Wheelchair        | No   | 225               | 3           | 675                | 0.675               |
| Dog               | No   | 15                | 0           | 0                  | 0                   |
| Luggage           | No   | 30                | 12          | 360                | 0.36                |
| <b>DEADWEIGHT</b> |      |                   |             | <b>1935</b>        | <b>1.935</b>        |

| DISPLACEMENT |                  |      |
|--------------|------------------|------|
|              | DWT/Displacement | 7.37 |

| Element                    | Unit weight [ton] | # units in total | Total weight [ton] |
|----------------------------|-------------------|------------------|--------------------|
| Frame side                 | 0.0210            | 27               | 0.567              |
| Frame bottom               | 0.0079            | 27               | 0.213              |
| Longitudinal bottom girder | 0.0842            | 1                | 0.084              |
| Deck beam longitudinal     | 0.0241            | 5                | 0.121              |
| Knee plate                 | 0.0016            | 27               | 0.044              |
| Knee plate keel            | 0.0001            | 27               | 0.003              |
| Ladder on hull side        | 0.0020            | 2                | 0.004              |
| <b>TOTAL WEIGHT</b>        |                   |                  | <b>1.036</b>       |

| Element                    | Vol     | Density [t/m3] |
|----------------------------|---------|----------------|
| Frame side                 | 0.008   | 2.7            |
| Frame bottom               | 0.003   | 2.7            |
| Longitudinal bottom girder | 0.031   | 2.7            |
| Deck beam longitudinal     | 0.009   | 2.7            |
| Knee plate                 | 0.001   | 2.7            |
| Knee plate keel            | 0.00005 | 2.7            |

| SPACE ALLOCATION                |              |             |
|---------------------------------|--------------|-------------|
|                                 | Area         | Volume      |
|                                 | m2           | m3          |
| Passenger Facilities - seating  | 4.8          | 11.5        |
| Passenger lounge standing space | 18.72        | 44.9        |
| <b>TOTAL PASSENGER AREAS</b>    | <b>23.52</b> | <b>56.4</b> |

|                              |             |             |
|------------------------------|-------------|-------------|
| Operation Support            | 0.00        | 0.00        |
| Ship Equipment               | 2.06        | 1.22        |
| Rescue and Fire Fighting     | 5.83        | 0.68        |
| <b>TOTAL SHIP OUTFITTING</b> | <b>7.89</b> | <b>1.89</b> |

|                               |              |              |
|-------------------------------|--------------|--------------|
| <b>TOTAL MACHINERY SPACES</b> | <b>21.10</b> | <b>21.73</b> |
|-------------------------------|--------------|--------------|

|                              |          |          |
|------------------------------|----------|----------|
| <b>TANKS AND VOID SPACES</b> | <b>-</b> | <b>0</b> |
|------------------------------|----------|----------|

|                                    |              |              |
|------------------------------------|--------------|--------------|
| <b>GROSS AREA AND GROSS VOLUME</b> | <b>52.51</b> | <b>80.07</b> |
| <b>GROSS TONNAGE</b>               |              | <b>3.25</b>  |



| SELECTED MAIN DIMENSIONS |       |   |                                  |
|--------------------------|-------|---|----------------------------------|
| Length OA:               | 9     | m | Fn: 0.22                         |
| Length PP:               | 8.85  | m | LWL / depl <sup>1/3</sup> : 4.55 |
| Breadth Hull:            | 4     | m | LPP/BWL: 2.44                    |
| Breadth WL:              | 3.63  | m | BWL/T: 7.05                      |
| Draught Waterline:       | 0.515 | m | CB: 0.45                         |
| Freeboard Deck:          | 0.685 | m | CW: 0.78                         |
| Freeboard:               | 0.685 | m | CM: 0.60                         |
| Depth to Upper Deck:     | 1.2   | m | CP: 0.75                         |

| DECK AREAS AND VOLUMES IN HULL |                      |                  |                 |
|--------------------------------|----------------------|------------------|-----------------|
| Deck name:                     | Height Above BL<br>m | Deck height<br>m | Deck area<br>m2 |
| Keel                           | 0                    | 1.2              | 4               |
| <b>TOTAL HULL</b>              | <b>0</b>             | <b>1.2</b>       | <b>4</b>        |

| DECK AREAS AND VOLUMES IN SUPERSTRUCTURE |                      |                  |                 |
|--|----------------------|------------------|-----------------|
| Deck name:                               | Height Above BL<br>m | Deck height<br>m | Deck area<br>m2 |
| Main Deck                                | 1.2                  | 2.4              | 30.8            |
| <b>TOTAL DECKHOUSES</b>                  | <b>1.2</b>           | <b>2.4</b>       | <b>30.8</b>     |

| <b>Component</b>              | <b>SBSD Version</b> | <b>Referance</b>                          |
|-------------------------------|---------------------|---|
| Sensors - Velodyne 16 LIDAR   | 1&2                 | (Velodyne Lidar, 2017)                    |
| Hydraulic sylinder, S = 0.7 m | 1&2                 | (TAON, 2017a)                             |
| Tv screen                     | 1&2                 | (Lefdal, 2017)                            |
| Battery room, Torqueedo       | 1                   | (Torqueedo, 2017)                         |
| Battery room, PBES            | 2                   | (Plan B Energy Storage, 2017)             |
| Life jackets                  | 1&2                 | (Clas Ohlson, 2017a) (Clas Ohlson, 2017b) |
| Fire extinguisher             | 1&2                 | (Jula, 2017)                              |
| Life buoy                     | 1&2                 | (BestMarin, 2017)                         |
| Fire detector                 | 1&2                 | (Røde Kors, 2017b)                        |
| Bilgepump                     | 1&2                 | (Xylem Water Solutions, 2017)             |
| Hyralic pump                  | 1&2                 | (TAON, 2017b)                             |
| Weight hydraulic pump         | 1&2                 | (Wee Gruppen, 2017)                       |
| Hull weight                   | 1                   | (Ms Boat, 2017)                           |
| Size CO2 tank                 | 1                   | (Røde Kors, 2017a)                        |
| Weight life buoy              | 1&2                 | (Maritim Båtutstyr, 2017)                 |
| Size NOVEC                    | 2                   | (Engebø, 2017) (3M, 2017)                 |
| Weight bicycle                | 1&2                 | (Bikeshop, 2017)                          |
| weight stroller               | 1&2                 | (Jollyroom, 2017)                         |
| Weight wheelchair             | 1&2                 | (Hjelpemiddeldatabasen, 2017)             |
| Weight dog                    | 1&2                 | (Rasehund, 2017)                          |

## Bibliography

- 3M (2017). Noves 1230 - fire protection fluid. Personal Communication. Retrieved: 03.05.2017.
- BestMarin (2017). Livbøye m/kasteline - rina godkjent, orange. <https://www.bestmarin.no/produkter/sikkerhetsutstyr/livboeyer/livboeye-m-kasteline---rina-godkjent--orange-p1022943>. Retrieved: 24.05.2017.
- Bikeshop (2017). Kross moderato citysykkel. <https://bikeshop.no/komplette-sykler/komplette-sykler/citysykler/kross/kross-moderato-citysykkel-hvit-26-3-gir-v-brems-175kg-ny137157-p0000072857>. Retrieved: 24.05.2017.
- Clas Ohlson, . (2017a). Baltic 1240 redningsvest, barn. <http://www.clasohlson.com/no/Baltic-1240-redningsvest./Pr310894002>. Retrieved: 24.05.2017.
- Clas Ohlson, . (2017b). Baltic 1240 redningsvest, voksen. <http://www.clasohlson.com/no/Baltic%201240%20redningsvest./Pr310894002>. Retrieved:24.05.2017.
- Engebø, M. (2017). Datasheet kidde cylinder. Personal Communication. Retrieved: 03.05.2017.
- Hjelpemiddeldatabasen (2017). Chasswheel. <http://www.hjelpemiddeldatabasen.no/r11x.asp?linkinfo=28945>. Retrieved: 24.05.2017.
- Jollyroom (2017). Baby jogger city mini gt single black. <http://www.jollyroom.no/barnevogner/triller/triller/baby-jogger-city-mini-gt-single-black-black>. Retrieved: 24.05.2017.
- Jula (2017). Pulverbrannslukningsapparat 6 kg. <http://www.jula.no/catalog/hjem-og-husholding/brann-og-sikkerhet/merke/brannslukningsapparater/pulverbrannslukningsapparat-442051/>. Retrieved: 24.05.2017.
- Lefdal (2017). Lenovo thinkvision t2424p 23,8" skjerm. <https://www.lefdal.com/product/data/pc-skjerm/LE60F7MAT1EU/lenovo-thinkvision-t2424p-23-8-skjerm-sort>. Retrieved: 24.05.2017.

- Maritim Båtutstyr, . (2017). Livbøye godkjent 75cm. <https://www.maritim.no/livboeye-godkjent-75cm#.WSWdLWjyg2x>. Retrieved: 24.05.2017.
- Ms Boat, . (2017). Cwa 800 wt. <http://msboat.com/our-boats/cwa-800-wt/>. Retrieved: 24.05.2017.
- Plan B Energy Storage, . (2017). Personal communication. Retrieved: 24.04.2017.
- Rasehund (2017). Golden retriever. <http://www.rasehund.no/raser/rase.asp?unit=306>. Retrieved: 24.05.2017.
- Røde Kors, . (2017a). Co2 brannslukkingsapparat 5 kg. [http://www.rodekorsforstehjelp.no/display.aspx?menuid=28&prodid=2896&gclid=CjwKEAjwzKPGBRCS550e46q9hCkSJAAMvVuMeyBVW-\\_TJ0-zqeG0caIT9rJUJ8Z\\_z5WTOakXkeb4gBoChkjw\\_wcB](http://www.rodekorsforstehjelp.no/display.aspx?menuid=28&prodid=2896&gclid=CjwKEAjwzKPGBRCS550e46q9hCkSJAAMvVuMeyBVW-_TJ0-zqeG0caIT9rJUJ8Z_z5WTOakXkeb4gBoChkjw_wcB). Retrieved: 24.05.2017.
- Røde Kors, . (2017b). Deltronic brannvarsler trådløs. [http://www.rodekorsforstehjelp.no/display.aspx?menuid=27&prodid=2&gclid=CjwKEAiAuc\\_FBRD7\\_JCM3NSY92wSJABbVoxB2CM9nBf-dgCZBGDMc3QS93hI\\_p-QBHg5IPfoYf5whhoC3MXw\\_wcB](http://www.rodekorsforstehjelp.no/display.aspx?menuid=27&prodid=2&gclid=CjwKEAiAuc_FBRD7_JCM3NSY92wSJABbVoxB2CM9nBf-dgCZBGDMc3QS93hI_p-QBHg5IPfoYf5whhoC3MXw_wcB). Retrieved: 24.05.2017.
- TAON (2017a). Fastøye: Ø40/25. <https://taon.dk/no/dobbeltvirkende-fastoeye-80/fastoeye-oe40-25-p991>. Retrieved: 24.05.2017.
- TAON (2017b). M1/1258 (24 volt). <https://taon.dk/no/mobile-12v-24v-20/m1-1258-24-volt-p1957>. Retrieved: 24.05.2017.
- Torqueedo (2017). Electric boating - product catalogue. <http://media.torqueedo.com/catalogs/torqueedo-catalog-2017-en.pdf>. Retrieved: 23.05.2017.
- Velodyne Lidar, . (2017). Puck vlc-16. <http://velodynelidar.com/vlp-16.html>. Retrieved: 23.05.2017.
- Wee Gruppen, . (2017). 24v dobbeltvirkende hydr.aggreat - 20d21-001. [http://www.wee.no/index.cfm?tmpl=butikk&a=product\\_inline&&b\\_kid=1263533&b\\_id=1667177](http://www.wee.no/index.cfm?tmpl=butikk&a=product_inline&&b_kid=1263533&b_id=1667177). Retrieved: 24.05.2017.
- Xylem Water Solutions, . (2017). Rule 1500 submersible. <https://www.jabscoshop.com/marine/pumps/rule-submersible-pumps-accessories/rule-bilge-pumps/03-rule-1500-submersible.htm>. Retrieved: 02.05.2017.

## C.8 Power Demand of Propulsion System Based on Torquedo

### Pod

Cruise 10.0

Input = 10 kW @ max speed

Speed = 17,3 kn

Time 55 min = 0,917 h

Input  $\times$  time = battery power

$x \times 6,5 \text{ h} = 10,74 \text{ kWh}$

$\uparrow$   
range at speed 3,8 kn

$\Rightarrow x = 1,7 \text{ kW}$

Our vessel speed = 4,0 kn

$\Rightarrow$  We use 2,5 kW (assumed)

Battery pack for Cruise 10.0 provide 10,74 kWh  
This gives  $\frac{10,74}{2,5} = 4,296 \text{ h}$  of operation

before batteries are empty

Add 10% margin for temperature change etc.

$2,5 \text{ kW} \times (\text{operational hours} + 10\%) = 10,74 \text{ kWh}$

$\Rightarrow$  Op. time = 4,2 h

= 4 h and 12 min per pod

## D Appendix: Hull and Superstructure

### D.1 Starting plate in Deftship

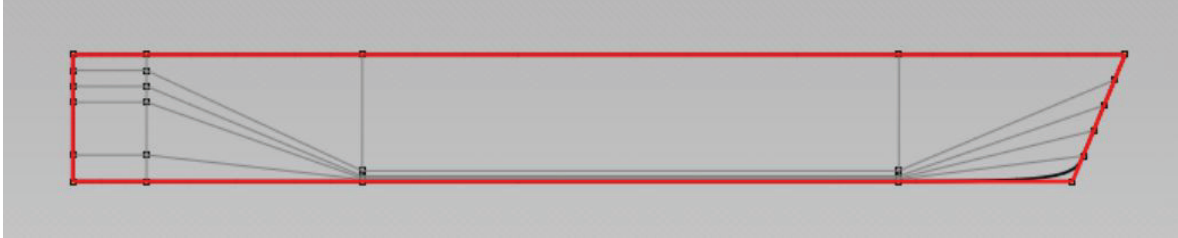

### D.2 Model With and Without Raised Bow

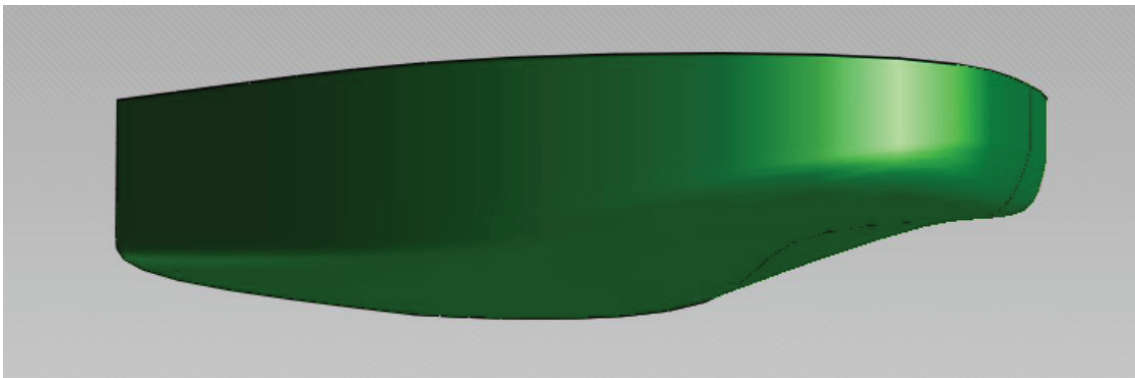
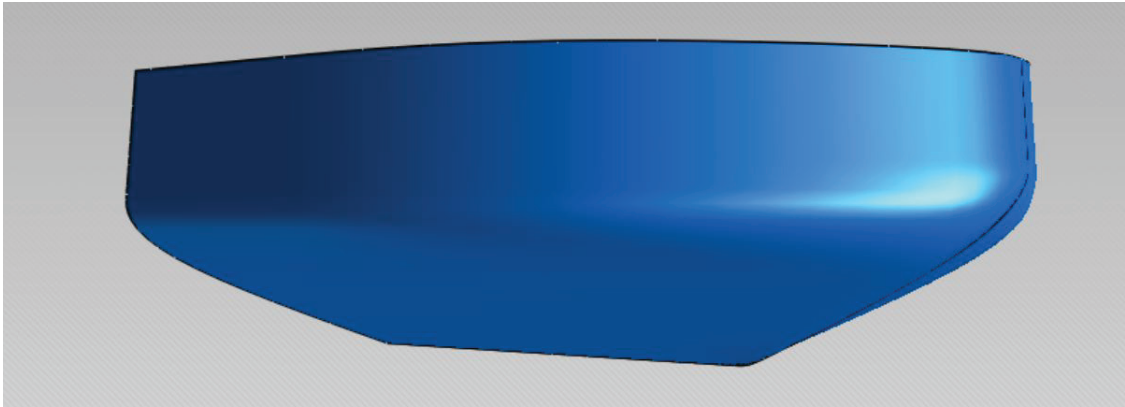

### D.3 Hull Profile in Delftship

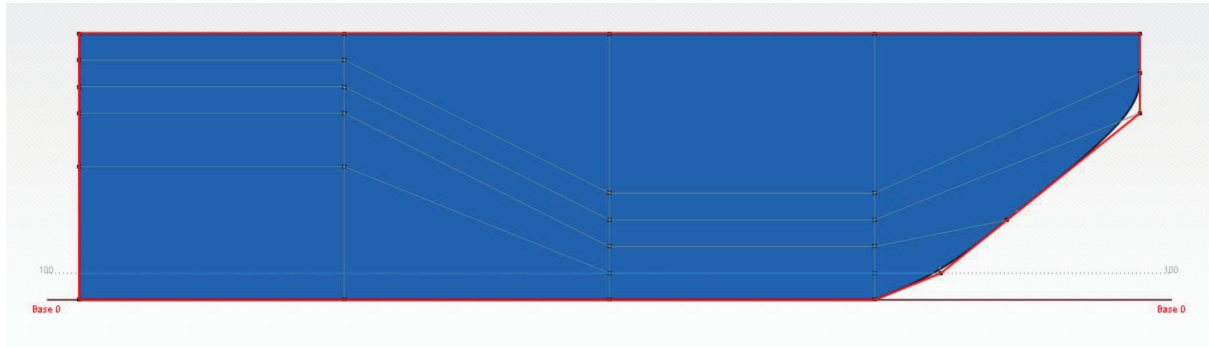

### D.4 Curved Surface

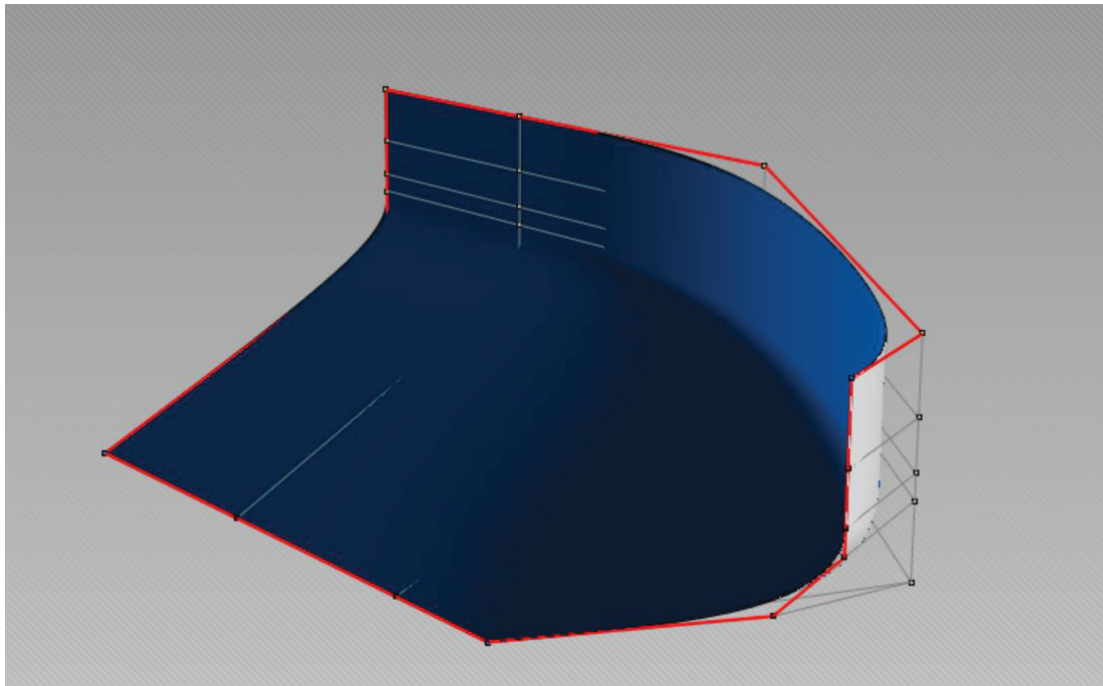

## D.5 Sketches of Superstructure Designs

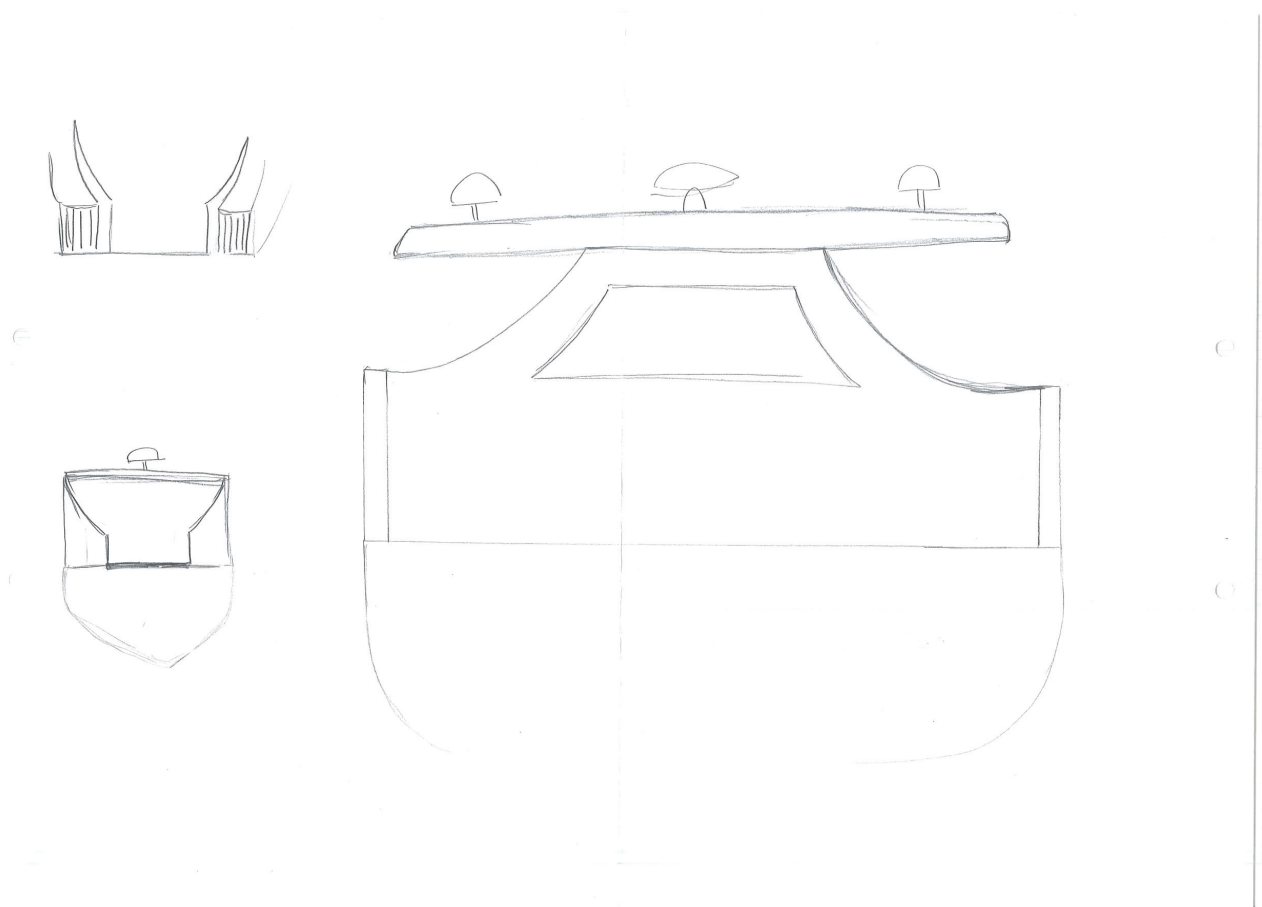



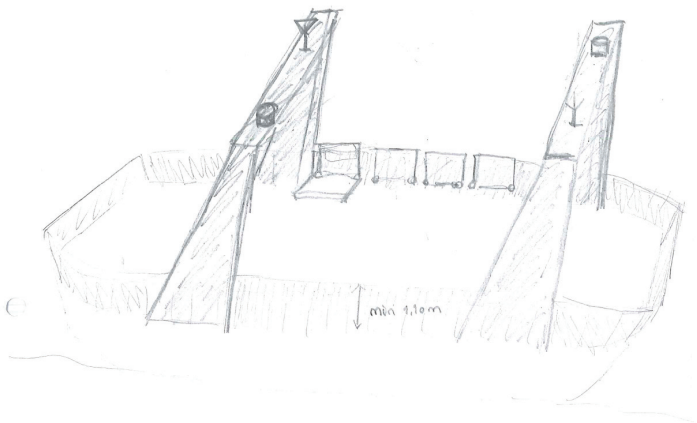

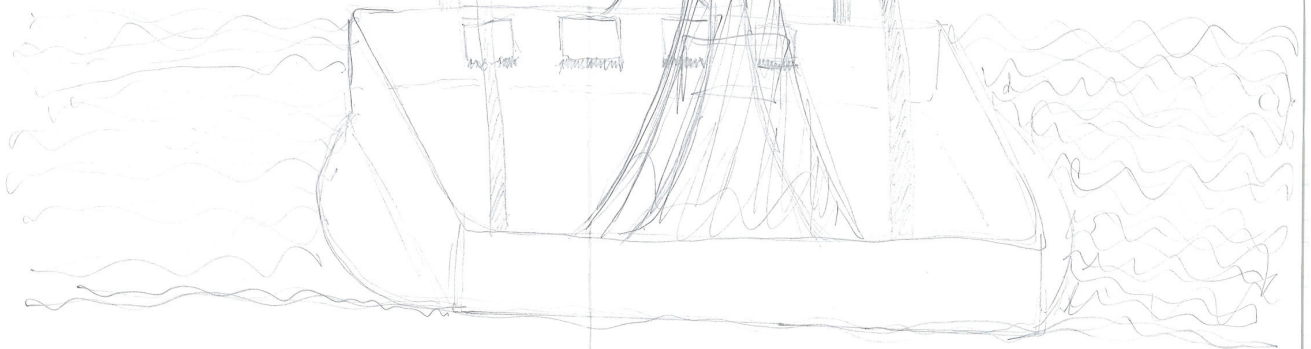
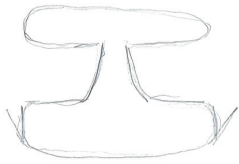

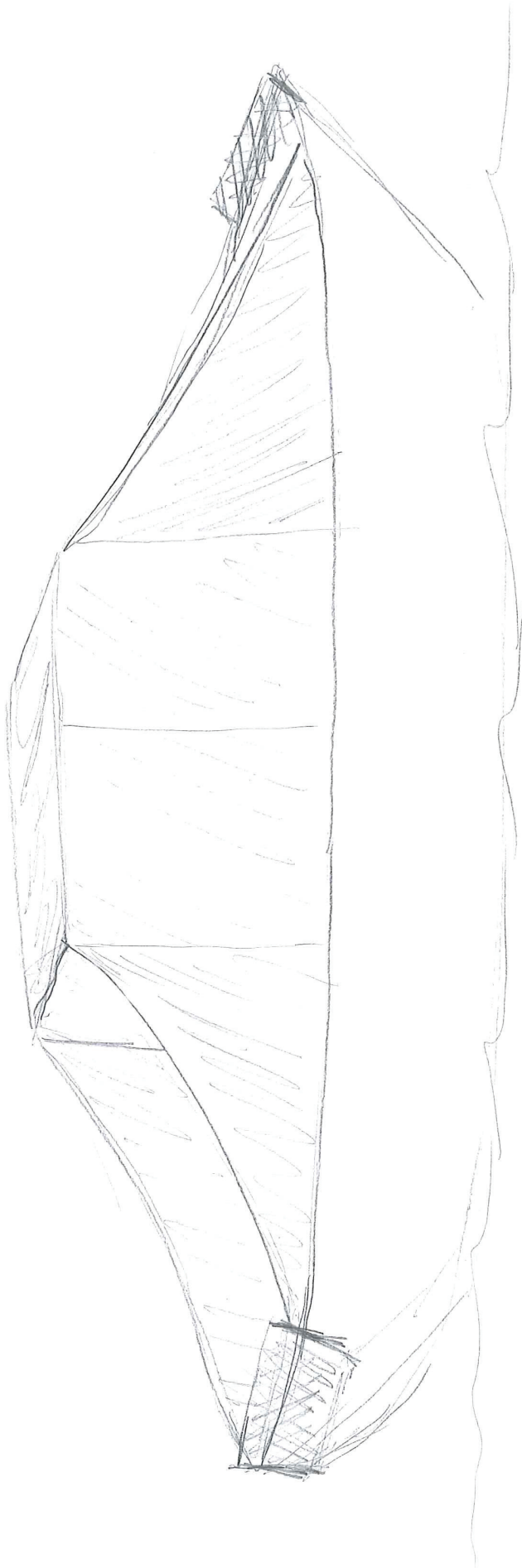

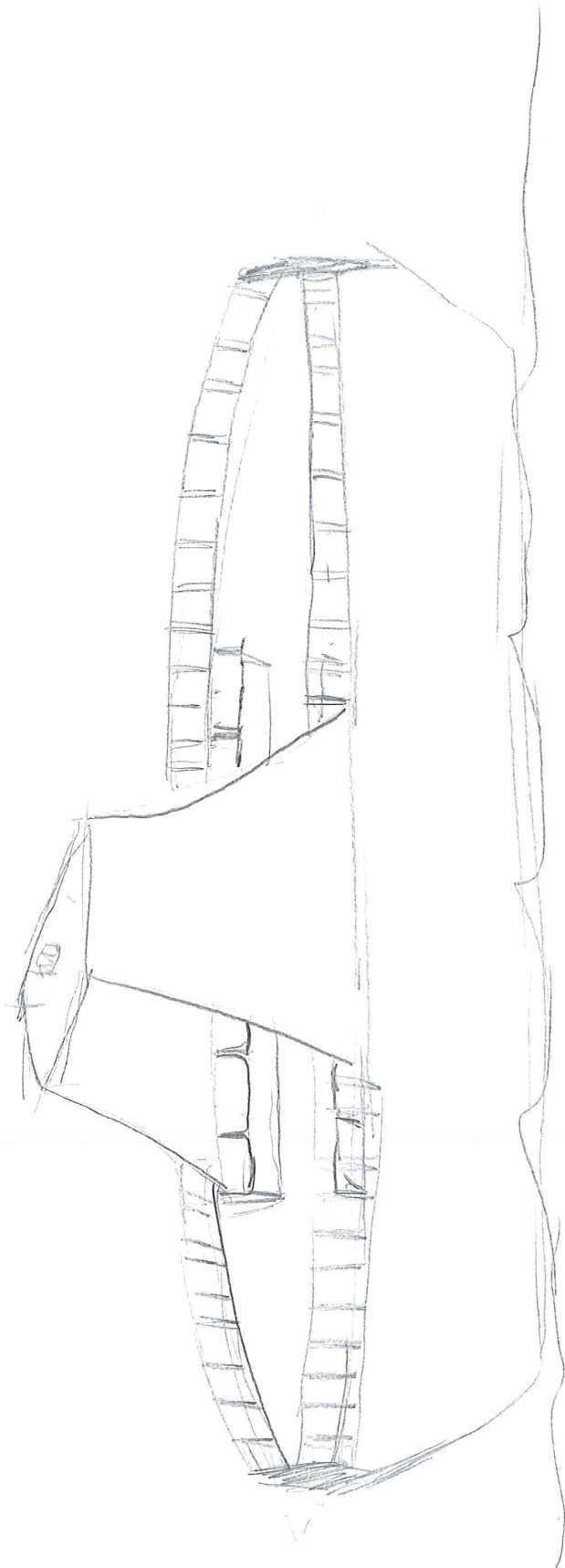



## D.6 Notes from Meeting with PBES

### Meeting With PBES

Date: 24.04.2017

#### **Batteries**

Build up by battery cells and build together to modules.

The modules are 90 kg.

75/80 Ampere and 100 V per module.

Stacked together and coupled to a control board.

Today the smallest module amount delivered is 500 V, but they can modify the system to deliver even smaller packs.

Stacked in height, so there can be space for 2 modules in height in the autonomous ferry.

The cells have about 10 years lifetime.

For small batteries, the price can be 700 dollars per kWh. (Special price for us).

#### **Maintenance**

For maintenance, the modules shall be pulled forward, there should therefore be space for maintenance in front/middle.

Requirement for maintenance:

- Control once a year to example change the seals for the water cooling and conduct a regular check.

#### **Charging**

Not more than 50 kW.

1C = 1 discharge per hour

2C = 2 discharges per hour

The «nicer» charging and discharging, the longer lifetime for the batteries.

The charging electricity is design rewarding.

PBES needs to know size per cycle

- Max charge [kW]
- Max discharge

Normally the discharging factor is max 2C, but can be even higher in some situations.

#### **Optimal charging**

Small charging intervals is most optimal.

DOD = death of discharge

Se picture at the end of this meeting note.

#### **Cooling:**

Heat exchanger.

To know how much cooling which is desired PBES needs to know a load profile for the ferry to estimate the desired cooling effect.

The batteries are water cooled. Ionised water, can't use seawater due to corrosion.

The cooling water should be 18 [Degrees Celsius] +/- 3. May not be a problem to keep it cold enough, but may need a heater to keep the water 18 [Degrees Celsius].

The cooling system needs circulation pumps (24 Volt), maybe two because of redundancy. In addition, temperature and pressure sensors. No expansion tank is needed, not so high temperature differences.

The loss in low temperature will not be a problem when you keep the cooling water 18 [Degrees Celsius].

The water needs to be hold at this level to ensure lifetime and safety of the battery cells. In addition will the cooling water keep dangerous situations under control, and avoid dangerous gas. In an emergency will the leakage of gas be 800 mL per cell.

### Storage:

Avoid freezing.

Within the ferry is ready there will be useable glykol in the market. Glykol increases microsimsens.

### Firefighting:

Recommends inergen gas. They are unsure if Sjøfartsdirektoratet agree to this.

Fog extinguisher.

CO2 is a possibility, but there are better solutions in the market.

Extinguishing with water is a bad idea because of the demand for a tank with fresh water.

In addition there needs to be fire isolation → A60 (another name today)

Look at fire classes.

### Additional parts:

Cooling system (pumps, sensors)

DC chopper (2 strings and 2 choppers)

- Recommend Vacom or ABB
- The test ferry has Mastervolt, but may not be optimal for the ferry.

Shipnet power supply

### Fastening:

Needs to be fasten in bottom and top.

In bottom: Screwed or welded into the bottom. Rubber mat and screws for aluminium ferry.

At top: Screwed (needs to be solid)

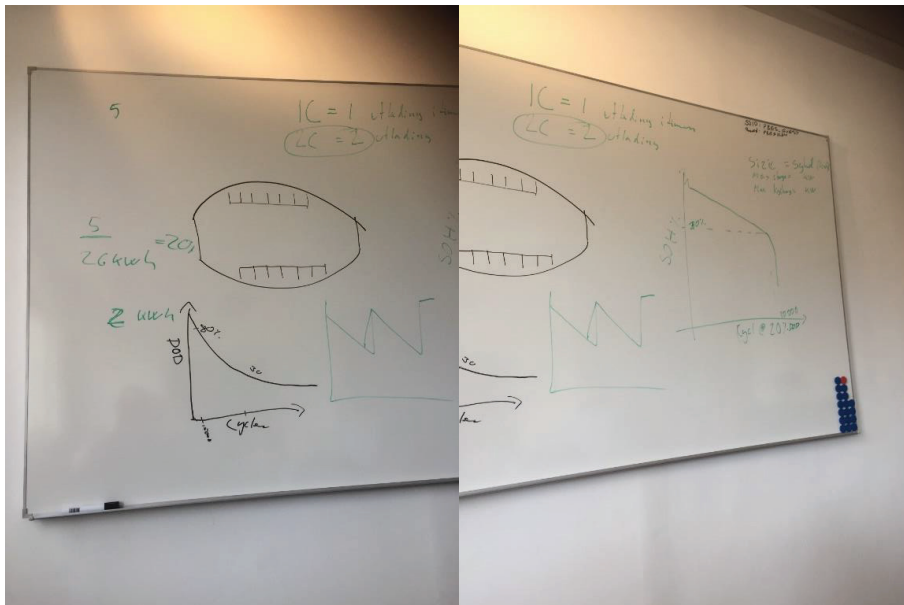

## D.7 Calculation of Novec Amount for Fire Fighting

### NOVEC

From example project, NORTRONIC:

$$\text{Room volume} = 29,64 \text{ m}^3$$

$$\text{Required NOVEC amount} = 43,10 \text{ kg}$$

Used 44 kg  
→ Round up!

$$\Rightarrow \text{Novec/volume ratio} = \frac{43,10}{29,64} \approx 1,45 \text{ kg/m}^3$$

### OUR VESSEL

$$\text{Battery room volume} = 6,4 \text{ m}^3$$

$$\text{Hydr. generator room volume} = 1,2 \text{ m}^3$$

$$\text{Thruster room volume} = 1,9 \text{ m}^3$$

Required NOVEC:

$$\text{Battery room} = 6,4 \times 1,45 = 9,28 \text{ kg}$$

$$\text{Hydr. Gen. room} = 1,2 \times 1,45 = 1,74 \text{ kg}$$

$$\text{Thruster room} = 1,9 \times 1,45 = 2,8 \text{ kg}$$

NOVEC used/installed:

$$\text{Batt. room} = 10 \text{ kg}$$

$$\text{Hydr. gen room} = 3 \text{ kg}$$

$$\text{Thruster room} = 3 \text{ kg}$$

Tank size

16 litres

5 litres

5 litres

Tank weight:

↑

3 kg is the minimum

$$\text{Batt. room} = 10 \cdot 0,75 = 12 \text{ kg}$$

$$\text{Hydr. gen room} = 5 \cdot 0,75 = 3,75 \text{ kg}$$

$$\text{Thruster room} = 3,75 \text{ kg}$$

Tank weight/volume ratio

$$= 61 \text{ kg} / 81 \text{ litres}$$

$$= 0,75 \text{ kg/litres}$$

From example.



## NOVEC - New calculation

$$\text{NOVEC/volume ratio} = 1,45 \text{ kg/m}^3$$

$$\text{Tank weight/volume ratio} = 0,75 \text{ kg/litre}$$

$$\text{Battery room} = 10 \text{ kg}$$

$$= \left( \begin{array}{l} \uparrow \\ 16 \text{ litres tank} \\ \uparrow \end{array} \right.$$

$$= 10 + 12 \text{ kg} = 22 \text{ kg total weight}$$

### Thruster- and equipment room?

$$\text{Req. NOVEC} = 1,45 \times 8 = 11,6 \text{ kg}$$

$$\text{Used amount} = 12 \text{ kg}$$

$$= 16 \text{ litres tank}$$

$$= 12 + 12 = 24 \text{ kg total weight}$$

## D.8 Anchor Dimensions set by Nordic Boat Standard

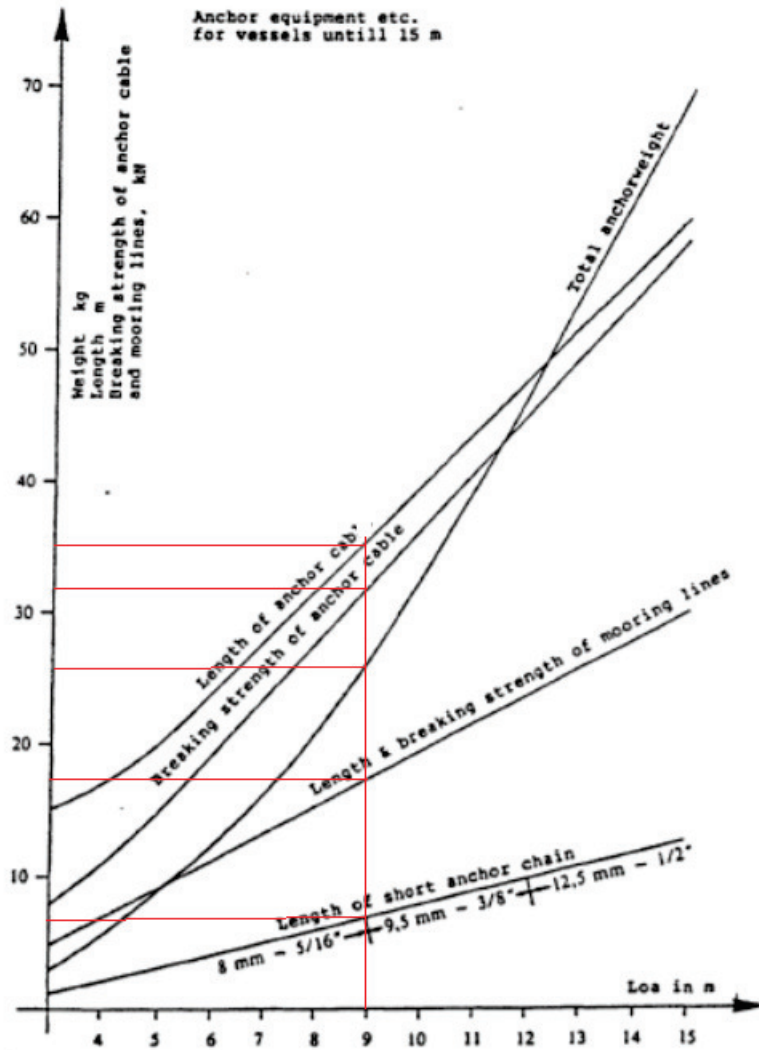

## D.9 Sketches of Arrangement Below Deck

### First Arrangement Sketch

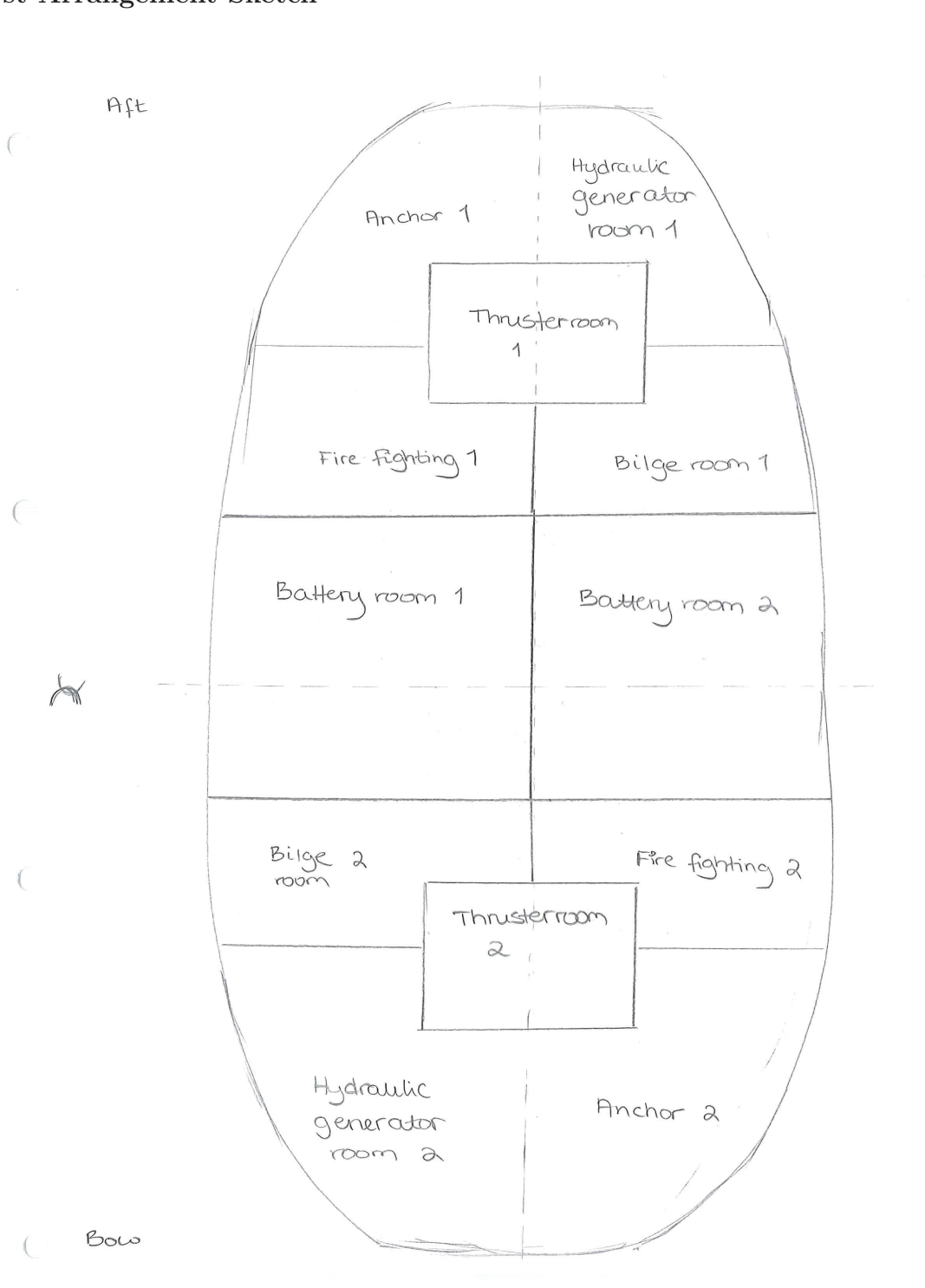

# Cooling System Sketch

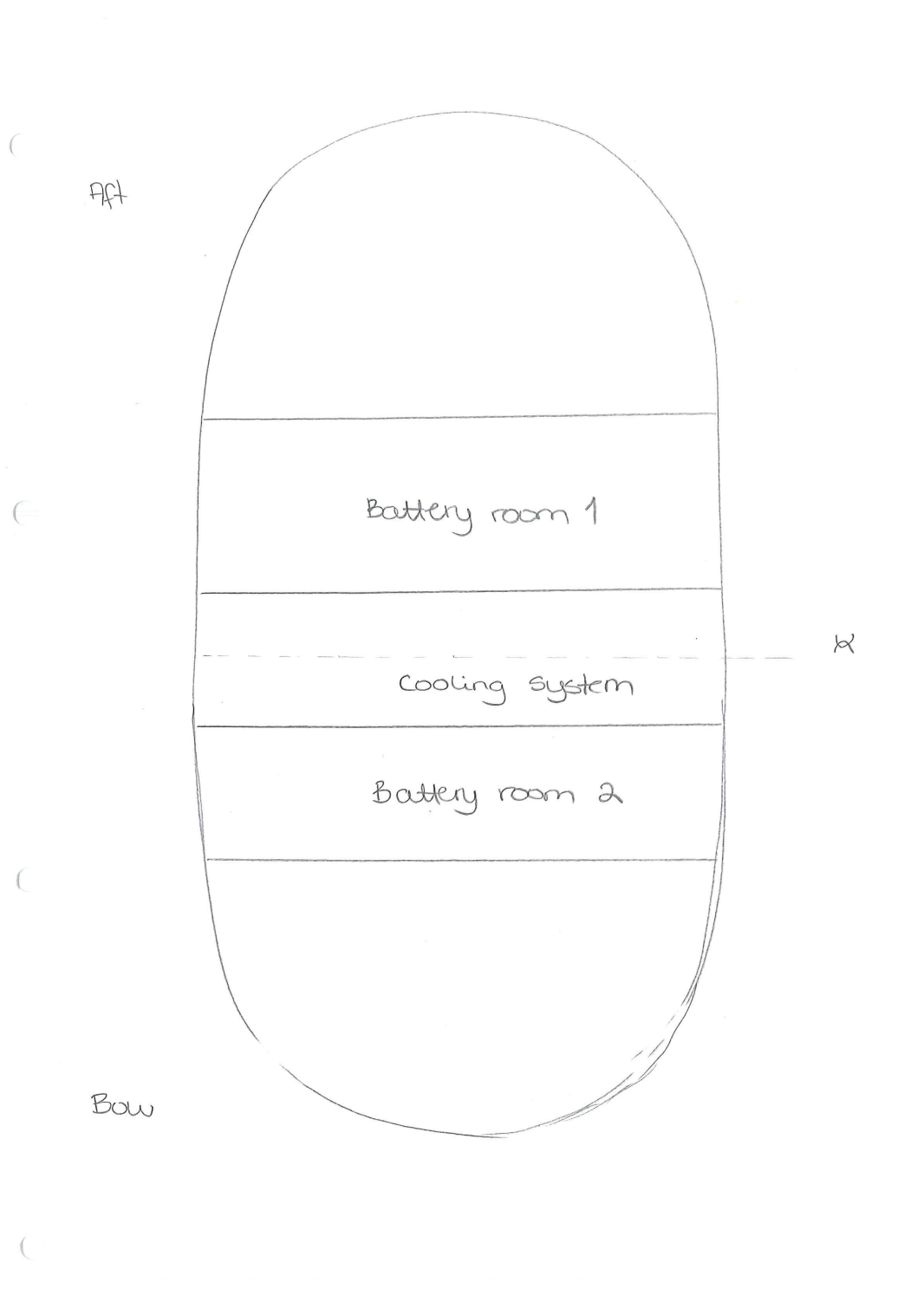

# Final Arrangement Sketch

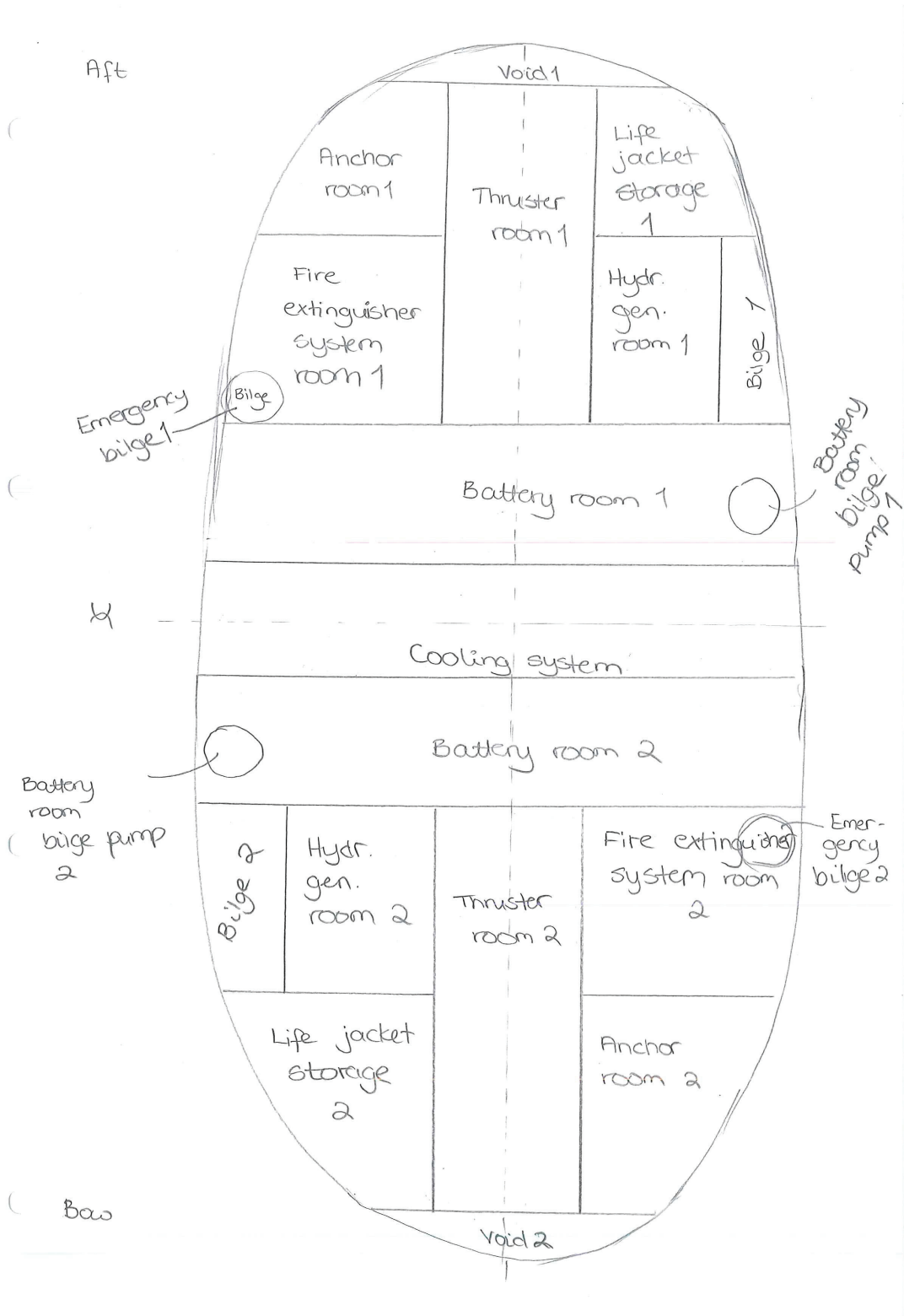

# E Appendix: Validation of design

## E.1 Simplified Strength Requirements

|  | 8          | 15         | 9         |
|--|------------|------------|-----------|
|  | LOA <= 8 m | LOA = 15 m | LOA = 9 m |
|  | max 300    | max 300    | max 300   |
| Frame spacing [mm]                       |            |            |           |
| Running keel (?) [mm]                    | 18         | 24         | 18.9      |
|  | 16         | 20         | 16.6      |
| Centred keel [mm]                        | 18         | 24         | 18.9      |
|  | 6          | 8          | 6.3       |
| Bottom longitudinal girder [mm]          | 200        | 250        | 207.1     |
|  | 5          | 6          | 5.1       |
| Flange on top of bottom long girder [mm] | 5          | 6          | 5.1       |
| Inner keel [mm]                          | 100        | 120        | 102.9     |
| Frame [mm]                               | 90         | 100        | 91.4      |
| Bottom plate [mm]                        | 4.5        | 7          | 4.9       |
| Side plate [mm]                          | 4          | 6          | 4.3       |
| Bulkhead [mm]                            | 4.5        | 6          | 4.7       |
| Bulkhead stiffener [mm]                  | 6          | 8          | 6.3       |
| Deck [mm]                                | 4          | 6          | 4.3       |
| Deck beam [mm]                           | 8          | 8          | 8.0       |
| Bulwark [mm]                             | 4          | 6          | 4.3       |
| Superstructure [mm]                      | 3          | 5          | 3.3       |
| sectional area [cm <sup>2</sup> ]        |            |            |           |
| min thickness                            |            |            |           |
| sectional area [cm <sup>2</sup> ]        |            |            |           |
| min thickness                            |            |            |           |
| Height                                   |            |            |           |
| Thickness                                |            |            |           |
| 50 x                                     |            |            |           |
| UNP                                      |            |            |           |
| 8 x                                      |            |            |           |
| 50 x                                     |            |            |           |
| 90 x                                     |            |            |           |

## E.2 Design Hydrostatics Report without Ballast

Design hydrostatics report

### Design hydrostatics report

|                        |           |                               |            |
|------------------------|-----------|-------------------------------|------------|
| <b>Designer</b>        |           |                               |            |
| <b>Created by</b>      |           |                               |            |
| <b>Comment</b>         |           |                               |            |
| <b>Filename</b>        |           | SkrogmedVekter.fbm            |            |
| <b>Design length</b>   | 9.000 (m) | <b>Midship location</b>       | 4.500 (m)  |
| <b>Length over all</b> | 9.000 (m) | <b>Relative water density</b> | 1.0250     |
| <b>Design beam</b>     | 4.000 (m) | <b>Mean shell thickness</b>   | 0.0000 (m) |
| <b>Maximum beam</b>    | 4.000 (m) | <b>Appendage coefficient</b>  | 1.0000     |
| <b>Design draft</b>    | 0.485 (m) |                               |            |

| Volume properties               |                          | Waterplane properties           |                          |
|---------------------------------|--------------------------|---------------------------------|--------------------------|
| Moulded volume                  | 6.679 (m <sup>3</sup> )  | Length on waterline             | 8.834 (m)                |
| Total displaced volume          | 6.679 (m <sup>3</sup> )  | Beam on waterline               | 3.550 (m)                |
| Displacement                    | 6.846 (tonnes)           | Entrance angle                  | 54.504 (Degr.)           |
| Block coefficient               | 0.4391                   | Waterplane area                 | 24.361 (m <sup>2</sup> ) |
| Prismatic coefficient           | 0.7448                   | Waterplane coefficient          | 0.7767                   |
| Vert. prismatic coefficient     | 0.5653                   | Waterplane center of floatation | 4.000 (m)                |
| Wetted surface area             | 26.335 (m <sup>2</sup> ) | Transverse moment of inertia    | 21.090 (m <sup>4</sup> ) |
| Longitudinal center of buoyancy | 3.995 (m)                | Longitudinal moment of inertia  | 106.62 (m <sup>4</sup> ) |
| Longitudinal center of buoyancy | -5.721 %                 |                                 |                          |
| Vertical center of buoyancy     | 0.316 (m)                |                                 |                          |
| Total length of submerged body  | 8.834 (m)                |                                 |                          |
| Total beam of submerged body    | 3.550 (m)                |                                 |                          |

| Midship properties   |                         | Initial stability               |            |
|----------------------|-------------------------|---------------------------------|------------|
| Midship section area | 1.015 (m <sup>2</sup> ) | Transverse metacentric height   | 3.473 (m)  |
| Midship coefficient  | 0.5895                  | Longitudinal metacentric height | 16.279 (m) |

| Lateral plane                 |                         |
|-------------------------------|-------------------------|
| Lateral area                  | 4.125 (m <sup>2</sup> ) |
| Longitudinal center of effort | 4.000 (m)               |
| Vertical center of effort     | 0.247 (m)               |

The following layer properties are calculated for both sides of the ship

| Location     | Area              | Thickness | Weight       | LCG          | TCG               | VCG          |
|--------------|-------------------|-----------|--------------|--------------|-------------------|--------------|
|              | (m <sup>2</sup> ) | (m)       | (tonnes)     | (m)          | (m)               | (m)          |
| Hull         | 43.725            | 0.005     | 0.590        | 4.000        | 0.000 (CL)        | 0.457        |
| Main deck    | 30.768            | 0.005     | 0.415        | 4.000        | 0.000 (CL)        | 1.200        |
| <b>Total</b> | <b>74.494</b>     |           | <b>1.006</b> | <b>4.000</b> | <b>0.000 (CL)</b> | <b>0.764</b> |

| Sectional areas |                   |          |                   |          |                   |          |                   |          |                   |
|-----------------|-------------------|----------|-------------------|----------|-------------------|----------|-------------------|----------|-------------------|
| Location        | Area              | Location | Area              | Location | Area              | Location | Area              | Location | Area              |
| (m)             | (m <sup>2</sup> ) | (m)      | (m <sup>2</sup> ) | (m)      | (m <sup>2</sup> ) | (m)      | (m <sup>2</sup> ) | (m)      | (m <sup>2</sup> ) |
| 0.000           | 0.220             | 2.400    | 0.990             | 4.800    | 1.013             | 7.200    | 0.565             |          |                   |
| 0.800           | 0.583             | 3.200    | 1.013             | 5.600    | 0.990             | 8.000    | 0.222             |          |                   |
| 1.600           | 0.891             | 4.000    | 1.016             | 6.400    | 0.891             |          |                   |          |                   |

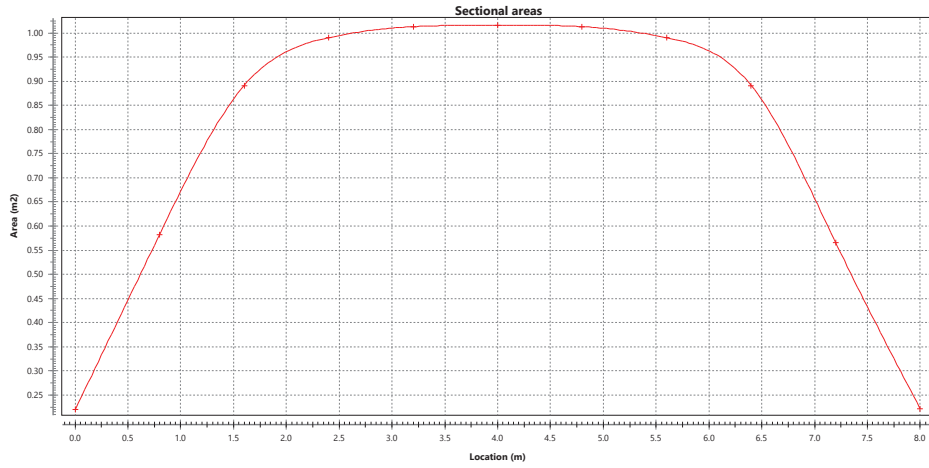

NOTE 1: Draft (and all other vertical heights) is measured from base  $Z=0.000$   
NOTE 2: All calculated coefficients based on actual dimensions of submerged body.



## E.3 Design Hydrostatics Report with 750 kg Ballast

Design hydrostatics report

### Design hydrostatics report

|                        |           |                               |            |
|------------------------|-----------|-------------------------------|------------|
| <b>Designer</b>        |           |                               |            |
| <b>Created by</b>      |           |                               |            |
| <b>Comment</b>         |           |                               |            |
| <b>Filename</b>        |           | SkrogmedVekter075.fbm         |            |
| <b>Design length</b>   | 9.000 (m) | <b>Midship location</b>       | 4.500 (m)  |
| <b>Length over all</b> | 9.000 (m) | <b>Relative water density</b> | 1.0250     |
| <b>Design beam</b>     | 4.000 (m) | <b>Mean shell thickness</b>   | 0.0000 (m) |
| <b>Maximum beam</b>    | 4.000 (m) | <b>Appendage coefficient</b>  | 1.0000     |
| <b>Design draft</b>    | 0.515 (m) |                               |            |

| Volume properties               |                          | Waterplane properties           |                          |
|---------------------------------|--------------------------|---------------------------------|--------------------------|
| Moulded volume                  | 7.421 (m <sup>3</sup> )  | Length on waterline             | 8.852 (m)                |
| Total displaced volume          | 7.421 (m <sup>3</sup> )  | Beam on waterline               | 3.629 (m)                |
| Displacement                    | 7.607 (tonnes)           | Entrance angle                  | 55.631 (Degr.)           |
| Block coefficient               | 0.4486                   | Waterplane area                 | 25.108 (m <sup>2</sup> ) |
| Prismatic coefficient           | 0.7466                   | Waterplane coefficient          | 0.7816                   |
| Vert. prismatic coefficient     | 0.5739                   | Waterplane center of floatation | 4.000 (m)                |
| Wetted surface area             | 27.311 (m <sup>2</sup> ) | Transverse moment of inertia    | 22.849 (m <sup>4</sup> ) |
| Longitudinal center of buoyancy | 3.995 (m)                | Longitudinal moment of inertia  | 111.08 (m <sup>4</sup> ) |
| Longitudinal center of buoyancy | -5.702 %                 |                                 |                          |
| Vertical center of buoyancy     | 0.334 (m)                |                                 |                          |
| Total length of submerged body  | 8.852 (m)                |                                 |                          |
| Total beam of submerged body    | 3.629 (m)                |                                 |                          |

| Midship properties   |                         | Initial stability               |            |
|----------------------|-------------------------|---------------------------------|------------|
| Midship section area | 1.123 (m <sup>2</sup> ) | Transverse metacentric height   | 3.413 (m)  |
| Midship coefficient  | 0.6008                  | Longitudinal metacentric height | 15.302 (m) |

| Lateral plane                 |                         |
|-------------------------------|-------------------------|
| Lateral area                  | 4.390 (m <sup>2</sup> ) |
| Longitudinal center of effort | 4.000 (m)               |
| Vertical center of effort     | 0.262 (m)               |

The following layer properties are calculated for both sides of the ship

| Location     | Area              | Thickness | Weight       | LCG          | TCG               | VCG          |
|--------------|-------------------|-----------|--------------|--------------|-------------------|--------------|
|              | (m <sup>2</sup> ) | (m)       | (tonnes)     | (m)          | (m)               | (m)          |
| Hull         | 43.725            | 0.005     | 0.590        | 4.000        | 0.000 (CL)        | 0.457        |
| Main deck    | 30.768            | 0.005     | 0.415        | 4.000        | 0.000 (CL)        | 1.200        |
| <b>Total</b> | <b>74.494</b>     |           | <b>1.006</b> | <b>4.000</b> | <b>0.000 (CL)</b> | <b>0.764</b> |

| Sectional areas |                   |          |                   |          |                   |          |                   |          |                   |
|-----------------|-------------------|----------|-------------------|----------|-------------------|----------|-------------------|----------|-------------------|
| Location        | Area              | Location | Area              | Location | Area              | Location | Area              | Location | Area              |
| (m)             | (m <sup>2</sup> ) | (m)      | (m <sup>2</sup> ) | (m)      | (m <sup>2</sup> ) | (m)      | (m <sup>2</sup> ) | (m)      | (m <sup>2</sup> ) |
| 0.000           | 0.249             | 2.400    | 1.097             | 4.800    | 1.121             | 7.200    | 0.634             |          |                   |
| 0.800           | 0.652             | 3.200    | 1.121             | 5.600    | 1.097             | 8.000    | 0.251             |          |                   |
| 1.600           | 0.992             | 4.000    | 1.124             | 6.400    | 0.992             |          |                   |          |                   |

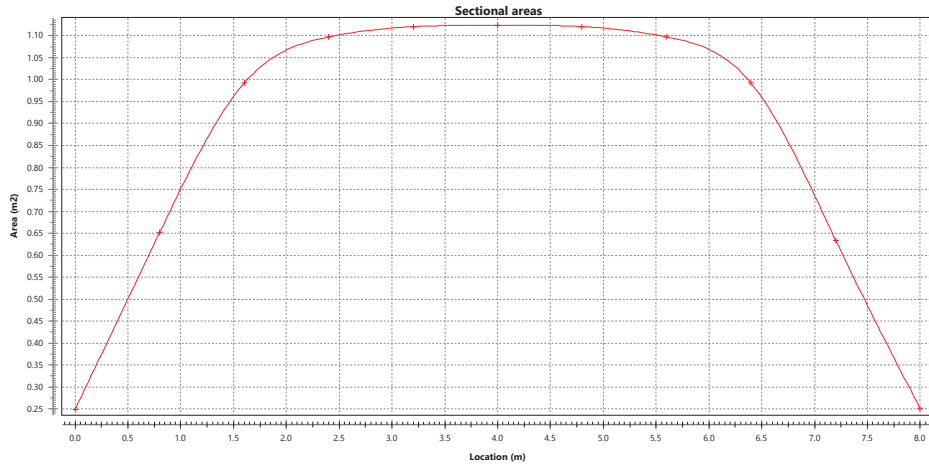

NOTE 1: Draft (and all other vertical heights) is measured from base  $Z=0.000$   
NOTE 2: All calculated coefficients based on actual dimensions of submerged body.

## E.4 Extract from Stability Reports

### Report for Vessel without Ballast

Intact stability

| Summary of intact stability         |         |       |           |       |          |          |       |       |          |
|-------------------------------------|---------|-------|-----------|-------|----------|----------|-------|-------|----------|
| Description                         | Density | Draft | Draft BoK | Trim  | List     | Displ.   | VCG'  | GM'   | Complies |
|                                     |         | (m)   | (m)       | (m)   | (Degr.)  | (tonnes) | (m)   | (m)   |          |
| Empty vessel                        | 1.0250  | 0.414 | 0.414     | 0.004 | 0.0 (CL) | 5.150    | 1.178 | 2.354 | NO       |
| LC1                                 | 1.0250  | 0.461 | 0.461     | 0.003 | 0.0 (CL) | 6.266    | 1.300 | 2.206 | NO       |
| LC2                                 | 1.0250  | 0.471 | 0.471     | 0.003 | 0.0 (CL) | 6.500    | 1.308 | 2.185 | NO       |
| LC3                                 | 1.0250  | 0.459 | 0.459     | 0.003 | 0.0 (CL) | 6.201    | 1.292 | 2.218 | NO       |
| LC4                                 | 1.0250  | 0.460 | 0.460     | 0.003 | 0.0 (CL) | 6.240    | 1.295 | 2.213 | NO       |
| LC5                                 | 1.0250  | 0.453 | 0.453     | 0.003 | 0.0 (CL) | 6.050    | 1.286 | 2.232 | NO       |
| All passengers on starboard side    | 1.0250  | 0.432 | 0.432     | 0.003 | 7.0 (PS) | 6.050    | 1.286 | 2.232 | NO       |
| All passengers in aft               | 1.0250  | 0.449 | 0.449     | 0.250 | 0.0 (CL) | 6.050    | 1.286 | 2.195 | NO       |
| Snow on ferry roof, 50 cm           | 1.0250  | 0.553 | 0.553     | 0.003 | 0.0 (CL) | 8.590    | 2.248 | 1.071 | NO       |
| 5 Wheelchairs in aft half           | 1.0250  | 0.461 | 0.461     | 0.114 | 0.0 (CL) | 6.275    | 1.272 | 2.227 | NO       |
| 3 Wheelchairs in aft half of vessel | 1.0250  | 0.442 | 0.442     | 0.120 | 0.0 (CL) | 5.825    | 1.239 | 2.277 | NO       |
| 3 Wheelchairs on starboard          | 1.0250  | 0.437 | 0.437     | 0.022 | 3.9 (PS) | 5.825    | 1.239 | 2.284 | NO       |
| 30 kg luggage per passenger         | 1.0250  | 0.467 | 0.467     | 0.003 | 0.0 (CL) | 6.410    | 1.292 | 2.205 | NO       |
| Snow on ferry roof, 10 cm           | 1.0250  | 0.444 | 0.444     | 0.003 | 0.0 (CL) | 5.838    | 1.493 | 2.029 | NO       |
| Loading capacity                    | 1.0250  | 0.486 | 0.486     | 0.003 | 0.0 (CL) | 6.860    | 1.312 | 2.160 | NO       |

| Summary of bending moments and shear forces |          |          |          |          |        |          |        |          |  |
|---|----------|----------|----------|----------|--------|----------|--------|----------|--|
| Description                                 | SF min   | X SF min | SF max   | X SF max | BM min | X BM min | BM max | X BM max |  |
|   | (tonnes) | (m)      | (tonnes) | (m)      | (t*m)  | (m)      | (t*m)  | (m)      |  |
| Empty vessel                                | -0.275   | 6.800    | 0.270    | 1.200    | 0.000  | 0.000    | 0.540  | 5.440    |  |
| LC1   | -0.198   | 7.480    | 0.198    | 0.520    | 0.000  | 0.000    | 0.314  | 6.240    |  |
| LC2   | -0.207   | 2.760    | 0.208    | 5.200    | -0.056 | 4.000    | 0.285  | 6.360    |  |
| LC3   | -0.201   | 7.440    | 0.201    | 0.520    | 0.000  | 0.000    | 0.323  | 6.200    |  |
| LC4   | -0.199   | 7.480    | 0.199    | 0.520    | 0.000  | 0.000    | 0.318  | 6.240    |  |
| LC5   | -0.207   | 7.400    | 0.206    | 0.560    | 0.000  | 0.000    | 0.346  | 6.120    |  |
| All passengers on starboard side            | -0.302   | 6.760    | 0.298    | 1.240    | 0.000  | 0.000    | 0.576  | 5.360    |  |
| All passengers in aft                       | -0.677   | 6.500    | 0.420    | 1.360    | 0.000  | 0.000    | 1.281  | 5.200    |  |
| Snow on ferry roof, 50 cm                   | -0.477   | 1.850    | 0.475    | 6.150    | -0.756 | 4.000    | 0.133  | 7.040    |  |
| 5 Wheelchairs in aft half                   | -0.226   | 6.960    | 0.268    | 1.125    | 0.000  | 0.000    | 0.479  | 2.280    |  |
| 3 Wheelchairs in aft half of vessel         | -0.273   | 6.800    | 0.317    | 1.250    | 0.000  | 0.000    | 0.622  | 2.800    |  |
| 3 Wheelchairs on starboard                  | -0.212   | 7.400    | 0.231    | 1.000    | 0.000  | 0.000    | 0.417  | 2.080    |  |
| 30 kg luggage per passenger                 | -0.195   | 2.800    | 0.197    | 5.160    | -0.021 | 4.000    | 0.296  | 6.320    |  |
| Snow on ferry roof, 10 cm                   | -0.216   | 7.360    | 0.215    | 0.600    | 0.000  | 0.000    | 0.384  | 5.920    |  |
| Loading capacity                            | -0.256   | 2.600    | 0.256    | 5.360    | -0.196 | 4.000    | 0.246  | 6.480    |  |

# Report for Vessel with 750 kg Ballast

Intact stability

| Summary of intact stability         |         |       |           |       |          |          |       |       |          |
|-------------------------------------|---------|-------|-----------|-------|----------|----------|-------|-------|----------|
| Description                         | Density | Draft | Draft BoK | Trim  | List     | Displ.   | VCG'  | GM'   | Complies |
|                                     |         | (m)   | (m)       | (m)   | (Degr.)  | (tonnes) | (m)   | (m)   |          |
| Empty vessel                        | 1.0250  | 0.446 | 0.446     | 0.003 | 0.0 (CL) | 5.900    | 1.044 | 2.477 | YES      |
| LC1                                 | 1.0250  | 0.492 | 0.492     | 0.003 | 0.0 (CL) | 7.016    | 1.174 | 2.285 | YES      |
| LC2                                 | 1.0250  | 0.501 | 0.501     | 0.003 | 0.0 (CL) | 7.250    | 1.185 | 2.255 | YES      |
| LC3                                 | 1.0250  | 0.489 | 0.489     | 0.003 | 0.0 (CL) | 6.951    | 1.166 | 2.299 | YES      |
| LC4                                 | 1.0250  | 0.491 | 0.491     | 0.003 | 0.0 (CL) | 6.990    | 1.169 | 2.292 | YES      |
| LC5                                 | 1.0250  | 0.483 | 0.483     | 0.003 | 0.0 (CL) | 6.800    | 1.157 | 2.319 | YES      |
| All passengers on starboard side    | 1.0250  | 0.470 | 0.470     | 0.003 | 5.9 (PS) | 6.800    | 1.157 | 2.319 | NO       |
| All passsengrs in aft               | 1.0250  | 0.480 | 0.480     | 0.236 | 0.0 (CL) | 6.800    | 1.157 | 2.286 | YES      |
| Snow on ferry roof, 50 cm           | 1.0250  | 0.581 | 0.581     | 0.003 | 0.0 (CL) | 9.340    | 2.078 | 1.165 | NO       |
| 5 Wheelchairs in aft half           | 1.0250  | 0.492 | 0.492     | 0.108 | 0.0 (CL) | 7.025    | 1.149 | 2.303 | YES      |
| 3 Wheelchairs in aft halv of vessel | 1.0250  | 0.473 | 0.473     | 0.114 | 0.0 (CL) | 6.575    | 1.112 | 2.370 | YES      |
| 3 Wheelchairs on starboard          | 1.0250  | 0.470 | 0.470     | 0.021 | 3.3 (PS) | 6.575    | 1.112 | 2.377 | NO       |
| 30 kg luggage per passenger         | 1.0250  | 0.497 | 0.497     | 0.003 | 0.0 (CL) | 7.160    | 1.170 | 2.278 | YES      |
| Snow on ferry roof, 10 cm           | 1.0250  | 0.475 | 0.475     | 0.003 | 0.0 (CL) | 6.588    | 1.337 | 2.150 | NO       |
| Loading Capacity                    | 1.0250  | 0.515 | 0.515     | 0.002 | 0.0 (CL) | 7.610    | 1.195 | 2.218 | YES      |

| Summary of bending moments and shear forces |          |          |          |          |        |          |        |          |  |
|---|----------|----------|----------|----------|--------|----------|--------|----------|--|
| Description                                 | SF min   | X SF min | SF max   | X SF max | BM min | X BM min | BM max | X BM max |  |
|   | (tonnes) | (m)      | (tonnes) | (m)      | (t*m)  | (m)      | (t*m)  | (m)      |  |
| Empty vessel                                | -0.313   | 6.800    | 0.307    | 1.240    | 0.000  | 0.000    | 0.611  | 5.320    |  |
| LC1   | -0.221   | 7.360    | 0.220    | 0.600    | 0.000  | 0.000    | 0.359  | 6.160    |  |
| LC2   | -0.210   | 7.400    | 0.210    | 0.560    | 0.000  | 0.000    | 0.325  | 6.240    |  |
| LC3   | -0.224   | 7.360    | 0.223    | 0.640    | 0.000  | 0.000    | 0.369  | 6.120    |  |
| LC4   | -0.222   | 7.360    | 0.221    | 0.600    | 0.000  | 0.000    | 0.363  | 6.120    |  |
| LC5   | -0.233   | 7.040    | 0.230    | 0.640    | 0.000  | 0.000    | 0.394  | 6.040    |  |
| All passengers on starboard side            | -0.334   | 6.750    | 0.328    | 1.250    | 0.000  | 0.000    | 0.636  | 5.280    |  |
| All passsengrs in aft                       | -0.715   | 6.500    | 0.459    | 1.360    | 0.000  | 0.000    | 1.354  | 5.120    |  |
| Snow on ferry roof, 50 cm                   | -0.449   | 1.850    | 0.448    | 6.150    | -0.686 | 4.000    | 0.147  | 6.920    |  |
| 5 Wheelchairs in aft half                   | -0.260   | 6.920    | 0.304    | 1.160    | 0.000  | 0.000    | 0.542  | 2.360    |  |
| 3 Wheelchairs in aft halv of vessel         | -0.309   | 6.800    | 0.354    | 1.250    | 0.000  | 0.000    | 0.700  | 2.920    |  |
| 3 Wheelchairs on starboard                  | -0.238   | 7.000    | 0.264    | 1.040    | 0.000  | 0.000    | 0.470  | 2.160    |  |
| 30 kg luggage per passenger                 | -0.214   | 7.400    | 0.213    | 0.560    | 0.000  | 0.000    | 0.337  | 6.200    |  |
| Snow on ferry roof, 10 cm                   | -0.250   | 7.000    | 0.244    | 1.000    | 0.000  | 0.000    | 0.441  | 5.760    |  |
| Loading Capacity                            | -0.236   | 2.680    | 0.236    | 5.320    | -0.117 | 4.000    | 0.280  | 6.400    |  |

# Report for Vessel without Ballast, New Modified Criteria

Intact stability

| <b>Summary of intact stability</b>  |                |              |                  |             |             |               |             |            |                 |
|-------------------------------------|----------------|--------------|------------------|-------------|-------------|---------------|-------------|------------|-----------------|
| <b>Description</b>                  | <b>Density</b> | <b>Draft</b> | <b>Draft BoK</b> | <b>Trim</b> | <b>List</b> | <b>Displ.</b> | <b>VCG'</b> | <b>GM'</b> | <b>Complies</b> |
|                                     |                | (m)          | (m)              | (m)         | (Degr.)     | (tonnes)      | (m)         | (m)        |                 |
| Empty vessel                        | 1.0250         | 0.413        | 0.413            | 0.004       | 0.0 (CL)    | 5.126         | 1.181       | 2.350      | YES             |
| LC1                                 | 1.0250         | 0.460        | 0.460            | 0.003       | 0.0 (CL)    | 6.242         | 1.303       | 2.205      | YES             |
| LC2                                 | 1.0250         | 0.470        | 0.470            | 0.003       | 0.0 (CL)    | 6.476         | 1.310       | 2.183      | YES             |
| LC3                                 | 1.0250         | 0.458        | 0.458            | 0.003       | 0.0 (CL)    | 6.177         | 1.294       | 2.217      | YES             |
| LC4                                 | 1.0250         | 0.459        | 0.459            | 0.003       | 0.0 (CL)    | 6.216         | 1.297       | 2.212      | YES             |
| LC5                                 | 1.0250         | 0.452        | 0.452            | 0.003       | 0.0 (CL)    | 6.026         | 1.289       | 2.230      | YES             |
| All passengers on starboard side    | 1.0250         | 0.431        | 0.431            | 0.003       | 7.1 (PS)    | 6.026         | 1.289       | 2.230      | NO              |
| All passsengrs in aft               | 1.0250         | 0.448        | 0.448            | 0.250       | 0.0 (CL)    | 6.026         | 1.289       | 2.193      | YES             |
| Snow on ferry roof, 50 cm           | 1.0250         | 0.552        | 0.552            | 0.003       | 0.0 (CL)    | 8.566         | 2.253       | 1.069      | NO              |
| 5 Wheelchairs in aft half           | 1.0250         | 0.460        | 0.460            | 0.114       | 0.0 (CL)    | 6.251         | 1.275       | 2.225      | YES             |
| 3 Wheelchairs in aft halv of vessel | 1.0250         | 0.441        | 0.441            | 0.121       | 0.0 (CL)    | 5.801         | 1.242       | 2.275      | YES             |
| 3 Wheelchairs on starboard          | 1.0250         | 0.435        | 0.435            | 0.022       | 3.9 (PS)    | 5.801         | 1.242       | 2.282      | YES             |
| 30 kg luggage per passenger         | 1.0250         | 0.466        | 0.466            | 0.003       | 0.0 (CL)    | 6.386         | 1.295       | 2.204      | YES             |
| Snow on ferry roof, 10 cm           | 1.0250         | 0.443        | 0.443            | 0.003       | 0.0 (CL)    | 5.814         | 1.497       | 2.026      | YES             |
| Loading capacity                    | 1.0250         | 0.485        | 0.485            | 0.003       | 0.0 (CL)    | 6.836         | 1.315       | 2.159      | YES             |

| <b>Summary of bending moments and shear forces</b> |               |                 |               |                 |               |                 |               |                 |  |
|--|---------------|-----------------|---------------|-----------------|---------------|-----------------|---------------|-----------------|--|
| <b>Description</b>                                 | <b>SF min</b> | <b>X SF min</b> | <b>SF max</b> | <b>X SF max</b> | <b>BM min</b> | <b>X BM min</b> | <b>BM max</b> | <b>X BM max</b> |  |
|  | (tonnes)      | (m)             | (tonnes)      | (m)             | (t*m)         | (m)             | (t*m)         | (m)             |  |
| Empty vessel                                       | -0.274        | 6.840           | 0.268         | 1.200           | 0.000         | 0.000           | 0.531         | 5.520           |  |
| LC1  | -0.199        | 7.480           | 0.199         | 0.520           | 0.000         | 0.000           | 0.313         | 6.240           |  |
| LC2  | -0.221        | 2.760           | 0.222         | 5.240           | -0.066        | 3.920           | 0.284         | 6.360           |  |
| LC3  | -0.202        | 7.440           | 0.201         | 0.520           | 0.000         | 0.000           | 0.322         | 6.240           |  |
| LC4  | -0.200        | 7.440           | 0.200         | 0.520           | 0.000         | 0.000           | 0.317         | 6.240           |  |
| LC5  | -0.208        | 7.400           | 0.207         | 0.560           | 0.000         | 0.000           | 0.344         | 6.160           |  |
| All passengers on starboard side                   | -0.301        | 6.800           | 0.296         | 1.240           | 0.000         | 0.000           | 0.567         | 5.440           |  |
| All passsengrs in aft                              | -0.673        | 6.500           | 0.417         | 1.360           | 0.000         | 0.000           | 1.268         | 5.240           |  |
| Snow on ferry roof, 50 cm                          | -0.482        | 1.850           | 0.481         | 6.150           | -0.766        | 3.951           | 0.134         | 7.040           |  |
| 5 Wheelchairs in aft half                          | -0.228        | 3.200           | 0.268         | 1.120           | 0.000         | 0.000           | 0.474         | 2.240           |  |
| 3 Wheelchairs in aft halv of vessel                | -0.271        | 6.840           | 0.315         | 1.250           | 0.000         | 0.000           | 0.610         | 2.720           |  |
| 3 Wheelchairs on starboard                         | -0.213        | 7.360           | 0.231         | 1.000           | 0.000         | 0.000           | 0.414         | 2.080           |  |
| 30 kg luggage per passenger                        | -0.209        | 2.760           | 0.210         | 5.200           | -0.031        | 3.920           | 0.295         | 6.320           |  |
| Snow on ferry roof, 10 cm                          | -0.217        | 7.360           | 0.216         | 0.600           | 0.000         | 0.000           | 0.381         | 5.920           |  |
| Loading capacity                                   | -0.270        | 2.600           | 0.270         | 5.360           | -0.206        | 3.920           | 0.246         | 6.500           |  |

## Report for Vessel with 750 kg Ballast, New Modified Criteria

Intact stability

| <b>Summary of intact stability</b>  |                |              |                  |             |             |               |             |            |                 |
|-------------------------------------|----------------|--------------|------------------|-------------|-------------|---------------|-------------|------------|-----------------|
| <b>Description</b>                  | <b>Density</b> | <b>Draft</b> | <b>Draft BoK</b> | <b>Trim</b> | <b>List</b> | <b>Displ.</b> | <b>VCG'</b> | <b>GM'</b> | <b>Complies</b> |
|                                     |                | (m)          | (m)              | (m)         | (Degr.)     | (tonnes)      | (m)         | (m)        |                 |
| Empty vessel                        | 1.0250         | 0.445        | 0.445            | 0.003       | 0.0 (CL)    | 5.876         | 1.045       | 2.476      | YES             |
| LC1                                 | 1.0250         | 0.491        | 0.491            | 0.003       | 0.0 (CL)    | 6.992         | 1.175       | 2.286      | YES             |
| LC2                                 | 1.0250         | 0.500        | 0.500            | 0.003       | 0.0 (CL)    | 7.226         | 1.186       | 2.256      | YES             |
| LC3                                 | 1.0250         | 0.488        | 0.488            | 0.003       | 0.0 (CL)    | 6.927         | 1.167       | 2.300      | YES             |
| LC4                                 | 1.0250         | 0.490        | 0.490            | 0.003       | 0.0 (CL)    | 6.966         | 1.170       | 2.293      | YES             |
| LC5                                 | 1.0250         | 0.482        | 0.482            | 0.003       | 0.0 (CL)    | 6.776         | 1.159       | 2.319      | YES             |
| All passengers on starboard side    | 1.0250         | 0.469        | 0.469            | 0.003       | 5.9 (PS)    | 6.776         | 1.159       | 2.319      | YES             |
| All passengers in aft               | 1.0250         | 0.479        | 0.479            | 0.236       | 0.0 (CL)    | 6.776         | 1.159       | 2.286      | YES             |
| Snow on ferry roof, 50 cm           | 1.0250         | 0.580        | 0.580            | 0.003       | 0.0 (CL)    | 9.316         | 2.081       | 1.165      | NO              |
| 5 Wheelchairs in aft half           | 1.0250         | 0.491        | 0.491            | 0.108       | 0.0 (CL)    | 7.001         | 1.150       | 2.304      | YES             |
| 3 Wheelchairs in aft half of vessel | 1.0250         | 0.472        | 0.472            | 0.114       | 0.0 (CL)    | 6.551         | 1.113       | 2.370      | YES             |
| 3 Wheelchairs on starboard          | 1.0250         | 0.469        | 0.469            | 0.021       | 3.3 (PS)    | 6.551         | 1.113       | 2.377      | YES             |
| 30 kg luggage per passenger         | 1.0250         | 0.497        | 0.497            | 0.003       | 0.0 (CL)    | 7.136         | 1.171       | 2.278      | YES             |
| Snow on ferry roof, 10 cm           | 1.0250         | 0.474        | 0.474            | 0.003       | 0.0 (CL)    | 6.564         | 1.339       | 2.149      | YES             |
| Loading Capacity                    | 1.0250         | 0.514        | 0.514            | 0.002       | 0.0 (CL)    | 7.586         | 1.196       | 2.219      | YES             |

| <b>Summary of bending moments and shear forces</b> |               |                 |               |                 |               |                 |               |                 |  |
|--|---------------|-----------------|---------------|-----------------|---------------|-----------------|---------------|-----------------|--|
| <b>Description</b>                                 | <b>SF min</b> | <b>X SF min</b> | <b>SF max</b> | <b>X SF max</b> | <b>BM min</b> | <b>X BM min</b> | <b>BM max</b> | <b>X BM max</b> |  |
|  | (tonnes)      | (m)             | (tonnes)      | (m)             | (t*m)         | (m)             | (t*m)         | (m)             |  |
| Empty vessel                                       | -0.311        | 6.800           | 0.306         | 1.200           | 0.000         | 0.000           | 0.604         | 5.360           |  |
| LC1  | -0.222        | 7.360           | 0.221         | 0.600           | 0.000         | 0.000           | 0.357         | 6.160           |  |
| LC2  | -0.211        | 7.400           | 0.211         | 0.560           | 0.000         | 0.000           | 0.324         | 6.280           |  |
| LC3  | -0.225        | 7.320           | 0.224         | 0.640           | 0.000         | 0.000           | 0.367         | 6.120           |  |
| LC4  | -0.223        | 7.360           | 0.222         | 0.600           | 0.000         | 0.000           | 0.361         | 6.160           |  |
| LC5  | -0.233        | 7.040           | 0.231         | 0.680           | 0.000         | 0.000           | 0.392         | 6.040           |  |
| All passengers on starboard side                   | -0.332        | 6.760           | 0.327         | 1.240           | 0.000         | 0.000           | 0.629         | 5.280           |  |
| All passengers in aft                              | -0.712        | 6.500           | 0.456         | 1.360           | 0.000         | 0.000           | 1.346         | 5.160           |  |
| Snow on ferry roof, 50 cm                          | -0.455        | 1.850           | 0.453         | 6.150           | -0.696        | 4.000           | 0.148         | 6.920           |  |
| 5 Wheelchairs in aft half                          | -0.260        | 6.920           | 0.303         | 1.125           | 0.000         | 0.000           | 0.537         | 2.320           |  |
| 3 Wheelchairs in aft half of vessel                | -0.308        | 6.800           | 0.353         | 1.250           | 0.000         | 0.000           | 0.692         | 2.880           |  |
| 3 Wheelchairs on starboard                         | -0.239        | 7.040           | 0.264         | 1.040           | 0.000         | 0.000           | 0.467         | 2.160           |  |
| 30 kg luggage per passenger                        | -0.215        | 7.400           | 0.214         | 0.600           | 0.000         | 0.000           | 0.336         | 6.240           |  |
| Snow on ferry roof, 10 cm                          | -0.250        | 7.000           | 0.244         | 0.960           | 0.000         | 0.000           | 0.437         | 5.800           |  |
| Loading Capacity                                   | -0.241        | 2.680           | 0.240         | 5.320           | -0.127        | 4.000           | 0.280         | 6.400           |  |

## E.5 Moment curves

Hogging moment

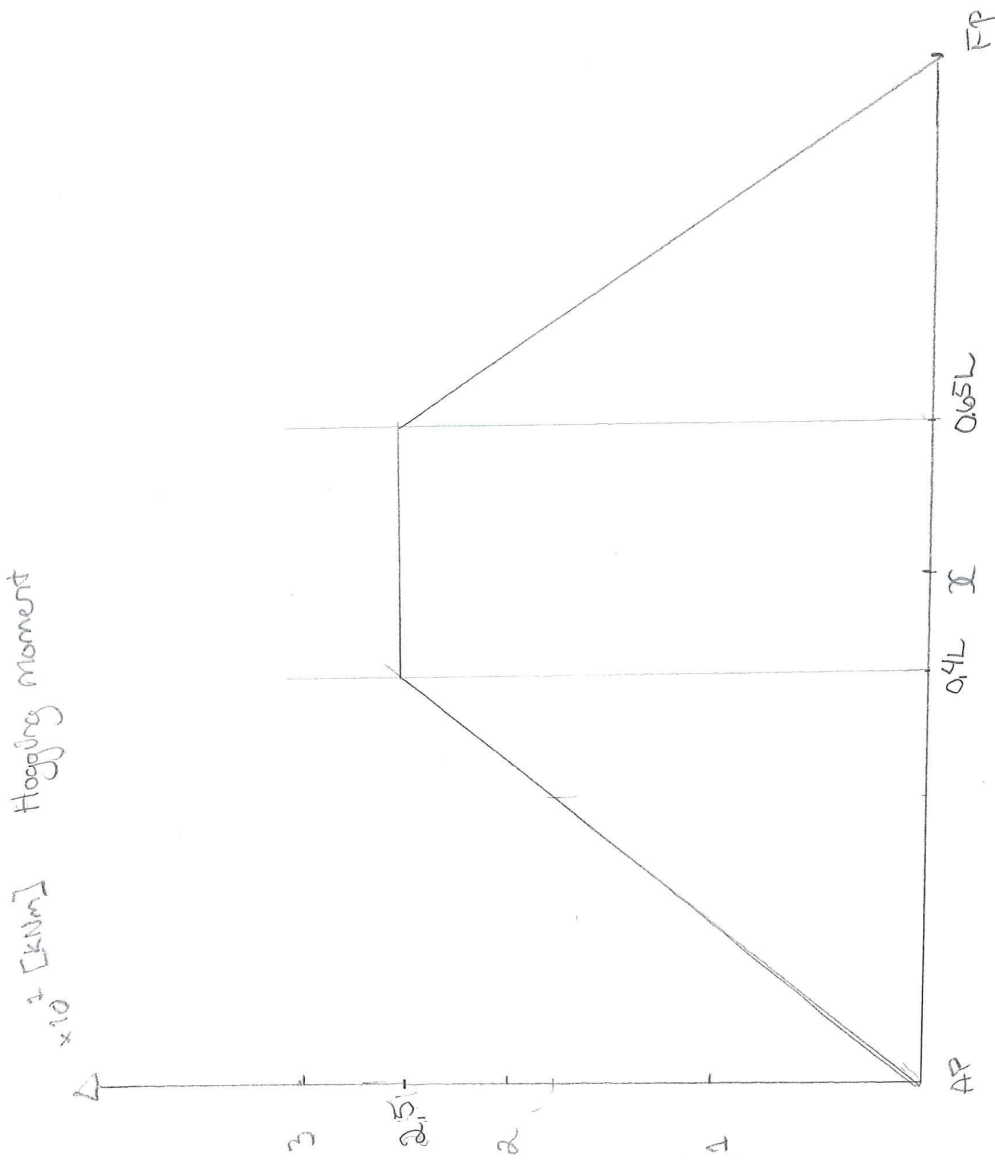

# Sagging moment

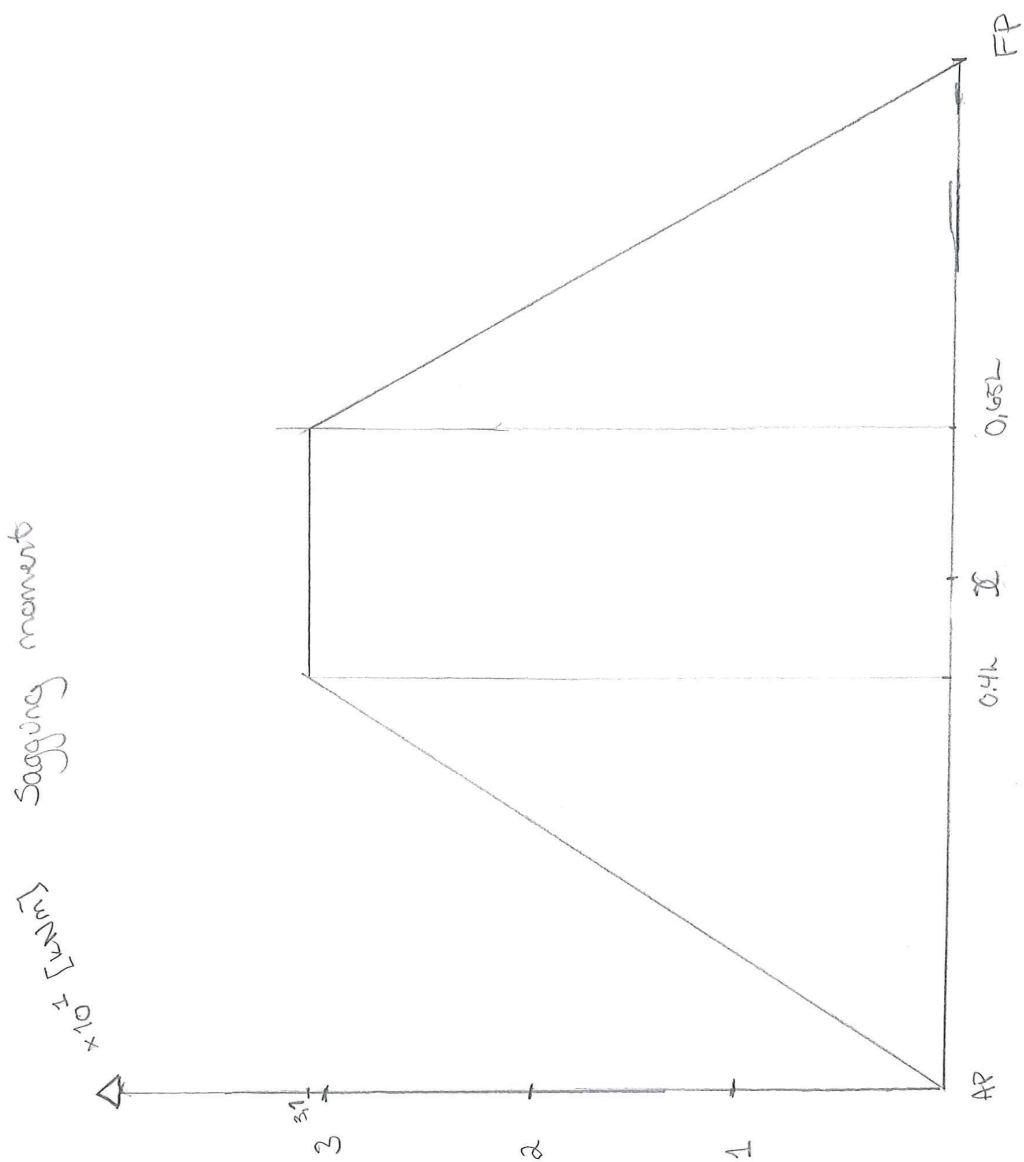



Stillwater moment

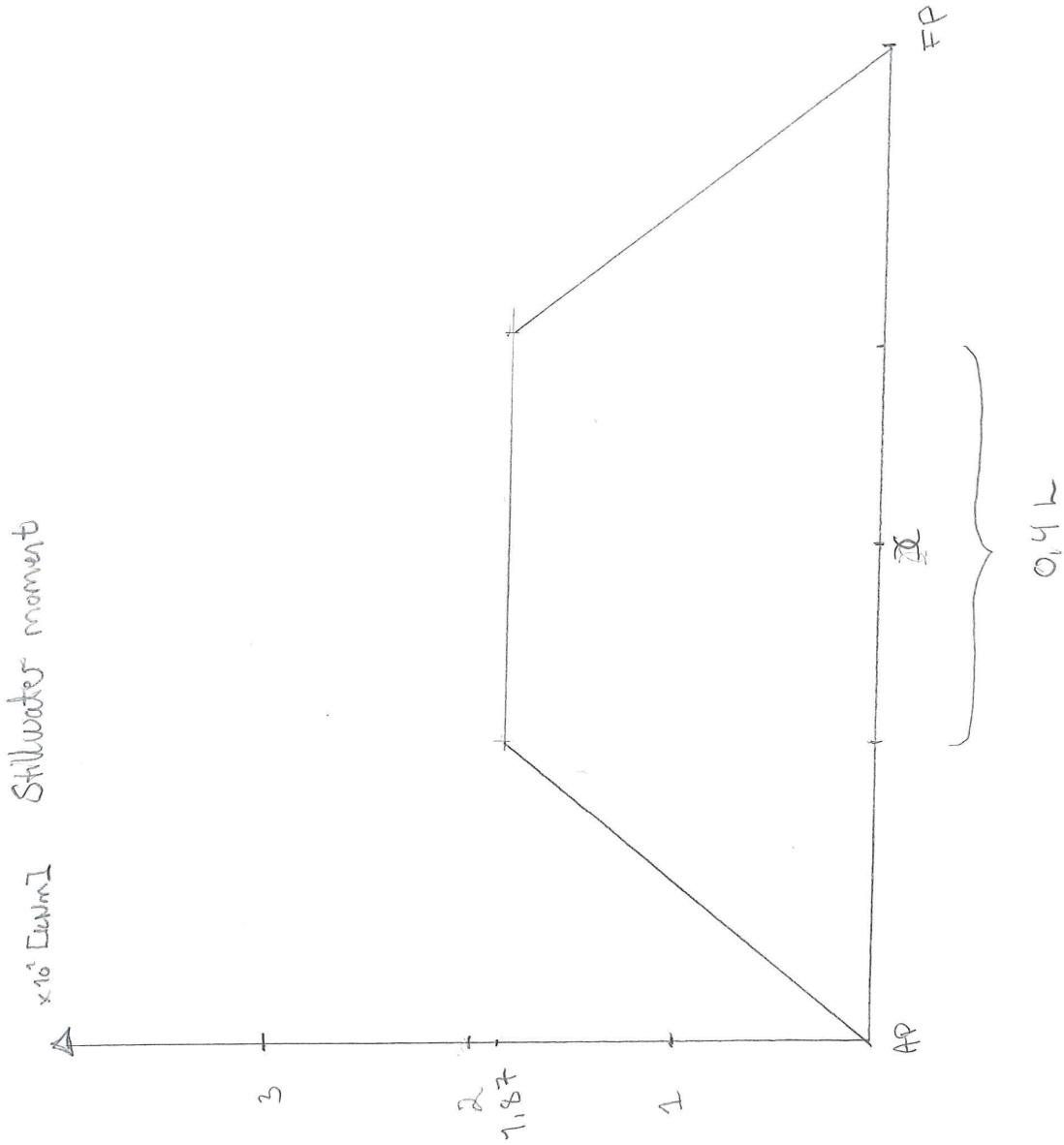

## E.6 Strength Calculations

| NUM. | ELEMENT NAME               | NUM.<br>OF PIECES | BREADTH<br>b<br>mm | HEIGHT<br>h<br>mm | UNIT<br>AREA<br>A <sub>i</sub><br>mm <sup>2</sup> | TOTAL<br>AREA<br>A<br>mm <sup>2</sup> | UNIT CENTROID<br>COORDINATE<br>Y <sub>i</sub><br>mm | FIRST<br>MOM. OF AREA<br>S <sub>x</sub><br>mm <sup>3</sup> | TOTAL CENTROID<br>COORDINATE OF C.S.<br>Σ S <sub>x</sub> / Σ A<br>mm | POSITIONAL MOM. OF INER.<br>COORDINATE<br>Y <sub>i</sub> '<br>mm |
|------|----------------------------|-------------------|--------------------|-------------------|---|---------------------------------------|---|--|--|--|
| 1    | 2                          | 3                 | 4                  | 5                 | 6=4x5   | 7=6x3                                 | 8   | 9=7x8  | 10   | 11=10-8  |
| 1    | Deck Beam Web              | 5                 | 8.00               | 82                | 656   | 3280                                  | 1150  | 3772000  | 621.14   | -528.86  |
| 1    | Deck Beam Flange           | 5                 | 90.00              | 8                 | 720   | 3600                                  | 1101  | 3963600  | 621.14   | -479.86  |
| 2    | Longitudinal Girder Web    | 1                 | 10.00              | 200               | 2000  | 2000                                  | 100   | 200000   | 621.14   | 521.14   |
| 2    | Longitudinal Girder Flange | 1                 | 210.00             | 10                | 2100  | 2100                                  | 205   | 430500   | 621.14   | 416.14   |
| 3    | Plate Bottom               | 2                 | 2030.00            | 5                 | 10150   | 20300                                 | 316   | 6414800  | 621.14   | 305.14   |
| 4    | Plate Side                 | 2                 | 5.00               | 540               | 2700  | 5400                                  | 930   | 5022000  | 621.14   | -308.86  |
| 5    | Plate Deck                 | 1                 | 4000.00            | 5                 | 20000   | 20000                                 | 1197.5  | 23950000   | 621.14   | -576.36  |
| 6    | Spant bottom               | 2                 | 2030.00            | 90                | 182700  | 365400                                | 356   | 130082400  | 621.14   | 265.14   |
| 7    | Spant side                 | 2                 | 90.00              | 540               | 48600   | 97200                                 | 930   | 90396000   | 621.14   | -308.86  |
| 8    | Knee plate bottom          | 1                 | 115.00             | 80                | 9200  | 9200                                  | 142.5   | 1311000  | 621.14   | 478.64   |
| 9    | Knee plate top             | 2                 | 568.00             | 106               | 60208   | 120416                                | 1142  | 137515072  | 621.14   | -520.86  |
|      |                            |                   |                    |                   | Σ A =   | 648896                                | Σ S <sub>x</sub> =                                  | 403057372  |  |  |

| OWN MOM.<br>OF INERTIA              | POSITIONAL MOM.<br>OF INERTIA    | UNIT MOM.<br>OF INERTIA  | TOTAL MOM.<br>OF INERTIA OF C.S. |
|-------------------------------------|----------------------------------|--------------------------|----------------------------------|
| $I_{x_{VL}}$<br>mm <sup>4</sup>     | $I_{x_{POS}}$<br>mm <sup>4</sup> | $I_x$<br>mm <sup>4</sup> | $I_{x'}$<br>mm <sup>4</sup>      |
| 12=4x5 <sup>7</sup> /12             | 13=6x11 <sup>2</sup>             | 14=12+13                 | 15=14x3                          |
| 367578.67                           | 183476285.32                     | 183843863.99             | 919219319.95                     |
| 3840.00                             | 165788998.62                     | 165792838.62             | 828964193.10                     |
| 6666666.67                          | 543180579.34                     | 549847246.00             | 549847246.00                     |
| 17500.00                            | 363667933.93                     | 363685433.93             | 363685433.93                     |
| 21145.83                            | 945090906.39                     | 945112052.22             | 1890224104.45                    |
| 65610000.00                         | 257559724.22                     | 323169724.22             | 646339448.44                     |
| 41666.67                            | 6643742006.86                    | 6643783673.53            | 6643783673.53                    |
| 123322500.00                        | 12843982535.91                   | 12967305035.91           | 25934610071.82                   |
| 1180980000.00                       | 4636075035.96                    | 5817055035.96            | 11634110071.91                   |
| 4906666.67                          | 2107714141.46                    | 2112620808.12            | 2112620808.12                    |
| 56374757.33                         | 16333933766.78                   | 16390308524.11           | 32780617048.23                   |
| <b><math>\Sigma I_{x'}</math> =</b> |                                  |                          | <b>84304021419.48</b>            |

|                    |              |                 |
|--------------------|--------------|-----------------|
| Z=                 | 135723959.13 | mm <sup>3</sup> |
| Z=                 | 135723.96    | cm <sup>3</sup> |
| M=                 | 0.69         | t*m             |
| M=                 | 6729.66      | Nm              |
| M=                 | 6729660.00   | Nmm             |
| Z DNV =            | 2795.10      | cm <sup>3</sup> |
| Sigma =            | 0.05         | Mpa             |
| Flytspenning =     | 170.00       | MPa             |
| Krav tilfredsstilt | OK           |                 |

## E.7 Strength Calculations in Matlab

```
clc
clear
%----- Variables -----%

V = 4; %maximum service speed in knots
L = 9; %length of the ship in m between AP and FP
T = 0.5; % m draught
B = 3.792; %greatest moulded breadth at WL in m from
Delftship
Cb = 0.6; %Usually not smaller than

% SECTION MODULUS FOR AMIDSHIP

Cw = 0.0792*L;
Ms= 0.0052*L^3*B*(Cb+0.7); %kNm (Amid ship)
Mw_sagging = 0.11*Cw*L^2*B*(Cb+0.7); %kNm
Mw_hogging = 0.19*Cw*L^2*B*Cb;%kNm
Z_sagging= (sqrt((Ms+Mw_sagging)^2)/175)*10^3 ; %cm^3
Z_hogging= (sqrt((Ms+Mw_hogging)^2)/175)*10^3 ; %cm^3
Cwo = 7 ; %5.7+0.022*L, or minimum 7
Zo= Cwo*L^2*B*(Cb+0.7) ; %cm^3 , not less than
Z=[Z_sagging,Z_hogging,Zo];
Z_req = max(Z);
fprintf('Stillwater moment amidship [kNm] = %d \n',Ms);
fprintf('Wave load moment sagging, amidship [kNm]= %d
\n',Mw_sagging);
fprintf('Wave load moment hogging, amidship [kNm] = %d
\n',Mw_hogging);
fprintf('Section modulus for amidship [cm^3] = %d
\n',Z_req);
```

## E.8 Results from ShipX

|                            |        |            |
|----------------------------|--------|------------|
| <b>PRINCIPAL HULL DATA</b> | ENCL.  | 1)         |
|                            | REPORT |            |
|                            | DATE   | 2017-06-10 |
|                            | REF    |            |

**SHIP:** **Endeligfergemotstandsberegninger\_28.dwg test4.dxf**  
**(imported)**

Loading condition: Design WL  
 Draught AP/FP: 0.515 / 0.515 [m]

|  | Symbol          | Unit                 |         |
|--|-----------------|----------------------|---------|
| Length overall                             | L <sub>OA</sub> | [m]                  | 9.000   |
| Length on designed waterline               | L <sub>WL</sub> | [m]                  | 8.852   |
| Length betw. perp.                         | L <sub>PP</sub> | [m]                  | 9.000   |
| Breadth moulded                            | B               | [m]                  | 3.629   |
| Breadth waterline                          | B <sub>WL</sub> | [m]                  | 3.629   |
| Depth to 1 <sup>st</sup> deck              | D               | [m]                  | 1.200   |
| Draught at L <sub>PP</sub> /2              | T               | [m]                  | 0.515   |
| Draught at FP                              | T <sub>FP</sub> | [m]                  | 0.515   |
| Draught at AP                              | T <sub>AP</sub> | [m]                  | 0.515   |
| Trim (pos. aft)                            | t               | [m]                  | 0.000   |
| Rake of keel                               |                 | [m]                  | 0.000   |
| Rise of floor                              |                 | [m]                  | 0.000   |
| Bilge radius                               |                 | [m]                  | 0.000   |
| Sea water density                          | □ <sub>s</sub>  | [kg/m <sup>3</sup> ] | 1025.00 |
| Shell plating thickness                    |                 | [mm]                 | 2       |
| Shell plating in % of displ.               |                 | [%]                  | 0.40    |
| Volume displacement                        | □               | [m <sup>3</sup> ]    | 7.5     |
| Displacement                               | □               | [t]                  | 7.7     |
| Prismatic coefficient*                     | C <sub>P</sub>  | [-]                  | 0.7352  |
| Block coefficient*                         | C <sub>B</sub>  | [-]                  | 0.4449  |
| Midship section coefficient                | C <sub>M</sub>  | [-]                  | 0.6052  |
| Longitudinal C.B. from L <sub>PP</sub> /2  | LCB             | [m]                  | -0.505  |
| Longitudinal C.B. from L <sub>PP</sub> /2* | LCB             | [% L <sub>PP</sub> ] | -5.607  |
| Longitudinal C.B. from AP                  | LCB             | [m]                  | 3.995   |
| Wetted surface                             | S               | [m <sup>2</sup> ]    | 27.53   |
| Wetted surface of transom stern            | A <sub>T</sub>  | [m <sup>2</sup> ]    | 0.00    |

**Remarks:** \*Refers to L<sub>PP</sub>  
 Hydrostatic corrections not included

ShipX (RepGen version 2.0.22) 30-May-2017 22:39:24 - Licensed to: NTNU (NTNU)

|                     |        |            |
|---------------------|--------|------------|
| <b>HYDROSTATICS</b> | ENCL.  | 2)         |
|                     | REPORT |            |
|                     | DATE   | 2017-06-10 |
|                     | REF    |            |

**SHIP:**  
**(imported)**

**Endeligfergemotstandsberengninger\_28.dwg test4.dxf**

Loading condition:  
Draught AP/FP:

Design WL  
0.515 / 0.515 [m]

|  | Symbol                            | Unit                 |         |
|--|-----------------------------------|----------------------|---------|
| Length overall                             | L <sub>OA</sub>                   | [m]                  | 9.000   |
| Length betw. perp.                         | L <sub>PP</sub>                   | [m]                  | 9.000   |
| Breadth moulded                            | B                                 | [m]                  | 3.629   |
| Depth to 1 <sup>st</sup> deck              | D                                 | [m]                  | 1.200   |
| Draught at L <sub>PP</sub> /2              | T                                 | [m]                  | 0.515   |
| Draught at FP                              | T <sub>FP</sub>                   | [m]                  | 0.515   |
| Draught at AP                              | T <sub>AP</sub>                   | [m]                  | 0.515   |
| Trim (pos. aft)                            | t                                 | [m]                  | 0.000   |
| Rake of keel                               |                                   | [m]                  | 0.000   |
| Rise of floor                              |                                   | [m]                  | 0.000   |
| Bilge radius                               |                                   | [m]                  | 0.000   |
| Sea water density                          | □ <sub>s</sub>                    | [kg/m <sup>3</sup> ] | 1025.00 |
| Shell plating thickness                    |                                   | [mm]                 | 2       |
| Shell plating in % of displ.               |                                   | [%]                  | 0.40    |
| Length on waterline                        | L <sub>WL</sub>                   | [m]                  | 8.852   |
| Breadth waterline                          | B <sub>WL</sub>                   | [m]                  | 3.629   |
| Volume displacement                        | □                                 | [m <sup>3</sup> ]    | 7.5     |
| Displacement                               | □                                 | [t]                  | 7.7     |
| Prismatic coefficient*                     | C <sub>P</sub>                    | [-]                  | 0.7352  |
| Block coefficient*                         | C <sub>B</sub>                    | [-]                  | 0.4449  |
| Midship section coefficient                | C <sub>M</sub>                    | [-]                  | 0.6052  |
| Longitudinal C.B. from L <sub>PP</sub> /2  | LCB                               | [m]                  | -0.505  |
| Longitudinal C.B. from L <sub>PP</sub> /2* | LCB                               | [% L <sub>PP</sub> ] | -5.607  |
| Longitudinal C.B. from AP                  | LCB                               | [m]                  | 3.995   |
| Vertical C.B.                              | VCB                               | [m]                  | 0.333   |
| Wetted surface                             | S                                 | [m <sup>2</sup> ]    | 27.53   |
| Wetted surface of transom stern            | A <sub>T</sub>                    | [m <sup>2</sup> ]    | 0.00    |
| Waterplane area                            | A <sub>W</sub>                    | [m <sup>2</sup> ]    | 25.17   |
| Waterplane area coefficient                | C <sub>W</sub> (L <sub>WL</sub> ) | [-]                  | 0.783   |
| Longitudinal C.F. from L <sub>PP</sub> /2  | LCF                               | [m]                  | -0.499  |
| Longitudinal C.F. from AP                  | LCF                               | [m]                  | 4.001   |
| Immersion                                  | DP <sub>1</sub>                   | [t/cm]               | 0.258   |
| Trim moment                                | MT <sub>1</sub>                   | [t·m/cm]             | 0.127   |
| Transverse metacenter above keel           | KM <sub>T</sub>                   | [m]                  | 3.408   |
| Longitudinal metacenter above keel         | KM <sub>L</sub>                   | [m]                  | 14.870  |

Remarks: \*Refers to L<sub>PP</sub>  
Hydrostatic corrections not included

ShipX (RepGen version 2.0.22) 30-May-2017 22:39:49 - Licensed to: NTNU (NTNU)

|                                |        |            |
|--------------------------------|--------|------------|
| <b>RESISTANCE COEFFICIENTS</b> | ENCL.  | 3)         |
|                                | REPORT |            |
|                                | DATE   | 2017-06-10 |
|                                | REF    |            |

**Endeligfergemotstandsberengninger\_28.dwg test4.dxf (imported)**  
**Design waterline**  
**Untitled**

SHIP DATA

---

|                                    |       |                |
|------------------------------------|-------|----------------|
| Length between perpendiculars..... | 9.00  | m              |
| Length on waterline.....           | 8.85  | m              |
| Breadth moulded.....               | 3.63  | m              |
| Mean draught.....                  | 0.51  | m              |
| Trim.....                          | 0.00  | m              |
| Wetted surface of naked hull.....  | 27.53 | m <sup>2</sup> |
| Volume displacement.....           | 7.48  | m <sup>3</sup> |

---



---

|                                  |       |    |
|----------------------------------|-------|----|
| Seawater temperature.....        | 15.00 | °C |
| Form factor (calculated).....1+k | 1.565 |    |
| Form factor (user input).....1+k | 1.132 |    |

---



---

| V <sub>S</sub><br>kts | F <sub>N</sub> | C <sub>W</sub><br>·10 <sup>3</sup> | C <sub>RC</sub><br>·10 <sup>3</sup> | C <sub>RU</sub><br>·10 <sup>3</sup> | F <sub>ds</sub><br>·10 <sup>3</sup> | C <sub>F</sub><br>·10 <sup>3</sup> |
|-----------------------|----------------|------------------------------------|-------------------------------------|-------------------------------------|-------------------------------------|------------------------------------|
| 2.92                  | 0.161          | 6.559                              | 6.587                               | 6.579                               | 6.241                               | 2.921                              |
| 3.29                  | 0.181          | 8.406                              | 8.442                               | 8.432                               | 7.992                               | 2.863                              |
| 3.65                  | 0.202          | 9.006                              | 9.049                               | 9.037                               | 9.751                               | 2.813                              |
| 4.02                  | 0.222          | 10.647                             | 10.698                              | 10.684                              | 11.884                              | 2.768                              |
| 4.38                  | 0.242          | 13.354                             | 13.414                              | 13.397                              | 14.123                              | 2.728                              |
| 4.75                  | 0.262          | 14.670                             | 14.743                              | 14.723                              | 17.256                              | 2.692                              |
| 5.11                  | 0.282          | 14.984                             | 15.065                              | 15.042                              | 19.359                              | 2.660                              |
| 5.48                  | 0.303          | 16.017                             | 16.112                              | 16.086                              | 22.960                              | 2.630                              |
| 5.85                  | 0.323          | 19.031                             | 19.140                              | 19.110                              | 26.622                              | 2.603                              |
| 6.21                  | 0.343          | 20.282                             | 20.397                              | 20.365                              | 28.451                              | 2.577                              |

---



|   |        |            |
|---|--------|------------|
| <h1>SHIP RESISTANCE<br/>COEFFICIENTS</h1> | ENCL.  | 4)         |
|   | REPORT |            |
|   | DATE   | 2017-06-10 |
|   | REF    |            |

**Endeligfergemotstandsberegninger\_28.dwg test4.dxf (imported)**  
**Design waterline**  
**Untitled**

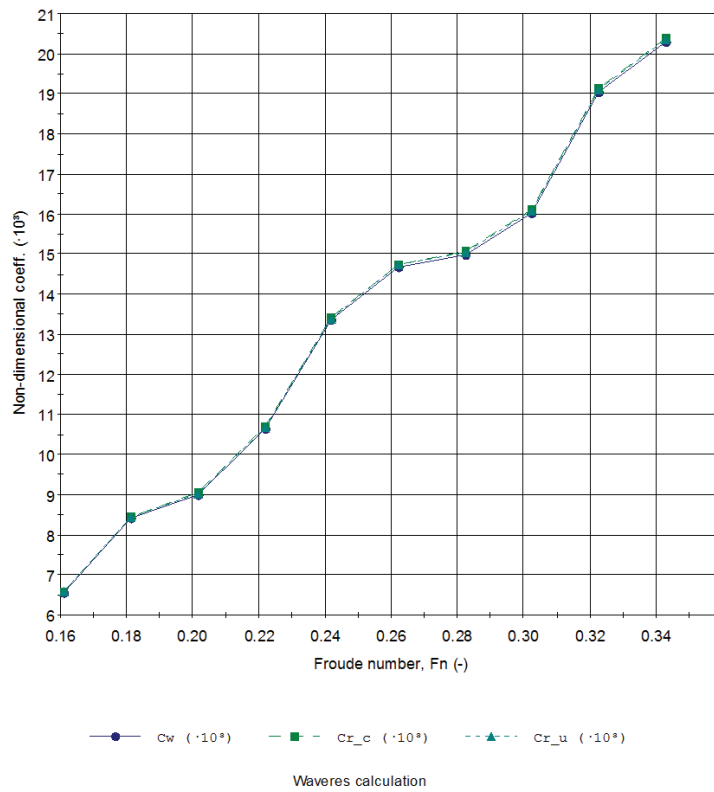

Waveres ver. 3.00.000 - 30/05/2017 - 22:42:13 - Licensed to: NTNU (NTNU)

## E.9 Resistance Calculations

**Draft = 0.515 meters**

|  |            |                   |
|--|------------|-------------------|
| Lpp  | 9          | m                 |
| LWL  | 8.85       | m                 |
| B  | 3.63       | m                 |
| T  | 0.515      | m                 |
| S  | 27.53      | m                 |
| A <sub>T</sub>                               | 7.463      | m <sup>2</sup>    |
| Displ  | 7.48       | m <sup>3</sup>    |
| C <sub>D</sub>                               | 0.8        |                   |
|  |            |                   |
| Kinematic viscosity                          | 1.88E-06   | m <sup>2</sup> /s |
| Density sea water                            | 1025       | kg/m <sup>3</sup> |
| Density air                                  | 1.25       | kg/m <sup>3</sup> |
| Roughness hull                               | 150        | μm                |
| C <sub>AA</sub> (air resistance coefficient) | 0.00026447 |                   |
|  |            |                   |
| η <sub>T</sub>                               | 50         | %                 |
|  |            |                   |
| Form factor (calculated ShipX)               | 1.565      |                   |

| Velocity | Velocity |  | Froude Number | Reynolds Number | Frictional Resistance Coefficient |
|----------|----------|--|---------------|-----------------|-----------------------------------|
| V [knot] | V [m/s]  |  | Fn            | Rn              | Cf                                |
| 2.92     | 1.4892   |  | 0.161         | 7.00E+06        | 0.002921                          |
| 3.29     | 1.6779   |  | 0.181         | 7.89E+06        | 0.002863                          |
| 3.65     | 1.8615   |  | 0.202         | 8.75E+06        | 0.002813                          |
| 4.02     | 2.0502   |  | 0.222         | 9.64E+06        | 0.002768                          |
| 4.38     | 2.2338   |  | 0.242         | 1.05E+07        | 0.002728                          |
| 4.75     | 2.4225   |  | 0.262         | 1.14E+07        | 0.002692                          |
| 5.11     | 2.6061   |  | 0.282         | 1.22E+07        | 0.00266                           |
| 5.48     | 2.7948   |  | 0.303         | 1.31E+07        | 0.00263                           |
| 5.85     | 2.9835   |  | 0.323         | 1.40E+07        | 0.002603                          |
| 6.21     | 3.1671   |  | 0.343         | 1.49E+07        | 0.002577                          |
| 5        | 2.55     |  |               | 1.20E+07        |                                   |

| Roughness Resistance Coefficient | Viscosity Resistance Coefficient | Residual Resistance Coefficient | Total Resistance Coefficient | Total Resistance |
|----------------------------------|----------------------------------|---------------------------------|------------------------------|------------------|
| $\Delta C_f$                     | $C_v$                            | $C_R$                           | $C_T$                        | $R_T$ [N]        |
| -0.000515989                     | 0.006168853                      | 0.006587                        | 1.30E-02                     | 4.07E+02         |
| -0.000424472                     | 0.006254825                      | 0.008442                        | 1.50E-02                     | 5.94E+02         |
| -0.000348507                     | 0.006321426                      | 0.009049                        | 1.56E-02                     | 7.64E+02         |
| -0.00028111                      | 0.006378872                      | 0.010698                        | 1.73E-02                     | 1.03E+03         |
| -0.0002235                       | 0.006424042                      | 0.013414                        | 2.01E-02                     | 1.42E+03         |
| -0.000171216                     | 0.00646581                       | 0.014743                        | 2.15E-02                     | 1.78E+03         |
| -0.000125671                     | 0.006500553                      | 0.015065                        | 2.18E-02                     | 2.09E+03         |
| -8.34465E-05                     | 0.00653191                       | 0.016112                        | 2.29E-02                     | 2.52E+03         |
| -4.51477E-05                     | 0.006560891                      | 0.01914                         | 2.60E-02                     | 3.26E+03         |
| -1.10339E-05                     | 0.006581703                      | 0.020397                        | 2.72E-02                     | 3.86E+03         |
|                                  |                                  |                                 |                              |                  |

| Effective (Towing) Power | Brake Power [W] |  |
|--------------------------|-----------------|--|
| $P_E$ [W]                | $P_B$ [W]       |  |
| 606.71                   | 1213.419715     |  |
| 997.17                   | 1994.332642     |  |
| 1422.93                  | 2845.865056     |  |
| 2108.49                  | 4216.980213     |  |
| 3161.43                  | 6322.856842     |  |
| 4307.15                  | 8614.298244     |  |
| 5451.65                  | 10903.29038     |  |
| 7055.81                  | 14111.6155      |  |
| 9729.10                  | 19458.19898     |  |
| 12210.77                 | 24421.54647     |  |
| 5100.00                  | 10200           |  |

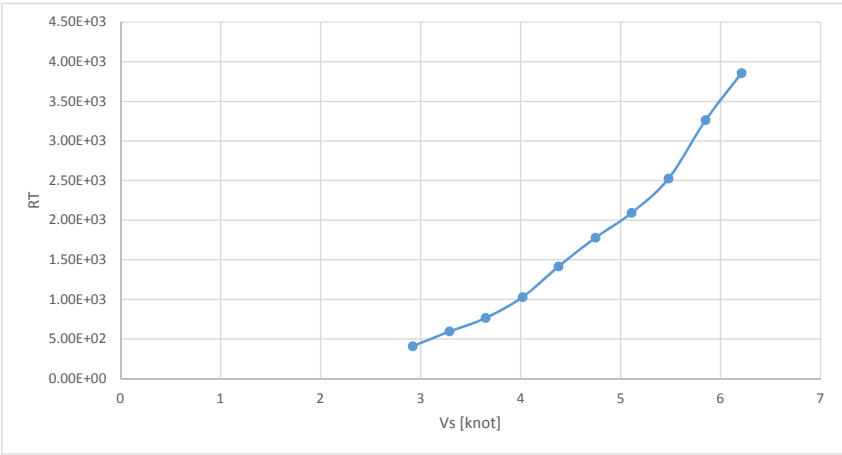

## E.10 Life Cycle Cost Calculation

### Investment cost

| Building cost          |               |               |               |           |
|------------------------|---------------|---------------|---------------|-----------|
| Aluminium              | 3631          | kg            |               |           |
| Work hours             | 112.5         | Hours         |               |           |
| Price aluminium        | 16.36         | Kr/kg         |               |           |
| Number of workers      | 4             |               |               |           |
| Hourly wage workers    | 230           | Kr            |               |           |
| 4.5% holiday pay       | 10            |               |               |           |
| 12% vacation pay       | 29            |               |               |           |
| 14.1% labor charge     | 38            |               |               |           |
| Brutto wage            | 307           |               |               |           |
| 10% personel cost      | 31            |               |               |           |
| Standard wage per hour | 338           |               |               |           |
| Hourly payment         | 538           |               |               |           |
|                        | Min           | Mean          | Max           |           |
| Aluminium              | 56433         | 59403         | 62373         | Kr        |
| Workers                | 229936        | 242038        | 254140        | Kr        |
| <b>Total</b>           | <b>286369</b> | <b>301441</b> | <b>316514</b> | <b>Kr</b> |

| Equipment cost                   |                      |               |                |                |    |
|----------------------------------|----------------------|---------------|----------------|----------------|----|
| Number of units                  | Equipment            | Min           | Mean           | Max            |    |
| 2                                | Pods                 | 150122        | 158023         | 165924         | Kr |
| 2                                | Battery module       | 290472        | 305760         | 321048         | Kr |
| 2                                | Hydraulick aggregat  | 8778          | 9240           | 9702           | Kr |
| 4                                | Hydraulick sylinders | 5852          | 6160           | 6468           | Kr |
| 2                                | Information screen   | 4180          | 4400           | 4620           | Kr |
| 1                                | Computer             | 16549         | 17420          | 18291          | Kr |
| 2                                | Sensors              | 129629        | 136452         | 143275         | Kr |
| 2                                | Surveillance         | 4051          | 4264           | 4477           | Kr |
| 24                               | Life jackets         | 8778          | 9240           | 9702           | Kr |
| 4                                | Fire detectors       | 3040          | 3200           | 3360           | Kr |
| 2                                | Fire extinguisher    | 665           | 700            | 735            | Kr |
| 2                                | Life bouy            | 3325          | 3500           | 3675           | Kr |
| 6                                | Novec                | 46216         | 48648          | 51080          | Kr |
|                                  | Piping               | 1140          | 1200           | 1260           | Kr |
|                                  | Cables               | 608           | 640            | 672            | Kr |
| 6                                | Bilge pumps          | 4721          | 4970           | 5218           | Kr |
| 2                                | Anchor               | 5434          | 5720           | 6006           | Kr |
| <b>Total</b>                     |                      | <b>683560</b> | <b>719537</b>  | <b>755513</b>  | Kr |
| <b>Sum total investment cost</b> |                      |               |                |                |    |
|                                  |                      | <b>Min</b>    | <b>Mean</b>    | <b>Max</b>     |    |
|                                  |                      | <b>969929</b> | <b>1020978</b> | <b>1072027</b> | Kr |



# Investment cost

|          |         |              |
|----------|---------|--------------|
| Dock     | 200 000 | per dock     |
| Elevator | 85400   | per elevator |
| Gangway  | 48500   | per gangway  |

|                        | <b>Min</b>    | <b>Mean</b>    | <b>Max</b>    |
|------------------------|---------------|----------------|---------------|
| Dock                   | 475000        | 500 000        | 525000        |
| Gangway                | 92150         | 97000          | 101850        |
| Elevator               | 162260        | 170800         | 179340        |
| Passenger registration | 76000         | 80 000         | 84000         |
| <b>Total</b>           | <b>805410</b> | <b>847 800</b> | <b>890190</b> |

# Operating cost

|                      |             |       |
|----------------------|-------------|-------|
| Market rate          | 5 %         |       |
| Operating time (n)   | 15          | years |
| Present value factor | 10.37965804 |       |

## Power supply

|                           |        |        |
|---------------------------|--------|--------|
| Price electricity         | 0.355  | Kr/kWh |
| Number of batteries       | 2      | pc     |
| Capacity per battery      | 30 000 | W      |
| Total capacity            | 60000  | W      |
| Total capacity kWh        | 52     | kWh    |
| Electricity used per year | 17000  | kWh    |

## Per year

|                  | Min  | Mean | Max  |
|------------------|------|------|------|
| Cost electricity | 5733 | 6035 | 6337 |

## Present value

|                         | Min          | Mean         | Max          |
|-------------------------|--------------|--------------|--------------|
| <i>Cost electricity</i> | <i>59509</i> | <i>62641</i> | <i>65773</i> |

## New batteries

|                 |        |
|-----------------|--------|
| Price batteries | 305760 |
|-----------------|--------|

## Present value

|                         | Min    | Mean   | Max    |
|-------------------------|--------|--------|--------|
| New batteries, 10 years | 178325 | 187710 | 197096 |

| Sum total operating cost | Min        | Mean        | Max       | Kr |
|--------------------------|------------|-------------|-----------|----|
|                          | 237833.785 | 250351.3527 | 262868.92 |    |

# Operating cost

|                      |           |       |
|----------------------|-----------|-------|
| Market rate          | 5 %       | years |
| Operating time (n)   | 15        |       |
| Present value factor | 10.379658 |       |

## Passenger registration

|           |      |
|-----------|------|
| Per month | 700  |
| Per year  | 8400 |

## Present value

|              | Min   | Mean  | Max   |
|--------------|-------|-------|-------|
| Cost support | 82830 | 87189 | 91549 |

## Electricity

|                      |       |        |
|----------------------|-------|--------|
| Price electricity    | 0.355 | Kr/kWh |
| Electricity per year | 8500  | kWh    |

## Present value

|                  | Min   | Mean  | Max   |
|------------------|-------|-------|-------|
| Cost electricity | 83816 | 88227 | 92638 |

| Sum total operating cost | Min    | Mean   | Max       |
|--------------------------|--------|--------|-----------|
|                          | 166645 | 175416 | 184187 Kr |

# Maintenance cost

|                      |           |       |
|----------------------|-----------|-------|
| Market rate          | 5 %       |       |
| Operating time (n)   | 15        | years |
| Present value factor | 10.379658 |       |

## Vessel still in water

|                   |     |           |
|-------------------|-----|-----------|
| Number of times   | 4   | pr year   |
| Hours per time    | 8   |           |
| Hourly payment    | 538 | Kr / hour |
| Number of workers | 1   |           |

## Vessel out of water

|                   |      |           |
|-------------------|------|-----------|
| Number of times   | 1    | pr year   |
| Hours per time    | 8    |           |
| Hourly payment    | 538  | Kr / hour |
| Number of workers | 1    |           |
| Cost for dock     | 1500 | Kr / hour |

## Per year

|                       | Min               | Mean              | Max               |
|-----------------------|-------------------|-------------------|-------------------|
| Vessel still in water | 16351.0315        | 17211.6121        | 18072.1927        |
| Vessel out of water   | 15487.7579        | 16302.903         | 17118.0482        |
| <b>Total</b>          | <b>31838.7894</b> | <b>33514.5152</b> | <b>35190.2409</b> |

## Present value

|                       | Min           | Mean          | Max           |
|-----------------------|---------------|---------------|---------------|
| Vessel still in water | 169718        | 178651        | 187583        |
| Vessel out of water   | 160758        | 169219        | 177679        |
| <b>Total</b>          | <b>330476</b> | <b>347869</b> | <b>365263</b> |

# Maintenance cost

|                      |           |       |
|----------------------|-----------|-------|
| Market rate          | 5 %       |       |
| Operating time (n)   | 15        | years |
| Present value factor | 10.379658 |       |

## Maintenance of elevator

|                   |     |           |
|-------------------|-----|-----------|
| Number of times   | 4   | pr year   |
| Hours per time    | 4   |           |
| Hourly payment    | 538 | Kr / hour |
| Number of workers | 1   |           |

## Per year

| Min  | Mean | Max  |
|------|------|------|
| 8176 | 8606 | 9036 |

## Present value

| Min   | Mean  | Max   |
|-------|-------|-------|
| 84859 | 89325 | 93792 |

# Life Cycle Cost Vessel

|                              |                 | <b>Min</b> | <b>Mean</b> | <b>Max</b> |
|------------------------------|-----------------|------------|-------------|------------|
| <b><i>Present values</i></b> | Investment cost | 969929     | 1020978     | 1072027    |
|                              | Operation cost  | 237834     | 250351      | 262869     |
|                              | Maintenance     | 330476     | 347869      | 365263     |
|                              | Sales value     | 373242     | 392886      | 412531     |

| <b>LCC for vessel</b> |                         | <b><i>Min</i></b>     | <b><i>Mean</i></b>    | <b><i>Max</i></b>     |
|-----------------------|-------------------------|-----------------------|-----------------------|-----------------------|
|                       |                         | <b><i>1164997</i></b> | <b><i>1226312</i></b> | <b><i>1287628</i></b> |
|                       | Rounded to closest 1000 | 1165000               | 1227000               | 1288000               |

# Life Cycle Cost Total

|                              |                         | <b>Min</b> | <b>Mean</b> | <b>Max</b> |
|------------------------------|-------------------------|------------|-------------|------------|
| <b><i>Present values</i></b> | Investment cost vessel  | 969929     | 1020978     | 1072027    |
|                              | Investment cost dock    | 805410     | 847800      | 890190     |
|                              | Operation cost vessel   | 237834     | 250351      | 262869     |
|                              | Operation cost dock     | 166645     | 175416      | 184187     |
|                              | Maintenance cost vessel | 330476     | 347869      | 365263     |
|                              | Maintenance cost dock   | 84859      | 89325       | 93792      |
|                              | Sales value             | 373242     | 392886      | 412531     |

| <b>LCC for vessel</b> |                         | <b><i>Min</i></b>     | <b><i>Mean</i></b>    | <b><i>Max</i></b>     |
|-----------------------|-------------------------|-----------------------|-----------------------|-----------------------|
|                       |                         | <b><i>2221911</i></b> | <b><i>2338854</i></b> | <b><i>2455797</i></b> |
|                       | Rounded to closest 1000 | 2222000               | 2339000               | 2456000               |

| <b>Price of</b>      | <b>Reference</b>                          |
|----------------------|---|
| Pods                 | (Torqeedo, 2017)                          |
| Batteries            | (Plan B Energy Storage, 2017)             |
| Hydraulick pump      | (TAON, 2017b)                             |
| Hydraulick sylinders | (TAON, 2017a)                             |
| Information screen   | (Lefdal, 2017)                            |
| Computer             | (Logic Supply, 2017)                      |
| Sensors              | (Velodyne Lidar, 2017)                    |
| Surveillance         | (CCTV Cameras Pros, 2017)                 |
| Life jackets         | (Clas Ohlson, 2017a) (Clas Ohlson, 2017b) |
| Fire detectors       | (Røde Kors, 2017)                         |
| Fire extinguisher    | (Jula, 2017)                              |
| Life bouy            | (BestMarin, 2017)                         |
| Novec tanks          | (Marine Outlet, 2017)                     |
| Piping               | (Maxbo, 2017)                             |
| Cables               | (Elektroimportøren, 2017)                 |
| Anchor               | (Waveinn, 2017)                           |
| Gangway              | (Skjærgårdsbrygger AS, 2017)              |
| Dock                 | (Johnsen Maskin, 2017)                    |
| Aluminium            | (London Metal Exchange, 2017)             |
| Electricity          | (Statistisk Sentralbyrå, 2017)            |
| Wage - Welder        | (Utdanning.no, 2017)                      |



## Bibliography

- BestMarin (2017). Livbøye m/kasteline - rina godkjent, orange. <https://www.bestmarin.no/produkter/sikkerhetsutstyr/livboeyer/livboeye-m-kasteline---rina-godkjent--orange-p1022943>. Retrieved: 24.05.2017.
- CCTV Cameras Pros, . (2017). Hd-tvi camera, indoor / outdoor dome, 1080p cctv surveillance camera. <https://www.cctvcamerapros.com/Outdoor-Dome-HD-TVI-Camera-p/hd-tvi-ad8.htm>. Retrieved: 26.05.2017.
- Clas Ohlson, . (2017a). Baltic 1240 redningsvest, barn. <http://www.clasohlson.com/no/Baltic-1240-redningsvest./Pr310894002>. Retrieved: 24.05.2017.
- Clas Ohlson, . (2017b). Baltic 1240 redningsvest, voksen. <http://www.clasohlson.com/no/Baltic%201240%20redningsvest./Pr310894002>. Retrieved:24.05.2017.
- Elektroimportøren (2017). Downlightkabel rxkx 90 2x1,5 bunt 25 m. <https://www.elektroimportoren.no/downlightkabel-rxkx-90-2x1-5-bunt-25-m/59344/Product.html?Event=showwindow>. Retrieved: 26.05.2017.
- Johnsen Maskin, . (2017). Prislister flytebrygger. <http://www.flytebrygger.no/side-prislister.html>. Retrieved: 26.05.2017.
- Jula (2017). Pulverbrannslukningsapparat 6 kg. <http://www.jula.no/catalog/hjem-og-husholding/brann-og-sikkerhet/merke/brannslukningsapparater/pulverbrannslukningsapparat-442051/>. Retrieved: 24.05.2017.
- Lefdal (2017). Lenovo thinkvision t2424p 23,8" skjerm. <https://www.lefdal.com/product/data/pc-skjerm/LE60F7MAT1EU/lenovo-thinkvision-t2424p-23-8-skjerm-sort>. Retrieved: 24.05.2017.
- Logic Supply, . (2017). Industrial intel skylake fanless nuc computer. <https://www.logicsupply.com/eu-en/m1100g-50/>. Retrieved: 26.05.2017.
- London Metal Exchange, . (2017). Lme aluminium. <http://www.lme.com/metals/non-ferrous/aluminium/>. Retrieved: 26.05.2017.
- Marine Outlet, . (2017). Brannslukker for små rom (2.8 m3) m. novec

1230, "nfg-100m", sea-fire. <https://www.marineoutlet.no/products/brannslukker-for-sma-rom-2-8-m3-novec-1230-sea-fire>. Retrieved: 26.05.2017.

Maxbo (2017). Rør rundt alu 16x2000 mm. Brannslukkerforsmårom(2.8m3)m. Novec1230, "NFG-100M", SEA-FIRE. Retrieved: 26.05.2017.

Plan B Energy Storage, . (2017). Meeting 24.04.2017. Personal communication. Retrieved: 24.04.2017.

Røde Kors, . (2017). Deltronic brannvarsler trådløs. [http://www.rodekorsforstehjelp.no/display.aspx?menuid=27&prodid=2&gclid=CjwKEAiAuc\\_FBRD7\\_JCM3NSY92wSJABbVoxB2CM9nBf-dgCZBGDMc3QS93hI\\_p-QBHg5IPfoYf5whhoC3MXw\\_wcB](http://www.rodekorsforstehjelp.no/display.aspx?menuid=27&prodid=2&gclid=CjwKEAiAuc_FBRD7_JCM3NSY92wSJABbVoxB2CM9nBf-dgCZBGDMc3QS93hI_p-QBHg5IPfoYf5whhoC3MXw_wcB). Retrieved: 24.05.2017.

Skjærgårdsbrygger AS, . (2017). Landgang i stål. <http://www.brygge.com/index.php?url=3/195/landgang-st%C3%A5l>. Retrieved: 26.05.2017.

Statistisk Sentralbyrå, . (2017). Elektrisitetspriser, 4. kvartal 2016. <https://www.ssb.no/elkraftpris/>. Retrieved: 26.05.2017.

TAON (2017a). Fastøye: Ø40/25. <https://taon.dk/no/dobbeltvirkende-fastoeye-80/fastoeye-oe40-25-p991>. Retrieved: 24.05.2017.

TAON (2017b). M1/1258 (24 volt). <https://taon.dk/no/mobile-12v-24v-20/m1-1258-24-volt-p1957>. Retrieved: 24.05.2017.

Torqueedo (2017). Electric boating - product catalogue. <http://media.torqueedo.com/catalogs/torqueedo-catalog-2017-en.pdf>. Retrieved: 23.05.2017.

Utdanning.no, . (2017). Yrkesbeskrivelse sveiser. <https://utdanning.no/yrker/beskrivelse/sveiser#lonn>. Retrieved: 26.05.2017.

Velodyne Lidar, . (2017). Puck vlc-16. <http://velodynelidar.com/vlp-16.html>. Retrieved: 23.05.2017.

Waveinn (2017). Plastimo kobra 2 fixed 20. [https://www.waveinn.com/nautisk-fiske/plastimo-kobra-2-fixed-%2020/1333430/p?utm\\_source=google\\_products&utm\\_medium=merchant&id\\_producte=1794381&country=no&gclid=Cj0KEQjw0v\\_IBRCEzKHK0KiCrKMBeIQa3--1Ni6m\\_IAU0IkvdxfMHsKe0ChN5rC\\_GlbpUWvECAFEn6UaAsza8P8HAQ&gclidsrc=aw.ds](https://www.waveinn.com/nautisk-fiske/plastimo-kobra-2-fixed-%2020/1333430/p?utm_source=google_products&utm_medium=merchant&id_producte=1794381&country=no&gclid=Cj0KEQjw0v_IBRCEzKHK0KiCrKMBeIQa3--1Ni6m_IAU0IkvdxfMHsKe0ChN5rC_GlbpUWvECAFEn6UaAsza8P8HAQ&gclidsrc=aw.ds). Retrieved: 26.05.2017.

## F Appendix: Electronic Files

The electronic files are found by searching for the thesis at: <https://brage.bibsys.no/>

Filename: ElectronicFilesAppendix

1. PHA (PHA.xlsx)
2. ETA (ETA.xlsx)
3. ETA With Risk Reducing Measures (ETARiskReduced.xlsx)
4. Operational Profile Revision 1 (OperationalProfile1.xlsx)
5. Operational Profile Revision 2 (OperationalProfile2.xlsx)
6. Stability- and Strength Report IMO Criteria (StabilityReportIMOCriteria.pdf)
7. Stability- and Strength Report IMO Criteria with Ballast (StabilityReportIMOCriteriaWithBallast.pdf)
8. Stability- and Strength Report Adapted Criteria (Stabilityreportadaptedcriteria.pdf)
9. Stability- and Strength Report Adapted Criteria with Ballast (StabilityReportAdaptedCriteriaWithBallast.pdf)
10. Technical Drawings (See table, Filenames Sorted Accordingly)

| File Name(.pdf/.dwg) and Drawing No. | Title                      |
|--------------------------------------|----------------------------|
| 1                                    | General Arrangement        |
| 2                                    | Arrangement                |
| 3                                    | Line Drawing               |
| 4                                    | Midship Section Drawing    |
| 5                                    | Bilge System               |
| 6                                    | Fire Fighting System       |
| 7                                    | Cooling System for Battery |
| 8                                    | Mooring System             |
| 9                                    | Lantern System             |
| 10                                   | El scheme                  |
| 11                                   | Fire Fighting Scheme       |