



Norwegian University of  
Science and Technology

# Mitigation of Subsynchronous Resonance with Thyristor Controlled Series Compensation in the Great Britain Power Network

**Espen Fossen**

Master of Science in Electric Power Engineering

Submission date: June 2016

Supervisor: Olimpo Anaya-Lara, ELKRAFT

Co-supervisor: Raymundo Enrique Torres-Olguin, ELKRAFT

Norwegian University of Science and Technology  
Department of Electric Power Engineering



## **Problem description**

One of the greatest challenges in the modern power sector is increased power demand and the integration of renewable energy sources. This is especially a challenge when the energy sources are located in other geographical areas than the energy demand.

The Great Britain power network is an example of such a system where large power transfer is needed. Here series compensation can be part of the solution. When series compensating, more power can be transferred without construction of new lines. However a by-product of series compensation can be resonance between the mechanical and electrical part of the system, this is called subsynchronous resonance. In this thesis, mitigation of this in the Great Britain power network is studied with the use of thyristor controlled series compensation.

## Preface

This master thesis aims to study the possible mitigation of Subsynchronous Resonance in a series compensated Great Britain transmission network, with the use of Thyristor Controlled Series Compensation (TCSC). The thesis is ending a two year masters program in Electric Power Engineering at NTNU and is carried out during the spring of 2016. The readers background is assumed to be on a Bachelor/Masters level in Electric Power Engineering. The cover picture is a TCSC delivered by ABB, operating in Imperatriz, Brazil.

Trondheim, 2016-06-07

sign.



Espen Fossen

## **Acknowledgment**

First I would like to thank Olimpo Anaya-Lara, Professor at the Department of Electric Power Engineering at Norwegian University of Science and Technology and at the University of Strathclyde Glasgow, for being my main supervisor. Olimpo has provided the thesis, and he has been helping me with problems and guided me on to the right path throughout the thesis work.

I would also like to thank Raymundo Enrique Torres-Olguin, Postdoctoral at the Departure of Electrical Engineering at Norwegian University of Science and Technology, for being my co-supervisor, helping me with problems and especially simulation issues. I very much appreciate that he has prioritized to use time on me and this thesis.

As this thesis is the last work in my master's degree, I would also like to thank my fellow students, friends, family and girlfriend for being supportive, and part of my life throughout my time studying.

E.F.

## Summary

In this thesis, the use of thyristor controlled series compensation (TCSC) are studied as a tool to mitigate resonance between the mechanical and electrical part of a series compensated Great Britain power network. A literature study on the field is performed, and simulation tools are used to test cases in the network. The network and TCSC are designed and modeled, simulations run and results analyzed.

The results from simulations have proved that with fixed compensation there is a limited amount of power that can be transferred, and that mitigation of resonance is needed. It is shown that the TCSC indeed mitigates the resonance, making it possible to increase compensation and hence power transfer to a higher level. It is noted that the variable compensation device also contributes to a more stable system in other ways than mitigating of resonance.

## Sammendrag

I denne masteroppgaven er bruken av thyristorkontrollert seriekompensering (TCSC) vurdert som en mulighet for å redusere og dempe resonans mellom den mekaniske og elektriske delen av Storbritanias seriekompenserte kraftnett. En litteraturstudie på området ble gjennomført og simuleringsverktøy er brukt for å teste ulike scenarioer i nettet. Nettet og TCSC er designet og modellert, simuleringer gjennomført og resultater analysert.

Resultatene fra simuleringene har bevist at det er begrenset hvor mye kraft som kan overføres med vanlig seriekompensering før det blir resonans og at tiltak trengs om kraftoverføringen skal økes. Det blir vist at TCSC demper resonansen og gjør det mulig å øke kraftflyten. Det er også bemerket at den variable kompenseringen gjør systemet mer stabilt utover det å dempe resonans.

## **Acronyms**

**TCSC** Thyristor Controlled Series Compensation

**SSO** Subsynchronous Oscillations

**SSR** Subsynchronous Resonance

**FACTS** Flexible AC Transmission Systems

**IEEE FBM** Institute of Electrical and Electronics Engineers First Benchmark Model



# Contents

Preface . . . . .	ii
Acknowledgment . . . . .	iii
Summary . . . . .	iv
Sammendrag . . . . .	v
Acronyms . . . . .	vi
<b>1 Introduction</b>	<b>1</b>
1.1 Background . . . . .	2
1.2 Assumptions . . . . .	4
1.3 Methodology . . . . .	4
1.4 Scope of work . . . . .	5
1.5 Structure of the Report . . . . .	5
<b>2 Reactive Power Compensation and Subsynchronous Oscillations</b>	<b>6</b>
2.1 Reactive Power and Reactive Power Compensation . . . . .	7
2.2 Series Reactive Power Compensation . . . . .	9
2.3 Variable Reactive Power Compensation . . . . .	11
2.4 Thyristor Controlled Series Compensation . . . . .	12
2.4.1 TCSC Blocking mode . . . . .	13
2.4.2 TCSC Bypass mode . . . . .	13
2.4.3 TCSC Phase controlled mode . . . . .	13
2.4.4 Design of TCSC . . . . .	16
2.5 Subsynchronous Oscillations . . . . .	18
2.5.1 Subsynchronous Resonance . . . . .	22

<b>3</b>	<b>System modeling and results</b>	<b>23</b>
3.1	Model of Power System . . . . .	24
3.2	Implementing Multimass and increasing Fixed Compensation . . . . .	27
3.3	Implementing TCSC . . . . .	29
3.4	TCSC with Controller in Closed loop . . . . .	31
3.5	Modeling of System with double lines from Northern Scotland . . . . .	33
3.6	Reactive Power Event . . . . .	35
3.7	Power Outage Event . . . . .	37
<b>4</b>	<b>Summary and Further Work</b>	<b>39</b>
4.1	Discussion . . . . .	40
4.2	Conclusion . . . . .	43
4.3	Further Work . . . . .	44
	<b>Bibliography</b>	<b>45</b>
<b>A</b>	<b>Great Britain Power System Information</b>	<b>I</b>
A.1	Lines . . . . .	II
A.2	Loads . . . . .	II
A.3	Transformers . . . . .	II
A.4	Generators . . . . .	III
A.4.1	Synchronous Generator . . . . .	III
A.4.2	Exciters . . . . .	III
A.4.3	Governors and Turbines . . . . .	IV
A.4.4	Multimass in Northern Scotland Generator . . . . .	IV
<b>B</b>	<b>Study case data</b>	<b>V</b>
<b>C</b>	<b>Model in PSCAD</b>	<b>VI</b>

# List of Tables

2.1	Sizes and ratings of some TCSCs in operation around the world . . . . .	17
2.2	Modes of IEEE FBM six mass model . . . . .	21
3.1	Summary of study cases in thesis . . . . .	24
3.2	Great Britain power system model parameters . . . . .	25
3.3	Inertias, Torotional stiffness, self and mutual damping coefficients of IEEE FBM model for SSR. . . . .	27
A.1	Line data . . . . .	II
A.2	Load data . . . . .	II
A.3	Transformer data . . . . .	II
A.4	Synchronous generator data . . . . .	III
A.5	Excitor data . . . . .	III
A.6	Governor and Turbine data . . . . .	IV
A.7	Inertias, Torotional stiffness, self and mutual damping coefficients of IEEE FBM model for SSR. . . . .	IV
B.1	Study case data . . . . .	V

# List of Figures

1.1	Flowchart of the steps taken in thesis. . . . .	4
2.1	Simplified transmission line equivalent circuit . . . . .	8
2.2	Simplified transmission line equivalent circuit with series compensation . . . . .	10
2.3	Fixed series capacitor system delivered by ABB in Asmunti, Finland . . . . .	10
2.4	Equivalent circuit of the TCSC . . . . .	12
2.5	Simplified equivalent circuit of the TCSC. . . . .	14
2.6	Example of TCSC impedance level as a function of firing angle. . . . .	15
2.7	TCSC system delivered by ABB in Imperatriz, Brazil. . . . .	15
2.8	Example of TCSC impedance levels as a function of firing angle for different capacitor and inductor values arranged by $\frac{\omega_r}{\omega_1}$ relationships. . . . .	17
2.9	Simplified mass representation of parts of a steam turbine rotor . . . . .	19
2.10	Mass representation of parts of a steam turbine rotor with inertia, stiffness and damping constants. . . . .	19
2.11	Mechanical representation of a four mass turbine generator . . . . .	20
3.1	Great Britain power system model . . . . .	25
3.2	Active power flow in Northern Scotland line as a function of % compensation. . . . .	26
3.3	Mechanical representation of IEEE FBM model for SSR. . . . .	27
3.4	Electrical frequency in the system at different levels of % compensation. . . . .	28
3.5	Model of power system with both fixed compensation and TCSC. . . . .	29
3.6	Electrical frequency in the two simulated systems with equal degree of compensation. . . . .	30

3.7 Active power flow in Northern Scotland line as a function of % compensation with both fixed compensation and fixed combined with TCSC. . . . . 31

3.8 Closed loop controller used with the TCSC. . . . . 32

3.9 Electrical frequency of system and firing angle when TCSC is closed loop controlled. 32

3.10 Power system model with double lines, fixed compensation and TCSC in one of the lines. . . . . 33

3.11 Power system model with double lines, fixed compensation in both and TCSC in one line. . . . . 34

3.12 Electrical frequency response when active power is controlled in one of the two parallel lines. . . . . 34

3.13 System with both fixed compensation and TCSC. Reactive power event. . . . . 35

3.14 Electrical frequency response to reactive power event. Open and closed loop including firing angle. . . . . 36

3.15 System with both fixed compensation and TCSC. Loss of active power event. . . . 37

3.16 Electrical frequency response to active power outage event. Open and closed loop including firing angle. . . . . 38

# Chapter 1

## Introduction

*This chapter gives an introduction to the work done. The chapter consists of a background section, containing the problem, the objective and an overview of the literature studied. After this comes a section with the relevant assumptions made in the project work. The methodology and scope of work are explained and lastly the structure of the rest of the report is presented.*

## 1.1 Background

Some of the greatest challenges in the modern power sector are increased power demand and the integration of renewable energy sources. These challenges are especially prominent when the energy sources are located in other geographical areas than the energy demand. With the global warming challenge and large population growth combined with urbanization, there has been an escalating demand and acceptance for both locally and globally environmental-friendly solutions when constructing and reinforcing power systems. Increased power transfer by the use of compensation is one of the solutions to this challenge. Reinforcement, by reactive power compensation is increasingly important as opposed to conventional construction of new lines due to the smaller footprint it has on the local and global environment.

Great Britain is one example of a power system with the challenges described. In this thesis, the Great Britain power network will be studied with respect to reactive power compensation, its challenges, mostly subsynchronous resonance and how to mitigate it. Great Britain has a large need for an increased power flow between the north and the south of the island. There is a great production surplus in the north due to much hydro power and other emerging renewable energy production, and in the south there is a production deficit due to a high population.

It has been known a long time that compensation with fixed capacitors in series, is a both cost and resource effective way of improving power flow compared to conventional construction of new lines. A typical problem with fixed series compensation however, can be subsynchronous resonance (SSR). The compensation changes the electrical natural frequency of the system, and it can become near the frequency of mechanical oscillations from the generators, causing resonance between the electrical and mechanical system. This resonance will lead to failure of the system if correct measures are not taken.

The objective of this thesis is to study the use of thyristor controlled series compensation (TCSC) as a substitute or addition to the fixed compensation. TCSC can potentially mitigate the SSR. The TCSC is a reactive power compensating FACTS device with many benefits such as variable compensation and power control.

Reactive power compensation have been used almost as long as AC electric power. In 1977 the researchers F. Illicento and E. Cinieri published a paper named: "Comparative Analysis of Se-

ries and Shunt Compensation Schemes for AC Transmission Systems", so series compensation have also been studied a long time. Up until the 1950s, the compensated reactive power was adjusted by manual switching, but when W. Shockleys thyristor was invented [1], variable reactive power compensation was much more accessible. Today variable reactive power compensation is done by FACTS devices. The TCSC is one of these devices. The technology is relatively new, and there is currently eight TCSC in operation around the world today. This means that there is room for more research on the TCSC device and its effect on power systems.

The literature studied for the work on this thesis is mainly books and articles. Some Phd. theses, IEEE standards, and industry product references are also cited. In the project work prior to this thesis, books such as *Understanding FACTS*, *Thyristor Based FACTS Controllers for Electrical Transmission Systems*, *Standard Handbook for Electrical Engineers* and *Power System Stability and Control* were much used to understand the operation and benefits of the TCSC. A chapter in the book *Power Electronic Control in Electrical Systems* has been especially important for understanding the TCSC.

Several articles have been used to collect data for the design of the Great Britain network model, some of these are: [2][3].

To understand the concept of SSR, the books *Power System Stability and Control* (both the one from P. Kundur and the one from Machowski, Bialek and Bumby) are much used. The book *Power System Dynamics Stability and Control* is also used to some extent.

As mentioned there is currently not many TCSC in operation around the world. This thesis will build on and add to the studies of SSR mitigation with the TCSC. The fact that the TCSC will be studied on the Great Britain system will make the results more unique.



## 1.2 Assumptions

Following, the assumptions made in this thesis are listed:

- Great Britain power system is simplified to consist of only four buses. This simplification seems large, but the system has sufficiently details for many investigation purposes [3]. Here, all parameters are set to resemble actual power system parameters.
- A six mass model (IEEE FBM) is implemented in one generator to simulate the mechanical oscillations of the system leading to SSR.
- The transmission lines in the power system is represented with pi-equivalents.
- The transmission lines in the system are simplified in the sense that they have no resistance. There will of course be less loss of active power because of this, but will not affect SSR related measures such as natural system electrical frequency.

## 1.3 Methodology

The methodology is explained in the folloing flowchart, see Figure 1.1. A literature review was conducted before any other work on this thesis was done. Reactive compensation, fixed and TCSC was studied in addition to subsynchronous oscillations and subsynchronous resonance in particular. The model developed of the Great Britain power network in the previous project work was used, and more details were added to study the SSR. Among this, a *multimass model* was implemented in one of the generators. When SSR occurred, a TCSC was implemented in several cases and events to study its ability to mitigate SSR.

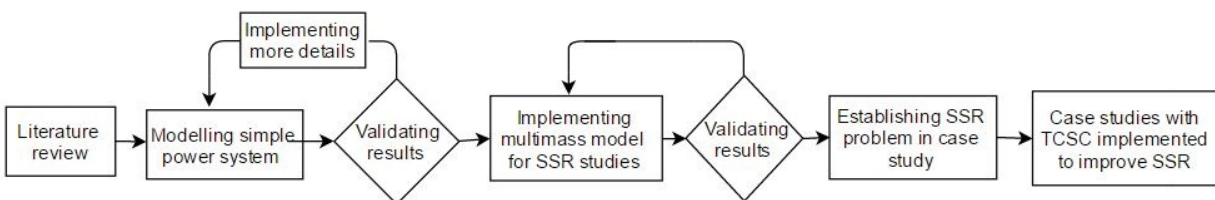

Figure 1.1: Flowchart of the steps taken in thesis.

## 1.4 Scope of work

Subsynchronous oscillations are not a large problem in most cases, but they must be accounted for if they interact with other dynamics of the system such as:

- Subsynchronous resonance with series compensated transmission lines.
- Power system controls, such as controls for FACTS or HVDC.
- Network switching and faults.

This thesis will mainly focus on the first item, subsynchronous resonance with series compensated transmission lines. The other two are also relevant, and the interaction with FACTS and HVDC is increasingly important as more renewable energy sources will be integrated in the future grid.

The scope of the work is to establish SSR in the Great Britain network simulation as it would appear in real life. After this, implement a TCSC in the network, study how it affect the system and if it can be used to mitigate SSR.

## 1.5 Structure of the Report

The rest of the report is structured as follows.

Chapter 2 provides the theoretical background necessary to understand the work described in this thesis. Here the topics will be focused on the reactive power, compensation, the TCSC and the SSR phenomena. The TCSC theory is studied with the goal to understand both the operation of the TCSC, and its impact on power systems.

In Chapter 3 the modeling, simulation and results are presented and described. Chapter 4 contains a discussion and conclusion section in addition to recommendations for further work.

## Chapter 2

# Reactive Power Compensation and Subsynchronous Oscillations

*This chapter contains the theoretical background needed to understand the work in this thesis.*

*First, reactive power, reactive power compensation and why it is needed is explained. Second sections on series and variable reactive power compensation are included. After this the TCSC and its effects on a power system are explained. The work on compensation and TCSC is based on an earlier project work.*

*Lastly a section on subsynchronous oscillation with focus on subsynchronous resonance is included to have an understanding of why and when it occurs, and what measures that can be taken to mitigate it.*

## 2.1 Reactive Power and Reactive Power Compensation

The main essence of reactive power in an AC power system is the angle difference between the voltage and current, i.e. if the current is lagging or leading the voltage. Reactive power can be both produced and consumed by generators, loads and transmission lines/cables.[4]

When transmitting or consuming power using alternating current, reactive elements in the network; inductors and capacitors, temporarily store energy in magnetic and electric fields respectively. An inductor storing energy in magnetic fields, is making the current lag the voltage ( $V = L \frac{di}{dt}$ ), while a capacitor storing energy in an electric field, making the current lead the voltage ( $i = C \frac{dV}{dt}$ ). These elements do not dissipate power, but have a contribution to the currents and voltage levels in the network, thereby indirectly affecting both stability, transmission capability and loss of active power[5].

The total impedance  $Z$  (reactance if purely inductive) of *one* line in a *circuit* is given by the sum of inductive and capacitive impedance  $Z_L$  and  $Z_C$  as follows

$$Z = Z_L + Z_C \quad (2.1)$$

where

$$Z_L = j\omega L, \quad Z_C = \frac{1}{j\omega C} \quad (2.2)$$

where  $L$  and  $C$  are the inductance and capacitance and  $\omega=2\pi f$  with  $f$  being the frequency of the system.

Equation (2.1) shows that if  $Z_L$  is larger than the absolute value of  $Z_C$ , the line in the circuit in total has an inductive impedance (reactance). A transmission line has an inductive series reactance and this is modeled with an inductor in the equivalent circuit. There is also shunt susceptance in every line, and this is modeled by shunt capacitor(s). In reality, an infinite amount of inductances and capacitances are distributed across the line, but is often represented as one or two large inductors/capacitors in the equivalent circuit. An example of this is shown in Figure 2.1.

The reactive power consumed or produced by a transmission line is mainly dependent of the series reactance of the line, but the shunt susceptance do also contribute. The reactive power

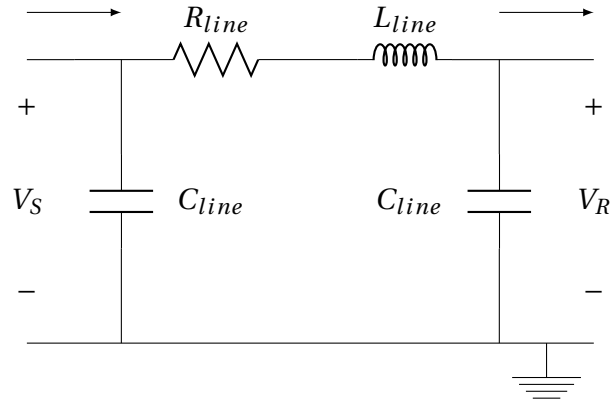

Figure 2.1: Simplified transmission line equivalent circuit

consumed by a line is given by

$$Q_{c \text{ line}} = I^2 Z_{L \text{ line}} \quad (2.3)$$

where  $I$  is the current flowing and  $Z_{L \text{ line}}$  is the series inductive reactance of the line.

The reactive power produced is given by

$$Q_{p \text{ line}} = \frac{V^2}{Z_{C \text{ line}}} \quad (2.4)$$

where  $V$  is the voltage level and  $Z_{C \text{ line}}$  is the parallel capacitive impedance of the line.

The total reactive power produced or consumed in a line is given by

$$Q_{total \text{ line}} = Q_{p \text{ line}} - Q_{c \text{ line}} \quad (2.5)$$

As equation (2.3) and (2.4) show, the consumed reactive power is depend on the current through the line while the produced reactive power depends on the voltage level. In a transmission lines the voltage is fairly constant and the loading (current) vary over time. This means that the total reactive power produced or consumed in the line given in equation (2.5) will vary [6].

In addition to the reasons mentioned earlier (stability, transmission capability and loss of active power) the right amount of reactive power is important to satisfy the costumers need for reactive loads.

If the reactive power consumed per km in a line is greater than the reactive power produced, long lines will consume large amounts of reactive power. To be able to satisfy the reactive power

demand, compensation can be used as an option to generators producing and lines transferring large amounts of reactive power.

There are two main methods of compensating reactive power; shunt and series compensation. Compensation units in parallel and series are tools to artificially change the shunt susceptance and series inductance of a transmission line.

There are many types of both shunt and series compensation; capacitors and inductors are used, both separately and placed together in parallel and often controlled by either mechanical switching or power electronics [4] [7] [8] [9] [10].

## 2.2 Series Reactive Power Compensation

The main purpose of series compensation is to increase the power flow in a line or lines in a network.

The active power flow of a transmission line is determined mainly by four variables:

$$P = \frac{V_S V_R}{X} \sin \delta \quad (2.6)$$

where  $V_S$  is the magnitude of the voltage at the sending end of the line,  $V_R$  on the receiving end.  $\delta$  is the angle difference between them, and  $X$  is the reactance of the line. See Figure 2.1 for a representation of a line. The active power flow can be manipulated by changing any one of these variables. When series compensating reactive power, a capacitor is placed in series with the transmission line. Its purpose is to virtually make the line shorter by counteracting the lines inductive reactance  $X$ .

While shunt compensation often is used to manipulate the voltage levels, and as a by-product changing the power flow, series compensation is the most effective alternative if the objective is to increase the power flow [4][10]. Series compensating is more effective than shunt compensation due to the fact that the reactive power from a series capacitor is proportional to the square of the current, as opposed to a shunt capacitor which is proportional to the square of the voltage. This makes the series capacitor 3-6 times more effective than the same capacitor placed in parallel [11]. A disadvantage is that the series capacitor must be fully insulated from

ground.

In long overhead lines the inductive series reactance consumes more reactive power than the shunt susceptance produce. This means that a long overhead lines in total consumes a large amount of reactive power and the voltage drop across the line is large. The need for compensation therefore arise. An effective way of compensating in this case, is to place a capacitor in series with the line, opposing the inductive series reactance, and reducing the *electrical length* of the line. A byproduct of this is that the *natural electrical frequency* of the system is changed and it can lead to SSR (this will be further explained in section 2.5). An equivalent circuit of a series compensated line is shown in Figure 2.2, and Figure 2.3 shows a 85  $\mu F$ , 369 MVar fixed capacitor delivered by ABB in Asmunti, Finland.

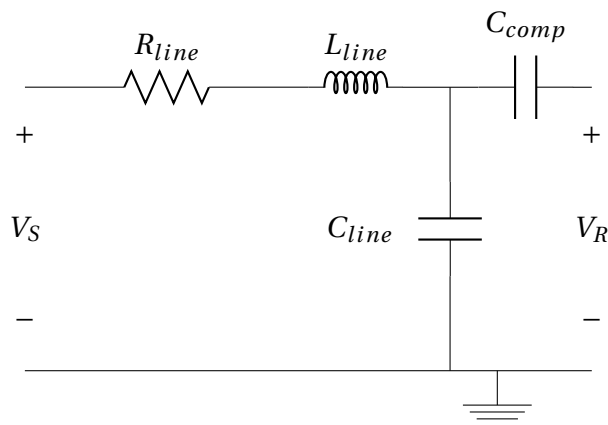

Figure 2.2: Simplified transmission line equivalent circuit with series compensation



Figure 2.3: Fixed series capacitor system delivered by ABB in Asmunti, Finland

When series compensating, the losses in the parallel/neighboring lines decrease due to the increased power flow in the compensated line. However, studies show that the total losses of the system will be greater than without the compensation, due to the increased loss in the compensated line (higher power flow). If there should be an outage of a line in parallel to a compensated line, the compensated line often exceeds its loadability level if it is already operated close to its limit. Both of these problems can be avoided if a variable level of compensation is used.

Placing variable compensation in series with the line instead of, or in addition to a fixed capacitor, makes it possible to also control the power flow in the line. This is also useful when demand is varying. Series compensation has many benefits compared with shunt compensation and some of these will be discussed in the next section [4][8][10][9][12].

## 2.3 Variable Reactive Power Compensation

It has been possible to provide a variable reactive power compensation for many years [1]. This can be done by placing multiple capacitors, inductors or both in either series or parallel with a line/bus, and manually switching them in and out. The manual switching means that the reactive power is compensated in steps. Here there is a compromise between number of capacitors/inductors and switches (price and complexity) and the smoothness of compensation (performance).

Power electronics makes it possible to have a continuous variable reactive power compensation. By using semiconductors with controlling capabilities such as thyristors (turn on capability) or gate turn off thyristors and transistors (turn on/off capability), reactive power can be varied if the semiconductors are controlled in a correct way. The current flowing through the semiconductors is controlled to vary continuously, and thereby reactive power is varied continuously. However this compensation technique comes at a price compared to the conventional switching technique; when thyristors and transistors are controlled and reactive power continuously varied, harmonics are injected to the system. Harmonics are components multiple of the fundamental frequency. These harmonics can damage equipment and give increased losses. Harmonic filtering may therefore be necessary [4][13].



## 2.4 Thyristor Controlled Series Compensation

The thyristor controlled series compensator (TCSC) is a device that is able to change the impedance of a transmission line rapidly, smoothly and continuously. This is done by placing a thyristor controlled reactor (TCR) in parallel with a fixed capacitor. This configuration is then placed in series with a transmission line.

Figure 2.4 shows the simplified equivalent of the TCSC. A practical module of the TCSC does also need some protection (much of the same protection is needed for the fixed compensation).

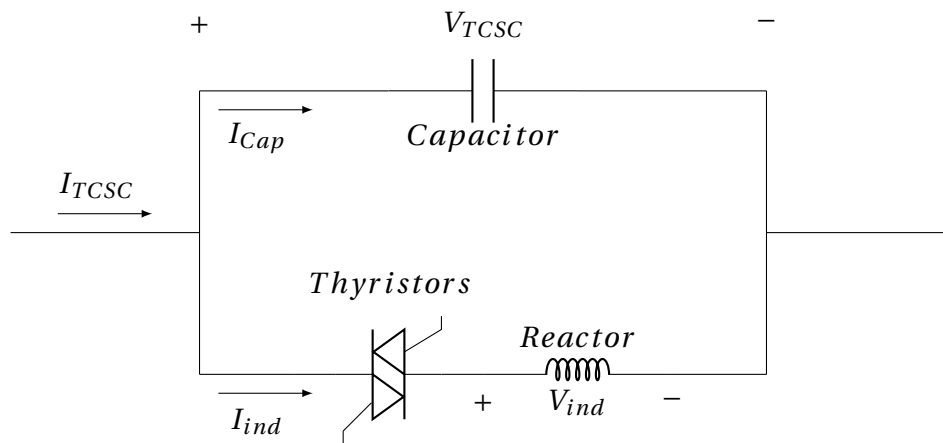

Figure 2.4: Equivalent circuit of the TCSC

The total impedance of the TCSC is determined by the current flowing through the capacitor and the inductor, respectively. The ability to control the thyristors makes it possible to control the total impedance. The thyristors are controlled by the firing angle  $\alpha$ . They can be fired when the capacitor voltage and current has the same polarity. Therefore it is only possible to fire the forward-connected thyristor in the range of  $90 - 180^\circ$  [14].

The thyristors can operate in three fundamental modes:

- Blocking mode
- Bypass mode
- Phase controlled mode

### 2.4.1 TCSC Blocking mode

In the first mode, the thyristors operate in the blocking mode ( $\alpha = 180^\circ$ ). All the current is flowing through the capacitor, making the total impedance

$$Z_{TCSC} = X_C \quad (2.7)$$

where  $Z_{TCSC}$  is the total impedance of the TCSC device and  $X_C$  is the reactance of the capacitor in the TCSC.

### 2.4.2 TCSC Bypass mode

In the second mode the thyristors operate in is the bypass mode ( $\alpha = 90^\circ$ ). Here the configuration would operate like if the thyristors where short circuited (bypassed), except for the small voltage drop over them. This makes the total impedance of the configuration equal to the parallel of  $X_C$  and  $X_L$ , ( $X_C \parallel X_L$ ) ie.

$$Z_{TCSC} = \frac{X_C X_L}{X_C + X_L} \quad (2.8)$$

where  $X_C$  is the reactance of the capacitor and  $X_L$  is the reactance of the inductor in the TCSC. In all TCSC designs this impedance is inductive because of the size of the inductor compared to the capacitor.

### 2.4.3 TCSC Phase controlled mode

In the third possible mode of the thyristors, the phase controlled mode, the firing angle could be anywhere in the range of  $90 - 180^\circ$ , except for the angles to close to the resonant point and very close to  $90$  or  $180^\circ$  (electrical resonance is when two impedances are equal and cancel each other out. This is for example at  $148^\circ$  in Figure 2.6). Firing the thyristors in this range ( $90 - 180^\circ$ ), creates a current flowing in the inductor. This current can, depending on the firing angle be either in the same direction as or oppose the capacitor current. The effect of this can be a loop flow in the circuit, which increases the voltage drop over the capacitor, and hence the overall

compensation. The formula for the total compensation is given in equation 2.9 [14][15].

$$Z_{TCSC} = -X_C + (X_C + X_{LC}) \frac{2\theta + \sin 2\theta}{\pi} - 4X_{LC}^2 \cos^2 \theta \frac{k \tan \theta - \tan \theta}{\pi X_L} \quad (2.9)$$

where

$$X_{LC} = \frac{X_C X_L}{X_C - X_L},$$

$$\theta = \pi - \alpha$$

and

$$k = \frac{\omega_o}{\omega}, \quad \omega_o = \sqrt{\frac{1}{LC}}, \quad \omega = 2\pi f$$

An example of the compensation with respect to the firing angle is given in Figure 2.6. This plot is produced by using equation (2.9).

To better understand this, a simplification can be made; looking at the circuit as a capacitor in parallel with a variable inductor, like shown in Figure 2.5. Now the total impedance will be like

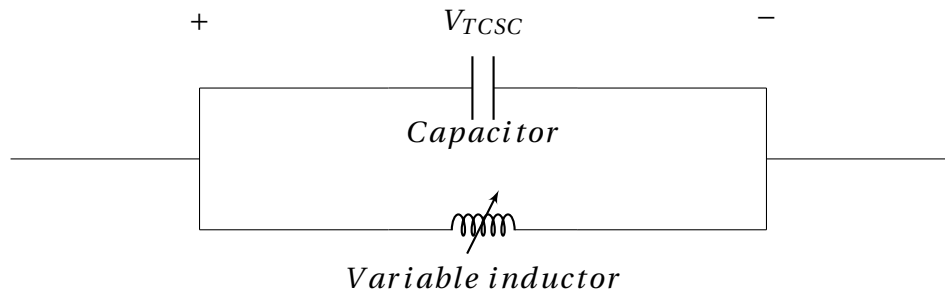

Figure 2.5: Simplified equivalent circuit of the TCSC.

equation (2.8) with a variable  $X_L$ . If equations (2.2) are inserted, the result will be

$$Z_{TCSC} = \frac{X_C X_L}{X_C + X_L} = -j \frac{1}{\omega C - \frac{1}{\omega L}} \quad (2.10)$$

where  $L$  is variable. From equation 2.10 one can see that if  $\omega C - \frac{1}{\omega L} > 0$  the impedance will be capacitive. If  $\omega C - \frac{1}{\omega L} < 0$  the impedance will be inductive. If  $\omega C - \frac{1}{\omega L} = 0$  there would be an electrical resonance between the capacitor and inductor and the impedance would be positive or negative infinite, depending on the sign of the impedance prior to  $\omega C - \frac{1}{\omega L} = 0$ . This is the reason for the asymptote in Figure 2.6.

Note that this simplification is not completely accurate because it implies that the currents

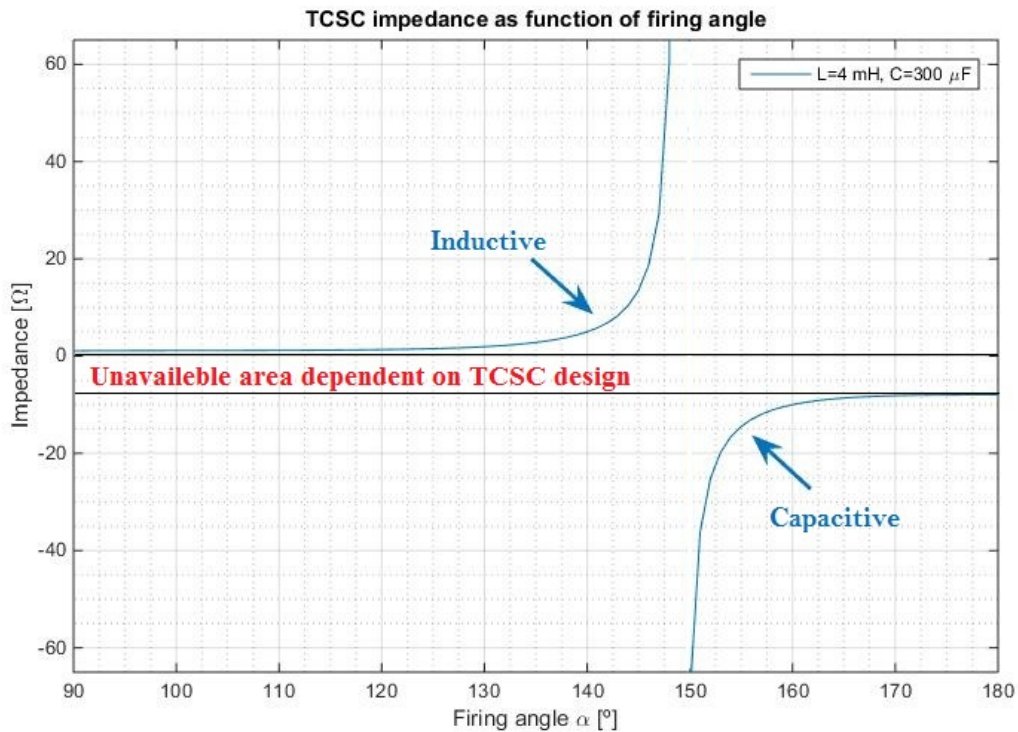

Figure 2.6: Example of TCSC impedance level as a function of firing angle.

and voltages are pure sinusoidal. Of course in a TCSC the currents and voltages are impacted by the controlling thyristors, making them non-sinusoidal [11].

As shown in Figure 2.6, there is always an impedance area in which the TCSC can not operate, this area is important to have in mind when designing the TCSC (choosing sizes of inductor and capacitor).

Figure 2.7 shows TCSC delivered by ABB in opertion in Imperatriz, Brazil.



Figure 2.7: TCSC system delivered by ABB in Imperatriz, Brazil.

### 2.4.4 Design of TCSC

When a TCSC is designed, it is important to choose the right values of the capacitor and inductor. The price and size of the components are the main limitations. The sizes of the components affect each other, and this is important to have in mind when designing the TCSC. There are some important points that must be considered in the design:

1.  $X_C$  must be larger than  $X_L$ . If this requirement is not fulfilled, there will be no resonance point and the TCSC will only operate in the capacitive mode. An example of this is in Figure 2.8d.
2. If  $\frac{X_L}{X_C} < \frac{1}{9}$  there will be more than one resonance point. This limits the operating area of the TCSC.
3. The resonance frequency  $\omega_r = \frac{1}{\sqrt{LC}}$  must be much larger than the power frequency  $\omega_1 = 2\pi f$ . This is so the capacitor voltage can be reversed within a half power period.
4. The resonance frequency  $\omega_r$  must also be far away from the harmonics of the power frequency, ie.  $\omega_r \neq n\omega_1$  where  $n = 1, 2, 3, \dots$
5. It is usually possible to achieve a capacitive reactance of about three times the blocking mode capacitive reactance, before getting to close to resonance point. When choosing capacitor value, this must be considered with respect to the need for compensation, the line reactance, and whether or not there will be fixed capacitors in series in addition to the TCSC.
6. A large inductor gives a lower current through it, and thyristor ratings and cost will be lower. A large inductor is also contributing to smaller harmonics components.
7. With a small inductor, the capacitor voltage reversal will be fast and good, and a small value is also be beneficial if a fault occurs by limiting its size.

For all practical purposes  $\frac{\omega_1}{\omega_r} < \frac{X_L}{X_C}$ , this means that if point 3 is fulfilled, so is point 1. Figure 2.8 shows the impedance range as a function of firing angle for different values of capacitors and inductors arranged with respect to  $\frac{\omega_1}{\omega_r}$  relationships (firing angle of resonance). As explained in the points above, the resonance angle is given by the relationship between the capacitor and inductor. A high inductor value compared to the capacitor can give no resonant points, and a

low can give more than one resonant points. The capacitor value must as explained be chosen with the desired capacitive compensation in mind. A larger capacitor (lower capacitance) gives more capacitive compensation [16]. Other important factors to consider while choosing capacitor and inductor sizes are the voltage and current limits. Both thyristors, inductor and capacitor can not have to high currents through them to prevent damage and overheating, and the insulation level is limiting the voltages. These requirements are of course fulfilled for operating TCSCs

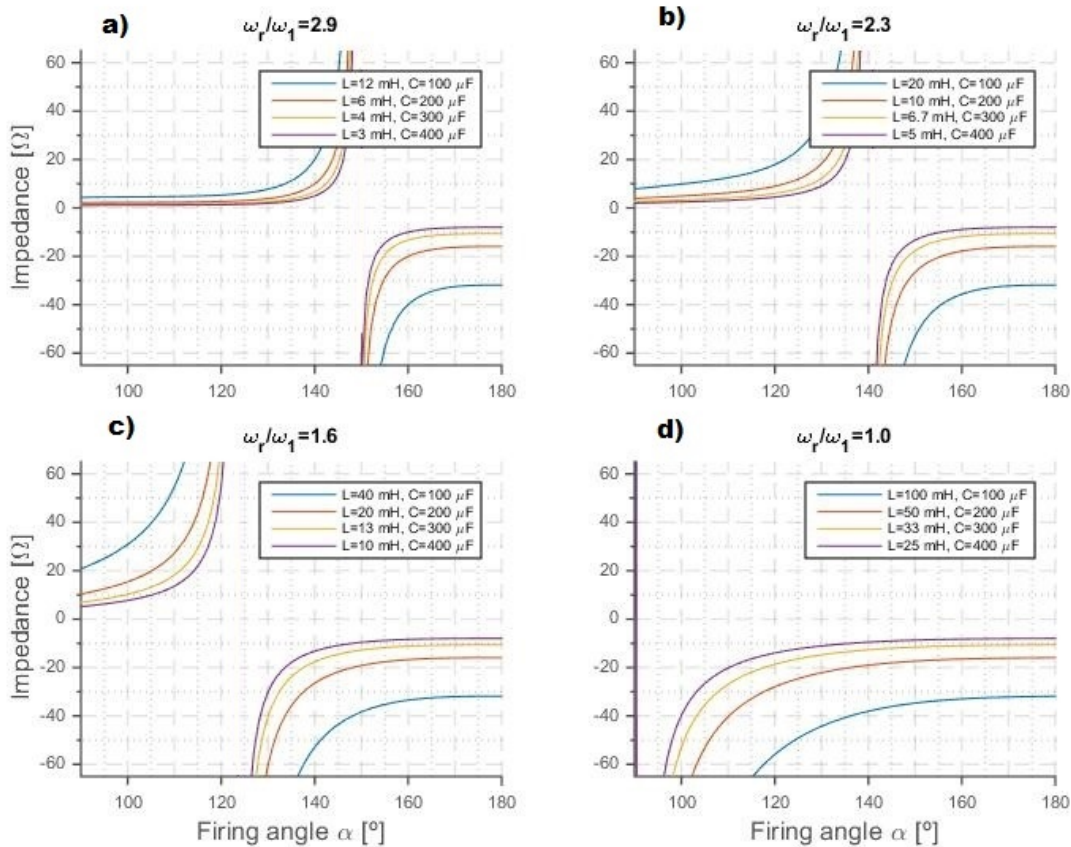

Figure 2.8: Example of TCSC impedance levels as a function of firing angle for different capacitor and inductor values arranged by  $\frac{\omega_r}{\omega_1}$  relationships.

around the world, and some of these can be seen in Table 2.1 [13][17].

Table 2.1: Sizes and ratings of some TCSCs in operation around the world

TCSC	Kayenta ASC	Slatt TCSC	Brazil TCSC
Voltage level [kV]	230	500	550
Rated current [A]	1000	2900	1500
Capacitance [ $\mu$ F]	193	350	200
Inductance [mH]	8.5	3.5	7
$\frac{\omega_1}{\omega_r}$	2.5	2.9	2.7

## 2.5 Subsynchronous Oscillations

In most power system analysis, all parts of the rotor of a turbine generator is assumed to have an infinite stiffness between them. Hence it can be represented as a single mass with one inertia constant. This mass is accountable for all oscillations with other generators in the system at a frequency between 0.2 and 2 Hz, and the single mass method is acceptable in most cases of power system analysis. However, this representation is a large simplification of the turbine generator, especially the steam turbine generator, and can not be used under certain circumstances [18].

The steam turbine generator is composed of several *masses* with different inertia constants, and a finite stiffness and damping between them. In addition to the generator part, there is a high and intermediate pressure part of the rotor, and often there is two masses for the low pressure part. If the generator has an exciter, this too will have a unique mass. This means that when an external force is applied to the masses, they will react differently because of the different inertias. The shafts connecting the masses will twist due to the finite stiffness, and a torque will be transmitted to the neighboring masses. The neighboring mass will the react in the same way, and this will repeat down the shaft, and torotional oscillations occur. Every generator rotor will have unique *torotional natural frequencies* or *modes* dependent on its design. The oscillations can be increased if the network have a certain configuration, or have certain devices implemented. Some of these circumstances will be discussed in greater detail later. The oscillations will reduce the lifetime of the shaft, and in extreme cases lead to shaft failure [19].

To avoid shortened lifetime or failure, it is important to understand these oscillations, when they arise, and how to prevent them.

Figure 2.9 shows a simplified mass representation of parts of a steam turbine generator. Mass 2 and 3 could as an example represent the low and intermediate pressure part of the rotor. Mass 1 which is not included, could be the generator mass.

In Figure 2.9,  $\tau_2$  and  $\tau_3$  are the applied torques. The other drawn torques are the resulting shaft torques.  $\omega_0$  is the angular frequency of the system, while  $\omega_2$  and  $\omega_3$  are the angular frequency of the masses.  $\delta_2$  and  $\delta_3$  are the resulting displacement of the masses.

As an example, mass 2 will be studied. When newtons second law is applied to this mass, the

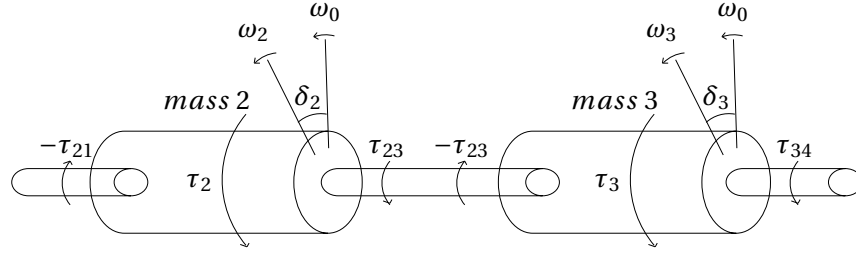

Figure 2.9: Simplified mass representation of parts of a steam turbine rotor

motion equation is given by

$$J_2 \frac{d^2 \delta_2}{dt^2} = \tau_2 - \tau_{21} + \tau_{23} \quad (2.11)$$

where  $J_2$  is the moment of inertia for mass 2,  $\tau_2$  is the applied torque and  $\tau_{21}$   $\tau_{23}$  are the torques in the shafts on each side of mass 2. These torques are given by the damping and stiffness in the shaft between the masses, the difference between the displacement of the them, and the difference between the rate of change in the two masses. In Figure 2.10 the masses and shafts are shown with the belonging inertia, stiffness and damping.

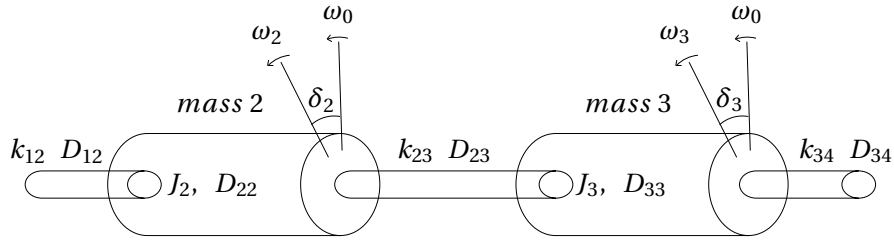

Figure 2.10: Mass representation of parts of a steam turbine rotor with inertia, stiffness and damping constants.

The shaft torques are given by the equations:

$$\tau_{21} = k_{21}(\delta_2 - \delta_1) + D_{21} \left( \frac{d\delta_2}{dt} - \frac{d\delta_1}{dt} \right) \quad (2.12)$$

and

$$\tau_{23} = k_{23}(\delta_3 - \delta_2) + D_{23} \left( \frac{d\delta_3}{dt} - \frac{d\delta_2}{dt} \right) \quad (2.13)$$

When inserting equation (2.12) and (2.13) into equation (2.11), and considering the self damping of mass 2 (the  $D_{22}$  term in the equation), the resulting second order equation becomes:



$$J_2 \frac{d\delta_2^2}{dt^2} = \tau_2 - k_{21}(\delta_2 - \delta_1) - k_{23}(\delta_2 - \delta_3) - D_{21} \left( \frac{d\delta_2}{dt} - \frac{d\delta_1}{dt} \right) - D_{23} \left( \frac{d\delta_2}{dt} - \frac{d\delta_3}{dt} \right) - D_{22} \frac{d\delta_2}{dt} \quad (2.14)$$

If now difference between the system angular frequency and the angular frequency of a mass, for example mass 2 is considered as  $\Delta\omega_2 = \omega_2 - \omega_0$ , there is two state variables per mass in the system. Since  $\Delta\omega_2 = \frac{d\delta_2}{dt}$ , equation (2.14) can be written as the first order equation (2.15)

$$J_2 \frac{d\Delta\omega_2}{dt} = \tau_2 - k_{21}(\delta_2 - \delta_1) - k_{23}(\delta_2 - \delta_3) - D_{21}(\Delta\omega_2 - \Delta\omega_1) - D_{23}(\Delta\omega_2 - \Delta\omega_3) - D_{22}\Delta\omega_2 \quad (2.15)$$

There will be an equation like this for each mass in the system. A representation of a simple four mass system is shown in Figure 2.11. A four mass system like this will have four equations.

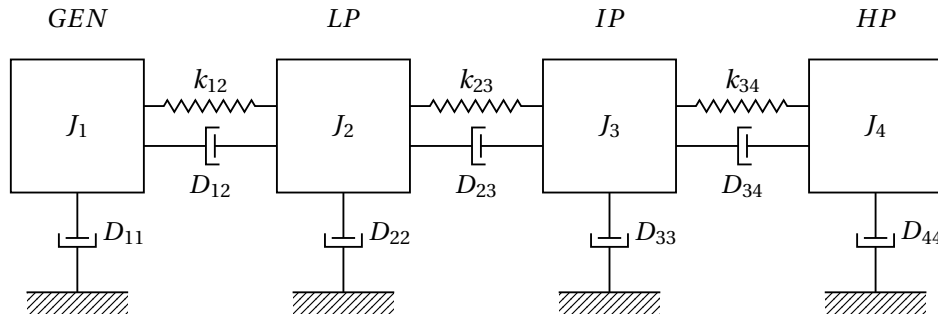

Figure 2.11: Mechanical representation of a four mass turbine generator

By considering the angles and angular frequencies state variables, the equations can be represented by a matrix equation on the form

$$\dot{x} = Ax + Bu \quad (2.16)$$

where  $A$  is the *state matrix*,  $B$  is the *driving matrix*,  $x$  is a *vector of state variables* such as the angles  $\delta$  of equation (2.14) and  $u$  a *vector of inputs*, here the change in torque  $\Delta\tau$  applied to each mass. This equation can be used to find the natural frequencies of the rotor. The state matrix  $A$  is given by

$$A = \begin{bmatrix} 0 & 1 \\ K & D \end{bmatrix} \quad (2.17)$$

where  $0$  is a null matrix,  $1$  is the identity matrix,  $K$  is the stiffness matrix and  $D$  is the damping matrix. For the example system in Figure 2.11 the  $K$  and  $D$  matrix are

$$K = \begin{bmatrix} \frac{-k_{12}}{J_1} & \frac{k_{12}}{J_1} & & & & \\ \frac{k_{12}}{J_2} & \frac{-k_{12}-k_{23}}{J_2} & \frac{-k_{23}}{J_2} & & & \\ & \frac{k_{23}}{J_3} & \frac{-k_{23}-k_{34}}{J_3} & \frac{k_{34}}{J_3} & & \\ & & \frac{k_{34}}{J_4} & \frac{-k_{34}}{J_4} & & \end{bmatrix} \quad (2.18)$$

$$D = \begin{bmatrix} \frac{-D_{12}-D_{11}}{J_1} & \frac{D_{12}}{J_1} & & & & \\ \frac{D_{12}}{J_2} & \frac{-D_{12}-D_{23}-D_{22}}{J_2} & \frac{D_{23}}{J_2} & & & \\ & \frac{D_{23}}{J_3} & \frac{-D_{23}-D_{34}-D_{22}}{J_3} & \frac{D_{34}}{J_3} & & \\ & & \frac{D_{34}}{J_4} & \frac{-D_{34}-D_{44}}{J_4} & & \end{bmatrix} \quad (2.19)$$

The driving matrix B can be written as

$$B = \begin{bmatrix} 0 & J^{-1} \end{bmatrix}^T \quad (2.20)$$

where  $J^{-1}$  for the case in the example is a 4 x 4 matrix where the diagonals are  $1/J_1$ ,  $1/J_2$ ,  $1/J_3$  and  $1/J_4$ .

However, to find the natural frequencies of the rotor, the B matrix is not necessary, because it is calculated by assuming no change in input torque ( $u=0$ ). Using  $u=0$  gives the equation

$$\dot{x} = Ax \quad (2.21)$$

The solution of this equation, gives the eigenvalues and eigenvectors. As an example the modes of IEEE's FBM multimass model are calculated using the data in Table A.7 and computer software. The Modes are presented below in Table 2.2.

Table 2.2: Modes of IEEE FBM six mass model

Mode no.	1	2	3	4	5	6
Frequency [Hz]	14.4	14.4	18.5	23.3	29.5	43.1

Note that the first benchmark model has six masses, that is why there are six modes. If the system in Figure 2.11 would be used, there would be four modes, one for each connection between the masses, and one for the oscillations of the entire rotor.

### 2.5.1 Subsynchronous Resonance

If the *sub-natural frequencies* of the eigenvalues found in previous section ( $f_{sub}$ ) are similar to the *network natural frequency* ( $f_{er}$ ), the oscillations from the generator(s) will be amplified.

$$f_{er} \approx f_{sub} \quad (2.22)$$

and

$$f_{sub} = f_0 - f_{TM} \quad (2.23)$$

where  $f_0$  is network frequency, and  $f_{TM}$  is the torotional frequency found in calculated eigenvalues (*natural frequencies of rotor or torotional modes of oscillation*).

These frequencies can now be used to find the compensation level of the line that will get SSR. If the equations (2.22) and (2.23) is solved for  $f_{TM}$  they become

$$f_{TM} \approx f_0 - f_{er} \quad (2.24)$$

where

$$f_{er} = f_0 \sqrt{\frac{X_C}{X'' + X_T + X_L}} \quad (2.25)$$

$X_C$  is the reactance of the compensating capacitor, and  $X''$ ,  $X_T$  and  $X_L$  are the subtransient reactance of the generator, the reactance of the transformer, and the line reactance.

The torotional frequencies are very weakly coupled with the overall system, so when system impedance (*network natural frequency*) is changed, these frequencies stay the same. SSR occurs when the sub natural frequency is close to one or more shaft frequencies.

Since the mode frequencies of the rotor can not be changed, and the network natural frequency is changed with compensation, this is where both the problem and some of the solution in this thesis arise (problem when only using fixed compensation, and solution when implementing TCSC).

As researchers have proposed, the TCSC does not mitigate SSR only by changing the impedance. If a TCSC is placed in the system with constant impedance, it can mitigate SSR by adding more electrical damping with effective control and firing [20][21][22][23].

# Chapter 3

## System modeling and results

*This chapter shows the procedure and modeling of the power systems used in this project work. It describes, and gives a visual understanding of the systems studied and presents the results obtained from the studies.*

In the table below, the different study cases in this report are summarized. Abbreviations used are explained further down.

Table 3.1: Summary of study cases in thesis

Case	Fixed Compensation	Multimass	TCSC	Event	Double lines
1	VAR	NO	NO	NO	NO
2	VAR	YES	NO	NO	NO
3	VAR	YES	OL	NO	NO
4	YES	YES	OL/CL	NO	NO
5	YES	YES	OL/CL	NO	YES
6	YES	YES	OL/CL	$Q_{OUT}$	YES
7	YES	YES	OL/CL	$P_{OUT}$	YES

VAR = Several simulations are done with variable fixed compensation.

OL = Simulation(s) are done with TCSC, and controller in open loop.

OL/CL = Simulation(s) are done with TCSC, and controller in both open and closed loop, often starting with open, then switching to closed loop after a period of time.

$Q_{OUT}$  = Event with consumed reactive power outage.

$P_{OUT}$  = Event with active load outage.

### 3.1 Case 1: Model of Power System

The first step in this work is to model the power network. The model is a simplification of the Great Britain power system, and consists of four buses with three generators and two loads. The data for the generators are found in [2], the load, line and transformer data are found in [3].

Most of the base model for these simulations were made in the project work prior to this master thesis, now, more details are implemented. The model is built in the program PSCAD which is a tool for describing electromagnetic transients.

Figure 3.1 shows the modeled system equivalent circuit, and its data is summarized in Table 3.2. The system consists of four buses where the upper buses represent the north and south of Scotland, where there is a surplus of power due to large power production. The lower bus is representing England and Wales, where there is a deficit of power due to high consumption. Between the areas there are transmission lines where the power is flowing.

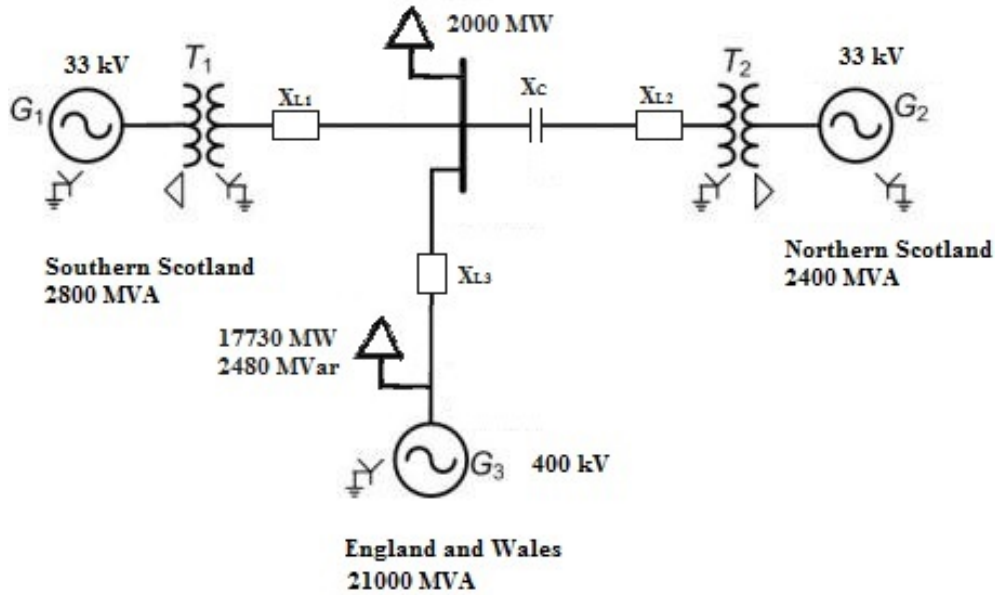

Figure 3.1: Great Britain power system model

Due to the fact that there is a large surplus in the north of Great Britain, and a deficit in the south (in addition to the potential for more renewable energy production in the north), there is a great need for power transfer from the north to the south.

A logical step to increase the power flowing from north to south as seen in section 2.2, is implementing series compensation as shown in Figure 3.1.

Several simulations are done, and Figure 3.2 shows the power flowing in the Northern Scotland line as a function of the degree of compensation of the system. The degree of compensation

Table 3.2: Great Britain power system model parameters

	Size	Voltage	Note
$G_1$	2800 MVA	33 kV	Star grounded
$G_2$	2400 MVA	33 kV	Star grounded
$G_3$	21000 MVA	400 kV	Star grounded
$T_1$	2800 MVA, $j22.4 \Omega$	33/400 kV	Delta/Star connected
$T_2$	2400 MVA, $j11.2 \Omega$	33/400 kV	Delta/Star connected
$Line_{14}$	$0.001+j3.1 \Omega$	400 kV	
$Line_{24}$	$0.001+j31.4 \Omega$	400 kV	Uncompensated
$Line_{34}$	$0.001+j15.6 \Omega$	400 kV	
$Load_3$	17730 MW + 2485 MVar	400 kV	
$Load_4$	2000 MW	400 kV	

of the line is defined by

$$\% \text{ comp} = \frac{X_C}{X_{Ltot}} \quad (3.1)$$

where  $X_C$  is the reactance of the fixed capacitor and  $X_{Ltot}$  is the total reactance of the system seen from the generator in Northern Scotland (without the compensation).

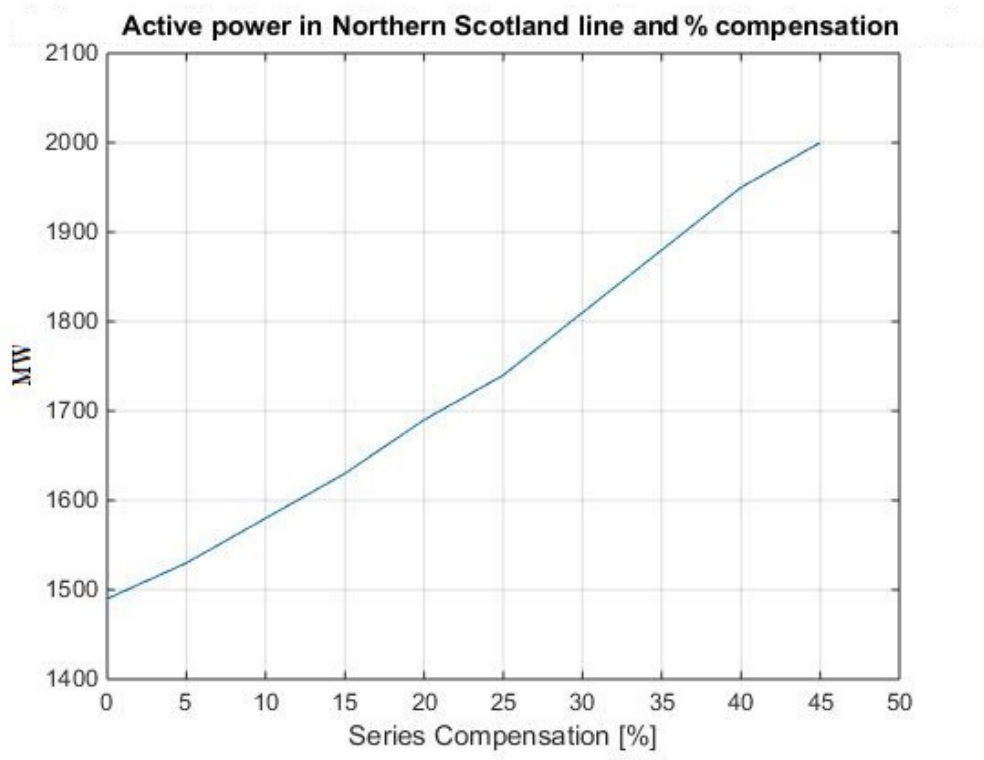

Figure 3.2: Active power flow in Northern Scotland line as a function of % compensation.

As Figure 3.2 clearly shows, the power flowing in the line is increasing with increasing degree of fixed compensation. This is expected according to section 2.2.

However, a large fixed series compensation can not be done without consideration regarding natural network frequency and resonance. The fact that the electrical resonance frequency of the system will change like described in section 2.5 will eventually lead to SSR if the compensation reaches a certain degree.

### 3.2 Case 2: Implementing Multimass and increasing Fixed Compensation

For a study of the subsynchronous resonance in the system to be possible, the PSCAD model needs some further implementations. To simulate a steam turbine rotor, a "multimass" model is implemented in the Northern Scotland generator. Values for inertia are assigned to each mass, as well as damping and stiffness between the masses, as described in section 2.5. The number of masses, and data which is used, are the same as in the IEEE first benchmark model on subsynchronous resonance. The data is found in [3], and is displayed in Table 3.3. The first benchmark model is a six mass model, like shown in Figure 3.3.

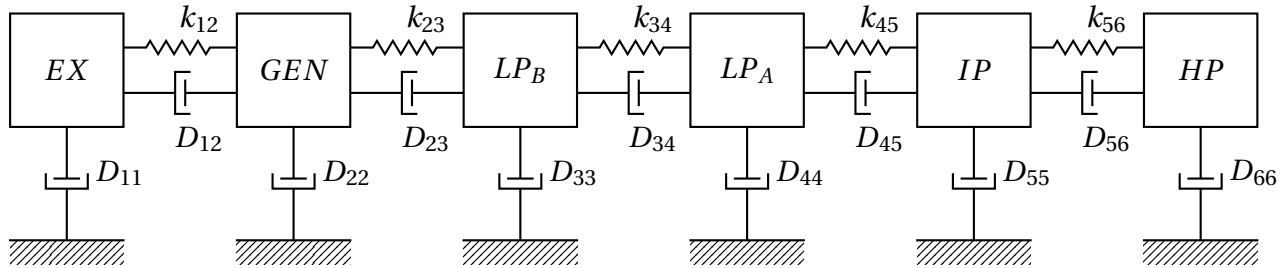

Figure 3.3: Mechanical representation of IEEE FBM model for SSR.

Table 3.3: Inertias, Torotional stiffness, self and mutual damping coefficients of IEEE FBM model for SSR.

Inertia	$[\frac{MWS}{MVA}]$	Stiffness	$[\frac{pu T}{rad}]$	Self- and mut. damping	$[\frac{pu T}{pu Speed dev.}]$
$H_{HP}$	0.092897	$k_{12}$	19.303	$D_{11}, D_{22}$	0
$H_{IP}$	0.155589	$k_{23}$	34.929	$D_{33}, D_{44}, D_{55}, D_{66}$	0.1
$H_{LPA}$	0.858670	$k_{34}$	52.038	$D_{12}$	0.005
$H_{LPB}$	0.884215	$k_{45}$	70.858	$D_{23}, D_{34}, D_{45}, D_{56}$	0.2
$H_{GEN}$	0.868495	$k_{56}$	2.822		
$H_{EX}$	0.0342165				

Now with the first benchmark model implemented, the fixed compensation can be increased, and realistic results is expected considering SSR. From simulations, Figure 3.4 is produced. It shows the electrical frequency of the system at different levels of compensation, ie. when the line is compensated to 40 % or 48 % etc.



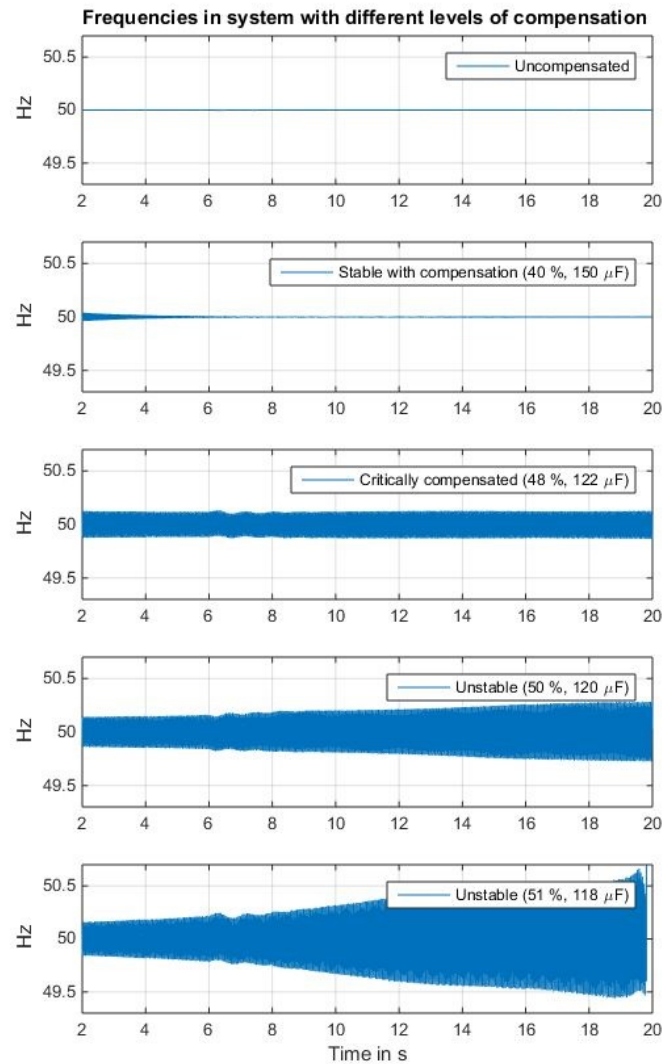

Figure 3.4: Electrical frequency in the system at different levels of % compensation.

Figure 3.4 shows that the system has low frequency variations (SSR) at compensation levels below 48 % compensation, but can not be compensated more than to 48 %, before it gets unstable due to the SSR. A higher compensation after this point, means a faster crash of the system, as all other compensation levels above 48 % is unstable. This means that the sub-natural frequency of the system is too close to one or more of the rotors natural modes of oscillation at these levels.

When Figure 3.4 and 3.2 is studied, the results show that to be able to transfer more power (in this case more than about 2 GW) in the Northern Scotland line, measures have to be taken. Implementing a TCSC in the network might be a solution.

### 3.3 Case 3: Implementing TCSC

To test if it is possible to increase the compensation and hence the power flow even further than with the fixed compensation, a TCSC ( $L = 5\text{mH}$ ,  $C = 400\mu\text{F}$ ) is designed and implemented in the system in series with the fixed capacitor. The design is done in accordance with the theory of section 2.4.4, and it is a relatively small TCSC. The system is shown in Figure 3.5.

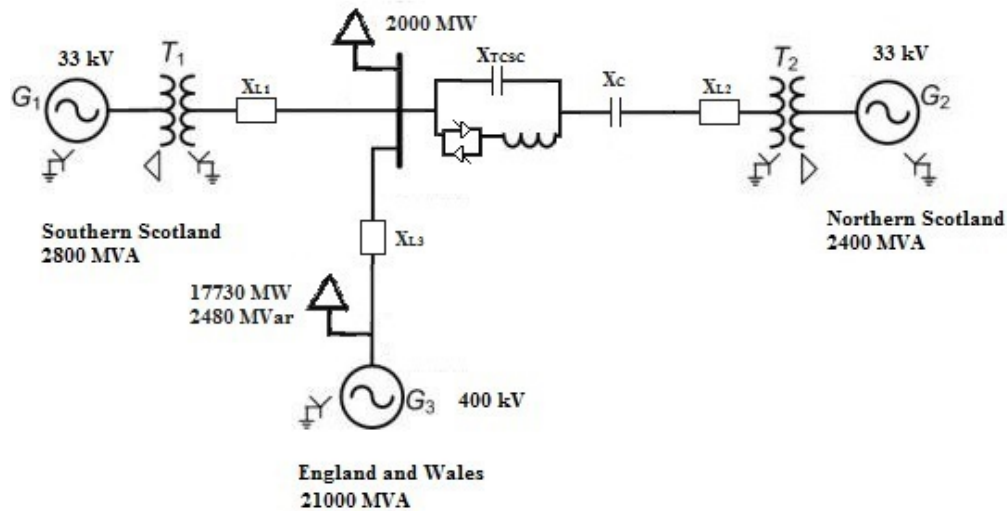

Figure 3.5: Model of power system with both fixed compensation and TCSC.

Figure 3.6 shows the case with only the fixed compensation at the critical level 48 %, and the case where the TCSC is implemented in addition. The TCSC firing angle and the size of the fixed capacitor is set to values that will make the total compensation of the hybrid system also equal to 48 %.

From Figure 3.6 it is clear that, at least in the case where the compensation level is 48 %, there is a significant improvement by using the hybrid fixed compensation and TCSC system. This is due to an added damping from the TCSC.

To further investigate if the hybrid system is making it possible to increase the compensation degree even more, the firing angle of the TCSC and the size of the fixed capacitor is varied, and simulations are done. Note that in all of the test cases, the TCSCs controller is in open loop (constant firing angle), this means that the TCSC is having a fixed reactance.

Figure 3.7 shows the power flow in the Northern Scotland line, as a function of % of compensation both for the fixed capacitor, and the hybrid capacitor and TCSC case. The TCSC firing

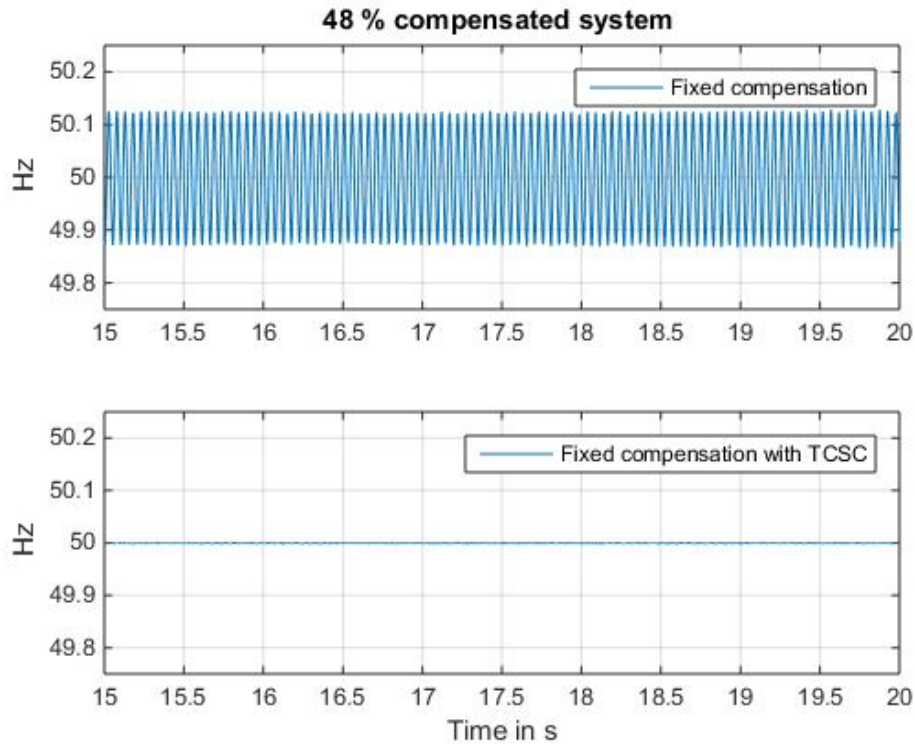

Figure 3.6: Electrical frequency in the two simulated systems with equal degree of compensation.

angle and the size of the fixed capacitor is varied to show different compensation levels. All plotted cases are stable, and have a relatively low frequency variation.

The results making up Figure 3.7 shows that a TCSC, even a small one, can improve the power flow of this system with 500 MW compared to a fixed capacitor, and around 1 GW compared with no compensation.

In these cases, the TCSC is set to have a firing angle so that it is operating in inductive mode, as described in section 2.4. Here the fixed capacitor and the TCSC will have opposite signs of the reactance (the much larger fixed compensation is used to compensate, and the TCSC has the function of varying the reactance).

In many scenarios if there is not already fixed compensation in the system, one would naturally insert a larger TCSC and run it in the capacitive mode. In theory this is no problem compared with the hybrid solution and one could expect the same results. However, with the model of the power system and TCSC firing system there is simulation problems. Some successful simulations have been done with the TCSC in capacitive mode, but the compensation level is not close to the obtained 75 % by the hybrid system.

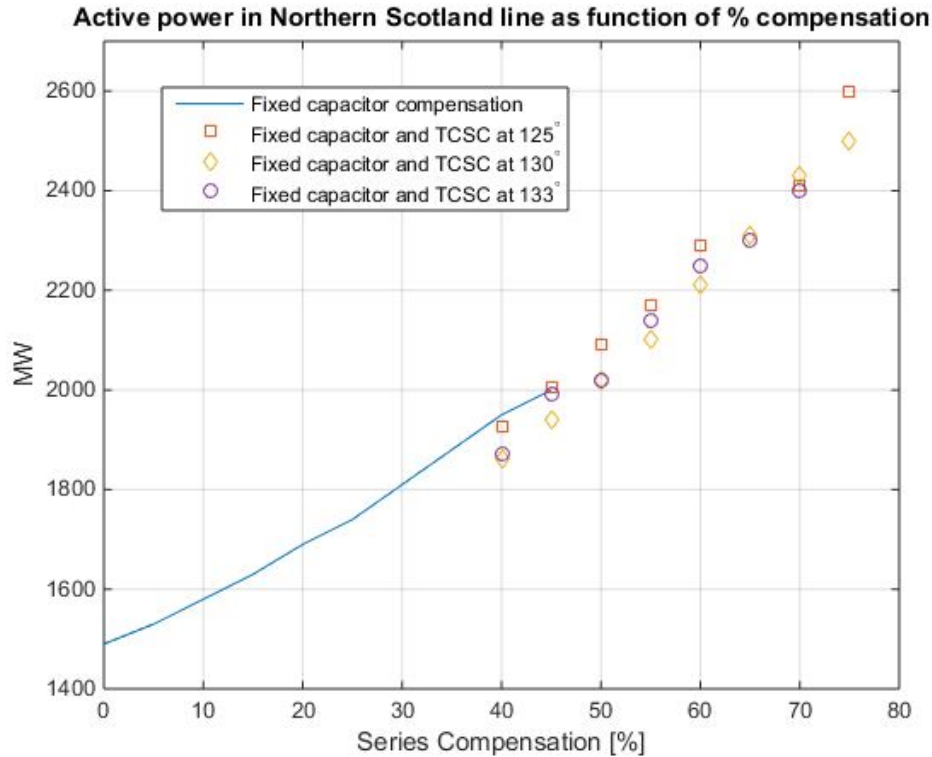

Figure 3.7: Active power flow in Northern Scotland line as a function of % compensation with both fixed compensation and fixed combined with TCSC.

As mentioned there is many scenarios were there is a need to vary or change the impedance of the line. This can be done with a closed loop controller. The controller could have references such as current, power or impedance. The reference values can be adjusted when needed.

### 3.4 Case 4: TCSC with Controller in Closed loop

To further study the effect on SSR when impedance is changed, a closed loop controller is implemented in the TCSC. The controller is show in Figure 3.8 [14].

A simulation is done where the fixed capacitor is  $80\mu F$  and the TCSC is starting in open loop at  $100^\circ$ . After 15 seconds the controller goes from open to closed loop with a power flowing in the Northern Scotland line as a reference.

Figure 3.9 show the frequency of the system, and the firing angle of the controller.

When the controller firing angle increases from 100 degrees, the inductive impedance increases like shown in Figure 2.6. The firing angle of the TCSC goes from  $100^\circ$  to  $130^\circ$  and gives



### 3.5 Case 5: Modeling of System with double lines from Northern Scotland

To have a more accurate representation of the Great Britain power network, a double line is implemented in Northern Scotland.

If the fixed capacitor and the TCSC now is placed in one of the lines as shown in Figure 3.10, there is no problems with SSR in any of the simulations. The line can now be compensated all the way to the degree where all power is flowing in the one line.

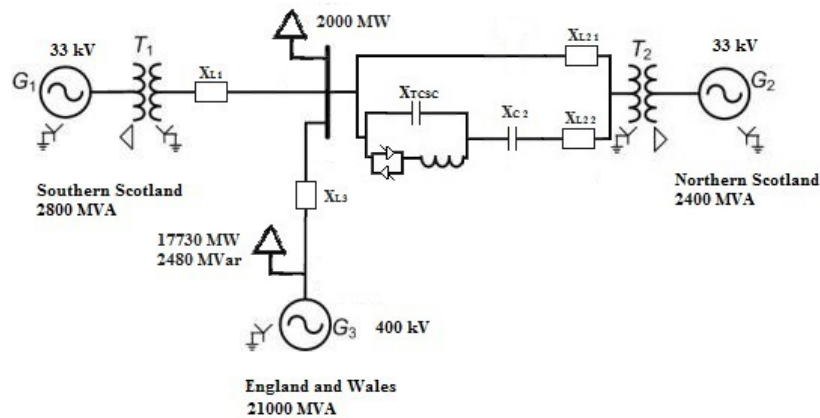

Figure 3.10: Power system model with double lines, fixed compensation and TCSC in one of the lines.

With the double lines, the TCSC can also operate in the capacitive mode without stimulation crashing. Several TCSC sizes are tested. However, there are some uncertainty with these cases, and not all results are as expected, therefore no plots are used in the report.

Now one small fixed capacitor is placed in each line (the compensation level is so small that SSR is not an issue). The TCSC is placed in one of the lines, and a closed loop power controller is initialized after 15 seconds. The network is shown in Figure 3.11.

The results of the simulation is shown in Figure 3.12. Here it is clear that the power is reaching the desired level after approximately six seconds of closed loop operation. This means that the design of the TCSC controller is satisfactory. There is however some oscillations in the power in this case.

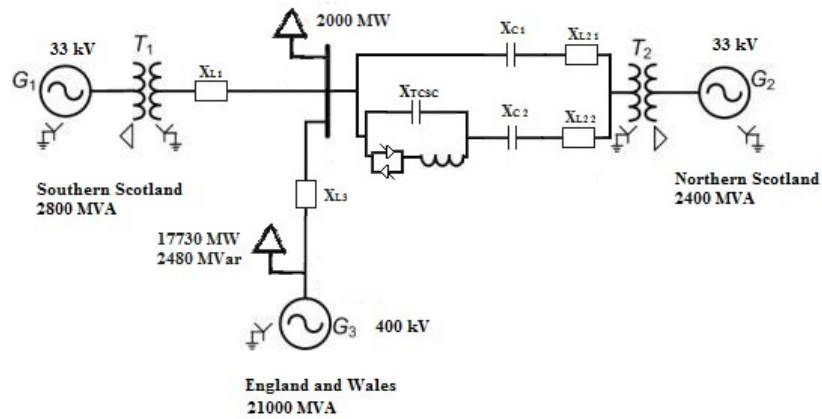

Figure 3.11: Power system model with double lines, fixed compensation in both and TCSC in one line.

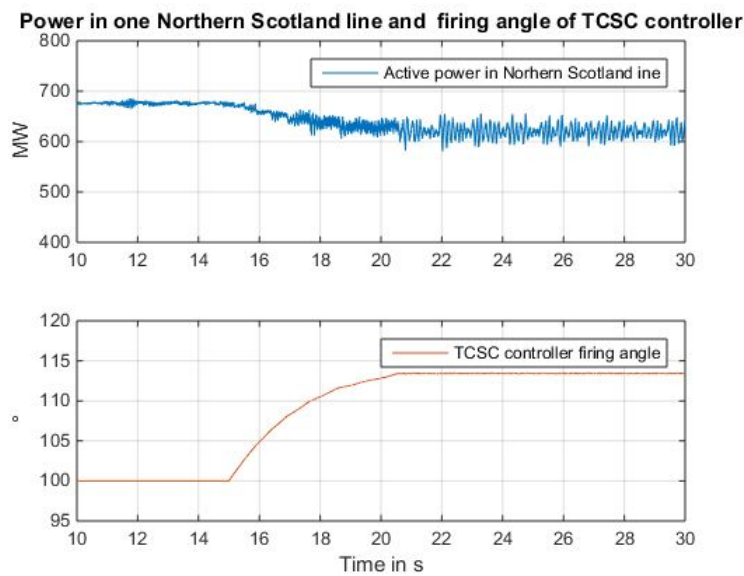

Figure 3.12: Electrical frequency response when active power is controlled in one of the two parallel lines.

### 3.6 Case 6: Reactive Power Event

To further show the value of the TCSC and have a more realistic network, the fixed compensation the lines are increased. Now the system is more vulnerable to contingencies regarding SSR. As a possible event, an 2400 MVar capacitive load is inserted at the load bus in the north. Inserting produced capacitive reactive power is the same as removing consumed reactive power from the system. This can be relevant if for instant a inductive compensating reactor is isolated from the network due to fault, or a large load at the end of a sea cable is suddenly disconnected. Figure 3.13 shows the setup for this case study.

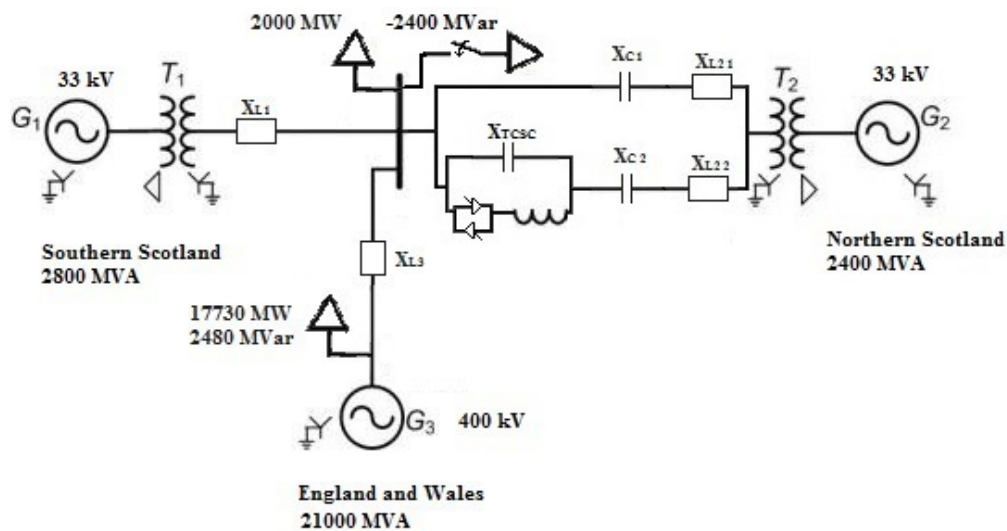

Figure 3.13: System with both fixed compensation and TCSC. Reactive power event.

This event is run with two scenarios:

- one where the TCSC is run in open loop, (100 °).
- one where the TCSC is switched from open (100 °) to closed loop (increasing from 100 °) 0.5 seconds after the event occurs. This is to change the total compensation level of the system.

Figure 3.14 shows the electrical frequency in the systems in both cases, and firing angle of the TCSC controller in the closed loop case.

From figure 3.14 it is clear that the system becomes unstable after the event if impedance is not changed. From the frequency plot, one can clearly see SSR appearing in the open loop case.



Not many seconds after the event, the system crashes.

However, when the controller of the TCSC is set to closed loop 0.5 seconds after the event, the system stabilizes after few seconds. The reference of the controller is set so that the inductive impedance of the TCSC will increase.

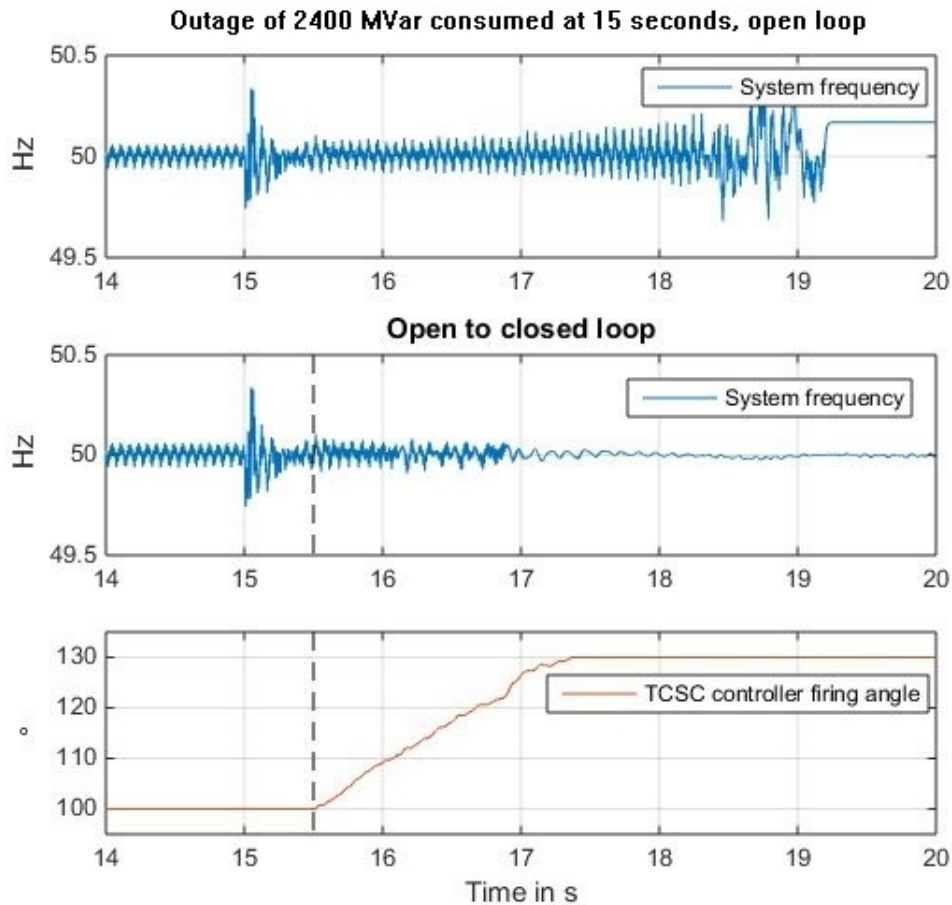

Figure 3.14: Electrical frequency response to reactive power event. Open and closed loop including firing angle.

Note that the TCSC will most likely be operated in closed loop at all times in real life, but here it is shown in open loop to begin with to better see the possibilities and uniqueness of the TCSC. This also shows how a system with fixed compensation (even with the damping of the TCSC) is more vulnerable to SSR than a system with variable compensation.

### 3.7 Case 7: Power Outage Event

Another event is simulated in the same system as described earlier. Now instead of a change in reactive power, a load of 1200 MW is disconnected from the load bus in the north. The system with the event is seen in Figure 3.15. Note that 1200 MW is removed from the original load in the north, leaving it with a size of 800 MW.

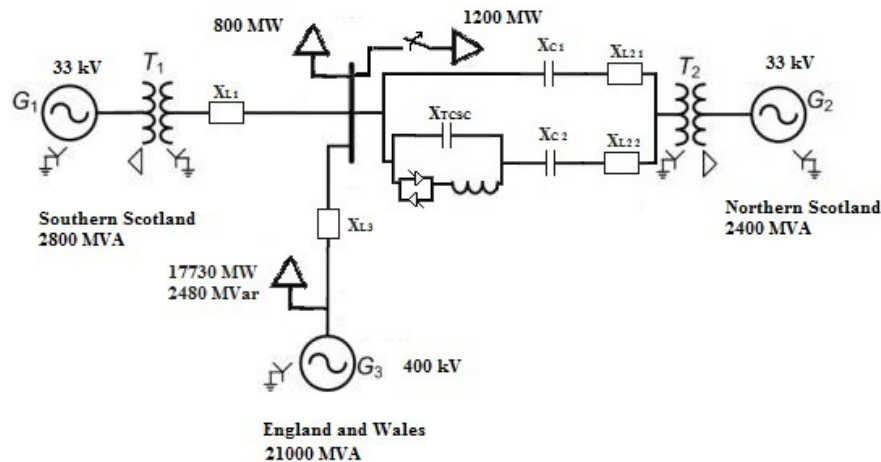

Figure 3.15: System with both fixed compensation and TCSC. Loss of active power event.

The outage event will decrease the current flowing in the system, and making the consumed reactive power decrease. The produced reactive power will mostly stay the same due to the relatively constant voltage in the lines.

In this case as well as in the previous, two scenarios are simulated; one with constant impedance (open loop), and one with increasing impedance (closed loop).

Figure 3.16 shows again that the case with the constant impedance is having an increasing frequency variation due to SSR and eventually crash. For the closed loop case the frequency settles at almost the same levels as before the event.

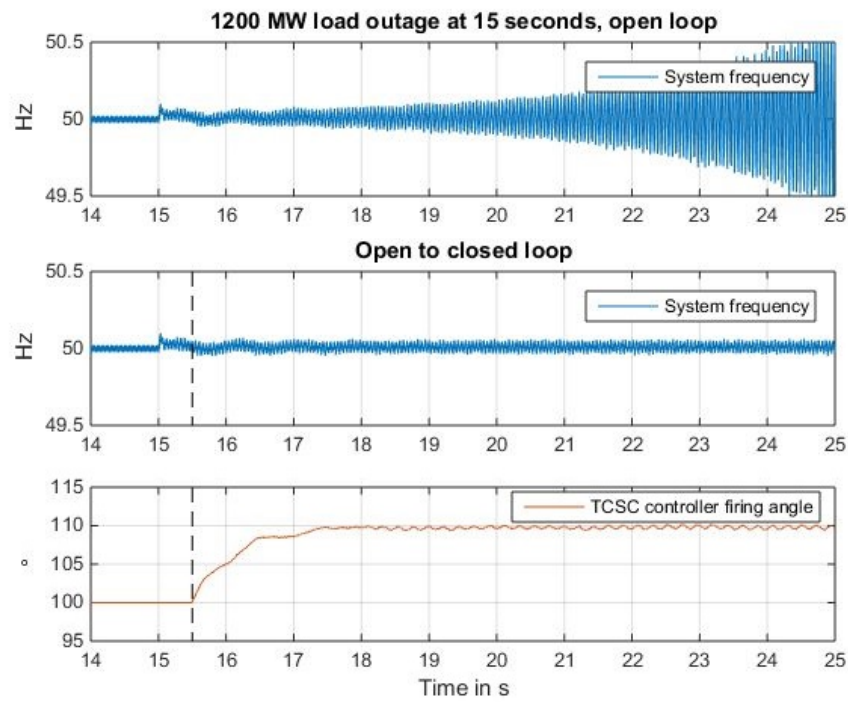

Figure 3.16: Electrical frequency response to active power outage event. Open and closed loop including firing angle.

# Chapter 4

## Summary and Further Work

*This chapter is a summary chapter with a discussion and a conclusion section. Lastly there is a section containing some recommendations for future work.*

## 4.1 Discussion

Subsynchronous resonance have been the main field of study in this thesis. The Great Britain transmission network have been used as a study case. The model of the Great Britain network is simplified, but all the data used for the model is found in several prestigious articles.

As explained in the introduction, compensation is necessary in this network due to the need for efficient power transfer from North to South of the island. This is described in the theory of section 2.2. In section 3.1, this theory is proved by simulating several different study cases with variable compensation. When the power flow from the North to the South is increasing with increasing compensation, the results are validating both the theory, and the model of the Great Britain power network.

In section 3.1, no SSR is occurring at any level of compensation. This is due to the fact that the system is not sufficiently detailed yet. A multimass model is implemented to have a more detailed model. IEEE's first benchmark model on SSR is used. All power systems consists of several smaller generators all with different design, but here one model is used for simplicity. This seems to be the norm in other SSR studies as well. The IEEE model is of course made to simulate real generators, so in this regard the result will still be valid.

When the multimass is implemented in the system, the results of section 3.2 shows that the expected SSR is "successfully" produced when compensation reaches a certain degree. When the IEEE FBM is previously used in other studies, SSR have occurred with similar degrees of compensation. This validates that the multimass model is correctly implemented, and that the calculations done on compensation levels are reliable. As seen in section 3.2 it seems that a higher compensation, leads to a more unstable system. This is however not necessarily true, as the system could in theory be stable at compensation levels making the sub-*natural network frequency* far enough away from (between two) *natural frequencies of rotor* as described in section 2.5.1. A clearer picture of this would be provided with more time and resources. A procedure for presenting it would be to manually calculate the eigenvalues of the system at different levels of compensation and plotting the results as done in [3].

To study the effect of the TCSC, it is implemented in the compensated line. The design of the TCSC is done according to the theory of section 2.4.4 and to get a satisfactory range of com-

pendensation. According to theory, the range of the possible reactance values of the TCSC will be enough to both affect power flow and *natural network frequency* if needed.

From Figure 3.6, where two system electrical frequencies are plotted with the same degree of compensation, one having the TCSC implemented, it can be seen that implementing a TCSC is clearly damping the oscillations. This means that the TCSC is mitigating SSR independent of compensation level ie. damping oscillations by just being in the system.

The TCSC is adding a damping to the system, and Figure 3.7 is showing that this makes it possible to compensate further than 50 % without SSR occurring. The results show that with a TCSC, there is many scenarios where more power can be transferred than without. However, when studying this case, it became clear that not all compensation levels and combination of TCSC with firing angle and fixed capacitor is stable. Some combinations did not end with a successful power flow. Here it would have been interesting to have done the eigenvalue studies mentioned previously. From this study, the power flow from the north of Scotland can be improved with more than 25 % by implementing a TCSC. From this it is clear that to increase power flow, the TCSC is a highly attractive choice for this network compared to construction of new lines.

In section 3.4 the usefulness of controlling the firing angle is studied. A system with initially large compensation is having a TCSC implemented with it changing from a small inductive state to a more inductive state. Initially there are relatively large oscillations in the electrical frequency, but when the firing angle and hence reactance of the TCSC changes, these oscillations are reduced with a magnitude of approximately ten. The results of Figure 3.9 shows that by changing the reactance and the sub-*network natural frequency* moving it away from the mechanical torotional frequencies is important if SSR is to be avoided. These results are confirming the theory of section 2.5.1, and showing that TCSC is able to change the *network natural frequency*.

The double lines from the north of Scotland in section 3.5 is implemented to have a more accurate model of the real Great Britain network. Simulations done until this point are still valid in showing the SSR and the value of the TCSC in a general sense, as two smaller identical lines with double the reactance of the original line would not have an impact on the results. One concern would be that it might not be economically the best decision to have two smaller TCSCs

the two lines. A more reasonable case is to have fixed compensation in one line, and a TCSC (and in this thesis fixed compensation) in the other.

To further study the effect of the TCSC, some specific cases are simulated. The first is one where consumed reactive power is removed from the network. As discussed in section 3.6, this could happen if a reactive load or line is disconnected from the network, or a load at the end of a sea cable being disconnected making the cable consume less reactive power. As reactive power is significant to the *network natural frequency* this change was expected to have an impact on the system, and produce SSR. Figure 3.14 shows that without variable compensation, SSR is occurring and system will eventually crash, while in the case with the TCSC in closed loop the electrical frequency settles quickly. This implies that initially the sub-*network natural frequency* was close to a torsional mode, and that the effect of contingency made the system enter instability.

In section 3.7 another contingency is occurring. Here much of the same is happening as less load leads to a change in the reactive power consumed by the system. The TCSCs ability to change its reactance is shown to be very valuable in these kind of contingency events, and having a TCSC would make the network much more robust.

It is important to note that there is simulated many cases with several different settings on parameters in this thesis. Only a few is presented in the report. Not all contingency events or compensation levels will lead to SSR and one must note that the events plotted are selected due to the SSR occurrence and mitigation. However these events are very likely to happen in a power system and although they not have a high probability, power systems must be designed to have high reliability.

Although this thesis is focused on the Great Britain power network, much of the results can be generalized and applied to other power networks with need of large power transfers over long distances. As SSR inevitably becomes a problem with some level of compensation, the TCSC would be of use in many power network whose need for greater power transfer is present.

## 4.2 Conclusion

The work of the thesis started with a continuation of a project work. A model of the Great Britain power network was developed further and with greater detail from previous project. The power flow and other variables were monitored and the model was continuously validated. It was early shown that with a higher degree of series compensation comes a higher power flow. This was expected and used as a validation of theory and model.

In the beginning of the project, the SSR was not a problem in simulations. The reason was that the model did not have sufficient details. Therefore a multimass model was successfully implemented in one of the generators of the model. Now in section 3.2, more in line with the theory on highly compensated systems, SSR was occurring. The SSR limited the series compensation of the system close to the limits of similar studies on the subject.

After designing a TCSC, simulations were run with both the TCSC and fixed compensation in the system. These simulations were compared to simulations with only fixed compensation with equal degree of compensation. In section 3.3 it is clear that the TCSC is adding damping to the system, and it is successfully shown that it mitigates SSR. From this section it is also shown that with a TCSC the Great Britain network can have nearly twice the compensation level compared with only fixed compensation.

The connection between the control of the TCSC and the occurrence of SSR is presented in section 3.4. In the example presented, the ability to control the TCSC reactance is proven to be of great importance when mitigating oscillations.

When the other TCSCs were designed and implemented to fully replace the fixed compensation of the system, the simulations did not behave as expected and often crashed. Therefore if the objective was to fully replace the fixed compensation with the TCSC, there would be needed more work on that specific case. It can be hinted that the SSR mitigating ability of one large TCSC is as good or better than a combination of fixed compensation and a smaller TCSC, but in this system research is needed to assertively conclude.

After some more detailing of the network model, there were done some specific case studies in section 3.6 and 3.7. Here the TCSCs ability to mitigate SSR occurring from contingencies was proved.



From this thesis it can be stated that the TCSC would be a good option for increased power transfer in the Great Britain power network, and other networks with similar power transfer challenges regarding SSR. Other benefits that come with the TCSC is the ability to control power flow, both under normal operation and during contingencies.

### **4.3 Further Work**

As mentioned earlier, some further work would be to study the TCSC as a full replacement for the fixed compensation in the network. This is very relevant as both all the compensation and SSR mitigation can be done with one unit.

Calculations of eigenvalues in the system with different degrees of compensation both fixed and TCSC would also be an interesting addition to this thesis. This would give a clearer picture of the limitations and improvements of the network regarding stability. It would also be helpful when studying contingencies in the system.

Lastly the interaction between the TCSC and other FACTS or HVDC-terminals could be an interesting field to study as a continuation of this thesis. This will be increasingly relevant in the future, as quickly emerging renewables and technology improvements will increase the use of FACTS/HVDC all over the world.

# Bibliography

- [1] W. Long and S. Nilsson, "Hvdc transmission: Today and yesterday," *IEEE power & energy magazine*, 2007.
- [2] F. M. Hughes, O. Anaya-Lara, N. Jenkins, and G. Strbac, "Control of dfig-based wind generation for power network support," *IEEE TRANSACTIONS ON POWER SYSTEMS*, 2005.
- [3] C. E. Ugalde-Loo, J. B. Ekanayake, and N. Jenkins, "Subsynchronous resonance in a series-compensated great britain transmission network," *IET Generation, Transmission & Distribution*, 2012.
- [4] *Standard Handbook for Electrical Engineers*. Mc Graw Hill, 16 ed., 2013.
- [5] J. J. Grainger and J. W. D. Stevenson, *Power System Analysis*. McGraw-Hill Education, 1994.
- [6] N. Mohan, *Electric Power Systems: A First Course*. Wiley, 2012.
- [7] T. Miller, *Reactive Power Control in Electric Systems*. Wiley, 1982.
- [8] J. Dixon and J. Rodriguez, "Reactive power compensation technologies: State-of-the-art review," *Proceedings of the IEEE*, 2005.
- [9] I. Kiran and J. Laxmi.A., "Shunt versus series compensation in the improvement of power system performance.," *INTERNATIONAL JOURNAL OF APPLIED ENG. RESEARCH*, 2010.
- [10] F. Illiceto and E. Cinieri, "Comparative analysis of series and shunt compensation schemes for ac transmission systems.," *IEEE*, 1977.
- [11] R. M. Mathur and R. K. Varma, *Thyristor-based FACTS controllers for electrical transmission systems*. Wiley, 2002.

- [12] R. M. Malizewski, B. M. Pasternack, and L. Paulson, "Power flow control in a highly integrated transmission network," *CIGRE Paper 37-303*, 1990.
- [13] N. G. Hingorani and L. Gyugyi, *Understanding Facts*. Wiley, 1999.
- [14] O. Anaya-Lara, E. Acha, V. G. Agelidis, and T. Miller, *Power Electronic control in Electrical Systems*. Newnes Power Engineering Series, 2002.
- [15] M. N. Moschakis, E. A. Leonidaki, and N. Hatziaargyriou, "Considerations for the application of thyristor controlled series capacitors to radial power distribution circuits," *IEEE*, 2003.
- [16] M. Nayeripour and M. M. Mansouri, "Analyze of real switching angle limits in tcsc on capacitor and inductor values and their selection factors," *International Journal of Advanced Science and Technology*, 2013.
- [17] C. Gama, L. Angquist, G. Ingestrom, and M. Noroozian, "Commissioning and operative experience of tcsc for damping power oscillation in the brazilian north-south interconnection," *Cigre*, 2000.
- [18] P. Kundur, *Power System Stability and Control*. McGraw-Hill, 1994.
- [19] J. Machowski, J. W. Bialek, and J. R. Bumby, *Power System Dynamics, Stability and Control*. Wiley, 2012.
- [20] V. Zhu, R. Spee, R. Mohler, G. Alexander, W. Mittelstadt, and D. Maratukulam, "An empty study of ssr mitigation using the thyristor controlled series capacitor," *IEEE Transaction on Power Delivery*, 1995.
- [21] N. Kakimoto, A. Iida, M. Seki, K. Minoyama, and T. Takuma, "Clarification of the ssr mitigation mechanism of a tcsc," *Electrical Engineering in Japan*, 1997.
- [22] C. Z. Qianjin Liu and, L. Angquist, and S. Rudin, "Using tcsc scheme for ssr mitigation in a radial transfer corridor," *International Conference on Power System Technology*, 2006.
- [23] R. Zheng, G. Li, and J. Liang, "Capability of tcsc on ssr mitigation," *Journal of Power and Energy Engineering*, 2015.

# **Appendix A**

## **Great Britain Power System Information**

The system is a four bus system. Generator 1 is at bus 1, generator 2 at bus 2 and generator 3 at bus 3. Bus 4 is the connection point for all the other buses, and the north load lies at this bus.

## A.1 Lines

Table A.1: Line data

Line	Impedance [ $\Omega$ ]
1-4	0.001+j3.4
2-4	0.001+j31.4
3-4	0.001+j15.7

## A.2 Loads

Table A.2: Load data

Bus	[MW]/ph	[MVar]/ph	Ref. voltage (l-g) [kV]
3	5910	828	144.4
4	667	0	144.4

## A.3 Transformers

Table A.3: Transformer data

	Transformer 1	Transformer 2
Rating [MVA]	2800	2400
Configuration	$\Delta/Y$ ( $\Delta$ lags Y)	$\Delta/Y$ ( $\Delta$ lags Y)
Voltage ratio	33/400	33/400
Leakage reactance [ $\Omega$ ]	22.4	11.2
Air core reactance [pu]	0.2	0.2
Magnetizing current [%]	1	1
Knee voltage [pu]	1.17	1.17

## A.4 Generators

### A.4.1 Synchronous Generator

Table A.4: Synchronous generator data

	Generator 1	Generator 2	Generator 3
Rating [MVA]	2800	2400	21000
Rated RMS Current [kA]	49	42	30.3
Rated RMS Voltage (l-n) [kV]	19.05	19.05	230.9
Base angular frequency [rad/sec]	314.16 ( $2\pi 50$ )	314.16 ( $2\pi 50$ )	314.16 ( $2\pi 50$ )
Inertia constant [s]	3.84	2.89	5
Mechanical Friction and Windage [pu]	0.04	0.04	0.04
Neutral Series Resistance [pu]	$10^5$	$10^5$	$10^5$
Neutral Series Reactance [pu]	0	0	0
Iron Loss Resistance [pu]	300	300	300
Armature Time Constant ( $T_a$ ) [s]	0.278	0.278	0.278
Potier Reactance ( $X_p$ ) [pu]	0.17	0.17	0.163
Unsaturated Reactance ( $X_d$ ) [pu]	2.13	2.13	2.0
Unsaturated Transient Reactance ( $X'_d$ ) [pu]	0.308	0.308	0.35
Unsaturated Sub-Transient Reactance ( $X''_d$ ) [pu]	6.0857	6.0857	5
Unsaturated Transient Time (Open) ( $T'_{do}$ ) [s]	0.234	0.234	0.28
Unsaturated Sub-Transient Time (Open) ( $T''_{do}$ ) [s]	0.0526	0.0526	0.039
Unsaturated Reactance ( $X_q$ ) [pu]	2.07	2.07	1.9
Unsaturated Sub-Transient Reactance ( $X'_q$ ) [pu]	0.234	0.234	0.375
Unsaturated Sub-Transient Time (Open) ( $T''_{qo}$ ) [s]	0.3538	0.3538	0.071
Ramp-up time when source [s]	0.1	0.1	0.1
Initial terminal voltage [pu]	1.1	1.1	0.9
Initial phase [rad]	0.0764	0	0

### A.4.2 Exciters

Table A.5: Excitor data

Exciters 1,2 & 3	
Regulator Gain (KA) [pu]	400
Regulator Time Constant (TA) [s]	0.02
Max Internal Regulator Voltage [pu]	14.5
Min Internal Regulator Voltage [pu]	-14.5
Max Regulator Output [pu]	6.03
Min Regulator Output [pu]	-5.43



# Appendix B

## Study case data

Table B.1: Study case data

Case	C [ $\mu F$ ]	TCSC [ $^{\circ}$ ]	Event
1	$\infty$ -133	-	-
2	$\infty$ , 150, 122, 120, 118	-	-
3a	122, 90	-,130	-
3b	117-51	125 - 133	-
4	80	100 - 130	-
5	2 x 400	100 - 114	-
6	2 x 50	100 - 130	2400 MVar out
7	2 x 55	100 - $\tilde{1}10$	1200 MW out



# **Appendix C**

## **Model in PSCAD**

Below a snip of one of the models made in the thesis is shown (Case 7).

