

Doctoral theses at NTNU, 2011:31

Bertha Maya Sopha
**Agent-Based Modeling and
Simulation of Clean Heating
System Adoption in Norway**

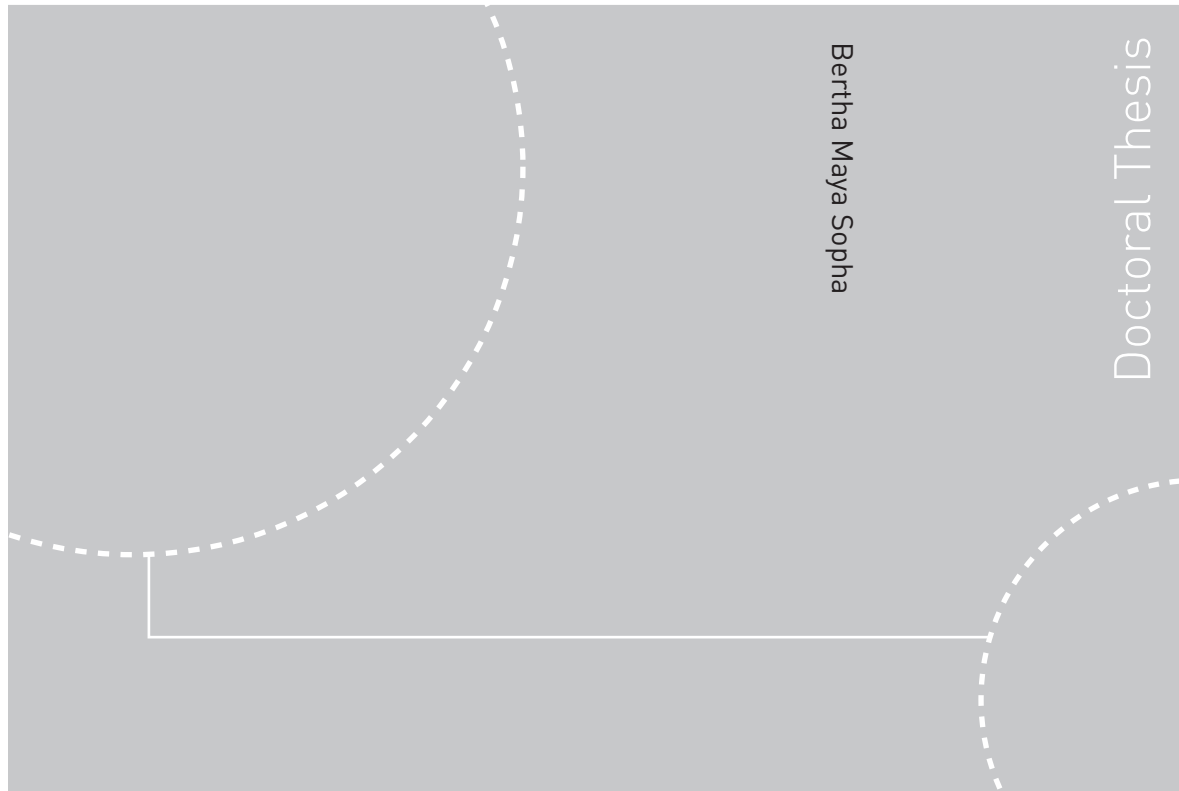

ISBN 978-82-471-2581-6 (printed ver.)
ISBN 978-82-471-2583-0 (electronic ver.)
ISSN 1503-8181

Doctoral theses at NTNU, 2011:31

NTNU
Norwegian University of
Science and Technology
Thesis for the degree of
philosophiae doctor
Faculty of Engineering Science and Technology
Department of Energy and Process Engineering
Industrial Ecology Programme

 **NTNU**
Norwegian University of
Science and Technology

 NTNU

 **NTNU**
Norwegian University of
Science and Technology

Bertha Maya Sopha

Agent-Based Modeling and Simulation of Clean Heating System Adoption in Norway

Thesis for the degree of philosophiae doctor

Trondheim, March 2011

Norwegian University of
Science and Technology
Faculty of Engineering Science and Technology
Department of Energy and Process Engineering
Industrial Ecology Programme



Norwegian University of
Science and Technology

NTNU

Norwegian University of Science and Technology

Thesis for the degree of philosophiae doctor

Faculty of Engineering Science and Technology
Department of Energy and Process Engineering
Industrial Ecology Programme

©Bertha Maya Sopha

ISBN 978-82-471-2581-6 (printed ver.)

ISBN 978-82-471-2583-0 (electronic ver.)

ISSN 1503-8181

Doctoral Theses at NTNU, 2011:31

Printed by Tapir Uttrykk

dedicated to

My husband, Sholeh Ma'mun

My daughter, Nada Salsabila

My son, Naufal Stjerne

My baby-to-be

Abstract

A sound climate policy encouraging clean energy investment is important to mitigate global warming. Previous research has demonstrated that consumer choice indeed plays an important role in adoption of sustainable technologies. This thesis strives to gain a better understanding of consumers' decision-making on heating systems and to explore the potential application of agent-based modeling (ABM) in exploring mechanism underlying adoption in which heating system adoption by Norwegian households is taken up as a case study.

An interdisciplinary approach, applying various established theories including those of psychology, is applied to create a model for consumer behavior and implement this behavior in an Agent-Based Model (ABM) to simulate heating technology diffusion. A mail-survey, carried out in autumn 2008, is a means to collect information for parameterizing the agent-based model, for gaining empirical facts, and for validating the developed model at micro-level. Survey sample consisted of 1500 Norwegian households drawn from population register and 1500 wood pellet users in Norway. The response rates were 10.3% and 34.6% for population sample and wood pellet sample respectively. This study is divided into two parts; empirical analysis and agent-based simulation.

The empirical analysis aims at fully understanding the important aspects of adoption-decision and their implications, in order to assist simulation. The analysis particularly contributes to the identification of differences/similarities between adopters and non-adopters of wood pellet heating with respects to some key points of adoption derived from different theories, psychological factors underlying the adoption-decision of wood pellet heating, and the rationales underlying Norwegian households' decisions regarding their future heating system.

The simulation study aims at exploring the mechanism of heterogeneous household decision-making giving rise to the diffusion of heating systems, and at revealing potential interventions toward wood pellet heating in Norway. A methodological approach of coupling ABM with empirical research is introduced to develop a conceptual model capturing households' adoption-decision processes which is parameterized with empirical data. Simulation results demonstrate that the generated data from simulation is reasonably able to generate independent historical data at both macro- and micro-levels. It indicates that the proposed methodology is promising.

As a whole, this thesis integrally addresses the study case using interdisciplinary perspective. The major contributions of the thesis lie in the inclusion of psychological factors, in addition to socio-demographic and technological factors, in adoption-decision, and the methodological proposal of coupling agent-based modeling (ABM) with empirical research and its application in the studied case.

Sammendrag

En virksom klimapolitikk for å stimulere til investeringer i fornybar energi er viktig for å redusere global oppvarming. Tidligere studier har vist at valg gjort av forbrukere spiller en viktig rolle for utbredelsen av bærekraftige teknologier. Denne studien søker å bedre forståelsen av hvordan forbrukere tar beslutninger angående oppvarmingssystemer og å identifisere potensielle anvendelse av agent-basert modellering (ABM) i anvendelse og diffusjon av oppvarmingssystemer. Anvendelse og diffusjon av oppvarmingssystemer blant norske husholdninger benyttes som en casestudie.

Studien har en tverrfaglig tilnærming, og anvender blant annet teori fra psykologi. Agent-basert modellering benyttes for å etablere konkrete problemstillinger som skal undersøkes. En spørreundersøkelse, gjennomført høsten 2008, brukes for å samle informasjon til parameterisering av en agent-basert modell, for å etablere empiriske fakta, og for å validere den utviklede modellen på mikronivå. Undersøkelsens utvalg besto av 1500 norske husholdninger trukket fra Folkeregisteret og 1500 brukere av trepellets i Norge. Svarprosentene var henholdsvis 10,3 % og 34,6 % for utvalgene av den generelle befolkningen og trepelletsbrukerne. Denne studien er delt i to deler, empirisk analyse og agent-basert simulering.

Hensikten med den empiriske analysen er å forstå viktige sider ved valg av oppvarmingssystem, og implikasjoner av disse sidene med hensyn til mulige tiltak. Den empiriske analysen understøtter slik simuleringen i andre del av studien. Et spesielt viktig bidrag fra den empiriske analysen er kunnskap om forskjeller mellom brukere og ikke-brukere av trepellets med hensyn til sentrale punkter i ulike teorier om anvendelse av teknologi, psykologiske faktorer som innvirker på utbredelsen av trepellets, og underliggende årsaker til norske husholdningenes valg av framtidig oppvarmingssystem.

Simuleringen tar sikte på å utforske hvordan heterogen beslutningstaking i husholdninger henger sammen med diffusjon av oppvarmingssystemer, og avdekker mulige tiltak rettet mot trepellets i Norge. En nyskapende kobling mellom ABM og empirisk forskning muliggjør utviklingen av en konseptuell modell for husholdningers anvendelsebeslutningsprosesser. Resultater gir en demonstrasjon på at simuleringen er rimelig i stand til å reprodusere uavhengige historiske data på både makro- og mikronivå. Dette indikerer at den foreslåtte metoden for å koble ABM med empirisk forskning er lovende.

Avhandlingen tar opp casestudien i et tverrfaglig perspektiv. De viktigste bidragene til avhandlingen er inkluderingen av psykologiske faktorer i anvendelsebeslutninger, i tillegg til sosio-demografiske og teknologiske faktorer, og den foreslåtte metoden for å koble agent-basert modellering (ABM) med empirisk forskning.

Acknowledgements

Alhamdulillah, a three-year (2007-2010) work of Agent-based modeling and simulation of clean heating system adoption in Norway carried out at the Industrial Ecology Programme, Department of Energy and Process Engineering, NTNU, Trondheim, Norway has been completed and reported in this Ph.D. thesis. I would like to express my deepest gratitude to Allah and all those people who have supported me along the way.

First of all, I would like to thank my supervisor, Professor Edgar Hertwich, for the chance given to me as his student. He has given me a liberty to follow my own interest while at the same time always supported me, for which I am grateful. This has made me such an independent researcher although it was a bit frustrating during the course of the work.

I would also like to thank my co-supervisor, Dr. Christian A. Klöckner, for introducing me to a rather soft-knowledge to my engineering-hard-knowledge and especially for his quick comprehensive feedbacks which really helped me to improve and broaden my point of view and skill.

My appreciations also go to Geir Skjevraak, who gave me an overview on the market of Norwegian heating system and helped me with technical issue during data collection, and Professor Annik Magerholm Fet, and Dr. Cecilia Haskins who introduced me Systems Engineering which I found very useful in managing multidisciplinary aspect of my study.

Further, I would also like to thank to all my colleagues at Industrial Ecology Programme for offering a good, friendly and lively environment at work; Hogne and Anders for their help translating questionnaires to Norwegian, Bhawna and Raquel for their humor, shared frustrations, advice, and chit-chat, Christian for their useful information and their assistances upon my arrival at IndEcol, Karin for sharing her useful academic experience, and last but not least, Linda Ariani Gunawan for reviewing my java codes.

Finally, I would like to thank my family for their unconditional love and understanding by which I was able to go through the hardest time of my study. Thank you for letting me to 'steal' your time and creating a healthy balance between work and free time.

I would also like to acknowledge Norwegian University of Science and Technology (NTNU), Trondheim, Norway, for the financial support.

Trondheim, November 2010
Bertha Maya Sopha

Table of Contents

Abstract	v
Sammendrag	vi
Acknowledgements	vii
Abbreviations	xi
List of Publications	xiii
CHAPTER 1 General Introduction	1
1.1 Background Case	1
1.2 Literature on Heating System Adoption	2
1.3 Research Questions and Objectives	4
1.3.1 Empirical Analysis	4
1.3.2 Agent-Based Simulation	4
1.4 Overview on the Contributions of the Thesis	5
CHAPTER 2 Literature Background	7
2.1 Modeling Approaches in Adoption and Diffusion Studies	7
2.2 Agent-Based Modeling	8
CHAPTER 3 Data Collection	11
3.1 Survey	11
3.2 Sample	11
3.2.1 Bias	13
3.3 Questionnaire Design	14
CHAPTER 4 Empirical Analysis	17
4.1 Adopter and Non-adopters of Wood Pellet Heating	17
4.2 Decision Process of Wood Pellet Heating	19
4.3 Anticipated Future Heating System Choice	21
4.3.1 Determinants of anticipated future heating system choice for population sample	22
4.3.2 Determinants of anticipated future heating system choice for wood- pellet sample	24

CHAPTER 5 Agent-Based Modeling and Simulation	29
5.1 Methodological Proposal: Coupling ABM with Empirical Research	29
5.2 Agent-Based Model	30
5.2.1 Agents	30
5.2.2 Heating Systems	32
5.2.3 Decision-Making Process	33
5.3 Implementation	36
5.4 Verification, Calibration, and Validation	37
5.5 Structure of Social Network	40
5.6 Scenario Analysis	41
5.6.1 Same Perceived Attributes as the Best Available Technology	42
5.6.2 Individual vs. Simultaneous Development for Wood Pellet Heating	43
5.6.3 Intervention Focusing on Norms/Values	44
5.7 Limitations	46
CHAPTER 6 Summary and Suggestions for Future Work	49
6.1 Summary	49
6.2 Suggestions for Future Work	51
6.2.1 Empirical Analysis	51
6.2.2 Simulation Study	51
References	53
APPENDIX A - Questionnaires	
APPENDIX B - Papers	

Abbreviations

ABM	Agent-Based Modeling
ANOVA	Analysis of Variance
CDAM	Comprehensive Determination Action Model
COSTS	Total Cost
DoI	Diffusion of Innovation
FR	Functional Reliability
GIS	Geographical Information System
IAQ	Indoor Air Quality
IEA	International Energy Agency
NEP	New Environmental Paradigm
NOVAP	Norsk Varmepumpeforening
OED	Olje- og Energidepartementet (Ministry of Petroleum and Energy)
SI	Systems of Innovation
SSEC	Fuel Supply Security
TPB	Theory of Planned Behavior
WORK	Required Work

List of Publications

1. Sopha, B. M., Klöckner, C. A. and Hertwich, E.G. Adopter and non-adopters of wood pellet heating in Norway, *Biomass and Bioenergy* 2011: 35(1), 652-662
2. Sopha, B. M. and Klöckner, C. A. Psychological factors in the diffusion of sustainable technology: A study of Norwegian households' adoption of wood pellet heating, submitted to *Renewable & Sustainable Energy Reviews* (under review)
3. Sopha, B. M., Klöckner, C. A., Skjevraak, G. and Hertwich, E.G., Norwegian households' perception of wood pellet stove compared to air-to-air heat pump and electric heating, *Energy Policy* 2010: 38(7), 3744-3754
4. Sopha, B. M., Klöckner, C. A. and Hertwich, E.G. Modeling adoption and diffusion of heating system in Norway: Coupling agent-based modeling with empirical research, submitted to *Environmental Modelling and Software* (under review)
5. Sopha, B. M., Klöckner, C. A. and Hertwich, E.G. The influence of the social network structure on the diffusion of heating system in Norway. In Ernst, A. and Kuhn, S. (Eds) 2010. *Proceeding of 3th World Congress on Social Simulation WCSS 2010*, Kassel, Germany: Center for Environmental Systems Research, University of Kassel.
6. Sopha, B. M., Klöckner, C. A. and Hertwich, E.G., 2011. Exploring policy options for a transition to sustainable heating system diffusion using an Agent-Based Simulation, accepted in *Energy Policy* 2011
7. Sopha, B. M., Fet, A. M., Keitsch, M. M., and Haskins, C., Using systems engineering to create a framework for evaluating industrial symbiosis options, *Systems Engineering* 2010: 13(2), 149-160¹

¹ A part from this current research, this article is based on the previous work on the modeling industrial symbiosis during the period of 2006-2007 under the same PhD-grant.

General Introduction

1.1 Background Case

Environmental problems, such as climate change, have been important issues in today's generations. The question of how to meet present needs without sacrificing the ability future generations to satisfy their needs is thus a central policy topic in the debate over sustainable development. The convergence toward a sustainability path depends to a great extent on the diffusion of environmentally friendly technologies. In fact, the diffusion of these technologies is often slow and tedious (Painuly, 2001; Negro et al., 2010). The diffusion of wood pellet heating in Norway is one of the example cases.

The market diffusion of wood pellet heating in Norway is very modest. The objective of increasing the use of renewable energy sources was initially based on the Norway's commitment to Kyoto Protocol which was ratified in 1997. Norway committed to restrict the increase of greenhouse gases emissions to not more than 1% in the period 2008-2012 compared to 1990 level (IEA, 2005). The Norwegian Commission on Low Emissions has thus proposed transition to CO₂-neutral heating through increased use of heat pump, wood pellets, thermal solar energy, and others, in order to reduce Norway's emissions of greenhouse gases by 50-80 percent by 2050 (Randers et al., 2006). As a result, several policy measures to promote environmentally friendly heating systems have been undertaken. One such action was the creation of Enova, which was established in 2001 as a public enterprise owned by the OED (Ministry of Petroleum and Energy), aiming at restructuring environmentally friendly energy consumption and energy generation in Norway (Bjørnstad, 2005). At the moment, Norway is in negotiations with the EU regarding the renewable energy directive wherein EU wants Norway to produce even more renewable energy. The negotiations will subsequently be the next driver to keep pace with the diffusion of sustainable technologies in Norway.

According to Enova (2003), energy consumption for room heating accounts for about 41% of total energy use in Norwegian households, making it the greatest potential area to reduce environmental impacts in residential area. Adoption of more efficient and renewable systems heating system in Norway thus plays an important role. Enova has offered a subsidy scheme of up to 20% of total installation costs for air-to-air heat pump and wood pellet heating in order to reduce the use of oil-based heating systems together with reducing residential electricity consumption and dependency (Innstilling til Stortinget

fra energi- og miljøkomiteen nr. 133, 2002-2003). Although Norwegian electricity is based on hydropower which is 100% renewable, steady demand growth has now caught up with electricity supply. Periods of low precipitation and/or high demand of energy due to long and cold winters, such as 2002-2003 and 2010, lead to high energy prices, and to capacity problems of meeting the demand. Norway has thus to import electricity which is often generated from coal. Consequently, reducing electricity consumption and dependency of households is particularly important for Norway, because reduced electricity use will reduce the need for electricity import during low precipitation/high demand periods, and furthermore, make electricity available for industry, electric cars, and export in which the electricity imported from Norway replaces electricity produced abroad based on fossil energy sources (REMODECE Project, 2006). A life-cycle assessment shows that clean-burning wood stoves can result in overall environmental and climate benefits in Norway if the saved electricity is exported (Solli et al., 2009). While the subsidy for heat pumps has been successful, the subsidy for wood pellet heating did not lead to a substantial diffusion of wood pellet heating. The market share of wood pellet heating has been continuously low and stagnating (Statistics Norway, 2006).

1.2. Literature on Heating System Adoption

Low diffusion of new technology is actually not new phenomenon in adoption and diffusion studies. To address the phenomenon, adoption and diffusion of a technology have basically been studied at either macro level (e.g., Systems of Innovation (SI) approach) or micro level (e.g., adopter-centric approach), qualitatively and/or quantitatively. Some studies focus on the supply side of the process (e.g., Grübler, 1998) and some studies focus on demand side of the process (e.g., Rogers, 2003).

There are, however, only few adoption and diffusion studies of energy-related choice, particularly in heating system application. Most of the existing studies implemented socio-economic factors as predictors of heating system choice, and applied discrete choice modeling wherein a statistical technique, such as logit or probit regression which is used to predict the probability of a choice from several predictor variables, is utilized. An example is the work by Kasanen and Lakshmanan (1989) who identified circumstances that constrain the choice of a heating system in Finland. A logit model was used to identify variables that explain homeowner's choice behavior on heating systems. Age and income were found to be significant. The important contribution was the facts that households were influenced by the decisions made by others, and their location, e.g. city, rural area, etc. Scodari and Hardie (2007) presented an analysis of the household wood stove acquisition decision in the US. This study confirmed that those who installed wood stoves expected to decrease home-heating cost. The model predicts that the probability of a household acquiring a wood stove varies inversely with age and education of the household's head and directly with family size.

With respect to Norwegian case studies, Brottemsmo (1994) did a comparative study on the choice of heating technology, e.g. solid fuel, liquid fuel, electricity, etc., in Norway

for the years 1980 and 1990 using a discrete choice model. The variables of average outdoor temperature, floor space, types of dwelling, number of adults and number of children, were included. High oil prices in 1986 reduced heating with liquid fuel. Nesbakken (1998) identified factors that influenced the choice of heating systems in Norway by employing statistical data from 1971-1990 using a discrete choice model. Factors like income, size of household, type of house, dwelling ownership, and capital cost of the necessary equipment, influenced the heating system choice in Norway significantly. During that period of time, electric heating systems were the most common choice, followed by a combination of electric and oil heating systems, a combination of electric and wood heating systems, and a combination of electricity, oil, and wood heating systems. Electricity was preferred over other heating systems when income was high and in housing cooperatives. Meanwhile, wood was preferred in detached houses and for larger household size. The higher the annualized capital cost and the operating costs, the lower the probability of choosing wood compared to electricity alone.

Mahapatra and Gustavsson (2008) investigated the heating system choice of Swedish households on both the macro- and the micro-levels. Both System of Innovation and adopter-centric approaches were applied. The main contribution was the inclusion of heating system performance, interpersonal communication, and role of mass media, factors in which have been neglected in previous studies.

The literature review on heating system choice indicated that there are indeed potential areas not yet sufficiently researched. For example, psychological factors underlying adoption decisions have not yet been touched in heating system studies, whereas these factors have been extensively used in exploring behavioral choice in various applications. Such applications can be found in recycling (Tonglet et al., 2004) and transport choice (Bamberg et al., 2003). Another potential area is the representation of social interaction in decision-making. While social interaction has been demonstrated as an influential factor in diffusion (Midgley et al., 1992; Valente, 1996), it has not yet been appropriately addressed in the previous studies of heating systems.

In addition, current Norwegian studies in relation to heating system have so far contributed to investigate the potential for bio-energy use in Norway (Trømborg et al., 2008), the effect of subsidy scheme to the adoption of air-to-air heat pump and wood pellet stoves (Bjørnstad, 2005), and opportunities and barriers for wood pellet heating in Norway from the supply side (e.g., Nashoug and Pedersen, 2004). Nashoug and Pedersen (2004) pointed out that the biggest barrier of wood pellet use lies at the demand side. This thesis consequently attempts to complement the existing studies by addressing adoption choices made by decentralized heterogeneous households by embracing two novel factors, i.e., psychological factors and social interaction.

1.3 Research Questions and Objectives

Given the fact that wood pellet heating has not been further adopted despite the subsidy leaves a question associated with the potential interventions necessary to introduce wood pellet heating. While existing studies so far have discussed wood pellet potentiality mostly at the macro-level, this study aims particularly to reveal decision-making of heating systems by households. A thorough analysis in this field will help to understand which factors; technical, economic-demographical, social, and psychological, are crucial in heating system decision-making, so that potential intervention can thus be identified.

Moreover, this present study aims to gain a better understanding of how individual household decision-making affects the diffusion of heating systems. Therefore, this study employs Agent-Based Modeling (ABM) as a methodological approach for modeling heterogeneous households' decision-making which produces the diffusion of heating systems. This methodology is intuitively appealing because it enables the emergence of phenomena resulting from decentralized heterogeneous households' decision-making, and the modeling of social interaction in decision-making. To sum up, this study is to inquiry into the following research questions:

1. *What are the influential factors in decision-making of heating systems by households, and what are the potential interventions favoring clean heating system?*
2. *Is the application of Agent-Based Modeling (ABM) capable of generating patterns of heating system adoption and diffusion in Norway?*

In the pursuit of research questions, the thesis is thus divided into two parts of study which consists of empirical analysis and agent-based simulation, according to the chronological development, which are described below.

1.3.1 Empirical Analysis

The goal of this part of the work was to gain empirical evidences of household decision-making and to fully understand their implications. This work relates to identify the differences/similarities between adopters and non-adopters of wood pellet heating with respect to some key points of adoption derived from different theories, to determine psychological factors underlying the adoption-decision of wood pellet heating, and to understand the rationale underlying Norwegian household decisions on selecting anticipated future heating system. The results of this work are presented in detail in Paper 1, 2, and 3, listed in List of Publications.

1.3.2 Agent-Based Simulation

The simulation study is to experiment whether agent-based modeling could be a feasible technique to evaluate the adoption of heating systems by Norwegian households. The design of simulation is specifically to identify the potential interventions enabling the

diffusion of clean heating system. The main features of the design are the distinction of households according to their specific attributes and the incorporation of social interaction in decision-making. This work comprises a methodological proposal combining agent-based model and empirical research, construction of a conceptual model which captures households' adoption-decision process, model calibration and validation, as well as, scenario analysis of potential intervention toward wood pellet heating. The effect of various structures of the social network on diffusion is also investigated. The results of this work are presented in detail in Paper 4, 5 and 6 listed in the List of Publications.

1.4 Overview on the Contribution of the Thesis

This section provides an overview of the papers' contributions and how they relate to each other. Households indeed differ when it comes to several aspects of decision-making in which these differences lead to a different choice. Thus one policy might be effective reaching some but not others. Policies should hence be designed for different target groups.

Paper 1 provides empirical facts concerning the similarities and differences between adopters and non-adopters of wood pellet heating. The results indicate that there are significant differences between adopters and non-adopters with respects to attributes (i.e., age, income, education, location, decision-making-related factors) and perceptions. Differences in values and information-related factors are non-significant between the two groups. One novel interesting finding from this study is that although both adopter and non-adopter groups share the same level of environmental values, the perception of which heating system is the most environmentally friendly differs significantly. Providing information on how environmentally friendly a heating system is, is of importance considering that a desire for an environmentally friendly heating system is identified as the top motivation by adopters for installing wood pellet heating, followed by low operation costs and an increase in electricity prices. Meanwhile, the economic barrier, followed by difficulties to refit the house, is the most important barrier for non-adopters so that the average subsidy required by this group is about 64% of the total installation cost.

Paper 2, which applied an integrated model combining a psychological model, values, and perceived heating system attributes, supports finding from Paper 1 indicating that deliberation is the most applied strategy by wood pellet adopters. Two important findings relevant for designing policy/interventions are that the influence of values/norms is inferior in comparison to the technology-related factors, i.e. functional reliability and costs, and that habitual decision-making could hinder the adoption of wood pellet heating. The results then suggest that the improvement of the subjective evaluation of the functional reliability of wood pellet heating should have first priority whereas focusing on norms/values should not be prioritized for

now. Presenting alternatives and increasing decisional involvement could then be other promising strategies to reduce cognitive lock-in in decision-making.

Paper 3 presents motivations/rationales behind the future anticipated choice of heating system. Results indicate that age, income, location, communication, heating system attributes, and decision strategies, are the influential factors. Paper 3 supports finding of Paper 2 in a way that technology-related factors of wood pellet heating should be perceived advantageous. This paper also points out the necessity of supporting the existing network of adopters to increase the adoption of wood pellet heating.

While Papers 1-3 provide insights on the aggregated level, the simulation research reflects heterogeneity of households better and explicitly models social interaction among households in decision-making. The simulation thus facilitates the understanding of mechanism of heterogeneous household decision-making resulting in the cumulative adoption of various heating systems (diffusion).

Paper 4 proposes a methodological approach of coupling an agent-based model (ABM) with empirical research. The paper describes chronological steps of the proposed methodology, i.e. theory building, empirical data acquisition, model construction, and simulation. Validation of the model confirms that the model in general is able to reproduce the pattern of independent historical data.

Paper 5 describes the examination of the effect of various structures of social networks on heating system diffusion. This paper indicates that structure of social network indeed influences the diffusion, in line with literatures of adoption and diffusion.

Paper 6 presents scenario analysis exploring potential interventions favoring increased use of wood pellet heating in Norway. The paper examines the general reaction of the macro-level diffusion caused by changes/interventions occurring on the household-level. Three suggested interventions derived from simulation are that heating attributes of wood pellet heating should be improved so that they are superior than its competitors (providing proof of Diffusion of Innovation theory), that simultaneous development of wood pellet heating (e.g., functional reliability and stable fuel price) should be undertaken (providing proof of existing hypothesis concerning wood pellet heating development by Egger and Öhlinger (2002), and that intervention related to norms/values should not be prioritized (providing proof of previous finding from Paper 2).

Literature Background

Diffusion is defined as the process of spreading a new idea or new product through a population, while adoption deals with the psychological process through which an individual accepts or rejects a new idea or a new product. Diffusion therefore emerges from aggregated adoption-decisions by individuals. The process of technology adoption and diffusion is complex. The availability of technologies which are efficient from an economic point of view does not guarantee that the technologies will diffuse. Accordingly, a number of models exist in the literature attempting to explain adoption and diffusion phenomena. This chapter provides a brief overview of modeling approaches which are often utilized in adoption and diffusion studies (section 2.1) and a short description of agent-based modeling (ABM) as the selected modeling technique and rationale of it being used in this research (section 2.2).

2.1 Modeling Approaches in Adoption and Diffusion Studies

The development of science has generally been dominated by the use of modeling to a large extent. A model is considered as a metaphor of a real-world system. According to Gilbert and Troitzsch (1999, pg. 2), *a model is simplification – smaller, less detail, less complex, or all of these together – of some other structure or system*. The general purpose of modeling is therefore to understand some aspects of the real-world system of interest. A large number of different approaches to modeling adoption and diffusion, either involved mathematical formulation or the use of computer simulation, have been utilized, although the latter is still young but rapidly growing.

Within the context of technology adoption and diffusion, a number of models have been developed in literatures (Geroski, 2000). The **epidemic model** or also known as contagion model, which builds on the premise that the lack of information about new technology limits the speed of usage, shows that the process of technology diffusion could be modeled with a differential equation that has the logistics function as the solution. This function corresponds to the well-known S-shaped curve that relates number of adopters of a technology or its market share to time. This model assumes that diffusion results mainly from changes in expected profitability of the adoption and the dissemination of information. A **discrete choice model** analyzes individual adoption decisions. Statistical techniques such as logit regression, probit regression, or multinomial regression

are normally used. Differing from epidemic model, a discrete choice model addresses how different characteristics of individuals affect the probability of adopting a technology. This model has been a dominating model in the studies of heating system adoption (see section 1.2). Another more recent model is **evolutionary model** which is based on the idea of agents' heterogeneity and imperfect information. Agent-based modeling is a modeling technique generally used in the evolutionary model, and will be discussed further in the following section.

2.2 Agent-Based Modeling

Agent-based modeling (ABM) involves the use of computer simulation. Computer simulation is better than mathematical modeling in cases which need to model heterogeneity of social actors and processes, interactions amongst social actors, particularly dynamic one, and emergent properties. Agent-based modeling is a new technique but has been gained more attention due partly to its interdisciplinary appeal and to the growth in computer processing power.

This technique is clearly distinguished from other kinds of modeling research by focusing on the concept of agents. The agents can represent people, companies, vehicles, etc., which have different rules governing their behavior and interact with other agents and/or the environment. The system, (macro) level behavior, emerges as a result of interactions of many individual-agent behaviors.

Agent-based modeling can be found in diverse disciplines, such as cybernetics, biology, physics, etc., but it is relatively new in social sciences (Janssen, 2007). The first application of agent-based modeling in the social science research can be traced back to the work by Schelling (1969 and 1978) in which he demonstrated that a small preference for one's neighbors to be of the same race could lead to total segregation, analogies to real-world phenomena. Epstein and Axtell (1996) built a computer simulation called 'Sugarscape' in which heterogeneous and autonomous agents competed for resources that were unequally distributed over a 2-dimensional environment. This model provided the basis for more developed models, e.g., norm formation through cultural diffusion (Flentge et al., 2001) and the emergence of communication and cooperation in artificial societies (Buzing et al., 2005). Another interesting application was to model the mysterious disappearance of the nation of Anasazi in the south-west of the USA at about 1300 A.D (Gumerman et al., 2002). Agent-based modeling has nowadays been applied broadly including in the adoption and diffusion studies (see Table 2-1).

Table 2-1 Application of ABM in a business context (Source: Bonabeau, 2002)

Area	Application
Flows	Evacuation, traffic, customer flow management
Markets	Stock market, shopbots and software agents, strategic simulation
Organizations	Operational risk, organizational design
Diffusion	Diffusion of innovation, adoption dynamics

Due to the bottom-up approach, ABM provides benefits in comparison to other modeling techniques (Bonabeau, 2002). First, ABM captures emergent phenomena which result from the interactions of heterogeneous agents of the system. Emergence is defined as the coming up of characteristics that has not existed before agents have interacted/merged. Emergence is more than the sum of its part due to interactions between parts. One example is the brain consisting of millions of neurons in which each neuron has no thought but the interactions among neurons allows brain to think. Second, ABM is capable of tackling problems with systems involving high levels of heterogeneity and interactions of components. Third, ABM is flexible in how it can be designed and programmed reflecting different degrees of model complexity as it allows changing levels of abstraction and aggregation. In general, ABM is best suited to handle cases in which the population is heterogeneous, agents exhibit complex behavior, interaction between the agents is evolving, topology of the interactions is heterogeneous and complex, and special relationships are important. It can also be linked to Geographical Information System (GIS). ABM is hence relatively well-suited to sustainable development studies because of its potential for cognitive integration; integration of various kind of knowledge, scientific disciplines, different time spans and different institutional and ontological levels (Boulanger and Brechet, 2005).

Within this research context, ABM is thus proposed as a methodological approach to investigate the effect of underlying adoption-decisions on the diffusion of heating systems, and to explore potential interventions towards renewable heating systems in Norway (see Chapter 5 on Simulation Study), due to some specific reasons as follows,

1. The adoption and diffusion process involves heterogeneity of consumers and consumer interactions.
2. ABM is particularly useful for exploring adoption and diffusion processes by providing micro-founded explanation (technology adoption by households) to understand macro level phenomena (technology diffusion).
3. The study is based on real consumers which reside in specific locations in Norway.
4. It allows incorporating theoretical and empirical findings in the process of model development and evaluation.

Despite the benefits offered by ABM, there are some challenges related to the application of agent-based modeling in social sciences. Social sciences deal with human beings while other sciences, i.e., natural sciences, deal with natural phenomena which typically are related to objects. This imposes different issues that are important to social application. Modeling human agents and their relationships is challenging due to the fact that human behavior does not confirm to rules in the same and fixed relationship as the behavior of atoms or ants. Moreover, humans are heterogeneous, not always rational, and influenced by others, which make the modeling effort even more problematic. Modeling always requires one to simplify, but as a consequence one must

be careful to draw inferences to the real world from a model. Another issue relates to the difficulty to quantify factors such as irrational behavior, subjective choices, etc. This may then constitute a problem in interpreting the simulation outcomes. In general, quantitative outcomes of social simulation must be interpreted on a qualitative level. The accuracy and completeness of the model input determine whether the output should be used for either qualitative insights or quantitative forecasting. Sensitivity to initial conditions and small variations in interaction rules is another limitations of ABM. Requirement of high computational speed has also been problematic particularly when it comes to large modeling systems.

The largest problem for ABM is actually the emergence. It is easy to show that new, complex behavior emerges – that is just a result of the model setup. It is however very difficult to test whether the emerging complexity has any relationship to our real world, and hence to make claims that the underlying mechanisms on the micro-level or the precise interactions among the agents are confirmed/validated by the model. Developing cases in which ABMs are evaluated and/or validated is challenging and hence calls for fairly simple applications to test and develop the modeling technique and develop an intuition for its behavior and an understanding of the model's capabilities and limitations.

Furthermore, as ABM is relatively new and immature, there is still a lack of standards for programming platforms as well as a lack of techniques for model comparison and model generality.

Data Collection

This chapter is concerned with data collection for both empirical analysis and ABM simulation. Section 3.1 describes data collection method and rationale behind the selected method, followed by sampling method and basic statistical tests of the samples in section 3.2, and design of questionnaires in section 3.3.

3.1 Survey

Data was collected mainly to parameterize model simulation. However, other data is also being collected to acquire empirical facts of Norwegian households and to validate simulation model at micro-level. A survey was chosen as a method for collecting data for several reasons. First, ABM simulation requires information representing general population's decision-making on heating systems. Thus, the collected data is meant to provide required information describing the characteristics of a large population. Second, empirical analysis of the survey also aims to test the influence of a combination of already established predictors from existing studies (Brottemsmo, 1994; Nesbakken and Strøm, 1994; Nesbakken, 1998).

There are two main methods of collecting survey information, i.e., a mail-out or web-based questionnaire survey, and telephone or in-person interviews. According to Donnelly (2007), the advantages and disadvantages of each method are presented in Table 3-1 and Table 3-2.

After careful evaluation on the advantages and disadvantages of various methods, a mail-survey is then selected. The specific reasons are that the survey consists of long and complex questions which make telephone interview seem not an option, while on the other hand, cost- and time-constraints prevent us to conduct in-person interviews. Web-survey does not seem to be a better alternative than mail-survey because the desired target population does not mainly consist of internet users.

3.2 Sample

Sample selection is critical to the acceptance of whether the results of the study could be generalized to represent the population under study. There are two different approaches for sampling; non-probability and probability sampling approaches. While non-probability sampling method does not involve random selection, the latter does.

Table 3-1 Advantages and disadvantages of Web-or Mail-survey vs. Telephone/In-person interview survey (Source: Donnelly, 2007)

Survey Type	Advantages	Disadvantages
Web-or Mail-survey	<ul style="list-style-type: none"> Less expensive May contain longer and complicated questions Respondents can answer at their own convenience Suitable to administer long and complex questions No interviewer induced bias Standardized questions make measurement more precise by enforcing uniform definitions upon the participants and thus high reliability can be obtained 	<ul style="list-style-type: none"> Longer response time Lower response rate Depends on subjects' motivation, honesty, memory, and ability to respond It may be hard for participants to recall information or to tell the truth about a controversial question Unclear question may not be answered by the respondents May have low validity when researching affective variables Not suitable for issues requiring clarification
Telephone/In-person interview survey	<ul style="list-style-type: none"> Can ask for clarification on response and additional detail Very good response rate 	<ul style="list-style-type: none"> High cost

Table 3-2 Advantages and disadvantages of Web- vs. Mail-survey (Source: Donnelly 2007)

Survey Type	Advantages	Disadvantages
Web-survey	<ul style="list-style-type: none"> Very low cost Shorter response time (fast) 	<ul style="list-style-type: none"> Random respondents if the survey appears on Webpage
Mail-survey	<ul style="list-style-type: none"> Low cost Give access to dispersed samples, often used to measure widespread opinions of the general population 	<ul style="list-style-type: none"> Longer response time May result in biased sample

Sample of this study consists of two groups, i.e., non-wood pellet adopters (also referred to as population sample) and wood pellet adopters (adopter sample). For the first group, 1500 questionnaires were sent to Norwegian households drawn as a random sample from the population register. A random sample rather than a stratified random sample was chosen due to the lack of access to stratification variables for Norwegian households during the sampling procedure. However, the sample size was increased to compensate for the negative effect of sampling bias in a simple random sample (Lohr, 2009). This sample represents households who do not use wood pellet heating. The second group represents adopters of wood pellet heating in Norway. 1500 additional

questionnaires were sent to wood pellet users in Norway. The second sample represented almost the complete population of wood pellet users in Norway. The list was acquired from wood pellet companies in Norway.

A household is the unit of analysis. Hence, one member of the household was asked to answer the paper-pencil questionnaire, and the household members were left to decide who was the most qualified. Only homeowners are chosen as respondents because they have the authority to make decisions about heating systems independently.

The questionnaires were sent by mail in autumn 2008. After three weeks, the response rates in the population sample and wood pellet sample were 10.3% and 34.6 % respectively. 137 additional responses from the population sample and 150 from the wood pellet sample were received after a reminder containing another copy of the questionnaires was sent out after three weeks. This resulted in a response rate of 19.4% (291 responses) for the population sample and 44.6% (669 responses) for the wood pellet sample. Several respondents did not answer the entire questionnaire, and therefore the response rate varies for each question.

All the empirical analysis (Chapter 4) is based on both groups/samples; population sample and adopter sample. The simulation study (Chapter 5) however only utilizes the population sample.

3.2.1 Bias

Bias examines whether the sample accurately represent the population under study or not. This sub-section aims to test sampling bias and non-response bias.

To test if the random population sample of 1500 varied significantly with respect to age, a Chi^2 test comparing age distributions of population sample to that of population registry is conducted without a significant result ($Chi^2 = 65.799$; $df = 73$; $p = 0.713$). With respect to the regional distribution, a Chi^2 test comparing the distribution of households over Norway's nineteen provinces in the sample (see Figure 3.1) to the expected distribution based on data from population registry is also conducted without a significant result ($Chi^2 = 17.633$; $df = 18$; $p = 0.480$). In other words, the composition of the original population sample is representative with respects to age and regional distribution of Norwegian households.

Wood pellet sample also shows insignificant difference with respect to age when comparing to age distribution of population registry ($Chi^2 = 45.423$; $df = 73$; $p = 0.995$). Even though the regional distribution of wood pellet sample is significantly different from that of population registry ($Chi^2 = 488.028$; $df = 18$; $p < 0.000$), this sample is representative of all Norwegian wood pellet users, as it accounts for roughly 80% of all wood pellet users in Norway.

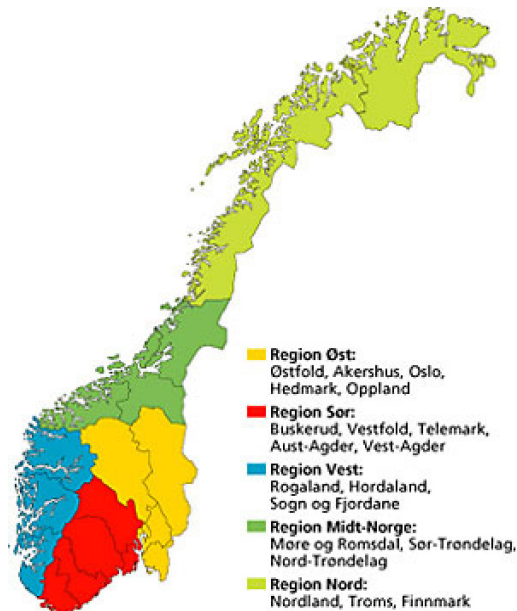

Figure 3-1 Norwegian regional division (Adapted from Statistics Norway, 2010)

To test non-response bias, a Chi^2 test is performed for both groups to compare the original and the response sample by provinces/districts. The tests revealed that there is no statistical difference between the original samples and response samples for wood pellet sample ($Chi^2=2.031$; $df=13$; $p=1.000$) and non-wood pellet (population) sample ($Chi^2=8.689$; $df=18$; $p=0.967$). Thus, a self-selection bias could not be found with respect to regional distributions. Other data on the original population to test self-selection bias in the response samples are not available. It might, therefore, be possible that self-selection processes result in an undetected bias, especially as the response rate in the two groups is different.

3.3 Questionnaire Design

There are two types of questionnaires, one for each sample group (see Appendix A). The questionnaire for the first group, a population sample, is organized into five parts, while the questionnaire for the second group, adopters of wood pellet heating, is organized into six parts.

Part A encompasses general questions on socio-demographic factors. Examples of such information include gender, age, income, education, location, ownership of the house, and heated area.

Part B concerns with respondents' communication habit when making decision on heating systems. Questions, concerning number of recommenders, the importance of

recommendation, number of peers to whom a household recommend its heating system, and types of recommended heating system, are included.

Part C, consisting of 16 questions for a population sample and 20 questions for a wood pellet adopter sample, is related to decision-making about the heating system. Specific questions for the adopter group addresses the motivation for installing wood pellet heating, benefits of using wood pellet heating, willingness to continue using wood pellet heating in the future, and the most important factors during decision-making of wood pellet heating. Conversely, specific questions for the non-adopter group are dealing with perceived barriers and subsidy required for installing wood pellet heating.

Part D comprises questions to analyze psychological factors affecting the decision-making process for three types of heating system, i.e., electric heating, heat pump, and wood pellet heating. Personal norm (PN), attitudes (ATT), perceived behavioral control (PBC), and intention (INT), are measured with two items each. The measures are adopted from the work of Klöckner and Blöbaum (2010) which are modified with respect to heating system choice, and then, translated to Norwegian. Indicators of perceived functional reliability (FR), required work (WORK), indoor air quality (IAQ), total cost (COSTS), and fuel supply security (SSEC), are adapted from Moore and Benbasat (1991) which are modified according to the needs of this study, and then translated to Norwegian. The answering scales in this study are used in accordance with the original studies in which the items are derived from: a 7-point Likert scale from “totally disagree” coded as 1 to “totally agree” coded as 7. In addition, this part also inquiries respondents to rate their perception on how environmentally friendly of various heating systems are, and number of installation decisions of heating system in total and for various individual heating systems.

Part E involves questions assessing household’s basic value and environmental value. The extent of materialistic or post-materialistic value orientation is measured using 6 indicators on a 5-point Likert scale (Vogel, 1994). The higher the score is the higher is the degree of post-materialism. The lower the score is the higher is the degree of materialism. To measure environmental value, the New Environmental Paradigm (NEP) scales are adopted from Lalonde and Jackson (2002) who based their scale on the original work by Dunlap and van Liere (1978). Each NEP subscale (balance of nature: NEP_{BON} ; limits to growth: NEP_{LTG} ; and human domination: NEP_{HD}) is measured by two items of 5-point Likert scale. All the measurements are translated to Norwegian.

An additional part for wood pellet heating adopter group (Part F) addresses the technical issues based on the experience of using wood pellet heating, such as time required for operation and maintenance, satisfaction level, and open questions about experienced problems related to wood pellet stoves, suppliers of wood pellet stoves, and quality of wood pellets.

A pilot study for testing and refining the written questionnaires had been conducted first with 35 homeowners before the questionnaires were sent to the selected samples.

Empirical Analysis

Empirical analysis of the survey results aims to explore empirical facts regarding important factors influencing adoption of heating systems by Norwegian households and their implications, in order to assist simulation design. The study involves the analysis of the similarities and differences between adopters and non-adopters of wood pellet heating with respect to some key points of adoption derived from different theories (section 4.1), psychological factors underlying the adoption-decision of wood pellet heating (section 4.2), and the rationale motivating a Norwegian household to choose one type of anticipated future heating system over another (section 4.3). Statistical analysis is the main technique for empirical analysis; however, specific methods are adopted according to the purpose of the analyses, and briefly described in each section. Major findings from the empirical study are recapped in this chapter while details of approaches and discussion can be found in the attached articles in Appendix B (Paper 1, 2, and 3).

4.1 Adopter and Non-Adopters of Wood Pellet Heating²

Existing theories and empirical researches have indicated that consumer characteristics influence choice of a technology. For example, the diffusion of innovation theory (Rogers 2003) recognizes that different characteristics of potential adopters, such as socio-demographic characteristics and personality, may ease or hinder adoption of an innovation. It is also echoed by economic studies which differentiate consumers based on lifestyle as an important driver of consumption (Reusswig et al., 2008). Within social-psychology, Janssen and Jager (2002) further argued that the characteristics of a consumer may also influence the decision strategy she/he employs, thereby affecting the adoption and diffusion rate. Furthermore, Kasanen and Laksmanan (1985), and Mahapatra and Gustavsson (2008), demonstrated that culture, socio-economic characteristics, and interpersonal communication, are factors influencing heating system choice. The understanding of consumer characteristics consequently becomes more important particularly when it comes to policy design because effective policy should consider target group.

² Summarized from Paper 1, *Biomass and Bioenergy* 2011: 35(1), 652-662

Paper 1 hence aims to explore the similarities/differences between adopters and non-adopters of wood pellet heating in Norwegian households by comparing the two groups with regard to several points which are commonly recognized as important in adoption studies.

Analyses of Variance (ANOVA) and Pearson's chi-square tests are used to determine the differences between the groups for interval and nominal data respectively. A non-parametric test, i.e., a Mann Whitney U test, is used for ordinal data. Major important findings are described in the following.

1. With respect to some attributes, the adopter group demonstrates characteristics of early adopters; on the other hand, the non-adopter group displays characteristics of late adopters, according to diffusion and innovation theory (Rogers, 2003). However, the adopter group has lower income and education levels as compared to the non-adopter group, which contradicts the theory.
2. There are no significant differences between the two groups with respect to values, information sources, perceived importance of information sources, and the importance of heating system attributes in the decision-making.
3. Although there are no significant differences with respect to values between the two groups, the perception of which heating system is the most environmentally friendly differs significantly. The adopter group believes that wood pellet heating is the most environmentally friendly, whereas the non-adopter group perceives a heat pump to be the most environmentally friendly heating system, and wood pellet heating the least so. This result is in line with literatures (Black et al., 1985; Steg et al., 2005) in which ecological concern and norms were not strong/relevant for costly behavior (efficiency behavior).
4. The adopter group made significant shifts in heating systems. The shifts were away from wood stoves, fireplaces, and electric heating, to wood pellet heating. High fuel cost was the main motivation for the shift. On the other hand, there was no significant shift for the non-adopter group, for whom electric heating remains the dominant heating system. Nevertheless, fireplaces and wood stoves decreased, while electric and heat pump use increased.
5. The top three motivations by adopters for installing wood pellet heating are an aspiration for an environmentally friendly heating system, low operation costs, and an increase in electricity prices.
6. The perceived barriers against changing to wood pellet heating include economic, technical, and informational barriers. The six most perceived barriers in sequence are high installation cost, difficulties to refit the house, lack of information, fuel security issues, no one recommended it, lots of work, and high operating cost.
7. The subsidy required by the non-adopter group is 64% of the total installation cost. About 6% of the non-adopter group exhibits a willingness to install wood

pellet heating given the existing subsidy. This group, however, identifies difficulties refitting the house, a lack of information about wood pellet heating, and the anticipated required work connected to wood pellet heating as remaining barriers that prevent them from actually installing a wood pellet stove.

One limitation of the paper is that the survey did not cover questions regarding prerequisites for installation of a wood pellet heating (e.g. chimney) which are crucial aspects in adoption decision of wood pellet heating. Consequently, the analysis does not cover how the samples differ with respect to this aspect. However, the samples address owners of single-family residences, which are more likely to have chimneys than larger buildings. The lack of chimneys is relevant for a small minority of Norwegian single-family residences and is hence not expected to dominate the samples. The samples however may include those who do not have chimney and thus are unable to install wood pellet stoves.

4.2 Decision Process of Wood Pellet Heating³

While Paper 1 describes households' characteristics and perceptions, this study explores the process of choice in which a psychological model, which embeds basic and environmental values and perceptions of heating system performances, is applied. In other behavioral domains like transportation, recycling, water conservation, eco-labeled products, and fuel choice, the study of choice processes has been successfully applied to promote more sustainable behavior alternatives (e.g., Johns et al., 2009).

This paper particularly aims to reveal psychological factors underlying the adoption-decision of wood pellet heating in Norwegian households. It identifies relevant barriers and determinants of behavioral change, so that areas of potential intervention towards behavioral change can be revealed.

An interdisciplinary approach is applied to build a theoretical model. Three different perspectives are taken to explain adoption of wood pellet heating, one approach analyzing technology characteristics as the main driver, one analyzing psychological variables behind environmental behavior, and one analyzing values as predictors of pro-environmental choices. The integrated model proposed in the present study combines psychological factors (CADM), perceived wood pellet heating characteristics, and basic and ecological values in (retrospectively) explaining the installation of a wood pellet stove. Hypotheses are then derived from the integrated model. The integrated model (see Figure 4-1) is tested against the empirical data with a path analysis.

³Summarized from Paper 2, submitted for publication, 2010

Presented in Renewable Energy Research Conference, 7-8 June 2010, Trondheim, Norway

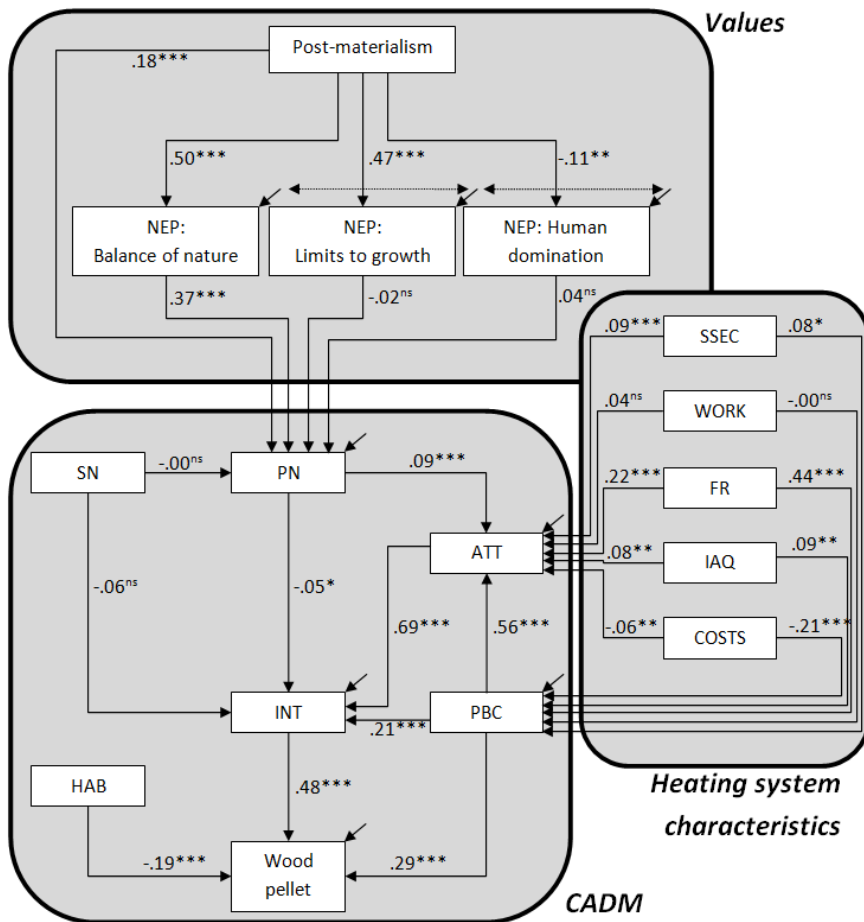

Figure 4-1 The tested combination of CADM, heating system characteristics, and basic and ecological values (post-materialism & NEP) to model the decision for wood pellet heating. The displayed numbers are standardized regression weights in a path analysis ($N=737$). Note: for abbreviations and model elaboration, see Paper 2.

Results from the path analysis provide empirical support for the proposed integrated model in which the model is able to explain 56% of variation. Wood pellet heating adoption seems mainly predicted by a deliberate decision process starting with the evaluation of heating system characteristics, mediated by attitudes and intentions. This finding is also supported by the finding from Paper 1 indicating that deliberation is the most employed decision strategy by adopters of wood pellet heating. Perceived behavioral control and habit, however, pose relevant barriers to the adoption process. The influence of norms and values is indirect and only minor in the given market conditions. Therefore, improvement of the subjective evaluation of the functional reliability related to wood pellet heating should have been given first priority, whereas focusing on values or norms should not be of highest priority at the moment. The small

but significant influence of habitual decision making indicates that reliance on electric heating may inhibit the adoption of wood pellet heating. As a result, presenting alternatives and increasing decisional involvement could be other promising strategies to reduce cognitive lock-in in decision-making.

However, some results are unexpected. Unexpected negative direct influence of personal norms on intention (parallel to the expected positive influence mediated by attitudes) seems to be a slight negative suppressor effect that should not be interpreted theoretically. Social norm lacks to have a significant influence on personal norm and intention which contradicts the results by Ek and Söderholm (2008) revealing that social influence affects individual consumption behavior in the green energy market. This is due to the unusual operationalization of social norms in the present study (estimated amount of influence).

Overall, the most important finding is that, besides the influences from intention, perceived behavioral control, attitudes, and habits, wood pellet adoption-decision is significantly determined by influences from personal norms and perceived heating system attributes.

4.3 Anticipated Future Heating System Choice⁴

Paper 1 indicates that a heat pump is the preferred future heating system of non-adopters (population sample), while wood pellet heating is preferred by adopters. However, heat pump is given more attention in the future by wood pellet adopters. It is therefore of interest to investigate rationales/motivations underlying the choice of one type of the heating system over another (i.e. electric heating, heat pump, wood pellet heating) as an anticipated future heating system by both adopter and non-adopter groups.

The third paper aims to identify factors motivating current users of electric heating system (non-adopters) to choose either air-to-air heat pump or wood pellet as a replacement heating system, as well as, to identify factors motivating wood pellet adopters to shift their main heating system away from wood pellet heating and back to either an electric heating or an air-to-air heat pump.

Multinomial Logistic Regression (MLR) is selected to deal with the 3-alternative categorical nature of the dependent variable. The independent variables of income, education, region, number of peers and decision strategy, are dummy coded using the highest category as a reference. The continuous independent variables include age and perceived importance of all heating system attributes. In comparison to previous heating system studies (see section 1.2), the novel contribution of this study is the inclusion of decision strategy as an explanatory variable of heating system choice.

⁴ Summarized from Paper 3, *Energy Policy* 2010: 38(7), 3744-3754

Presented in 5th International Conference on Industrial Ecology (ISIE) 2009, 21-24th June, Lisbon, Portugal

Findings of the analysis are divided into two parts as the following, determinants of anticipated future heating choice for population sample (reference: electric heating) and determinants of anticipated future heating choice for wood pellet adopters (reference: wood pellet heating) (see Table 4-1).

4.3.1 Determinants of anticipated future heating system choice for population sample

This section discusses the factors that might motivate the households from the population sample to choose either a heat pump or a wood pellet stove, as their future heating system, and possible interventions derived from these results.

Table 4-1 Relationships between hypothesized variables and future anticipated choice of a heating system

Factor	Variable	Population sample ^a		Wood pellet adopters ^b	
		Heat pump	Wood pellet	Electric heating	Heat pump
Socio-demographic	Age	↓ ^(s)	↓ ^(s)	↑ ^(s)	0
	Income level (1-3)	0	2 ^(ms)	2 ^(s)	0
	Education level (1-3)	0	2 ^(ms)	0	0
	Region (1-5)	0	5 ^(s)	5 ^(ms)	5 ^(s)
Communication	Number of peers (1-6)	0	0	0	1,2 ^(s) ;3,4 ^(ms)
Heating system attribute	Functional reliability	0	0	0	↑ ^(s)
	Indoor air quality	↓ ^(s)	0	↓ ^(ms)	↓ ^(s)
	Investment cost	0	0	0	0
	Operation cost	0	↓ ^(ms)	0	0
	Upkeep work	0	0	↓ ^(s)	0
	Fuel supply security	↑ ^(ms)	0	0	↓ ^(s)
Decision strategy	Decision strategy (1-4)	4 ^(s)	0	0	4 ^(s)

Notes: ^aReference: Electric heating; ^bReference: Wood pellet heating

↑=the higher the variable value, the more likely to choose heat pump/wood pellet than reference;

↓=the lower the variable value, the more likely to choose heat pump/wood pellet than reference;

^(s) indicates significant; ^(ms) indicates marginal significant, at the level of 0.05

Income level 1)Less than NOK 250 000, 2)NOK 250 001 – NOK 550 000, 3)More than NOK 550 000; **Education level** 1)Elementary school, 2)High school, 3)University of higher; **Region** 1)East 2)South 3)West 4)Mid-Norway 5)North; **Number of peers** 1) 0, 2) 1-5, 3) 6-10, 4)11-15, 5)16-20, 6) more than 20; **Decision strategy** 1)Repetition, 2)Deliberation, 3)Imitation, 4)Social comparison

Age is statistically significant for the choice of electric heating over a heat pump, as well as, for the choice of a wood pellet stove. This result is also in line with the results of a Swedish pellet diffusion study conducted by Mahapatra and Gustavsson (2008)

revealing that older people find it more difficult to change their behavior as they have become accustomed to their existing heating system, and therefore, will be less likely to install a new kind of heating system. This might be taken as an indication that younger people are more open to considering new technologies.

The choice of heat pump by this group is significantly influenced by age and perceived importance of indoor air quality in decision-making. Indoor air quality is implied to be a disadvantage related to the use of a heat pump, because households who consider indoor air quality to be especially important are unlikely to choose this kind of heating system. The problem could be associated with the assumed dust recirculation caused by a heat pump. Bjørnstad et al. (2005) identified dust on the filter of the inside of a heat pump as the second highest problem rated by households. Nevertheless, this problem is not necessarily due to technical shortcomings of the heat pump as it is rather part of a learning process to recognize that for an optimal performance the various components of a heat pump need regular inspection and maintenance/cleaning (Bjørnstad et al., 2005). Providing information on heat pumps and facilitating a faster learning process is important so that the problems that are raised in the early marketing stage of a new technology are not perceived as technological drawbacks. Decision strategy is a significant factor, and respondents use repetition over social comparison to choose electric heating over a heat pump. This result suggests that they are satisfied with their existing heating system and will repeat this choice in the future. The result suggests, on the other hand, that those who are likely to choose a heat pump perform a social comparison; a reasoned- and socially-determined decision. Their use of the social comparison strategy could reflect their dissatisfaction with their current heating systems, and therefore they search for an alternative. Because a heat pump is considered a new technology, uncertainty is relatively high. This motivates households to compare their choices with those of other households. Applying this decision strategy, the examined households should use other households in their social network as a means to acquire information. As purchasing a new heating system involves a large investment, households are forced to elaborate on alternatives, investing more cognitive effort in the decision process. From the interventionist perspective, if one wants to drive the uptake of heat pumps, one possible motivation for considering a change could be media campaigns or providing key actors in the social networks with tailored information fitting the need of the target group. The facts that the trade organization of heat pumps is more active than that of wood pellet heating (Bjørnstad et al., 2005), and that there has been active promotion of heat pumps as an alternative heating system may explain that heat pumps are more adopted than wood pellet heating.

The choice of wood pellet heating by this group is significantly influenced by age and region. Those who reside in the West of Norway are more likely than those in the North to choose electric heating rather than a wood pellet stove. This result resonates with the findings of a previous study of heat pump and wood pellet adoption that was conducted after the subsidy for households was introduced in 2003 (Bjørnstad et al.,

2005), showing that heat pumps were mostly adopted in western Norway, whereas wood pellet stoves were adopted in Hedmark, Oppland, and Nord-Trøndelag. This could be explained partially by the milder climate in the west coast area that makes electric heating a more practical heating option. The fact that Rogaland, alongside Oslo and Akershus, is among the regions with the highest average household income in Norway (Statistics Norway, 2010) is consistent with the findings of Nesbakken (1998) who confirmed that the higher the income, the higher the probability to choose electric heating over wood-based heating.

It is worth noting that the number of households that choose wood pellet heating is quite small (only 8% of the population sample's respondents). Most of them prefer heat pumps, followed by electric heating. This means that the results for wood pellet heating must be interpreted with care. This also conveys low observability of wood pellet heating in this sample, meaning that wood pellet heating might not be recognized by most households due to its small market share. This was also the case for solar energy technology (Labay and Kinnear, 1981). To increase the observability of wood pellet stoves, existing networks of wood pellet users must be supported. As wood pellet users (see Paper 1) communicate with other households more than others do, they may serve as nodes in their social networks or at least are part of a well functioning social network. As such this group could offer advice to potential consumers and create awareness when they are at the point of making a real investment decision; this would ensure that the pellet option is at least considered when deciding about the future heating system. This network forms the vehicle through which the advantages of wood pellet heating are communicated. Studies indicated that communication with adopters could increase the probability of adoption (Frambach, 1993; Midgley et al., 1992). It is essential therefore that policymakers have a thorough understanding of those households that are in influential positions.

4.3.2 Determinants of anticipated future heating system choice for wood pellet sample

This section introduces the influential factors that explain when wood pellet adopters continue to keep wood pellet heating as their main heating system or switch to either electric heating or a heat pump in the future.

The choice of electric heating by this group is significantly influenced by age, income level, and perceived importance of upkeep work. Those who currently use wood pellet heating are more likely to choose electric heating rather than continuing to use wood pellet stoves as they grow older. This is consistent with the results that electric heating is preferred by older people due to the fact that electric heating requires less work compared to the wood pellet stove, e.g. loading/unloading pellets, cleaning the stove, etc. This result could also be reflected from the fact that those who perceived upkeep work less important have greater probability of choosing wood pellet heating.

Income once again shows significant influence on the choice of electric heating. Those with a high income prefer electric heating, whereas those with a medium income prefer wood pellet stoves. The same result has also been shown for the population sample discussed above.

The choice of heat pump by this group is significantly influenced by region, number of peers with whom they communicate about heating, perceived importance of functional reliability, indoor air quality, and fuel supply security, as well as decision strategy. Region has a significant impact on the choice of a heat pump and a marginally significant impact on the choice of electric heating. Those who reside in the East and those who live in the South are more likely than those who live in the North to choose wood pellet stoves over electric heating or a heat pump. This could be due to the fact that the biggest wood pellet producer in Norway is located in Hedmark. The short distance between producer and consumers results in an easy and reliable access to wood pellets for households in the East and in the South. The result indicates that the fuel supply plays an important role to heating system adoption in Norway. This result is supported by the evidence that one main reason of the electric heating lock-in is easy access, and fuel price fluctuation was proven to be a significant influence on the shift of heating systems (Brottemsmo, 1994). The results indicate that those who recommended a heating system to more than 20 peers recommend wood pellet heating, and are most likely to keep on using wood pellet heating. This means that those who plan to continue using wood pellet heating in the future seem to show more opinion leadership than those who want to change to heat pumps, which is in line with the result from Paper 1. However, it has to be repeated that recommendation against a heating system was not recorded in this study, so it might be possible that wood pellet users dissatisfied with wood pellet heating have opinion leadership in the negative direction. Recommendation behavior reflects people's satisfaction/dissatisfaction with their current heating system, i.e., households will not recommend a heating system if they are not satisfied with it. The fact that wood pellet heating adoption is low indicates that recommendation by adopters is not enough to enhance the adoption rate. The relative advantages of wood pellet stoves should be made more visible before choosing a communication based strategy to enhance wood pellet adoption. Once the technology-related factors of wood pellet heating are perceived as advantageous, the communication behavior of wood pellet users might contribute to further adoption. The improvement of the subjective evaluation of the system attributes of wood pellet stoves should be the main concern for increasing wood pellet adoption, similar to the result from Paper 2. The results also suggest that those who are most likely to continue choosing the wood pellet stove apply the decision process of repetition rather than social comparison. This behavior reflects their satisfaction with the wood pellet stove. Factors that contribute to the satisfaction and dissatisfaction with wood pellet stoves merit further study to identify the areas for improvement. Alternatively, another possible strategy to promote wood pellet stoves would be to give positive

reinforcement/rewards to those who repeat their choice. Rewards could be quantity discounts for the purchase of wood pellets.

With the respect of decision strategy, the acquisition of a heat pump is dominated by a strategy of social comparison can be found in both samples. Thus, the purchase of a heat pump is influenced by the market share of this technology can be generalized. This finding is actually in line with the results of a previous study of heat pump adoption confirming that recommendation from other users is the most important motivation to install a heat pump (Bjørnstad et al., 2005). Social influence is strong in the decision for a heat pump but this does not imply irrationality in decision making. The strategy of social comparison most likely supports a rational decision, but the information needed for decision making is acquired from the social network instead of other sources, which is in line with the finding of Paper 1 showing that family/friends are the most important information sources for non-adopters, who typically selects a heat pump as an anticipated future heating system. The consistent result of social comparisons dominating the decision for a heat pump gives an indication that this aspect of a household's decision making process should not be ignored by policy makers.

Contrary to heat pump market, there is not yet a sufficient number of people using wood pellet heating to form a social reference group, a change that is called a 'chasm' in the diffusion literature (Moore, 1999). Once a critical number of people using a product is reached, market behavior often changes and other factors drive the adoption process. The market for wood pellets seems still to be in its early stage before this chasm.

It is worth noting that about 43% of current wood pellet users prefer heat pumps as their main heating system in the future. Only about half of the wood pellet users continue with the choice of wood pellet heating. The result shows that those who are dissatisfied with their wood pellet stove are likely to compare their existing heating system with that preferred by most members of their social network (which would usually be a heat pump). The dissatisfaction could be due to bad experience with the wood pellet stove or an aging population. As result identifying that those who perceived functional reliability more important are unlikely to continue using wood pellet heating, improving functional reliability should be a priority.

Even though investment and operational cost as heating system characteristics fail to be significant aspects of the decisional process, there is an interesting finding showing that those with high level income prefer the use of electric heating although the investment in wood pellet stoves should be affordable. This raises the question why people who are able to afford wood pellet stoves prefer to choose electric heating. One possible explanation could be that electric heating appears to be the most convenient heating source as almost no maintenance work is required. Some households, for example older people, could perceive the necessary work related to the use of a wood pellet stove too difficult because of physical limitations. Another possible explanation is that these households value their time and time spent on maintaining and operating a

wood pellet stove might be considered wasted. Finally, people with high incomes could be less affected by fluctuating electricity prices on the market and therefore do not perceive this advantage of wood pellet stoves as much as people with less income.

Interestingly, the importance of investment cost was found to be statistically insignificant in both the population sample and the wood pellet sample. However, including income as a variable has reduced the explanatory power of investment costs because income and the importance of investment costs are related to each other. Eliminating income from the regression equation to test this assumption resulted in a significant impact of investment cost.

In addition to the limitations that have been discussed in the paper, it is also worth mentioning that the decision strategy is actually driven by uncertainty of decision outcome and level of need's satisfaction which were not captured in the survey. This implies that a household may engage to various decision strategies depending on the situations influencing the drivers, rather than one decision strategy at all times. However, the survey asked the respondents to select one of the decision strategies, which is the most representative strategy when it comes to decision about a heating system.

Agent-Based Modeling and Simulation

This chapter presents the experimentation of ABM application to explore the mechanism of heterogeneous household decision-making which results in the cumulative adoption (diffusion) of various heating systems. The model is specifically designed to identify potential interventions towards increased adoption of wood pellet heating. This chapter comprises the summary of the methodological proposal coupling agent-based modeling with empirical research (section 5.1), a description of agent-based model (section 5.2), model implementation (section 5.3), model verification, calibration and validation (section 5.4), effect of social network structure (section 5.5), scenario analysis exploring potential interventions favoring further diffusion of wood pellet heating in Norway (section 5.6), and model limitations (section 5.7). The details of each can be found in Paper 4, 5, and 6 (see Appendix B).

5.1 Methodological Proposal: Coupling Agent-Based Modeling with Empirical Research⁵

Most simulation models are often questioned to what extent the implemented formulations are validly describing decision-making as they normally rely on simple behavioral models that are not empirically-based or validated. The research presented here is based on a methodological proposal of coupling agent-based simulation and quantitative empirical research. This section addresses how to model the decision-making of agents in an ABM, aiming at modeling the decision process in a manner that is grounded in theoretical and empirical decision research.

The empirical analysis has contributed to the investigation of empirical facts of Norwegian households, i.e., important factors and their implications in adoption-decision of heating system. Based on the insights gained from the analysis and theoretical considerations, the simulation model is developed, taking also into account the self-described perceptions on heating system attributes, and the self-described attitudes of decision strategy, communication habit, and psychological aspects in decision-making. Simulations are carried out to explore potential interventions for wood pellet heating uptake, and to compare the results to literatures and empirical findings.

⁵ Summarized from Paper 4, submitted for publication, 2010

Presented in The European Association for the Study of Science and Technology Conference 2010 (EASST010), 2-4th September, Trento, Italy

The proposed methodology of coupling empirical research and computational modeling of technology adoption and diffusion basically consists of the following.

1. Literature review on consumer behavior toward technology adoption.
2. Construction of a conceptual model based on the theoretical considerations and empirical findings from the literatures.
3. An empirical survey to parameterize the model and to validate the model (micro-level). The first three steps allow a more representative decision-making model of households in the sense that it captures technology-related and psychological factors, and follows empirically grounded behavioral principles.
4. Implementation of the model in an ABM and simulation in which a case study of heating system adoption and diffusion in Norway is served as an illustration of the application of this methodological proposal.

The proposed methodology therefore allows the model to gain a strong theoretical and empirical supports, so that a better model can be attained.

5.2 Agent-Based Model⁶

5.2.1 Agents

An agent is defined as a decision-making entity in the agent-based model. Given that the heating system decision in Norway is predominantly made at the household level (supported by the finding from Paper 1), households are therefore selected as agents in this model. As a result, an agent within this model represents one specific household drawn from the population sample (N=270). Although the households used in the model do not capture all the Norwegian households, age and regional distributions of the sample are considered to be representative since the statistical analysis indicates no significant differences from those of the overall Norwegian population.

Households are characterized with respect to their geographical location, household group, decision strategy, degree of social influence in decision-making, and the number of peers to whom households communicate about their heating needs. Rogers (2003) recognizes that consumers differ when it comes to their attitudes toward technology characteristics. Subsequently, the model implement household group as a mediating variable between perceived heating system attributes and attitudes, and is assumed to be constant through the simulation. A cluster analysis based on the variables income and basic value orientation results in three groups, whereby a significant difference among clusters with respect to income level and basic values is identified (Figure 5-1). Household Group 1 represents households with a low/medium

⁶ Summarized from Paper 4, submitted for publication, 2010

Presented in The European Association for the Study of Science and Technology Conference 2010 (EASST010), 2-4th September, Trento, Italy

income, but post-materialistic values; Household Group 2 represents those with a medium/high income with a medium level of materialism, whereas Household Group 3 represents those with a low/medium income and materialistic values. Statistical analysis using ANOVA indicates that the groups are significantly different with respect to age between Group 1 and 2, as well as, Group 2 and 3 ($F(2,250) = 9.125, p < 0.001$) and personal norms between Group 1 and 2 ($F(2,260) = 4.121, p < 0.05$).

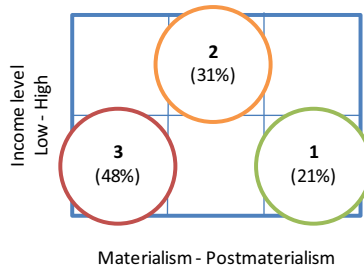

Figure 5-1 Household groups based on cluster analysis

The households are placed based on their real geographical location in Norway, which has a total area of 385,252 km² and 4.8 million inhabitants (Statistics Norway, 2010). The southern and western coasts of Norway are more populated, which is reflected in our agent population (see Figure 5-2).

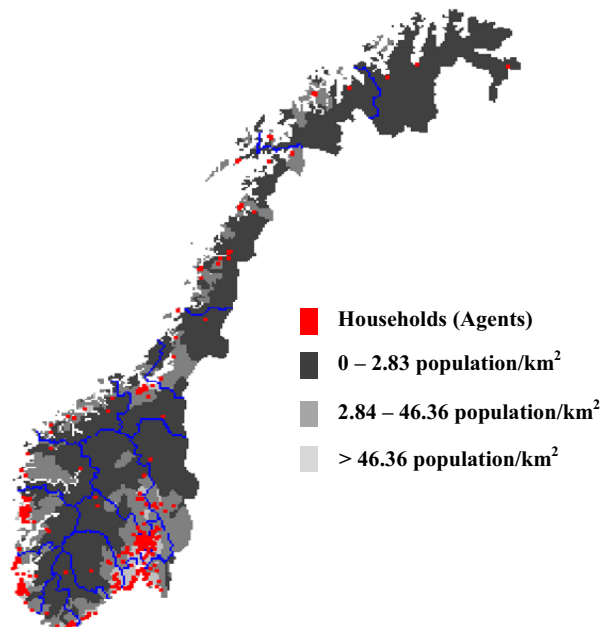

Figure 5-2 Household agents located on a map of Norway

The household attributes along with their range are derived from empirical survey and listed in Table 5-1. Due to the fact that the decision strategy employed by household

is not always the same because they are exposed to different situations from time to time, instead of assigning households to one fixed decision strategy, each household selected their decision strategy at each time step with the choice probabilities acquired from the survey. The model is thus not fully deterministic. Furthermore, the number and location of households is held constant throughout the simulation.

Table 5-1 Households' specific attributes

Households' specific attributes	Initialization and Allowable Ranges
Geographical location	Real geographical location presented in a grid
Household group	Each household is assigned to one of the three household groups acquired from the survey at the start of simulation 1: Low-medium income and post-materialism 2: Medium-high income and medium materialism 3: Low-medium income and materialism
Decision strategy	Each household select one of decision strategies randomly each time-step with the probabilities acquired from empirical survey: 1 = Repetition (23.5%) 2 = Deliberation (59.1%) 3 = Imitation (2.1%) 4 = Social comparison (15.3%)
Degree of social influence when making decision	Determined at the start of simulation Range of 0 – 1 with an interval of 0.1
Number of peers	Determined at the start of simulation Range of 0 – 16

5.2.2 Heating Systems

The household agents decide upon one of the heating system options, i.e., direct electric heating (the standard technology), an individual wood pellet stove, or heat pump, which compete against each other. Most Norwegian households, in fact, utilize more than one type of heating system, but the model only simulates the main, or most frequently used, heating system. Each heating system studied is characterized by a set of attributes as identified by Mahapatra and Gustavsson (2008); perceived fuel price stability, perceived indoor air quality, perceived functional reliability, perceived total cost, and perceived upkeep work. All of the attributes are user-settable parameters in which the initial values are however acquired from the empirical survey (see Table 5-2).

Policy designers can use the initial values as references and modify them to see the effect resulting from the change. The model allows policy designers to intervene in different parts of the system. Because the model also incorporates personal norms (see Figure 5-3), policy designers are able to design a variety of programs ranging from soft interventions (e.g., influencing household beliefs through promotion), to either

regulation (fixed fuel prices or installation subsidies) or technical intervention (functional reliability development or automation).

Table 5-2 Mean values of the subjective perception on heating system attributes derived from the survey

Heating System Attributes	Electric Heating	Heat Pump	Wood Pellet Heating
Fuel Price Stability ^a	0.33	0.49	0.45
Indoor Air Quality ^b	0.52	0.67	0.57
Functional Reliability ^c	0.85	0.72	0.61
Total Cost (investment and operation costs) ^d	0.48	0.43	0.56
Required Work ^e	0.11	0.32	0.57

Note: 1) data represent mean values rated by households using a 7-point Likert scale, which was then re-coded into a numeric scale from 0 (minimum) to 1 (maximum). 2) The higher value, ^athe more stable, ^bthe better quality, ^cthe more reliable, ^dthe higher cost, ^ethe more required work

5.2.3 Decision-Making Process

In this study, the decision-making of various households is explicitly modeled. The integrated model which has been developed in Paper 2 could not directly be adopted in this simulation because the model is considered too complex to be implemented in the simulation. The developed model has however indicated the significance of personal norms and perceived heating system attributes which will then be implemented in the decision-making process of the agent-based model. Based on the theoretical considerations from various theories: Diffusion of innovation (Rogers, 2003), theory of planned behavior (Ajzen, 1991), utility theory (Fishburn, 1970), and meta-theory of decision strategy (Jager, 2000), and empirical findings, a model for adoption-decision to be implemented in an ABM is constructed and displayed in Figure 5-3 (see Paper 4 for the detail construction of the model).

Depending on the employed decision strategy, household agents follow various decision-making processes specified in the adoption-decision model (see Figure 5-3). Consequently, households are employing different types of decision strategies. Those who apply repetition adopt the same heating system as previously done without any other cognitive process involved; those who apply imitation adopt the heating system primarily used by their peers (neighboring households and random-selected households); those who deliberate, such as decision strategies of deliberation and social comparison, apply utility maximization to identify the system that suits best. Within this utility maximization, variables described in the theory of planned behavior and in diffusion of innovation are implemented to represent the mechanisms of intention formation and attribute selection and evaluation. To incorporate social influence within a decision, the utility function combines individual intention and social interaction to take into account both internal and external factors in household decisions. A utility-based model seeks to describe choices, and the choice is made based on its highest

utility. The utility calculation is based on the adoption-decision model described further by the following equations.

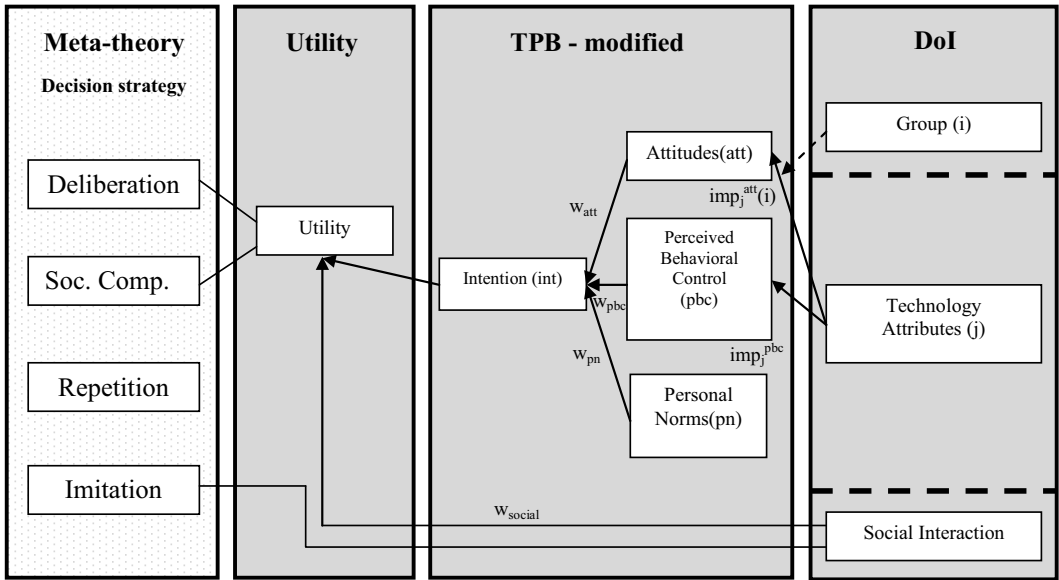

Figure 5-3 Adoption-Decision Model

$$att = \sum_j imp_j^{att}(i) * value_j \quad (1)$$

$$pbc = \sum_j imp_j^{pbc} * value_j \quad (2)$$

$$int = w_{att} * att + w_{pbc} * pbc + w_{pn} * pn \quad (3)$$

$$\%peers = \text{peers with technology type in question} / \text{total peers} \quad (4)$$

$$utility = int * (1 - w_{social}(k)) + \%peers * w_{social}(k) \quad (5)$$

where:

- i is household group
- j is technology attribute
- k is a household
- att is attitude toward a technology
- $imp_j^{att}(i)$ is the importance of technology attribute j of group i to attitude formation
- $value_j$ is perceived technology attribute j
- pbc is perceived behavioral control of a technology
- imp_j^{pbc} is the importance of technology attribute j to pbc formation
- int is intention toward a technology
- pn is personal norms
- w_{att} is the weight of attitude in int formation
- w_{pbc} is the weight of pbc control in int formation
- w_{pn} is the weight of pn in int formation
- $\%peers$ is the percentage of peers using technology in question
- utility is the utility of a technology
- $w_{social}(k)$ is the weight of social influence in decision-making of household k

Table 5-3 Weights of components in the adoption-decision model for the heating system adoption and diffusion in Norway

Components	Electric Heating	Heat Pump	Wood Pellet Heating
Preference ← ATT	0.699***	0.737***	0.707***
Preference ← PBC	0.350***	0.173***	0 (n.s.)
Preference ← PN	-0.058~	0.065~	-0.065~
Household Group 1			
PBC ← Fuel Price Stability	0.102~	0 (n.s.)	0.304***
PBC ← Indoor Air Quality	0.133**	0.128~	0 (n.s.)
PBC ← Functional Reliability	0.808***	0.904***	0.574***
PBC ← Total Cost	0 (n.s.)	0 (n.s.)	0 (n.s.)
PBC ← Required Work	0 (n.s.)	0 (n.s.)	0 (n.s.)
Household Group 2			
ATT ← Fuel Price Stability	0 (n.s.)	0 (n.s.)	0.406*
ATT ← Indoor Air Quality	0.507***	0 (n.s.)	0 (n.s.)
ATT ← Functional Reliability	0.402***	0.764***	0.639***
ATT ← Total Cost	-0.275*	0 (n.s.)	0 (n.s.)
ATT ← Required Work	0 (n.s.)	0 (n.s.)	0 (n.s.)
Household Group 3			
ATT ← Fuel Price Stability	0.369***	0 (n.s.)	0 (n.s.)
ATT ← Indoor Air Quality	0.284***	0.331***	0 (n.s.)
ATT ← Functional Reliability	0.395***	0.694***	0.568***
ATT ← Total Cost	-0.156~	0 (n.s.)	0 (n.s.)
ATT ← Required Work	0 (n.s.)	0 (n.s.)	0 (n.s.)
Household Group 3			
ATT ← Fuel Price Stability	0 (n.s.)	0 (n.s.)	0 (n.s.)
ATT ← Indoor Air Quality	0.523***	0.458*	0 (n.s.)
ATT ← Functional Reliability	0 (n.s.)	0.437~	0.573***
ATT ← Total Cost	0 (n.s.)	0 (n.s.)	-0.338*
ATT ← Required Work	-0.259~	-0.371*	-0.298*

*** $p < .001$; ** $p < .01$; * $p < .05$; ~ $p < 0.1$; n.s. = not significant

Note: the insignificant regression weights are set to zero in the model

The trigger for decision-making is represented by the variable “replacement time,” which symbolizes the time period needed to replace a heating system. The replacement could be due to a breakdown which could be assumed to be related to a heating system’s lifetime, or could be due to external events such as high fuel costs, subsidies or aggressive advertisements that may persuade households to change their heating system before its lifespan has been reached. Based on the results of the empirical survey, approximately 70% of the respondents revealed that a breakdown is the most important motivation for replacing a heating system, with high fuel costs being the second most important reason (see Paper 1). An average replacement time of 20 years, estimated from the survey, corresponds to the replacement time due to a system being out of order, which is subsequently implemented as the replacement time before the electricity crisis in the winter of 2002-2003. A previous study of heating systems in Norway provided evidence that high oil prices in 1986 were responsible for a shift from liquid fuel to electric heating (Brottemsmo, 1994), meaning that high fuel costs can trigger a

replacement. This model therefore assumes that replacements due to both broken equipment and high electricity costs are the main drivers of decision making. The latter is not covered in the survey, so the replacement time due to the electricity price peaks needs to be estimated (see section 5.4 and Figure 5-5 for the estimation).

5.3 Implementation

The described agent-based model is implemented using a Repast Java platform (Repast, 2009) which is run in an Eclipse environment (Eclipse, 2009). The simulation start represents the year of 2001 when all the households in the simulation had the standard technology, i.e. an electric heating system, because, according to Statistics Norway (2006), the fractions of installed heat pump and wood pellet heating in 2001 were close to 0. A simulation time period from 2001 to 2008 is used for the model calibration and validation. The output from 2008 is then used as an input for scenario analysis.

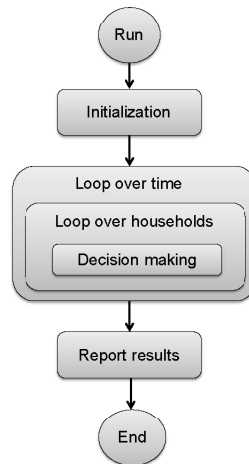

Figure 5-4 Simulation flowchart

Since the model contains random processes, e.g., when generating random interaction in a small-world routine, multiple runs (replications) of simulations using identical parameters and initial conditions are necessary to determine whether the results of a simulation run are representative. Following Garcia (2005), 30 replications are performed for a single simulation result. Figure 5-4 displays a simulation flowchart for a single run. During initialization, all the data acquired from the survey to be used in the simulation is imported and the model is then initialized to represent conditions in 2001. The decision-making box implementing the decision-making process is run over all households yielding a result for a single time step. Nonetheless, aggregated and spatial results are reported for every time step, although the final result is acquired after the desired simulation time is reached.

There are two ways representing the simulation results, either through averaging or by selecting the most frequent result out of multiple runs/replications (Gilbert, 2008). Both methods are implemented in this study in which the first is to present aggregated results, and the latter is to present spatial results.

5.4 Verification, Calibration, and Validation

Verification refers to determining whether the programming implementation of the conceptual model is correct. During the implementation work, the intermediate results are shown to see whether there are errors in the program. The program also goes through an examination under extreme conditions, e.g., when perceived heating system attributes of heat pump and wood pellet heating are assigned to zero, the result shows no adoption of these two heating systems. Last but not least, the program is also verified by an independent third-party programmer.

Calibration is concerned with setting model structure and parameter values so that it accurately reflect a real-world situation. According to Fagiolo et al. (2006), an agent-based model could be calibrated either directly or indirectly; direct calibration requires that the empirical data are used as values for model parameters or initial conditions, while indirect calibration requires a number of calibration runs by varying the model parameters so that the output is the same as that of the empirical data. This study operated both direct and indirect calibrations. Direct calibration is used in the sense that empirical data from the survey is used as the initial values of model parameters (see Table 5-2 and Table 5-3). In contrast, indirect calibration is used to derive a replacement time after the first electric crisis in the winter of 2002-2003. Bjørnstad (2005) provides information that can be used to estimate replacement time after subsidy in 2003. Replacement times of 7 and 10 years are derived and simulation runs for these two replacement times are then conducted.

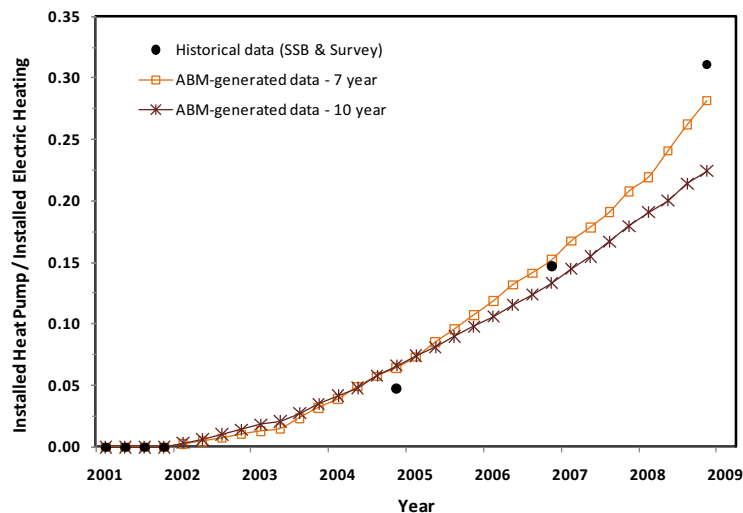

Figure 5-5 Model calibration for replacement time after electricity crisis

Figure 5-5 shows that a replacement time of 7 years yielded the best fit to historical data from both Statistics Norway (2006) and the survey. The replacement time of 7 years is therefore applied to represent the replacement time after the crises.

Validation in this study attempts to confirm that the model behaves significantly similarly to that of the real-world system studied because the usefulness of a model is predicated on its ability to link observable patterns of behavior of a system to structures on the micro-level (Qudrat-Ullah, 2005). Moreover, validation for an agent-based model could be investigated in two features: structural validity and behavioral validation. The structural validity comprises theoretical and empirical structural validation. The theoretical structural validation can be achieved by adopting existing models (Forrester and Senge, 1980), whereas the empirical structural validation can be achieved by using available knowledge of a real system when characterizing the causal relationships within the model (Qudrat-Ullah, 2005). Table 5-4 reviews the structural validity of the model.

Table 5-4 Structural validity

Structural validity	Remarks
Boundary adequacy	Consistent with the purpose of the model, decision-making is generated endogenously
Structure validation	Adopted structure from existing models: Integration of psychological model and technology attributes (Jeyaraj et al. 2006; Schwarz and Ernst, 2009) Meta-theory and utility theory (Janssen and Jager, 2002; Schwoon, 2006)
Parameters	All parameter values are derived from the survey and historical data, no guess is made

Behavioral validation examines the extent of the outcome that the model behavior reproduces in a real system which is acquired from independent data. With respect to behavior validation, the validation of the model is made on both the macro- and micro-level. Figure 5-6 displays agent-based simulation generated data for a heat pump versus independent historical data (Norsk Varmepumpeforening, 2006). The results for wood pellet heating are not shown in the figure because the adopted wood pellet heating obtained from the simulation result is quite small (0.16%) in 2006 and shows no further adoption, which reflects the actual system of adopted wood pellet heating which was 0.3% in 2006 (Statistics Norway, 2006) and that the market have been stagnant. In the mean time, the market for heat pumps has continuously increased despite the ceasing of subsidies from 2006. Unfortunately, the validation for electric heating cannot be performed due to the unavailability of independent data. The simulation result implies that the model is reasonably able to reproduce the independent data at the macro-level.

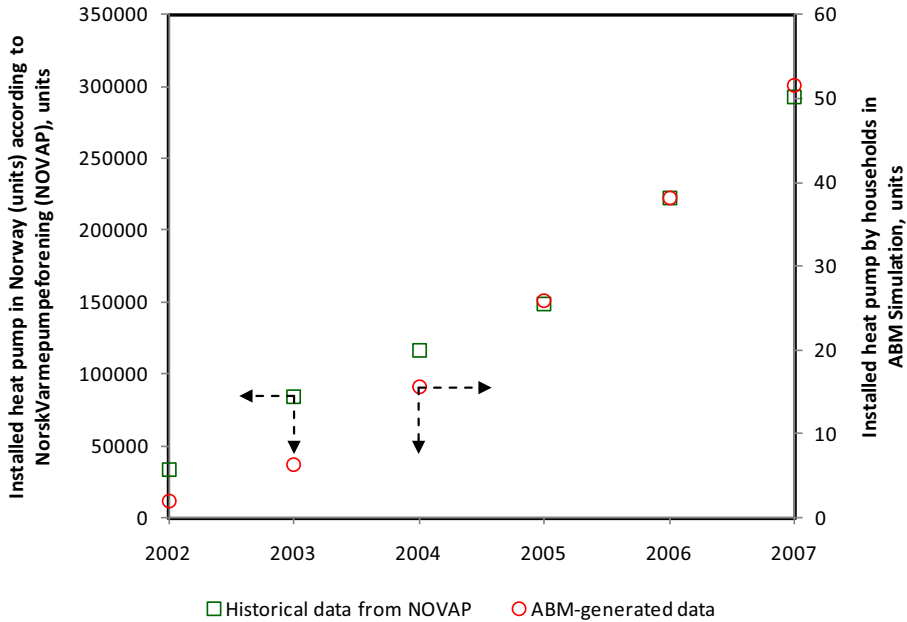

Figure 5-6 Macro-level validation for heat pump

With respect to micro validation, the model simulated adopted heating systems for different household groups. As independent data is not available for this level, data from the survey not utilized in parameterization and calibration of the model is used. The agent-based generated data is compared to the survey data in which the respondents were asked to indicate their main heating system at the time when the survey was conducted.

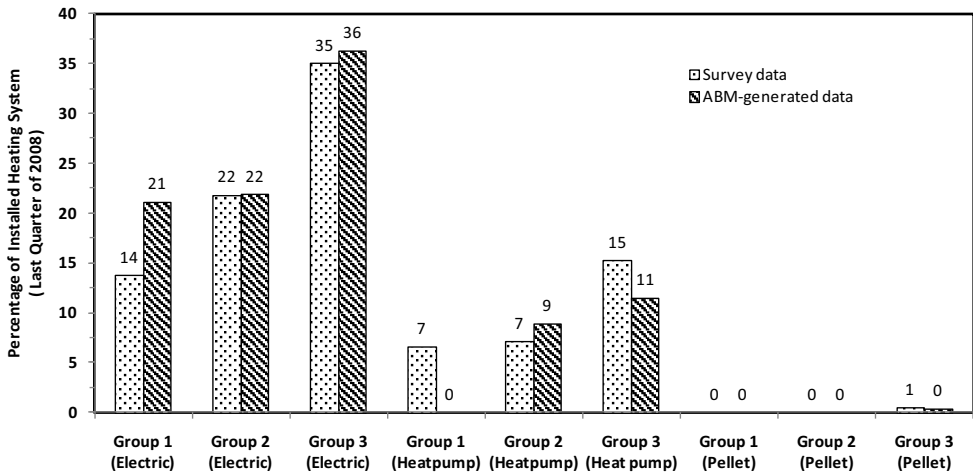

Figure 5-7 Micro-level validation (based on the most frequent single run produced from 30 simulation runs)

Figure 5-7 displays the percentage of adopted heating systems for different household groups over the last quarter of 2008. Chi² tests are conducted based on the assumption that the ABM-generated data produces the same results as the historical data for different groups and heating system types. The tests indicate no significant differences between both data except for Group 1 and heat pump. The model is therefore able to replicate the actual system for Groups 2 and 3, as well as, for electric heating and wood pellet heating. Furthermore, the model and the simulation results have been communicated to ENOVA, regarded as a potential user, that has provided subsidies for wood pellet heating for Norwegian households.

5.5 Structure of Social Network⁷

Households reside in a social network in which they communicate with and/or observe the behavior of other households. The interaction thus has an influence on the decision. Midgley et al. (1991) were able to document a substantial effect of the modeled network structure on the diffusion process. This sub-section thus demonstrates the effect of various structures of social network on the diffusion patterns.

There are different approaches to model a social network in an agent-based simulation: One type of network structure is based on spatial proximity, such as in a Moore network (Weisstein, 2010a) and Von Neumann network (Weisstein, 2010b). Another network, known as random network in which each household communicates with other households at random, was firstly introduced by Erdős and Rényi (1959). Since real networks are unlikely to be purely random, Watts and Strogatz (1998) have introduced regular network ‘rewiring’, a so-called small-world network. The algorithm difference among those three approaches is presented in Figure 5-8.

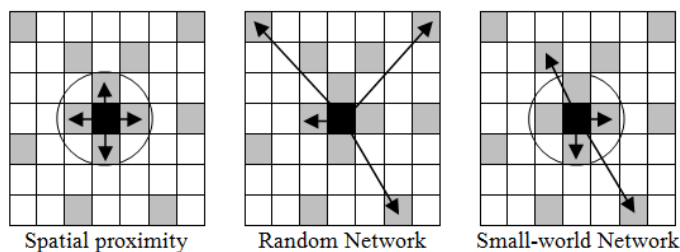

Figure 5-8 Different social network structures with 4 neighbors

Because the survey did not capture the structure of social network, a sensitivity analysis of different structures of the social network on the diffusion rate is conducted. With respect to small-world network, in order to enable the social network of the model to have the attributes of a small-world effect, the model sets a rule that each household interacts with its neighbors due to a spatial proximity acquired by using a “radius” (see

⁷ Summarized from Paper 5, presented and published in Proceedings of World Congress on Social Simulation (WCSS) 2010, 6-9th September, Kassel, Germany

Figure 5-8) and interacts with the rest of the population randomly. Spatial component of the small-world network may express structural relationships (i.e., nearby neighbors), while random component of the small-world network may express relational relationships (i.e., relatives, families). The number of a household's neighbors is determined by the survey.

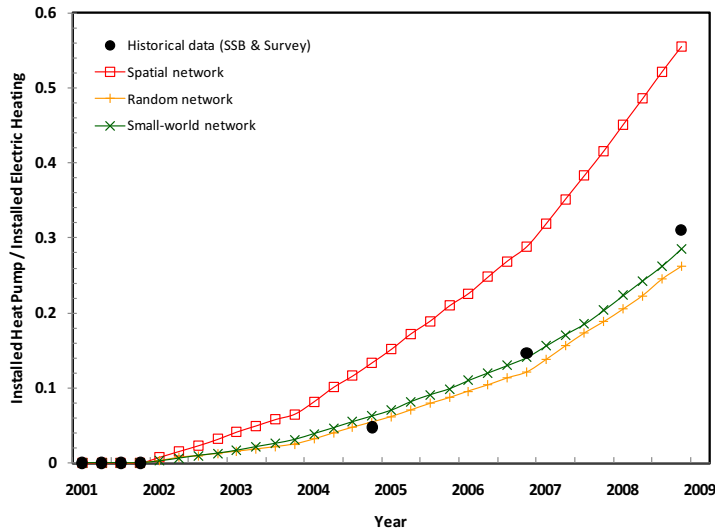

Figure 5-9 Influence of various structure of social network on the diffusion pattern

The result suggests that the small-world network structure offers the best representation of the household social network structure within the context of heating system adoption and diffusion (see Figure 5-9). Statistical analysis indicates however that the difference between small-world and random network is not significant ($Chi^2 = 0.034$; $df = 32$; $p = 1$).

5.6 Scenario Analysis⁸

This section aims to explore potential interventions for the initialization of wood pellet heating uptake in Norway. The policies utilize following levers: perceived heating system attributes and personal norms, wherein the initial values of these variables are derived from the empirical survey for the base model. The possible interventions related to the attributes of heating systems could be in the form of regulation (e.g., fixed fuel prices of wood pellet heating), financial aid (e.g., installation subsidies) and/or technical development (e.g., reliability or automation). Interventions focusing on influencing household beliefs through promotion, education, or actor-role, could also be simulated through personal norms. Three scenarios are presented here to illustrate the diffusion

⁸ Summarized from Paper 6, accepted in *Energy Policy* 2011
Presented in Renewable Energy Research Conference 2010, 7-8 June, Trondheim, Norway

pattern of wood pellet heating resulting from different policy interventions targeted at households.

Table 5-5 The scenarios - The parameter setting for policy interventions

Variables	Base Model	Same as BAT (S1)	Individual Development (S2a) versus Simultaneous Development (S2b)		Soft intervention (S3)
			(S2a)	(S2b)	
Personal Norms	0.62	0.62	0.62	0.62	1
Fuel price stability					
Electric heating	0.33	0.33	0.33	0.33	0.33
Heat pump	0.49	0.49	0.49	0.49	0.49
Wood pellet heating	0.45	0.49	0.45/ 0.9 ¹	0.66	0.45
Indoor air quality					
Electric heating	0.52	0.52	0.52	0.52	0.52
Heat pump	0.67	0.67	0.67	0.67	0.67
Wood pellet heating	0.57	0.67	0.57/ 0.9 ²	0.57	0.57
Functional reliability					
Electric heating	0.85	0.85	0.85	0.85	0.85
Heat pump	0.72	0.72	0.72	0.72	0.72
Wood pellet heating	0.61	0.85	0.61/ 0.9 ³	0.85	0.61
Total cost					
Electric heating	0.48	0.48	0.48	0.48	0.48
Heat pump	0.43	0.43	0.43	0.43	0.43
Wood pellet heating	0.56	0.43	0.56/ 0.1 ⁴	0.56	0.56
Required work					
Electric heating	0.11	0.11	0.11	0.11	0.11
Heat pump	0.32	0.32	0.32	0.32	0.32
Wood pellet heating	0.57	0.11	0.57/ 0.1 ⁵	0.57	0.57

Note: See also Table 5-2 for parameter values for the base model. In scenario analysis, values in Table 5-5 is multiplied by its associated weight in Table 5.3 using equation (1)-(3)

¹ S2a – run 1: Fuel price stability of wood pellet heating is set to 0.9 and all other parameter values are the same as the base model

² S2a – run 2: Indoor air quality of wood pellet heating is set to 0.9 and all other parameter values are the same as the base model

³ S2a – run 3: Functional reliability of wood pellet heating is set to 0.9 and all other parameter values are the same as the base model

⁴ S2a – run 4: Total cost of wood pellet heating is set to 0.1 and all other parameter values are the same as the base model

⁵ S2a – run 5: Required work of wood pellet heating is set to 0.1 and all other parameter values are the same as the base model

5.6.1 Same Perceived Attributes as the Best Available Technology (BAT)

The base model indicates that wood pellet heating is perceived to be inferior in all of its attributes (see Table 5-5), so it is argued that this may explain the non-adoption of wood pellet heating. Therefore, the first scenario seeks to examine whether this is the case. At the same time, this scenario attempts to observe whether competitive advantage is necessary to win the market as argued by Rogers (2003) for the case of

wood pellet heating. Findings of Paper 3 support the importance of heating system attributes by indicating that wood pellet heating should be perceived advantageous before communication becomes effective for driving further diffusion. Therefore, the first scenario sets all the perceived attributes of wood pellet heating to be the same as those of the best available technology (BAT), given that all the other parameter values are the same as the base model (see Table 5-5, Same as BAT[S1]). If the first scenario fails to show further adoption of wood pellet heating, it can be implied that improving perceived wood pellet heating attributes to BAT may not be sufficient. Competitive advantage of wood pellet heating is hence necessary.

Simulation result suggests that the same subjective perception of attributes between wood pellet heating and the best available technology does not necessarily lead an uptake in wood pellet heating. Statistical analysis shows insignificant differences between base model and scenario 1 as shown in Figure 5-10 ($Chi^2 = 0.013$; $df = 79$; $p = 1$). The result, in other words, reflects that wood pellet heating should be superior to its competitors, consistent with diffusion of innovation theory in the sense that a technology must have a relative advantage in comparison to other competing technologies in order to be adopted (Rogers, 2003).

5.6.2 Individual vs. Simultaneous Development of Wood Pellet Heating

The second scenario aims to examine the hypothesis by Egger and Öhlinger (2002) that simultaneous development, such as stove technology together with the fuel market, is required to initialize the wood pellet market. The scenario is then divided into two parts. The first part addresses an individual development. Each perceived attribute of wood pellet heating is set to either 0.9 or 0.1, and a simulation run for each setting attribute is carried out (S2a). There are hence five simulation runs in total for individual development scenario (see note of Table 5-5). The second part concerns with simultaneous development of wood pellet heating. One example of simultaneous development is therefore presented in Table 5-5 (S2b).

Simulation results of the second scenario indicates that simultaneous development is required for wood pellet heating to diffuse, supporting the hypothesis of Egger and Öhlinger (2002). The simulation of individual improvement in each heating attribute results in non-adoption of wood pellet heating, except improvement in functional reliability. Even so, the perceived functional reliability of wood pellet heating must be extremely high, with a minimum requirement of 0.99 out of 1, which seems very difficult to achieve for real systems and is therefore considered unrealistic.

The second part of this scenario indicates that the improvement of perceived pellet price stability of 0.66 which is 1.46 times higher than previously, together with an improvement in functional reliability so that it is the same as that of electric heating, allows further diffusion of wood pellet heating. Additional simulation results indicate that once the perceived pellet price stability is very stable (0.9), the required

improvement of perceived functional reliability is 0.7. In contrast, if the perceived functional reliability is very high (0.9), perceived pellet price stability should be at least 0.59 to enable further adoption of wood pellet heating. Alternatively, both perceived functional reliability and pellet price stability should be at least 0.77 to make wood pellet diffusion possible. The simulation suggests that the interventions toward stable pellet price through, i.e., wood pellet price regulation, a more liquid market, or a government storage facility, together with technological development of the stoves increasing functional reliability, should be carried out simultaneously. This result corresponds eventually with the design principles for effective carbon emission reduction programs for household sector by Vandenberg et al. (2010), who suggest that program success is critically depending on the combination of financial incentives and other design principles such as simplicity, quality assurance, and marketing.

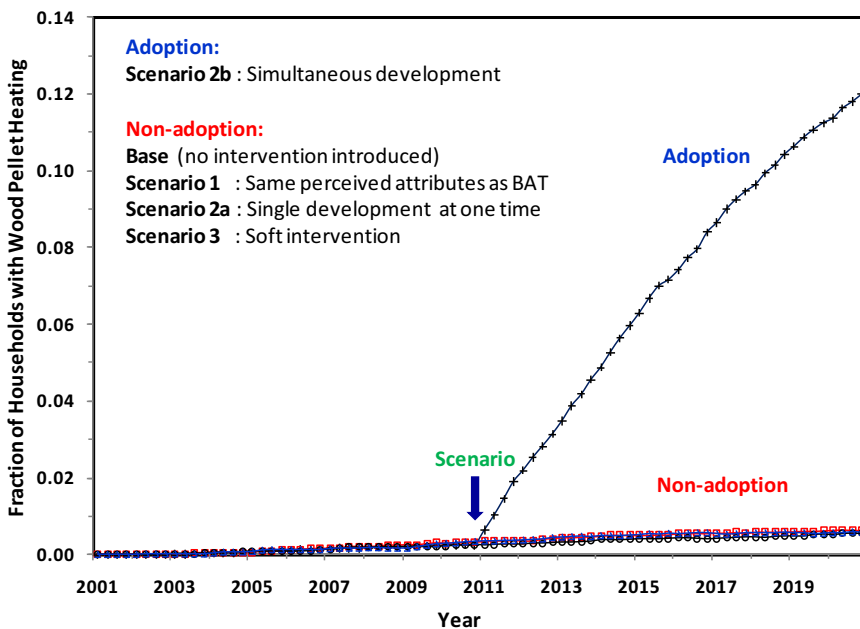

Figure 5-10 Scenario results for wood pellet heating (2001–2020)

5.6.3 Intervention Focusing on Norms/Values

The adoption of heat pump and wood pellet heating could be considered morally relevant since the decision could be derived from the inner values within a household, representing a personal obligation to use an environmentally friendly heating system. It is expected that influencing the household to adopt such a system through education, promotion, trustworthy models (e.g., celebrities with a good reputation), would lead to an increase in wood pellet heating uptake. Finding from Paper 2 (see section 4.2), however, suggested that an intervention focusing on norms or values should not be the

highest priority at present; rather, the improvement of perceived wood pellet attributes should be prioritized. This scenario attempts to look at the opportunity to implement interventions focusing on norms/values. The third scenario model thus assigns a value of 1 to the parameter of personal norms (pn), which reflects that all households in the simulation feel obliged to use an environmentally beneficial heating system (see Table 5-5 [S3]).

Simulation result displays a non-adoption of wood pellet heating (see Figure 5-10). Statistical analysis shows insignificant differences between base model and soft intervention focusing on norms/values ($Chi^2 = 0.017$; $df = 79$; $p = 1$). This result is consistent with finding of Paper 2. This means that wood pellet heating diffusion is not helped by households' high environmental consciousness in the present stage of market diffusion. Appealing to households' environmental conscience is therefore not a promising driver for wood pellet diffusion. One explanation could be the different perception by households as to which heating system is more environmentally friendly, as demonstrated by finding of Paper 1 indicating that non-adopters considers wood pellet heating to be the least environmentally friendly among the three heating systems, while they perceive heat pumps to be the most beneficial to the environment. If this seems to be the case, once the government decides to promote wood pellet heating, providing information on its environmental performance is thus necessary prior to the intervention. Moreover, households must be confident that they will receive benefits from adopting wood pellet heating. The improvement of perceived wood pellet attributes should also be prioritized prior to intervention focusing on norms or values.

Summarizing, scenario analysis suggests that the simultaneous development is a promising intervention for wood pellet heating to be further diffused. The improvements of wood pellet heating attributes are necessary and these improvements should be communicated to households, so that wood pellet heating is to be perceived advantageous.

Spatial results of the most frequent single run out of 30 simulation runs for the adoption and non-adoption of wood pellet heating are exhibited in Figure 5-11. In the case of adoption, it appears that the percentage (adopted wood pellet heating divided by total households residing in the area) for northern Norway (Nordland, Troms, Finnmark) is higher than that of western Norway (Rogaland, Hordaland, Sogn og Fjordane). This is in accordance with the empirical result of anticipated future heating system choice investigated in the Paper 3, thus confirming that households residing in the western part of Norway are more likely than those in the north to choose electric heating instead of a wood pellet stove. However, based on a number of simulation runs among districts in the northern part of Norway, households residing in Nordland and south of Troms adopted wood pellet heating, whereas those residing in Finnmark and north of Troms showed a non-adoption. This could be due to unavailability of bio-

energy resources in the north part of Norway. The spatial results indicate the significance of spatial/regional consideration in policy design.

Adoption

Non-adoption

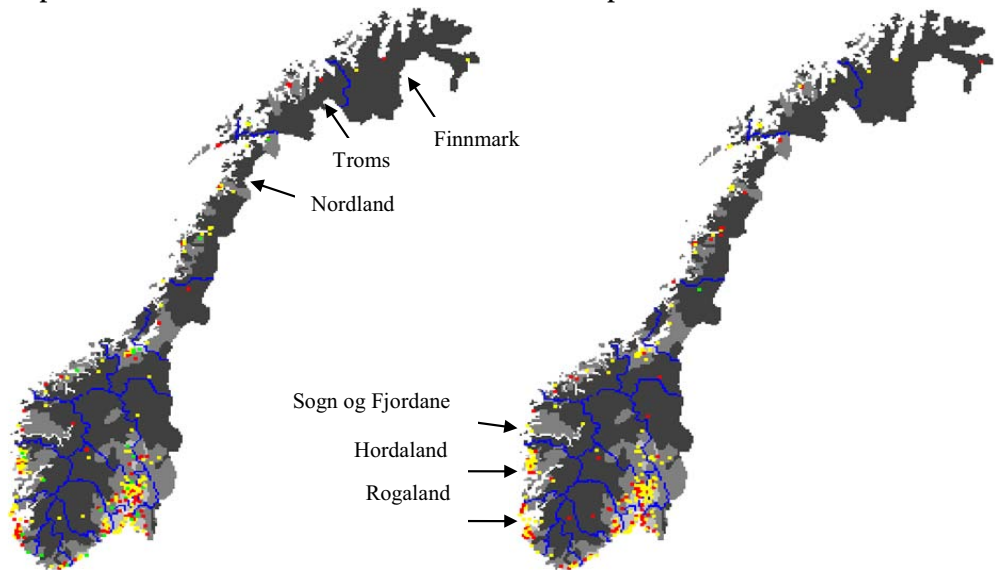

Figure 5-11. Spatial result at the end of simulation (red: electric heating, yellow: heat pump, green: wood pellet heating)

5.7 Limitations

Although this study presents interesting results, some limitations need to be highlighted so that future research can improve the model by addressing existing limitations. First, this model is appropriate for providing qualitative insights, but is not accurate for quantitative forecasting. This limitation is partly due to the trigger for decision making in the model being replacement time is assigned as a constant throughout scenario simulation. In reality, replacement time is not constant and is influenced by many factors such as fuel price, advertising and technological developments, to name a few. Therefore, a better understanding of the mechanism triggering heating system replacement is desirable. Second, the implementation of the total cost however may be challenging. Total cost corresponds to the entire cost of a heating system during its lifetime, constituting the investment, fuel and maintenance costs. Differentiating investment costs from operation costs enables the spotting of specific interventions, i.e., whether the intervention should focus on installation subsidies or on fuel tax (e.g., electricity tax). Third, the empirical survey used as input data for the simulation represented the condition at the time the survey is conducted, thus covering temporary perceptions. The importance of heating system attributes

(represented by regression weights) is assumed to be constant over the simulation time, which is not realistic. Since perceptions may change in response to events, a new survey must be conducted if the model is going to be used, e.g., within the next 10 years. Another interesting study would be to measure the values and regression weights in a time series (for example, annually) to reveal how and when they change. Fourth, the implementation of decision strategy should be improved by addressing the drivers underlying the strategy, which are need satisfaction and uncertainty, so that the decision strategy is endogenous process within the model. Last but not least, the model dealt with the perception on heating attributes, not the actual heating attributes. As there could be a gap between perceived and actual heating attributes, the simulation results should be interpreted with care because fixing problems by developing technological performance are tasks different from correcting misperceptions.

Summary and Suggestions for Future Work

6.1 Summary

High rate of adoption and diffusion of environmentally friendly heating systems is required in pursuit of sustainable development. The successful introduction of environmentally friendly technology certainly requires the understanding of consumer decision-making. This research work has in general contributed to a better understanding of heating system decision-making by Norwegian households (micro-level) which will then result in diffusion of various heating systems (macro-level). Agent-Based Modeling (ABM) combined with empirical research is examined as a methodological approach. The empirical survey is carried out in order to parameterize the simulation model, to obtain empirical facts, as well as, to validate the simulation result on micro-level (as independent data on micro-level is not available). Empirical analysis of the survey seeks to fully understand important features underlying decision-making and their implications in assisting simulation design. Simulation results demonstrate that the proposed methodology could be a promising technique to discover the decision mechanism by households underlying the diffusion of heating systems in Norway.

Below is the summary highlighting the major conceptual and empirical contributions of the thesis.

Conceptual contribution:

1. *Interdisciplinary approach:* Different perspectives, i.e. technology management, psychology, and complex system, are applied in this study to give comprehensive and richer insights of various aspects, including technical, economical, psychological, and social factors, in understanding decision-making.
2. *Inclusion of technological attributes (other than cost) and psychological factors in adoption-decisions:* The importance of investment costs and profitability to decision making have been emphasized in most of literatures within the context of energy investment, imputing that the decision about heating systems is primarily based on a narrow economic rationale. Given recent criticism of the *homo economicus* hypothesis, it is argued that this issue is an open research question. The fact the wood pellet heating in Norway has not been diffused further despite the investment subsidy indicates the needs of multiple

explanations. Paper 1 indicates operation cost is the third important, while investment cost is the least important attribute in decision-making where functional reliability is found to be the most important. Paper 4 resonates the insignificant effect of perceived total cost reduction of wood pellet heating alone on the diffusion of wood pellet heating. On the other hand, finding of Paper 1 exhibits high installation cost is the most perceived barrier for adoption of wood pellet heating which is supported by Paper 2 showing that the perceived total cost is the second significant influence, after functional reliability, in decision of wood pellet heating. The contradiction may indicate the existence of uncertainties, hidden costs, or ignorance because wood pellet heating is considered as a new emerging technology. For instance, households are more likely to undertake an investment if they are confident that a heating system is more reliable than others, thus indicating a necessity of multiple explanations. Hence, the study includes various heating system attributes, which are moderated by psychological factors, to provide a more complete picture than one focused narrowly on cost.

3. *Coupling agent-based modeling with empirical research:* Application of agent-based modeling to heating system application is also a novel contribution of this research. It is suggested that coupling agent-based modeling with empirical research could be a promising technique to address the research question. Given the fact that ABM applications are not generally successful, the proposed methodology demonstrates a resounding success of ABM application.

Empirical contribution:

Major empirical findings are summarized as follows,

1. *Role of information:* Information has indeed a crucial role in decision-making which can be reflected from finding of Paper 1 indicating different perception of which heating system is the most environmentally friendly despite the same level of environmental values, and lack of information is the top third barrier of wood pellet heating adoption. Findings of Paper 3 echo the importance of information by discovering low observability of wood pellet heating by a population sample. Furthermore, if one indicates a gap between actual and perceived heating system attributes, information is thus becoming even more important.
2. *Importance of functional reliability:* Findings from Paper 1 (functional reliability is the most important attributes in decision-making in both samples), Paper 2 (functional reliability is the significant attribute in the decision process of wood pellet heating) and Paper 3 (functional reliability is the significant attribute influencing the choice between wood pellet heating or heat pump), indicate that functional reliability is found to be the important technological attribute

influencing heating system choice. It thus deserves for more attention particularly when promoting a new technology.

3. *Adoption decision for wood pellet heating is a deliberative decision:* Although it is not surprising that adoption decision of wood pellet heating is a deliberative decision because of large amount of financial resource involved, this thesis provides empirical evidence of this issue. Moreover, Paper 2 demonstrates in more detail that the deliberation process is starting with the evaluation of heating system characteristics, mediated by attitudes and intentions.
4. *Potential interventions toward higher diffusion of wood pellet heating in Norway:* Relative advantages of wood pellet heating in comparison to its competitors and simultaneous development of wood pellet heating are necessary, whereas focusing norms/values is not a promising intervention for wood pellet heating, at least for now when a social reference group has not been formed.

6.2 Suggestions for Future Work

6.2.1 Empirical Analysis

Since this study only addresses three types of heating system, future work complementing this study may address other types of heating system especially those which are competitors and mostly adopted by Norwegian households, such as wood heating.

Wood pellet heating decision process studied in Paper 2 is modeled retrospectively which makes the validity of the results questionable to a certain extent. As the data is analyzed on a co-relational basis, causal relations cannot be proven, but can be suggested. Thus, a study following people through the process of deciding for a heating system and measuring the variables several times throughout the process would be extremely insightful. Moreover, the inclusion of beautiful design and comfort of wood pellet heating could improve the model.

Based on the findings of Paper 3, factors leading to satisfaction/dissatisfaction of using wood pellet heating could be explored because results from such analysis will be useful to reveal factors affecting low preference toward wood pellet heating.

6.2.2 Simulation Study

Simple model with capability of representing the real system is preferred to a more complex one. Modelers attempt to keep their models as simple as possible but no simpler. Given that the proposed model is reasonably good to reproduce historical data, the suggestion to develop the model is however not intended to make the model more complicated. Rather, the priority should be given to be able to test the model against new data and to gain insights from further simulations. One area deserving to be explored, for example, is the investigation of the minimum adopters of wood pellet heating required to achieve a critical mass, a point when enough individuals have

adopted a technology so that the continued adoption of the technology is self-sustaining. Findings of Paper 3 have observed that number of households using wood pellet heating is currently below the critical number. It would therefore be interesting to explore the critical mass of wood pellet heating adopters and what kinds of strategies helping wood pellet heating to reach this stage.

In addition, in order to test the applicability, the model could also be applied in cases which involve end-user decision-making and a technology which has a relatively long lifetime (years), such as electric versus conventional cars, water-saving technologies (e.g., shower-head, toilet), insulation, home refurbishment, etc.

Furthermore, as the developed model focuses on end-user decision-making, the model could hence be expanded to include interactions among other agents, such as suppliers and/or government if one wants to investigate market dynamic.

References

- Ajzen, I. (1991). The theory of planned behavior. *Organizational Behavior and Human Decision Process*, 50, 179-211.
- Bamberg, S., Ajzen, I., Schmidt, P. (2003). Choice travel mode in the Theory of Planned Behavior: The roles of past behavior, habit and reasoned action. *Basic and Applied Social Psychology*, 25, 175-187.
- Bjørnstad, E., Grande, J., Sand, R., Wendelborg, C. (2005). Evaluering av tilskuddordninger til varmepumper, pelletskaminer og styringssystemer, Nord Trøndelags-forskning. Retrieved September 2009; http://generator.firmanett.no/t/foforsk/doc/Ra_2_05.pdf, in Norwegian
- Black, J. S., Stern, P. C., Elworth, J. T. (1985). Personal and contextual influences on household energy adaptations. *Journal of Applied Psychology*, 70(1), 3-21.
- Bonabeau, E., (2002). Agent-based modeling: Methods and techniques for simulating human susyem, *Proceedings of the National Academy of Sciences of The United States of America*, 99 (3), 7280-7287.
- Boulanger, P., Brechet, T. (2005). Models for policy making in sustainable development: The state of the art and perspective for research, *Ecological Economics*, 55, 337-350.
- Brottemsmo, J. (1994). *Residential heating choice and energy demand: Norwegian responses in 1980 and 1990*, Working Paper No. 118/1993, Center of Research in Economics and Business Administration.
- Buzing, P., Eiben, A., Schut, M. (2005) Emerging communication and cooperation in evolving agent societies. *Journal of Artificial Societies and Social Simulation*, 8(1)2. <http://jasss.soc.surrey.ac.uk/8/1/2.html>.
- Donnelly, J.P. (2007). The Research Methods Knowledge Base, 3e, William Trochim, Cornell University, SUNY-Buffalo. <http://writing.colostate.edu/guides/research/survey/com2d1.cfm>.
- Dunlap, R. E., Van Liere, K. D. (1978). The "New Environmental Paradigm": A proposed measuring instrument and preliminary results. *The Journal of Environmental Education*, 9 (4), 10-19
- Eclipse (2009). Retrieved in August 2009; <http://www.eclipse.org/>
- Egger, C., Öhlinger, C. (2002). Strategy and methods to create a new market. Paper presented at the Pellets 2002: The World Conference on Pellets, Stockholm, Sweden 2-4 September 2002
- Ek, K., Söderholm, P. (2008). Norms and economic motivation in the Swedish green electricity market. *Ecological economics*, 68, 169-182.

- Enova (2003). *Varmestudien 2003. Grunnlag for utbygging og bruk av varmeenergi i det norske energisystemet*. Enova, Trondheim
- Epstein, J.M., Axtell, R. (1996). *Growing Artificial Societies – Social Science from the Bottom Up*. MIT Press, Cambridge, MA.
- Erdős, P., Rényi, A. (1959). On Random Graphs. I. *Publicationes Mathematicae*, 6, 290–297.
- Fagiolo, G., Windrum, P., Moneta, A. (2006). *Empirical validation of agent-based models: A critical survey*, Laboratory of Economics and Management, Pisa. Retrieved in April 2009; <http://www.lem.sssup.it/WPLem/files/2006-14.pdf>.
- Fishburn, P.C. (1970). *Utility Theory for Decision Making*. Publications in Operations Research, No. 18. New York: John Wiley and Sons.
- Flentge, F., Polani, D., Uthmann, T. (2001) Modelling the emergence of possession norms using memes. *Journal of Artificial Societies and Social Simulation*, 4(4)3. <http://jasss.soc.surrey.ac.uk/4/4/3.html>.
- Forrester, J. W., Senge, P. M. (1980). Tests for building confidence in system dynamics models. *TIME Studies in the Management Science*, 14, 209-228.
- Frambach, R. T. (1993). An integrated model of organizational adoption and diffusion of innovations. *European Journal of Marketing*, 27(5), 22-41.
- Garcia, R. (2005). Uses of agent-based modeling in innovation/new product development Research. *Journal Production and Innovation Management*, 22, 380-398.
- Geroski, P.A. (2000). Models of technology diffusion. *Research Policy*, 29, 603-625.
- Gilbert, N., Troitzsch, K. G. (1999). *Simulation for the Social Scientist*, Open University Press, Buckingham, UK.
- Gilbert, N. (2008). *Agent-Based Models: Quantitative applications in the social sciences*. Sage University Paper Series, Los Angeles.
- Grübler, A. (1998). *Technology and global change*. Cambridge University Press. In cooperation with IIASA. The International Institute for Systems Analysis, Vienna, Austria
- Gumerman, G.J., Swedlund, A.C., Dean, J.S., Epstein, J.M. (2002): *The Evolution of Social Behaviour in the Prehistoric American Southwest*. SFI Working Paper 02-12-067, SantaFe (NM).
- IEA (2005). *Energy Policies of IEA Countries – Norway – 2005 Review*. Retrieved in June 2010; http://www.iea.org/publications/free_new_Desc.asp?PUBS_ID=1580
- Innstilling til Stortinget fra energi- og miljøkomiteen nr. 133 (2002-2003). Retrieved in September 2009; <http://www.stortinget.no/Global/pdf/Innstillinger/Stortinget/2002-2003/inns-200203-133.pdf>
- Jager, W. (2000). *Modeling consumer behavior*. Doctoral thesis, Rijksuniversiteit Groningen, the Netherlands

- Janssen, M. A., Jager, W. (2002). Stimulating diffusion of green products: Co-evolution between firms and consumers. *Journal of Evolutionary Economics*, 12, 283-306
- Janssen, M. A. (2007). *Agent Based Modelling*. Internet Encyclopedia of Ecological Economics.; http://www.ecoeco.org/pdf/agent_based%20_modeling.pdf.
- Jeyaraj, A., Rottman, J., Lacity, M. (2006). A review of predictors, linkages and biases in IT innovation adoption research. *Journal of Information Technology*, 21, 1-23.
- Johns, K. D., Khovanova, K. M., Welch, E. W. (2009). Fleet conversion in local government: Determinants of driver fuel choice of bi-fuel vehicles. *Environment and Behavior*, 41 (3), 402-426.
- Kasanen, P., Lakshmanan, T. R. (1989). Residential Heating Choices of Finnish Household, *Economic Geography*, 65(2), 1
- Labay, D. G., Kinnear, T. C. (1981). Exploring the consumer decision process in the adoption of solar energy systems. *Journal of Consumer Research*, 8, 271-278
- Lalonde, R., Jackson, E. L. (2002). The new environmental paradigm scale: Has it outlived its usefulness? *The Journal of Environmental Education*, 33(4), 28-36.
- Lohr, S. L. (2009). *Sampling: Design and Analysis*, 2nd Edition. Brooks/Cole: Boston, MA.
- Mahapatra, K., Gustavsson, L. (2008). An adopter-centric approach to analyze the diffusion patterns of innovative residential heating systems in Sweden. *Energy Policy*, 36(2), 577-590.
- Midgley, D. F., Morrison, P. D., Roberts, J. H. (1992). The effect of network structure in industrial diffusion processes. *Research Policy*, 21(6), 533-552.
- Moore, G. A. (1999). *Crossing the Chasm*, Revised edition, Harper Business Essentials, US.
- Moore, G., Benbasat, I. (1991). Development of an instrument to measure the perceptions of adopting an information technology innovation. *Information Systems Research*, 2(3), 192-222
- Nashoug, H., Pedersen, F.D. (2004). *Opportunities and barriers for development of a Norwegian wood pellet market*. Thesis, Institutt for Økonomi og Samfunnsfag, NLH; 2004. (in Norwegian).
- Negro, S., Hekkert, M., Alkemade, F. (2010). Seven typical system failures that hamper the diffusion of sustainable energy technologies. Paper to be presented at the Summer Conference 2010 on Opening up innovation: Strategy, organization and technology, Imperial College London Business School, June 16-18, 2010.
- Nesbakken, R. (1998). *Residential energy consumption for space heating in Norwegian households: A Discrete-continuous choice approach*. Discussion Papers No. 231, Research Department, Statistics Norway.
- Nesbakken, R., Strøm, S. (1994). *The choice of space heating system and energy consumption in Norwegian household*, Statistics Norway.
- Norsk Varmepumpeforening (2006), <http://www.novap.no/>

References

- Painuly, J.P. (2002). Barriers to renewable energy penetration; a framework for analysis. *Renewable Energy*, 24(2), 73-89
- Qudrat-Ullah, H. (2005). Structural validation of system dynamics and agent-based simulation models, *Proceedings 19th European Conference on Modelling and Simulation*, ISBN 1-84233-112-4.
- Randers, J., Arnstad, E., Lekva, H., Flåten, O., Nord, L., Hedstein, A., Aam, S. (2006). *Et Klimavennlig Norge*, Norges offentlige utredninger 2006: 18. Retrieved in December 2010;
<http://www.regjeringen.no/Rpub/NOU/20062006/018/PDFS/NOU200620060018000/DDDPDFS.pdf>
- REMODECE Project (2006); <http://www.sintef.no/Home/Petroleum-and-Energy/SINTEF-Energy-Research/Xergi/Xergi-2008/New-knowledge-about-power-consumption-distribution/>
- Repast (2009). Retrieved in August 2009; <http://repast.sourceforge.net/>
- Reusswig, F., Lotze-Campen, H., Gerlinger, K. (2008). Changing global lifestyle and consumption patterns: the case of energy and food, Potsdam Institute for Climate Impact Research. Retrieved in June 2008;
http://www.populationenvironmentresearch.org/papers/Lotze-Campen_Reusswig_Paper.pdf.
- Rogers, E. M. (2003). *Diffusion of Innovations*, 5th ed., New York: Free Press.
- Schelling, T.C. (1969). Models of Segregation. *American Economic Review, Papers and Proceedings*, 59 (2), 488-493.
- Schelling, T.C. (1978): *Micromotives and Macrobehaviour*. Norton.
- Schwarz, N., Ernst, A. (2009). Agent-based modeling of the diffusion of environmental innovations – An empirical approach. *Technological Forecasting & Social Change*, 76, 497-511
- Schwoon, M. (2006). Simulating the Adoption of Fuel Cell Vehicles. *Journal of Evolutionary Economics*, 16 (4), 435-472
- Scodari, P. F., Hardie, I. W. (1985). Heating costs and household wood stove acquisition: A Discrete choice demand mode. *Northeastern Journal of Agricultural and Resource Economics*, 14(1). Retrieved in October 2007; <http://purl.umn.edu/28935>
- Solli, C., Reenaas, M., Strømman, A.H., Hertwich, E.G. (2009). Life cycle assessment of wood-based heating in Norway. *International Journal of Life Cycle Assessment*, 14, (6), 517-528.
- Statistics Norway (2006). Retrieved in January 2008;
<http://www.ssb.no/emner/01/03/10/husenergi/>
- Statistics Norway (2009). Retrieved in December 2009;
<http://www.ssb.no/emner/05/01/inntgeo/tab-2009-05-13-01.html>
- Statistics Norway (2010); <http://www.ssb.no/energi/>

-
- Steg, L., Dreijerink, L., Abrahamse, W. (2005). Factors influencing the acceptability of energy policies: A test of VBN theory. *Journal of Environmental Psychology*, 25, 415-425.
- Tonglet, M., Phillips, P. S., Read, A.D. (2004). Using the Theory of Planned behavior to investigate the determinants of recycling behavior: a case study from Brixworth, UK, *Resource, Conservation and Recycling*, 41, 191-214.
- Trømborg, E., Bolkesjø, T.F., Solberg, B. (2008). Biomass market and trade in Norway: Status and future prospects. *Biomass and Bioenergy*, 32, 660-671.
- Valente T.W., Schuster D.V. (2002). The public health perspective for communicating environmental issues. In T. Dietz & P. Stern (Eds.) *The Human Dimensions of Global Change*. Washington DC : National Academy Press. pp. 105–24.
- Vandenbergh, M. P., Stern, P. C., Gardner, G. T., Dietz, T., Gilligan, J. M. (2010). Implementing the behavioral wedge: Designing and adopting effective carbon emissions reduction programs. *Environmental Law Reporter*, 40, 10545-10552.
- Vogel, S. (1994). *Environmental attitudes and behavior in the agricultural sector empirically determined by use of an attitude model*. Diskussionspapier Nr. 32-W-94. Retrieved in June 2008; http://www.boku.ac.at/wpr/papers/d_papers/dp_cont.html.
- Watts, D. J., Strogatz, S. H. (1998). Collective dynamics of small-world networks. *Nature*, 393, 409-10.
- Weisstein, E. W. (2010a). Moore Neighborhood. From MathWorld--A Wolfram Web Resource; <http://mathworld.wolfram.com/MooreNeighborhood.html>
- Weisstein, E. W. (2010b). Von Neumann Neighborhood. From MathWorld--A Wolfram Web Resource; <http://mathworld.wolfram.com/vonNeumannNeighborhood.html>

Questionnaires

A.1. Population Sample (Non-Adopter)

A.2. Wood Pellet Sample (Adopter)

A.1. Population Sample (Non-Adopter)

Norske husholdningers oppvarmingssystem

Dette spørreskjemaet har til hensikt å undersøke norske husholdningers beslutninger om oppvarmingskilder i sine boliger. Resultatene vil bli brukt til å analysere muligheter for alternative oppvarmingssystemer i Norge i en tid der det er stor politisk fokus på å få mer miljøvennlige oppvarmingssystem.

Det er viktig å få husholdningenes meninger om oppvarmingssystemet; hva ligger til grunn for de valg som er tatt? Ditt svar vil gi oss kunnskap om dette!

Ingen boliger er like. Dette gjør at alternativene i denne undersøkelsen ikke alltid passer. Vi ber dem allikevel svare så godt de kan i forhold til alternativene som er gitt.

Du/dere er en av 1500 husholdninger som er valgt ut til denne undersøkelsen. Naturligvis er deltagelsen i denne undersøkelsen frivillig. Imidlertid er vi takknemlig for din deltakelse! Ditt svar vil kun være gyldig viss mange nok deltar i undersøkelsen. Som en oppmuntring vil vi trekke ut tre tilfeldige vinnere som får utbetalt en **gevinst på 1000 kroner**, det løse arket må da fylles ut med navn og adresse. Vi håper at du tar deg tid til å gi uttrykk for ditt syn og formidler dine erfaringer om ditt eget oppvarmingssystem. Vi ber deg om å returnere det utfylte spørreskjemaet **senest 27 september 2008**. Bruk den ferdigfrankerte konvolutten til retur.

Ditt svar vil bli behandlet konfidensielt. Informasjonen vil bare bli brukt til vitenskapelige formål og vil ikke deles med tredje part (feks. energiselskaper eller myndigheter). Din adresse vil ikke koples til ditt svar ved at skjemaet vil anonymiseres umiddelbart etter datainnsamlingen er ferdig.

Undersøkelsen har et løst ark vedlagt. Dette kan fylles ut om en ønsker å delta i trekningen av gevinster og også ønsker å få tilsendt resultatene av undersøkelsen på e-post.

Har du spørsmål, tanker/ idéer eller kommentarer til spørreskjemaet er du velkommen til å kontakte oss på:

Geir Skjevraak

Tel. 912 46 525

Epost: gss@ntnu.no

Institutt for energi- og prosesssteknikk

Norges Teknisk-Naturvitenskapelige

Universitet (NTNU)

7491 Trondheim

Bertha Maya Sopha

Epost: bertha.sopha@ntnu.no

Fax: 73 59 89 43

Program for industriell økologi

Norges Teknisk-Naturvitenskapelige

Universitet (NTNU)

7491 Trondheim



DEL – A

De følgende spørsmålene angår deg og din bolig. Set ett kryss (X) for det (de) alternativ(ene) som stemmer best på deg.

1.	Hva er ditt kjønn?	<input type="checkbox"/> mann <input type="checkbox"/> kvinne					
2.	Hvilket år ble du født?	<table border="1"><tr><td>1</td><td>9</td><td></td><td></td></tr></table>	1	9			
1	9						
3.	Hva er årlig total husholdningsinntekt (etter skatt)?	<input type="checkbox"/> under NOK 150,000 <input type="checkbox"/> NOK 150,001- NOK 250,000 <input type="checkbox"/> NOK 250,001- NOK 350,000 <input type="checkbox"/> NOK 350,001- NOK 450,000 <input type="checkbox"/> NOK 450,001- NOK 550,000 <input type="checkbox"/> mer enn NOK 550,000					
4.	Hva er ditt utdanningsnivå?	<input type="checkbox"/> Grunnskole <input type="checkbox"/> Videregående skole <input type="checkbox"/> Universitets- og høyskole					
5.	Hva er postnummer for din bolig?	<table border="1"><tr><td></td><td></td><td></td><td></td><td></td></tr></table>					
6.	Eier du din egen bolig?	<input type="checkbox"/> ja <input type="checkbox"/> nei					
7.	Hvor mange kvadratmeter oppvarmet areal har din bolig? m ²					

DEL – B

De følgende spørsmålene vurderer hva som ligger til grunn for ditt valg av oppvarmingssystem. Sett ett kryss (X) for det alternativet som stemmer best.

1.	Hvor mange personer har anbefalt ulike typer oppvarmingssystem for deg?	<input type="checkbox"/> 0 <input type="checkbox"/> 1-5 <input type="checkbox"/> 6-10 <input type="checkbox"/> 11-15 <input type="checkbox"/> 16-20 <input type="checkbox"/> mer enn 20																		
2.	Hvor viktige er/var disse anbefalingene i ditt valg av oppvarmingssystem?	<table><tr><td>ikke viktig</td><td></td><td></td><td></td><td></td><td>veldig viktig</td></tr><tr><td></td><td>1</td><td>2</td><td>3</td><td>4</td><td>5</td></tr><tr><td></td><td><input type="checkbox"/></td><td><input type="checkbox"/></td><td><input type="checkbox"/></td><td><input type="checkbox"/></td><td><input type="checkbox"/></td></tr></table>	ikke viktig					veldig viktig		1	2	3	4	5		<input type="checkbox"/>	<input type="checkbox"/>	<input type="checkbox"/>	<input type="checkbox"/>	<input type="checkbox"/>
ikke viktig					veldig viktig															
	1	2	3	4	5															
	<input type="checkbox"/>	<input type="checkbox"/>	<input type="checkbox"/>	<input type="checkbox"/>	<input type="checkbox"/>															

3.	Hvor mange personer har du anbefalt en viss type oppvarmingssystem?	<input type="checkbox"/> 0 <input type="checkbox"/> 1-5 <input type="checkbox"/> 6-10 <input type="checkbox"/> 11-15 <input type="checkbox"/> 16-20 <input type="checkbox"/> mer enn 20
4.	Hvilket oppvarmingssystem vil du anbefale til andre?	<input type="checkbox"/> elektrisk oppvarming <input type="checkbox"/> varmpumpe <input type="checkbox"/> pelletsovn <input type="checkbox"/> ikke noen av de tre over

DEL – C

De følgende spørsmålene analyserer når og hvordan du treffer en beslutning om oppvarmingssystem. Sett et kryss (X) for det(de) alternativet(ene) som stemmer best på deg.

1.	Hvem bestemte/bestemmer hvilket oppvarmingssystem som er/skal installeres i din bolig?	<input type="checkbox"/> jeg <input type="checkbox"/> min partner <input type="checkbox"/> begge <input type="checkbox"/> andre:																																															
2.	Hvilke oppvarmingssystem har du en eller annen gang installert/bestilt? (sett kryss ved alle relevante alternativer)	<input type="checkbox"/> elektrisk oppvarming <input type="checkbox"/> vedovn <input type="checkbox"/> peis <input type="checkbox"/> varmpumpe <input type="checkbox"/> pelletsovn <input type="checkbox"/> andre: <input type="checkbox"/> har ikke skiftet/fornytt oppvarmingssystem																																															
3.	Hvor fornøyd var du med dine tidligere oppvarmingssystemer?	<table style="width: 100%; border-collapse: collapse;"> <thead> <tr> <th style="width: 5%;"></th> <th colspan="2" style="text-align: center;">veldig misfornøyd</th> <th colspan="2" style="text-align: center;">veldig fornøyd</th> </tr> <tr> <th></th> <th style="text-align: center;">1</th> <th style="text-align: center;">2</th> <th style="text-align: center;">3</th> <th style="text-align: center;">4</th> <th style="text-align: center;">5</th> </tr> </thead> <tbody> <tr> <td>a. elektrisk oppvarming</td> <td style="text-align: center;"><input type="checkbox"/></td> <td style="text-align: center;"><input type="checkbox"/></td> <td style="text-align: center;"><input type="checkbox"/></td> <td style="text-align: center;"><input type="checkbox"/></td> <td style="text-align: center;"><input type="checkbox"/></td> </tr> <tr> <td>b. vedovn</td> <td style="text-align: center;"><input type="checkbox"/></td> <td style="text-align: center;"><input type="checkbox"/></td> <td style="text-align: center;"><input type="checkbox"/></td> <td style="text-align: center;"><input type="checkbox"/></td> <td style="text-align: center;"><input type="checkbox"/></td> </tr> <tr> <td>c. peis</td> <td style="text-align: center;"><input type="checkbox"/></td> <td style="text-align: center;"><input type="checkbox"/></td> <td style="text-align: center;"><input type="checkbox"/></td> <td style="text-align: center;"><input type="checkbox"/></td> <td style="text-align: center;"><input type="checkbox"/></td> </tr> <tr> <td>d. varmpumpe</td> <td style="text-align: center;"><input type="checkbox"/></td> <td style="text-align: center;"><input type="checkbox"/></td> <td style="text-align: center;"><input type="checkbox"/></td> <td style="text-align: center;"><input type="checkbox"/></td> <td style="text-align: center;"><input type="checkbox"/></td> </tr> <tr> <td>e. pelletsovn</td> <td style="text-align: center;"><input type="checkbox"/></td> <td style="text-align: center;"><input type="checkbox"/></td> <td style="text-align: center;"><input type="checkbox"/></td> <td style="text-align: center;"><input type="checkbox"/></td> <td style="text-align: center;"><input type="checkbox"/></td> </tr> <tr> <td>f. andre:</td> <td style="text-align: center;"><input type="checkbox"/></td> <td style="text-align: center;"><input type="checkbox"/></td> <td style="text-align: center;"><input type="checkbox"/></td> <td style="text-align: center;"><input type="checkbox"/></td> <td style="text-align: center;"><input type="checkbox"/></td> </tr> </tbody> </table>		veldig misfornøyd		veldig fornøyd			1	2	3	4	5	a. elektrisk oppvarming	<input type="checkbox"/>	<input type="checkbox"/>	<input type="checkbox"/>	<input type="checkbox"/>	<input type="checkbox"/>	b. vedovn	<input type="checkbox"/>	<input type="checkbox"/>	<input type="checkbox"/>	<input type="checkbox"/>	<input type="checkbox"/>	c. peis	<input type="checkbox"/>	<input type="checkbox"/>	<input type="checkbox"/>	<input type="checkbox"/>	<input type="checkbox"/>	d. varmpumpe	<input type="checkbox"/>	<input type="checkbox"/>	<input type="checkbox"/>	<input type="checkbox"/>	<input type="checkbox"/>	e. pelletsovn	<input type="checkbox"/>	<input type="checkbox"/>	<input type="checkbox"/>	<input type="checkbox"/>	<input type="checkbox"/>	f. andre:	<input type="checkbox"/>	<input type="checkbox"/>	<input type="checkbox"/>	<input type="checkbox"/>	<input type="checkbox"/>
	veldig misfornøyd		veldig fornøyd																																														
	1	2	3	4	5																																												
a. elektrisk oppvarming	<input type="checkbox"/>	<input type="checkbox"/>	<input type="checkbox"/>	<input type="checkbox"/>	<input type="checkbox"/>																																												
b. vedovn	<input type="checkbox"/>	<input type="checkbox"/>	<input type="checkbox"/>	<input type="checkbox"/>	<input type="checkbox"/>																																												
c. peis	<input type="checkbox"/>	<input type="checkbox"/>	<input type="checkbox"/>	<input type="checkbox"/>	<input type="checkbox"/>																																												
d. varmpumpe	<input type="checkbox"/>	<input type="checkbox"/>	<input type="checkbox"/>	<input type="checkbox"/>	<input type="checkbox"/>																																												
e. pelletsovn	<input type="checkbox"/>	<input type="checkbox"/>	<input type="checkbox"/>	<input type="checkbox"/>	<input type="checkbox"/>																																												
f. andre:	<input type="checkbox"/>	<input type="checkbox"/>	<input type="checkbox"/>	<input type="checkbox"/>	<input type="checkbox"/>																																												
4.	Hvilke(t) oppvarmingssystem benytter du nå? (sett kryss ved	<input type="checkbox"/> elektrisk oppvarming <input type="checkbox"/> vedovn																																															

<p><u>samtlig</u>e alternativ som er relevante for deg)?</p>	<input type="checkbox"/> peis <input type="checkbox"/> varmepumpe <input type="checkbox"/> pelletsovn <input type="checkbox"/> andre:																																																
<p>5. Hvilket oppvarmingsystem bruker du det meste av tida? (sett bare <u>ett</u> kryss for hovedoppvarmingsystemet)</p>	<input type="checkbox"/> elektrisk oppvarming <input type="checkbox"/> vedovn <input type="checkbox"/> peis <input type="checkbox"/> varmepumpe <input type="checkbox"/> pelletsovn <input type="checkbox"/> andre:																																																
<p>6. Hvor fornøyd er du med ditt(dine) eksisterende oppvarmings-system(er)?</p> <p>a. elektrisk oppvarming</p> <p>b. vedovn</p> <p>c. peis</p> <p>d. varmepumpe</p> <p>e. pelletsovn</p> <p>f. andre:</p>	<table border="1"> <thead> <tr> <th></th> <th colspan="2">veldig misfornøyd</th> <th colspan="2"></th> <th>veldig fornøyd</th> </tr> <tr> <th></th> <th>1</th> <th>2</th> <th>3</th> <th>4</th> <th>5</th> </tr> </thead> <tbody> <tr> <td>a. elektrisk oppvarming</td> <td><input type="checkbox"/></td> <td><input type="checkbox"/></td> <td><input type="checkbox"/></td> <td><input type="checkbox"/></td> <td><input type="checkbox"/></td> </tr> <tr> <td>b. vedovn</td> <td><input type="checkbox"/></td> <td><input type="checkbox"/></td> <td><input type="checkbox"/></td> <td><input type="checkbox"/></td> <td><input type="checkbox"/></td> </tr> <tr> <td>c. peis</td> <td><input type="checkbox"/></td> <td><input type="checkbox"/></td> <td><input type="checkbox"/></td> <td><input type="checkbox"/></td> <td><input type="checkbox"/></td> </tr> <tr> <td>d. varmepumpe</td> <td><input type="checkbox"/></td> <td><input type="checkbox"/></td> <td><input type="checkbox"/></td> <td><input type="checkbox"/></td> <td><input type="checkbox"/></td> </tr> <tr> <td>e. pelletsovn</td> <td><input type="checkbox"/></td> <td><input type="checkbox"/></td> <td><input type="checkbox"/></td> <td><input type="checkbox"/></td> <td><input type="checkbox"/></td> </tr> <tr> <td>f. andre:</td> <td><input type="checkbox"/></td> <td><input type="checkbox"/></td> <td><input type="checkbox"/></td> <td><input type="checkbox"/></td> <td><input type="checkbox"/></td> </tr> </tbody> </table>		veldig misfornøyd				veldig fornøyd		1	2	3	4	5	a. elektrisk oppvarming	<input type="checkbox"/>	<input type="checkbox"/>	<input type="checkbox"/>	<input type="checkbox"/>	<input type="checkbox"/>	b. vedovn	<input type="checkbox"/>	<input type="checkbox"/>	<input type="checkbox"/>	<input type="checkbox"/>	<input type="checkbox"/>	c. peis	<input type="checkbox"/>	<input type="checkbox"/>	<input type="checkbox"/>	<input type="checkbox"/>	<input type="checkbox"/>	d. varmepumpe	<input type="checkbox"/>	<input type="checkbox"/>	<input type="checkbox"/>	<input type="checkbox"/>	<input type="checkbox"/>	e. pelletsovn	<input type="checkbox"/>	<input type="checkbox"/>	<input type="checkbox"/>	<input type="checkbox"/>	<input type="checkbox"/>	f. andre:	<input type="checkbox"/>	<input type="checkbox"/>	<input type="checkbox"/>	<input type="checkbox"/>	<input type="checkbox"/>
	veldig misfornøyd				veldig fornøyd																																												
	1	2	3	4	5																																												
a. elektrisk oppvarming	<input type="checkbox"/>	<input type="checkbox"/>	<input type="checkbox"/>	<input type="checkbox"/>	<input type="checkbox"/>																																												
b. vedovn	<input type="checkbox"/>	<input type="checkbox"/>	<input type="checkbox"/>	<input type="checkbox"/>	<input type="checkbox"/>																																												
c. peis	<input type="checkbox"/>	<input type="checkbox"/>	<input type="checkbox"/>	<input type="checkbox"/>	<input type="checkbox"/>																																												
d. varmepumpe	<input type="checkbox"/>	<input type="checkbox"/>	<input type="checkbox"/>	<input type="checkbox"/>	<input type="checkbox"/>																																												
e. pelletsovn	<input type="checkbox"/>	<input type="checkbox"/>	<input type="checkbox"/>	<input type="checkbox"/>	<input type="checkbox"/>																																												
f. andre:	<input type="checkbox"/>	<input type="checkbox"/>	<input type="checkbox"/>	<input type="checkbox"/>	<input type="checkbox"/>																																												
<p>7. Om du ikke er fornøyd med din(e) eksisterende oppvarmingsystem(er), ønsker du da å installere et nytt?</p>	<input type="checkbox"/> ja <input type="checkbox"/> nei, oppgi grunnen/årsak																																																
<p>8. Hva var / ville være en grunn for å endre ditt oppvarmingsystem (sett kryss ved alle relevante alternativer)?</p>	<input type="checkbox"/> eksisterende oppvarmingsystem er ødelagt <input type="checkbox"/> eksisterende oppvarmingsystem er for gammelt <input type="checkbox"/> høye brenselkostnader <input type="checkbox"/> høye vedlikeholdskostnader <input type="checkbox"/> flytting til en ny bolig <input type="checkbox"/> oppussing bolig <input type="checkbox"/> andre:																																																
<p>9. Hvilket oppvarmingsystem vil du velge hvis du bestemmer deg for å bytte ut ditt gamle oppvarmingsystem (sett kryss ved bare <u>ett</u> alternativ)?</p>	<input type="checkbox"/> elektrisk oppvarming <input type="checkbox"/> vedovn <input type="checkbox"/> peis <input type="checkbox"/> varmepumpe <input type="checkbox"/> pelletsovn, gå til spørsmål 12 <input type="checkbox"/> andre:																																																
<p>10. Hvilke av disse er / ville være de tre viktigste faktorene som</p>	<input type="checkbox"/> høye installeringskostnader <input type="checkbox"/> høye driftskostnader																																																

<p>hindrer deg fra å velge pelletsovn (sett kryss bare ved <u>tre</u> alternativer)?</p>	<input type="checkbox"/> mye arbeid <input type="checkbox"/> upålitelig <input type="checkbox"/> usikker tilgang til brensel <input type="checkbox"/> lav innendørs luftkvalitet <input type="checkbox"/> mangel på informasjon <input type="checkbox"/> ingen anbefaler den til meg <input type="checkbox"/> lav markedsandel <input type="checkbox"/> mangel på teknologi <input type="checkbox"/> vanskeligheter med å etablere pelletslager og håndtering av pellets <input type="checkbox"/> mangel på tilgang til service og støtte for oppvarmingssystemet <input type="checkbox"/> andre:																																										
<p>11. Ville du vurdere å installere pelletsovn hvis den var subsidiert (ca. NOK 4 000) ?</p>	<input type="checkbox"/> ja <input type="checkbox"/> nei <input type="checkbox"/> vet ikke																																										
<p>12. Leter du aktivt etter informasjon om alternative oppvarmings-system?</p>	<input type="checkbox"/> ja <input type="checkbox"/> nei, gå til spørsmål 14																																										
<p>13. Hvor viktig er de følgende informasjonskildene for deg når du leter etter informasjon om oppvarmingssystem? Velg informasjons kilden(ene) som er relevant(e) til deg.</p> <p>a. avis/blad</p> <p>b. internet</p> <p>c. venner/familie</p> <p>d. leverandør</p> <p>e. flygebrev/informasjonsavis</p> <p>f. andre:</p>	<table border="0"> <tr> <td></td> <td style="text-align: center;">ikke viktig</td> <td></td> <td></td> <td></td> <td style="text-align: center;">veldig viktig</td> </tr> <tr> <td></td> <td style="text-align: center;">1</td> <td style="text-align: center;">2</td> <td style="text-align: center;">3</td> <td style="text-align: center;">4</td> <td style="text-align: center;">5</td> </tr> <tr> <td></td> <td style="text-align: center;"><input type="checkbox"/></td> <td style="text-align: center;"><input type="checkbox"/></td> <td style="text-align: center;"><input type="checkbox"/></td> <td style="text-align: center;"><input type="checkbox"/></td> <td style="text-align: center;"><input type="checkbox"/></td> </tr> <tr> <td></td> <td style="text-align: center;"><input type="checkbox"/></td> <td style="text-align: center;"><input type="checkbox"/></td> <td style="text-align: center;"><input type="checkbox"/></td> <td style="text-align: center;"><input type="checkbox"/></td> <td style="text-align: center;"><input type="checkbox"/></td> </tr> <tr> <td></td> <td style="text-align: center;"><input type="checkbox"/></td> <td style="text-align: center;"><input type="checkbox"/></td> <td style="text-align: center;"><input type="checkbox"/></td> <td style="text-align: center;"><input type="checkbox"/></td> <td style="text-align: center;"><input type="checkbox"/></td> </tr> <tr> <td></td> <td style="text-align: center;"><input type="checkbox"/></td> <td style="text-align: center;"><input type="checkbox"/></td> <td style="text-align: center;"><input type="checkbox"/></td> <td style="text-align: center;"><input type="checkbox"/></td> <td style="text-align: center;"><input type="checkbox"/></td> </tr> <tr> <td></td> <td style="text-align: center;"><input type="checkbox"/></td> <td style="text-align: center;"><input type="checkbox"/></td> <td style="text-align: center;"><input type="checkbox"/></td> <td style="text-align: center;"><input type="checkbox"/></td> <td style="text-align: center;"><input type="checkbox"/></td> </tr> </table>		ikke viktig				veldig viktig		1	2	3	4	5		<input type="checkbox"/>	<input type="checkbox"/>	<input type="checkbox"/>	<input type="checkbox"/>	<input type="checkbox"/>		<input type="checkbox"/>	<input type="checkbox"/>	<input type="checkbox"/>	<input type="checkbox"/>	<input type="checkbox"/>		<input type="checkbox"/>	<input type="checkbox"/>	<input type="checkbox"/>	<input type="checkbox"/>	<input type="checkbox"/>		<input type="checkbox"/>	<input type="checkbox"/>	<input type="checkbox"/>	<input type="checkbox"/>	<input type="checkbox"/>		<input type="checkbox"/>	<input type="checkbox"/>	<input type="checkbox"/>	<input type="checkbox"/>	<input type="checkbox"/>
	ikke viktig				veldig viktig																																						
	1	2	3	4	5																																						
	<input type="checkbox"/>	<input type="checkbox"/>	<input type="checkbox"/>	<input type="checkbox"/>	<input type="checkbox"/>																																						
	<input type="checkbox"/>	<input type="checkbox"/>	<input type="checkbox"/>	<input type="checkbox"/>	<input type="checkbox"/>																																						
	<input type="checkbox"/>	<input type="checkbox"/>	<input type="checkbox"/>	<input type="checkbox"/>	<input type="checkbox"/>																																						
	<input type="checkbox"/>	<input type="checkbox"/>	<input type="checkbox"/>	<input type="checkbox"/>	<input type="checkbox"/>																																						
	<input type="checkbox"/>	<input type="checkbox"/>	<input type="checkbox"/>	<input type="checkbox"/>	<input type="checkbox"/>																																						
<p>14. Hvordan avgjør/avgjorde du ditt valg av oppvarmingssystem (velg alternativet som passer din strategi best)?</p>	<input type="checkbox"/> kjøper det samme oppvarmingssystem som før <input type="checkbox"/> vurderer alle oppvarmingssystemer for å oppnå maksimal nytteverdi <input type="checkbox"/> velger oppvarmingssystem som har den største andel blant mine naboer/venner																																										

<input type="checkbox"/> sammenligner det oppvarmingssystem som er anvendt mest blant mine naboer og mitt foregående oppvarmingssystem, og velger det beste						
15. Hvor betydningsfullt er et oppvarmingssystems egenskaper basert på din erfaring?	ikke viktig					veldig viktig
		1	2	3	4	5
	a. funksjonsstabilitet	<input type="checkbox"/>	<input type="checkbox"/>	<input type="checkbox"/>	<input type="checkbox"/>	<input type="checkbox"/>
	b. innendørs luftkvalitet	<input type="checkbox"/>	<input type="checkbox"/>	<input type="checkbox"/>	<input type="checkbox"/>	<input type="checkbox"/>
	c. investeringskostnader	<input type="checkbox"/>	<input type="checkbox"/>	<input type="checkbox"/>	<input type="checkbox"/>	<input type="checkbox"/>
	d. driftskostnader	<input type="checkbox"/>	<input type="checkbox"/>	<input type="checkbox"/>	<input type="checkbox"/>	<input type="checkbox"/>
	e. drift- og vedlikeholdsarbeid	<input type="checkbox"/>	<input type="checkbox"/>	<input type="checkbox"/>	<input type="checkbox"/>	<input type="checkbox"/>
f. sikker tilgang på brensel	<input type="checkbox"/>	<input type="checkbox"/>	<input type="checkbox"/>	<input type="checkbox"/>	<input type="checkbox"/>	
16. I hvor stor grad påvirkes ditt valg av oppvarmingssystem av andre mennesker? Anslå innvirkningen fra andre mennesker på din beslutning. Vanligvis finnes noe påvirkning fra andre mennesker. 0% betyr at din beslutning er helt uavhengig av andre menneskers påvirkning, 100% betyr at du tar din bestemmelse bare på grunnlag av andres meninger.	<input type="checkbox"/> 0 %					
	<input type="checkbox"/> 20 %					
	<input type="checkbox"/> 40 %					
	<input type="checkbox"/> 60 %					
	<input type="checkbox"/> 80 %					
	<input type="checkbox"/> 100 %					

DEL – D

De følgende spørsmålene analyserer de psykologiske faktorene som påvirker beslutningsprosessen. Det er i dette tilfellet valgt bare 3 alternative oppvarmingssystem som avkryssingsalternativ. Sett ett kryss (X) for det alternativet som stemmer best for deg.

1. Hvor mange ganger har du tatt en avgjørelse vedrørende oppvarmingssystem? ganger
2. Hvor mange ganger har du valgt oppvarmingssystemet under? ganger

	a. elektrisk oppvarming	ganger
	b. varmepumpe	ganger
	c. pelletsovn		
3.	Hvor miljøvennlig synes du de følgende oppvarmingssystemene er?	ikke miljøvennlig	helt miljøvennlig
		1	2
		3	4
		5	
	a. elektrisk oppvarming	<input type="checkbox"/>	<input type="checkbox"/>
	b. varmepumpe	<input type="checkbox"/>	<input type="checkbox"/>
	c. pelletsovn	<input type="checkbox"/>	<input type="checkbox"/>
4.	På grunn av mine verdier / prinsipper, føler jeg en personlig forpliktelse til å bruke et miljøvennlig oppvarmingssystem	helt uenig	helt enig
		1	2
		3	4
		5	6
		7	
		<input type="checkbox"/>	<input type="checkbox"/>
		<input type="checkbox"/>	<input type="checkbox"/>
		<input type="checkbox"/>	<input type="checkbox"/>
5.	Når jeg installerer nytt oppvarmingssystem er det min hensikt å bruke denne typen	helt uenig	helt enig
		1	2
		3	4
		5	6
		7	
	a. elektrisk oppvarming	<input type="checkbox"/>	<input type="checkbox"/>
	b. varmepumpe	<input type="checkbox"/>	<input type="checkbox"/>
	c. pelletsovn	<input type="checkbox"/>	<input type="checkbox"/>
6.	Det ville være bra å benytte denne typen oppvarmingssystem	helt uenig	helt enig
		1	2
		3	4
		5	6
		7	
	a. elektrisk oppvarming	<input type="checkbox"/>	<input type="checkbox"/>
	b. varmepumpe	<input type="checkbox"/>	<input type="checkbox"/>
	c. pelletsovn	<input type="checkbox"/>	<input type="checkbox"/>
7.	Hvis jeg ønsket kunne jeg lett bruke denne typen oppvarmingssystem	helt uenig	helt enig
		1	2
		3	4
		5	6
		7	
	a. elektrisk oppvarming	<input type="checkbox"/>	<input type="checkbox"/>
	b. varmepumpe	<input type="checkbox"/>	<input type="checkbox"/>
	c. pelletsovn	<input type="checkbox"/>	<input type="checkbox"/>
8.	Jeg tror at denne typen oppvarmingssystem har høyere driftssikkerhet	helt uenig	helt enig
		1	2
		3	4
		5	6
		7	
	a. elektrisk oppvarming	<input type="checkbox"/>	<input type="checkbox"/>
	b. varmepumpe	<input type="checkbox"/>	<input type="checkbox"/>
	c. pelletsovn	<input type="checkbox"/>	<input type="checkbox"/>

9.	Dårlig inneluftkvalitet er forårsaket av denne typen oppvarmingssystem	helt uenig	1	2	3	4	5	6	7	helt enig
	a. elektrisk oppvarming		<input type="checkbox"/>	<input type="checkbox"/>	<input type="checkbox"/>	<input type="checkbox"/>	<input type="checkbox"/>	<input type="checkbox"/>	<input type="checkbox"/>	
	b. varmepumpe		<input type="checkbox"/>	<input type="checkbox"/>	<input type="checkbox"/>	<input type="checkbox"/>	<input type="checkbox"/>	<input type="checkbox"/>	<input type="checkbox"/>	
	c. pelletsovn		<input type="checkbox"/>	<input type="checkbox"/>	<input type="checkbox"/>	<input type="checkbox"/>	<input type="checkbox"/>	<input type="checkbox"/>	<input type="checkbox"/>	
10.	Denne typen oppvarmingssystem er for kostbart	helt uenig	1	2	3	4	5	6	7	helt enig
	a. elektrisk oppvarming		<input type="checkbox"/>	<input type="checkbox"/>	<input type="checkbox"/>	<input type="checkbox"/>	<input type="checkbox"/>	<input type="checkbox"/>	<input type="checkbox"/>	
	b. varmepumpe		<input type="checkbox"/>	<input type="checkbox"/>	<input type="checkbox"/>	<input type="checkbox"/>	<input type="checkbox"/>	<input type="checkbox"/>	<input type="checkbox"/>	
	c. pelletsovn		<input type="checkbox"/>	<input type="checkbox"/>	<input type="checkbox"/>	<input type="checkbox"/>	<input type="checkbox"/>	<input type="checkbox"/>	<input type="checkbox"/>	
11.	Jeg ville være nødt til å gjøre en masse drifts- og vedlikeholdsarbeider hvis jeg bruker denne typen av oppvarmingssystem	helt uenig	1	2	3	4	5	6	7	helt enig
	a. elektrisk oppvarming		<input type="checkbox"/>	<input type="checkbox"/>	<input type="checkbox"/>	<input type="checkbox"/>	<input type="checkbox"/>	<input type="checkbox"/>	<input type="checkbox"/>	
	b. varmepumpe		<input type="checkbox"/>	<input type="checkbox"/>	<input type="checkbox"/>	<input type="checkbox"/>	<input type="checkbox"/>	<input type="checkbox"/>	<input type="checkbox"/>	
	c. pelletsovn		<input type="checkbox"/>	<input type="checkbox"/>	<input type="checkbox"/>	<input type="checkbox"/>	<input type="checkbox"/>	<input type="checkbox"/>	<input type="checkbox"/>	
12.	Denne type oppvarmingssystem har stabile priser på brensel/energi.	helt uenig	1	2	3	4	5	6	7	helt enig
	a. elektrisk oppvarming		<input type="checkbox"/>	<input type="checkbox"/>	<input type="checkbox"/>	<input type="checkbox"/>	<input type="checkbox"/>	<input type="checkbox"/>	<input type="checkbox"/>	
	b. varmepumpe		<input type="checkbox"/>	<input type="checkbox"/>	<input type="checkbox"/>	<input type="checkbox"/>	<input type="checkbox"/>	<input type="checkbox"/>	<input type="checkbox"/>	
	c. pelletsovn		<input type="checkbox"/>	<input type="checkbox"/>	<input type="checkbox"/>	<input type="checkbox"/>	<input type="checkbox"/>	<input type="checkbox"/>	<input type="checkbox"/>	
13.	Miljøaspektet ved bestemmelse av oppvarmingssystem er solid forankret i mitt verdigrunnlag	helt uenig	1	2	3	4	5	6	7	helt enig
			<input type="checkbox"/>	<input type="checkbox"/>	<input type="checkbox"/>	<input type="checkbox"/>	<input type="checkbox"/>	<input type="checkbox"/>	<input type="checkbox"/>	
14.	Jeg har til hensikt å bruk denne typen av oppvarmingssystem i fremtiden	helt uenig	1	2	3	4	5	6	7	helt enig
	a. elektrisk oppvarming		<input type="checkbox"/>	<input type="checkbox"/>	<input type="checkbox"/>	<input type="checkbox"/>	<input type="checkbox"/>	<input type="checkbox"/>	<input type="checkbox"/>	
	b. varmepumpe		<input type="checkbox"/>	<input type="checkbox"/>	<input type="checkbox"/>	<input type="checkbox"/>	<input type="checkbox"/>	<input type="checkbox"/>	<input type="checkbox"/>	
	c. pelletsovn		<input type="checkbox"/>	<input type="checkbox"/>	<input type="checkbox"/>	<input type="checkbox"/>	<input type="checkbox"/>	<input type="checkbox"/>	<input type="checkbox"/>	
15.	Det ville være verdifullt for meg å bruke denne typen av oppvarmingssystem	helt uenig	1	2	3	4	5	6	7	helt enig

	a. elektrisk oppvarming	<input type="checkbox"/>	<input type="checkbox"/>	<input type="checkbox"/>	<input type="checkbox"/>	<input type="checkbox"/>	<input type="checkbox"/>	<input type="checkbox"/>
	b. varmepumpe	<input type="checkbox"/>	<input type="checkbox"/>	<input type="checkbox"/>	<input type="checkbox"/>	<input type="checkbox"/>	<input type="checkbox"/>	<input type="checkbox"/>
	c. pelletsovn	<input type="checkbox"/>	<input type="checkbox"/>	<input type="checkbox"/>	<input type="checkbox"/>	<input type="checkbox"/>	<input type="checkbox"/>	<input type="checkbox"/>
16.	Det ville være lett å dekke mitt oppvarmingsbehov med denne typen av oppvarmingssystem	helt uenig						helt enig
		1	2	3	4	5	6	7
	a. elektrisk oppvarming	<input type="checkbox"/>	<input type="checkbox"/>	<input type="checkbox"/>	<input type="checkbox"/>	<input type="checkbox"/>	<input type="checkbox"/>	<input type="checkbox"/>
	b. varmepumpe	<input type="checkbox"/>	<input type="checkbox"/>	<input type="checkbox"/>	<input type="checkbox"/>	<input type="checkbox"/>	<input type="checkbox"/>	<input type="checkbox"/>
	c. pelletsovn	<input type="checkbox"/>	<input type="checkbox"/>	<input type="checkbox"/>	<input type="checkbox"/>	<input type="checkbox"/>	<input type="checkbox"/>	<input type="checkbox"/>
17.	Denne typen av oppvarmingssystem er pålitelig	helt uenig						helt enig
		1	2	3	4	5	6	7
	a. elektrisk oppvarming	<input type="checkbox"/>	<input type="checkbox"/>	<input type="checkbox"/>	<input type="checkbox"/>	<input type="checkbox"/>	<input type="checkbox"/>	<input type="checkbox"/>
	b. varmepumpe	<input type="checkbox"/>	<input type="checkbox"/>	<input type="checkbox"/>	<input type="checkbox"/>	<input type="checkbox"/>	<input type="checkbox"/>	<input type="checkbox"/>
	c. pelletsovn	<input type="checkbox"/>	<input type="checkbox"/>	<input type="checkbox"/>	<input type="checkbox"/>	<input type="checkbox"/>	<input type="checkbox"/>	<input type="checkbox"/>
18.	Denne typen av oppvarmingssystem resulterer i ren og ikke altfor tørr inneluft	helt uenig						helt enig
		1	2	3	4	5	6	7
	a. elektrisk oppvarming	<input type="checkbox"/>	<input type="checkbox"/>	<input type="checkbox"/>	<input type="checkbox"/>	<input type="checkbox"/>	<input type="checkbox"/>	<input type="checkbox"/>
	b. varmepumpe	<input type="checkbox"/>	<input type="checkbox"/>	<input type="checkbox"/>	<input type="checkbox"/>	<input type="checkbox"/>	<input type="checkbox"/>	<input type="checkbox"/>
	c. pelletsovn	<input type="checkbox"/>	<input type="checkbox"/>	<input type="checkbox"/>	<input type="checkbox"/>	<input type="checkbox"/>	<input type="checkbox"/>	<input type="checkbox"/>
19.	Jeg tror at denne typen av oppvarmingssystem ville koste mer enn jeg har råd til	helt uenig						helt enig
		1	2	3	4	5	6	7
	a. elektrisk oppvarming	<input type="checkbox"/>	<input type="checkbox"/>	<input type="checkbox"/>	<input type="checkbox"/>	<input type="checkbox"/>	<input type="checkbox"/>	<input type="checkbox"/>
	b. varmepumpe	<input type="checkbox"/>	<input type="checkbox"/>	<input type="checkbox"/>	<input type="checkbox"/>	<input type="checkbox"/>	<input type="checkbox"/>	<input type="checkbox"/>
	c. pelletsovn	<input type="checkbox"/>	<input type="checkbox"/>	<input type="checkbox"/>	<input type="checkbox"/>	<input type="checkbox"/>	<input type="checkbox"/>	<input type="checkbox"/>
20.	Det er mye arbeid knyttet til denne typen av oppvarmingssystem	helt uenig						helt enig
		1	2	3	4	5	6	7
	a. elektrisk oppvarming	<input type="checkbox"/>	<input type="checkbox"/>	<input type="checkbox"/>	<input type="checkbox"/>	<input type="checkbox"/>	<input type="checkbox"/>	<input type="checkbox"/>
	b. varmepumpe	<input type="checkbox"/>	<input type="checkbox"/>	<input type="checkbox"/>	<input type="checkbox"/>	<input type="checkbox"/>	<input type="checkbox"/>	<input type="checkbox"/>
	c. pelletsovn	<input type="checkbox"/>	<input type="checkbox"/>	<input type="checkbox"/>	<input type="checkbox"/>	<input type="checkbox"/>	<input type="checkbox"/>	<input type="checkbox"/>
21.	Prisnivået er stabilt for denne typen av oppvarmingssystem	helt uenig						helt enig

	1	2	3	4	5	6	7
a. elektrisk oppvarming	<input type="checkbox"/>	<input type="checkbox"/>	<input type="checkbox"/>	<input type="checkbox"/>	<input type="checkbox"/>	<input type="checkbox"/>	<input type="checkbox"/>
b. varmepumpe	<input type="checkbox"/>	<input type="checkbox"/>	<input type="checkbox"/>	<input type="checkbox"/>	<input type="checkbox"/>	<input type="checkbox"/>	<input type="checkbox"/>
c. pelletsovn	<input type="checkbox"/>	<input type="checkbox"/>	<input type="checkbox"/>	<input type="checkbox"/>	<input type="checkbox"/>	<input type="checkbox"/>	<input type="checkbox"/>

DEL – E

De følgende spørsmålene vurderer din personlige mening vedrørende miljø og samfunn. Det er ikke rette eller gale svar. Sett ett kryss (X) på en skala mellom 1 og 5 i samsvar med din mening.

		helt uenig				helt enig
		1	2	3	4	5
1.	Menneskeheten må leve i pakt med naturen for å overleve på sikt	<input type="checkbox"/>	<input type="checkbox"/>	<input type="checkbox"/>	<input type="checkbox"/>	<input type="checkbox"/>
2.	Menneskeheten overforbruker naturressursene	<input type="checkbox"/>	<input type="checkbox"/>	<input type="checkbox"/>	<input type="checkbox"/>	<input type="checkbox"/>
3.	Jorden er som et romskip med begrensede ressurser og plass	<input type="checkbox"/>	<input type="checkbox"/>	<input type="checkbox"/>	<input type="checkbox"/>	<input type="checkbox"/>
4.	Det finnes en grense for vekst som vårt industrialiserte samfunn ikke må overskride	<input type="checkbox"/>	<input type="checkbox"/>	<input type="checkbox"/>	<input type="checkbox"/>	<input type="checkbox"/>
5.	Menneskeheten er skapt for å kontrollere resten av naturen	<input type="checkbox"/>	<input type="checkbox"/>	<input type="checkbox"/>	<input type="checkbox"/>	<input type="checkbox"/>
6.	Planter og dyr eksisterer hovedsakelig for å bli forbrukt av mennesker	<input type="checkbox"/>	<input type="checkbox"/>	<input type="checkbox"/>	<input type="checkbox"/>	<input type="checkbox"/>

		helt uenig				helt enig
	<u>Hvordan burde vårt samfunn se ut?</u>	1	2	3	4	5
1.	Et samfunn som gir høyere prioritet til miljømessige hensyn enn til økonomisk utvikling	<input type="checkbox"/>	<input type="checkbox"/>	<input type="checkbox"/>	<input type="checkbox"/>	<input type="checkbox"/>
2.	Et samfunn som prøver å danne	<input type="checkbox"/>	<input type="checkbox"/>	<input type="checkbox"/>	<input type="checkbox"/>	<input type="checkbox"/>

	velstand men ikke på bekostning av miljømessig risiko					
3.	Et samfunn som legger vekt på arbeidsgleden som det mest positive av menneskelig velvære	<input type="checkbox"/>	<input type="checkbox"/>	<input type="checkbox"/>	<input type="checkbox"/>	<input type="checkbox"/>
4.	Et samfunn der en person dømmes hovedsaklig på basis av ens menneskelige egenskaper	<input type="checkbox"/>	<input type="checkbox"/>	<input type="checkbox"/>	<input type="checkbox"/>	<input type="checkbox"/>
5.	Et samfunn som har mange muligheter for en innbygger til å delta i de politiske prosesser	<input type="checkbox"/>	<input type="checkbox"/>	<input type="checkbox"/>	<input type="checkbox"/>	<input type="checkbox"/>
6.	Et samfunn som anstrenger seg for å beholde naturen som den er	<input type="checkbox"/>	<input type="checkbox"/>	<input type="checkbox"/>	<input type="checkbox"/>	<input type="checkbox"/>

Du er velkommen å skrive kommentarer ut over det som er gitt i spørreskjemaet i følgende rubrikk:

Tusen takk at du besvarte dette spørreskjemaet !

A.2. Wood Pellet Sample (Adopter)

Norske husholdningers oppvarmingssystem

Dette spørreskjemaet har til hensikt å undersøke norske husholdningers beslutninger om oppvarmingskilder i sine boliger. Resultatene vil bli brukt til å analysere muligheter for alternative oppvarmingssystemer i Norge i en tid der det er stor politisk fokus på å få mer miljøvennlige oppvarmingssystemer.

Det er viktig å få husholdningenes meninger om oppvarmingssystemet; hva ligger til grunn for de valg som er tatt? Ditt svar vil gi oss kunnskap om dette!

Ingen boliger er like. Dette gjør at alternativene i denne undersøkelsen ikke alltid passer. Vi ber dem allikevel svare så godt de kan i forhold til alternativene som er gitt.

Du/dere er en av 1500 husholdninger som er valgt ut til denne undersøkelsen. Naturligvis er deltagelsen i denne undersøkelsen frivillig. Imidlertid er vi takknemlig for din deltakelse! Ditt svar vil kun være gyldig viss mange nok deltar i undersøkelsen. Som en oppmuntring vil vi trekke ut en tilfeldig vinner som vil få **et års forbruk av trepellets som gevinst**, det løse arket må da fylles ut med navn og adresse. Vi håper at du tar deg tid til å gi uttrykk for ditt syn og formidler dine erfaringer om ditt eget oppvarmingssystem. Vi ber deg om å returnere det utfylte spørreskjemaet **senest 27 september 2008**. Bruk den ferdigfrankerte konvolutten til retur.

Ditt svar vil bli behandlet konfidensielt. Informasjonen vil bare bli brukt til vitenskapelige formål og vil ikke deles med tredje part (feks. energiselskaper eller myndigheter). Din adresse vil ikke koples til ditt svar ved at skjemaet vil anonymiseres umiddelbart etter datainnsamlingen er ferdig.

Undersøkelsen har et løst ark vedlagt. Dette kan fylles ut om en ønsker å delta i trekningen av gevinst og også ønsker å få tilsendt resultatene av undersøkelsen på e-post.

Har du spørsmål, tanker/ idéer eller kommentarer til spørreskjemaet er du velkommen til å kontakte oss på:

Geir Skjevraak

Tel. 912 46 525

Epost: gss@ntnu.no

Institutt for energi- og prosesssteknikk

Norges Teknisk-Naturvitenskapelige

Universitet (NTNU)

7491 Trondheim

Bertha Maya Sopha

Epost: bertha.sopha@ntnu.no

Fax: 73 59 89 43

Program for industriell økologi

Norges Teknisk-Naturvitenskapelige

Universitet (NTNU)

7491 Trondheim



DEL – A

De følgende spørsmålene angår deg og din bolig. Set ett kryss (X) for det (de) alternativ(ene) som stemmer best på deg.

1.	Hva er ditt kjønn?	<input type="checkbox"/> mann <input type="checkbox"/> kvinne				
2.	Hvilket år ble du født?	<table border="1"><tr><td>1</td><td>9</td><td></td><td></td></tr></table>	1	9		
1	9					
3.	Hva er årlig total husholdningsinntekt (etter skatt)?	<input type="checkbox"/> under NOK 150,000 <input type="checkbox"/> NOK 150,001- NOK 250,000 <input type="checkbox"/> NOK 250,001- NOK 350,000 <input type="checkbox"/> NOK 350,001- NOK 450,000 <input type="checkbox"/> NOK 450,001- NOK 550,000 <input type="checkbox"/> mer enn NOK 550,000				
4.	Hva er ditt utdanningsnivå?	<input type="checkbox"/> Grunnskole <input type="checkbox"/> Videregående skole <input type="checkbox"/> Universitets- og høyskole				
5.	Hva er postnummer for din bolig?	<table border="1"><tr><td></td><td></td><td></td><td></td></tr></table>				
6.	Eier du din egen bolig?	<input type="checkbox"/> ja <input type="checkbox"/> nei				
7.	Hvor mange kvadratmeter oppvarmet areal har din bolig? m ²				

DEL – B

De følgende spørsmålene vurderer hva som ligger til grunn for ditt valg av oppvarmingssystem. Sett ett kryss (X) for det alternativet som stemmer best.

1.	Hvor mange personer har anbefalt ulike typer oppvarmingssystem for deg?	<input type="checkbox"/> 0 <input type="checkbox"/> 1-5 <input type="checkbox"/> 6-10 <input type="checkbox"/> 11-15 <input type="checkbox"/> 16-20 <input type="checkbox"/> mer enn 20																		
2.	Hvor viktige er/var disse anbefalingene i ditt valg av oppvarmingssystem?	<table><tr><td>ikke viktig</td><td></td><td></td><td></td><td></td><td>veldig viktig</td></tr><tr><td></td><td>1</td><td>2</td><td>3</td><td>4</td><td>5</td></tr><tr><td></td><td><input type="checkbox"/></td><td><input type="checkbox"/></td><td><input type="checkbox"/></td><td><input type="checkbox"/></td><td><input type="checkbox"/></td></tr></table>	ikke viktig					veldig viktig		1	2	3	4	5		<input type="checkbox"/>	<input type="checkbox"/>	<input type="checkbox"/>	<input type="checkbox"/>	<input type="checkbox"/>
ikke viktig					veldig viktig															
	1	2	3	4	5															
	<input type="checkbox"/>	<input type="checkbox"/>	<input type="checkbox"/>	<input type="checkbox"/>	<input type="checkbox"/>															

3. Hvor mange personer har du anbefalt en viss type oppvarmingssystem?	<input type="checkbox"/> 0 <input type="checkbox"/> 1-5 <input type="checkbox"/> 6-10 <input type="checkbox"/> 11-15 <input type="checkbox"/> 16-20 <input type="checkbox"/> mer enn 20
4. Hvilket oppvarmingssystem vil du anbefale til andre?	<input type="checkbox"/> elektrisk oppvarming <input type="checkbox"/> varmepumpe <input type="checkbox"/> pelletsovn <input type="checkbox"/> ikke noen av de tre over

DEL – C

De følgende spørsmålene analyserer når og hvordan du treffer en beslutning om oppvarmingssystem. Sett et kryss (X) for det(de) alternativet(ene) som stemmer best på deg.

1. Hvem bestemte/bestemmer hvilket oppvarmingssystem som er/skal installeres i din bolig?	<input type="checkbox"/> jeg <input type="checkbox"/> min partner <input type="checkbox"/> begge <input type="checkbox"/> andre:																																																
2. Hvilke oppvarmingssystem har du en eller annen gang installert/bestilt? (sett kryss ved alle relevante alternativer)	<input type="checkbox"/> elektrisk oppvarming <input type="checkbox"/> vedovn <input type="checkbox"/> peis <input type="checkbox"/> varmepumpe <input type="checkbox"/> pelletsovn <input type="checkbox"/> andre: <input type="checkbox"/> har ikke skiftet/fornytt oppvarmingssystem																																																
3. Hvor fornøyd var du med dine tidligere oppvarmingssystemer?	<table style="width: 100%; border-collapse: collapse;"> <thead> <tr> <th></th> <th colspan="2" style="text-align: center;">veldig misfornøyd</th> <th colspan="3" style="text-align: center;">veldig fornøyd</th> </tr> <tr> <th></th> <th style="text-align: center;">1</th> <th style="text-align: center;">2</th> <th style="text-align: center;">3</th> <th style="text-align: center;">4</th> <th style="text-align: center;">5</th> </tr> </thead> <tbody> <tr> <td>a. elektrisk oppvarming</td> <td style="text-align: center;"><input type="checkbox"/></td> <td style="text-align: center;"><input type="checkbox"/></td> <td style="text-align: center;"><input type="checkbox"/></td> <td style="text-align: center;"><input type="checkbox"/></td> <td style="text-align: center;"><input type="checkbox"/></td> </tr> <tr> <td>b. vedovn</td> <td style="text-align: center;"><input type="checkbox"/></td> <td style="text-align: center;"><input type="checkbox"/></td> <td style="text-align: center;"><input type="checkbox"/></td> <td style="text-align: center;"><input type="checkbox"/></td> <td style="text-align: center;"><input type="checkbox"/></td> </tr> <tr> <td>c. peis</td> <td style="text-align: center;"><input type="checkbox"/></td> <td style="text-align: center;"><input type="checkbox"/></td> <td style="text-align: center;"><input type="checkbox"/></td> <td style="text-align: center;"><input type="checkbox"/></td> <td style="text-align: center;"><input type="checkbox"/></td> </tr> <tr> <td>d. varmepumpe</td> <td style="text-align: center;"><input type="checkbox"/></td> <td style="text-align: center;"><input type="checkbox"/></td> <td style="text-align: center;"><input type="checkbox"/></td> <td style="text-align: center;"><input type="checkbox"/></td> <td style="text-align: center;"><input type="checkbox"/></td> </tr> <tr> <td>e. pelletsovn</td> <td style="text-align: center;"><input type="checkbox"/></td> <td style="text-align: center;"><input type="checkbox"/></td> <td style="text-align: center;"><input type="checkbox"/></td> <td style="text-align: center;"><input type="checkbox"/></td> <td style="text-align: center;"><input type="checkbox"/></td> </tr> <tr> <td>f. andre:</td> <td style="text-align: center;"><input type="checkbox"/></td> <td style="text-align: center;"><input type="checkbox"/></td> <td style="text-align: center;"><input type="checkbox"/></td> <td style="text-align: center;"><input type="checkbox"/></td> <td style="text-align: center;"><input type="checkbox"/></td> </tr> </tbody> </table>		veldig misfornøyd		veldig fornøyd				1	2	3	4	5	a. elektrisk oppvarming	<input type="checkbox"/>	<input type="checkbox"/>	<input type="checkbox"/>	<input type="checkbox"/>	<input type="checkbox"/>	b. vedovn	<input type="checkbox"/>	<input type="checkbox"/>	<input type="checkbox"/>	<input type="checkbox"/>	<input type="checkbox"/>	c. peis	<input type="checkbox"/>	<input type="checkbox"/>	<input type="checkbox"/>	<input type="checkbox"/>	<input type="checkbox"/>	d. varmepumpe	<input type="checkbox"/>	<input type="checkbox"/>	<input type="checkbox"/>	<input type="checkbox"/>	<input type="checkbox"/>	e. pelletsovn	<input type="checkbox"/>	<input type="checkbox"/>	<input type="checkbox"/>	<input type="checkbox"/>	<input type="checkbox"/>	f. andre:	<input type="checkbox"/>	<input type="checkbox"/>	<input type="checkbox"/>	<input type="checkbox"/>	<input type="checkbox"/>
	veldig misfornøyd		veldig fornøyd																																														
	1	2	3	4	5																																												
a. elektrisk oppvarming	<input type="checkbox"/>	<input type="checkbox"/>	<input type="checkbox"/>	<input type="checkbox"/>	<input type="checkbox"/>																																												
b. vedovn	<input type="checkbox"/>	<input type="checkbox"/>	<input type="checkbox"/>	<input type="checkbox"/>	<input type="checkbox"/>																																												
c. peis	<input type="checkbox"/>	<input type="checkbox"/>	<input type="checkbox"/>	<input type="checkbox"/>	<input type="checkbox"/>																																												
d. varmepumpe	<input type="checkbox"/>	<input type="checkbox"/>	<input type="checkbox"/>	<input type="checkbox"/>	<input type="checkbox"/>																																												
e. pelletsovn	<input type="checkbox"/>	<input type="checkbox"/>	<input type="checkbox"/>	<input type="checkbox"/>	<input type="checkbox"/>																																												
f. andre:	<input type="checkbox"/>	<input type="checkbox"/>	<input type="checkbox"/>	<input type="checkbox"/>	<input type="checkbox"/>																																												
4. Hvilke(t) oppvarmingssystem benytter du nå? (sett kryss ved	<input type="checkbox"/> elektrisk oppvarming <input type="checkbox"/> vedovn																																																

<p><u>samtlig</u>e alternativ som er relevante for deg)?</p>	<input type="checkbox"/> peis <input type="checkbox"/> varmepumpe <input type="checkbox"/> pelletsovn <input type="checkbox"/> andre:																																																
<p>5. Hvilket oppvarmingsystem bruker du det meste av tida? (sett bare <u>ett</u> kryss for hovedoppvarmingsystemet)</p>	<input type="checkbox"/> elektrisk oppvarming <input type="checkbox"/> vedovn <input type="checkbox"/> peis <input type="checkbox"/> varmepumpe <input type="checkbox"/> pelletsovn <input type="checkbox"/> andre:																																																
<p>6. Hvor fornøyd er du med ditt(dine) eksisterende oppvarmings-system(er)?</p> <p>a. elektrisk oppvarming</p> <p>b. vedovn</p> <p>c. peis</p> <p>d. varmepumpe</p> <p>e. pelletsovn</p> <p>f. andre:</p>	<table border="1"> <thead> <tr> <th></th> <th colspan="2">veldig misfornøyd</th> <th colspan="2"></th> <th>veldig fornøyd</th> </tr> <tr> <th></th> <th>1</th> <th>2</th> <th>3</th> <th>4</th> <th>5</th> </tr> </thead> <tbody> <tr> <td>a. elektrisk oppvarming</td> <td><input type="checkbox"/></td> <td><input type="checkbox"/></td> <td><input type="checkbox"/></td> <td><input type="checkbox"/></td> <td><input type="checkbox"/></td> </tr> <tr> <td>b. vedovn</td> <td><input type="checkbox"/></td> <td><input type="checkbox"/></td> <td><input type="checkbox"/></td> <td><input type="checkbox"/></td> <td><input type="checkbox"/></td> </tr> <tr> <td>c. peis</td> <td><input type="checkbox"/></td> <td><input type="checkbox"/></td> <td><input type="checkbox"/></td> <td><input type="checkbox"/></td> <td><input type="checkbox"/></td> </tr> <tr> <td>d. varmepumpe</td> <td><input type="checkbox"/></td> <td><input type="checkbox"/></td> <td><input type="checkbox"/></td> <td><input type="checkbox"/></td> <td><input type="checkbox"/></td> </tr> <tr> <td>e. pelletsovn</td> <td><input type="checkbox"/></td> <td><input type="checkbox"/></td> <td><input type="checkbox"/></td> <td><input type="checkbox"/></td> <td><input type="checkbox"/></td> </tr> <tr> <td>f. andre:</td> <td><input type="checkbox"/></td> <td><input type="checkbox"/></td> <td><input type="checkbox"/></td> <td><input type="checkbox"/></td> <td><input type="checkbox"/></td> </tr> </tbody> </table>		veldig misfornøyd				veldig fornøyd		1	2	3	4	5	a. elektrisk oppvarming	<input type="checkbox"/>	<input type="checkbox"/>	<input type="checkbox"/>	<input type="checkbox"/>	<input type="checkbox"/>	b. vedovn	<input type="checkbox"/>	<input type="checkbox"/>	<input type="checkbox"/>	<input type="checkbox"/>	<input type="checkbox"/>	c. peis	<input type="checkbox"/>	<input type="checkbox"/>	<input type="checkbox"/>	<input type="checkbox"/>	<input type="checkbox"/>	d. varmepumpe	<input type="checkbox"/>	<input type="checkbox"/>	<input type="checkbox"/>	<input type="checkbox"/>	<input type="checkbox"/>	e. pelletsovn	<input type="checkbox"/>	<input type="checkbox"/>	<input type="checkbox"/>	<input type="checkbox"/>	<input type="checkbox"/>	f. andre:	<input type="checkbox"/>	<input type="checkbox"/>	<input type="checkbox"/>	<input type="checkbox"/>	<input type="checkbox"/>
	veldig misfornøyd				veldig fornøyd																																												
	1	2	3	4	5																																												
a. elektrisk oppvarming	<input type="checkbox"/>	<input type="checkbox"/>	<input type="checkbox"/>	<input type="checkbox"/>	<input type="checkbox"/>																																												
b. vedovn	<input type="checkbox"/>	<input type="checkbox"/>	<input type="checkbox"/>	<input type="checkbox"/>	<input type="checkbox"/>																																												
c. peis	<input type="checkbox"/>	<input type="checkbox"/>	<input type="checkbox"/>	<input type="checkbox"/>	<input type="checkbox"/>																																												
d. varmepumpe	<input type="checkbox"/>	<input type="checkbox"/>	<input type="checkbox"/>	<input type="checkbox"/>	<input type="checkbox"/>																																												
e. pelletsovn	<input type="checkbox"/>	<input type="checkbox"/>	<input type="checkbox"/>	<input type="checkbox"/>	<input type="checkbox"/>																																												
f. andre:	<input type="checkbox"/>	<input type="checkbox"/>	<input type="checkbox"/>	<input type="checkbox"/>	<input type="checkbox"/>																																												
<p>7. Om du ikke er fornøyd med din(e) eksisterende oppvarmings-system(er), ønsker du da å installere et nytt?</p>	<input type="checkbox"/> ja <input type="checkbox"/> nei, oppgi grunnen/årsak																																																
<p>8. Hva var / ville være en grunn for å endre ditt oppvarmings-system (sett kryss ved alle relevante alternativer)?</p>	<input type="checkbox"/> eksisterende oppvarmings-system er ødelagt <input type="checkbox"/> eksisterende oppvarmings-system er for gammelt <input type="checkbox"/> høye brenselkostnader <input type="checkbox"/> høye vedlikeholdskostnader <input type="checkbox"/> flytting til en ny bolig <input type="checkbox"/> oppussing bolig <input type="checkbox"/> andre:																																																
<p>9. Hvilket oppvarmings-system vil du velge hvis du bestemmer deg for å bytte ut ditt gamle oppvarmings-system (sett kryss ved bare <u>ett</u> alternativ)?</p>	<input type="checkbox"/> elektrisk oppvarming <input type="checkbox"/> vedovn <input type="checkbox"/> peis <input type="checkbox"/> varmepumpe <input type="checkbox"/> pelletsovn, gå til spørsmål 12 <input type="checkbox"/> andre:																																																
<p>10. Hvilke av disse er / ville være de tre viktigste faktorene som</p>	<input type="checkbox"/> høye installeringskostnader <input type="checkbox"/> høye driftskostnader																																																

<p>hindrer deg fra å velge pelletsovn (sett kryss bare ved <u>tre</u> alternativer)?</p>	<input type="checkbox"/> mye arbeid <input type="checkbox"/> upålitelig <input type="checkbox"/> usikker tilgang til brensel <input type="checkbox"/> lav innendørs luftkvalitet <input type="checkbox"/> mangel på informasjon <input type="checkbox"/> ingen anbefaler den til meg <input type="checkbox"/> lav markedsandel <input type="checkbox"/> mangel på teknologi <input type="checkbox"/> vanskeligheter med å etablere pelletslager og håndtering av pellets <input type="checkbox"/> mangel på tilgang til service og støtte for oppvarmingssystemet <input type="checkbox"/> andre:																																																															
<p>11. Ville du vurdere å installere pelletsovn hvis den var subsidiert (ca. NOK 4 000) ?</p>	<input type="checkbox"/> ja <input type="checkbox"/> nei <input type="checkbox"/> vet ikke																																																															
<p>12. Leter du aktivt etter informasjon om alternative oppvarmingssystemer?</p>	<input type="checkbox"/> ja <input type="checkbox"/> nei, gå til spørsmål 14																																																															
<p>13. Hvor viktig er de følgende informasjonskildene for deg når du leter etter informasjon om oppvarmingssystem? Velg informasjons kilden(ene) som er relevant(e) til deg.</p> <p>a. avis/blad</p> <p>b. internet</p> <p>c. venner/familie</p> <p>d. leverandør</p> <p>e. flygebrev/informasjonsavis</p> <p>f. andre:</p>	<table border="0"> <tr> <td></td> <td style="text-align: center;">ikke viktig</td> <td></td> <td></td> <td></td> <td></td> <td style="text-align: center;">veldig viktig</td> </tr> <tr> <td></td> <td style="text-align: center;">1</td> <td style="text-align: center;">2</td> <td style="text-align: center;">3</td> <td style="text-align: center;">4</td> <td style="text-align: center;">5</td> <td></td> </tr> <tr> <td></td> <td style="text-align: center;"><input type="checkbox"/></td> <td style="text-align: center;"><input type="checkbox"/></td> <td style="text-align: center;"><input type="checkbox"/></td> <td style="text-align: center;"><input type="checkbox"/></td> <td style="text-align: center;"><input type="checkbox"/></td> <td></td> </tr> <tr> <td>a.</td> <td style="text-align: center;"><input type="checkbox"/></td> <td style="text-align: center;"><input type="checkbox"/></td> <td style="text-align: center;"><input type="checkbox"/></td> <td style="text-align: center;"><input type="checkbox"/></td> <td style="text-align: center;"><input type="checkbox"/></td> <td></td> </tr> <tr> <td>b.</td> <td style="text-align: center;"><input type="checkbox"/></td> <td style="text-align: center;"><input type="checkbox"/></td> <td style="text-align: center;"><input type="checkbox"/></td> <td style="text-align: center;"><input type="checkbox"/></td> <td style="text-align: center;"><input type="checkbox"/></td> <td></td> </tr> <tr> <td>c.</td> <td style="text-align: center;"><input type="checkbox"/></td> <td style="text-align: center;"><input type="checkbox"/></td> <td style="text-align: center;"><input type="checkbox"/></td> <td style="text-align: center;"><input type="checkbox"/></td> <td style="text-align: center;"><input type="checkbox"/></td> <td></td> </tr> <tr> <td>d.</td> <td style="text-align: center;"><input type="checkbox"/></td> <td style="text-align: center;"><input type="checkbox"/></td> <td style="text-align: center;"><input type="checkbox"/></td> <td style="text-align: center;"><input type="checkbox"/></td> <td style="text-align: center;"><input type="checkbox"/></td> <td></td> </tr> <tr> <td>e.</td> <td style="text-align: center;"><input type="checkbox"/></td> <td style="text-align: center;"><input type="checkbox"/></td> <td style="text-align: center;"><input type="checkbox"/></td> <td style="text-align: center;"><input type="checkbox"/></td> <td style="text-align: center;"><input type="checkbox"/></td> <td></td> </tr> <tr> <td>f.</td> <td style="text-align: center;"><input type="checkbox"/></td> <td style="text-align: center;"><input type="checkbox"/></td> <td style="text-align: center;"><input type="checkbox"/></td> <td style="text-align: center;"><input type="checkbox"/></td> <td style="text-align: center;"><input type="checkbox"/></td> <td></td> </tr> </table>		ikke viktig					veldig viktig		1	2	3	4	5			<input type="checkbox"/>	<input type="checkbox"/>	<input type="checkbox"/>	<input type="checkbox"/>	<input type="checkbox"/>		a.	<input type="checkbox"/>	<input type="checkbox"/>	<input type="checkbox"/>	<input type="checkbox"/>	<input type="checkbox"/>		b.	<input type="checkbox"/>	<input type="checkbox"/>	<input type="checkbox"/>	<input type="checkbox"/>	<input type="checkbox"/>		c.	<input type="checkbox"/>	<input type="checkbox"/>	<input type="checkbox"/>	<input type="checkbox"/>	<input type="checkbox"/>		d.	<input type="checkbox"/>	<input type="checkbox"/>	<input type="checkbox"/>	<input type="checkbox"/>	<input type="checkbox"/>		e.	<input type="checkbox"/>	<input type="checkbox"/>	<input type="checkbox"/>	<input type="checkbox"/>	<input type="checkbox"/>		f.	<input type="checkbox"/>	<input type="checkbox"/>	<input type="checkbox"/>	<input type="checkbox"/>	<input type="checkbox"/>	
	ikke viktig					veldig viktig																																																										
	1	2	3	4	5																																																											
	<input type="checkbox"/>	<input type="checkbox"/>	<input type="checkbox"/>	<input type="checkbox"/>	<input type="checkbox"/>																																																											
a.	<input type="checkbox"/>	<input type="checkbox"/>	<input type="checkbox"/>	<input type="checkbox"/>	<input type="checkbox"/>																																																											
b.	<input type="checkbox"/>	<input type="checkbox"/>	<input type="checkbox"/>	<input type="checkbox"/>	<input type="checkbox"/>																																																											
c.	<input type="checkbox"/>	<input type="checkbox"/>	<input type="checkbox"/>	<input type="checkbox"/>	<input type="checkbox"/>																																																											
d.	<input type="checkbox"/>	<input type="checkbox"/>	<input type="checkbox"/>	<input type="checkbox"/>	<input type="checkbox"/>																																																											
e.	<input type="checkbox"/>	<input type="checkbox"/>	<input type="checkbox"/>	<input type="checkbox"/>	<input type="checkbox"/>																																																											
f.	<input type="checkbox"/>	<input type="checkbox"/>	<input type="checkbox"/>	<input type="checkbox"/>	<input type="checkbox"/>																																																											
<p>14. Hvordan avgjør/avgjorde du ditt valg av oppvarmingssystem (velg alternativet som passer din strategi best)?</p>	<input type="checkbox"/> kjøper det samme oppvarmingssystem som før <input type="checkbox"/> vurderer alle oppvarmingssystemer for å oppnå maksimal nytteverdi <input type="checkbox"/> velger oppvarmingssystem som har den største andel blant mine naboer/venner																																																															

	<input type="checkbox"/> sammenligner det oppvarmingssystem som er anvendt mest blant mine naboer og mitt foregående oppvarmingssystem, og velger det beste																																																								
15. Hvor betydningsfullt er et oppvarmingssystems egenskaper basert på din erfaring?	<table border="1"> <thead> <tr> <th></th> <th>ikke viktig</th> <th>1</th> <th>2</th> <th>3</th> <th>4</th> <th>5</th> <th>veldig viktig</th> </tr> </thead> <tbody> <tr> <td>a. funksjonsstabilitet</td> <td><input type="checkbox"/></td> <td><input type="checkbox"/></td> <td><input type="checkbox"/></td> <td><input type="checkbox"/></td> <td><input type="checkbox"/></td> <td><input type="checkbox"/></td> <td><input type="checkbox"/></td> </tr> <tr> <td>b. innendørs luftkvalitet</td> <td><input type="checkbox"/></td> <td><input type="checkbox"/></td> <td><input type="checkbox"/></td> <td><input type="checkbox"/></td> <td><input type="checkbox"/></td> <td><input type="checkbox"/></td> <td><input type="checkbox"/></td> </tr> <tr> <td>c. investeringskostnader</td> <td><input type="checkbox"/></td> <td><input type="checkbox"/></td> <td><input type="checkbox"/></td> <td><input type="checkbox"/></td> <td><input type="checkbox"/></td> <td><input type="checkbox"/></td> <td><input type="checkbox"/></td> </tr> <tr> <td>d. driftskostnader</td> <td><input type="checkbox"/></td> <td><input type="checkbox"/></td> <td><input type="checkbox"/></td> <td><input type="checkbox"/></td> <td><input type="checkbox"/></td> <td><input type="checkbox"/></td> <td><input type="checkbox"/></td> </tr> <tr> <td>e. drift- og vedlikeholdsarbeid</td> <td><input type="checkbox"/></td> <td><input type="checkbox"/></td> <td><input type="checkbox"/></td> <td><input type="checkbox"/></td> <td><input type="checkbox"/></td> <td><input type="checkbox"/></td> <td><input type="checkbox"/></td> </tr> <tr> <td>f. sikker tilgang på brensel</td> <td><input type="checkbox"/></td> <td><input type="checkbox"/></td> <td><input type="checkbox"/></td> <td><input type="checkbox"/></td> <td><input type="checkbox"/></td> <td><input type="checkbox"/></td> <td><input type="checkbox"/></td> </tr> </tbody> </table>		ikke viktig	1	2	3	4	5	veldig viktig	a. funksjonsstabilitet	<input type="checkbox"/>	<input type="checkbox"/>	<input type="checkbox"/>	<input type="checkbox"/>	<input type="checkbox"/>	<input type="checkbox"/>	<input type="checkbox"/>	b. innendørs luftkvalitet	<input type="checkbox"/>	<input type="checkbox"/>	<input type="checkbox"/>	<input type="checkbox"/>	<input type="checkbox"/>	<input type="checkbox"/>	<input type="checkbox"/>	c. investeringskostnader	<input type="checkbox"/>	<input type="checkbox"/>	<input type="checkbox"/>	<input type="checkbox"/>	<input type="checkbox"/>	<input type="checkbox"/>	<input type="checkbox"/>	d. driftskostnader	<input type="checkbox"/>	<input type="checkbox"/>	<input type="checkbox"/>	<input type="checkbox"/>	<input type="checkbox"/>	<input type="checkbox"/>	<input type="checkbox"/>	e. drift- og vedlikeholdsarbeid	<input type="checkbox"/>	<input type="checkbox"/>	<input type="checkbox"/>	<input type="checkbox"/>	<input type="checkbox"/>	<input type="checkbox"/>	<input type="checkbox"/>	f. sikker tilgang på brensel	<input type="checkbox"/>	<input type="checkbox"/>	<input type="checkbox"/>	<input type="checkbox"/>	<input type="checkbox"/>	<input type="checkbox"/>	<input type="checkbox"/>
	ikke viktig	1	2	3	4	5	veldig viktig																																																		
a. funksjonsstabilitet	<input type="checkbox"/>	<input type="checkbox"/>	<input type="checkbox"/>	<input type="checkbox"/>	<input type="checkbox"/>	<input type="checkbox"/>	<input type="checkbox"/>																																																		
b. innendørs luftkvalitet	<input type="checkbox"/>	<input type="checkbox"/>	<input type="checkbox"/>	<input type="checkbox"/>	<input type="checkbox"/>	<input type="checkbox"/>	<input type="checkbox"/>																																																		
c. investeringskostnader	<input type="checkbox"/>	<input type="checkbox"/>	<input type="checkbox"/>	<input type="checkbox"/>	<input type="checkbox"/>	<input type="checkbox"/>	<input type="checkbox"/>																																																		
d. driftskostnader	<input type="checkbox"/>	<input type="checkbox"/>	<input type="checkbox"/>	<input type="checkbox"/>	<input type="checkbox"/>	<input type="checkbox"/>	<input type="checkbox"/>																																																		
e. drift- og vedlikeholdsarbeid	<input type="checkbox"/>	<input type="checkbox"/>	<input type="checkbox"/>	<input type="checkbox"/>	<input type="checkbox"/>	<input type="checkbox"/>	<input type="checkbox"/>																																																		
f. sikker tilgang på brensel	<input type="checkbox"/>	<input type="checkbox"/>	<input type="checkbox"/>	<input type="checkbox"/>	<input type="checkbox"/>	<input type="checkbox"/>	<input type="checkbox"/>																																																		
16. I hvor stor grad påvirkes ditt valg av oppvarmingssystem av andre mennesker? Anslå innvirkningen fra andre mennesker på din beslutning. Vanligvis finnes noe påvirkning fra andre mennesker. 0% betyr at din beslutning er helt uavhengig av andre menneskers påvirkning, 100% betyr at du tar din bestemmelse bare på grunnlag av andres meninger.	<input type="checkbox"/> 0 % <input type="checkbox"/> 20 % <input type="checkbox"/> 40 % <input type="checkbox"/> 60 % <input type="checkbox"/> 80 % <input type="checkbox"/> 100 %																																																								
17. Hvorfor skiftet du til pelletsovn?	<input type="checkbox"/> miljøvennlig oppvarmingssystem <input type="checkbox"/> stabile pelletspriser <input type="checkbox"/> stønad <input type="checkbox"/> økt behov for oppvarming <input type="checkbox"/> lave driftskostnader <input type="checkbox"/> økte elektrisitetspriser <input type="checkbox"/> andre:																																																								
18. Hvilke fordeler fikk du ved å benytte pelletsovn?	<input type="checkbox"/> penger spart <input type="checkbox"/> pålitelig <input type="checkbox"/> miljøvennlig <input type="checkbox"/> andre:																																																								
19. Gjorde du omfattende vurderinger før du besluttet å bruke pelletsovn?	<input type="checkbox"/> ja <input type="checkbox"/> nei, gå til Del D																																																								

	a. elektrisk oppvarming	<input type="checkbox"/>	<input type="checkbox"/>	<input type="checkbox"/>	<input type="checkbox"/>	<input type="checkbox"/>	<input type="checkbox"/>	<input type="checkbox"/>
	b. varmepumpe	<input type="checkbox"/>	<input type="checkbox"/>	<input type="checkbox"/>	<input type="checkbox"/>	<input type="checkbox"/>	<input type="checkbox"/>	<input type="checkbox"/>
	c. pelletsovn	<input type="checkbox"/>	<input type="checkbox"/>	<input type="checkbox"/>	<input type="checkbox"/>	<input type="checkbox"/>	<input type="checkbox"/>	<input type="checkbox"/>
7.	Hvis jeg ønsket kunne jeg lett bruke denne typen oppvarmingssystem	helt uenig						helt enig
		1	2	3	4	5	6	7
	a. elektrisk oppvarming	<input type="checkbox"/>	<input type="checkbox"/>	<input type="checkbox"/>	<input type="checkbox"/>	<input type="checkbox"/>	<input type="checkbox"/>	<input type="checkbox"/>
	b. varmepumpe	<input type="checkbox"/>	<input type="checkbox"/>	<input type="checkbox"/>	<input type="checkbox"/>	<input type="checkbox"/>	<input type="checkbox"/>	<input type="checkbox"/>
	c. pelletsovn	<input type="checkbox"/>	<input type="checkbox"/>	<input type="checkbox"/>	<input type="checkbox"/>	<input type="checkbox"/>	<input type="checkbox"/>	<input type="checkbox"/>
8.	Jeg tror at denne typen oppvarmingssystem har høyere driftssikkerhet	helt uenig						helt enig
		1	2	3	4	5	6	7
	a. elektrisk oppvarming	<input type="checkbox"/>	<input type="checkbox"/>	<input type="checkbox"/>	<input type="checkbox"/>	<input type="checkbox"/>	<input type="checkbox"/>	<input type="checkbox"/>
	b. varmepumpe	<input type="checkbox"/>	<input type="checkbox"/>	<input type="checkbox"/>	<input type="checkbox"/>	<input type="checkbox"/>	<input type="checkbox"/>	<input type="checkbox"/>
	c. pelletsovn	<input type="checkbox"/>	<input type="checkbox"/>	<input type="checkbox"/>	<input type="checkbox"/>	<input type="checkbox"/>	<input type="checkbox"/>	<input type="checkbox"/>
9.	Dårlig inneluftkvalitet er forårsaket av denne typen oppvarmingssystem	helt uenig						helt enig
		1	2	3	4	5	6	7
	a. elektrisk oppvarming	<input type="checkbox"/>	<input type="checkbox"/>	<input type="checkbox"/>	<input type="checkbox"/>	<input type="checkbox"/>	<input type="checkbox"/>	<input type="checkbox"/>
	b. varmepumpe	<input type="checkbox"/>	<input type="checkbox"/>	<input type="checkbox"/>	<input type="checkbox"/>	<input type="checkbox"/>	<input type="checkbox"/>	<input type="checkbox"/>
	c. pelletsovn	<input type="checkbox"/>	<input type="checkbox"/>	<input type="checkbox"/>	<input type="checkbox"/>	<input type="checkbox"/>	<input type="checkbox"/>	<input type="checkbox"/>
10.	Denne typen oppvarmingssystem er for kostbart	helt uenig						helt enig
		1	2	3	4	5	6	7
	a. elektrisk oppvarming	<input type="checkbox"/>	<input type="checkbox"/>	<input type="checkbox"/>	<input type="checkbox"/>	<input type="checkbox"/>	<input type="checkbox"/>	<input type="checkbox"/>
	b. varmepumpe	<input type="checkbox"/>	<input type="checkbox"/>	<input type="checkbox"/>	<input type="checkbox"/>	<input type="checkbox"/>	<input type="checkbox"/>	<input type="checkbox"/>
	c. pelletsovn	<input type="checkbox"/>	<input type="checkbox"/>	<input type="checkbox"/>	<input type="checkbox"/>	<input type="checkbox"/>	<input type="checkbox"/>	<input type="checkbox"/>
11.	Jeg ville være nødt til å gjøre en masse drifts- og vedlikeholdsarbeider hvis jeg bruker denne typen av oppvarmingssystem	helt uenig						helt enig
		1	2	3	4	5	6	7
	a. elektrisk oppvarming	<input type="checkbox"/>	<input type="checkbox"/>	<input type="checkbox"/>	<input type="checkbox"/>	<input type="checkbox"/>	<input type="checkbox"/>	<input type="checkbox"/>
	b. varmepumpe	<input type="checkbox"/>	<input type="checkbox"/>	<input type="checkbox"/>	<input type="checkbox"/>	<input type="checkbox"/>	<input type="checkbox"/>	<input type="checkbox"/>
	c. pelletsovn	<input type="checkbox"/>	<input type="checkbox"/>	<input type="checkbox"/>	<input type="checkbox"/>	<input type="checkbox"/>	<input type="checkbox"/>	<input type="checkbox"/>
12.	Denne type oppvarmingssystem har stabile priser på brensel/energi.	helt uenig						helt enig

c. pelletsovn									
19.	Jeg tror at denne typen av oppvarmingssystem ville koste mer enn jeg har råd til	helt uenig						helt enig	
		1	2	3	4	5	6	7	
		a. elektrisk oppvarming	<input type="checkbox"/>	<input type="checkbox"/>	<input type="checkbox"/>	<input type="checkbox"/>	<input type="checkbox"/>	<input type="checkbox"/>	<input type="checkbox"/>
		b. varmepumpe	<input type="checkbox"/>	<input type="checkbox"/>	<input type="checkbox"/>	<input type="checkbox"/>	<input type="checkbox"/>	<input type="checkbox"/>	<input type="checkbox"/>
	c. pelletsovn	<input type="checkbox"/>	<input type="checkbox"/>	<input type="checkbox"/>	<input type="checkbox"/>	<input type="checkbox"/>	<input type="checkbox"/>		
20.	Det er mye arbeid knyttet til denne typen av oppvarmingssystem	helt uenig						helt enig	
		1	2	3	4	5	6	7	
		a. elektrisk oppvarming	<input type="checkbox"/>	<input type="checkbox"/>	<input type="checkbox"/>	<input type="checkbox"/>	<input type="checkbox"/>	<input type="checkbox"/>	<input type="checkbox"/>
		b. varmepumpe	<input type="checkbox"/>	<input type="checkbox"/>	<input type="checkbox"/>	<input type="checkbox"/>	<input type="checkbox"/>	<input type="checkbox"/>	<input type="checkbox"/>
	c. pelletsovn	<input type="checkbox"/>	<input type="checkbox"/>	<input type="checkbox"/>	<input type="checkbox"/>	<input type="checkbox"/>	<input type="checkbox"/>		
21.	Prisnivået er stabilt for denne typen av oppvarmingssystem	helt uenig						helt enig	
		1	2	3	4	5	6	7	
		a. elektrisk oppvarming	<input type="checkbox"/>	<input type="checkbox"/>	<input type="checkbox"/>	<input type="checkbox"/>	<input type="checkbox"/>	<input type="checkbox"/>	<input type="checkbox"/>
		b. varmepumpe	<input type="checkbox"/>	<input type="checkbox"/>	<input type="checkbox"/>	<input type="checkbox"/>	<input type="checkbox"/>	<input type="checkbox"/>	<input type="checkbox"/>
	c. pelletsovn	<input type="checkbox"/>	<input type="checkbox"/>	<input type="checkbox"/>	<input type="checkbox"/>	<input type="checkbox"/>	<input type="checkbox"/>		

DEL – E

De følgende spørsmålene vurderer din personlige mening vedrørende miljø og samfunn. Det er ikke rette eller gale svar. Sett ett kryss (X) på en skala mellom 1 og 5 i samsvar med din mening.

		helt uenig					helt enig
		1	2	3	4	5	
1.	Menneskeheten må leve i pakt med naturen for å overleve på sikt	<input type="checkbox"/>	<input type="checkbox"/>	<input type="checkbox"/>	<input type="checkbox"/>	<input type="checkbox"/>	
2.	Menneskeheten overforbruker naturressursene	<input type="checkbox"/>	<input type="checkbox"/>	<input type="checkbox"/>	<input type="checkbox"/>	<input type="checkbox"/>	
3.	Jorden er som et romskip med begrensede ressurser og plass	<input type="checkbox"/>	<input type="checkbox"/>	<input type="checkbox"/>	<input type="checkbox"/>	<input type="checkbox"/>	

4.	Det finnes en grense for vekst som vårt industrialiserte samfunn ikke må overskride	<input type="checkbox"/>	<input type="checkbox"/>	<input type="checkbox"/>	<input type="checkbox"/>	<input type="checkbox"/>
5.	Menneskeheten er skapt for å kontrollere resten av naturen	<input type="checkbox"/>	<input type="checkbox"/>	<input type="checkbox"/>	<input type="checkbox"/>	<input type="checkbox"/>
6.	Planter og dyr eksisterer hovedsakelig for å bli forbrukt av mennesker	<input type="checkbox"/>	<input type="checkbox"/>	<input type="checkbox"/>	<input type="checkbox"/>	<input type="checkbox"/>

<u>Hvordan burde vårt samfunn se ut?</u>		helt uenig		helt enig		
		1	2	3	4	5
1.	Et samfunn som gir høyere prioritet til miljømessige hensyn enn til økonomisk utvikling	<input type="checkbox"/>	<input type="checkbox"/>	<input type="checkbox"/>	<input type="checkbox"/>	<input type="checkbox"/>
2.	Et samfunn som prøver å danne velstand men ikke på bekostning av miljømessig risiko	<input type="checkbox"/>	<input type="checkbox"/>	<input type="checkbox"/>	<input type="checkbox"/>	<input type="checkbox"/>
3.	Et samfunn som legger vekt på arbeidsgleden som det mest positive av menneskelig velvære	<input type="checkbox"/>	<input type="checkbox"/>	<input type="checkbox"/>	<input type="checkbox"/>	<input type="checkbox"/>
4.	Et samfunn der en person dømmes hovedsaklig på basis av ens menneskelige egenskaper	<input type="checkbox"/>	<input type="checkbox"/>	<input type="checkbox"/>	<input type="checkbox"/>	<input type="checkbox"/>
5.	Et samfunn som har mange muligheter for en innbygger til å delta i de politiske prosesser	<input type="checkbox"/>	<input type="checkbox"/>	<input type="checkbox"/>	<input type="checkbox"/>	<input type="checkbox"/>
6.	Et samfunn som anstrenger seg for å beholde naturen som den er	<input type="checkbox"/>	<input type="checkbox"/>	<input type="checkbox"/>	<input type="checkbox"/>	<input type="checkbox"/>

Du er velkommen å skrive kommentarer ut over det som er gitt i spørreskjemaet i følgende rubrikk:

DEL – F

De følgende spørsmålene er rene tekniske spørsmål om dine erfaringer med bruk av trepellets.

		helt uenig					helt enig
		1	2	3	4	5	
1.	Jeg har brukt mer tid enn forventet til drift/vedlikehold på å bruke pellets som brensel	<input type="checkbox"/>	<input type="checkbox"/>	<input type="checkbox"/>	<input type="checkbox"/>	<input type="checkbox"/>	
2.	Hvor mange timer pr. uke bruker du på drift/vedlikehold?minutter pr. uke					
3.	Jeg er veldig fornøyd med kaminen/kjelen som jeg bruker til å fyre med pellets	<input type="checkbox"/>	<input type="checkbox"/>	<input type="checkbox"/>	<input type="checkbox"/>	<input type="checkbox"/>	
4.	Hvis det har vært problemer med kaminen/kjelen, hva har vært det største problemet?(fyll ut)					
5.	Jeg er veldig fornøyd med leverandøren av kaminen/kjelen min	<input type="checkbox"/>	<input type="checkbox"/>	<input type="checkbox"/>	<input type="checkbox"/>	<input type="checkbox"/>	
6.	Hvis det har vært problemer med leverandøren av kaminen/kjelen, hva har vært det største problemet? (fyll ut)					
7.	Jeg er veldig fornøyd med kvaliteten på pellets (brenselet)	<input type="checkbox"/>	<input type="checkbox"/>	<input type="checkbox"/>	<input type="checkbox"/>	<input type="checkbox"/>	
8.	Hvis det har vært problemer med pelletskvaliteten, hva har vært det største problemet? (fyll ut)					

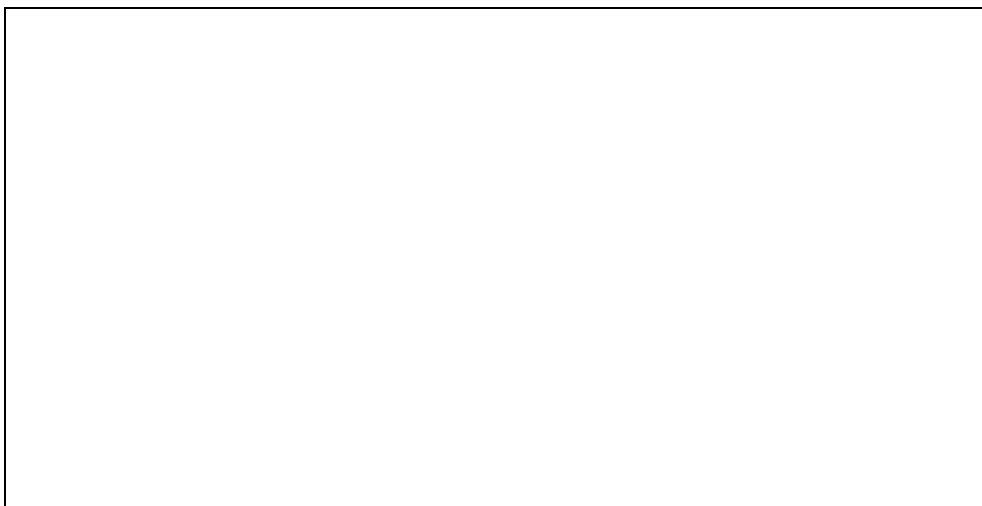

Tusen takk at du besvarte dette spørreskjemaet !

APPENDIX B

- B.1. Sopha, B. M., Klöckner, C. A. and Hertwich, E.G., 2010. Adopter and non-adopters of wood pellet heating in Norway, *Biomass and Bioenergy* 2011: 35(1) 652-662
- B.2. Sopha, B. M. and Klöckner, C. A., 2010. Psychological factors in the diffusion of sustainable technology: A study of Norwegian households' adoption of wood pellet heating, submitted to *Renewable & Sustainable Energy Reviews*
- B.3. Sopha, B. M., Klöckner, C. A., Skjevraak, G. and Hertwich, E.G., Norwegian households' perception of wood pellet stove compared to air-to-air heat pump and electric heating, *Energy Policy* 2010: 38(7), 3744-3754
- B.4. Sopha, B. M., Klöckner, C. A. and Hertwich, E.G., 2010. Modeling adoption and diffusion of heating system in Norway: Coupling agent-based modeling with empirical research, submitted to *Environmental Modelling and Software*
- B.5. Sopha, B. M., Klöckner, C. A. and Hertwich, E.G., 2010. The influence of the social network structure on the diffusion of heating system in Norway. In Ernst, A. and Kuhn, S. (Eds) 2010. *Proceeding of 3th World Congress on Social Simulation WCSS 2010*, Kassel, Germany: Center for Environmental Systems Research, University of Kassel.
- B.6. Sopha, B. M., Klöckner, C. A. and Hertwich, E.G., 2010. Exploring policy options for a transition to sustainable heating system diffusion using an Agent-Based Simulation, accepted in *Energy Policy* 2011
- B.7. Sopha, B. M., Fet, A. M., Keitsch, M. M., and Haskins, C., Using systems engineering to create a framework for evaluating industrial symbiosis options, *Systems Engineering* 2010: 13(2), 149-160

Adopter and Non-Adopters of Wood Pellet Heating in Norway

Bertha Maya Sopha

*Industrial Ecology Programme and Department of Energy and Process Engineering
Norwegian University of Science and Technology
N-7491 Trondheim, Norway*

Christian A. Klöckner

*Department of Psychology, Section for Risk Psychology, Environment and Safety
(RIPENSA)
Norwegian University of Science and Technology
N-7491 Trondheim, Norway*

Edgar G. Hertwich

*Industrial Ecology Programme and Department of Energy and Process Engineering
Norwegian University of Science and Technology
N-7491 Trondheim, Norway*

Biomass and Bioenergy, Vol. 35, Issue 1, 2011



ELSEVIER

Available at www.sciencedirect.com<http://www.elsevier.com/locate/biombioe>

Adopters and non-adopters of wood pellet heating in Norwegian households

Bertha Maya Sopha^{a,*}, Christian A. Klöckner^b, Edgar G. Hertwich^a

^a Industrial Ecology Programme and Department of Energy and Process Engineering, Norwegian University of Science and Technology, NO-7491 Trondheim, Norway

^b Department of Psychology, Section for Risk Psychology, Environment and Safety (RIPENSA), Norwegian University of Science and Technology, NO-7491 Trondheim, Norway

ARTICLE INFO

Article history:

Received 26 February 2010

Received in revised form

5 October 2010

Accepted 18 October 2010

Available online 11 November 2010

Keywords:

Adopters

Non-adopters

Wood pellet heating

Norwegian households

Perceived barriers

Required subsidy

ABSTRACT

The aim of the present paper is to understand the differences between adopters and non-adopters of wood pellet heating in Norwegian households by comparing the two groups with regard to key points of adoption. A mail survey of 669 adopters and 291 non-adopters of wood pellet heating was conducted in 2008. Results indicate that there are significant differences between groups with respect to socio-demographic factors, decision-related factors, heating systems adopted and reasons for shifting heating systems. The results also indicate that the adopter group shows characteristics of early adopters, whereas the non-adopter group has characteristics of late adopters. The results for levels of income and education contradict what would be predicted from theory, however. Both groups show no significant difference with respect to values, but the perception of which heating system is the most environmentally friendly differs significantly. The top three reasons cited by the adopter group for installing wood pellet heating are getting an environmentally friendly heating system, low operation costs and an anticipated increase in electricity prices. According to the non-adopter group, the main barriers to adoption are high installation costs, followed by the difficulties of refitting the house for wood pellet heating. A higher subsidy (i.e., an average of 64% of the total installation cost) rather than the current subsidy of up to 20% was required by the non-adopter group to switch to wood pellet heating.

© 2010 Elsevier Ltd. All rights reserved.

1. Introduction

Hydropower construction by publicly owned utilities from 1960 to 1990 resulted in a long period of low electricity prices for Norwegian households. Homeowners thus have used electricity as their main heating source for many years. However, high electricity prices have prompted households to search for alternative heating systems to reduce their electricity consumption. The Norwegian government has undertaken several policy measures to promote environmentally

friendly heating systems. One such action was the creation of Enova, which was established in 2001 as a public enterprise owned by the OED (Ministry of Petroleum and Energy) and designed to promote environmentally friendly energy restructuring of energy consumption and generation in Norway. Enova offers a subsidy scheme of up to 20% of total installation costs for wood pellet heating to reduce the use of oil-based heating systems together with reducing residential electricity consumption and dependency [1]. Reducing electricity consumption is also important for Norway because

* Corresponding author.

E-mail address: bertha.sopha@ntnu.no (B.M. Sopha).

0961-9534/\$ – see front matter © 2010 Elsevier Ltd. All rights reserved.

doi:10.1016/j.biombioe.2010.10.019

when energy consumption exceeds production, the reduced use of electricity can also reduce electricity imports, which are often generated from coal. Despite the subsidy, the market diffusion of wood pellet heating has hitherto been rather slow. It was reported that only 3 out of 1000 households were equipped with pellet stoves in 2006 (see Fig. 1) [2].

This paper presents an exploratory, descriptive study that attempts to understand the differences that exist between adopters and non-adopters of wood pellet heating in Norwegian households. The investigation does not consider the factors explaining the adoption of wood pellet heating, but focuses its attention on two aspects. First, it explores the differences between adopters and non-adopters with regard to some key points of adoption derived from different theories. Second, it identifies adopters' motivations for installing wood pellet heating, as well as the barriers perceived by non-adopters and the subsidies this group says it would need to shift to wood pellet heating.

There are at least two distinct motivations underlying this work. First, it represents an attempt to complement a previous study of bio-energy in Norway. Trømborg et al. [3] have already demonstrated the macro-level potential for bio-energy use in Norway, which makes an approach on a micro-level necessary, by addressing households as decision-makers in energy investments. Second, the goal was to examine, report on and contribute to the adoption of wood pellet heating in Norway. The market for wood pellets remains immature and the idea was to document households' perceptions of wood pellet heating to provide empirical evidence for policy makers. The research results from this study should be valuable in recognizing the heterogeneity of households so that policies encouraging wood pellet heating can be appropriately designed for different target groups.

2. Materials and methods

2.1. Sample

Data was collected through a questionnaire survey of 960 owners of single-family residences in the autumn of 2008. A

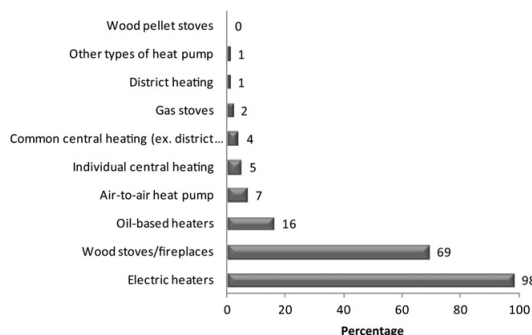

Fig. 1 – Heating systems adopted by Norwegian households in 2006, by percentage. Most of Norwegian households utilize more than one type heating system (Source: Statistics Norway [2]).

mail survey was chosen in order to obtain information on a national level. The original sample constituted of 1500 adopters and 1500 non-adopters. The adopter group represented almost the complete population of wood pellet adopters, whereas the non-adopter group represented households that had not installed wood pellet heating at the time of study and was selected with a random sample from the population register. Only homeowners were chosen as respondents since it is they who have the independent authority to make decisions regarding heating systems. The unit of analysis in the study was a household.

The questionnaires were sent by mail. After three weeks, the response rates of the adopter and non-adopter groups were 34.6% and 10.3%, respectively. A reminder letter resulted in a final response rate of 44.6% (669 responses) for the adopter group and 19.4% (291 responses) for the non-adopter group. Several respondents did not answer single questions in the questionnaire. For this reason the response rate varied for each question.

2.2. Measures

The questionnaire was organized into four parts. The first part encompassed general questions on socio-demographic factors, such as age, income, education and location. The second part addressed the respondents' communication habits about the choice of a heating system. The third part included questions related to decision-making strategies. Specific questions for the adopter group related to the motivation for installing wood pellet heating. Conversely, specific questions for the non-adopter group included perceived barriers and the level of subsidy required for wood pellet heating. The fourth part assessed the household's basic and environmental values and the perceived environmental benefit of a selection of heating systems. Basic values related to the degree of materialism/post-materialism were measured using items adapted from Vogel [4]. The New Environmental Paradigm (NEP) scale, which measures environmental values, was adopted from Lalonde and Jackson [5], who based their scale on original work by Dunlap and van Liere [6]. Each NEP subscale (balance of nature: NEP_{BON} ; limits to growth: NEP_{LTG} ; and human domination: NEP_{HD}) was measured by two items on a 5-point Likert scale.

3. Theoretical background

Understanding how individuals make decisions is important in order to be able to encourage pro-environmental consumer behavior. Decision-making has been extensively studied in economic, psychological and sociological research. An interdisciplinary approach aimed at deriving key points of adoption is addressed in this section, which outlines relevant theories about decision-making related to energy.

3.1. Diffusion of innovation

The diffusion of innovation theory [7] addresses how, why and at what rate innovation spreads. According to this theory, the characteristics of individuals, the type of innovation decisions, the communication channels used in the adoption process,

and the perceived attributes of innovations all affect the adoption rate. Rogers [7] came to the conclusion that an early adopter is generally younger, has more financial lucidity, has a higher social status, has an advanced education, searches more for information, has a closer contact to scientific sources and interacts with innovators, is more social and shows a higher degree of opinion leadership than a late adopter. To apply core elements of diffusion of innovation theory, adopters and non-adopters were compared with respect to age, income, education, information search, information source, and communication patterns.

Decisions are not only influenced by personal needs but also by social requirements. For instance, buying a car is not only undertaken to fulfill a need for transportation but also to obtain social identity and status. Jager [8] was able to demonstrate that social needs for belongingness and participation were important in explaining the purchase of photovoltaic systems. According to Rogers' theory, early adopters usually lean more towards their personal needs and have higher aspiration levels than late adopters [7].

Innovation attributes can explain 49–87% of the variance of adoption [7]. Numerous studies have also indicated that perceived innovation attributes play a crucial role in the adoption of wood pellet heating [9–11]. The present study therefore was designed to determine the subjective importance rather than the performance of each heating system with respect to these attributes in order to identify the information upon which households focused when making their choice.

3.2. Psychology

Psychological studies of pro-environmental behavior have demonstrated that pro-environmental behavior is anchored in value orientations. For example, Clark et al. [12] indicated that the bio-altruistic and pro-social values were significant factors in predicting participation rates in a green electricity scheme. Stern et al. [13] suggested that values were relevant determinants to explain the adoption of environmental innovation.

Values are understood as ethical principles that an individual holds and which guide his/her behavior. Since the adoption of wood pellet heating is considered to be morally relevant due to its environmental friendliness, exploring the value orientations of adopters and non-adopters should provide insight into whether there are value differences between the groups or not. The concept of basic values, proposed by Inglehart [14], concerning materialism (high on traditional and survival values) vs. post-materialism (high on secular-rational and self-expression values) was adopted in this study. Moral thinking and environmental protection are more likely in a post-materialistic value set. NEP was used to measure environmental values.

3.3. Consumer behavior theory

Jackson's study regarding consumer behavior contributes to understanding consumer choice, i.e., how it is influenced, shaped and constrained [15]. Derived from consumer behavior theory, a decision strategy, a so-called meta-theory [16] represents the strategy employed by a household when

making decisions. This theory has been applied in diffusion simulation studies of green products [17–19]. There are four types of decision strategies: 1) Repetition: consumers habitually consume the product that has been consumed previously. This strategy applies when consumers are highly satisfied with the product they have in use and economic/technological uncertainty is relatively low. 2) Deliberation: consumers evaluate all possible alternatives and consume the product with the highest need satisfaction. This applies when consumers are dissatisfied with their current product, when it is difficult to consume a product, and when uncertainty is relatively low. 3) Imitation: consumers consume the product with the largest share among their peers. This situation applies when consumers are satisfied but the uncertainty is relatively high. Due to social network influences, a change occurring in the network will affect consumer behavior even though the consumer is relatively satisfied with the current product. 4) Social comparison: consumers compare the utilization of a product previously consumed and one with the largest market among their social networks, and select the product yielding the highest need satisfaction. This strategy applies when consumers are dissatisfied and find it difficult to consume a product while uncertainty is relatively high.

The respondents were asked to choose only one of the above-mentioned strategies that represented their strategies the best. The different decision strategies may influence adoption rate; for instance, when households deliberate, they are likely to find out about an innovation in its early stage. When individuals engage in social processing, they may learn about the innovation from others later in the diffusion process, whereas if they habitually repeat their behavior they may remain unaware of the innovation [16].

4. Results and discussion

Analyses of Variance (ANOVA) and Pearson's chi-square tests were used to determine the differences between the groups for interval and nominal data respectively. A non-parametric test, i.e. a Mann Whitney *U* test, was used for ordinal data. For the sake of clarity, the analysis was divided into 5 parts: 1) a socio-demographic profile, 2) basic and environmental values, 3) decision-related factors, 4) adopted and future choice heating systems, and 5) motivations, perceived barriers and subsidy required.

4.1. Socio-demographic profile

Previous studies on heating systems in Norway have used socio-economic factors such as age, income and education to characterize households [20–23]. In addition, this study also includes the household locations (districts) as a parameter since regional differences in climate and/or resource availability are expected to lead to the adoption of different heating systems. A Finnish study on heating systems demonstrated the significant influence of the spatial dimension, representing different lifestyles, when choosing a heating system [10]. In fact, wood pellet suppliers are not located in every district in Norway, and although wood pellets could technically be transported anywhere in the country, the transportation costs

could be substantial. Table 1 shows the differences between the adopter group and the non-adopter group with respect to their socio-demographic profile.

Table 1 shows that significant differences existed between the adopter group and the non-adopter group in terms of age. The adopter group was composed of relatively younger individuals as compared to the non-adopter group. As would be expected, younger individuals seem to be more open to a new technology, such as wood pellet heating. Rogers [7] argued that early adopters are typically younger in age. This result is also inline with evidence of a pellet diffusion study in Sweden conducted by Mahapatra and Gustavsson [9], which showed that older people find it more difficult to change their behavior as they have become habituated to their existing heating system.

The non-adopter group was dominated by those with a high-income level. Conversely, the adopter group was dominated by households with a medium-income level. Similar results were also found by Bjørnstad et al. [23], which confirmed that wood pellet heating commonly constituted an investment made by households with an income of less than NOK 300,000 in 2003. This result contradicted predictions made by the diffusion theory [7], as the adopter group was expected to have a higher income level than the non-adopter group. The result may reflect the fact that the high electricity price in 2003 compelled households with medium incomes to install wood pellet heating because they could afford the initial installation costs and also cared enough about the limited financial gains that can be obtained by the shift of heating system. The result could also reflect the fact that non-adopter groups mostly live in more urban areas which are often populated by individuals with higher education levels and incomes but with less possibility to shift to wood pellet heating.

Both samples were also statistically different with respect to education level. The non-adopter group had on average a higher education level than the adopter group. This finding again contradicted the diffusion theory, since the adopter group was expected to have an advanced education. On average, 27% of the Norwegian population has a university degree [24]. In both groups, more than 30% of respondents had a university degree. This confirmed that both groups were above the average Norwegian population with respect to their education level. The choice of house-owners as respondents in this study may have been the cause of this over-representation as compared to the educational levels in the Norwegian population in general.

With respect to district, the results showed that there was a significant difference between the adopter and the non-adopter groups. About 79% of adopters resided in eastern Norway. A plausible reason was that one of the biggest suppliers of wood pellets is located in the eastern part of the country, and that a close proximity to the wood pellet supplier provided households easy access to wood pellets. Another reason could be due to the effect of adopters' social network. Consequently, wood pellet heating would be a more profitable option in these districts. Bjørnstad et al. [23] supported these findings by confirming that wood pellet heating was mostly adopted by households residing in districts in the east (Hedmark, Oppland) and mid-Norway (Nord-Trøndelag). Meanwhile, the non-adopter group was distributed throughout all districts in Norway.

4.2. Values

Table 2 demonstrates that there were no statistical differences between the adopter and non-adopter groups with

Table 1 – Socio-demographic profile.

Parameters	Adopter		Non-adopter		Significance test
Continuous variable	N	Mean (S.D.)	N	Mean (S.D.)	
Age	662	49.9 (11.8)	269	53.5 (13.6)	ANOVA, $F(1,929) = 16.730, p < 0.001^{***}$
Categorical variable	N	%	N	%	
Income	660		280		$\chi^2 = 40.694; df = 7; p < 0.001^{***}$
Less than NOK 150,000	21	3.1	14	4.8	
NOK 150,001–NOK 250,000	96	14.3	20	6.9	
NOK 250,001–NOK 350,000	129	19.3	22	7.6	
NOK 350,001–NOK 450,000	134	20.0	44	15.1	
NOK 450,001–NOK 550,000	105	15.7	39	13.4	
NOK 550,001–NOK 650,000	68	10.2	42	14.4	
NOK 650,001–NOK 750,000	54	8.1	30	10.3	
More than NOK 750,000	53	7.9	69	23.7	
Education	660		280		$\chi^2 = 9.192; df = 2; p < 0.05^*$
Primary school	107	16.1	32	11.2	
High school	313	47.1	106	37.1	
University or higher	244	36.7	148	51.7	
District	665		289		$\chi^2 = 102.364; df = 4; p < 0.001^{***}$
East	526	79.1	95	32.9	
South	63	9.5	58	20.1	
West	24	3.6	76	26.3	
Mid-Norway	52	7.8	25	8.7	
North	0	0.0	35	12.1	

*** $p < 0.001$; ** $p < 0.01$; * $p < 0.05$; NOK = Norwegian kroner.

Table 2 – Basic and environmental values.

Parameters	Adopter		Non-adopter		Mann Whitney U test
	N	Mean (S.D.)	N	Mean (S.D.)	
Extent of materialism/post-materialism ^a	650	3.87 (0.59)	280	3.84 (0.57)	Z = -0.616, p = 0.538
New Environmental Paradigm ^a					
Balance of nature	663	4.18 (0.81)	284	4.14 (0.80)	Z = -0.967, p = 0.334
Limits of growth	657	4.02 (0.87)	283	3.98 (0.89)	Z = -0.519, p = 0.603
Human domination	661	2.41 (1.11)	282	2.37 (1.01)	Z = -0.706, p = 0.480
Perceived environmental heating system ^b					
Electric heating	591	3.21 (1.21)	268	3.65 (1.18)	Z = -5.022, p < 0.001***
Wood pellet heating	654	4.26 (0.87)	245	3.44 (0.83)	Z = -12.135, p < 0.001***
Heat pump	594	3.98 (0.76)	266	4.17 (0.95)	Z = -3.089, p < 0.01**

***p < 0.001; **p < 0.01; *p < 0.05.

a Score = 1 (fully disagree)–5 (fully agree); the higher the score, the higher the degree of environmental/post-materialism value.

b Score = 1 (not environmentally friendly at all)–5 (very environmentally friendly).

respect to materialism/post-materialism and environmental values. Both groups exhibited a trend toward post-materialism as should be expected for Norway, and expressed relatively high environmental values. These results were inline with the study of Bjørnstad et al. [23] of the households who had applied for the subsidy. These households exhibited almost the same level of environmental consciousness as the average Norwegian.

Interestingly, although neither group showed any significant differences with respect to pro-environmental values, the perception of what was an environmentally friendly heating system differed significantly. The adopter group believed that wood pellet heating was the most environmentally friendly, whereas the non-adopter group perceived a heat pump to be the most environmentally friendly heating system and that wood pellet heating was the least so. The result thus implied that providing credible information to the non-adopter group is crucial for wood pellet heating adoption since

the perception of it not being environmentally friendly may lead to the non-adoption of the system. A study devoted to the life cycle assessment of wood pellet heating for a household as compared to other alternatives, such as a heat pump and electric heating, would be valuable in order to provide scientific evidence of how environmentally friendly these heating systems are in Norway and under what circumstances.

4.3. Decision-related factors

Decisions can be made on several levels. Household decision-making differs from individual decision-making in the sense that a household often consists of several members who may have varying preferences, a fact that consequently influences choices. Table 3 shows that both groups agree that decisions regarding heating systems are mostly made by two adults in a household. The result is inline with a study of Lackman and Lanasa [25], indicating that many family purchasing decisions

Table 3 – Decision-maker, decision strategy, information search and sources.

Parameters	Adopter		Non-adopter		Pearson Chi ² test
	N	%	N	%	
Decision maker	666		290		Chi ² = 12.4232; df = 3; p < 0.01**
I	236	35.4	68	23.4	
My partner	7	1.1	7	2.3	
Both	410	61.6	189	65.2	
Other	13	2.0	26	9.0	
Decision strategy	658		281		Chi ² = 12.6233; df = 3; p < 0.01**
Repetition	75	11.4	66	23.5	
Deliberation	501	76.1	166	59.0	
Imitation	8	1.2	6	2.1	
Social comparison	74	11.2	43	15.3	
Proactive information search	652		285		Chi ² = 5.522; df = 1; p < 0.05*
Yes	183	28.1	54	18.9	
No	469	71.9	231	81.1	
Information sources	669		291		Chi ² = 4.1616; df = 3; p = 0.245
Government	253	37.8	97	33.3	
Family/Friends	244	36.5	90	30.9	
Other	273	40.8	98	33.7	
Vendor	83	12.4	27	9.3	

***p < 0.001; **p < 0.01; *p < 0.05.

Table 4 – The importance of the information source, recommendations and heating system attributes in the decision-making.

Parameters	Adopter		Non-adopter		Mann Whitney U test
	N	Mean (S.D.)	N	Mean (S.D.)	
Importance of information sources	669		291		
Government	253	3.09 (1.22)	97	3.27 (1.29)	Z = -0.165, p = 0.165
Family/Friends	244	3.27 (1.14)	90	3.49 (1.16)	Z = -1.829, p = 0.067
Vendor	273	3.61 (0.99)	98	3.32 (1.26)	Z = -1.805, p = 0.071
Other	83	3.18 (1.44)	27	3.30 (1.64)	Z = -0.480, p = 0.631
Importance of a recommendation from others in the decision-making	625	2.42 (1.21)	254	2.19 (1.18)	Z = -2.693, p < 0.001***
Importance of heating system attributes in the decision-making					
Functional reliability	620	4.65 (0.51)	261	4.52 (0.74)	Z = -1.831, p = 0.067
Indoor air quality	599	4.18 (0.80)	260	4.23 (0.87)	Z = -1.312, p = 0.189
Investment cost	600	3.91 (0.93)	255	4.00 (0.99)	Z = -1.648, p = 0.099
Operation cost	623	4.52 (0.64)	270	4.37 (0.85)	Z = -1.838, p = 0.066
Operation/maintenance work	608	4.27 (0.77)	262	4.29 (0.85)	Z = -0.858, p = 0.391
Fuel supply security	618	4.58 (0.68)	259	4.48 (0.84)	Z = -0.987, p = 0.324

***p < 0.001; **p < 0.01; *p < 0.05. Score = 1 (not important at all)–5 (very important).

were not the outcome of an individual choice but were often affected to a great extent by other family members. Moreover, this result supports the decision to use household-level decision-making as a unit of analysis for this study. However, there is a significant difference with respect to the decision-maker composition between the two groups. The number of one-person decisions made by the adopter group was higher than that of the non-adopter group. Nine percent of the non-adopter group indicated that the previous house-owner (categorized as Other) was the decision-maker, thus implying that certain respondents were using a heating system that had already been installed in the house.

Table 3 shows the statistical differences in the decision strategies employed by both groups. The adopter group employed more deliberation, less social comparison and less repetition than the non-adopter group. The repetition employed by the non-adopter group can explain the non-adoption of wood pellet heating, as they may have been unaware of the existence of such a system. The social

comparison strategy employed to a greater extent by the non-adopter group indicated their dissatisfaction with their existing heating system and the use of a social network as an information source.

The adopter group searched significantly more for information as opposed to their non-adopter group. However, information sources used by the two groups were not significantly different. Vendors and the government were the most important information sources used by both groups (see Table 3).

Although the two groups used the same information sources, these sources may influence a decision differently, depending on the relative importance of the information source. Table 4 demonstrates insignificant differences in the importance of the information source. Vendors and family/friends are the most important information sources for adopters and non-adopters, respectively. Adopters considered a recommendation to be more important than non-adopters for the decision (see Table 4).

The results show insignificant differences between the two groups regarding the importance of different heating system attributes. Both groups agreed that functional reliability was the most important factor to be considered, implying that the damage resulting from not having a functioning heating is

Table 5 – Communication.

Parameters	Adopter		Non-adopter		Pearson Chi ² test
	N	%	N	%	
Number of peers a heating system was recommended to					
0	68	10.1	115	39.5	Chi ² = 71.785; df = 5; p < 0.001***
1–5	302	45.1	121	41.6	
6–10	160	23.9	32	11.0	
11–15	51	7.6	7	2.4	
16–20	13	1.9	1	0.3	
More than 20	74	11.1	13	4.5	
Number of recommenders					
0	147	22.0	117	40.2	Chi ² = 30.962; df = 5; p < 0.001***
1–5	437	65.3	155	53.3	
6–10	61	9.1	15	5.2	
11–15	9	1.3	1	0.3	
16–20	2	0.3	2	0.7	
More than 20	13	1.9	1	0.3	

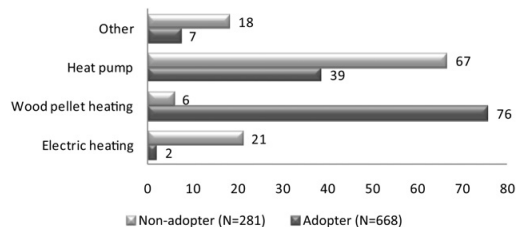

Fig. 2 – Percentages of respondents indicating the type of heating system they would recommend (Chi² = 898.976; df = 3; p < 0.001*). Some respondents indicated multiple choices.**

Table 6 – Social influence.

Social influence	Adopter		Non-adopter		ANOVA
	N	Mean (S.D.)	N	Mean (S.D.)	
Degree of influence from other people in deciding on a heating system (0%–100%)	661	26.7 (20.8)	289	30.2 (22.5)	F(1,948) = 5.7, p < 0.05*

a serious concern. It is also interesting to note that the order of importance of heating system attributes was the same for both groups.

The communication channel by which a household connects to other households affects the rate of adoption [7]. Table 5 exhibits statistical differences between both groups with respect to the number of peers a heating system was recommended to and the number of recommenders. The result shows that adopters had a higher number of recommending peers than the non-adopters. About 40% of non-adopters had no recommending peers. This might help explain the fact that the adopter group employed a deliberation strategy more than their non-adopter group because people who deliberate are likely to communicate more with others, thereby potentially showing opinion leadership. Adopters had more recommenders than non-adopters. The present study did not specifically define the identity of the recommenders, which meant they could be experts, vendors or other households. This evidence supports the previous result that because a recommendation was considered to be more important in decision-making, the adopter group gave and received recommendations more than the non-adopters. This is inline with Rogers' study [8] indicating that early adopters are more social and show opinion leadership, whereas late adopters are in contact with only few people (or none) and show very little to no opinion leadership.

Within the network of households, information is exchanged. It is hence interesting to discuss which heating system was recommended most by the two groups. Fig. 2 indicates that the recommended heating system was statistically different between the groups. Most adopters recommended wood pellet heating, whereas most non-adopters recommended heat pump.

It is worth noting that the second most recommended heating system by adopters was a heat pump (38.5%). One plausible explanation could be an expression of dissatisfaction with using wood pellet heating. Adopters who were dissatisfied were unlikely to recommend wood pellet heating; they would rather recommend another type of heating system. Other possible explanations could be that the households recommended more than one type of heating system, or that the limited ability to install a wood pellet stove in the household of the other person (e.g., no access to a chimney) was taken into account when a recommendation was given.

Social influence, which indicates the impact of social pressure on the decision, was also measured. Social influence was perceived higher in the non-adopter group than in the adopter group, i.e., there was a significant difference with respect to social influence (see Table 6). This result is consistent with previous results indicating that the non-adopter group employed more social comparison and used family/friends as the most important information sources. Such a result is also inline with Rogers' study [7] indicating that early adopters appeared to weigh their personal needs more than late adopters.

4.4. Adopted heating system

According to the diffusion of innovation theory, prior conditions, such as previous practices, affect a decision. Dissatisfaction with a previous heating system, for example, may drive a household to change. This section is intended to identify the reasons for such shifts by comparing previous and current heating systems for each group and the motivations behind the shifts. Anticipated preferences for future heating system are also compared.

Fig. 3 shows that electric heating was the dominant heating system for the non-adopter group, whereas a wood stove was the dominant system for the adopter group. Currently, electric heating still dominates in the households of the non-adopter group, while wood pellet heating is the new dominant heating system for the adopter group. The results also show a decrease in the use of wood stoves, fireplaces, electric heating, and a significant increase in wood pellet stoves for the adopter group. For the non-adopter group, only a small number of heating system changes was detected. The use of fireplaces decreased most, followed by wood stoves, while electric heating and heat pumps increased.

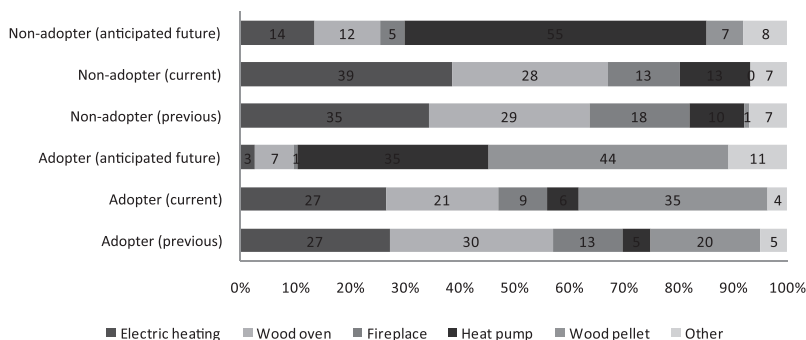

Fig. 3 – The composition of previous, current, and future choice of heating system.

Table 7 – Significance test.

Case	Chi ²	df	p-value
Previous: adopter vs. non-adopter	370.982	5	<0.001***
Current: adopter vs. non-adopter	345.553	5	<0.001***
Anticipated future: adopter vs. non-adopter	226.614	5	<0.001***
Adopter: previous vs. current	12.433	5	0.029*
Non-adopter: previous vs. current	4.530	5	0.476n.s.

***p < 0.001; **p < 0.01; *p < 0.05; n.s. = not significant.

The heat pump was the heating type most preferred by the non-adopter group, while wood pellet heating remained the most preferred heating for the adopter group, even though the adopter group said it would give more attention to the heat pump in the future. This finding calls for further research to investigate the relatively low future preference of wood pellet heating.

A significant difference with regard to heating system composition (previous vs. current) for the adopter group signifies that there have been significant shifts in heating systems (see Table 7). These shifts were likely away from a wood stove, fireplace or electric heating to wood pellet heating. For the non-adopter group, there was no such significant shift in heating systems. It is also noteworthy that the adopter group consisted of a considerable number of households that had adopted wood pellet heating early on, so it is interesting to see the differences between those who had adopted wood pellet heating some time ago and 'new' (previous–current) adopters. Additional analyses summarized in Table 8 shows that there were insignificant differences between previous and 'new' adopters of wood pellet heating with respect to income, education, and districts (adopter group) while there were significant differences between previous and 'new' adopters of heat pumps (non-adopter group) with respect to income and districts. The 'new' adopters of heat pumps (non-adopter group) were from low- and high-income households and resided mostly in eastern Norway.

Table 8 also indicates that there were significant differences between new adopters of wood pellet heating (adopter group) and new adopters of heat pumps (non-adopter group). The new adopters of wood pellet heating were those from low-

to medium-income households, with a high-school education and residing mostly in eastern Norway (82%), while the new adopters of heat pumps were those from high-income households with a university education and who lived mostly in eastern (35%) and western (35%) Norway.

Table 9 shows that there was a significant difference regarding the motivation for changing heating systems. It can be concluded that high fuel cost was one of the drivers of the shift to wood pellet heating. A previous study in Norway supported this by confirming that the households might have chosen another heating technology if energy prices had been higher at the point when the heating technology was chosen. Nevertheless, once installed, the households were not prone to changing the technology unless fuel prices changed considerably or if the heating system broke down [22]. For instance, high oil prices in 1986 were responsible for a significant reduction the use of liquid fuel for heating in Norway [20].

On the contrary, for the non-adopter group, a broken heating system was the most important motivation for changing heating systems. Since a majority of the non-adopter group would not change heating systems until the current stopped working, it was reasonable that there was no significant shift of heating systems. However, this group rated the motivation of "high fuel cost" almost as highly as did the adopter group.

4.5. Towards wood pellet heating

The aim of this section is to identify motivations (on the part of adopters), perceived barriers and subsidy required by non-adopters for shifting to wood pellet heating.

4.5.1. Motivation

Fig. 4 shows that the most highly rated motivation by the adopter group for installing wood pellet heating was that it was an environmentally friendly heating system. However, the combination of low operation costs and an increase in electricity prices seemed to be the most important explanation for shifting to wood pellet heating. This result was inline with previous evidence identifying high fuel costs as the most highly rated reason for the adopter group to change heating systems. In addition, Alakangas and Paju [26] revealed that the

Table 8 – Significance tests based on previous compared to current heating system.

Group	Adopter			Non-adopter		
	Previous (N = 351) vs. 'new' (N = 193) adopter of wood pellet heating			Previous (N = 60) vs. 'new' (N = 22) adopter of heat pump		
Significance test for with respects to	Chi ²	df	p-value	Chi ²	df	p-value
Income	2.747	7	0.907n.s.	32.722	7	<0.000***
Education	1.195	2	0.550n.s.	2.542	2	0.281n.s.
District	0.667	4	0.955n.s.	44.405	4	<0.000***
Significance test for with respects to	'New' adopters of wood pellet heating (N = 193) vs. 'New' adopters of heat pump (N = 22)					
Income	Chi ² = 57.155; df = 7; p < 0.001***					
Education	Chi ² = 13.250; df = 2; p < 0.001***					
District	Chi ² = 790.511; df = 4; p < 0.001***					

***p < 0.001; **p < 0.01; *p < 0.05; n.s. = not significant.

Table 9 – Motivations for shifting heating systems. Multiple answers allowed.

Motivations for shifting heating systems	Adopter (N = 625)		Non-adopter (N = 267)		Chi ² test
	n	%	n	%	
Broken	181	29.0	186	69.7	Chi ² = 24.88; df = 6; p < 0.001***
Too old	163	26.1	84	31.5	
High fuel cost	368	58.9	149	55.8	
High maintenance cost	99	15.8	42	15.7	
Moving	152	24.3	65	24.3	
House renovation	107	17.1	46	17.2	

increased use of wood pellets in Finland was mostly due to the sharp rise in oil price towards the end of the 1990s. A desire to use environment friendly heating systems and rising fuel prices are hence important factors in expanding the use of wood pellet heating.

Interestingly, only 8% of adopters indicated that the subsidy was the motive for installing wood pellet heating. The evaluation study of the heating system subsidy in Norway documented that a high proportion of households responded that they would even buy the heating system technology without a subsidy [23].

4.5.2. Perceived barriers

According to Wilson and Dowlatabadi [27], barriers to adoption should be positively identified rather than assumed to be the inverse of the drivers of adoption. For this reason, perceived barriers by the non-adopter group were assessed and are presented in Fig. 5.

Fig. 5 suggests that high installation costs were the leading barrier to the adoption of wood pellet heating. Economic constraints were the most important perceived barrier when it came to installing wood pellet heating. Bjørnstad et al. [23] documented that about 3671 applicants for subsidies were granted but that a mere 1215 of these grants were used. The reason for not installing the heating system, thus leaving the grants unused, was the high investment cost. This finding, however, appears to be at odds with the previous result which suggests that functional reliability was considered the most important reason when deciding on a heating system. One plausible explanation is that wood pellet heating is considered as a new emerging technology so that technological and/or economic uncertainties exist. For instance, households are more likely to undertake an investment cost if they are confident that a heating system is more reliable than others.

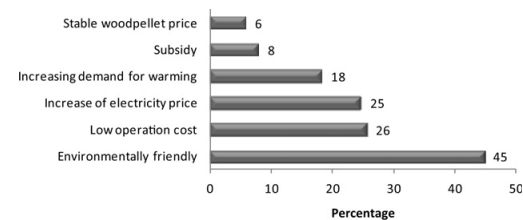

Fig. 4 – Motivations of adopters for using wood pellet heating (N = 602). Many respondents indicated multiple choices and the sum of the percentages consequently exceeds 100.

The technical barriers in terms of difficulties when it comes to refitting a house were ranked as the second most important barrier. Houses have to undergo some adjustments for operation, pellet handling and storage, and some houses are not easily retrofitted, for example if they do not have a chimney. Access to a chimney is of course another prerequisite for wood pellet heating that is lacking in some households. Other important technical barriers are work involved in handling the pellets and lack of after-sales service of pellet stoves. For certain households, such as those consisting of older people, the work required when using a wood pellet stove is difficult because of the physical demands. Moreover, homeowners who value their time prefer heating systems that require less or no work. Automation could be a possible area for development, while the lack of after-sales service has already been seen as a problem for wood pellet development in Finland [26].

A barrier in terms of a lack of information and recommendations, hence leading to low market shares, cannot be ignored. Developing more effective communication strategies, e.g., communicating information and shaping opinions, can be seen as a promising way to drive up wood pellet adoption.

It is worth noting that the operational cost was perceived as a barrier by the non-adopter group, while the adopter group perceived the same factor as a motive. This can potentially be explained by the fact that the adopter group mostly resided near wood pellet suppliers, whereas a large part of the non-adopter group lacked easy access to wood pellets. This fact is also reflected in the response that showed that fuel security



Fig. 5 – Perceived barriers of non-adopters to installing wood pellet heating (N = 264). Many respondents indicated multiple choices, so the sum of the percentages exceeds 100.

issue were the fourth biggest barrier as perceived by the non-adopter group.

4.5.3. Subsidy required

As high installation costs were the most commonly perceived barrier for the non-adopter group, a further analysis of the subsidy required to defray costs is essential. In fact, the current subsidy provided by the Norwegian government, which covers as much as 20% of the installation costs, has not resulted in the expected increase in the adoption of wood pellet heating. We attempted to acquire information about the level of financial support that would be requested by non-adopters in order for them to change to wood pellet heating. The results show that the mean required subsidy was about 64% of the installation cost (see Fig. 6), which is a number that far exceeds the existing (and legally possible) subsidy. One plausible explanation for the reluctance on the part of homeowners could be the economic uncertainty of such an investment. Only 1 out of 5 found it to be profitable [23]. This is due to the small difference between electricity and pellet prices. The distribution also shows that many participants chose psychologically appealing numbers such as 50% or 100% for the subsidy amount. This seems to indicate that subsidies seem not only to work on an economic level but also on a psychological level. Interestingly, 6.2% of non-adopters required a subsidy that was lower or of an equal amount to the maximum subsidy presently provided by the government. This specific group perceived the biggest barrier to installing wood pellet heating (despite their expressed willingness to adopt wood pellet heating with the current subsidy) was the difficulty of refitting the house for wood pellet heating, followed by a lack of information and the work requirement for wood pellet heating.

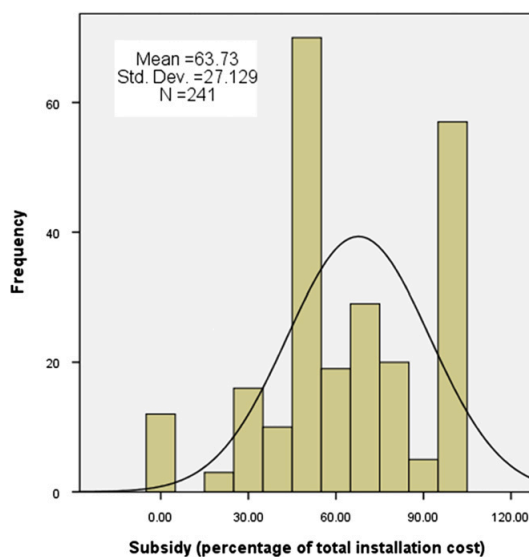

Fig. 6 – The distribution of required subsidy by non-adopters for wood pellet heating.

5. Conclusions

The present study provides interesting insights regarding adopters and non-adopters of wood pellet heating in Norwegian households by investigating the differences between the two groups for several factors that are commonly recognized as the key points in adoption studies. The results point to significant differences between the adopter and the non-adopter groups with respect to age, income, education, location, perceived environmental friendliness of the heating system, decision maker, decision strategy, proactive information search, importance of recommendations, number of peers a heating system was recommended to, the number of recommenders, recommended heating systems, social influence in the decision, previous and current adopted heating systems, anticipated future heating systems as well as reasons for changing heating systems. There were insignificant differences between the two groups with respect to values, information sources used, perceived importance of information sources and the importance of heating system attributes in the decision-making.

With respect to some attributes, the adopter group demonstrated characteristics of early adopters; on the other hand, the non-adopter group displayed characteristics of late adopters, according to diffusion and innovation theory [7]. However, the adopter group had lower income and education levels as compared to their non-adopter group, which contradicted the theory.

Both groups shared the same level of environmental values. However, the perception of which heating system was the most environmentally friendly differed significantly. Further studies on an environmental assessment of heating systems would be valuable in order to reduce this distortion.

The findings also showed that the adopter group made significant shifts in heating systems. The shifts were away from wood stoves, fireplaces, and electric heating to wood pellet heating. High fuel costs were the main motivation for the shift. On the other hand, there was no significant shift for the non-adopter group, for whom electric heating remains the dominant heating system. Fireplaces and wood stoves decreased, while electric and heat pump use increased.

A desire for an environmentally friendly heating system, low operation costs and an increase in electricity prices were identified as the top three motivations by adopters for installing wood pellet heating. Meanwhile, the perceived barriers against changing to wood pellet heating included economic, technical and information barriers. The economic barrier was the most important. Moreover, it was found that the mean value of the subsidy required by the non-adopter group was 64% of the total installation cost. About 6% of the non-adopter group exhibited a willingness to install wood pellet heating based on the existing subsidy. This group, however, identified difficulties refitting the house, a lack of information about wood pellet heating and the anticipated required work connected to wood pellet heating as remaining barriers that prevent them from actually installing a wood pellet stove.

For policy makers, this study should provide an understanding of the reasons behind adoption vs. non-adoption. Appropriate measures and incentives can be better designed

to encourage the adoption of wood pellet heating. In addition to financial and technical problems, a lack of information could be interpreted as an important barrier for wood pellet heating. Further, the subsidy requested by non-adopters should enable policy makers to estimate the financial support needed for building the wood pellet market.

Acknowledgment

Financial support for this study has been provided by the Norwegian University of Science and Technology (NTNU), Norway, and is gratefully acknowledged. A special thanks to Geir Skjevrvak, who assisted with technical aspects of the study.

REFERENCES

- [1] Innstilling til Stortinget fra energi- og miljøkomiteen, vol. 133; 2002–2003, <http://www.stortinget.no/Global/pdf/Innstillinger/Stortinget/2002-2003/inns-200203-133.pdf>; 2002–2003 [last retrieved in September 2009].
- [2] Statistics Norway, 2006, [last retrieved in January 2008], <http://www.ssb.no/emner/01/03/10/husenergi/>.
- [3] Trømborg E, Bolkesjø TF, Solberg B. Biomass market and trade in Norway: status and future prospects. *Biomass Bioenergy* 2008;32:660–71.
- [4] Vogel S. Environmental attitudes and behavior in the agricultural sector empirically determined by use of an attitude model. *Diskussionpapier* 1994;32-W-94 [last retrieved in June 2008], http://www.boku.ac.at/wpr/papers/d_papers/dp_cont.html.
- [5] Lalonde R, Jackson EL. The new environmental paradigm scale: has it outlived its usefulness? *J Environ Educ* 2002; 33(4):28–36.
- [6] Dunlap RE, Van Liere KD. The “New Environmental Paradigm”: a proposed measuring instrument and preliminary results. *J Environ Educ* 1978;9(4):10–9.
- [7] Rogers EM. *Diffusion of innovations*. 4th ed. New York: Free Press; 2003.
- [8] Jager W. Stimulating the diffusion of photovoltaic systems: a behavioral perspective. *Energy Policy* 2006;34:1935–43.
- [9] Mahapatra K, Gustavsson L. Innovative approaches to domestic heating: homeowners' perceptions and factors influencing their choice of heating system. *Int J Consum Stud* 2008;32(1):75–87 (13).
- [10] Kasanen P, Lakshmanan TR. Residential heating choices of Finnish household. *Econ Geogr* 1989;65(2):130–45.
- [11] Tapaninen A, Seppänen M, Mäkinen S. Characteristics of innovation: a customer-centric view of barriers to the adoption of a renewable energy system. *Int J Agile Systems Manag* 2009;4(1/2):98–113.
- [12] Clark CF, Kotchen MJ, Moore MR. Internal and external influences on pro-environmental behaviour: participation in a green electricity program. *J Environ Psychol* 2003;23: 237–46.
- [13] Stern PC, Dietz T, Abel T, Guagnano GA, Kalof L. A value-belief-norm theory of support for social movements: the case of environmentalism. *Hum Ecol Rev* 1999;6(2):81–96.
- [14] Inglehart R. The silent revolution in post-industrial societies. *Am Political Sci Rev* 1971;65:991–1017.
- [15] Jackson T. Motivating sustainable consumption: a review of evidence on consumer behavior and behavioral change. In: A report to sustainable development research network, Centre for environmental, University of Surrey, http://www.sd-research.org.uk/wp-content/uploads/motivatingcfinal_000.pdf; 2005 [last retrieved in November 2009].
- [16] Jager W. Modeling consumer behavior, Doctoral thesis, Rijksuniversiteit Groningen, the Netherlands; 2000.
- [17] Janssen MA, Jager W. Stimulating diffusion of green products: co-evolution between firms and consumers. *J Evol Econ* 2002;12:283–306.
- [18] Schwoon M. Simulating the adoption of fuel cell vehicles. *J Evol Econ* 2006;16(4):435–72.
- [19] Schwarz N, Ernst A. Agent-based modeling of the diffusion of environmental innovations – An empirical approach. *Technol Forecast Soc Change* 2009;76:497–511.
- [20] Brottemsmo J. Working Paper. Residential heating choice and energy demand: Norwegian responses in 1980 and 1990, vol. 118/1993. Center of Research in Economics and Business Administration; 1994.
- [21] Nesbakken R, Strøm S. The choice of space heating system and energy consumption in Norwegian households. *Statistics Norway*; 1994.
- [22] Nesbakken R. Residential energy consumption for space heating in Norwegian households: a discrete-continuous choice approach, Discussion Papers vol. 231, Research Department, Statistics Norway; 1998.
- [23] Bjørnstad E, Grande J, Sand R, Wendelborg C. Evaluering av tilskuddordninger til varmpumper, pelletskaminer og styringssystemer. Nord Trøndelags-forskning, http://generator.firmanett.no/t/forforsk/doc/Ra_2_05.pdf; 2005 [last retrieved in September 2009].
- [24] Statistics Norway; 2008, [last retrieved in January 2009], <http://www.ssb.no/emner/04/01/utniv/tab-2009-08-25-01.html>.
- [25] Lackman C, Lanasa JM. Family decision-making theory: an overview and assessment. *Psychol Mark* 1993;10(2):81.
- [26] Alakangas E, Paju P. Wood pellets in Finland- technology, economy and market. OPET report 5, VTT processes, Jyväskylä, www.tekes.fi/opet/pdf/OPET_report5_june2002.pdf; 2002 [last retrieved in October 2007].
- [27] Wilson C, Dowlatabadi H. Models of decision making and residential energy use. *Annu Rev Environ Resour* 2007;32: 169–203.

Psychological Factors in the Diffusion of Sustainable Technology: A Study of Norwegian Households' Adoption of Wood Pellet Heating

Bertha Maya Sopha

*Industrial Ecology Programme and Department of Energy and Process Engineering
Norwegian University of Science and Technology
N-7491 Trondheim, Norway*

Christian A. Klöckner

*Department of Psychology, Section for Risk Psychology, Environment and Safety
(RIPENSA)
Norwegian University of Science and Technology
N-7491 Trondheim, Norway*

Submitted for publication 2010

Psychological Factors in the Diffusion of Sustainable Technology: A Study of Norwegian Households' Adoption of Wood Pellet Heating

Bertha Maya Sopha¹, Christian A. Klöckner²

¹Industrial Ecology Programme and Department of Energy and Process Engineering, Norwegian University of Science and Technology, NO-7491 Trondheim, Norway

²Department of Psychology, Section for Risk Psychology, Environment and Safety (RIPENSA), Norwegian University of Science and Technology, NO-7491 Trondheim, Norway

Abstract

This paper aims to understand the determinants of the adoption of wood pellet technology for home heating to identify possible strategies against the slow diffusion of wood pellet in Norway. A mail survey of 737 Norwegian households was conducted in 2008, involving wood pellet adopters and non-wood pellet adopters as respondents. An integrated model combining psychological factors (such as intentions, attitudes, perceived behavioral control, habits and norms), perceived wood pellet heating characteristics, and ecological and basic values is applied to predict the installation of a wood pellet stove retrospectively. Results from a path analysis gain empirical support for the proposed integrated model. Wood pellet heating adoption is mainly predicted by a deliberate decision process starting with the evaluation of heating system characteristics, mediated by attitudes and intentions. A lack of perceived behavioral control and behavioral lock-in pose relevant barriers to the adoption process. The influence of norms and values are indirect and only minor in the given market conditions. Therefore, focusing on values or norms should not be of highest priority at the moment, whereas improvement of the subjective evaluation of the functional reliability and the costs related to wood pellet heating should have first priority. The small but significant influence of habitual decision making indicates that presenting alternatives and increase decisional involvement could be other promising strategies to reduce cognitive lock-in in decision-making.

Keywords: *wood pellet heating, Norwegian households, psychological model, values, technology characteristics, path analysis*

1. Introduction

Successful diffusion of new technology requires more than just a good new product and a marketing strategy. Consumers' decision making is an important part of this process and deeper understanding of determinants of such a decision lacks often. The aim of the present study is to provide a more holistic understanding of mechanisms in the adoption of wood pellet heating in Norway. Heating in the residential sector is an important area to target with respect to energy use. Whereas air conditioning is a main driver of energy use in regions of the world with warm climate, home heating is a significant contributor to energy consumption in regions with rather cold climate. In Norwegian households for example home heating constitutes the largest share of energy consumption in the private sector and accounts for approximately 50% of an average household's energy use [1,2].

Due to the public investment in hydropower between 1960 and 1990 and low electricity prices in the subsequent years the dominant residential heating system in Norway nowadays is electric heating. It might be argued, that with respect to CO₂-emissions the use of electricity for heating is unproblematic if the source is hydropower, but the strong focus on electricity as the primary source for heating has recently lead to problematic situations in Norway: Electricity supplied from hydropower is significantly affected by precipitation. When there is low precipitation, for instance in the winter of 2002-2003, so that energy production cannot meet the demand, Norway becomes a net importer of energy. While the Norwegian production of electricity is almost 100% regenerative, the imported energy is generated from various sources including nuclear power and fossil fuel. This is especially problematic when periods of low precipitation overlap with periods of high demand – such as in the unusually cold and dry winter during the first three months of 2010. Electricity prices peaked (the development of electricity prices can be checked at <http://www.nordpoolspot.com/>) and the demand for alternative heating sources such as ordinary wood stoves increased significantly.

According to Jamasb and Pollitt [3], diversification is the most common suggestion in order to reduce overdependence on particular types of energy supply. However, with respect to climate change this diversification should occur with the least possible impact on CO₂ emissions. Therefore, a combination of different approaches seems to be useful: (a) extending and diversifying the production of sustainable electricity, for example by implementing new

hydropower plants, raising efficiency in existing plants, and extending the use of other sources of electricity (wind turbines, wave or tidal power plants, etc.); (b) increasing energy efficiency on the user side and reducing energy demand; (c) implementing heating sources which utilize available alternative sources of energy. Norwegian government has thus supported alternative heating systems for households to reduce electricity consumption and to diversify the heating supply for domestic households. This paper focuses only on the last of the three strategies: implementing alternative heating technologies into the Norwegian market. Despite market interventions, the diffusion of wood pellet heating has however been rather slow in comparison to other new heating technologies like air-to-air-heat pumps. It was reported that only 3 out of 1000 households had pellet stoves installed in 2006 [4].

Although studies of wood pellet heating are very limited, some studies have already investigated reasons of the slow diffusion of wood pellet heating in different countries, i.e. Sweden, Finland, Austria, Denmark and Norway [5-10]. Those studies shared common insights in the sense they identified various factors contributing to the slow diffusion of wood pellets, such as fuel price, high investment cost, lack of technology and service, etc. None has been done however in terms of decision process.

In other behavioral domains like transportation, recycling, water conservation, eco-labeled products, and fuel choice, the study of choice processes has however, been successfully applied to promote more sustainable behavior alternatives (e.g. Johns et al. [11]). A comprehensive study of choice processes with respect to a residential heating system is, however, still lacking.

The present study, therefore, attempts to reveal psychological factors underlying the adoption of wood pellet heating in Norwegian households. It is, therefore, necessary to identify relevant barriers to or determinants of behavioral change in order to achieve changes in the desired way. The present study is not to research the optimal balance of heating systems in Norway, i.e. the authors do not claim that an extremely high adoption rate of wood pellet heating is desirable both from an environmental and economical perspective. The aim is to understand factors contributing to the underutilization of a specific system in a market where diversification would be beneficial. The substantial bio-energy resources available in the form of residues from the Norwegian wood industry makes wood pellet heating especially

interesting for the Norwegian market. The basic mechanisms, however, also apply to other underutilized heating systems and the situation in other countries.

2. Theoretical Background

Consumer choices have been extensively studied in economic, psychological and sociological research. In the area of residential decision making on energy use, Wilson and Dowlatabadi [12] reviewed theoretical models from four research fields: (a) conventional and behavioral economics, (b) technology adoption theory and attitude-based decision making, (c) social and environmental psychology, and (d) sociology. Also Nyrud et al. [13] analyzed the perception of bio-energy heating in Norway and used a model that included both psychological and system related factors. A similar interdisciplinary approach is followed in this section which outlines relevant theories related to energy related decision making. Three different perspectives are taken to explain adoption of alternative heating systems, one approach analyzing technology characteristics as the main driver, one analyzing psychological variables behind environmental behavior, and one analyzing values as predictors of pro-environmental choices. In the last part of this section an integrated model is proposed that will be tested on data of a Norwegian household sample.

2.1. Technology Characteristics Predicting Adoption

Rogers' Diffusion of Innovation framework [14] which is based on more than 1500 individual studies emphasized that the speed with which individuals pass through the innovation-decision process is partially dependent upon their perception of an innovation's characteristics. Rogers described five such characteristics: (a) relative advantage compared to conventional products, (b) compatibility with existing values, past experiences and needs of potential adopters, (c) complexity of the system, (d) trialability of the new product, and e) observability of the innovation in the market. Perceived innovation characteristics determined the adoption and rejection of information technology applications in many studies (e.g. Jeyaraj et al. [15]). Rogers' framework also applies to environmental innovations such as environmental heating systems. Tapaninen et al. [16] were able to show that perceived technology characteristics

influenced customers' adoption of wood pellet heating in Finland. In addition, Kasanen and Lakshmanan [17] identified costs in terms of annual cost and investment cost as important in adopting a heating system. Another study on the diffusion of wood pellet heating in Sweden [5] recognized that annual heating cost, functional reliability, investment cost and perceived indoor air quality were the most important factors when choosing a heating system. Nyrud et al. [13] found that characteristics of the heating system such as perceived comfort, perceived efficiency, and reliability were the most important predictor of satisfaction with a new wood stove.

Based on former studies regarding heating system choice [5,17], the present study operationalized the specific wood pellet heating characteristics as follows: total cost (investment and operation cost), functional reliability, maintenance/operation work, indoor air quality and fuel supply security in term of price stability. Some of the characteristics proposed by Rogers [14] are discussed in the following sections (past experience, values).

2.2. A Psychological Approach – The Comprehensive Action Determination Model (CADM)

Psychology has provided a large body of research on why people make choices based on a number of factors including norms, attitudes, intentions, habits, and the perceived ability to act. Several models have been suggested to explain psychological processes preceding behavior (e.g. [18-20]). Nyrud et al. [13] used factors described in the theory of planned behavior [18] to predict people's inclination to continue using wood stove heating. Due to the explorative nature of the present study, the Comprehensive Action Determination Model (CADM) proposed by Klöckner and Blöbaum [21] was selected as the basis for the present study as this model offers its holistic approach to account for a large variety of predictors of behavior. It combines basic assumptions of the theory of planned behavior [18], the norm-activation theory [19], the ipsative theory of behavior [20], findings about the influence of routines and habits on environmental behavior [22] and previous attempts to integrate the respective theories [23,24]. The following paragraph gives a short summary of the basic assumptions of the model (for a discussion of the theoretical background of the model consider the original paper).

The CADM proposes three direct predictors of behavior: intentions, habits, and perceived behavioral control. Intentions capture the deliberate part of the decision making

progress. An intention is the person's feeling of being ready and wanting to perform a behavior – in our example buying a wood pellet stove. Perceived behavioral control captures a person's evaluation of his/her ability to perform an intended action. Both factors are described in the theory of planned behavior [18]. Habits capture the influence of behavioral routines and automaticity on behavior. Habits are an important predictor of everyday behavior, their influence on singular decisions such as installing a heating system should be virtually irrelevant. However, as habitual decision making is characterized among other things by simplified decision rules a strategy of not searching for information but just relying on the already known heating system when a decision is due can be considered “habitual” on a very abstract level. Furthermore, a more general perspective might be taken by considering behavior “habitual” if some form of cognitive lock-in can be detected. Johnson et al. [25] demonstrated that familiarity with one online shop – created by learning how to use it in the past – reduces the probability of trying an alternative. This creates loyalty and a lock-in phenomenon that excludes possible competitors. A similar phenomenon has been demonstrated by Gärling et al. [26] in an experimental study of a fictitious energy market. It is though reasonable to assume that also familiarity with one type of heating system (most likely electric heating) may create a cognitive lock-in situation and loyalty towards the established heating system. This phenomenon might act in a comparable way to habits in everyday behavior by reducing the search for and use of information about alternatives [27].

On the second level of the model, intentions are predicted by the person's attitudes towards the behavior, perceived behavioral control, social norms, and personal norms. A similar set of predictors was also described by Bamberg and Möser [23] for other types of pro-environmental behavior. Attitudes – which are the general evaluation of activated beliefs about the behavior and its alternatives – summarize if a person perceives a certain behavior to be positive. Perceived behavioral control does not only influence behavior but also intentions because people might anticipate their limited ability to perform a behavior already before they form an intention. Social norms capture the influence of relevant other people on a decision or, briefly put, the social pressure. While forming an intention, people also anticipate what other people expect them to do, if those people's opinion is relevant for them in this situation, and how much it would psychologically cost them to act against those expectations. Finally, the CADM proposes that intentions are influenced by personal norms, which are feelings of moral

obligation to act according to the personal value system. Especially in situations which are morally relevant (like helping other people, decisions which have an impact on following generations, etc.) the influence of personal norms on intentions should be relevant which has been demonstrated by Bamberg and Möser [23]. Those personal norms should over time influence also attitudes, because they act as a moral reference system in the background of decision making that single beliefs might be checked against. Personal norms should be related to social norms as a personal value system is acquired during socialization by interacting with expectations of relevant other people.

The different components of the model are supposed to vary in importance over time, between behavioral domains and between cultures. The CADM has already been successfully applied to explain travel mode choice [21,28] and recycling behavior [29]. The CADM and its theoretical background are discussed in more detail in Klöckner and Blöbaum [21] and Klöckner [30].

2.3. Values and Adoption Behavior

As already discussed in the introduction, heating system choice has also an environmental dimension which makes the decision at least partly an environmental decision. Hardin [31] acknowledged that environmental decisions were not only related to questions of technical solutions but also to moral responsibility. As environmental behavior is considered a moral issue, values as the most basic psychological representation of moral implications are explored further in the present study as a possible predictor of heating system choice. Many studies have shown that value orientations are relevant determinants of environmental behavior. A study by Clark et al. [32] indicated for example that the bio-altruistic and pro-social values were significant factors in predicting participation in taking part in a green electricity scheme. Poortinga et al. [33] demonstrated the importance of values and worldviews for the support of environmental policy measures and energy saving behavior.

Values are understood as ethical principles that an individual holds and which guide his/her behavior. Values are stable over time and therefore have the power to impact behavior on a very general level. The structure of value systems has been extensively studied in large world-wide studies and one of the most recognized value categorizations traces back to Inglehart [34,35]. Inglehart proposes a two-dimensional structure of the most basic values

(survival vs. self-expression values and traditional vs. secular-rational values) which can be further collapsed into one value dimension: materialism (high on traditional and survival values) vs. post-materialism (high on secular-rational and self-expression values). Moral thinking and environmental protection are more likely in a post-materialistic value set. Another tradition of value research is based on the extensive work by Schwartz [19]. He structured values empirically into ten dimensions which are grouped by similarity into a two-dimensional system. The ten value types can be grouped into higher order dimensions. One of them – self-transcendence which incorporates benevolence and universalism – has been shown to be a good predictor of pro-environmental behavior [36]. More domain specific value systems have been developed with respect to environmental actions: Dunlap and van Liere [37] introduced an environmental value scale known as the “New Environmental Paradigm”, sometimes referred to as a worldview [33]. Initially, the scale was supposed to be uni-dimensional, however between two and four sub-dimensions have been identified by other researchers. A common labeling of the sub-dimensions is “balance of nature”, “human domination” and “limits to growth” [38]. The scale has since its publication gained worldwide attention and correlations with environmental behavior have been documented (see [39] for a review of 30 years of NEP-scale use).

Although the CADM already includes personal norms as proximal stand-in for values, the relation to more general value orientations is still unclear. The Value-Belief-Norm Theory (VBN) developed by Stern et al. [40] attempts to explain how value structures of different generality affect environmental behavior. Stern et al. [40] proposed a value cascade starting with the most general basic value orientation (materialism vs. post-materialism), then taking the intermediate steps of domain specific ecological values (NEP) and personal norms to behavior. In the present study the cascade idea was adopted and basic values were operationalized as the degree of post-materialism in line with Inglehart and Abrahamson [35]. Three subscales of the New Ecological Paradigm were used as operationalization of domain specific values. Self-transcendence can be considered on a comparative level as materialism and was not included in the study.

2.4. An Integrated Approach to Explain Wood Pellet Adoption

The integrated model proposed in the present study combines psychological factors (CADM), perceived wood pellet heating characteristics, and basic and ecological values in (retrospectively) predicting the installation of a wood pellet stove. The model is displayed in Figure 1. The heating system characteristics and both basic and domain specific values are not supposed to predict the choice directly but mediated by the CADM structure. Values should have an impact on behavior that is mediated by personal norms as proposed in the VBN [40]. The perceived heating system characteristics should influence both attitudes (as they become part of the behavioral belief system) and perceived behavioral control (as they might enhance or reduce the perceived ability to implement a heating technology). The hypotheses derived from the integrated model are as follows,

1. The adoption of wood pellet heating is directly predicted by three determinants: intentions, habits and perceived behavioral control. The influence of habit is however hypothesized to be relatively small and only on the level of extremely simplified decision strategies understood as a cognitive lock-in because the decision on a heating system is not considered as an everyday decision. Intentions should therefore have a strong influence on the behavior. The influence of social and personal norms is indirect and mediated by intentions.
2. Perceived wood pellet heating characteristics influence the choice indirectly, mediated by psychological variables. It is hypothesized that these perceived wood pellet heating characteristics influence the households' evaluation of wood pellet heating (attitudes). Perceived wood pellet heating characteristics could furthermore act as situational constraints that could limit a household's perceived ability to install a certain type of heating system (perceived behavioral control).
3. It is expected that personal norms mediate the relationship between values and intention. Furthermore, personal norms should also be influenced by social norms (pressure from relevant other people).

3. Method

A quantitative survey was chosen as the method for assessing different proposed components in households' decision making regarding wood pellet heating adoption. The final model was tested against the empirical data with a path analysis without any data driven modifications.¹ The model was not tested as a structural equation model (SEM) with latent variables because most constructs were only measured with one or two indicators which poses a potential threat to an SEM analysis due to under-determination of the latent constructs [41]. The statistical package MPLUS [42] was used for the analysis to deal with the dichotomous nature of the dependent variable and non-normal distributions of single variables (the robust mean and variance adjusted weighted least square estimator [WLSMV] was used). Full information maximum likelihood estimation was applied to deal with missing values. Missing values on exogenous variables resulted in a reduction of the sample size (see below).

3.1. Sample²

The present study was conducted by using a mail survey involving 737 Norwegian households. The original sample of 3000 households was constructed of 50% wood pellet users and 50% non-wood pellet users to have a large enough proportion of people that made the decision to install a wood pellet stove already. Hence, the sample of the present study is not representative for the Norwegian population because of the overrepresentation of wood pellet users. The wood pellet group represented almost the complete population of wood pellet adopters in Norway. The non-wood pellet group was drawn as a random sample from the population register. Only house owners were chosen as respondents because they had the authority to make decisions about heating systems independent of other parties. The unit of analysis in our study is the household because a decision regarding a heating system is usually made on household level. One member of the household was asked to answer the paper-pencil questionnaire and the household members were left to decide who is most qualified.

The questionnaires were sent by mail in autumn 2008. After three weeks, the response rates in the wood pellet and non-wood pellet group were 34.6% (519 questionnaires) and 10.3% (154 questionnaires) respectively. A reminding letter containing another copy of the questionnaires was mailed after three weeks. 150 additional responses from the wood pellet group and 137 from the non-wood pellet group were received after the reminder. This resulted

in a response rate of 44.6% (669 responses) for the wood pellet group and 19.4% (291 responses) for non-wood pellet group. Several respondents did not answer the entire questionnaire, and therefore the response rate varies for each question. Participants with missing values in exogenous variables had to be excluded from the study so that the final analysis is based on a sample of 737 participants (542 wood pellet users and 195 non-wood pellet users).

A χ^2 test was conducted to test if the distribution of the 1500 non-wood pellet households in the random sample deviated significantly from the regional distribution of all households in the 19 administrative regions in Norway without a significant result ($\chi^2=17.633$; $df=18$; $p=0.480$). In other words, the composition of the original sample of non-wood pellet users was representative for the Norwegian population by region. Even though it is not the case for the wood pellet users ($\chi^2=488.028$; $df=13$; $p<0.001$), the sample for wood pellet users is representative for the Norwegian wood pellet users as it accounts for roughly 80% of all wood pellet users in Norway.

To test possible self-selection effects, a χ^2 test was also performed for both groups to compare the original and the response sample by region. The tests revealed that there was no statistical difference between the original samples and response samples for wood pellet users ($\chi^2=2.031$; $df=13$; $p=1.000$) and non-wood pellet users ($\chi^2=8.689$; $df=18$; $p=0.967$). Thus, a self selection bias could not be found with respect to regional distributions. Other data on the original population to test self-selection bias in the response samples was not available. It might, therefore, be possible that self-selection processes resulted in an undetected bias, especially as the response rate in the two groups was different.

3.2. Measures

The dependent behavioral variable “choice of a wood pellet heating system” was operationalized using membership in one of the two groups in the sample, coded 1 as wood pellet and 0 as no wood pellet use. The group membership therefore represents a real choice of wood pellet heating adoption; the decisional process however is only retrospectively analyzed and the point in time when the households made the decision is unknown and most likely varying. Personal norm (PN), attitudes (ATT), perceived behavioral control (PBC), and intention (INT) were measured with two items each adopted from the work of Klöckner and

Blöbaum [21] modified with respect to heating system choice and then translated to Norwegian. Habit (HAB) was in the present study operationalized as utilizing a strategy of repeating the decision for the previous heating system by asking the participants whether they implement a choice strategy to just rely on their old heating system without consideration of alternatives, coded as 1, or not, coded as 0. This can be considered a behavioral or cognitive lock-in. It has to be noted that the operationalization of habits in the present study is therefore not comparable to the measurement of habits discussed in the paper by Klöckner and Blöbaum [21]. Social norms (SN) were measured as the estimated degree of other people's influences when the household was making a decision (0%, 20%, 40%, 60%, 80%, and 100%). This is again a measure that deviates from previous measures of social norms. Indicators of functional reliability (FR), required work (WORK), indoor air quality (IAQ), total cost (COSTS) and fuel supply security (SSEC) were adapted from Moore and Benbasat [43], modified according to the needs of the present study and then translated to Norwegian. The items used can be found in Appendix A. The answering scales in the present study were used in accordance with the original studies the items were derived from: A 7-point Likert scale from "totally disagree" coded as 1 to "totally agree" coded as 7 was used on all items except the habits and the social norms item. The extent of materialistic or post-materialistic value orientation (PMAT) was measured using 6 indicators on a 5-point Likert scale and adapted from Vogel [44]. The higher the score is the higher is the degree of post-materialism. The New Environmental Paradigm (NEP) scales were adopted from Lalonde and Jackson [45] who based their scale on the original work by Dunlap and van Liere [37]. Each NEP subscale (balance of nature: NEP_{BON}; limits to growth: NEP_{LTG}; and human domination: NEP_{HD}) was measured by two items. For the path analysis sum scores of multi-item constructs were calculated. Table 1 displays the basic statistics of the variables in the path analysis and internal consistencies of the scales (Cronbach's alpha). Most scales have an acceptable to very good internal consistency; the indoor air quality scale, however, has limited internal consistency. Due to the confirmatory nature of the study, no regrouping of items was conducted before the path analysis was applied. Appendix B displays the correlation of all variables used in the path analysis. It has to be noted that some correlations are very high (especially between INT, ATT and PBC) which might indicate a problem with discriminant validity of the measures. Results of a factor analysis conducted during construction of the scales point into the same direction indicating

that the indicators of INT, ATT and PBC load all high on the same factor. As the operationalizations of the three variables were chosen in line with standard procedures we decided not to collapse the scales into one and to keep them as they are. A high correlation between these variables that are theoretically supposed to have a strong relation might also be meaningful.

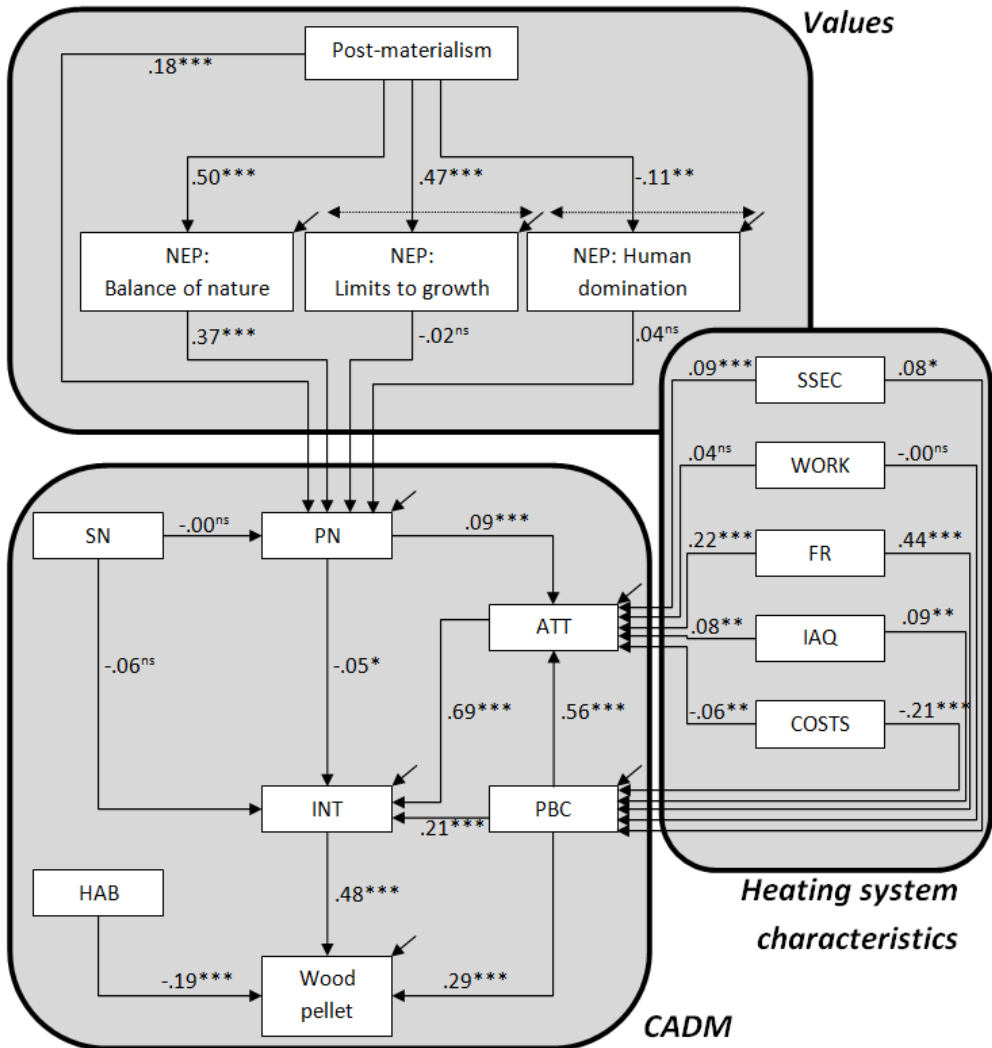

Fig. 1 The tested combination of CADM, heating system characteristics, and basic and ecological values (post-materialism & NEP) to model the decision for wood pellet heating. The displayed numbers are standardized regression weights in a path analysis ($N=737$).

Table 1 Means and standard deviations of the variables in the path analysis, Cronbach's alpha is given where the variable is the sum score of at least two items (N=737).

	<i>M</i>	<i>SD</i>	Cronbach's alpha	range of score
INT	10.23	3.87	0.92	2-14
HAB	0.15	0.36	single item (dichotomous)	0/1
PBC	10.98	3.25	0.77	2-14
ATT	10.60	3.20	0.82	2-14
PN	9.50	2.90	0.82	2-14
SN	2.39	1.07	single item	1-6
SSEC	8.41	2.97	0.82	2-14
WORK	7.77	3.22	0.74	2-14
FR	10.62	2.69	0.85	2-14
IAQ	9.87	2.56	0.51	2-14
COSTS	7.12	3.19	0.66	2-14
NEP _{BON}	8.34	1.62	0.63	2-10
NEP _{LTG}	8.01	1.75	0.67	2-10
NEP _{HD}	4.78	2.17	0.71	2-10
PMAT	23.15	3.51	0.66	6-30

4. Results

Table 2 and Figure 1 display the results of the path analysis. All of the hypothesized influences show as expected with exception of the social norms, two out of three NEP subscales, and the amount of maintenance and operational work. The integrated model can explain 56% in the variance of underlying continuous probit variable constituting the choice of

wood pellet heating and therefore qualifies as a good approach to predict the choice of wood pellet heating. The most important predictor of the decision to use wood pellet heating is the intention. The influence of perceived behavioral control is weaker but significant as is the negative influence of habits.

Attitudes are by far the most important predictor of the intention to use wood pellet heating followed by perceived behavioral control. The influence of perceived behavioral control on intentions is to a larger extent mediated by attitudes (due to their substantial overlap this is not surprising – see Appendix B). The influence of personal norms on intention is also mediated by attitudes. However, an unexpected negative direct effect of personal norms on intention remains. Against our expectations social norms are not related to personal norms and intentions. One out of three NEP sub-scales (balance of nature) predicts personal norms significantly; the others fail to show a direct effect. There is, however, a very high correlation between NEP_{BON} and NEP_{LTG} , which indicates that the expected three-dimensional structure has to be rejected. The degree of post-materialism, as expected, has an indirect effect on personal norms, mediated by NEP_{BON} , but a significant direct influence remains. All technology characteristics but the amount of work related to wood pellet heating have the expected influences on attitude and perceived behavioral control. Functional reliability has the strongest impact, especially on perceived behavioral control. Substantial amounts of variance are predicted in most dependent variables in the path analysis.

Table 2 Unstandardized and standardized regression weights, standard errors, p-level and estimated R^2 of the path analysis (N=737).

	<i>B</i>	<i>SE</i>	beta	<i>p</i>		R^2
Wood pellet ← INT	0.15	0.01	0.48	<.001	***	
Wood pellet ← HAB	-0.66	0.15	-0.19	<.001	***	
Wood pellet ← PBC	0.10	0.02	0.29	<.001	***	
Wood pellet						0.56
INT ← PN	-0.06	0.03	-0.05	.027	*	
INT ← SN	-0.23	0.12	-0.06	.053		

INT ← ATT	0.81	0.04	0.69	<.001	***	
INT ← PBC	0.25	0.03	0.21	<.001	***	
INT						0.75
ATT ← SSEC	0.09	0.03	0.09	<.001	***	
ATT ← WORK	0.04	0.03	0.04	.144		
ATT ← FR	0.27	0.03	0.22	<.001	***	
ATT ← IAQ	0.10	0.03	0.08	.001	**	
ATT ← COSTS	-0.07	0.03	-0.06	.007	**	
ATT ← PBC	0.56	0.02	0.56	<.001	***	
ATT ← PN	0.11	0.03	0.09	<.001	***	
ATT						0.65
PBC ← SSEC	0.09	0.04	0.08	.010	*	
PBC ← WORK	-0.00	0.04	-0.00	.942		
PBC ← FR	0.55	0.04	0.44	<.001	***	
PBC ← IAQ	0.12	0.04	0.09	.006	**	
PBC ← COSTS	-0.22	0.03	-0.21	<.001	***	
PBC						0.40
PN ← SN	-0.00	0.09	0.00	.973		
PN ← NEP _{BON}	0.67	0.07	0.37	<.001	***	
PN ← NEP _{LTG}	-0.03	0.06	-0.02	.666		
PN ← NEP _{HD}	0.05	0.04	0.04	.198		
PN ← PMAT	0.15	0.03	0.18	<.001	***	
PN						0.22
NEP _{BON} ← PMAT	0.23	0.02	0.50	<.001	***	
NEP _{BON}						0.25

NEP _{LTG} ← PMAT	0.24	0.02	0.47	<.001	***	
NEP _{LTG}						0.22
NEP _{HD} ← PMAT	-0.07	0.02	-0.11	.002	**	
NEP _{HD}						0.01
NEP _{BON} ↔ NEP _{LTG}	0.92	0.08	0.46	<.001	***	
NEP _{BON} ↔ NEP _{HD}	-0.21	0.09	-0.08	.021	*	
NEP _{LTG} ↔ NEP _{HD}	-0.01	0.11	-0.00	.936		

*** p<.001; ** p<.01; * p<.05

Model fit indices presented in Table 3 indicate an acceptable fit of model and empirical data. This means that the proposed model is capable of reproducing the observed variance-covariance matrix to a large extend.³

Table 3 Model fit indices of the tested path model.

	Index
<i>Chi²/df/p</i>	106.772 / 36 ^a / <.001
<i>CFI</i>	0.949
<i>TLI</i>	0.936
<i>RMSEA</i>	0.052 ^b

^a Due to the WLSMV-estimator the degrees of freedom for the chi²-test have to be estimated (see the technical appendix to the MPLUS users guide for more advice, Muthen & Muthen, 1998-2007)

^b Due to the WLSMV-estimator a confidence interval for the RMSEA index could not be computed.

5. Discussion

The goal of the present study was to test a proposed complex model of technological and psychological characteristics predicting wood pellet heating adoption in Norwegian households. The integrated model combining CADM, perceived technological characteristics of wood pellet heating as well as values was tested against empirical data using a path analysis. The results (see Table 2) indicated that the model received reasonable support by the empirical data and is able to explain 56% of variation in the variable underlying heating system choice. This implies that the integrated model is a promising approach to explain choice behavior of wood pellet heating and analyzing its diffusion processes.

Although the analysis is based on correlational data only and thus does not allow inference of causal relations the results (Figure 1) seem to indicate, that the adoption of wood pellet heating is a process that is mainly guided by the “technology characteristics translated into attitudes translated into intentions” chain. The process is to a large extent characterized by rational decision making, weighing up the pros and cons of different heating technologies with respect to their technological characteristics. Not all information is, however, processed along the lines of attitude formation: a substantial amount of information processing seems to go along perceived control. Some of the heating system characteristics (functional reliability and costs) seem to be even more important for forming a representation of control, which means how much a person feels capable of showing a behavior, than they are for forming an attitude. That means that even if a possible adopter of wood pellet heating formed a positive attitude towards wood pellet heating the subjective evaluation of functional reliability and costs could interfere with acting according to the positive attitude. Another important finding is that even if the influence of habits, as expected, is small in magnitude compared to the impact of intentions and perceived behavioral control, it has still a significant impact. Even if habits are conceptualized differently in the present study than in previous studies [21], the reduction of complexity in the decision making process indicated by using a repetitive strategy was demonstrated to have an impact in disfavor of new technologies. This may indicate a cognitive lock-in of some people, which was also demonstrated in previous research [25,26]. Traditionalized heating system choices (such as the reliance on electrical heating in Norway) could therefore interfere with the adoption process. General values influence behavior mediated by several sub-steps, confirming that values affect behavior indirectly through

specific values, norms and intention [33,46]. The influence of values and norms on the decision process is minor (although mostly as theoretically expected). Personal norms have only a weak impact on attitudes. The mediated impact of basic or environmental values is even smaller. This means that strengthening environmental values and norms seems not to be a promising driver of the diffusion of wood pellet heating, at least not in a situation with such limited market share and weak social support of wood pellet users.

Although the analysis confirmed most of our hypotheses stated in the theoretical background, some results were unexpected. Those will be addressed in the following paragraph. Firstly, there is the unexpected negative direct influence of personal norms on intention (parallel to the expected positive influence mediated by attitudes). This seems to be a slight negative suppressor effect that should not be interpreted theoretically.⁴ The correlation table in Appendix B indicates that the bivariate correlation between heating system choice and personal norms is positive as expected. Similar suppressor effects have been shown before [24] and might have been caused by a relevant overlap between personal norms and other variables. Secondly, social norm lacks to have a significant influence on personal norm and intention. This contradicts the results by Ek and Söderholm [47] revealing that social influence affects individual consumption behavior in the green energy market. We attribute our finding to the unusual operationalization of social norms in the present study (estimated amount of influence), which was chosen due to needs outside the scope of the analysis reported here. As the direction of the social influence is not specified it could be that social influence in favor and in disfavor of wood pellet heating even out. Thirdly, at least the missing influence of the NEP subscale “limits to growth” on personal norms can be explained by the obvious lack of a three dimensional structure. Balance of nature and limits to growth correlate so strongly that they cannot be differentiated into two factors. This finding is much in line with arguments presented by Dunlap et al. [48] They propose that the structure of the NEP is one dimensional (in spite of other research findings) and that the very common two dimensional structure with “human domination” as additional factor is a methodological artifact caused by the negative wording of the subscales items. This would explain why all shared variation between personal norms and the NEP subscale is captured by the strongest subscale “balance of nature”. Finally, the insignificant relation between the evaluation of work connected to wood pellet heating and attitudes and perceived behavioral control could mean that this aspect is not relevant in the

evaluation process or that variation between people on this aspect is to such a large amount overlapping with the other aspects that its influence is sufficiently captured by them (see Appendix B for correlations of “work” with the other heating system characteristics).

Although the study presented here offers an interesting and promising perspective on the adoption of wood pellet heating, some limitations have to be discussed: Firstly, the adoption process is modeled retrospectively which makes the validity of the results questionable to a certain extent. Maybe, wood pellet users adapted their cognitive mind set, their attitudes etc. after they made the decision for wood pellet heating. As the temporal order of events in the present study is reversed in the analysis and data is analyzed on a correlational basis, no conclusion about causal relations can be drawn. Thus, a study following people through the process of deciding for a heating system and measuring the variables several times throughout the process would be extremely insightful. We are nevertheless convinced that the structure of the model holds, because it could be replicated in other domains (travel mode choice and waste recycling) where behavior was predicted prospectively [21,29]. Secondly, although variance in attitude is predicted by 65% and variance in perceived behavioral control by 40%, the selection of heating system characteristics is far from being complete. Other aspects like design, image, space in the house to install the stove, etc. might be important that were not included in the present study. Rakos [49] reported that one of the factors that contributed to the success of wood pellet heating in Austria were technological characteristics, such as fully automatic operation, beautiful design, and the high quality and comfort offered by wood pellet heating. Thirdly, it has to be analyzed how specific the results are to Norway and the wood pellet technology studied here. Can the proposed model be applied to diffusion of other technologies? Can it be applied to other countries? We expect that the model structure should be stable over products and countries, but that the importance of the different components might vary. The impact of habits should for example be the stronger, the more often implementation behavior is shown. Maybe, the influence of values and norms is stronger in technology domains that are closer to people’s self definition (for example in medicine). Maybe, social norms have a stronger influence when the market share of a product is higher, especially if the product becomes part of a certain life style (as the iPhone for example).

For the diffusion of wood pellet technology in Norway the results may have important implications. If the Norwegian government wants to speed up the diffusion process,

improvement of the subjective evaluation of the functional reliability and the costs related to wood pellet heating should have first priority. Focusing on values or norms should not be of highest priority at the moment, but might be later, when the market share is larger and a significant number of people use wood pellet heating that could form a social reference group proposing the environmental values of wood pellet heating. Then people with most post-materialistic values would be the most likely candidates to adopt wood pellet heating. Considering the small but significant influence of habitual decision making it could be important to motivate people to actually actively make a choice when they are about to install a new heating system and reduce cognitive lock-in. Procedures reducing customer loyalty in decision making which might be considered as an example of such a lock-in have been discussed in Gärling et al. [26]. Presenting alternatives and increase decisional involvement could be other promising strategies.

6. Acknowledgment

Financial support provided by Norwegian University of Science and Technology (NTNU), Norway, is gratefully acknowledged.

Footnotes

¹ A residual covariance was modeled for the three sub-dimensions of the NEP scale to cover the theoretical discussion that they might constitute one dimension only.

² The sample used for the present study is to a large extent identical to the sample used for the study reported in Sopha et al. [50]. However, the analysis in the present study is built on different variables.

³ The fit of the model was evaluated using different types of fit indexes including the relative chi-square (normal or normed chi-square), comparative fit index (CFI), Tucker-Lewis Index (TLI), and root mean square error of approximation (RMSEA). Different researchers have recommended using relative chi-square to degrees of freedom ratio as low as 2 or as high as 5 to indicate a reasonable fit [51-53]. The ratio in the present study is approximately 3 and lies within this margin. The Chi²-test comes out significant due to the sample size. CFI and TLI were chosen as additional model fit indices because they are independent of sample size or

less sensitive to sample size. CFI and TLI should be equal to or greater than .90 in order for the model to be accepted [54], and in this case is satisfied for both measures. Following convention a RMSEA less than or equal to .08 were judged as providing a reasonable fit to the data, again was met in this analysis.

⁴ Such suppressor effects are common in analyses using the WLSMV estimator.

7. References

- [1] Larsen BM, Nesbakken R. Formålsfordeling av husholdningenes elektrisitetsforbruk i 1990 og 2001. *Økonomiske Analyser*, 4/2005; 2005. Available from <http://www.ssb.no/emner/08/05/10/oa/200504/nesbakken.pdf> (in Norwegian)
- [2] REMODECE Project; 2006. Retrieved in October 2009. Available from <http://www.sintef.net/Olje-og-energi/SINTEF-Energiforskning-AS/Prosjektarbeid/USELOAD-/REMODECE/>
- [3] Jamasb T, Pollitt M. Security of supply and regulation of energy networks. *Energy Policy* 2008; 36 (12): 4584-4589.
- [4] Statistics Norway, 2006. Retrieved in June 2008. Available from <http://www.ssb.no/>
- [5] Mahapatra K, Gustavsson L, Madlener R. Bioenergy innovations: The case of wood pellet systems in Sweden. *Technology Analysis & Strategic Management* 2007; 19 (1): 99-125.
- [6] Rakos C. The diffusion of biomass district heating in Austria, Project Report to the European Commission, Institute of Technology Assessment, Austrian Academy of Sciences, Vienna; 1995.
- [7] Egger C, Öhlinger C, Dell G. Wood Pellets-tomorrow's fuel. *Renewable Energy World*, September-October 2003. Available from: http://www.investinnorthbay.ca/workforce/doc/BIO_MASS/Wood%20Pellets%20To%20morrow's%20Fuel.pdf

- [8] Alakangas E, Paju P. Wood pellets in Finland- technology, economy and market. OPET Report 5, VTT Processes, Jyväskylä; 2002. Retrieved in October 2007. Available from www.tekes.fi/opet/pdf/OPET_report5_june2002.pdf
- [9] Nashoug H, Pedersen FD. Opportunities and barriers for development of a Norwegian wood pellet market, Thesis, Institutt for Økonomi og Samfunnsfag, NLH; 2004. (in Norwegian)
- [10] Bjerg J, Evald A. Denmark – Market and technology trends in the Danish pellets market, European Pellets Conference 2004; 2004.
- [11] Johns KD, Khovanova KM, Welch EW. Fleet conversion in local government: Determinants of driver fuel choice of bi-fuel vehicles. *Environment and Behavior* 2009; 41 (3): 402-426
- [12] Wilson C, Dowlatabadi H. Models of decision making and residential energy use. *Annual Review Environmental Resource* 2007; 32: 169-203.
- [13] Nyrud AQ, Roos A, Sande JB. Residential bioenergy heating: A study of consumer perceptions. *Energy Policy* 2008; 36: 3169-3176.
- [14] Rogers E. *Diffusion of Innovations*, 4th ed., New York: Free Press; 1995.
- [15] Jeyaraj A, Rottman J, Lacity M. A review of predictors, linkages and biases in IT innovation adoption research. *Journal of Information Technology* 2006; 21 (1): 1-23.
- [16] Tapaninen A, Seppänen M, Mäkinen S. Characteristics of innovation: a customer-centric view of barriers to the adoption of a renewable energy system. *International Journal of Agile Systems and Management* 2009; 4: 98-113.
- [17] Kasanen P, Lakshmanan TR. Residential Heating Choices of Finnish Household. *Economic Geography* 1989; 65 (2): 130-145.
- [18] Ajzen I. The theory of planned behavior. *Organizational Behavior and Human Decision Process* 1991; 50: 179-211.

- [19] Schwartz SH, Howard JA. A normative decision-making model of altruism. In J.P. Rushton (Editor): *Altruism and helping behavior. Social, personality and developmental perspectives*. Erlbaum, Hillsdale, New York; 1981.
- [20] Frey BS. Ipsative and objective limits to human behavior. *Journal of Behavioral Economics* 1988; 4: 229-248.
- [21] Klöckner CA, Blöbaum. A comprehensive action determination model – towards a broader understanding of ecological behavior using the example of travel mode choice, *Journal of Environmental Psychology*.
- [22] Verplanken B, Wood W. Interventions to break and create consumer habits. *Journal of Public Policy & Marketing* 2006; 25 (1): 90-103.
- [23] Bamberg S, Möser G. Twenty years after Hines, Hungerford, and Tomera: A new meta-analysis of psycho-social determinants of pro-environmental behaviour. *Journal of Environmental Psychology* 2007; 27: 14-25.
- [24] Heath Y, Gifford R. Extending the theory of planned behaviour: Predicting the use of public transportation. *Journal of Applied Social Psychology* 2002; 32: 2154-2189.
- [25] Johnson EJ, Bellman S, Lohse GL. Cognitive lock-in and the power law of practice. *Journal of Marketing* 2003; 67: 62-75.
- [26] Gärling T, Gamble A, Juliusson EA. Consumers' switching inertia in a fictitious electricity market. *International Journal of Consumer Studies* 2008; 32: 613-618.
- [27] Verplanken B, Aarts H. Habit, attitude, and planned behaviour: Is habit an empty construct or an interesting case of goal-directed automaticity? *European Review of Social Psychology* 1999; 10: 101-134.
- [28] Klöckner CA, Friedrichsmeier T. *A multilevel approach to travel mode choice – how person characteristics and situation specific aspects determine car use in a student sample*. Submitted for publication.

- [29] Klöckner CA, Oppedal IO. *General versus domain specific recycling behaviour – applying a multilevel comprehensive action determination model to recycling in Norwegian student homes*. Submitted for publication
- [30] Klöckner CA. Understanding the purchase of organic food – a theoretical framework from a psychological perspective. *Food Science Central online features*; 2010. Available from <http://www.foodsciencecentral.com/fsc/ixid15967>
- [31] Hardin G. The tragedy of the commons. *Science* 1968; 162: 1243-1248. Accessed in November 2009. Available from <http://www.sciencemag.org/cgi/content/full/162/3859/1243>
- [32] Clark CF, Kotchen MJ, Moore MR. Internal and external influences on pro-environmental behaviour: Participation in a green electricity program. *Journal of Environmental Psychology* 2003; 23: 237-246.
- [33] Poortinga W, Steg L, Vlek C. Values, environmental concern, and environmental behavior: A study into household energy use. *Environment and Behavior* 2004; 36: 70-93.
- [34] Inglehart R, Rabier J-R. Political realignments in advanced industrial society: From class-based politics to quality-of-life politics. *Government and Opposition* 1986; 21: 456-79.
- [35] Inglehart R, Abramson PR. Measuring postmaterialism. *American Political Review* 1999; 93 (3): 665-677.
- [36] Hansla A, Gamble A, Juliusson A, Gärling T. Psychological determinants of attitude towards and willingness to pay for green electricity. *Energy Policy* 2008; 36: 768-774.
- [37] Dunlap RE, Van Liere KD. The “New Environmental Paradigm”: A proposed measuring instrument and preliminary results. *The Journal of Environmental Education* 1978; 9 (4): 10-19.
- [38] Geller J, Lasley P. The new environmental paradigm scale: a reexamination. *Journal of Environmental Education* 1985; 17 (1): 9-12.

- [39] Dunlap RE. The New Environmental Paradigm Scale: from marginality to worldwide use. *The Journal of Environmental Education* 2008; 40 (1): 3-18.
- [40] Stern PC, Dietz T, Abel T, Guagnano GA, Kalof L. A Value-belief-norm theory of support for social movements: The case of environmentalism. *Human Ecology Review* 1999; 6 (2): 81-96.
- [41] Marsh HW, Kau K-T, Balla JR, Grayson D. Is more ever too much? The number of indicators per factor in confirmatory factor analysis. *Multivariate Behavioral Research* 1998; 33 (2): 181-220.
- [42] Muthén LK, Muthén BO. *Mplus User's Guide. Fifth Edition*. Los Angeles, CA: Muthén & Muthén; 1998-2007.
- [43] Moore G, Benbasat I. Development of an instrument to measure the perceptions of adopting an information technology innovation. *Information Systems Research* 1991, 2 (3), 192-222.
- [44] Vogel S. Environmental attitudes and behaviour in the agricultural sector empirically determined by use of an attitude model, Diskussionpapier Nr. 32-W-94; 1994. Accessed in June 2008. Available from http://www.boku.ac.at/wpr/papers/d_papers/dp_cont_html
- [45] Lalonde R, Jackson EL. The new environmental paradigm scale: Has it outlived its usefulness? *The Journal of Environmental Education* 2002, 33 (4), 28-36.
- [46] Nordlund AM, Garvill J. Value structures behind environmental behavior. *Environment and Behavior* 2002; 34: 740-756.
- [47] Ek K, Söderholm P. Norms and economic motivation in the Swedish green electricity market. *Ecological Economics* 2008; 68: 169-182.
- [48] Dunlap RE, Van Liere KD, Mertig AG, Jones RE. Measuring endorsement of the New Ecological Paradigm: a revised NEP scale. *The Journal of Social Issues* 2000; 56 (3): 425-442.

- [49] Rakos C. *Pellet – a new star on the renewable energy sky*. The Austrian Energy Agency E.V.A.; 2009. Accessed in November 2009. Available from http://www.bioheat.info/pdf/rakos_success_wp.pdf
- [50] Sopha BM, Klöckner CA, Skjevrak CA, Hertwich EG. Norwegian households' perception of wood pellet stove compared to air-to-air heat pump and electric heating. *Energy Policy* 2010; 38 (7): 3744-3754.
- [51] Wheaton B, Muthén B, Alwin DF, Summers GF. Assessing reliability and stability in panel models. In D.R. Heise (editor): *Sociological methodology*. San Francisco: Jossey-Bass; 1977.
- [52] Schumacker RE, Lomax RG. *A beginner's guide to structural equation modeling, Second edition*. Mahwah, NJ: Lawrence Erlbaum Associates; 2004.
- [53] Marsh HW, Hocevar D. Application of confirmatory factor analysis to the study of self-concept: First- and higher order factor models and their invariance across groups. *Psychological Bulletin* 1985; 97: 562-582.
- [54] Fan X, Thompson B, Wang L. Effects of sample size, estimation method, and model specification on structural equation modeling fit indexes. *Structural Equation Modeling* 1999; 6: 56-83.

Appendix A

Likert scale coded as 1 (totally disagree) - 7 (totally agree)

Personal Ecological Norm

1. Due to my values/principles I feel personally obliged to use an environmentally friendly heating system.

2. The aspect of environmental protection in deciding for a heating system is solidly anchored in my value system.

Intention

1. When I decide next time for a new heating system, my intention to use wood pellet heating is strong
2. I intent to use wood pellet heating.

Attitudes

1. It would be good using wood pellet heating
2. It would be valuable to use wood pellet heating

Perceived Behavioral Control

1. If I wanted I could easily use wood pellet heating
2. It would be easy to meet my need for home heating using wood pellet heating

Functional Reliability – the degree to which wood pellet heating is reliable

1. I think that wood pellet heating results in less breakdowns
2. Wood pellet heating is reliable

Indoor Air Quality – the degree to which wood pellet heating provides high indoor air quality

1. Poor quality of indoor air is produced by wood pellet heating
2. Using wood pellet heating results in clean and not too dry indoor air

Total Cost (Investment and Operational Cost) – the degree to which wood pellet heating is affordable

1. Wood pellet heating is too expensive to have
2. I believe that wood pellet heating would cost more than I could afford

Work related to operation and maintenance – the degree to which wood pellet heating requires work related to operation and maintenance

1. I would have to do operation and maintenance work if I am using wood pellet heating
2. Lots of work related to operation and maintenance is required for wood pellet heating

Supply Security – the degree to which the fuel for wood pellet heating is easy to find with stable price

1. It is easy to find the fuel with the stable price for wood pellet heating
2. The fuel for wood pellet heating is available with almost the same price

Likert scale coded as 1 (totally disagree) - 5 (totally agree)

Degree of post-materialism value

How should our society look?

1. A society that gives higher priority to environmental protection than to economic development
2. A society that tries to create prosperity but not at the cost of risk
3. A society that in the first instance emphasizes job satisfaction as the fruit of human labor
4. A society in which individuals are judged primarily on the basis of their human qualities
5. A society with numerous possibilities for citizens to take part in the political process
6. A society that makes an effort to maintain nature as it is

New Environmental Paradigm (NEP)

Balance of nature:

1. Human must live in harmony with nature in order to survive
2. Humankind is severely abusing the environment

Limits to growth:

1. The earth is like a spaceship with only limited room and resources
2. There are limits to growth beyond which our industrialized society cannot expand

Human domination:

1. Humankind was created to rule over the rest of nature
2. Plants and animals exist primarily to be used by humans

Appendix B

Correlation table of scales and constructs ($N=737$).

	a)	b)	c)	d)	e)	f)	g)	h)	i)	j)	k)	l)	m)	n)	o)	p)
a) Wood pellet																
b) INT	.71 ***															
c) HAB	-.29 ***	-.17 **														
d) PBC	.66 ***	.75 ***	-.08													
e) ATT	.61 ***	.85 ***	-.15 **	.77 ***												
f) PN	.13 **	.17 ***	-.10 *	.16 ***	.24 ***											
g) SN	.10 *	-.11 **	-.26 ***	-.09 **	-.06 **	-.01										
h) SSEC	.29 ***	.40 ***	.00	.35 ***	.40 ***	.17 ***	-.10 **									
i) WORK	-.29 ***	-.36 ***	.02	-.37 ***	-.36 ***	-.10 **	.07 *	-.27 ***								
j) FR	.37 ***	.58 ***	.05	.59 ***	.62 ***	.22 ***	-.08 **	.42 ***	-.51 ***							
k) IAQ	.34 ***	.38 ***	-.12 *	.33 ***	.37 ***	.13 ***	-.07 *	.26 ***	-.36 ***	.39 ***						
l) COSTS	-.41 ***	-.39 ***	.16 **	-.40 ***	-.38 ***	-.09 **	.08 *	-.31 ***	.42 ***	-.33 ***	-.29 ***					
m) NEP _{BON}	.03	.08	-.12	.08	.13	.41	.05	.04	.03	.03	.05	-.10 **				
n) NEP _{LTG}	.03	.03	-.06	.06	.11	.27	.05	.05	-.01	.08	.03	-.05	-.10 **	.59 ***		
					**	***			*	*						

o) NEP _{HD}	.04	.07	.07	.06	.04	-.01	-.02	.06	-.01	.02	-.00	.09	-.12	-.04
		*						*				**	***	
p) PMAT	.03	.07	-.10	.07	.14	.34	.00	.13	-.04	.10	.08	-.03	.49	.48
					***	***		***		**	*		***	***

[†] the variable is dichotomous: no variance is calculated, correlations are based on logits

*** p<.001, ** p<.01, * p<.05

**Norwegian Households' Perception of Wood Pellet Stove Compared to
Air-to-air Heat Pump and Electric Heating**

Bertha Maya Sopha

*Industrial Ecology Programme and Department of Energy and Process Engineering
Norwegian University of Science and Technology
N-7491 Trondheim, Norway*

Christian A. Klöckner

*Department of Psychology, Section for Risk Psychology, Environment and Safety
(RIPENSA)
Norwegian University of Science and Technology
N-7491 Trondheim, Norway*

Geir Skjevraak

*Department of Energy and Process Engineering
Norwegian University of Science and Technology
N-7491 Trondheim, Norway*

Edgar G. Hertwich

*Industrial Ecology Programme and Department of Energy and Process Engineering
Norwegian University of Science and Technology
N-7491 Trondheim, Norway*



Contents lists available at ScienceDirect

Energy Policy

journal homepage: www.elsevier.com/locate/enpol

Norwegian households' perception of wood pellet stove compared to air-to-air heat pump and electric heating

Bertha Maya Sopha^{a,b,*}, Christian A. Klöckner^c, Geir Skjevraak^b, Edgar G. Hertwich^{a,b}

^a Industrial Ecology Programme, Norwegian University of Science and Technology, NO-7491 Trondheim, Norway

^b Department of Energy and Process Engineering, Norwegian University of Science and Technology, NO-7491 Trondheim, Norway

^c Department of Psychology, Section for Risk Psychology, Environment and Safety (RIPENSA), Norwegian University of Science and Technology, NO-7491 Trondheim, Norway

ARTICLE INFO

Article history:

Received 5 October 2009

Accepted 24 February 2010

Available online 12 March 2010

Keywords:

Norwegian perception

Heating choices

Multinomial logistic regression (MLR)

ABSTRACT

In 2003, the high dependency on electric heating combined with the high electricity price prompted a significant number of Norwegian households to consider alternative heating systems. The government introduced economic support for wood pellet heating and heat pumps. In contrast to the fast growing heat pump market, this financial support has not resulted in a widespread adoption of wood pellet heating. This paper studies factors that influence the choice of heating system based on Norwegian households' perceptions. Electric heating, heat pump and wood pellet heating were compared, with a special focus on wood pellet heating. This study was conducted as a questionnaire survey on two independent samples. The first sample consisted of 188 randomly chosen Norwegian households, mainly using electric heating; the second sample consisted of 461 households using wood pellet heating. Our results show that socio-demographic factors, communication among households, the perceived importance of heating system attributes, and the applied decision strategy all influence the Norwegian homeowners. The significance of these factors differs between the two samples and the preferred type of anticipated future heating system. Strategies for possible interventions and policy initiatives are discussed.

© 2010 Elsevier Ltd. All rights reserved.

1. Introduction

Norwegian public investment in the construction of hydro-power plants between 1960 and 1990 provided a large capacity of cheap electricity (Christiansen, 2002) and consequently led to an increased dependency on electricity for heating. Approximately 70% of Norwegian households use electricity as the main heating source, especially in the residential sector (Statistics Norway, 2006). Because the demand for electricity has grown to match the average supply and because the production is significantly affected by precipitation, Norway is at times a net exporter of energy. However, when energy consumption exceeds production, Norway imports energy. While the Norwegian production of electricity is almost 100% regenerative, the imported energy is generated from various sources including nuclear power and fossil fuel. Several grids have been built to facilitate future electricity exports to other European countries because it is

argued that every kWh of electricity exported replaces a kWh of electricity produced abroad based on fossil energy sources.

Even as Norway occasionally imports electricity from other countries, it has enormous bio-energy resources in its forests. As heating accounts for approximately 50% of energy use in households (Larsen and Nesbakken, 2005; REMODECE Project, 2006), shifting the prevalent heating system from electric to renewable, e.g. wood pellet, can help mitigate environmental problems caused by importing energy and/or the construction of additional hydroelectric power plants. Thus, Norwegian government has supported alternative heating systems for households to overcome the electricity dependency and reduce electricity consumption. The choice of a particular heating system by Norwegian households is therefore an important issue.

The Norwegian Commission on Low Emissions has proposed a transition to CO₂-neutral heating through an increased use of heat pumps, wood pellets, thermal solar energy systems, etc. (Norwegian Strategy Group, 2006). Many attempts have been made to establish a market for heat pumps and wood pellet heating. Subsidies were introduced to defray the costs for individual households to install alternative heating systems and reduce electricity consumption. In 2003, Enova, established in 2001 as a public enterprise owned by the OED (Ministry of Petroleum and Energy), ran a subsidy scheme that provided for up

* Corresponding author at: Department of Energy and Process Engineering, Norwegian University of Science and Technology, NO-7491 Trondheim, Norway.
E-mail addresses: bertha.sopha@ntnu.no, bertha_mamun@yahoo.com (B.M. Sopha).

to 20% of the total investment costs for all types of heat pumps and wood pellet heating solutions (Innstilling til Stortinget fra energi-og miljøkomiteen nr. 133, 2002–2003). The number of installations of air-to-air heat pumps more than doubled between 2002 and 2003. This boost was mainly caused by subsidies accompanied by an increase in the price of electricity (Markusson et al., 2009). As the market share of air-to-air heat pumps increased significantly, the subsidy scheme was discontinued in 2007. Although the market development of wood pellet stoves was much less dynamic, the subsidies for wood pellet systems did not go uninterrupted due to a lack of funding and claims by the organization of ordinary wood-stove manufacturers that the government should also provide subsidies for ordinary wood stoves. At the same time, Norway is steadily increasing its wood pellet production (Peksa-Blanchard et al., 2007) which improves the availability of wood pellets in the market. Despite these interventions, the market diffusion of wood pellet heating has been rather slow. It is reported that in 2006 only 3 out of 1000 households had pellet stoves (Statistics Norway, 2006).

This paper first aims to identify factors motivating current users of electric heating system to choose either air-to-air heat pump or wood pellet as a replacement heating system. The second goal is to identify factors motivating wood pellet users to shift their main heating system away from wood pellet heating and back to either an electric heating or an air-to-air heat pump. This study contributes to the understanding of the rationale that causes a Norwegian household to choose one type of heating system over another. Three types of heating systems are examined: direct electric heating (the standard technology), individual wood pellet stove (hereafter used interchangeably with wood pellet heating), and air-to-air heat pump (hereafter referred to as heat pump). Wood pellet stove and heat pump were chosen because these two systems are the most commonly used alternatives to electric heating in Norway. However, the paper focuses on wood pellet heating rather than on heat pump because the adoption of the latter has been much faster than that of the former. For this reason no sample of heat pump users was surveyed.

2. Theoretical background

Understanding consumer choice is a pre-requisite to develop strategies to encourage pro-environmental consumer behavior. Purchasing decisions are made at either the individual or the household level. Household decision making differs from individual decision making because households often consist of several members who may have different preferences, and consequently the final decision usually represents a compromise, in the same way that children might influence the choice of a holiday destination. Lackman and Lanasa (1993) indicated that many purchasing decisions of families were not the outcome of an individual choice but influenced to a great extent by other family members. Lindhjem and Navrud (2009) documented that the two primary explanations for why Norwegian households favored environmental goods more than individuals were that incomes of both adults and the partner's opinion were taken into account. As the selection of heating system usually requires a large financial investment, and includes at least two adult members of a household, this decision is defined as a decision taken at a household level for the purpose of further discussion.

Previous Norwegian studies and other studies on the choice of heating system have focused on socio-demographic factors, household characteristics, communication and heating systems attributes as influencing factors (Brottemsmo, 1994; Nesbakken and Strøm, 1994; Nesbakken, 1998; Kasanen and Lakshmanan,

1989; Scodari and Hardie, 1985; Mahapatra and Gustavsson, 2008). Based on previous studies, factors from four different areas are taken into consideration in order to explain the choice of heating system: socio-demographic factors, communication among households, heating system attributes, and the decision strategy applied by the households.

2.1. Socio-demographic factors

Previous studies on the choice of heating system have been able to show that a number of socio-demographic factors such as age, income, education and region influence this decision (Mahapatra and Gustavsson, 2008; Scodari and Hardie, 1985; Nesbakken and Strøm, 1994; Kasanen and Lakshmanan, 1989). Age is relevant as older people can be expected to be more traditional than young people with respect to the acceptance of new technologies (Brown and Venkatesh, 2005). Since wood pellet heating and heat pump are considered as emerging technologies, age is anticipated to be a possible factor in this study. Household income strongly affected investment behavior for heating in the previous study conducted by Nesbakken and Strøm (1994) as those with a high income level preferring electric heating. The total income of the household rather than just the income of the head of the household is measured in this study, to provide a more realistic figure of the available resources. Prior results regarding the influence of educational level on the choice of a heating system are inconclusive. Scodari and Hardie (1985) demonstrated that education had an inverse effect on the probability of a household to acquire a wood stove. It could be that well-educated people in New Hampshire lived more often in larger cities where wood heating seemed less appropriate or practical. A Finland case studied by Kasanen and Lakshmanan (1989) confirmed that people with a higher educational background who lived in urban areas and Western Finland tend to choose modern systems at that time, i.e. central heating with air or direct electric heating, rather than central heating with water. To further investigate this factor, the educational level was included.

In addition to socio-demographic factors, regional differences constitute another important determinant as regional constraints might limit the selectable alternatives. Kasanen and Lakshmanan (1989) showed that the conservatism and relative prosperity of Western Finland may explain why this region is more in favor of central heating than other regions. Furthermore, it is also expected that regional differences in climate and resource availability affect the choice. In the north and inland of Norway, the average temperature is lower than in the south and the coastal regions. This causes variations in heating needs, which in turn affects the costs of alternatives. With respect to resource availability, even though wood pellets could technically be transported anywhere in the country, the transportation costs may become prohibitive in remote areas. Region, as a variable covering spatial variations, was therefore included in this study.

2.2. Communication influencing adoption

A recent study of Swedish households applied the innovation-decision model (Rogers, 2003) to discuss various factors influencing the choice of a heating system, i.e. socio-economic, mass media and interpersonal communication, as well as heating system attributes (Mahapatra and Gustavsson, 2008). According to (Rogers, 2003), communication habits influence consumers when it comes to adopting or rejecting an innovation. Interpersonal communication conveys not only information but also the degree and intensity of feelings and conviction. Consequently,

consumers often rated information gained through personal communication as most important, especially when they perceive a high risk, or when they are generally susceptible to interpersonal influence (Gilly et al., 1998). The number of peers to whom a household recommends a heating system is applied as a proxy of a household's communication habit in this study. This variable also reflects a household's satisfaction with a certain type of heating system because people are more likely to recommend a heating system to others if they are satisfied. On the contrary, if a household is dissatisfied with a certain heating system, it is likely to advise peers against buying it. The latter aspect was not included in the study.

2.3. Perceived importance of heating system attributes

Households also differ in what they perceive to be important heating system attributes when they are making their decision. According to (Rogers, 2003), innovation attributes can explain 49–87% of the variance of adoption. Many studies on wood pellet adoption have also indicated that perceived innovation attributes play a crucial role in the adoption (Mahapatra and Gustavsson, 2008; Kasanen and Lakshmanan, 1989; Tapaninen et al., 2009). Based on former studies on the choice of a heating system (Nesbakken and Strøm, 1994; Nesbakken, 1998; Kasanen and Lakshmanan, 1989; Mahapatra and Gustavsson, 2008), this study operationalizes the specific wood pellet heating attributes as follows: functional reliability, indoor air quality, investment costs, operation costs, upkeep work, and fuel supply security. We asked the respondents to estimate the subjective importance rather than about the performance of each heating system with respect to these attributes in order to identify the information on which households focus when making their choice.

2.4. Decision strategies influencing adoption

Lark (1989) pointed out that people make use of information when forming their expectations, but they differ in the way they exploit and in their abilities to process this information. Decision strategies, which were derived from consumer behavior theories, have been applied in diffusion simulation studies of green products (Janssen and Jager, 2002; Jager, 2006; Schwoon, 2006; Schwarz and Ernst, 2009). The four decision strategies, Repetition, Deliberation, Imitation and Social Comparison, as well as the circumstances people are most likely to engage them in, are discussed here. The four strategies are characterized by two main dimensions: reasoned vs. automated processing and individual vs. social processing (see Table 1). Reasoned processing implies that one is elaborating on need fulfillment, taking all possible alternatives into account. People are generally motivated to think about other alternatives when they are not satisfied with their current system (Janssen and Jager, 2002). On the contrary, automated processing implies that one is using relatively simple heuristics to make a decision, habitually repeating the originally deliberate choices as long as the results satisfy one's needs. Individual processing implies that the consumer is gathering and processing information without considering the behavior of others as a main source of information, whereas social

processing implies that the consumer is observing the behavior of others as a means to acquire information (Jager, 2000). Based on both dimensions the four types of decision strategy were derived.

Repetition: Consumers will habitually consume the product that they consumed previously. This process applies mainly to situations where consumers are highly satisfied with the product they have in use and are able to easily consume it, uncertainty is relatively low, product use is less publicly visible and the needs in question are more individually relevant. Therefore, finding alternative opportunities or increasing their own abilities is not necessary.

Deliberation: Consumers will evaluate all possible alternatives and consume the product with the highest need satisfaction. This process applies mainly to situations where consumers are dissatisfied with their current product and in which it is difficult to consume it, uncertainty is relatively low, product use is less publicly visible and the needs in question are more individually relevant. Thus, consumers are forced to look for alternative opportunities or increase their abilities.

Imitation: Consumers will consume the product that most of their social network consumes. This process applies mainly to situations where consumers are satisfied with the product they use and where it is easy to consume it, but the uncertainty is relatively high, product use is publicly visible and the needs in question are more socially relevant. Due to social network influence, a change occurring in the network will affect their behavior although the decision makers are relatively satisfied with current product.

Social comparison: Consumers will perform a social comparison by comparing the utility of the product previously consumed and the product that most of their social network consumes and selecting the product yielding the highest need satisfaction. This process applies mainly to situations where consumers are dissatisfied with the previously used product and where it is difficult to consume it, as well as where uncertainty is relatively high, product use is publicly visible and the needs in question are more socially relevant.

The decision strategy a household applies may affect the rate of adoption of a product or technology. For example, when households deliberate, they are likely to find out about an innovation in its early stage. When they engage in social processing, they may learn about the innovation from others later in the diffusion process, but if they habitually repeat their behavior they may remain unaware of the innovation. For this reason, the decision strategy that household use is a critical factor in the innovation adoption process. By identifying the decision strategy used by Norwegian households to purchase a heating system it is possible to identify interventions that may change consumers' behavior. Addition of this factor to the heating system choice model is a novel contribution of this study.

3. Data collection

Data was collected with a survey in 2008. A mail survey was chosen to acquire representative information on the national level, testing the influence of a combination of already established predictors from other studies (Brottemsmo, 1994; Nesbakken and Strøm, 1994; Nesbakken, 1998). A pilot study for testing and refining the written questionnaire was conducted first with 35 households. Then 1500 questionnaires were sent to Norwegian households drawn as a random sample from the population register. The sampling was done by the Norwegian research company Sentio. A random sample rather than a stratified random sample was chosen because we did not have access to

Table 1
Meta-theory (adapted from Jager, 2000).

Decision strategy	Automated processing	Reasoned processing
Individually determined	Repetition	Deliberation
Social determined	Imitation	Social comparison

stratification variables for Norwegian households during the sampling procedure. We increased sample size to compensate for the negative effect of sampling bias in a simple random sample (see Lohr, 2009, for a discussion of different sampling techniques). Only homeowners were chosen as respondents because they have the authority to make decisions about heating systems independently. This sample, hereafter referred to as population sample, represents households who do not use wood pellet heating. About 1500 additional questionnaires were sent to wood pellet users in Norway. The second sample represented almost the complete population of wood pellet users in Norway. The list was acquired from wood pellet companies in Norway.

After three weeks, the response rates in the population sample and wood pellet sample were 10.3 and 34.6%, respectively. Over 137 additional responses from the population sample and 150 from the wood pellet sample were received after a reminder was sent out. This resulted in a response rate of 19.4% (291 responses) for the population sample and 44.6% (669 responses) for the wood pellet sample. Participants with missing values in predictive variables had to be excluded from the study so that the final analysis is based on a population sample of 188 respondents and a wood pellet sample of 461 respondents.

3.1. Bias

To test if the random population sample of 1500 varied significantly from the regional distribution of all households in Norway, a χ^2 test comparing the distribution of households over Norway's nineteen provinces in the sample to the expected distribution based on data from population registry was conducted without a significant result ($\chi^2=17.633$; $df=18$; $p=0.480$). In other words, the composition of the original population sample was representative of the regional distribution of Norwegian households. Even though this is not the case for the wood pellet sample ($\chi^2=488.028$; $df=18$; $p<0.000$), this sample is representative of all Norwegian wood pellet users, as it accounts for roughly 80% of all wood pellet households in Norway.

To test possible self-selection effects, a chi-square test to compare the original and the response sample with respect to distribution of the provinces was also performed for both groups. The tests showed that there was no statistical difference between the original and the response population sample ($\chi^2=8.623$; $df=18$; $p=0.979$) and wood pellet sample ($\chi^2=2.122$; $df=18$; $p=0.999$). Thus, a self-selection bias with respect to regional distributions could not be found. Other data on the original population to test for self-selection bias in the response samples were not available. It might, therefore, be possible that self-selection processes resulted in an undetected bias, especially as the response rate in the two groups differed.

4. Empirical analysis

Multinomial Logistic Regression (MLR) was selected to deal with the 3-alternatives categorical nature of the dependent variable. The independent variables income, education, region, number of peers and decision strategy were dummy coded using the highest category as a reference. The continuous independent variables included were age and perceived importance of all heating system attributes. Tables 2 and 3 present the names and definitions of variables used in the analysis.

The empirical analysis was conducted in two parts. The first part of the analysis addressed the first objective of the paper, which is to identify factors that would motivate the population sample to choose environmental heating systems, either a heat pump or a wood pellet stove, as their future primary heating

Table 2

Names and definitions of dependent variable used in the analysis.

Category	Description
1	I would choose electric heating as my future heating system to replace my current heating system
2	I would choose a heat pump as my future heating system to replace my current heating system
3	I would choose wood pellet heating as my future heating system to replace my current heating system

Table 3

Names and definitions of independent variables used in the analysis.

Variable	Description
Socio-demographic factors	
Age	Respondent's age
Household income level	1=less than NOK 250 000 2=NOK 250 001–NOK 550 000 3=more than NOK 550 000
Education level	1=elementary school 2=high school 3=university
Regional group	1=Østfold, Åkerhus, Oslo, Hedmark, Oppland (East) 2=Buskerud, Vestfold, Telemark, Aust-Agder, Vest Agder (South) 3=Rogaland, Hordaland, Sogn og Fjordane (West) 4=More og Romsdal, Sør-Trøndelag, Nord-Trøndelag (Mid-Norway) 5=Nordland, Tromsø, Finnmark (North)
Communication	
Number of peers	Number of people to whom households recommended a heating system 1=0 2=1–5 peers 3=6–10 peers 4=11–15 peers 5=16–20 peers 6=more than 20 peers
Perceived importance of heating system attributes	
Functional reliability	The importance of functional reliability in the decision process (5-point Likert scale, high score=high importance)
Indoor air quality	The importance of indoor air quality in the decision process (5-point Likert scale, high score=high importance)
Investment costs	The importance of investment costs in the decision process (5-point Likert scale, high score=high importance)
Operation costs	The importance of operation costs in the decision process (5-point Likert scale, high score=high importance)
Upkeep work	The importance of upkeep work in the decision process (5-point Likert scale, high score=high importance)
Fuel supply security	The importance of fuel supply security (price and availability) in the decision process (5-point Likert scale, high score=high importance)
Decision strategy	
Decision strategy	1=choose the same as previous heating system (repetition) 2=choose heating system that has maximum utility (deliberation) 3=choose heating system that most neighbors/friends use (imitation) 4=compare the existing heating system to the one most neighbors/friends use and choose the best between the two (social comparison)

system. Electric heating is selected as a baseline category for the first MLR. The second analysis addresses the second objective, i.e. identifying factors that would motivate the wood pellet sample to choose either electric heating or a heat pump in the future. The baseline category for this analysis is therefore the wood pellet stove.

5. Results

Tables 4, 5 and 6 present profiles of the population sample and the wood pellet sample based on responses to the dependent and independent variables in the survey. The *Chi*² tests in Tables 4 and 5 represent a test of the assumption that the wood pellet sample has the same distribution of answers as the population sample.

Table 4 shows that the population sample clearly prefers heat pumps as their future heating system whereas the wood pellet sample prefers either wood pellet heating or a switch to heat pump technology.

Table 5 reports results for socio-demographic, communication and decision strategy variables. The population sample is dominated by those with a high level income and university education; conversely, the wood pellet sample is dominated by those with a medium level income and education to the high school level. All regions are represented in the population sample, while the wood pellet sample resides predominantly in the East and South of Norway. When compared to the population sample, the wood pellet sample applies the deliberation strategy more often and the repetition strategy less frequently, consistent with a relatively higher number of peers of the households from the wood pellet sample.

Table 6 shows that there is no significant difference in age between the respondents in the population sample and in the wood pellet sample. The table also shows that there is no

significant difference between the two samples regarding the perceived importance of heating system attributes.

The prerequisites for applying MLR were tested. Multicollinearity of the factors was not considered a problem because the available diagnostics (the variance inflation factor/VIF) never exceeded 2.27. As a rule of thumb, a VIF of more than 10 indicates multicollinearity; however, in a weaker model, a VIF above 2.5 may be a cause for concern (Allison, 1999). The tests shown in Table 7 were conducted to assess model fit and the model's ability to predict the dependent variable.

The logistic regression coefficients, Wald test statistics, and odds ratios for each of the variables are presented in Table 8 for the population sample and in Table 9 for the wood pellet sample.

When applying a *p* < .05 criterion of statistical significance, age, indoor air quality and decision strategy (repetition vs. social comparison) are found to be significant, whereas fuel supply security reaches marginal significance (*p* < .10) for the choice of a heat pump.

For the choice of a wood pellet stove, age and region (West vs. North) are found to be significant, while operation costs, income (medium vs. high), education (high school vs. university) reached marginal significance.

When applying a *p* < .05 criterion for statistical significance, the variables age, income (medium vs. high) and operation/maintenance work show significant effects while region

Table 4
Profiles of respondents based on the dependent variable.

Sample Future choice	Population (N=188)	Wood pellet (N=461)	Chi ² test
Electric heating	32 (17.0%)	11 (2.4%)	Chi ² = 150.616; df=2; <i>p</i> < 0.001***
Heat pump	141 (75.0%)	201 (43.6%)	
Wood pellet stove	15 (8.0%)	249 (54.0%)	

Table 5
Profiles of respondents based on categorical independent variables.

Sample Variable	Population (N=188)	Wood pellet (N=461)	Chi ² test
Household income level			Chi ² = 34.154; df=2; <i>p</i> < 0.001***
Less than NOK 250 000	18 (9.6%)	68 (14.8%)	
NOK 250 001 – NOK 550 000	65 (34.6%)	258 (56.0%)	
More than NOK 550 000	105 (55.9%)	135 (29.3%)	Chi ² = 27.025; df=2; <i>p</i> < 0.001***
Education level			
Elementary school	9 (4.8%)	79 (14.5%)	
High school	61 (32.4%)	218 (47.3%)	Chi ² = 255.798; df=4; <i>p</i> < 0.001***
University or higher	118 (62.8%)	179 (38.2%)	
Region			
East	55 (29.3%)	79 (17.1%)	Chi ² = 46.274; df=3; <i>p</i> < 0.001***
South	21 (11.2%)	313 (67.9%)	
West	53 (28.2%)	17 (3.7%)	
Mid-Norway	38 (20.2%)	37 (8.0%)	
North	21 (11.2%)	15 (3.3%)	
Decision strategy			Chi ² = 141.649; df=5; <i>p</i> < 0.001***
Repetition	47 (25.0%)	41 (8.9%)	
Deliberation	109 (58.0%)	367 (79.6%)	
Imitation	3 (1.6%)	1 (0.2%)	
Social comparison	29 (15.4%)	52 (11.3%)	Chi ² = 141.649; df=5; <i>p</i> < 0.001***
Number of peers			
0	77 (41.0%)	39 (8.5%)	
1–5	75 (39.9%)	206 (44.7%)	
6–10	23 (12.2%)	115 (24.9%)	
11–15	6 (3.2%)	37 (8.0%)	
16–20	1 (0.5%)	13 (2.8%)	
More than 20	6 (3.2%)	51 (11.1%)	

****p* < .001; ***p* < .01; **p* < .05; n.s.=not significant.

Table 6
Profiles of respondents based on the continuous independent variables.

Sample Variables	Population (N=188)		Wood pellet (N=461)		Significance test
	Mean	S.E.	Mean	S.E.	
Age	50.29	0.899	48.43	0.507	Anova $F(1.647)=3.601$; $p=0.058$; n.s.
Functional reliability ^a	4.49	0.056	4.63	0.024	Mann Whitney U test $Z=-1.388$; $p=0.165$; n.s.
Indoor air quality ^a	4.22	0.063	4.16	0.037	Mann Whitney U test $Z=-1.230$; $p=0.219$; n.s.
Investment costs ^a	3.93	0.074	3.88	0.043	Mann Whitney U test $Z=-1.089$; $p=0.276$; n.s.
Operation costs ^a	4.39	0.059	4.52	0.028	Mann Whitney U test $Z=-1.334$; $p=0.182$; n.s.
Upkeep work ^a	4.28	0.062	4.25	0.036	Mann Whitney U test $Z=-1.066$; $p=0.287$; n.s.
Fuel supply security ^a	4.41	0.065	4.55	0.031	Mann Whitney U test $Z=-1.038$; $p=0.299$; n.s.

*** $p < .001$; ** $p < .01$; * $p < .05$; n.s.=not significant.

^a 1 = not important, 5 = very important.

Table 7
Regression analysis.

Test group	Population	Wood pellet	Note
Ratio (valid cases to independent variables)	15.67	38.42	Minimum requirement:10, see Hosmer and Lemeshow (2000)20, see Peduzzi et al. (1996)
Goodness of fit:			Adequate fit corresponds to non-significance of the test.
Pearson	$Chi^2=261.593$ $df=302$; $p=0.955$	$Chi^2=668.817$ $df=832$; $p=1.000$	
Deviance	$Chi^2=178.215$ $df=302$; $p=1.000$	$Chi^2=55.079$ $df=832$; $p=1.000$	
Classification accuracy	0.755 (1.28 times better)	0.657 (1.45 times better)	Both models perform better than chance
Pseudo R-Square:			approximations to OLS R^2 , not to be interpreted as actual percentage of variance explained
Cox and Snell	0.254	0.222	
Nagelkerke	0.333	0.280	

(East vs. North) and indoor air quality reach marginal significance for the choice of electric heating.

The variables region (East vs. North), number of peers (less than 6 vs. more than 20), functional reliability, indoor air quality, fuel supply security and decision strategy (repetition vs. social comparison) were statistically significant, while region (South vs. North), number of peers (6–15 peers vs. more than 20 peers) show a marginal significance for the choice of a heat pump.

6. Discussion

The regression analysis (Table 7) indicates that the regression model is supported by the empirical data and able to perform better than chance in reproducing the observed classification of the respondents. Supported by the non-existence of multicollinearity, this indicated that the factors selected for analysis are relevant explanatory factors for the future choice of a heating system.

6.1. Determinants of possible heating system choice in the future for the population sample

This section discusses the factors that might motivate the respondents from the population sample to choose either a heat pump or a wood pellet stove, as their future heating system, and possible interventions derived from these results.

Age is statistically significant for the choice electric heating over a heat pump as well as for the choice of a wood pellet stove.

This result is also in line with the results of a Swedish pellet diffusion study conducted by Mahapatra and Gustavsson (2008) revealing that older people find it more difficult to change their behavior as they have become accustomed to their existing heating system and therefore will be less likely to install a new kind of heating system. This might be taken as an indication that younger people are more open to considering new technologies.

The region a respondent lives in shows a significant influence on the choice of heating system. Those who reside in the West of Norway are more likely than those in the North to choose electric heating rather than a wood pellet stove. This result resonates the findings of a previous study of heat pump and wood pellet adoption that was conducted after the subsidy for households was introduced in 2003 (Bjørnstad et al., 2005), showing that heat pumps were mostly adopted in western Norway, whereas wood pellet stoves were adopted in Hedmark, Oppland, and Nord-Trøndelag. This could be explained partially by the milder climate in the west coast area that makes electric heating a more practical heating option. The fact that Rogaland, alongside Oslo and Akershus, is among the regions with the highest average household income in Norway (Statistics Norway, 2009) is consistent with the findings of Nesbakken (1998) who confirmed that the higher the income, the higher the probability to choose electric heating over wood-based heating.

Indoor air quality is implied to be a disadvantage related to the use of a heat pump, because households who consider indoor air quality to be especially important are unlikely to choose this kind of heating system. The problem could be associated with the assumed dust recirculation caused by a heat pump.

Table 8
Multinomial logistic regression for future choice of a heating system in the population sample for reference category Electric Heating.

Factor	Variable	B	Wald χ^2	df	p	Odds ratio
Heat pump vs. Electric heating						
Socio-demographic	Age	-0.056	7.573	1	0.006***	0.945
	Income level (level 1 vs. 3)	0.757	0.699	1	0.403	2.133
	Income level (level 2 vs. 3)	-0.095	0.036	1	0.850	0.910
	Education level (level 1 vs. 3)	0.963	0.506	1	0.477	2.619
	Education level (level 2 vs. 3)	-0.172	0.113	1	0.736	0.842
	Region (region 1 vs. 5)	-1.297	1.245	1	0.265	0.273
	Region (region 2 vs. 5)	-1.731	1.909	1	0.167	0.177
	Region (region 3 vs. 5)	-1.629	1.944	1	0.163	0.196
	Region (region 4 vs. 5)	-1.682	1.972	1	0.160	0.186
Communication	Number of peers (0 vs. > 20)	-16.122	0.000	1	0.996	0.000
	Number of peers (1–5 vs. > 20)	-16.200	0.000	1	0.996	0.000
	Number of peers (6–10 vs. > 20)	-16.110	0.000	1	0.996	0.000
	Number of peers (11–15 vs. > 20)	0.119	0.000	1	1.000	0.000
	Number of peers (15–20 vs. > 20)	-0.115	0.000	1	1.000	0.000
Heating system attribute	Functional reliability	-0.520	1.235	1	0.266	0.595
	Indoor air quality	-0.732	4.497	1	0.034*	0.481
	Investment costs	0.439	2.110	1	0.146	1.552
	Operation costs	-0.154	0.150	1	0.699	0.858
	Upkeep work	-0.004	0.000	1	0.990	0.996
	Fuel supply security	0.574	3.799	1	0.051 ^{ms}	1.776
Decision strategy	Decision strategy (type 1 vs. 4)	-1.600	3.913	1	0.048*	0.202
	Decision strategy (type 2 vs. 4)	-0.199	0.076	1	0.783	0.820
	Decision strategy (type 3 vs. 4)	-1.571	1.001	1	0.317	0.208
Wood pellet stove vs. Electric heating						
Socio-demographic	Age	-0.122	7.570	1	0.006***	0.885
	Income level (level 1 vs. 3)	-15.474	0.000	1	0.993	0.000
	Income level (level 2 vs. 3)	1.664	3.827	1	0.050 ^{ms}	5.283
	Education level (level 1 vs. 3)	0.069	0.001	1	0.972	1.072
	Education level (level 2 vs. 3)	-2.135	3.557	1	0.059 ^{ms}	0.118
	Region (region 1 vs. 5)	-2.433	2.418	1	0.120	0.088
	Region (region 2 vs. 5)	-2.855	2.473	1	0.116	0.058
	Region (region 3 vs. 5)	-3.379	4.381	1	0.036*	0.034
	Region (region 4 vs. 5)	-1.642	1.137	1	0.286	0.194
Communication	Number of peers (0 vs. > 20)	-18.396	0.000	1	0.995	0.000
	Number of peers (1–5 vs. > 20)	-19.219	0.000	1	0.995	0.000
	Number of peers (6–10 vs. > 20)	-18.110	0.000	1	0.995	0.000
	Number of peers (11–15 vs. > 20)	-0.637	0.000	1	1.000	0.529
	Number of peers (15–20 vs. > 20)	-15.548	–	1	–	0.000
Heating system attribute	Functional reliability	-0.304	0.193	1	0.661	0.738
	Indoor air quality	-0.528	1.004	1	0.316	0.590
	Investment costs	0.314	0.490	1	0.484	1.369
	Operation costs	-1.202	3.421	1	0.064 ^{ms}	0.301
	Upkeep work	-0.333	0.332	1	0.565	0.717
	Fuel supply security	1.045	2.282	1	0.131	2.844
Decision strategy	Decision strategy (type 1 vs. 4)	-1.109	0.715	1	0.398	0.330
	Decision strategy (type 2 vs. 4)	-0.578	0.245	1	0.620	0.561
	Decision strategy (type 3 vs. 4)	-13.379	0.000	1	0.998	0.000

*** $p < .001$; ** $p < .01$; * $p < .05$; ms (marginal significance) $p < 0.1$.

Bjørnstad et al. (2005) identified dust on the filter of the inside of a heat pump as the second highest problem rated by households. Nevertheless, this problem is not necessarily due to technical shortcomings of the heat pump as it is rather part of a learning process to recognize that for an optimal performance the various components of a heat pump need regular inspection and maintenance/cleaning (Bjørnstad et al., 2005). Providing information on heat pumps and facilitating a faster learning process is important so that the problems that are raised in the early marketing stage of a new technology are not perceived as technological drawbacks.

Decision strategy is a significant factor, and respondents use repetition over social comparison to choose electric heating over a heat pump. This result suggests that they are satisfied with their existing heating system and will repeat this choice in the future.

The result suggests on the other hand, that those who are likely to choose a heat pump perform a social comparison; a reasoned and socially determined decision. One possible motivation for considering a change could be influence from active promotion of heat pumps as an alternative heating system. Households' use of the social comparison strategy could reflect their dissatisfaction with their current heating systems, and therefore they search for an alternative. Because a heat pump is considered a new technology, uncertainty is relatively high. This motivates households to compare their choices with those of other households. Applying this decision strategy, the examined households should use other households in their social network as a means to acquire information. As purchasing a new heating system involves a large investment, households are forced to elaborate on alternatives, investing more cognitive effort in the

Table 9

Multinomial logistic regression for future choice of a heating system for the wood pellet sample for reference category Wood pellet stove.

Factor	Variable	B	Wald χ^2	df	p	Odds ratio
Electric heating vs. Wood pellet stove						
Socio-demographic	Age	0.131	9.125	1	0.003***	1.140
	Income level (level 1 vs. 3)	-0.904	0.547	1	0.460	0.405
	Income level (level 2 vs. 3)	-2.873	6.302	1	0.012*	0.057
	Education level (level 1 vs. 3)	-1.892	1.148	1	0.284	0.151
	Education level (level 2 vs. 3)	0.076	0.005	1	0.942	1.078
	Region (region 1 vs. 5)	-2.999	2.765	1	0.096 ^{ms}	0.050
	Region (region 2 vs. 5)	-2.481	2.498	1	0.114	0.084
	Region (region 3 vs. 5)	0.592	0.099	1	0.753	1.807
	Region (region 4 vs. 5)	-1.163	0.246	1	0.620	0.312
Communication	Number of peers (0 vs. >20)	-14.933	0.000	1	0.989	0.000
	Number of peers (1–5 vs. >20)	-0.983	0.800	1	0.371	0.374
	Number of peers (6–10 vs. >20)	-1.627	1.667	1	0.197	0.197
	Number of peers (11–15 vs. >20)	1.527	1.301	1	0.254	4.602
	Number of peers (16–20 vs. >20)	-14.536	0.000	1	0.995	0.000
Heating System attribute	Functional reliability	0.634	0.503	1	0.478	1.885
	Indoor air quality	-0.892	2.773	1	0.096 ^{ms}	0.410
	Investment costs	-0.502	0.984	1	0.321	0.605
	Operational costs	0.072	0.012	1	0.913	1.075
	Upkeep work	-1.767	8.772	1	0.003***	0.171
	Fuel supply security	0.109	0.035	1	0.852	1.115
Decision strategy	Decision strategy (type 1 vs. 4)	-0.904	0.243	1	0.622	0.405
	Decision strategy (type 2 vs. 4)	-1.494	1.090	1	0.296	0.224
	Decision strategy (type 3 vs. 4)	-8.501	–	1	–	0.000
Heat pump vs. Wood pellet stove						
Socio-demographic	Age	-0.007	0.471	1	0.493	0.993
	Income level (level 1 vs. 3)	-0.246	0.450	1	0.502	0.782
	Income level (level 2 vs. 3)	-0.355	1.809	1	0.179	0.701
	Education level (level 1 vs. 3)	-0.181	0.262	1	0.608	0.834
	Education level (level 2 vs. 3)	-0.049	0.038	1	0.846	0.952
	Region (region 1 vs. 5)	-1.346	3.864	1	0.049*	0.260
	Region (region 2 vs. 5)	-1.106	2.988	1	0.084 ^{ms}	0.331
	Region (region 3 vs. 5)	-0.844	1.000	1	0.317	0.430
	Region (region 4 vs. 5)	-0.609	0.703	1	0.402	0.544
Communication	Number of peers (0 vs. >20)	2.129	16.506	1	0.000***	8.405
	Number of peers (1–5 vs. >20)	1.387	12.162	1	0.000***	4.001
	Number of peers (6–10 vs. >20)	0.756	3.241	1	0.072 ^{ms}	2.129
	Number of peers (11–15 vs. >20)	0.922	3.050	1	0.081 ^{ms}	2.514
	Number of peers (15–20 vs. >20)	0.305	0.167	1	0.683	1.357
Heating system attribute	Functional reliability	0.883	13.446	1	0.000***	2.418
	Indoor air quality	-0.366	6.037	1	0.014*	0.693
	Investment costs	0.084	0.377	1	0.539	1.088
	Operation costs	0.269	0.685	1	0.408	1.184
	Upkeep work	0.224	1.917	1	0.166	1.251
	Fuel supply security	-0.710	12.314	1	0.000***	0.492
Decision strategy	Decision strategy (type 1 vs. 4)	-1.165	5.620	1	0.018*	0.312
	Decision strategy (type 2 vs. 4)	-0.200	0.369	1	0.543	0.819
	Decision strategy (type 3 vs. 4)	-16.669	0.000	1	0.996	0.000

*** $p < .001$; ** $p < .01$; * $p < .05$; ms (marginal significance) $p < 0.1$.

decision process. From the interventionist perspective, changing the opinion that a household holds regarding the social appropriateness of the choice of a heat pump and thereby changing societal norms are possible interventions to motivate these households to change their behavior and replace electric heating with a heat pump. Possible means could be media campaigns including trustworthy models (e.g., celebrities with a good reputation) or providing key actors in the social networks with tailored information fitting the need of the target group.

Education has a marginally significant effect on the probability of choosing wood pellet heating. This can be taken to mean that those who have a higher education level are prepared to try an emerging and renewable technology such as the wood

pellet stove; however, education shows no significant influence on the probability of choosing a heat pump. This might be because this technology is already established in Norway. In addition, income also shows a marginally significant impact on the choice of a wood pellet system. Those with a medium-level income, unlike those with high or low income, prefer wood pellet stoves over electric heating. Scodari and Hardie (1985) showed the same outcome for wood stove acquisition in New Hampshire, US. This effect is not easy to interpret. It may be that two processes overlap: People with low income might perceive the high investment costs as an obstacle to installation of a wood pellet stove whereas people with a high income do not care about the long term savings from lower fuel prices of wood pellet heating compared to electricity.

Fuel supply security reaches a marginal significance regarding its influence on the probability of choosing a heat pump, whereas operational costs reach marginal significance concerning the choice of wood pellet heating. The more important fuel supply security is in decision making, the more likely households are to choose a heat pump rather than electric heating. This can be explained by the fact that a heat pump requires less electricity than standard electric heating units to meet the same heating demand. Those who are likely to choose a wood pellet stove rather than electric heating are those who consider operational costs to be less important. It can be inferred that the operational costs of a wood pellet stove are perceived to be higher than those of electric heating by the respondents in this sample. Operational costs and fuel supply security seem to cause concern in the population sample, suggesting that the development of the environmental heating system market can be promoted by using the low operational costs as an argument and providing reliable fuel supply.

It is worth noting that the number of households that choose wood pellet heating is quite small (only 8% of the population sample's respondents). Most of them prefer heat pumps, followed by electric heating. This means that the results for wood pellet heating must be interpreted with care. This also conveys low observability of wood pellet heating in this sample, meaning that wood pellet heating might not be recognized by most households due to its small market share. This is also the case for solar energy technology (Labay and Kinnear, 1981). To increase the observability of wood pellet stoves, existing networks of wood pellet users must be supported. As wood pellet users (see Table 5) communicate with other households more than others do, they may serve as nodes in their social networks or are at least part of a well-functioning social network. As such this group could offer advice to potential consumers and create awareness when they are at the point of making a real investment decision. This would ensure that the pellet option is at least considered when deciding about the future heating system. This network forms the vehicle through which the advantages of wood pellet heating are communicated. Studies indicated that communication with adopters could increase the probability of adoption (Frambach, 1993; Midgley et al., 1992). It is therefore essential that policy makers have a thorough understanding of those households that are in influential positions.

6.2. Determinants of possible heating system choice in the future for the wood pellet sample

This section introduces the influential factors that explain when wood pellet adopters continue to keep wood pellet heating as their main heating system or switch to either electric heating or a heat pump in the future. The discussion also includes possible strategies that could be applied to increase the uptake of wood pellet stoves.

Age has a significant influence on the choice of electric heating, but it is insignificant concerning the choice of a heat pump. Those who currently use wood pellet heating are more likely to choose electric heating rather than continuing to use wood pellet stoves as they grow older. This is consistent with the results that electric heating is preferred by older people. This could be due to the fact that it requires less work compared to the wood pellet stove, e.g. loading/unloading pellets, cleaning the stove, etc.

Income once again shows a significant influence on the choice of electric heating. Those with a high income prefer electric heating, whereas those with a medium income prefer wood pellet stoves. The same result has also been shown for the population sample discussed above.

Region has a significant impact on the choice of a heat pump and a marginally significant impact on the choice of electric heating. Those who reside in the East and those who live in the South are more likely than those who live in the North to choose wood pellet stoves over electric heating or a heat pump. This could be due to the fact that the biggest wood pellet producer in Norway is located in Hedmark. The short distance between producer and consumers results in an easy and reliable access to wood pellets for households in the East and in the South. As a main reason of the electric heating lock-in is easy access and fuel price fluctuation was proven to be a significant influence for the shifts of heating system (Brottemsmo, 1994), these imply that the fuel supply plays an important role to heating system adoption in Norway.

The results suggest that those who are most likely to continue choosing the wood pellet stove apply the decision process of repetition rather than social comparison. This behavior reflects their satisfaction with the wood pellet stove. Factors that contribute to the satisfaction and dissatisfaction with wood pellet stoves merit further study to identify the areas for improvement. Alternatively, another possible strategy to promote wood pellet stoves would be to give positive reinforcement/rewards to those who repeat their choice. Rewards could be quantity discounts for the purchase of wood pellets.

As the same result can also be found in the population sample, it can be generalized that the decision about the acquisition of a heat pump is dominated by a strategy of social comparison. Accordingly, the purchase of a heat pump is influenced by the market share of this technology. This finding is in line with the results of a previous study of heat pump adoption confirming that recommendation from other users is the most important motivation to install a heat pump (Bjørnstad et al., 2005). Social influence is strong in the decision for a heat pump but this does not imply irrationality in decision making. The strategy of social comparison most likely supports a rational decision, but the information needed for decision making is acquired from the social network instead of other sources. The consistent result of social comparisons dominating the decision for a heat pump gives an indication that this aspect of a household's decision making process should not be ignored by policy makers.

Contrary to heat pump market, there are not yet a sufficient number of people using wood pellet heating to form a social reference group. Once a critical number of people use a product is reached, market behavior often changes and other factors drive the adoption process, a change that is called a 'chasm' in the diffusion literature (Moore, 1999). The market for wood pellets seems still to be in its early stage before this chasm, which makes interventions such as continued subsidy necessary to achieve a critical mass of wood pellet users that can drive the market as opinion leaders in a later stage.

It is worth noting that about 43% of current wood pellet users prefer heat pumps as their main heating system in the future. Only about half of the wood pellet users anticipate continuing with the choice of wood pellet heating. The result shows that those who are dissatisfied with their wood pellet stove are likely to compare their existing heating system with that preferred by most members of their social network (which would usually be a heat pump). The dissatisfaction could be due to bad experience with the wood pellet stove or with aging. As the results show that those who perceived functional reliability more important are unlikely to continue using wood pellet heating, improving functional reliability should be a priority.

Even though investment and operational cost as heating system characteristics fail to be significant aspects of the decisional process, there is an interesting finding showing that those with high level income prefer the use of electric heating

although the investment in wood pellet stoves should be affordable. This raises the question why people who are able to afford wood pellet stoves prefer to choose electric heating. One possible explanation could be that electric heating appears to be the most convenient heating source as almost no maintenance work is required. Some households, for example older people, could perceive the necessary work related to the use of a wood pellet stove too difficult because of physical limitations. Another possible explanation is that these households value their time and time spent on maintaining and operating a wood pellet stove might be considered wasted. Finally, people with high incomes could be less affected by fluctuating electricity prices on the market and therefore do not perceive this advantage of wood pellet stoves as much as people with less income.

The results indicate that those who recommended a heating system to more than 20 peers are most likely to keep on using wood pellet heating. This means that those who plan to continue using wood pellet heating in the future seem to show more opinion leadership than those who want to change to heat pumps. However, it has to be repeated that recommendation against a heating system was not recorded in this study, so it might be possible that wood pellet users dissatisfied with wood pellet heating have opinion leadership in the negative direction. Recommendation behavior reflects people's satisfaction/dissatisfaction with their current heating system, i.e. households will not recommend a heating system if they are not satisfied with it. This implies that those who give recommendation to more than 20 peers are satisfied with using a wood pellet stove. The fact that wood pellet heating adoption is low indicates that recommendation by adopters is not enough to enhance the adoption rate. The relative advantages of wood pellet stoves should be made more visible before choosing a communication based strategy to enhance wood pellet adoption. Once the technology-related factors of wood pellet heating are perceived as advantageous, the communication behavior of wood pellet users might contribute to further adoption. The improvement of the subjective evaluation of the system attributes of wood pellet stoves should be the main concern for increasing wood pellet adoption.

Interestingly, the importance of investment cost was found to be statistically insignificant in both the population sample and the wood pellet sample. However, including income as a variable has reduced the explanatory power of investment costs because income and the importance of investment costs are related to each other. Eliminating income from the regression equation to test this assumption resulted in a significant impact of investment cost.

6.3. Limitations

Although this study adds the dimension of decision strategy to the baseline models for selection of a heating system, some limitations should be highlighted. Firstly, the dependent variable has limitations. The question designed for the dependent variable was intended to ask for only one main/primary heating system. However, because Norwegian households usually have more than one type of heating, it might be possible that they are unclear about which is their main heating system. Less than 4% of all respondents chose two heating systems when answering the question. They were included in the analysis by selecting one of their chosen heating systems. Secondly, the study only modeled anticipated choice and not real choice as people may eventually choose different heating systems than they intend to. A retrospective study of heating choice or a longitudinal study would have addressed this problem. Thirdly, the communication factor only included the number of people to whom the

household has recommended a heating system, but not against. Adding another variable to cover this would have been insightful regarding the aspects of negative peer communication on product diffusion. Fourthly, the different sizes of the samples are another problem as it is easier to get significant results in a larger sample. The extremely small group of wood pellet users preferring electric heating as their future heating system and households in the population sample preferring wood pellet stoves made the respective results rather weak compared to the others. Fifthly, this study is based only on quantitative data, complementing the study by qualitative interviews would gain insight into the more complex processes of decision making that a simple regression analysis is not able to reveal. Sixthly, the sample drawn from the population registry was not stratified because there was no access to stratification variables. This might have led to a sampling bias in the population sample. Seventhly, people choosing imitation as their decision strategy should not evaluate the importance of heating system attributes at all. Not providing a "do not know" option in those questions forced them to give an answer that probably was not relevant for them. However, this group is small in both samples. Only 1.6% in the population sample and 0.2% in the wood pellet sample were using the imitation strategy. And finally, this study has not researched the optimal balance of heating options relevant for Norway, i.e. the authors do not hold a bias toward 100% adoption of wood pellet stoves over other type of heating systems. Issues of sustainability and forest management would need to be taken into consideration before making any conclusion on this matter.

The results of this study are relevant to Norway and should be interpreted within the context of the specific market situation. However, the framework of proposed influential factors can be applied and tested empirically in different countries. The significance of factors might vary between different countries due to country-specific market situations. While socio-demographic factors, household communication, and heating system attributes are not unprecedented in heating system adoption studies, the decision strategy applied by the household is a new addition to this model of heating system choice. The results clearly show that decision strategies play an important role in the choice of a heating system in Norwegian households, and therefore, they merit further investigation. As this study focused on electric heating, heat pump and wood pellet stove, other types of heating system may require different heating system attributes to be analyzed. However, most heating system attributes used in this study should be relevant for all types of heating systems.

7. Conclusion

This paper has met the objective of identifying factors that influence the heating system purchasing decision made in Norwegian households. To summarize, the results have important implications for the diffusion of sustainable heating systems in Norway. Different policies are needed for different groups of households. For example, households consisting of younger people should be prioritized in programs promoting heating systems based on new technologies. Region-related constraints also have to be considered as they may limit the heating options available. Although only marginally significant, fuel supply security and operational cost seem to be two relevant factors in the decision for sustainable heating systems. This implies that sustainable heating systems should be able to offer reliable fuel supply and low operational cost to compete with electric heating and focus their marketing strategy on these aspects. Financial support seems still necessary due to low market share of wood pellet heating. Additional research is needed to determine the

appropriate conditions to increase the number of wood pellet users sustainably.

Acknowledgment

Financial support provided by Norwegian University of Science and Technology (NTNU), Norway, is gratefully acknowledged. The authors wish to thank the anonymous reviewers whose insightful suggestions greatly improved an earlier version of this paper, and Cecilia Haskins for her diligent editing services.

References

- Allison, P.D., 1999. Logistic Regression Using the SAS System: Theory and Application. SAS Institute Inc. and John Wiley and Sons Inc.
- Bjørnstad, E., Grande, J., Sand, R., Wendelborg, C., 2005. Evaluering av tilskuddordninger til varmepumper, pelletskaminer og styringssystemer, Nord Trøndelags-forskning, last retrieved September 2009, http://generator.firma nett.no/t/tforsk/doc/Ra_2_05.pdf, in Norwegian.
- Brottemsmo, J., 1994. Residential heating choice and energy demand: Norwegian responses in 1980 and 1990, Working Paper No. 118/1993, Center of Research in Economics and Business Administration.
- Brown, S.A., Venkatesh, V., 2005. Model of adoption of technology in households: a baseline model test and extension incorporating household life cycle. *MIS Quarterly* 29 (3), 399–426.
- Christiansen, A.C., 2002. New renewable energy developments and climate change issue: a case study of Norwegian politics. *Energy Policy* 30, 235–243.
- Frambach, R.T., 1993. An integrated model of organizational adoption and diffusion of innovations. *European Journal of Marketing* 27 (5), 22–41.
- Gilly, M.C., Graham, J.L., Wolfenbarger, M.F., Yale, L.J., 1998. A dyadic study of interpersonal information search. *Journal of the Academy of Marketing Science* 26, 83–100.
- Hosmer, D.W., Lemeshow, S., 2000. Applied logistics regression, Wiley series in probability and statistics 2nd ed. John Wiley and Sons Inc., Canada.
- Innstilling til Stortinget fra energi-og miljøkomiteen nr. 133, 2002–2003, last retrieved in September 2009, <http://www.stortinget.no/Global/pdf/Innstilling/Stortinget/2002-2003/inns-200203-133.pdf>.
- Jager, W., 2000. Modeling consumer behavior, Doctoral thesis, Rijksuniversiteit Groningen, the Netherlands.
- Jager, W., 2006. Stimulating the diffusion of photovoltaic systems: a behavioral perspective. *Energy Policy* 34, 1935–1943.
- Janssen, M.A., Jager, W., 2002. Stimulating diffusion of green products: co-evolution between firms and consumers. *Journal of Evolutionary Economics* 12, 283–306.
- Kasanen, P., Lakshmanan, T.R., 1989. Residential heating choices of Finnish household. *Economic Geography* 65 (2), 130–145.
- Labay, D.G., Kinnear, T.C., 1981. Exploring the consumer decision process in the adoption of solar energy systems. *Journal of Consumer Research* 8, 271–278.
- Lackman, C., Lanasa, J.M., 1993. Family decision-making theory: an overview and assessment. *Psychology and Marketing* 10 (2), 81.
- Lark, R., 1989. A polychotomous probit measure and analysis of inflationary expectations. *Journal of Macroeconomics* 2 (2), 269–280.
- Larsen, B.M., Nesbakken, R., 2005. Formålsfordeling av husholdningenes elektrisitetsforbruk i 1990 og 2001. Økonomiske analyse 4/2005, last retrieved September 2009, <http://www.ssb.no/emner/08/05/10/oa/200504/nesbakken.pdf>.
- Lindhjem, H., Navrud, S., 2009. Asking for individual or household willingness to pay for environmental goods? Implications for aggregate welfare measures. *Environmental and Resource Economics* 43 (1), 11–29.
- Lohr, S.L., 2009. Sampling: Design and Analysis 2nd Edition Brooks/Cole, Boston, MA.
- Mahapatra, K., Gustavsson, L., 2008. An adopter-centric approach to analyze the diffusion patterns of innovative residential heating systems in Sweden. *Energy Policy* 36 (2), 577–590.
- Markusson, N., Monsen, K., Russel, S., 2009. Promotion of efficient heat pumps for heating (ProHeatPump), EIE/06/072/S12.444283, Work Package 4: Policy context and measures, The University of Edinburgh, last retrieved in June 2009, <http://www.proheatpump.eu/Downloads/Deliverables/Proheatpump%20D5%20Report%20Norway.pdf>.
- Midgley, D.F., Morrison, P.D., Roberts, J.H., 1992. The effect of network structure in industrial diffusion processes. *Research Policy* 21 (6), 533–552.
- Moore, G.A., 1999. Crossing The Chasm Revised edition Harper Business Essentials, US.
- Nesbakken, R., 1998. Residential energy consumption for space heating in Norwegian households: a discrete-continuous choice approach, Discussion Papers no. 231, Research Department, Statistics Norway.
- Nesbakken, R., Strøm, S., 1994. The choice of space heating system and energy consumption in Norwegian household, Statistics Norway.
- Norwegian Strategy Group, 2006. Lavutslippstvalget, last retrieved in June 2009, <http://www.lavutslipp.no/>.
- Peduzzi, P., Concato, J., Kemper, E., Holford, T.R., Feinstein, A.R., 1996. Simulation study of the number of events per variable in logistic regression analysis. *Journal of Clinical Epidemiology* 49, 1373–1379.
- Peksa-Blanchard, M., Dolzan, P., Grassi, A., Heinimo, J., Junginger, M., Ranta, T., Walter, A., 2007. Global wood pellets markets and industry: policy drivers, market status and raw material potential, IEA Bioenergy Task, 2007, last retrieved on June 2009, <http://www.city.north-bay.on.ca/business/presentations/woodPellets/Global%20wood%20pellets%20market%20and%20industry%20Nov%2007%20report.pdf>.
- REMODECE Project, 2006. Last retrieved September 2009, <http://www.sintef.net/Olje-og-energi/SINTEF-Energiforskning-AS/Prosjektarbeid/USELOAD-/REMODECE/>.
- Rogers, E.M., 2003. Diffusion of Innovations 5th ed. Free Press, New York.
- Schwarz, N., Ernst, A., 2009. Agent-based modeling of the diffusion of environmental innovations – an empirical approach. *Technological Forecasting & Social Change* 76, 497–511.
- Schwoon, M., 2006. Simulating the adoption of fuel cell vehicles. *Journal of Evolutionary Economics* 16 (4), 435–472.
- Scodari, P.F., Hardie, I.W., 1985. Heating costs and household wood stove acquisition: a discrete choice demand model, *Northeastern Journal of Agricultural and Resource Economics*, 14(1), last retrieved in October 2007, <http://purl.umn.edu/28935>.
- Statistics Norway, 2006. Last retrieved in January 2008, <http://www.ssb.no/emner/01/03/10/husenergi/>.
- Statistics Norway, 2009. Last retrieved in December 2009, <http://www.ssb.no/emner/05/01/inntgeo/tab-2009-05-13-01.html>.
- Tapaninen, A., Seppänen, M., Mäkinen, S., 2009. Characteristics of innovation: a customer-centric view of barriers to the adoption of a renewable energy system. *International Journal of Agile Systems and Management* 4 (1/2), 98–113.

**Modeling Adoption and Diffusion of Heating System in Norway:
Coupling Agent-Based Modeling with Empirical Research**

Bertha Maya Sopha

*Industrial Ecology Programme and Department of Energy and Process Engineering
Norwegian University of Science and Technology
N-7491 Trondheim, Norway*

Christian A. Klöckner

*Department of Psychology, Section for Risk Psychology, Environment and Safety
(RIPENSA)
Norwegian University of Science and Technology
N-7491 Trondheim, Norway*

Edgar G. Hertwich

*Industrial Ecology Programme and Department of Energy and Process Engineering
Norwegian University of Science and Technology
N-7491 Trondheim, Norway*

Submitted for publication 2010

Modelling Heating System Adoption and Diffusion in Norway: Coupling Agent-Based Modelling with Empirical Research

Bertha Maya Sopha^{1*}, Christian A. Klöckner², Edgar G. Hertwich¹

¹ Industrial Ecology Programme and Department of Energy and Process Engineering, Norwegian University of Science and Technology, NO-7491 Trondheim, Norway

² Department of Psychology, Section for Risk Psychology, Environment and Safety (RIPENSA), Norwegian University of Science and Technology, NO-7491 Trondheim, Norway

* Corresponding author: bertha.sopha@ntnu.no; bertha_mamun@yahoo.com

Models can support policy designers to examine interventions in favor of environmentally friendly technology. Since adoption and diffusion of a technology is not only related to the technology, policy designers must also consider human behavior in the policy assessment and development. The present paper introduces a methodological proposal for modelling heating system adoption and diffusion from the end-user perspective. Based on theoretical considerations and empirical findings, a conceptual model for adoption decisions is proposed. The adoption-decision model capturing the heterogeneity of adoption decision processes has been derived by combining insights from the diffusion of innovation theory, the theory of planned behavior, the utility theory, and the meta-theory of consumer decision strategies. We have embedded this adoption-decision model in an agent-based simulation model and conducted an empirical survey to produce statistically representative quantitative data for the model. A case of heating system adoption and diffusion in Norway is introduced to illustrate the application of the proposed methodology. The theoretically-based, empirically-founded, agent-based model is able to reproduce the general patterns of heating system diffusion in Norway.

Keywords: *methodological proposal, agent-based modelling, empirical survey, heating system*

1. Introduction

Studies on adoption and diffusion modelling (e.g., Panebianco and Pahl-Wostl, 2006) have drawn attention to that the adoption and diffusion of technology are not only related to features of the technology, but are also related to the human factor. Given the fact that individual behavior influences consumption and hence impacts environment (Stern, 2005), it is not enough to consider only the existence and cost-competitiveness of various sustainable technologies. The behavior of consumers, including the role of social and psychological factors needs to be embraced when designing a policy favoring a higher diffusion of sustainable technology.

The present paper therefore aims at proposing a methodological approach to develop a simulation using agent-based modelling (ABM) with the agent decision-making model derived from empirical research. Taking up residential heating system adoption and diffusion in Norway as a case application, the developed model is designed to identify potential interventions to increase adoption and diffusion of sustainable heating system among Norwegian households.

2. Methodological Proposal: Coupling Agent-Based Modelling with Empirical Research

Adoption and diffusion of a technology have been widely studied from different perspectives. Social and behavioral research, for example, has contributed to the identification of essential factors influencing the adoption of technology. The statistical techniques that have been widely used in this type of research have, however, common limitations: The static and aggregated handling of the techniques conceals much of the detail of individual characteristics. Moreover, the techniques are unable to adequately represent social networks which are known to significantly influence adoption decisions (e.g., Valente, 1996). On the other hand, agent-based modelling, which allows the representation of the agents' heterogeneity and of social networks, has mostly been applied as an experimentation tool to demonstrate diffusion patterns resulting from simple rules followed by different artificial agents in the system (e.g., Janssen and Jager, 2002; Andrews and DeVault, 2009). Thus, a considerable gap between those two scientific approaches is evident: The empirical research

derives detailed findings regarding the adoption of a specific technology but lacks the correct representation of complex social processes in networks of agents while simulation research employs abstract models which mostly do not refer to any specific technology and setting. The present paper also contributes to filling a methodological gap by coupling ABM with empirical research, as proposed by Janssen and Ostrom (2006). Although combination of empirical and simulation methods have been applied in other domains (e.g., Smajgl [2010], Naivinit et al. [2010]), only very few implementations can be found within the context of adoption and diffusion of sustainable technology (e.g., Schwarz and Ernst, 2009).

We therefore propose a methodological approach coupling empirical research and computational modelling of technology adoption and diffusion comprising of four steps: The first step is a literature review on consumer behavior related to adoption of this particular technology. Second, based on the theoretical considerations and empirical findings from the literature, a conceptual model is constructed. Third, an empirical survey which both tests the conceptual model and produces input parameters for the simulation is carried out. The first three steps allow a more representative decision-making model of households in the sense that it captures technology-related factors and psychological factors, and follows empirically grounded behavioral principles. The fourth step is the implementation and simulation in an ABM. A case study of heating system adoption and diffusion in Norway is offered as an illustration of the application of this methodological proposal.

3. Theoretical Framework for Modelling Adoption Decision

This section addresses how to model the decision making of agents in an ABM, aiming at modelling the decision process in a manner that is grounded in theoretical and empirical decision research. This section, which relates to the first step of the methodological proposal, aims to provide a theoretical framework to derive rules for behavior of consumers regarding the adoption of a technology that will later be used in the simulation. Four different theories from existing literature are implemented into this framework and discussed in the following sections, i.e. diffusion of

innovation (Dol) theory (Rogers, 1962), theory of planned behavior (TPB) (Ajzen, 1991), utility theory (Fishburn, 1970), and meta-theory of consumer decision strategies (Jager, 2000). Because those theories have been widely applied in different domains, we assume that these theories are relevant to all kind of behaviors and thus could be used as a starting point to model adoption decisions in other technology applications.

3.1. Diffusion of Innovation Theory

Diffusion of Innovation (Dol) was introduced by Rogers (1962) to explain why and at what rate innovation spreads. Rogers (2003) specified the following contributing factors to the adoption and further diffusion: characteristics of consumers (i.e., socio-demographic factors, personality), technology attributes, communication channel, and characteristics of decision-making process.

With respect to personality, Rogers (2003) recognizes that consumers differ when it comes to their attitudes toward innovation characteristics. Furthermore, according to Reusswig et al. (2008), consumers are heterogeneous in terms of their lifestyle which will then influence consumption. In this study, we grouped consumers based on income level and value orientation to approximate the influence of lifestyle on attitudes toward a technology. In studies applying diffusion of innovation theory, innovation attributes were able to explain approximately 49-87% of the variance of adoption (Rogers, 2003). Because of this obvious importance, these attributes are included in the model. Supporting the Dol with respect to the influence of social communication on adoption, Valente (1996) demonstrated empirically the effect of media and opinion leaders on the diffusion process. For that reason, social interaction among consumers in decision-making is also taken into account in the framework model.

Consequently, the study distinguishes consumers with respect to geographical location, consumer group, social influence in decision making, and decision strategy employed; the latter is described in detail in sub-section 3.4.

Dol has been widely used to investigate role of innovation characteristics in technology acceptance, communication effect on diffusion, determinants of technology adoption, and so forth.

Despite its practical capability to explain empirical findings on technology adoption and diffusion, this theory has a limitation when it comes to adoption processes which are constrained by situational factors such as a lack of resources and access to technologies (Wilson and Dowlatabadi, 2007). In our framework model, we use consumer characteristics, technological attributes and social interaction as proposed by the diffusion of innovation theory, but supplement them with variables included in psychological model of household decision-making as described in section 3.2.

3.2. Theory of Planned Behavior

The theory of planned behavior (TPB) was first proposed by Ajzen (1991), who described adoption behavior as predicted by three psychological factors, i.e., attitudes, perceived behavior control (PBC) and subjective norms. This theory has been widely applied as a model for identifying psychological factors that underlie decisions, e.g., in the case of transport choice (Bamberg et al. 2003) and recycling (Tonglet et al., 2004). Klöckner and Blöbaum (2010) extended the theory of planned behavior with a selection of psychological constructs from other theories, most importantly personal norms and habits. Klöckner and Blöbaum (2010) indicated whereas habits are commonly considered not important for a decision made every 10 to 20 years, personal norms may be relevant. This study thus implements personal norms which represent a consumer's perceived moral responsibility to use an environmentally friendly heating system, instead of subjective norms as proposed by Ajzen (1991).

Nevertheless, the psychological model only addresses the intrapersonal decision mechanisms. To alleviate this limitation, a model combining the theory of planned behavior and innovation attributes has been introduced and applied extensively in information technology studies (Jeyaraj et al., 2006). The implementation of TPB in the study is used as a blueprint for connecting the perceived attributes of heating systems as described in the diffusion of innovation theory and individual intention mediated by psychological factors. We then refer intention formation as internal factor. In order to incorporate external factor in the model, i.e. social influence in decision-making, utility theory is applied and its implementation is described in section 3.3.

3.3. Utility Theory

One of the economic behavioral principles is that people act rationally, meaning that they seek to maximize utility and choose a product that gives the highest utility. Thus, a decision outcome that results in a higher utility will be consistently preferred to an alternative outcome with a lower one (Wilson and Dowlatabadi, 2007). As used in economics, utility theory acts as a framework for decisions that weight the utility of an outcome X_i by its probability P_i , denoted as $\sum_i P_i u(X_i)$, where u is a function that measures the value of an outcome.

This study implements utility theory to frame decisions by weighting the utility of internal factor (derived from section 3.2) and the utility of external factor, i.e. social influence. The importance of social influence in decision-making is resonated in the diffusion of innovation theory which specifically identifies that decisions are not only influenced by personal needs, but also by social requirements. For instance, buying a car is not only done to fulfill a need for transportation, but also to obtain social identity and status. Empirical evidence provided by Jager (2006) confirmed that the social needs for belonging and participation were important in photovoltaic purchasing. Moreover, utility theory to weigh personal and social needs has been applied in other simulation studies (Janssen and Jager, 2002; Schwoon, 2006; Schwarz and Ernst, 2009).

3.4. Meta Theory of Consumer Decision Strategy

According to the meta-theory of consumer decision strategies (Jager, 2000), consumers may apply different decision strategies depending on their level of satisfaction with a product and the degree of uncertainty connected to a decision. This theory categorizes four decision strategies: 1) Repetition: consumers will habitually consume a product that they have previously consumed, 2) Deliberation: consumers will evaluate all possible alternatives and consume the product with the highest utility, 3) Imitation: consumers will choose the product that most of their social network consumes, and 4) Social Comparison: consumers will conduct a social comparison by comparing the utility of the product previously consumed with the product that most of their peers, selecting the product yielding the highest utility. Only the deliberation strategy is compatible with utility theory,

whereas repetition and imitation are clearly not. Social comparison represents a heuristically simplified utility maximizing with a pre-selection reduction of the choice set to just two alternatives. This meta-theoretical approach, developed within social psychology, was based on a comprehensive study of human behavior and specifically designed for simulating consumer choice. This theory has therefore been demonstrated in simulation study of behavioral choice, i.e., Jansen and Jager (2000).

The reason we are applying this theory is that it offers the opportunity to model an inhomogeneous use of decision strategies among agents. It allows us to consider deliberation as well as the effect of repetition and imitation, i.e. inertia and social influence, because individuals do not always make consistently rational decisions, but instead use a wide range of rules or heuristics to reduce cognitive processing.

4. Empirical Data Acquisition

The aims of the empirical data acquisition are both to test conceptual model and to provide input parameters for the simulation. The empirical data for the simulation was collected through a survey which was specifically designed in order to produce quantitative data statistically representative for the population under study. One thousand five hundreds questionnaires were mailed to Norwegian households in the last quarter of 2008 (Sopha et al., 2010a). The final response rate after a reminder sent was 19.4% (291 responses). Due to missing values in key variables, the final analysis for this study was based on a sample of 270 households. Statistical analysis confirmed that the sample was representative for Norwegian households with respect to age and regional distribution.

The questionnaire consists of questions related to household such as socio-demographic, number of peers that are communicated with about a heating system, degree of social influence in decision making, decision strategy, as well as, psychological factors including intention, attitudes, perceived behavioral control, personal norms, perceived attributes of different types of heating technologies, and basic values of materialism vs. post materialism (Inglehart and Abrahamson, 1999).

The empirical survey did however not collect information on the structure of the social network. Therefore, a sensitivity analysis of differently structured social network has been conducted (Sopha et al., 2010b).

5. Conceptual Model

This section of the paper describes the construction of a conceptual model which was derived from theoretical insights and empirical findings and parameterized with the empirical survey. The focus of the conceptual model is on households' decision making about investing into a heating system technology. The conceptual model consists of model components which will be implemented in agent-based model as described below.

5.1. Agents

The study considers a household as a decision-making unit. Thus, one agent in this model represents one household. Household agents are constructed to be heterogeneous with respect to some attributes discussed in section 3.1 and shown in detail in Table 1. Geographic location of households is represented by a spatial grid based on a geographical representation of Norway. The spatial representation of households should be considered in household models for two reasons. First, a household's social interaction is determined to a large extent by the location of the household. Second, Sopha et al. (2010c) found that location has a significant impact on the heating system choice of a heat pump versus wood pellet heating. Whether regional barriers exist is of interest, thereby meriting further analysis.

With respect to household group, a cluster analysis based on the variables income and basic value orientation resulted in three groups, whereby a significant difference among clusters with respect to income level and basic values was identified (see Fig. 1). Household Group 1 represents households with a low/medium income, but post-materialistic values; Household Group 2 represents those with a medium/high income with a medium level of materialism, whereas Household Group 3 represents those with a low/medium income and materialistic values. Household group is a crucial

part of the model as it provides an indirect influence to the relation of perceived heating system attributes to attitudes.

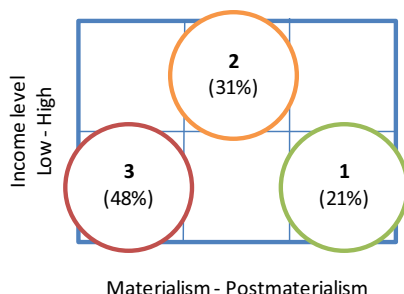

Figure 1. Household groups based on cluster analysis

Table 1. Households’ specific attributes

Households’ specific attributes	Initialization and Allowable Ranges
Geographical location	Real geographical location presented in a grid
Household group	Each household is assigned to one of the three groups acquired from the survey at the start of simulation 1: Low-medium income and post-materialism 2: Medium-high income and medium materialism 3: Low-medium income and materialism
Decision strategy	Each household select one of the decision strategies randomly each time-step with the probabilities acquired from empirical survey: 1 = Repetition (23.5%) 2 = Deliberation (59.1%) 3 = Imitation (2.1%) 4 = Social comparison (15.3%)
Degree of social influence when making decision	Determined at the start of simulation Range of 0 – 1 with an interval of 0.1
Number of peers communicated with about heating system	Determined at the start of simulation Range of 0 – 16

5.2. Technology Attributes

Three competing heating systems are examined: direct electric heating (the standard technology), individual wood pellet stove and air-to-air heat pump. The study utilizes heating system attributes identified by Mahapatra and Gustavsson (2008) which are shown in Table 2. These attributes are user-settable parameters (exogenous variables) in the model. The initial values of these parameters are however obtained from the survey (see Table 2). Policy designers can use the

initial values as references and modify them to see the effect resulting from this change. The model allows policy designers to intervene in different parts of the system. Since the model incorporates personal norms, policy designers are also able to design a variety of programs ranging from soft interventions (e.g., influencing household beliefs through promotion) to regulation (fixed fuel prices or installation subsidies) or technical intervention (functional reliability development or automation).

Table 2. Mean values of the subjective perception on heating system attributes derived from the survey

Heating System Attributes	Electric Heating	Heat Pump	Wood Pellet Heating
Fuel Price Stability ^a	0.33	0.49	0.45
Indoor Air Quality ^b	0.52	0.67	0.57
Functional Reliability ^c	0.85	0.72	0.61
Total Cost (investment and operation costs) ^d	0.48	0.43	0.56
Required Work ^e	0.11	0.32	0.57

Note: 1) data represent mean values rated by households using a 7-point Likert scale, which was then re-coded into a numeric scale from 0 (minimum) to 1 (maximum). 2) The higher value, ^athe more stable, ^bthe better quality, ^cthe more reliable, ^dthe higher cost, ^ethe more required work

5.3. Social Interaction

Households reside in a social network in which they communicate with and/or observe the behavior of other consumers. The implementation of social interaction in this study is based on two factors; number of peers a household communicates with about heating systems as a representation of their communication habits, and the structure of social network. The number of peers is obtained from the survey and is a household-specific (see Table 1). Midgley et al. (1991) were able to document a substantial effect of the modeled network structure on the diffusion process. The social network applied for this study is the small-world network based on the sensitivity analysis of different structures of social networks on the diffusion rate (Sopha et al., 2010b).

5.4. Adoption-Decision Model

In this study, we explicitly model differences in consumer decision-making. Diffusion of innovation (Rogers, 2003), theory of planned behavior (Ajzen, 1991), utility theory (Fishburn, 1970) and meta-theory of decision strategy (Jager, 2000) are integrated into a household's adoption-decision model. Such an integrated model is needed for three reasons. First, each decision theory is

not universally applicable, but has particular behavioral niches. For instance, the diffusion of innovation theory (Rogers, 2003) centers on technology attributes influencing adoption, while the theory of planned behavior reveals that not only attitudes, but subjective norms and perceived behavioral control are also predictors of intention, which then predicts adoption (Ajzen, 1991). The diffusion of innovation theory and the theory of planned behavior complement each other, and are therefore combined. Second, each decision theory has a different focus, individual versus social. For example, a psychological model which is concerned with individual aspects needs to be combined with social interactions to include social influence in decision-making. Third, since research and interventions should be based on decision models that match the behavior in question, it is necessary to construct a model which captures the heterogeneity of decision-making strategies that households may employ as representatively as possible, while still being able to be formalized mathematically.

The integrated decision model which we like to refer to as the adoption-decision model is displayed in Fig. 2. The meta-theory of consumer decision strategy is applied to represent which decision strategy is performed by households. Household agents decide upon a heating system following the adoption-decision model. Depending on the employed decision strategy, household agents follow various decision-making processes specified in the adoption-decision model. Each decision strategy follows its own line of decision processing as shown in Fig. 2. Those who apply repetition adopt the same heating system as previously done without any other cognitive process involved; those who apply imitation adopt the heating system primarily used by their peers (neighboring households and random-selected households); those who deliberate apply utility maximization to identify the system that suits best. Within this utility maximization, variables described in the theory of planned behavior and in diffusion of innovation are implemented to represent the mechanisms of intention formation and attribute selection and evaluation.

An individual intention is formed based on attitudes, personal norms and PBC. The perceived heating system attributes are explanatory variables, whereas household group is a moderator, of the

relation between heating system attributes and attitudes. Perceived behavioral control which reflects the consideration of past experiences and anticipated barriers (Ajzen, 1991) is predicted by perceived heating system attributes as these perceptions could enhance or reduce the perceived ability to implement a heating technology. To incorporate social influence within a decision, the utility function combines individual intention and social interaction to take into account both internal and external factors in household decisions. A utility-based model seeks to describe choices, and the choice is made based on its highest utility. The utility calculation is based on the adoption-decision model described further by the following equations.

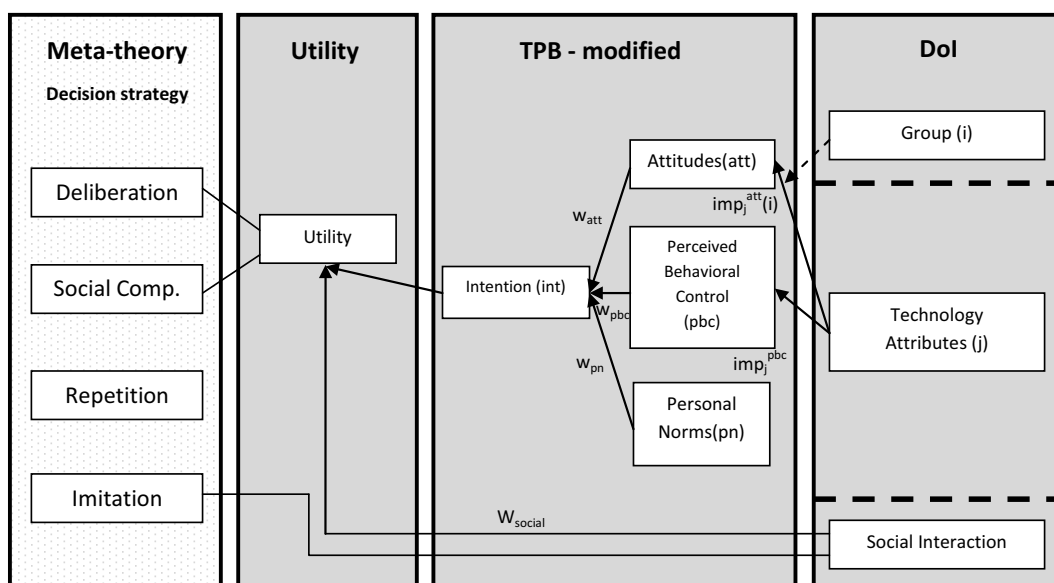

Figure 2. Adoption-Decision Model

$$att = \sum_j imp_j^{att}(i) * value_j \quad (1)$$

$$pbc = \sum_j imp_j^{pbc} * value_j \quad (2)$$

$$int = w_{att} * att + w_{pbc} * pbc + w_{pn} * pn \quad (3)$$

$$\%peers = \text{peers with technology type in question} / \text{total peers} \quad (4)$$

$$utility = int * (1 - w_{social}(k)) + \%peers * w_{social}(k) \quad (5)$$

where:

<i>i</i>	is household group
<i>j</i>	is technology attribute
<i>k</i>	is a household
<i>att</i>	is attitude toward a technology
$imp_j^{att(i)}$	is the importance of technology attribute <i>j</i> of group <i>i</i> to attitude formation
$value_j$	is perceived technology attribute <i>j</i>
<i>pbc</i>	is perceived behavioral control of a technology
imp_j^{pbc}	is the importance of technology attribute <i>j</i> to pbc formation
<i>int</i>	is intention toward a technology
<i>pn</i>	is personal norms
w_{att}	is the weight of attitude in int formation
w_{pbc}	is the weight of pbc control in int formation
w_{pn}	is the weight of pn in int formation
<i>%peers</i>	is the percentage of peers using technology in question
<i>utility</i>	is the utility of a technology
$w_{social}(k)$	is the weight of social influence in decision-making of household <i>k</i>

Weights of components in the adoption-decision model are derived from the empirical survey and presented in Table 3.

Table 3. Weights of components in the adoption-decision model for the heating system adoption and diffusion in Norway

Components	Electric Heating	Heat Pump	Wood Pellet Heating
Preference ← ATT	0.699***	0.737***	0.707***
Preference ← PBC	0.350***	0.173***	0 (n.s.)
Preference ← PN	-0.058~	0.065~	-0.065~
PBC ← Fuel Price Stability	0.102~	0 (n.s.)	0.304***
PBC ← Indoor Air Quality	0.133**	0.128~	0 (n.s.)
PBC ← Functional Reliability	0.808***	0.904***	0.574***
PBC ← Total Cost	0 (n.s.)	0 (n.s.)	0 (n.s.)
PBC ← Required Work	0 (n.s.)	0 (n.s.)	0 (n.s.)
Household Group 1			
ATT ← Fuel Price Stability	0 (n.s.)	0 (n.s.)	0.406*
ATT ← Indoor Air Quality	0.507***	0 (n.s.)	0 (n.s.)
ATT ← Functional Reliability	0.402***	0.764***	0.639***

ATT ← Total Cost	-0.275*	0 (n.s.)	0 (n.s.)
ATT ← Required Work	0 (n.s.)	0 (n.s.)	0 (n.s.)
Household Group 2			
ATT ← Fuel Price Stability	0.369***	0 (n.s.)	0 (n.s.)
ATT ← Indoor Air Quality	0.284***	0.331***	0 (n.s.)
ATT ← Functional Reliability	0.395***	0.694***	0.568***
ATT ← Total Cost	-0.156~	0 (n.s.)	0 (n.s.)
ATT ← Required Work	0 (n.s.)	0 (n.s.)	0 (n.s.)
Household Group 3			
ATT ← Fuel Price Stability	0 (n.s.)	0 (n.s.)	0 (n.s.)
ATT ← Indoor Air Quality	0.523***	0.458*	0 (n.s.)
ATT ← Functional Reliability	0 (n.s.)	0.437~	0.573***
ATT ← Total Cost	0 (n.s.)	0 (n.s.)	-0.338*
ATT ← Required Work	-0.259~	-0.371*	-0.298*

*** $p < .001$; ** $p < .01$; * $p < .05$; ~ $p < 0.1$; n.s. = not significant

Note: the insignificant regression weights are set to zero in the model

The trigger for decision-making is represented by the variable “replacement time,” which symbolizes the time period needed to replace a heating system. The replacement could be due to a breakdown which could be assumed to be related to a heating system’s lifetime, or could be due to external events such as high fuel costs, subsidies or aggressive advertisements that may persuade households to change their heating system before its lifespan has been reached. Based on the results in empirical survey, approximately 70% of the respondents revealed that a breakdown is the most important motivation for replacing a heating system (Sopha et al., 2010a), with high fuel costs being the second most important reason. An average replacement time of 20 years, estimated from the survey, corresponds to the replacement time due to a system being out of order, which is subsequently implemented as the replacement time before the first electricity crisis. A previous study of heating systems in Norway provided evidence that high oil prices in 1986 were responsible for a shift from liquid fuel to electric heating (Brottemsmo, 1994), meaning that high fuel costs can trigger a replacement. This model therefore indicates that replacement time due to both broken equipment and high electricity costs are the main drivers of decision making. The latter is not covered in the survey, so the replacement time due to the electricity price peaks needs to be estimated. Indirect calibration is then used to derive a replacement time after the first electric crisis in the winter of 2002-2003. Bjørnstad (2005) provides information that can be used to estimate

replacement time after subsidy in 2003. Replacement times of 7 and 10 years were obtained and simulation runs for these two replacement times were conducted. It is discovered that a replacement time of 7 years yielded the best fit to historical data from both Statistics Norway (2006) and the survey (see Figure 3). It is subsequently applied in the next simulation run.

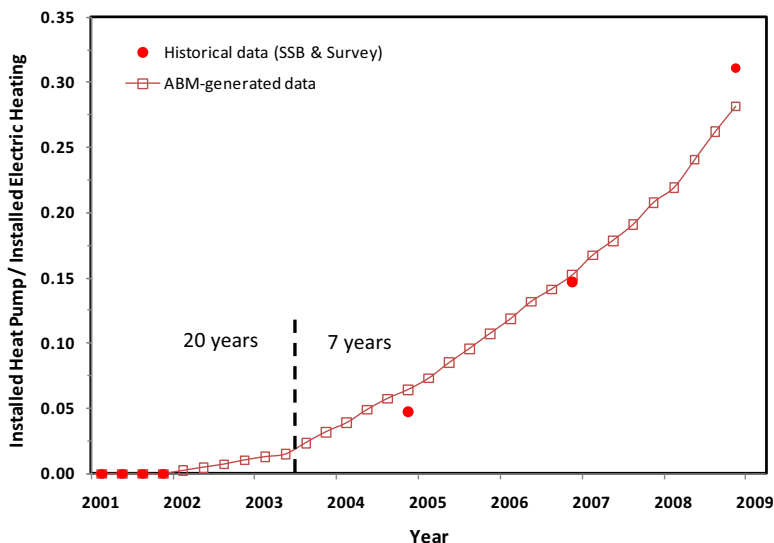

Figure 3. Model calibration for replacement time after electricity crisis

5.5. Model Structure

The overall model consists of model input, model component and model output, displayed in Fig. 4. The output of the simulation offers not only the aggregated result, i.e. a diffusion curve for each technology, but also the spatial distribution of the adopted technology over time.

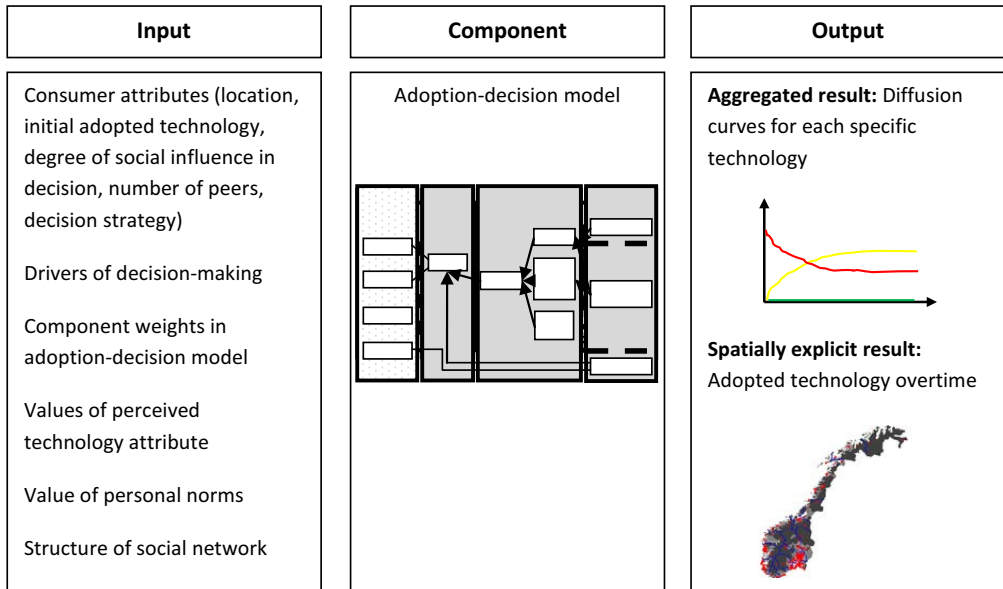

Figure 4. Model structure (Note: Social interactions among households in decision making are already captured in the adoption-decision model)

6. Simulation Results

The simulation start represented the year of 2001 when all the households in the simulation had the standard technology, i.e. an electric heating system, because, according to Statistics Norway (2006), the fractions of installed heat pump and wood pellet heating in 2001 were close to 0. Since the model contains random processes, e.g., when generating random interaction in a small-world routine, multiple runs (replications) of simulations using identical parameters and initial conditions are necessary to determine whether the results of a simulation run are representative. Following Garcia (2005), 30 replications are performed and results are the mean value of these replications.

6.1. Validation

This section aims to examine the extent to which the outcome of the simulation reproduces a real system's behavior which is acquired from independent data on both the macro- and micro-level. Fig. 5 displays agent-based simulation generated data for a heat pump versus independent data (Norsk Varmepumpeforening, 2006). The results for wood pellet heating are not shown in the figure because the adopted wood pellet heating obtained from the simulation result is quite small (0.16%)

in 2006 and shows no further adoption, which reflects well that the market share of wood pellet heating was 0.3% in 2006 (Statistics Norway, 2006) and that the market had been stagnant since then. In the mean time, the market for heat pumps has continuously grown despite the ceasing of subsidies from 2006. Unfortunately, a validation for electric heating could not be performed due to the unavailability of independent data. Fig. 5 shows that the model is reasonably able to reproduce the pattern of independent data at the macro-level.

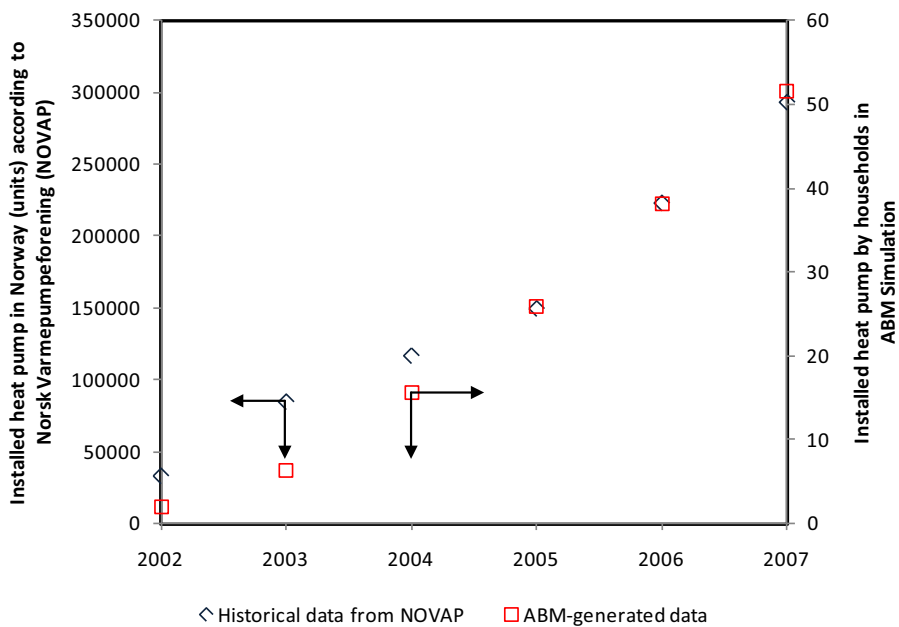

Figure 5. Macro-level validation for heat pump

With respect to micro-level behavior, the model simulated the adopted heating systems for the different household groups. As independent data is not available for this level, data from the survey not utilized in parameterization and calibration of the model is used. Thus, the agent-based generated data is compared to the survey data where the respondents were asked to indicate their main heating system at the time when the survey was conducted. Fig. 6 shows the percentage of adopted heating systems for different household groups over the last quarter of 2008. Chi² tests are conducted based on the assumption that the ABM-generated data produces the same results as the

historical data for different groups and heating system types. The tests indicate no significant differences except for heat pump adoption by household group 1. The model is argued to be reasonably able to replicate the actual system for household group 2 and 3, as well as, for electric and wood pellet heating.

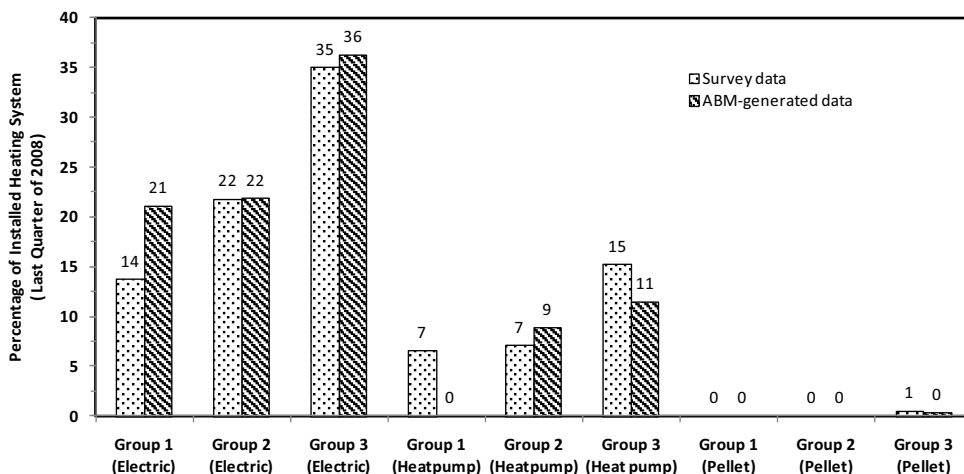

Figure 6. Percentage of installed heating system for different household groups in the last quarter of 2008 (based on the most frequent single run produced from 30 simulation runs)

6.2. Case Study

This section illustrates the application of the proposed methodology in adoption and diffusion of wood pellet heating in Norway. Given the ample supply of cheap hydropower in recent decades, electric resistance heating dominates the Norwegian residential heating market. Steady demand growth has now caught up with supply. Periods of low precipitation and/or high demand of energy due to long and cold winters, such as 2002-2003 and 2010 lead to high energy prices and to capacity problems of meeting the demand in Western and Central Norway. To reduce electricity dependency and consumption, the Norwegian government started in 2003 to subsidize the investment into heat pumps and wood pellet stoves. It is believed that reduced electricity use from households will, on the one hand, make electricity available for industry, electric cars and export in which the electricity imported from Norway replaces electricity produced abroad based on fossil

energy sources. On the other hand, the use of renewable heating systems in households contributes to meet the governmental goal of CO₂-neutral heating. While the subsidy for heat pumps has been successful, the subsidy for wood pellet ovens did not lead to a substantial diffusion of wood pellet heating. Three years after the introduction of the subsidy scheme, only 0.3% of households used wood pellets and the market continued to develop sluggish.

The provided financial subsidies have been of up to 20% of the installation cost. Sjøphal et al. (2010a) found that higher installation subsidy is required by Norwegian households to shift to wood pellet heating. The question raised is then whether the government should increase the subsidy to induce a more dynamic market development for wood pellet heating. Because the model does not differentiate between installation, maintenance and operation costs, we run the simulation with various reductions of 20%, 40% and 60% of the total cost in the case study.

The case study hence aims to examine the effect of various reductions in perceived total costs for wood pellet heating introduced in the first quarter of 2010. Fig. 7 shows the simulation results of fraction of adopted wood pellet heating over time for base model and 20%, 40% and 60% reductions of total cost for wood pellet heating. Although Fig. 7 shows an indication that the various reduction costs affect the adoption of wood pellet heating, but this effect is very small. Statistical analysis shows non-significant differences between base model and various total cost reductions (see Table 4). The results indicate that reduction of perceived total costs for wood pellet heating is not a guarantee that this heating system will be adopted. It implies that the reduction cost alone is not an effective driver for further diffusion of wood pellet heating. This could be explained by the fact that functional reliability and fuel supply security are more important than cost (Sjøphal et al., 2010a). Given the evidence that the cost reduction alone is not sufficient, other types of intervention should hence be considered. According to Vandenberg et al. (2010), the success of carbon emission reduction programs for the household sector critically depends on the combination of financial incentives and other design principles such as simplicity, quality assurance, and marketing.

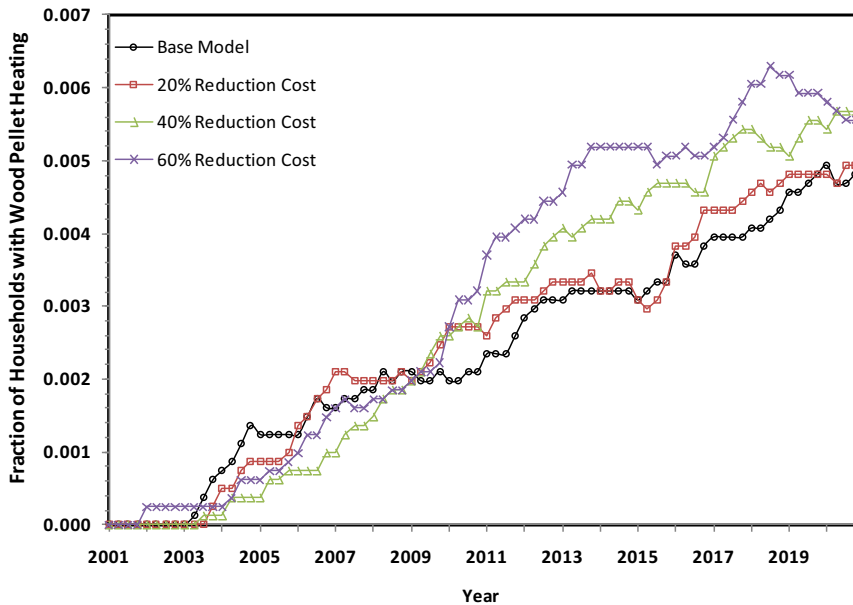

Figure 7. Base model vs. various reductions in perceived total cost of wood pellet heating

Table 4. *Chi*-square analysis of various reduction costs for wood pellet heating in comparison to base model

Reduction in Perceived Total Cost for Wood Pellet Heating	<i>Chi</i> -square Analysis
20% Reduction of Total Cost	$Chi^2 = 0.004; df = 79; p = 1$
40% Reduction of Total Cost	$Chi^2 = 0.019; df = 79; p = 1$
60% Reduction of Total Cost	$Chi^2 = 0.034; df = 79; p = 1$

7. Discussion

The coupling of ABM with empirical research enables the models to be more realistic. Employing the conceptual adoption-decision model derived from the literatures and parameterizing it using a survey results in a more realistic representation for the mechanisms of decision-making. The case study provided a first test of the proposed methodology to study technology adoption from the end-user perspective. The proposed methodology is argued to be generic and can be applied in different applications. Complementing ABM with an empirical survey to provide input parameter values for simulation also provides a strong empirical foundation of the agent-based model developed. It implies, at the same time, that calibration of the model is carried out (Fagiolo et al., 2006). However, the availability of high quality empirical data is important. Contrasting the

simulation result with other independent data is therefore necessary to assess the quality of the calibration.

With respect to the conceptual model, a comparable model has been implemented in modelling the diffusion of water-saving technologies in German households (Schwarz and Ernst, 2009). The differences rest on the inclusion of decision strategy (meta-theory) and personal norms, which are novel contributions of this study. The inclusion of these variables allows the consideration of a wider range of environmental behaviors among households including “irrational” behavior. It also allows a better structure of adoption-decision model.

Although the model allows for the investigation of different types of interventions, including soft strategies, regulation, and technical improvement, some limitations need to be highlighted. The main initiator of decision making was exogenous, i.e., replacement time, though this is a relatively constant when no external event ensues. At the same time, this implies that future model development should focus on the driving factors of chosen decision strategy based on external events or internal variables so that the driver of decision making is endogenous within the model. Hence, the initiation of decision-making becomes more dynamic.

Last but not least, it is important to note that the adoption-decision model determines the choice of heating system, thus implying that the interventions introduced to the simulation (e.g., improvement of technology attributes) contributes to the choice of heating system by Norwegian households. Nonetheless, the adoption rate of the chosen heating system is determined by a replacement time variable. As the model did not provide a detailed mechanism of replacement, the model is not intended for quantitative prediction. Therefore, the quantitative results of agent-based simulation should be interpreted in qualitative terms, i.e., the model could inform about the general pattern of the future adoption and diffusion of technology, but could not predict accurately the number of adopted technologies over time, unless the information on the trigger of decision-making is precise enough to draw conclusions in a quantitative manner.

8. Conclusion

The successful introduction of environmentally friendly technology requires the understanding of consumer choice as the key factor to address the issue on technology adoption/diffusion. Coupling agent-based modelling with empirical research enables to construct and calibrate realistic models to support policy design and assessment. The conceptual model which combined diffusion of innovation theory, theory of planned behavior, utility theory and meta-theory offered a better representation of the decision-making process. The combination with an empirical survey provides an empirical foundation of the agent-based model. The application of the model to the case of heating system adoption and diffusion in Norway provided evidence that the proposed methodological approach is promising and thus opens the possibility to be implemented in other applications.

9. Acknowledgement

Financial support provided by Norwegian University of Science and Technology (NTNU), Norway, is gratefully acknowledged. A special thanks to Linda Ariani Gunawan for her assistance of reviewing programming codes.

10. References

Ajzen, I., 1991. The theory of planned behavior. *Organ. Behav. Hum. Dec. Processes* 50, 179-211.

Andrews, C., DeVault, D., 2009. Green niche market development: A model with heterogeneous agents. *J. Ind. Ecol.* 13, 326-345.

Bamberg, S., Ajzen, I., Schmidt, P., 2003. Choice travel mode in the Theory of Planned Behavior: The roles of past behavior, habit and reasoned action, *Basic Appl. Soc. Psych* 25, 175-187.

Brottemsmo, J., 1994. Residential Heating Choice and Energy Demand: Norwegian Responses in 1980 and 1990. Working Paper No. 118/1993, Center of Research in Economics and Business Administration.

Fishburn, P.C., 1970. *Utility Theory for Decision Making*. Publications in Operations Research, No. 18. New York: John Wiley and Sons.

Garcia, R., 2005. Uses of Agent-based Modeling in Innovation/New Product Development Research. *J. Prod. and Innovat. Manag.* 22, 380-398.

Inglehart, R., Abramson, P.R., 1999. Measuring postmaterialism. *Amer. Polit. Sci. Rev.* 93, 665-677

Jager, W. 2000. *Modeling consumer behavior*, Doctoral thesis, Rijksuniversiteit Groningen, the Netherlands.

Janssen, M. A., Jager, W., 2002. Stimulating diffusion of green products: Co-evolution between firms and consumers. *J. Evolutionary Econ.* 12, 283-306.

Janssen, M. A., Ostrom, E., 2006. Empirically based, agent-based models. *Ecology and Society* 11, 37. Accessed in 2008, <http://www.ecologyandsociety.org/vol11/iss2/art37/>.

Jeyaraj, A., Rottman, J., Lacity, M., 2006. A review of predictors, linkages and biases in IT innovation adoption research. *J. Inform. Technol.* 21, 1-23.

Kasanen, P. , Lakshmanan, T. R., 1989. Residential Heating Choices of Finnish Household. *Econ. Geogr.* 65, 130-145.

Klöckner , C. A., Blöbaum, A., 2010. A comprehensive action determination model: Toward a broader understanding of ecological behavior using the example of travel mode choice. *J. Environ. Psychol.* 30, 574-586.

Mahapatra, K., Gustavsson, L., 2008. An adopter-centric approach to analyze the diffusion patterns of innovative residential heating systems in Sweden. *Energ. Policy* 36, 577-590.

Midgley, D. F., Morrison, P.D., Roberts, J. H., 1992. The effect of network structure in industrial diffusion processes. *Res. Pol.* 21, 533–552.

Naivinit, W., Le Page, C., Trebuil, G., Gajaseni, N. ,2010. Participatory agent-based modelling and simulation of rice production and labor migrations in Northeast Thailand. *Environ. Model. Software* 25, 1345-1358.

Norsk Varmepumpeforening, 2006. Accessed in November 2009, <http://www.novap.no/>.

Panebianco, S., Pahl-Wostl, C., 2006. Modelling socio-technical transformations in wastewater treatment – A methodological proposal. *Technovation* 26, 1090-1100.

Reusswig, F., Lotze-Campen, H., Gerlinger, K., 2008. Changing global lifestyle and consumption patterns: the case of energy and food, Potsdam Institute for Climate Impact Research. Accessed June 2008, http://www.populationenvironmentresearch.org/papers/Lotze-Campen_Reusswig_Paper.pdf.

Rogers, E. M., 1962. *Diffusion of Innovations*. The Free Press, New York.

Rogers, E. M., 2003. *Diffusion of Innovations*, 5th ed. The Free Press, New York.

Schwarz, N., Ernst, A., 2009. Agent-based modeling of the diffusion of environmental innovations – An empirical approach. *Technol. Forecast. Soc. Change* 76, 497-511.

Schwoon, M., 2006. Simulating the Adoption of Fuel Cell Vehicles, *J. Evolutionary Econ.*, 16, 435-472.

Smajgl, A., 2010. Challenging beliefs through multi-level participatory modelling in Indonesia. *Environ. Model. Software* 25, 1470-1476.

Sopha, B. M., Klöckner, C. A., Hertwich, E.G., 2010a. Adopters and non-adopters of wood pellet heating in Norwegian households. *Biomass and Bioenergy* (forthcoming).

Sopha, B. M., Klöckner, C. A., Hertwich, E. G., 2010b. The influence of the social network structure on the diffusion of heating system in Norway. In Ernst, A., and Kuhn, S. (Eds.) 2010. *Proceeding of 3rd World Congress on Social Simulation WCSS2010*. Kassel, Germany: Center for Environmental Systems Research, University of Kassel.

Sopha, B. M., Klöckner, C. A., Skjevrak, G., Hertwich, E. G., 2010c. Norwegian households' perception of wood pellet stove compared to air-to-air heat pump and electric heating. *Energ. Policy* 38, 3744-3754

Statistics Norway, 2006. Accessed December 2009, <http://www.ssb.no/husenergi/tab-2008-04-28-08.html>.

Stern, P.C., 2005. Understanding individuals' environmentally significant behavior. *Envtl. L. Rep. News and Analysis* 11, 10785-10790.

Tonglet, M., Phillips, P. S., Read, A.D., 2004. Using the Theory of Planned behavior to investigate the determinants of recycling behavior: a case study from Brixworth, UK, *Resour. Conserv. Recy.* 41, 191-214.

Valente, T. W. 1996. Social network thresholds in the diffusion of innovation. *Soc. Network* 18, 69-89.

Vandenbergh, M. P., Stern, P. C., Gardner, G. T., Dietz, T., Gilligan, J. M., 2010. Implementing the behavioral wedge: Designing and adopting effective carbon emissions reduction programs. *Envtl. L. Rep.* 40, 10545-10552.

Wilson C., Dowlatabadi, H., 2007. Models of decision making and residential energy use. *Ann. Rev. Environ. Resour.* 32, 169-203.

The Influence of the Social Network Structure on the Diffusion of Heating System in Norway

Bertha Maya Sopha

*Industrial Ecology Programme and Department of Energy and Process Engineering
Norwegian University of Science and Technology
N-7491 Trondheim, Norway*

Christian A. Klöckner

*Department of Psychology, Section for Risk Psychology, Environment and Safety
(RIPENSA)
Norwegian University of Science and Technology
N-7491 Trondheim, Norway*

Edgar G. Hertwich

*Industrial Ecology Programme and Department of Energy and Process Engineering
Norwegian University of Science and Technology
N-7491 Trondheim, Norway*

In Ernst, A. and Kuhn, S. (Eds) 2010. *Proceeding of 3th World Congress on Social Simulation WCSS 2010*, Kassel, Germany: Center for Environmental Systems Research, University of Kassel.

The Influence of the Social Network Structure on the Diffusion of Heating System in Norway

Bertha Maya Sopha^{1*}, Christian A. Klöckner², Edgar G. Hertwich¹

¹ Industrial Ecology Programme and Department of Energy and Process Engineering

² Department of Psychology, Section for Risk Psychology, Environment and Safety
Norwegian University of Science and Technology (NTNU)

NO-7491 Trondheim, Norway

*corresponding author: bertha.sopha@ntnu.no

Abstract. An agent-based simulation was developed as a tool for exploring the effect of government interventions on the adoption of a heating system. This paper describes the conceptual framework of adoption-decision making based on models from different theories; meta-theory (social psychology/consumer behavior), utility theory (behavioral economics), Theory of Planned Behavior (psychology), and Diffusion of Innovation (technology management). A mail survey of 270 Norwegian households in 2008 was designed specifically for acquiring data to feed the simulation. Simulation result of the influence of the social network structure on diffusion rate is presented. The result suggested that the small-world network is the most representative network structure, in comparison to spatial proximity and random network, within the context of household's heating system adoption and diffusion.

Keywords: Agent-based simulation, heating system, diffusion, Norway, social network structure.

1 Introduction

Norwegian residential space heating which has been dominated by electric heating due to the public investment in hydropower between 1960 and 1990, accounts for approximately 50% of households' energy use [1]. Because hydropower production is significantly affected by precipitation, the supply security of electricity has become an issue when low precipitation is combined with a cold winter. The electricity price peak in the winter of 2002-2003 prompted a significant number of Norwegian households to consider substituting their heating systems. Heat pumps and wood pellet heating were considered promising options to reduce electricity consumption and to diversify the heating supply for domestic households, and consequently received governmental subsidy. However, the subsidy scheme did not lead to a higher diffusion of wood pellet heating, whereas air-to-air-heat pump diffusion continued even after subsidies for this technology were terminated in 2006. Statistics reported that the fraction of households with pellet stoves installed in 2006 was 0.003 [2]. The overall objective of the study is to understand the slow uptake of wood pellet heating and to explore potential interventions to achieve the government's goal of a more

wide-spread utilization. The focus of this paper is specifically to study the influence of the social network structure on the diffusion rate and to select the most representative structure for the later phase of this simulation study. Conceptual design and data acquisition method are discussed briefly.

Previous studies of heating system adoption have investigated socio-demographic factors, communication, and decision strategies that determine adoption [3-5]. One common limitation of these works is the lack of realistic representation of spatial location, actor heterogeneity, and interaction. Moreover, the dominating use of statistical tools such as discrete choice models for modeling consumer choice, based on a static description of the decision making, is unable to represent the dynamicity of a system affected by social change, external pressures or micro-level drivers. In contrast to that, agent-based modeling (ABM) introduces the concept of agents represented as autonomous and interacting [6]. Studies of complex systems have demonstrated that unexpected results, so-called emergent phenomena, may result from simple rules performed by different autonomous actors in the system. The approach is able to represent the heterogeneity of households, to symbolize agents in particular location in landscape, and to explicitly model the interactions among agents. Moreover, ABM allows using different information sources, such as sample surveys, experts' opinion, and reports, to be incorporated into the model.

2 Conceptual Model and Data Acquisition

The process by which a new technology is adopted and diffused can be studied from a number of perspectives. Four different perspectives, i.e. meta-theory [7], utility theory [8], Theory of Planned Behavior (TPB) [9] and Diffusion of Innovation (DoI) [10], were taken into account in developing the adoption-decision model to be implemented in the agent-based simulation presented in this paper.

Households employ different decision-making strategies depending on external and internal conditions. Individuals do not always make consistently rational decisions. They rather use a wide range of rules or heuristics to reduce the effort of cognitive processing. The meta-theoretical approach, an integrative framework of consumer behavior [7], is applied to represent which decision strategy is performed by each household. Four different decision strategies are outlined in this theory (1) Repetition which represents habitual decision-making, (2) Deliberation which evaluates all the available alternatives, (3) Imitation which assumes the social network as the only influence, and (4) Social comparison which selects the most advantageous heating system out of the previously used and the system most adopted by neighbors. Furthermore, utility theory, TPB, and DoI are used as a blueprint to present the mechanisms involved in the different decision strategies. Each decision strategy follows its own line of decision processing as shown in Fig.1. For instance, Repetition copies the previous decision. Deliberation and Social Comparison follow the utility calculation to combine preference and social influence, while Imitation considers only social influence when making decision.

Diffusion of Innovation theory [10] recognizes that different characteristics of potential adopters and perceived innovation attributes may ease or hinder adoption.

While the DoI theory conceives of innovation attributes as components of attitude formation, TPB assumes that not only attitudes but also normative beliefs and perceived behavioral control (PBC) are predictors of intention, which will then predict adoption [9]. The perception of heating system attributes are used as explanatory variables for attitudes, as they turn out to be part of the belief system, and perceived behavioral control, as they might increase or hamper the perceived ability of adoption. Five specific heating system attributes adopted from Mahapatra and Gustavsson [3] were applied (see Fig. 1). Personal Norms, articulated as the household's moral responsibility to use an environmentally friendly heating system, are represented as addition to the TPB structure. Utility theory [8] is used to frame decision elements rooted from both household's preference and social influence as, according to DoI, decisions are not only related to individual needs but also social requirements [10].

A comparable model has been employed in simulating the diffusion of water-saving technology in German households [11]. In contrast to the German study, it explicitly modeled that households held different decision strategies and the personal norms were included as a predictor of preference.

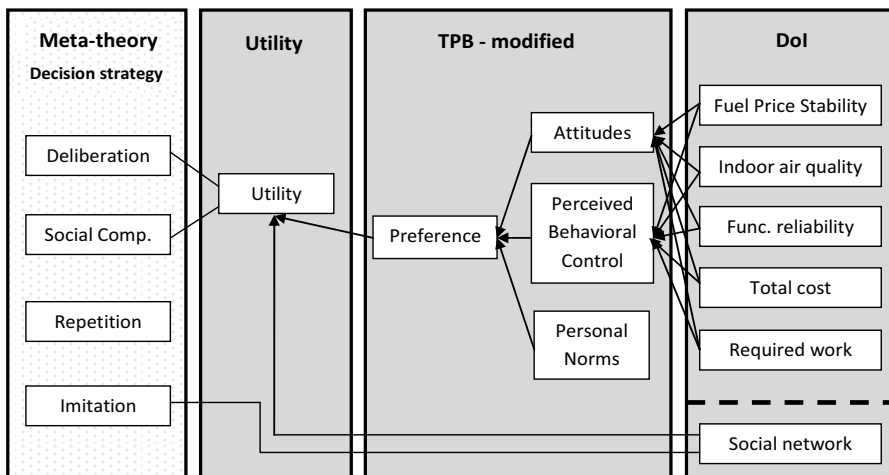

Fig. 1. Adoption-Decision Model

Using the model above, an empirical survey was conducted in 2008 to collect individual household data such as location, number of peers to whom a household communicates about heating technology, the employed decision strategy, and the degree of social influence on decisions. Psychological data for different heating systems (preference/intention, attitudes, PBC, personal norms, and perceived heating system attributes) were collected to derive parameter weights of components in the adoption-decision model (see Fig. 1) as well as to set initial values of user-settable parameters, i.e. perceived attributes of heating systems and personal norms. In addition, the frequency of and motivations for heating system replacement were gathered. One thousand five hundreds questionnaires were sent to Norwegian homeowners, due to the self-determining authority in making decision about heating system, drawn as a random sample from the population register. After three weeks, the response rate was 10.3% (154 questionnaires). Additional responses of 137

questionnaires were received after a reminder sent three weeks later, resulting in a response rate of 19.4% (291 responses). Due to missing values, the final analysis was based on a sample of 270 households. The response sample was representative for Norwegian households with respect to age and geographical distribution.

3 Agent-Based Model

The model is applied to cover the country of Norway which has a total size of 385 252 km² with approximately 4.8 million people living in the region. The populated areas are mostly located along the south and west coast of Norway (see Fig.2).

3.1 Household agents

An agent is a decision making entity in the agent-based model. An agent within this model represents one specific household drawn from the empirical survey. Each household agent is characterized by a number of individual parameters, i.e. geographical location, employed decision strategy (based on meta-theory), degree of social influence when making decision (0-100%), number of peers/neighbors to whom households communicate about a heating system, and the currently adopted heating system.

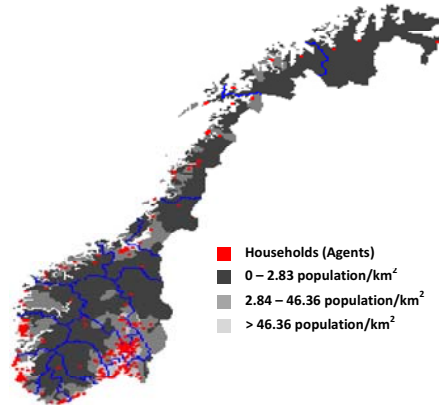

Fig. 2. Household agents

3.2 Heating systems

Three types of heating systems are examined: direct electric heating (the standard technology in Norway), the individual wood pellet stove, and air-to-air heat pumps (hereafter referred to as heat pump). The households decide on one of the heating system options which compete with each other¹. Each heating system is characterized

¹ Most of Norwegian households utilize more than one type heating system, this study however only models the main heating system

by a specific evaluation based on multiple attributes such as perceived fuel price stability, indoor air quality, functional reliability, total cost, and upkeep work. A series of regressions were performed for each type of heating system under study to estimate the weight of different components in the adoption-decision model.

3.3 Decision-making process

A trigger for installation decision in this model is represented by a replacement time, which is not necessarily corresponding to a heating system's lifetime, representing that households would change their heating system after a certain time period. An average replacement time of 20 years corresponding to the replacement time before electricity crisis in 2003 was obtained from the survey, and thus used as initial value. The replacement time however needs to be adjusted with the presence of external events, such as extremely high electricity price that was evidently leading to shorter replacement time [12]. As one time step was defined to represent a quarter of a year (3 months), an "installation rate" was introduced to establish a meaningful representation of time. This allows that all household agents decide simultaneously in each time step but the decision choice of each household will only convert to installation to a certain fraction which is the installation rate. For instance, the replacement time of 20 years corresponds to an installation rate of 1.25% per quarter.

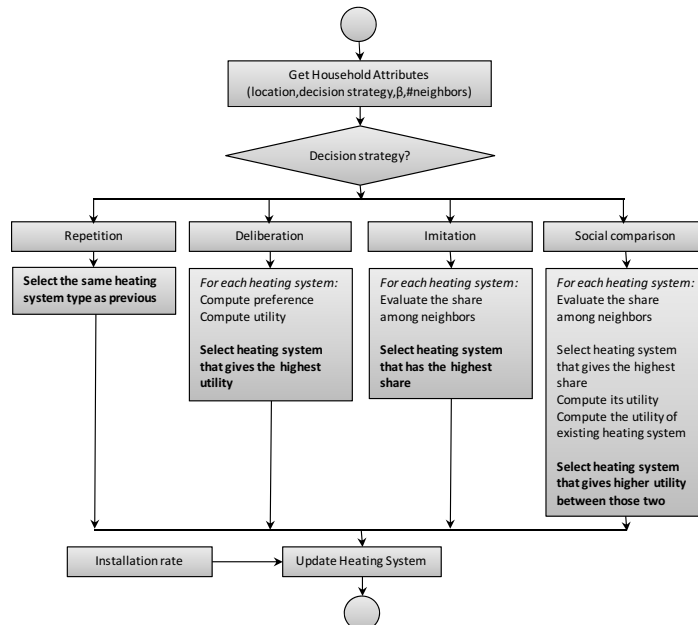

Fig. 3. Decision process algorithm

Depending on the selected decision strategy, one of four algorithms (see Fig.3) is employed to decide upon the heating systems. Nonetheless, the decision strategy is not the same over time as households are exposed to different situations over time even though decisions made for the heating systems are infrequent. Instead of

assigning households to the same decision strategy over time, the households select their decision strategy in each time step with the probabilities derived from empirical survey².

3.4 Social network

Households depending on their decision strategy are interacting with each other when making a decision, connected through their social network. The interaction thus has an influence to the decision that depends on the households' neighbors/peers, the stated degree of social influence, employed decision strategy, location, and social network structure. From the literatures, there are different approaches to model a social network in an agent-based simulation. One type of network structures is based on spatial proximity, such as in a Moore network [13] and Von Neumann network [14]. Another network known as random network, in which each household communicates with other households randomly, was first introduced by Erdős and Rényi [15]. Since real networks are unlikely to be purely random, Watts and Strogatz [16] have introduced regular network 'rewiring', a so-called small-world network. With respect to the small-world network, the model sets a rule that each household interacts with its neighbors based on spatial proximity, neighbors within its 'radius', and random interactions to other actors outside the radius to enable the social network in the model to have the attributes of a small-world effect. The number of household's neighbors was determined by the survey. The algorithm difference among those three approaches is presented in Fig. 4. The scale-free network is not investigated in this study [17].

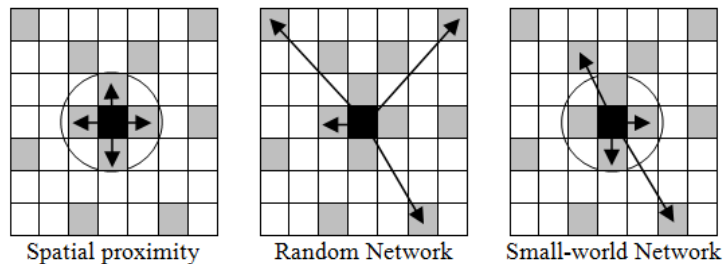

Fig. 4. Different social network structures with 4 neighbors

4 Simulation

The model was implemented in the Repast Java platform (<http://repast.sourceforge.net/>). The simulation starts in 2001 with a single heating system, electric heating, in all households. Multiple runs (replications) of identical

² This simulation work offers the preliminary model, not suggested as the final one. The drivers of the decision strategy should be developed in later versions of the model.

initial conditions are necessary to determine if the conclusion from a simulation run is representative. Thirty replications were carried out, which is within the range of most researchers performed [18]. All parameter values were derived from the survey, no estimation or guess was made. However, replacement time was adjusted (from 2003) due to high electricity price and subsidy introduction, based on the data from Bjørnstad [12] and Norsk Varmepumpeforening [19]. As independent historical data of adopted heating systems in Norway are available for the years 2001, 2004, and 2006 [2], in addition to the survey data in 2008, the simulation therefore covers the time period of 2001-2008.

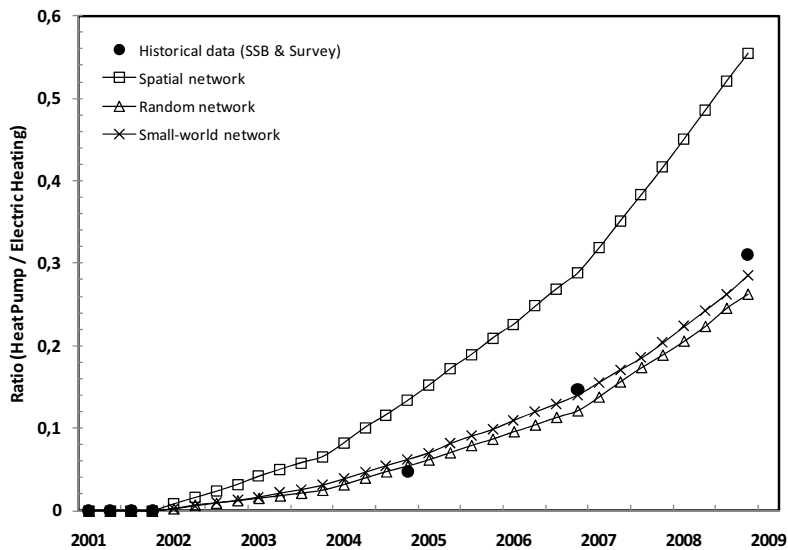

Fig. 5. Ratio of adopted heat pump and electric heating for different structure of social network in comparison to historical data

Fig.5. shows that different structures of social network, as expected, result in different diffusion patterns. Different studies on modeling the DoI in social network summarized by Garcia [18] and the study of Schwartz and Ernst [11] identified that network structure significantly impacted the diffusion rate of innovations. Moreover, it is found that the small-world structure gives the best fit with historical data, while spatial proximity performs worst. The random network shows only a slightly different adoption compared to the small-world network. The result suggests that the small-world network structure offers the best representation of the household social network structure within the context of heating system adoption and diffusion. The small-world network was also found in the network structures of the collaboration graph of actors in feature films, the electrical power grid of the western United States, and the neural network of the nematode worm *C.elegans* [16].

However, the result of wood pellet heating is not shown because the simulated wood pellet adoption is quite small (0.001 with small-world network) and stagnating. This result also reflects the observed adoption of 0.003 [2] and the lack of market development.

5 Conclusion

This paper has introduced a theoretical-based, empirical-founded, agent-based model for simulating the diffusion of heating system to study the influence of social network structure on diffusion rate. The model suggests that the small-world network is the best representation of social network structure within this context. Further research in the near future will be conducted to develop scenarios to identify potential interventions to increase the uptake of wood pellet heating.

Acknowledgments. Financial support provided by Norwegian University of Science and Technology (NTNU), Norway, is gratefully acknowledged.

References

1. Larsen, B. M. and Nesbakken, R.: Formålsfordeling av Husholdningenes Elektrisitetsforbruk i 1990 og 2001, Økonomiske analyse 4 (2005), in Norwegian
2. Statistics Norway, SSB (2006), <http://www.ssb.no/husenergi/tab-2008-04-28-08.html>
3. Mahapatra, K., and Gustavsson, L.: An Adopter-Centric Approach to Analyze the Diffusion Patterns of Innovative Residential Heating Systems in Sweden, *Energy Policy* 36, 577-590 (2008)
4. Kasanen, P. and Lakshmanan, T. R.: Residential Heating Choices of Finnish Household *Econ. Geogr.* 65, 130-145(1989)
5. Sopha, B. M., Klöckner, C. A., Skjevraak, G., and Hertwich, E. G.: Norwegian Households' Perception of Wood Pellet Stove Compared to Air-to-Air Heat Pump and Electric Heating, *Energy Policy* 38, 3744-3754 (2010)
6. Gilbert, N., Troitzsch, K. G.: *Simulation for the Social Scientist*. Open University Press, Buckingham (1999)
7. Jager, W.: *Modeling consumer behavior*, Doctoral thesis, Rijksuniversiteit Groningen, the Netherlands (2000)
8. Tversky, A., Kahneman, D.: The Framing of Decisions and the Psychology of Choice, *Science* 211, 453-458 (1981)
9. Ajzen I.: The Theory of Planned Behavior. *Organ. Behav. Hum. Dec.* 50, 179-211 (1991)
10. Rogers, E. M.: *Diffusion of Innovations*, 5th ed., New York: Free Press (2003)
11. Schwarz, N., and Ernst, A.: Agent-Based Modeling of The Diffusion of Environmental Innovations – An empirical Approach, *Technol. Forecast. Soc.* 76, 497-511 (2009)
12. Bjørnstad, E., Grande, J., Sand, R. and Wendelborg, C.: Evaluering av Tilskuddordninger til Varmepumper, Pelletskaminer og Styringsystemer, Nord Trøndelags-forskning, in Norwegian (2005)
13. Weisstein, Eric W. "Moore Neighborhood." From MathWorld--A Wolfram Web Resource. <http://mathworld.wolfram.com/MooreNeighborhood.html>
14. Weisstein, Eric W. "von Neumann Neighborhood." From MathWorld--A Wolfram Web Resource. <http://mathworld.wolfram.com/vonNeumannNeighborhood.html>
15. Erdős, P. & Rényi, A.: On Random Graphs. I. *Publ. Math-Debrecen* 6, 290–297 (1959)
16. Watts, D. J. and Strogatz, S. H.: Collective dynamics of small-world networks, *Nature* 393, 409-10 (1998)
17. Albert, R. & Barabási A.-L.: *Statistical Mechanics of Complex Network*, *Rev. Mod. Phys.* 74, 47-97 (2002)
18. Garcia, R.: Uses of Agent-based Modeling in Innovation/New Product Development Research, *J. Prod. and Innovat. Manag.* 22, 380-398 (2005)
19. Norsk Varmepumpeforening (2006), <http://www.novap.no/>

**Exploring Policy Options for a Transition to Sustainable Heating
System Diffusion using an Agent-Based Simulation**

Bertha Maya Sopha

*Industrial Ecology Programme and Department of Energy and Process Engineering
Norwegian University of Science and Technology
N-7491 Trondheim, Norway*

Christian A. Klöckner

*Department of Psychology, Section for Risk Psychology, Environment and Safety
(RIPENSA)
Norwegian University of Science and Technology
N-7491 Trondheim, Norway*

Edgar G. Hertwich

*Industrial Ecology Programme and Department of Energy and Process Engineering
Norwegian University of Science and Technology
N-7491 Trondheim, Norway*

Accepted in Energy Policy 2011

Is not included due to copyright

**Using Systems Engineering to Create a Framework for Evaluating
Industrial Symbiosis Options**

Bertha Maya Sopha

*Industrial Ecology Programme and Department of Energy and Process Engineering
Norwegian University of Science and Technology
N-7491 Trondheim, Norway*

Annik Magerholm Fet

*Department of Industrial Economics and Technology Management
Norwegian University of Science and Technology
N-7491 Trondheim, Norway*

Martina Maria Keitsch

*The Oslo School of Architecture and Design
N-0130 Oslo, Norway*

Cecilia Haskins

*Department of Industrial Economics and Technology Management
Norwegian University of Science and Technology
N-7491 Trondheim, Norway*

Is not included due to copyright