

Thomas Meyn

# **NOM Removal in Drinking Water Treatment Using Dead- End Ceramic Microfiltration**

Assessment of Coagulation/Flocculation Pretreatment

Thesis for the degree of Philosophiae Doctor

Trondheim, April 2011

Norwegian University of Science and Technology  
Faculty for Engineering Science and Technology  
Department of Hydraulic and Environmental Engineering



**NTNU – Trondheim**  
Norwegian University of  
Science and Technology

**NTNU**

Norwegian University of Science and Technology

Thesis for the degree of Philosophiae Doctor

Faculty for Engineering Science and Technology  
Department of Hydraulic and Environmental Engineering

© Thomas Meyn

ISBN 978-82-471-2459-8 (printed ver.)  
ISBN 978-82-471-2460-4 (electronic ver.)  
ISSN 1503-8181

Doctoral theses at NTNU, 2011:3

Printed by NTNU-trykk

# Abstract

In Nordic countries, surface water is a common source for potable water production. Such waters are often characterised by high Natural Organic Matter (NOM) content, resulting in high colour, very low turbidity, low alkalinity and low hardness due to natural conditions. Treatment of such waters basically comprises the removal of NOM and colour, corrosion control and disinfection. Although the largest part of NOM is not harmful, some fractions can cause colour, taste and odour problems or can even be toxic. Complexation of heavy metals and organic micro-pollutants, mobilizing them and making them available in the water phase, and increasing the amount of necessary disinfectants as well as being recognized as precursors for disinfection by-product formation which can be carcinogenic, are issues to be considered. In addition, there is a growing concern on the increase of NOM in natural water sources. Recent studies have shown that the concentration of NOM in surface water has increased in the last decades and may increase further during the coming decades, caused by progressing climate change issues and/or changed precipitation patterns. Thus, the removal of NOM is one of the major concerns and makes advanced drinking water treatment necessary.

In the past, conventional treatment processes such as coagulation/rapid sand filtration and filtration by nanofiltration (NF) membranes have been used successfully in Norway. However, a number of disadvantages have been identified in these processes. While the quality of effluent from rapid filters is high if coagulation is optimised, it may be severely compromised if coagulation fails, or operation is unstable. NF membranes have been subject to high irreversible fouling. High operating pressures at low fluxes, permeability loss over time and high chemical demands for cleaning have been observed frequently. By contrast, low pressure membrane filtration has emerged as an alternative for direct surface water treatment in recent years, with number of installations increasing rapidly around the world. Disadvantages as described above can be avoided to a large extent with this technology. The usage of low pressure membrane processes leads to high, stable effluent quality compared to conventional technologies, especially with regards to hygienic aspects since water borne parasites and most of bacteria can be retained. By applying ceramic microfiltration (MF) a more energy efficient operation is possible, the higher investment costs for ceramic membranes can

be offset by the ability to operate with significantly higher fluxes. However, such membranes demand coagulation pre-treatment in order to achieve sufficient NOM and colour removal, fulfil the requirements as a hygienic barrier as well as for the control fouling by NOM.

This study showed that coagulation, combined with subsequent ceramic MF, is a successful concept for the direct treatment of Nordic waters. In spite of high NOM content in the raw water (DOC 6.8 mg C/L, colour 55 mg Pt/L), stable operation was demonstrated at high membrane fluxes of up to 250 L/(m<sup>2</sup> h), achieving irreversible membrane fouling below 1 mbar/h, a DOC removal of 70% and colour removal of around 90%, at a coagulant dosage of 0.65 mg Al per mg DOC (using PACL at pH 6, with 60s of inline flocculation). While NOM removal depended only on coagulant dosage and coagulation pH, membrane fouling was also influenced by flocculation type, time and G-value. The study also found that the optimization of coagulation pre-treatment is crucial. If, for example, an insufficient amount of coagulant is dosed, membrane fouling increases drastically, residual metal concentration is high and NOM removal is minimal. Inline coagulation with a static mixer, followed by pipe flocculation, showed promising results compared to conventional tank coagulation, where irreversible fouling rates observed were in the same range. However, reversible fouling was significantly lower after tank coagulation and flocculation, in spite of floc breakage in the membrane feed pump. Indications are thus that, either the properties of the broken flocs are significantly different from freshly created ones, or that flocs re-grow in the membrane capillaries.

Additional findings of this study show that if the coagulation pre-treatment is optimised, MS2 bacteriophages can be efficiently removed from surface water characterized by high NOM content. Removal rates of 6 log units up to complete virus retention were achieved, at pH values ranging from 5.0 to 5.5. However, at such conditions the residual metal concentration exceeded legal limits. In order to avoid this, it is advised that the coagulation pH should be increased to 6 or higher. At these pH-values efficient virus removal can still be achieved, however, higher coagulant dosages are required. By optimizing coagulation/flocculation pre-treatment, an efficient removal of NOM can be achieved while complying with hygienic barrier requirements, resulting in virus removal of 4 log units and higher. Coagulation/flocculation pre-treatment coupled with ceramic MF filtration is thus a viable and flexible treatment scheme for the production of high quality potable water from surface waters having high NOM concentrations.

# Acknowledgements

This work is based on experimental results carried out in the period of 2006 to 2010 at the Department of Hydraulic and Environmental Engineering, Norwegian University of Science and Technology (NTNU), located in Trondheim, Norway. During that time I had great support and encouragement from many sides and I would like to express my gratitude to them.

In particular, I would like to thank Prof. Tor Ove Leiknes for supervising this work, his openness to my ideas and for his advice, support, encouragement and feedback throughout the years. Thank you also for dragging me out of the office in order to attend international conferences for the presentation and discussion my work.

In addition, many people have supported me in different ways. I would like to thank my co-supervisor Prof. Hallvard Ødegaard as well as Prof. Liv Fiksdal and Prof. Stein W. Østerhus for their assistance during my time at the department and for sharing their expert knowledge with me. I thank Trine Hårberg and Gøril Thorvaldsen for their great assistance in the laboratory, as well as Arne Grostad and Torgeir Jensen for their assistance with the experimental setup and technical issues.

A special thank goes to all my colleagues and fellow students, with whom I had not only fruitful discussions, but which also created a great working atmosphere. Especially I would like to mention Igor Ivanovic, Cheng Sun, Gema Sakti Raspati, Astrid Bjørkøy, Kamal Azrague, Esa Melin, Ciprian Scurtu and Sumihar Silalahi. A special thanks goes to Jirachote Phattaranawik, my all time favourite “after lunch ping-pong partner”.

Furthermore, I would like to express my gratitude to Metawater Co., Ltd., Japan, for providing the pilot plant with all its associated equipment and the ceramic membranes. Whenever I had a problem with the plant or in case I needed assistance or spare parts, they have been a reliable partner and source of help.

This thesis would never have been completed without the support of my partner Ivonne. Thanks for your encouragement and endless patience, especially during the last months

of the writing. After this chapter is closed, it will be your turn. Finally, my deep gratitude to my parents for all their patience and support during my study back in Germany and my adventures abroad in Australia and Norway. Without that, I would not be where I am now.

Trondheim, November 2010  
Thomas Meyn

# Contents

|  |             |
|--|-------------|
| <b>Abstract</b> .....  | <b>iii</b>  |
| <b>Acknowledgements</b> .....                                | <b>v</b>    |
| <b>Contents</b> .....  | <b>vii</b>  |
| <b>List of Figures</b> .....                                 | <b>xi</b>   |
| <b>List of Tables</b> .....                                  | <b>xvii</b> |
| <b>Abbreviations</b> .....                                   | <b>xix</b>  |
| <b>1 Introduction</b> .....                                  | <b>1</b>    |
| 1.1 Background .....   | 1           |
| 1.2 Drinking water treatment perspectives .....              | 3           |
| 1.3 Challenges.....  | 5           |
| 1.4 Structure of thesis .....                                | 5           |
| <b>2 Scope of thesis</b> .....                               | <b>7</b>    |
| 2.1 Scope.....   | 7           |
| 2.2 Rationale .....  | 8           |
| 2.2.1 Why monolith ceramic membranes? .....                  | 9           |
| 2.2.2 Coagulation-MF compared to conventional processes..... | 11          |
| 2.3 General research questions and assumptions .....         | 14          |
| 2.4 Hypotheses .....   | 15          |
| 2.5 Specific research objectives .....                       | 18          |
| <b>3 Coagulation and flocculation</b> .....                  | <b>19</b>   |
| 3.1 Surface chemistry.....                                   | 19          |

|          |   |           |
|----------|---|-----------|
| 3.2      | Coagulants.....   | 22        |
| 3.2.1    | Metal based coagulants.....   | 22        |
| 3.2.2    | Polymers .....  | 26        |
| 3.3      | Coagulation mechanisms .....  | 27        |
| 3.4      | NOM coagulation with metal salts .....                              | 30        |
| 3.5      | Coagulation at low temperatures .....                               | 35        |
| 3.6      | Flocculation.....   | 37        |
| 3.7      | Filtration residues after coagulation.....                          | 38        |
| <b>4</b> | <b>Removal of NOM from surface water.....</b>                       | <b>41</b> |
| 4.1      | Rapid filtration .....  | 41        |
| 4.1.1    | Contact filtration.....   | 43        |
| 4.1.2    | The Molde process .....   | 46        |
| 4.2      | Oxidation and biofiltration.....                                    | 48        |
| 4.3      | Ion exchange .....  | 51        |
| 4.4      | Adsorption / Activated carbon .....                                 | 53        |
| 4.5      | Membrane filtration .....   | 54        |
| 4.5.1    | General .....   | 55        |
| 4.5.2    | Separation mechanisms .....   | 57        |
| 4.5.3    | Membrane materials and structures.....                              | 58        |
| 4.5.4    | Module and process configurations.....                              | 60        |
| 4.5.5    | Membrane fouling .....  | 63        |
| 4.5.6    | Membrane processes relevant for treatment of Nordic waters .....    | 70        |
| 4.5.6.1  | Nanofiltration .....  | 70        |
| 4.5.6.2  | Low pressure membrane filtration: MF and UF.....                    | 72        |
| 4.5.6.3  | Low pressure membrane filtration with coagulation pre-treatment ... | 73        |
| 4.6      | Summary / comparison .....  | 80        |
| <b>5</b> | <b>Summary of experimental configuration and methods.....</b>       | <b>83</b> |
| 5.1      | Investigated process configurations .....                           | 83        |
| 5.2      | Ceramic membrane properties .....                                   | 85        |
| 5.3      | Raw water characterization.....                                     | 87        |
| 5.4      | In-situ floc characterisation.....                                  | 90        |
| 5.5      | Online DOC and colour measurements .....                            | 92        |
| 5.6      | PLS-regression.....   | 93        |
| <b>6</b> | <b>Published results .....</b>                                      | <b>97</b> |
| 6.1      | Publication 1 .....   | 97        |
| 6.2      | Publication 2 .....   | 115       |
| 6.3      | Publication 3 .....   | 131       |
| 6.4      | Publication 4 .....   | 159       |



|          |  |            |
|----------|--|------------|
| 6.5      | Publication 5 .....  | 185        |
| <b>7</b> | <b>Additional results .....</b>                                | <b>189</b> |
| 7.1      | Process performance without coagulation .....                  | 189        |
| 7.2      | Analogue vs. natural water .....                               | 190        |
| 7.3      | Comparison of PACl and non-polymerised AlCl <sub>3</sub> ..... | 193        |
| 7.4      | Summary and multivariate analysis of experimental data .....   | 195        |
| 7.4.1    | DOC removal.....   | 195        |
| 7.4.2    | Residual metal .....   | 198        |
| 7.4.3    | Irreversible fouling .....                                     | 201        |
| 7.4.4    | Reversible fouling .....                                       | 204        |
| <b>8</b> | <b>Conclusions .....</b>                                       | <b>213</b> |
| 8.1      | Revising hypotheses.....                                       | 213        |
| 8.2      | Suggestions for WTP design.....                                | 219        |
| 8.3      | Cost considerations .....                                      | 221        |
| <b>9</b> | <b>Suggestions for future work.....</b>                        | <b>225</b> |
| <b>A</b> | <b>Appendices .....</b>  | <b>229</b> |
| A.1      | Summary of DOC removal with PACl .....                         | 229        |
| A.2      | Supplemental modelling data.....                               | 231        |
| A.3      | Publication Overview.....                                      | 240        |
| A.4      | Sammendrag (Abstract in Norwegian) .....                       | 242        |
|          | <b>References .....</b>  | <b>245</b> |



# List of Figures

|   |    |
|---|----|
| Figure 1.1: Box charts of raw water quality parameters: turbidity, colour and pH-value of WTP's treating surface water, reported in 2009, based on data from The Norwegian Institute of Public Health (2010).....   | 2  |
| Figure 2.1: Floc trajectories of different sized flocs within the capillary (Lerch, 2008) .....   | 11 |
| Figure 2.2: Influence of different G-values on floc formation, adapted from Jekel et al. (2004).....  | 16 |
| Figure 3.1: Surface charge on a particle in water (Davis, 2010).....  | 20 |
| Figure 3.2: Potential energy diagram for the interaction of equal spheres with a diameter of 1 $\mu\text{m}$ in a solution of 1-1 electrolyte. The zeta potential of the particles is assumed to be 25 mV, and the Hamaker constant is $2 k_B T$ , after Gregory (2006) ..... | 21 |
| Figure 3.3: Speciation diagrams for Fe(III) and Al(III), only monomeric hydrolysis products are shown (Gregory, 2006). .....  | 24 |
| Figure 3.4: Mole fraction of hydrolyzed Fe(III) and Al(III) species relative to total soluble metal concentration (Gregory, 2006). .....  | 24 |
| Figure 3.5: Imagined structure of $AL_{13}$ , as monomer and polymerised, adapted from Gillberg et al. (2003).....  | 25 |
| Figure 3.6: Zones of destabilisation and resetabilisation at a given pH value as related to colloid concentration S and coagulant dosage C. (Adapted from Gillberg et al. (2003), based on Stumm and O'Melia (1968)). .....   | 29 |
| Figure 3.7: Schematic of floc formation after coagulating NOM with aluminium salts, adapted from Tambo et al. (1989) .....  | 33 |
| Figure 3.8: Modes of bridging between NOM and aluminium ions, adapted from Gregor et al. (1997).....  | 34 |
| Figure 3.9: Theoretical metal solubility at different temperatures and for different coagulants: a) alum and b) PACl (Pernitsky and Edzwald, 2006) .....  | 36 |

|   |    |
|---|----|
| Figure 3.10: Schematic of membrane filtration with sludge thickening .....  | 39 |
| Figure 4.1: Three filtration modes. (a) Inline filtration. (b) Direct filtration.<br>(c) Conventional filtration (Hendricks, 2006) .....  | 42 |
| Figure 4.2: Typical flow scheme for a contact filtration plant for NOM removal in<br>Norway including pH adjustment, corrosion control and disinfection,<br>adapted from Ødegaard et al. (1999) .....   | 43 |
| Figure 4.3: Treatment scheme of the Molde process, adapted from Hammersland (2009)<br>.....   | 46 |
| Figure 4.4: Schematic of an ozonation/biofiltration plant (Melin et al., 2002).....   | 49 |
| Figure 4.5: Schematic sketch of the OBM process, adapted from Azrague et al. (2009)<br>.....  | 50 |
| Figure 4.6: Typical flow diagram for an ion exchange treatment plant for the removal<br>of humic substances, adapted from Ødegaard et al. (1999).....   | 51 |
| Figure 4.7: Cumulated installed treatment capacity and number of plants using<br>membranes, from 1988 until 2006 (only plants with a total capacity of<br>>8m <sup>3</sup> /d, based on cumulated data from major membrane manufacturers). 55 |    |
| Figure 4.8: Schematic of separation process through a semi-permeable membrane<br>(Crittenden et al., 2005) .....  | 56 |
| Figure 4.9: Membrane types compared with scales for pore sizes and particles, after<br>Hendricks (2006) .....   | 56 |
| Figure 4.10: Mechanisms for rejection in membrane filtration: a) Straining, b) cake<br>filtration and c) Adsorption (Crittenden et al., 2005). .....  | 57 |
| Figure 4.11: Ultrafiltration cartridge with hollow fibres (courtesy of Koch Membrane<br>Systems, Inc.).....   | 61 |
| Figure 4.12: Different membrane configurations exemplary for hollow fibres (Crittenden<br>et al., 2005) .....   | 61 |
| Figure 4.13: Metawater's 3 <sup>rd</sup> generation monolith ceramic microfiltration membrane,<br>with 2000 channels and 25 m <sup>2</sup> surface area (courtesy of Metawater Co.,<br>Ltd., Japan) .....                                     | 63 |
| Figure 4.14: Different fouling mechanisms: a) pore blocking, b) pore constriction, c)<br>biological fouling and d) cake or gel layer formation (adapted from Melin<br>and Rautenbach (2004) and Crittenden et al. (2005)).....                | 64 |
| Figure 4.15: Schematic of partial restorations of TMP by normal or chemical enhanced<br>backwashing in a pressurised system operated in constant flux and dead-<br>end mode (Davis, 2010).....  | 68 |

|   |     |
|---|-----|
| Figure 4.16: Typical nanofiltration plant flow sheet (Machenbach and Thorsen, 2006)   | 71  |
| Figure 4.17: Schematic of the coagulation / UF surface water treatment plant in Lello, Levanger municipality, Norway, adapted from Sandvik and Ødegaard (2010)  | 79  |
| Figure 5.1: Schematic of all pre-treatment configurations investigated in this study: a) Conventional pre-treatment with rapid and slow mixing; b) Simplified conventional pre-treatment containing only a rapid mixing step; c) Inline coagulation with pipe flocculation, utilizing the membrane feeding pump as rapid mixer; d) Inline coagulation with static mixer and pipe flocculation | 84  |
| Figure 5.2: Ceramic microfiltration module and filtration pilot plant   | 85  |
| Figure 5.3: SEM pictures of the ceramic membrane used in this study, cross section (left) and membrane surface (right)  | 86  |
| Figure 5.4: Different stages of an operating cycle: a) filtration, b) backwash, c) air flush  | 86  |
| Figure 5.5: Organic carbon fractions in the analogue raw water used in this study, compared to natural lake water   | 88  |
| Figure 5.6: LC-OCD chromatograms of the analogue raw water, natural lake water and the Trondheim tap water (normalised to a DOC of 1 mg/L)  | 88  |
| Figure 5.7: LC-OCD chromatograms of different DOC fractions obtained from the analogue raw water (left column) and natural lake water (right column) showing the organic carbon signal (top row) and UV254 signal (bottom row)  | 89  |
| Figure 5.8: Processing of the photodiode signal: a) decomposition of the signal, b) amplified ac signal and <i>rms</i> derivation (Gregory and Nelson, 1986)  | 91  |
| Figure 5.9: The PDA 2000 and a schematic of the flow cell   | 91  |
| Figure 5.10: UV/Vis spectrum and examples of parameters derived out of this spectrum together with their characteristic absorbance profiles, S::CAN Spectrolyser (van den Broeke et al., 2009)  | 92  |
| Figure 5.11: Conceptual illustration of PLS regression (courtesy of CAMO Software Inc.)   | 93  |
| Figure 7.1: Typical TMP development for filtration without coagulation pre-treatment  | 190 |
| Figure 7.2: Irreversible and reversible membrane fouling in dependence on raw water type and pre-treatment setup  | 192 |

|  |     |
|--|-----|
| Figure 7.3: NOM removal and residual metal concentration in dependence on raw water type and pre-treatment setup.....  | 192 |
| Figure 7.4: Irreversible and reversible membrane fouling in dependence on coagulant type and pre-treatment setup.....  | 194 |
| Figure 7.5: NOM removal and residual metal concentration in dependence on coagulant type and pre-treatment setup .....   | 194 |
| Figure 7.6: Relative influence of predictors on the DOC removal. Summary of all data sets ( $R^2 = 0.77$ , $n = 155$ ). .....  | 196 |
| Figure 7.7: Relative influence of predictors on the DOC removal by PACl, comparing inline and tank pre-treatment and varying the flocculation time from 0 to 1260 s, the G-value from 4 to 1000 s <sup>-1</sup> and the coagulant dosage from 0.0063 to 0.024 mM Al per mg of DOC (based on Publication 4 and unpublished data, $R^2 = 0.86$ , $n = 79$ ). ..... | 197 |
| Figure 7.8: Influence of flocculation time on DOC removal ( $n_{total} = 61$ , pH = 6, flocculation G-values are varying from 12 to 1000). .....   | 198 |
| Figure 7.9: Relative influence of predictors on the residual metal concentration. Summary of all data sets ( $R^2 = 0.75$ , $n = 136$ ).....   | 199 |
| Figure 7.10: Influence of flocculation time on the residual metal concentration ( $n_{total} = 57$ , pH = 6, flocculation G-values are varying from 12 to 1000). .....   | 200 |
| Figure 7.11: Irreversible membrane fouling in dependence on the PACl dosage (tank coagulation pre-treatment, pH = 6, based on unpublished data) .....  | 201 |
| Figure 7.12: Relative influence of predictors on the irreversible fouling. Summary of data from the publications 1 and 4 and unpublished data ( $R^2 = 0.77$ , $n = 92$ ). .....   | 202 |
| Figure 7.13: Irreversible membrane fouling in dependence on the PACl dosage (tank coagulation pre-treatment, pH = 6, based on unpublished data) .....  | 203 |
| Figure 7.14: Influence of flocculation time on the irreversible fouling ( $n_{total} = 61$ , pH = 6, flocculation G-values are varying from 12 to 1000). .....   | 204 |
| Figure 7.15: Box chart of the reversible fouling distribution in dependence on the coagulation pre-treatment configuration (upper limit of Y-axis set to 500 for increased clarity, diamonds are representing the data mean, maximum value for inline coagulation at 1487, $n_{tank} = 25$ , $n_{inline} = 93$ ).....  | 205 |
| Figure 7.16: Influence of flocculation time on the reversible fouling ( $n_{total} = 61$ , pH = 6, flocculation G-values are varying from 12 to 1000). .....   | 206 |

|  |     |
|--|-----|
| Figure 7.17: State of aggregation shown as flocculation index in dependence on pre-treatment configuration and flocculation time (coagulation with 3 mg Al/L, G-value in inline configuration was $31 \text{ s}^{-1}$ , $n = 2$ ) .....                              | 207 |
| Figure 7.18: Relative influence of predictors on the reversible fouling. Summary of data from the publications 1, 2 and 4 and unpublished data ( $R^2 = 0.64$ , $n = 112$ ). .....   | 208 |
| Figure 7.19: Box chart of the reversible fouling after inline coagulation with FeCl (6 mg Fe/L) in dependence on the pH (based on Publication 2, $n = 24$ ) ..   | 209 |
| Figure 7.20: Relative influence of predictors on the reversible fouling. Summary of data from the publications 1 and 4 and unpublished data ( $R^2 = 77.6\%$ , $n = 91$ ). .....   | 210 |
| Figure 7.21: Reversible membrane fouling in dependence on the PACl dosage (tank coagulation pre-treatment, pH = 6, based on unpublished data) .....  | 210 |
| Figure 7.22: Reversible fouling after inline coagulation with FeCl in dependence on the G-value and pH (based on data from Publication 2 for a filtration flux of $143 \text{ L}/(\text{m}^2 \text{ h})$ , $n_{\text{total}} = 12$ ) .....                           | 211 |
| Figure 8.1: Frequency distribution plots of aluminium dosage to raw TOC concentration ratios (Archer and Singer, 2006).....  | 216 |
| Figure 8.2: Suggested scheme for a WTP with coagulation pre-treatment followed by ceramic MF .....   | 220 |
| Figure 8.3: Treatment costs in dependence on the specific membrane costs (assumptions: membrane flux: $143 \text{ L}/(\text{m}^2 \text{ h})$ , Mean/Max: 100%, interest loan: 5%, rate of price increase for ongoing costs: 0%) .....                                | 222 |
| Figure 8.4: Treatment costs in dependence on the membrane flux (assumptions: Mean/Max: 100%, specific membrane costs: $250 \text{ €/m}^2$ , interest loan: 5%, rate of price increase for ongoing costs: 0%) .....   | 223 |
| Figure 8.5: Treatment costs in dependence on the utilised plant capacity (assumptions: membrane flux: $250 \text{ L}/(\text{m}^2 \text{ h})$ , specific membrane costs: $250 \text{ €/m}^2$ , interest loan: 5%, rate of price increase for ongoing costs: 0%) ..... | 224 |
| Figure A-1: DOC removal with PACl in dependence on pH and specific coagulant dosage (based on all experiments carried out with Norwegian NOM concentrate, $n = 168$ ) .....  | 229 |
| Figure A-2: DOC removal with PACl in dependence on the specific molar coagulant dosage at pH 6 (based on all experiments carried out with Norwegian NOM concentrate and a coagulation pH of 5.8 to 6.2, $n = 100$ ).....   | 230 |

|  |     |
|--|-----|
| Figure A-3: Predicted versus measured plot for PLS modelling of DOC removal for regression results in Figure 7.6 (5 outliers, n = 155).....  | 231 |
| Figure A-4: Predicted versus measured plot for PLS modelling of DOC removal based in the experimental data from Publication 4 and unpublished data, comparing inline and tank coagulation, regression results are shown in Figure 7.7 (no outliers, n = 79)..... | 232 |
| Figure A-5: Predicted versus measured plot for PLS modelling of residual metal concentration for regression results in Figure 7.9 (6 outliers removed, n = 136).....   | 233 |
| Figure A-6: Predicted versus measured plot for PLS modelling of irreversible fouling for regression results in Figure 7.12 (2 outliers removed, n =92) .....   | 234 |
| Figure A-7: Predicted versus measured plot for PLS modelling of reversible fouling for regression results in Figure 7.18 (6 outliers removed, n =112).....   | 235 |
| Figure A-8: Predicted versus measured plot for PLS modelling of reversible fouling for regression results in Figure 7.20 (3 outliers removed, n = 91).....   | 236 |



# List of Tables

|             |   |    |
|-------------|---|----|
| Table 2.1:  | Variables in microfiltration with coagulation pre-treatment .....   | 7  |
| Table 2.2:  | Norwegian drinking water quality standards significant for this study .....   | 8  |
| Table 3.1:  | Frequently used metal coagulants (Davis, 2010).....   | 22 |
| Table 3.2:  | Reactions for hydrolysis of Al and Fe(III) and the formation of amorphous hydroxides, with their equilibrium constants (for 25°C and zero ionic strength), adapted from Gregory (2006)..... | 23 |
| Table 3.3:  | Composition of NOM and dependence on coagulation and DOC removal (Edzwald and Tobiason, 1999).....  | 30 |
| Table 3.4:  | Typically velocity gradients applied in water treatment (Bartel, 2002) .....  | 38 |
| Table 4.1:  | Minimum practical coagulant dose recommendations when using ALG, JKL or Chi in contact filtration of raw waters with colour levels of 15, 30 and 50 mg Pt/L (Eikebrokk et al., 2006). ..... | 44 |
| Table 4.2:  | Advantages and disadvantages of contact filtration .....  | 46 |
| Table 4.3:  | Advantages and disadvantages of the Molde process.....  | 48 |
| Table 4.4:  | Advantages and disadvantages of oxidation and biological filtration .....   | 51 |
| Table 4.5:  | Typical capacity parameter values for commonly used macroporous ion exchange resins (Ødegaard et al., 1989).....  | 52 |
| Table 4.6:  | Advantages and disadvantages of ion exchange.....   | 52 |
| Table 4.7:  | Advantages and disadvantages of adsorption .....  | 54 |
| Table 4.8:  | Typical preparation processes and raw materials of UF/MF membranes (Kubota et al., 2008) .....  | 59 |
| Table 4.9:  | Advantages and disadvantages of nanofiltration .....  | 72 |
| Table 4.10: | Advantages and disadvantages of low-pressure membrane filtration with coagulation pre-treatment .....   | 80 |

|   |     |
|---|-----|
| Table 4.11: Comparison of different treatment processes with respect to treatment of Nordic waters*                   | 81  |
| Table 7.1: NOM removal and membrane fouling without coagulant addition at a constant flux of 250 L/(m <sup>2</sup> h) | 189 |
| Table 7.2: Characteristics of natural lake water and the analogue   | 191 |
| Table 7.3: Summary of unpublished data included into the regression analysis  | 196 |
| Table 8.1: Assumed operational parameters   | 221 |

# Abbreviations

|        |  |
|--------|--|
| ALG    | Granular Aluminium Sulphate (Alum)               |
| BDOC   | Biologically Degradable Organic Carbon           |
| CA     | Cellulose Acetate                                |
| CCC    | Critical Coagulant Concentration                 |
| CLSM   | Confocal Laser Scanning Microscopy               |
| CSC    | Critical Stabilisation Concentration             |
| CEB    | Chemical Enhanced Backwash                       |
| CHA    | Hydrophilic Charged                              |
| Chi    | Chitosan   |
| CIP    | Cleaning In Place                                |
| DAF    | Dissolved Air Flotation                          |
| DOC    | Dissolved Organic Carbon                         |
| DON    | Dissolved Organic Nitrogen                       |
| EBCT   | Empty Bed Contact Time                           |
| EPS    | Extracellular Polymeric Substances               |
| FeCl   | Ferric Chloride                                  |
| F-EEM  | Fluorescence Excitation Emission Matrix          |
| FNU    | Formazine Nephelometric Unit                     |
| FTIR   | Fourier transform infrared spectroscopy          |
| FTU    | Formazine Turbidity Unit                         |
| GAC    | Granulated Activated Carbon                      |
| HOC    | Hydrophobic Organic Carbon                       |
| HRT    | Hydraulic Retention Time                         |
| IPCC   | Intergovernmental Panel on Climate Change        |
| JKL    | Iron chloride sulphate (Jernkolridsulfat)        |
| LC-OCD | Liquid Chromatography - Organic Carbon Detection |
| MF     | Microfiltration                                  |
| MWCO   | Molecular Weight Cut Off                         |
| NEU    | Hydrophilic Neutral                              |
| NF     | Nanofiltration                                   |
| NOM    | Natural Organic Matter                           |

|       |  |
|-------|--|
| OBM   | Ozonation Biofiltration Membranefiltration |
| PAC   | Powdered Activated Carbon                  |
| PACl  | Pre-polymerised Aluminium Chloride         |
| PC    | Principle Component                        |
| PLS   | Partial Least Square Regression            |
| PZC   | Point of Zero Charge                       |
| RMS   | Root Mean Squared                          |
| RO    | Reverse Osmosis                            |
| SHA   | Slightly Hydrophobic Acids                 |
| SDI   | Silt Density Index                         |
| SUVA  | Specific UV Absorption                     |
| TEM   | Transmission Electron Microscopy           |
| TMP   | Transmembrane Pressure                     |
| TOC   | Total Organic Carbon                       |
| TSUVA | Total Specific UV Absorption               |
| UF    | Ultra Filtration                           |
| UV    | Ultra Violet                               |
| VHA   | Very Hydrophobic Acids                     |
| WTP   | Water Treatment Plant                      |
| WWTP  | Waste Water Treatment Plant                |

# Introduction

## 1.1 Background

Surface water is a common water source for potable water production in countries with an abundance of water. In Norway for example, around 82% of the population are supplied with potable water from inland and mountain lakes, 8% from rivers and streams and 10% from ground water. In total, 90% of the population is served with water originating from surface water. As Norway is a sparsely populated country, the majority of its water treatment plants (WTP) are very small and often situated in remote locations. Around 50% of the WTPs have a treatment capacity lower than 10 m<sup>3</sup>/h and serve an average of 365 people. Another 40% of the plants have a capacity below 100 m<sup>3</sup>/h and only a handful of plants can actually treat more than 1000 m<sup>3</sup>/h, for example in the capital area of Oslo. The total number of registered treatment plants in 2009 was 1525. Especially at very small plants disinfection is not standard. In 2005, around 29,500 people in Norway were supplied with treated but undisinfected surface water from 137 WTPs, with an average supply of 215 inhabitants per plant (Myrstad et al., 2010).

The raw water quality from surface water sources can in general be characterized as having a low turbidity below 1 NTU, low alkalinity <0.5 meq/l, low hardness <5 mg Ca/L and elevated Natural Organic Matter (NOM) content, represented by typical colour values between 20 to 80 mg Pt/L and organic carbon concentrations between 3 and 6 mg C/L. Figure 1.1 shows raw water quality data reported by Norwegian WTPs treating surface water in 2009.

There is a growing concern regarding the increase of NOM in natural water sources, most likely a consequence of climate change. Several studies have shown that the

concentration of NOM in surface water may increase during the coming decades. Due to increased precipitation in parts of Scandinavia during the last 30 years, the drainage patterns in many catchments have changed, leading to an increased leaching of organic compounds from the upper forest floor to the lakes. In some areas a concentration increase of up to 50 % of colour and DOC has been reported for the period between 1983 and 2000/2001 (Forsberg, 1992; Hongve et al., 2004). This development is anticipated to continue since climate prediction scenarios forecast that the already high precipitation levels in Scandinavia will further increase in the coming decades. Based on scenario A1B<sup>1</sup>, defined by the Intergovernmental Panel on Climate Change (IPCC), the increase will be between 10 and more than 20% relative to precipitation levels observed in the period from 1980 to 1999 (IPCC, 2007). However, not only NOM concentrations might change due to altered flow patterns and higher fluxes, but also the composition, giving less degraded material at higher flow rates due to increased runoff is predicted to occur (Austnes, 2008). Future drinking water treatment facilities will therefore need to be able to deal with an increased frequency of extreme weather events.

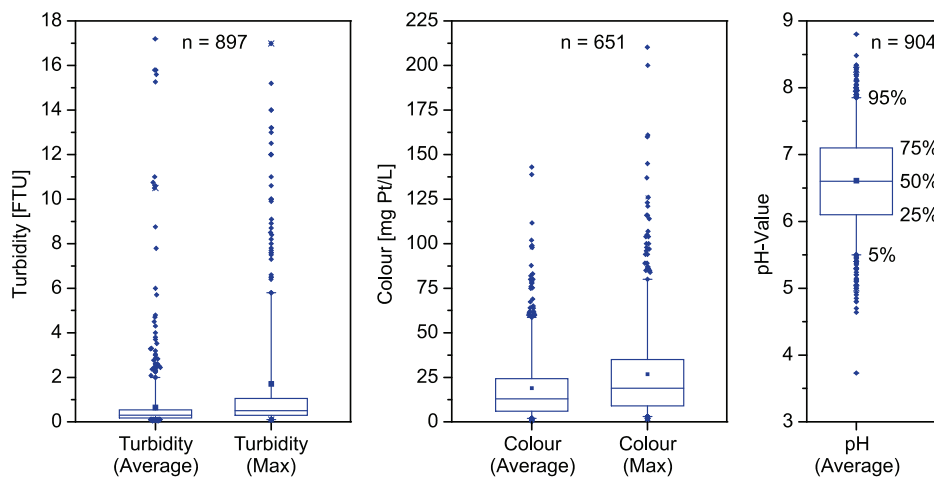

Figure 1.1: Box charts of raw water quality parameters: turbidity, colour and pH-value of WTP's treating surface water, reported in 2009, based on data from The Norwegian Institute of Public Health (2010).

During the last two decades low pressure membrane filtration, comprised of microfiltration (MF) and ultrafiltration (UF), has become an alternative standard treatment technology in the production of potable water. More and more full scale

<sup>1</sup> The scenario A1B describes a future world of very rapid economic growth, a global population that peaks in mid-century and declines thereafter, and the rapid introduction of new and more efficient technologies. Major underlying themes of this scenario are convergence among regions, capacity building and increased cultural and social interactions. Energy sources are based on a balanced mix of across all energy sources, fossil-intensive and non-fossil sources (IPCC, 2007).

applications for primary water treatment have been installed worldwide. By replacing conventional treatment steps (e.g. coagulation, sedimentation, and rapid filtration) with microfiltration a more reliable, robust, effective and cheaper treatment method is introduced. Compared to traditional treatment methods, additional advantages include a stable process under varying feed water quality, a smaller footprint, and highly automatic operation.

Even though the number of full scale installations applying polymeric membranes is increasing drastically, no such installations can be found with ceramic membranes in Europe, in spite of a number of successful membrane developers and producers for industrial purposes. Until recently, ceramic membranes have not been a competitive alternative compared to their polymeric counterparts due to higher investment costs, despite their promising physical properties. However, based on several pilot plant studies conducted in recent years, investigating the treatment of surface water with coagulation pre-treatment and ceramic microfiltration, this picture is changing (Lerch et al., 2005a; Loi-Brügger et al., 2006; Heijman and Bakker, 2007; Panglisch et al., 2010). It has been suggested that the operation of monolithic ceramic microfiltration membranes with appropriate pre-treatment, operated in constant flux and dead end mode, can be optimised in such a way that the process is competitive with the application of polymeric hollow fibre membranes. Higher flux may be obtained together with less frequent cleaning requirements for fouled membranes. Such assumptions in combination with the consideration of longer membrane lifetimes are the basis for this recent development.

## **1.2 Drinking water treatment perspectives**

The removal of NOM is one of the major concerns for potable water production in Norway and makes advanced drinking water treatment necessary. Although the main part of NOM is not harmful, some fractions like algogenic matter can cause colour, taste and odour problems, with some constituents even being toxic, such as the algae toxin microcystin. Specific fractions of NOM in drinking water can potentially lead to bacterial re-growth in the distribution system. Removal of NOM also reduces the load of following treatment steps and facilitates elimination of important trace compounds such as pesticides or heavy metals found in the NOM. Furthermore, these substances increase the necessary amount of disinfectants and are recognized as precursors for disinfection by-product formation, such as THMs which can be carcinogenic.

Another aspect, water hygiene, is of great concern in the production of potable water, where enteric pathogens in drinking water can cause diseases and acute infections and are able to survive for long term in the environment. Although enteric pathogens rarely debilitate healthy adults seriously, they can be critical to the health of young children

and the elderly, who often have compromised immune systems. In these cases, an infection can even lead to death, and several cases where bacteria and viruses have caused serious outbreaks have been documented in the past. Due to their low infection dose and low removal efficacy in conventional treatment processes, enteric viruses represent a particular health risk and their removal is a great challenge in the area of drinking water treatment technologies. Microfiltration is a robust treatment system against parasites such as *Giardia lamblia* and *Cryptosporidium parvum* as well as many bacteria. However other pathogens such as viruses are removed only to a small extent. Therefore coagulation pretreatment coupled with microfiltration is essential for providing high quality potable water that complies with hygienic requirements.

In a water situation as described for Norway in Chapter 1.1, treatment processes are required which can be easily operated in small and decentralised systems, as well as in larger, centralised installations. Therefore, technologies what can be constructed in a modular way, such as membrane filtration solutions would have a clear advantage. Another requirement for a modern treatment process is the energy consumption or CO<sub>2</sub> footprint. Since climate change is a scientific fact and the only question remaining is how hard it will strike, treatment processes should be applied which minimize environmental impacts and consume less energy and chemicals. They should also produce less waste. Microfiltration has most likely some advantages with regards to these issues, since they use lower pressures and thus less energy compared to alternative membrane processes (i.e. UF and NF). Due to the high expected permeate fluxes, less membrane area is necessary for treating the same amount of water. In addition, as it is assumed that the need for chemical cleaning does not increase, the overall consumption of chemicals can be reduced. Furthermore, no special detergents, wetting agents etc. are needed. However, the manufacturing process of ceramic membranes is rather energy intensive, a specificity which could possibly be balanced by higher operating fluxes and a longer membrane lifetime in a Life-Cycle-Assessment exercise. Nevertheless, ceramic microfiltration has strong potential to become a keystone for the treatment of Nordic waters.

The nature of typical raw water sources in Norway with regard to stability and potential for corrosion is also a matter of concern. A treatment concept for raw waters with low alkalinity, low hardness and low pH certainly has to include methods for corrosion control to avoid corrosion in the distribution network. As such, the main objectives for drinking water treatment in Norway are the efficient removal of high NOM concentrations, securing a hygienic and safe product to the consumers, and providing a stable, non-corrosive water supply in the distribution network.



### 1.3 Challenges

All membrane processes are subject to fouling, which reduces productivity and increases energy consumption, down time for maintenance, chemical usage, membrane replacement and so on. Fouling is a complex phenomenon which can be defined as the blockage of membrane pores during filtration caused by the combination of sieving and adsorption of particulates and compounds onto the membrane surface or within the membrane pores (Li et al., 2008). Feed water composition has a huge influence on this phenomenon. Parameters such as turbidity, TOC, the ultraviolet absorbance at 254 nm ( $UV_{254}$ ), as well as the polyhydroxyaromatic content, can be used for estimating the fouling potential of a raw water. Many other parameters have been investigated together with a variety of analytical techniques. Membrane fouling, however, was not fully describable or predictable by any of them.

The combination of coagulation with low-pressure MF membrane filtration has the potential of reducing many of the shortcomings encountered in conventional methods of NOM removal, e.g. coagulation/rapid media filtration and nanofiltration. MF membranes represent good barriers against bacteria and larger microorganisms, with virus retention depending mainly on the membrane. Due to excellent backwash ability along with high robustness, the investigated ceramic monolith MF configuration offers a promising method to counteract fouling. A lot of experience with surface water treatment and ceramic microfiltration has been accumulated for example in Japan. However, the treatment of low turbidity, low alkalinity, low buffer capacity water, with high DOC and colour content as found in the Nordic countries, has not been investigated in-depth.

In order to be a successful, integrated process, coagulation/ceramic microfiltration has to be operated in a way that a high permeate quality (i.e. low DOC and colour, pathogen free, no disinfection by-products, low residual metal) can be achieved simultaneously with a minimum of chemical and energy usage at low membrane fouling levels. Only then it can compete with established technologies.

### 1.4 Structure of thesis

**Chapter 2** presents the scope and rationale of the thesis. The combined process of coagulation and ceramic microfiltration is compared with two treatment processes conventionally used for the treatment of Nordic surface waters, rapid filtration and nanofiltration. General research questions and hypothesis are formulated.

**Chapter 3** gives a theoretical background of the water treatment unit processes coagulation and flocculation. Relevant coagulants are introduced and mechanisms

important for the removal of NOM are explained. Furthermore, the effects of low temperatures on coagulation are reviewed, since this is important for process application in Nordic countries.

**Chapter 4** reviews the different treatment technologies used in the treatment of Nordic surface waters, focusing on NOM removal. One emphasis lays on membrane technology, where the basic mechanisms are described, recent advances are presented and hybrid membrane systems are introduced.

**Chapter 5** gives an overview of the process configurations investigated and the ceramic microfiltration membranes applied. A more detailed characterisation of NOM in the raw water is given and selected analytical methods are described.

**Chapter 6** contains selected publications, four articles and one poster publication.

**Chapter 7** presents recent additional results, which have not been published yet. Furthermore, a summary of all results is shown, supported by data evaluation by PLS-regression in order to identify important process parameters and their influence on the process performance.

**Chapter 8** concludes the study with a reconsideration of the hypotheses. Recommendations for operating conditions and suggestions for WTP design are given. Some cost calculations are presented.

**Chapter 9** summarises suggestions for future research topics.

## Scope of thesis

### 2.1 Scope

This work presents an applied study on ceramic microfiltration with coagulation pre-treatment, suitable for surface waters with high organic carbon and colour content, and in addition low alkalinity, turbidity and buffer capacity. The raw water type used in this study is based on typical lake water found in Norway, which is commonly used as the source for potable water production. Commercially available coagulants based on iron and aluminium have been applied for the coagulation. A ceramic monolith microfiltration membrane, operated in dead-end inside-out mode, was the basis of the separation step. Such a treatment setup involves many different independent variables, which directly or indirectly affect the treatment efficiency and the treated water quality. Table 2.1 identifies the main operating parameters and system responses addressed in this study.

Table 2.1: Variables in microfiltration with coagulation pre-treatment

| Pre-treatment           | Membrane separation | System responses       |
|-------------------------|---------------------|------------------------|
| Coagulant type and dose | Filtration flux     | DOC and colour removal |
| Coagulation pH          | Backwash frequency  | Membrane fouling       |
| Flocculation conditions |                     | Residual metal         |
|                         |                     | Virus removal          |

One major research objective was the establishment of reasonable operating conditions and the evaluation of the process performance in dependence on them. As a starting point, publications about direct surface water treatment with similar membranes have been considered, a field in which this process combination has been applied successfully. However, no experiences have been available with regard to treatment of

surface water in Nordic countries. The second goal of this work was to investigate the influence of the main process variables (Table 2.1) and their interdependencies on the system performance. However, the focus has been on the coagulation pre-treatment and the impact this has on the membrane filtration stage. Based on the outcomes of the study, the ambition was to formulate operating conditions which allow stable and efficient operation of the complete treatment train. From these recommendations the aim is to enable a comparison of the investigated treatment scheme with conventional processes with respect to treatment efficiency and overall performances.

## 2.2 Rationale

As described in the introduction (Chapter 1), the majority of the population in Norway is served with treated surface water from inland or mountain lakes. Due to climatic conditions, this water is generally characterized by low turbidity, low alkalinity, low hardness, but with high organic carbon content and colour levels. In order to comply with Norwegian and European drinking water standards, NOM has to be removed from the raw water. If coagulation is applied in a treatment scheme, more stringent legal limiting values apply. Once a coagulation treatment process complies with these limits, it is assumed that this process is operated in a satisfactory manner, and it further can be considered as a hygienic barrier. A selection of such limiting values is shown in Table 2.2. The drinking water guidelines demand for example that the colour has to be reduced below 5 mg Pt/L if coagulation with metal salts is used, and the TOC below 3 mg C/L respectively (Norwegian Ministry of Health and Care Services, 2001).

Table 2.2: Norwegian drinking water quality standards significant for this study

| Parameter | Unit    | Drinking water guidelines | Indication for good operation <sup>1)</sup> | If Al or Fe is used as coagulant <sup>2)</sup> |
|-----------|---------|---------------------------|---|--|
| Turbidity | FNU     | 1 <sup>3)</sup>           | 0.2   |  |
| Colour    | mg Pt/L | 20                        | 10  | 5  |
| TOC       | mg C/L  | 5 <sup>4)</sup>           | 3   |  |
| Aluminium | mg/L    | 0.2                       | 0.15  |  |
| Iron      | mg/L    | 0.2                       | 0.15  |  |

<sup>1)</sup> Compliance indicates good operation practise and is necessary in order to be approved as hygienic barrier

<sup>2)</sup> Compliance is necessary if coagulation with aluminium or iron is applied

<sup>3)</sup> Measured in the effluent of the WTP, at the consumer's side the limit is 4 FNU

<sup>4)</sup> Does not have to be monitored if WTP produces less than 10,000 m<sup>3</sup>/d

Regulations further specify that a water supply system must be equipped with at least two hygienic barriers. Such a barrier is defined as a "Natural or constructed physical or chemical obstacle, which removes, neutralizes or kills bacteria, viruses, parasites etc., and/or dilutes, decomposes or removes chemical or physical substances to a degree that

these substances no longer represent a health risk.” (Norwegian Ministry of Health and Care Services, 2001). In order to be approved as hygienic barrier, a treatment step has to remove 99.9% (3-log units) of bacteria and viruses and 99 % (2-log units) of parasites. Guidelines list the following processes as possible hygienic barriers: chlorination, UV-radiation, ozonation, membrane filtration and coagulation (chemical precipitation). The two most common processes for treatment of surface water with elevated NOM content in Norway are coagulation/rapid media filtration and direct nanofiltration (Ødegaard et al., 2010). As previously mentioned, if a coagulation process shall act as a hygienic barrier, the more stringent limiting values shown in Table 2.2 apply. With regard to direct membrane treatment, only regulations for cross-flow membranes are specified at the moment. The current requirement in order to be considered as a hygienic barrier against all types of microorganisms is a maximum pore size of 10 nm and a sufficient cross flow velocity. The microfiltration membranes used in this study, having a nominal pore size of 100 nm, are only a sufficient barrier against larger organisms, such as bacteria, bacteria spores and parasites and therefore do not fully comply with the hygienic barrier definitions. However, if the membranes are coupled with coagulation, different rules apply.

Low pressure membrane processes have emerged in the recent decades and are now considered standard technology. At the beginning of 2007, about 750 plants with a capacity higher than 8 m<sup>3</sup>/h, having a total production capacity of around 9,000,000 m<sup>3</sup> per day, were in operation around the world using this technology. However, most of these plants are designed for the removal of turbidity and microorganisms. In contrast, the main focus in Norway is on the treatment of low turbidity water with high NOM content. Even though successfully applied in other parts of the world, not much experience has been accumulated in the treatment of such waters using a hybrid system which combines coagulation pre-treatment and membrane microfiltration.

As described in Chapter 1.3, the coagulation/rapid media filtration and direct nanofiltration conventionally used in Norway today, have proven to be a reliable treatment alternative for potable water production. However, the disadvantages and challenges commonly stated for these systems can most likely be tackled by low pressure ceramic microfiltration coupled with coagulation pre-treatment, as explained in the following sections.

### 2.2.1 Why monolith ceramic membranes?

Ceramic membranes have a long history on the membrane market. In most cases they have been applied in industries where high membrane integrity under harsh operating conditions, such as high temperatures or chemically aggressive environments, is necessary. In the last two decades, however, they have slowly been entering the water

sector. Even though they are more expensive than their polymeric counterparts, they offer a variety of advantages which might justify the greater investment.

Ceramic membranes can be distinguished by excellent mechanical strength and a very high breaking stress. However, they are brittle and not very flexible, which can be a challenge when handling the modules. Furthermore, ceramic membranes are considered to be very stable against temperature and aggressive chemicals and can even be operated under numerous conditions in which polymeric membranes have difficulties. However, they are not conducive to all imaginable conditions. Depending on the quality of their base material, many ceramic membranes may have difficulties at high pH values, for example, where they start to deteriorate. Ceramic membranes typically have a very homogeneous pore size distribution and a higher permeability compared to polymeric membranes with similar molecular weight cut off (MWCO) (Lee and Cho, 2004). The pure water flux of the membranes used in this study was measured to be  $42.9 \pm 3.8 \text{ m}^3/\text{m}^2/\text{d}$  at a pressure of 1 bar and 25°C. Furthermore, permeability loss observed in the experiments was always reversible using chemical cleaning with acid and sodium hypochlorite. Due to the excellent stability of ceramic membranes, long lifetimes are assumed for the type of application investigated in this study. Manufacturers normally give a warranty of 12 years, however, longer lifetimes can probably be expected.

The monolith design and operation in dead-end and inside-out configuration has a number of advantages compared to other membrane system designs. Such modules with tubular channels can cope with high particulate loadings, which is the case when treating raw waters with coagulant demand, as long as the particles are not too large compared to the channel diameter. Thin flow channels due to dense packing densities are prone to clogging, which is thus avoided. Furthermore, the channels in a monolith membrane have excellent backwashing hydraulics. Backwashes are commonly performed using permeate and pressurized air. There are no dead zones or sludge pockets as for example found in hollow fibre outside-in configurations. Another advantage for the application of multichannel membranes with coagulation lies in the consideration that the 1 meter long and 2.5 mm wide membrane channels have such a flow pattern, that they can work as a pipe flocculator themselves. Floc development is further supported and promotes a dense columnar cake layer at the dead-end points, but alleviates cake layer formation on the rest of the membrane surface (Yonekawa et al., 2004). Lerch published similar results, where flocs of a size smaller than a certain limiting radius were found to be deposited widely homogeneous over the total capillary length of the channel (Lerch, 2008). However, larger flocs occupied preferential places on the membrane surface and did not deposit until they were at a certain distance to the capillary inlet. The larger the particle size, the longer this distance. This interrelation is shown in Figure 2.1 for different sized flocs.

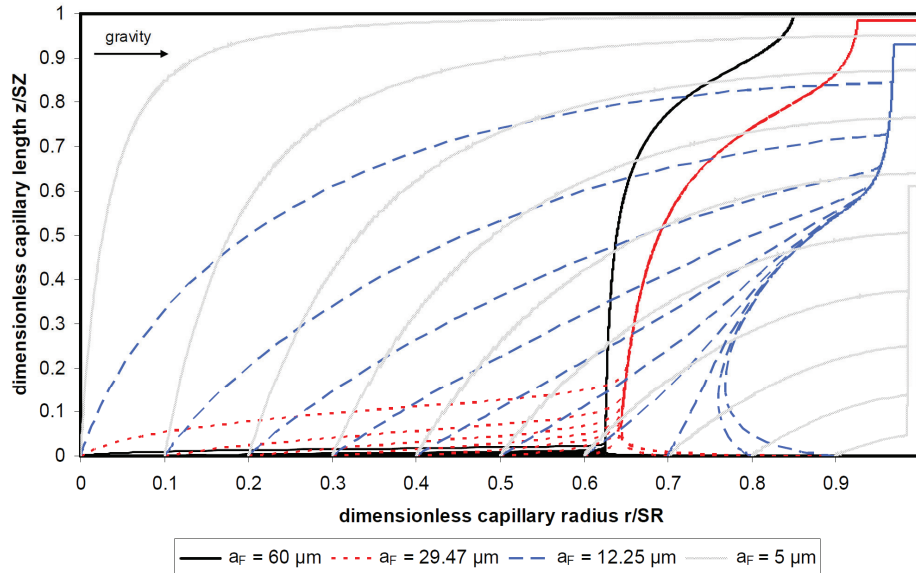

Figure 2.1: Floc trajectories of different sized flocs within the capillary (Lerch, 2008)

Lerch stated that “flocs with radii larger than a limiting radius will be forced to travel along merging trajectories and finally in a resulting equilibrium trajectory until being deposited. With increasing floc size this will lead to a point where all incoming flocs, independent of their radial starting position at the capillary inlet, will be forced to merge this trajectory.” (Lerch, 2008). As a result, flocs will be brought into very close and assumable unavoidable contact to each other and floc aggregation by some kind of orthokinetic aggregation might occur, leading to larger floc aggregates. Furthermore, considering a polydisperse size distribution of flocs accompanied with their different trajectories during transport, an increase in collisions rate, i.e. the number of collisions of flocs, can be furthermore assumed due to crossing and/or constriction of trajectory bundles as shown in Figure 2.1.

### 2.2.2 Coagulation-MF compared to conventional processes

As mentioned in the introduction, two processes dominate for surface water treatment in Norway, different forms of rapid media filtration and direct nanofiltration.

**Rapid filtration** is often applied without additional settling and flocculation steps, as contact filtration. Aluminium or iron based coagulants are normally used. Sometimes polymers are added as a filter aid. A detailed description of rapid filtration is given in Chapter 4.1. A replacement of rapid filters with a microfiltration membrane has the following advantages:

- a) **Increased hygienic barrier.** Independent from the pre-treatment, microfiltration is able to remove bacteria, bacterial spores and parasites below the detection limit (United States Environmental Protection Agency, 2001). Differing from rapid filtration, even if coagulation pre-treatment fails due to theoretical reasons, the removal of these pathogens is still ensured. If operated under optimal coagulation conditions, parasites are effectively removed (>3 log) when water of low turbidity was produced (Nieminski and Ongerth, 1995). However, the disadvantage lies in the case of a coagulation error, after which the removal will be poor. Thus, in this circumstance, viruses are poorly removed by microfiltration membranes. Typically, virus removal in the range of 0.2 to 2 log units has been found, just by the microfiltration membrane (Jacangelo et al., 1995; Zhu et al., 2005). Coupled with coagulation, removal rates higher than 4 log units are achievable, depending on the operating conditions and type of virus. Nonetheless, membrane integrity is an issue of concern since membranes can only act as a barrier as long as they are physically intact.
- b) **Constant permeate composition.** The microfiltration permeate quality is very stable during a filtration cycle, even with coagulation pre-treatment, since particles or flocs are continuously retained. The permeate quality is certainly effected by different removal mechanisms on the membrane surface, such as cake layer development, but the changes these provoke are rather small. Permeate quality is further not affected by membrane backwashes. In contrast, the effluent quality of a rapid filter strongly depends on the stage of operation and the operating conditions, such as pH, coagulant dose and filtration rate. In the initial ripening period after a backwash and at the end of a filtration cycle, as the breakthrough starts to occur, particle and pathogen removal performance may deteriorate. Emelko et al. (2003) stated that relative to stable operation, substantial deterioration in *C. parvum* removal can occur during early and late breakthrough filtration. As a consequence, they suggested that placing filters out of service prior to reaching a common level of filter effluent turbidity is one operational strategy for maximizing *C. parvum* and potentially other pathogen removal by filtration.
- c) **Smaller footprint.** Depending on manufacturer and operating conditions, membranes can have a significantly smaller floor space demand compared to media filters. If just the filtration units are compared, space savings by a factor of 2 to 8 are possible.



- d) **Simpler backwash procedure.** The backwash procedure of rapid media filters is subject to constant optimisation and ongoing research, since it influences the filter operation as a whole. Backwashing a rapid filter is rather time consuming, considering the backwash itself and filtration against waister in the ripening period, it typically lasts several minutes. In comparison, the backwash procedure of the membrane system used in this study is in the range of seconds. A concomitant phenomenon of rapid filtration, such as loss of filter material, does not occur if membranes are used instead. However, increased system complexity due to chemical enhanced backwashes (CEB) or production losses due to cleaning in place (CIP) procedures should be taken into account for an overall treatment scheme comparison, if membranes are used.
- e) **Higher degree of automation.** Membrane processes can be operated fully automatically, whereas rapid filtration requires more involvement and supervision of an operator.

**Nanofiltration** is the second conventional process used for NOM removal in Norway. More than 100 plants of different sizes are in operation today, commonly equipped with cellulose acetate (CA) membranes with a nominal pore size 1-5 nm. A detailed description of nanofiltration is given in Chapter 4.5.6.1. The replacement of nanofiltration by microfiltration has the following advantages:

- a) **Less membrane area needed due to significantly higher fluxes.** Installations with ceramic microfiltration membranes typically operate with a flux of 120 to 180 L·m<sup>-2</sup>·h<sup>-1</sup>. Experiments presented in this work have been carried out at fluxes up to 250 L·m<sup>-2</sup>·h<sup>-1</sup>. In contrast, nanofiltration plants are operated at sustainable fluxes of 15-17 L·m<sup>-2</sup>·h<sup>-1</sup> (Thorsen, 1999). Therefore, microfiltration plants can be design much more compact, where the same amount of water is treated by fewer membranes.
- b) **Lower energy consumption.** The spiral wound nanofiltration membranes are normally operated at a pressure of 3 to 6 bar. In order to maintain sufficient cross flow, a large amount of concentrate has to be recycled, where the recirculation flow is in the same range as the feed flow. Consequently, a lot of energy is used for pumping. In comparison, low pressure microfiltration operates at pressures up to one bar.
- c) **Higher water recovery.** Nanofiltration plants designed for colour removal are usually operated at recovery rates below 70% (Ødegaard et al., 2010).

Microfiltration however, usually accomplishes recoveries higher than 90% and is thus more efficient.

- d) **Less fouling with less chemical use.** Nanofiltration plants in Norway have suffered in the past from capacity loss over time, often due to too high design fluxes relative to the raw water characteristics. Another typical reason for rapid fouling are seasonal changes in the raw water quality. In order to prevent fouling, the membranes have to be cleaned chemically, since the spiral wound modules are not backwashable. In practice a CIP is done once a day during the night time using acidic and caustic detergents as well as chlorine, and lasts for 1-2 hours. Depending on the procedure, the volume of waste generated during a CIP corresponds to 0.2 to 0.5% of the produced permeate volume. A couple of times per year, a main cleaning is carried out. In contrast, monolith ceramic membranes are well backwashable with permeate. Chemicals may be dosed into the backwash water, i.e. acid or caustic, in order to increase the backwash efficiency. If due to different reasons the membrane capacity is reduced, in spite of regular backwashing, CIP procedures with more concentrated chemicals can be performed very easily since the membrane is very resistant against chemicals. Therefore, permanent capacity losses are not a problem. However, the additional coagulation process should be taken into consideration, since Nanofiltration treats the water directly.

### 2.3 General research questions and assumptions

With respect to this study, the following general research questions are the basis for formation of the hypotheses, research objectives and the rationale of the work undertaken. The main questions include:

- A) Is the hybrid process of coagulation/ceramic microfiltration suitable for drinking water treatment of source waters with very low turbidity but with high coagulant demand (i.e. due to high NOM content)?
- B) To what degree does a higher coagulant demand influence the filtration efficiency compared to the treatment of raw water with high turbidity but low NOM content? What is the impact on filtration cycles, membrane fouling, membrane backwashing procedures, membrane cleaning, and membrane operating parameters in general?
- C) Is clogging of the membrane channels a problem for high coagulant demand waters, and if so, at which operating conditions is the impact greatest?

- D) What is the impact of the degree of flocculation on the overall process performance, NOM removal and membrane fouling? Is a conventional design of the coagulation/flocculation stage also suited for membrane filtration processes or can this be optimized?
- E) Is the process sensitive to different types of coagulants? Are there any advantages or disadvantages with different coagulants?
- F) What are reasonable operating conditions and treatment capacities of the hybrid system?
- G) Can the hybrid process of coagulation/ceramic microfiltration comply with all drinking water standard requirements, in particular the potential of fulfilling requirements to meet hygienic barrier demands (i.e. virus removal)?

During all performed experiments no chemically enhanced backwashes (CEB) were carried out. Such backwashes most likely improve the membrane performance by reducing the irreversible fouling. However, the goal of the research was not the optimization of operation under certain operating conditions, but the optimization of the operating conditions themselves. In light of developing a sustainable treatment scheme demonstrating that the treatment concept works without CEB is foreseen as being an added benefit.

## 2.4 Hypotheses

The following hypotheses are therefore the basis for the investigations, experimental design and approach to this study:

- A) Without coagulation NOM removal by microfiltration membranes is poor, with a potential of rapid membrane fouling by organic matter.**

Molecule sizes of NOM are smaller than the nominal pore size of 100 nm of the microfiltration membrane. Therefore, it is assumed that most of the NOM is able to permeate the membrane. However, since there are also bigger particles in the raw water, although in low concentrations, a deposition layer may form over time. As a consequence the transmembrane pressure (TMP) may increase with time. Assuming the formation of a coating layer which is not very well backwashable, i.e. compared to a cake consisting of developed flocs, this TMP increase might not be reversible. Another possibility for fouling development would be direct interaction of some particular NOM fractions with the membrane surface.

**B) Coagulation/flocculation pre-treatment is a requisite with membrane micro-filtration for sufficient NOM removal when treating raw water with high NOM content and low turbidity.**

Two main reasons support the application of coagulation/flocculation in this case. Dissolved NOM can be coagulated and flocculated. This may significantly improve the DOC and colour removal by the MF membrane. Membrane fouling will be reduced since formed agglomerates have sizes much larger than the pore size of the membrane. Furthermore, NOM compounds which are known as membrane foulants may be rendered inactive by coagulation, since the formed agglomerates have different physical and chemical properties compared to a state where these components are in solution or dispersed. Coagulation may consequently minimize interactions of NOM with the membrane surface.

**C) Due to separation properties and mechanisms of microfiltration membranes, very small particulates can be removed, thereby reducing the amount of flocculation necessary for efficient particle removal. However, a minimum of flocculation is necessary in order to reduce membrane fouling by colloidal material.**

The size of flocs formed in a flocculation processes strongly depends on the applied conditions. Increasing flocculation time leads to a bigger floc size. However, for each flocculation system a maximum floc size can be assumed, depending on the shear force applied to the system. The higher the applied shear is, the smaller the maximum achievable floc size will be, as shown in Figure 2.2. Increased flocculation time allows primary particles to flocculate, resulting in lower particle numbers. These relationships are believed to have a direct influence on the filtration performance and thus, membrane fouling.

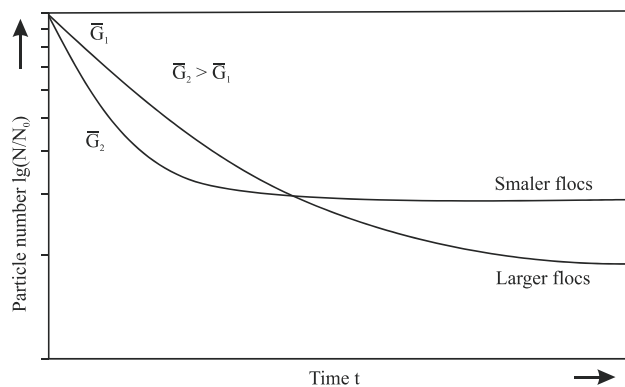

Figure 2.2: Influence of different G-values on floc formation, adapted from Jekel et al. (2004)

**D) Both, polyaluminium chloride and iron chloride commonly used in drinking water treatment are suitable coagulants. Optimum coagulant dosages are in the same range as those used for conventional treatment processes. However, there is a potential for using lower dosages.**

Polyaluminium chloride and iron chloride are widely and successfully used in water treatment, also for pre-treatment purposes for membrane filtration. However, they may differ in coagulation kinetics and as a result, may produce flocs of different characteristics. This would directly influence the filtration performance of the membrane unit. In order to remove sufficient amounts of NOM sufficient coagulant is necessary. It is therefore expected that optimal coagulant dosages for this process correspond to coagulant dosages normally applied in practise, i.e. for rapid filtration. However, if it is assumed that the final floc size depends beside other parameters also on the coagulant dosage (Gillberg et al., 2003), there may be a possibility to further reduce that dosage, since the microfiltration membrane has a very small pore size and thus large flocs are not a necessity for sufficient particle retention. Nevertheless, there may be a minimum practical dosage below which the coagulation will not be efficient, resulting in high residual metal concentrations (Eikebrokk, 1996).

**E) If coagulation is occurring in agreement with good operational practise, and thus the criteria for approval as hygienic barrier are met, efficient virus removal is achieved.**

Process performance parameters such as effluent turbidity, TOC, colour and residual metal concentration have been identified as indicators for good operating practise of a coagulation process, as described in Chapter 2.1. If these parameters comply with certain limiting values, the process under investigation can be considered as a hygienic barrier. Therefore, virus removal should be sufficient under such conditions. However, it should be noted that the high NOM concentrations and low turbidity in the raw water may hamper the virus removal.

**F) Due to both, different flocculation needs for membrane microfiltration and the expectation of sustainable fluxes to be high, the hybrid coagulation/flocculation microfiltration process creates the potential for new and more compact treatment designs and configurations compared to direct filtration and nanofiltration.**

It is assumed that only little flocculation is necessary in order to produce aggregates large enough for sufficient retention by the membrane, due to the small pore size. This is different for other processes such as rapid sand filtration, where a certain level of flocculation is necessary, even though this can happen in the filter head or even within

the filter bed. However, overall we believe that the flocculation pre-treatment can be designed more compact for the system investigated in this study. If it is further possible to achieve similar high fluxes as have been reported in the literature for the treatment of surface water, containing less NOM but more turbidity, with ceramic microfiltration, also the filtration unit could be designed much more compact, not only the pre-treatment step.

**G) Coagulation/flocculation coupled with ceramic microfiltration is very well suited for the treatment of typical Nordic surface waters and can readily compete with conventional processes with respect to treatment efficiency, water quality produced, with the potential of reducing sludge/waste production, energy requirements and overall costs.**

As described in Chapter 2.2, there are various advantages connected with the application of ceramic membranes alone, but also in combination with coagulation/flocculation pre-treatment. If high fluxes can be maintained, in spite of the high coagulant demand of the raw water, the investigated treatment is likely to be more efficient compared to conventional processes on the market.

## 2.5 Specific research objectives

The specific research objectives of the study include:

- Conduct an extensive review and state-of-the-art report on chosen technologies
- Investigate and assess commercially available coagulants commonly used in drinking water treatment with respect to use in the hybrid treatment process studied
- Determine optimal coagulant dosages and reasonable operating conditions for the coagulation / flocculation pre-treatment stage
- Investigate and assess low-pressure ceramic MF processes for drinking water production with respect to treatment efficiencies and overall membrane performance
- Investigate and assess alternative process design criteria for optimised system performance, in particular alternative flocculation designs and the impact this has on overall treatment efficiencies
- Investigate and assess the treatment scheme with respect to capability of fulfilling hygienic barrier requirements, with an emphasis on virus removal
- Determine and formulate operating conditions which allow stable and efficient operation of the complete treatment train

## Coagulation and flocculation

With a long history of applied usage, coagulation and flocculation are probably among the most widespread unit processes in potable water treatment. Around 2000 BC the Egyptians used almonds smeared around a vessel to clarify river water. Flocculation was achieved by plunging an arm into the liquid. Additionally, the use of alum as a coagulant by the Romans can be found in citations ca. 77 AD.

In this work, coagulation is defined as the process of destabilization of a given suspension or solution, or with other words, to overcome the stability of a given system by coagulation. Flocculation is the process whereby destabilized particles or particles created by destabilization, are promoted to come together and make contact, in order to form larger aggregates. These are then readily removed in subsequent processes such as settling, dissolved air flotation (DAF), rapid- and membrane filtration.

### 3.1 Surface chemistry

Small particulates and colloidal matter found in natural waters have a large specific surface area and are therefore an important factor for many processes that take place in the water phase, such as adsorption, desorption, ion exchange, complexation, precipitation, and crystallisation. These particles have a surface charge, which is negative most of the time. This charge arises in four principal ways according to Stumm and Morgan (1970):

- *Ionisation*. For example, silica has hydroxyl groups on its exterior surface. Depending on the pH, these can accept or donate protons.
- *Adsorption*. A solute becomes bound to the solid surface in this case, i.e. humic acid molecules on a silica surface. Humic acids have carboxylic acid groups that can then dissociate, in dependence on pH.

- *Isomorphous replacement.* Under geologic conditions, the metal in a metal oxide is replaced by another metal atom with a lower valence.
- *Structural imperfections.* In the formation of the mineral crystal, bonds are broken on the edge of the crystal.

The charge of the particles is compensated by counter ions in the surrounding water phase, leading to the development of an electrical double layer as shown in Figure 3.1. Ions directly attached to the particle surface build the inner Helmholtz layer. After that, hydrolysed ions with opposite charge attach, creating the outer Helmholtz layer. Beyond that, the loose diffuse layer starts to form. The ions move freely due to Brownian motion in this layer, but have a high statistical probability to remain close to the colloid. Inner and outer Helmholtz layer summarized together are also called Stern layer. They have a thickness of around 0.5 nm. The double layer (Stern plus diffuse layer) has a net negative charge over the bulk solution. Depending on the solution characteristics, it can extend up to 30 nm into the solution. The electrostatic potential gradient from the particle surface to the end of the diffuse layer can be calculated based on the Poisson-Boltzmann relationship (Elimelech et al., 1995). However, the only measurable parameter is the Zeta potential  $\xi$ , the electric potential at the shear plane by electrophoresis.

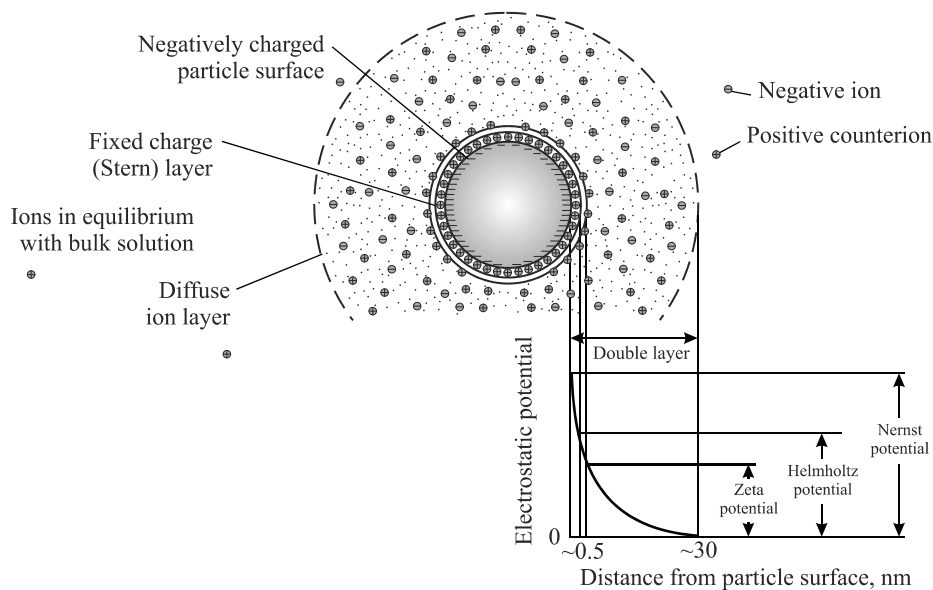

Figure 3.1: Surface charge on a particle in water (Davis, 2010)

Particles in water are subject to different electrostatic interactions, which influence each other. Attracting Van der Waals forces arise from magnetic and electronic resonance when two particles approach one another. They are very weak compared to electrostatic



forces and dominate only in short distances. Other forces are interactions caused by hydration, hydrophobic interactions and steric interactions.

The DLVO theory, named after the four developers Derjaguin and Landau, and Verway and Overbeck respectively, is commonly used to describe the behaviour of colloids in aqueous phases. By overlaying Van der Waals forces and electrostatic interactions, the DLVO theory describes the total interactions between particles approaching each other. Depending on the distance between the particles, a primary and a secondary energy minimum can be observed as visualised in Figure 3.2 a).

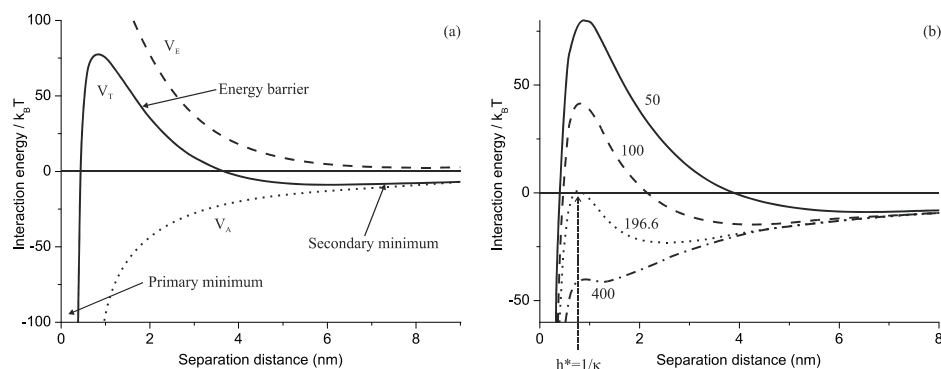

(a) Electrical ( $V_E$ ), van der Waals ( $V_A$ ) and total ( $V_T$ ) interaction energy in a 50 mM electrolyte solution

(b) The effect of electrolyte concentration and total interaction energy (mM electrolyte conc. are shown on the curves)

Figure 3.2: Potential energy diagram for the interaction of equal spheres with a diameter of 1  $\mu\text{m}$  in a solution of 1-1 electrolyte. The zeta potential of the particles is assumed to be 25 mV, and the Hamaker constant is 2  $k_B T$ , after Gregory (2006)

Particles in the secondary minimum show merely weak binding forces and can be separated again very easily. A further approach is only possible if the repulsing energy barrier can be overcome and the area of the primary energy minimum can be reached. In that area, the Van der Waals forces dominate the electrostatic repulsion forces and a strong adhesion can occur. For distances greater than 3 nm, the DLVO theory was experimentally confirmed. However, at shorter distances, serious deviations from the theory were observed, due to the neglect of hydration effects and contact forces as well as a result of steric effects and the influence of  $\text{Ca}^{2+}$  as a bridging component (Gregory, 2006).

According to the DLVO theory, the energy barrier depends on the ionic strength in a solution. With increasing concentration of counter ions the double layer thickness

decreases. The energy barrier can further totally disappear, and only Van der Waals forces then have an effect, as shown in Figure 3.2 b). The efficiency of counter ions increases with increasing valence.

Due to the chemical adsorption of ions, stabilising or destabilising effects can be observed, depending on ion type and charge. The formation of dative bonds between  $\text{Ca}^{2+}$  or  $\text{Mg}^{2+}$  and  $\text{OH}^-$  or carboxylic functional groups from adsorbed organic matter can reduce the negative particle charge and hence, reduce repulsion (Stumm and Morgan, 1970). Destabilizing colloids in aqueous phases by neutralizing electrical negatively charged particle surfaces is a central mechanism in coagulation and is realized in practise by dosing trivalent iron or aluminium species.

## 3.2 Coagulants

Coagulants are chemicals added to a suspension or solution to achieve destabilisation. In contrast, flocculents or filter aids are chemicals or substances added to a destabilized suspension or solution in order to accelerate the flocculation rate and / or to modify the properties of the flocs formed by flocculation. Commonly used in practise are metal coagulants, and polymers.

### 3.2.1 Metal based coagulants

The most widely used coagulants are based on aluminium and iron salts. Typical examples include aluminium sulphate, also known as “alum”, and iron chloride. Table 3.1 gives an overview of frequently used metal coagulants.

Table 3.1: Frequently used metal coagulants (Davis, 2010)

| Coagulant               | Chemical formula  | Molecular weight, g/mole |
|-------------------------|---|--------------------------|
| Aluminium sulphate      | $\text{Al}_2(\text{SO}_4)_3 \cdot 14\text{H}_2\text{O}$ | 594                      |
| Sodium aluminate        | $\text{Na}_2\text{Al}_2\text{O}_4$                      | 164                      |
| Aluminium chloride      | $\text{AlCl}_3$   | 133.5                    |
| Poly-aluminium chloride | $\text{Al}_w(\text{OH})_x(\text{Cl})_y(\text{SO}_4)_z$  | Variable                 |
| Poly-aluminium sulphate | $\text{Al}_w(\text{OH})_x(\text{Cl})_y(\text{SO}_4)_z$  | Variable                 |
| Poly-iron chloride      | $\text{Fe}_w(\text{OH})_x(\text{Cl})_y(\text{SO}_4)_z$  | Variable                 |
| Ferric chloride         | $\text{FeCl}_3$   | 162.5                    |
| Ferric sulphate         | $\text{Fe}_2(\text{SO}_4)_3$                            | 400                      |

Dissolved in water, these coagulants undergo complex hydrolysis reactions, forming hydrolysed metal species which are the actual relevant components for coagulation.

Such reactions consume alkalinity. Due to the high positive charge of the metal ions, there is a tendency for electrons to be drawn from the water molecules in the hydration shell towards the metal ion (Gregory, 2006). This can lead to dissociation of a proton, leaving a hydroxyl group attached and a reduced positive charge for the metal. This reaction is pH dependent. High pH-values promote dissociation and vice versa. Since the metal ion is associated with many water molecules, more protons can be released. However, the decreasing positive charge makes further dissociation reactions more difficult. Table 3.2 shows the hydrolysis stages and their equilibrium constants.

Table 3.2: Reactions for hydrolysis of Al and Fe(III) and the formation of amorphous hydroxides, with their equilibrium constants (for 25°C and zero ionic strength), adapted from Gregory (2006)

|   |  | Reaction equation                                   | pK-Values        |                  |
|---|--|---|------------------|------------------|
|   |  |   | Fe <sup>3+</sup> | Al <sup>3+</sup> |
| Lye<br>dosing<br>↓<br>↑<br>Acid<br>dosing |  | $M^{3+} + H_2O \leftrightarrow M(OH)^{2+} + H^+$    | 2.2              | 4.95             |
|   |  | $M(OH)^{2+} + H_2O \leftrightarrow M(OH)_2^+ + H^+$ | 3.5              | 5.6              |
|   |  | $M(OH)_2^+ + H_2O \leftrightarrow M(OH)_3 + H^+$    | 6                | 6.7              |
|   |  | $M(OH)_3 + H_2O \leftrightarrow M(OH)_4^- + H^+$    | 10               | 5.6              |
|   |  | $M(OH)_3(s) \leftrightarrow M^{3+} + 3OH^-$         | 38*              | 31.5*            |

\* Solubility constants for amorphous precipitate

Depending on the pH value of a solution, different metal species will dominate as shown in Figure 3.3, which is drawn with help of the pK values shown in Table 3.2. It can be seen that the total amount of metal dissolved has a minimum over a certain range of pH. If the metal concentration is high enough, amorphous hydroxide will precipitate. This solubility minimum occurs around neutral pH for both metals. However, the minimum solubility of Fe(III) is much lower compared to that of Al and the minimum is considerably broader. Amorphous metal hydroxide plays a major role in sweep coagulation as explained in Chapter 3.5.

Comparing the mole fraction of each metal species in relation to the total dissolved amount, which is in equilibrium with the amorphous hydroxide, reveals significant differences between aluminium and iron species behaviour. Such evaluation is shown in Figure 3.4. For Al, the predominant species are the trivalent Al<sup>3+</sup> at low pH, up to about 4.5, and the aluminate ion, Al(OH)<sub>4</sub><sup>-</sup> at pH values higher than 7. In between, the intermediate species make only minor contributions. For iron, the various species are spread over a much broader pH range of about 8 units and each hydrolysis product is actually dominant at a certain pH value. Another difference can be found by comparing the soluble fraction of the uncharged metal hydroxides. Fe(OH)<sub>3</sub> is the dominating

dissolved iron species in the pH range 7-9, although the actual concentration is only around  $2 \cdot 10^{-8}$  M. The corresponding  $\text{Al(OH)}_3$  species is always a minor dissolved fraction. However, it is at least 10 times more soluble than  $\text{Fe(OH)}_3$  (Gregory, 2006).

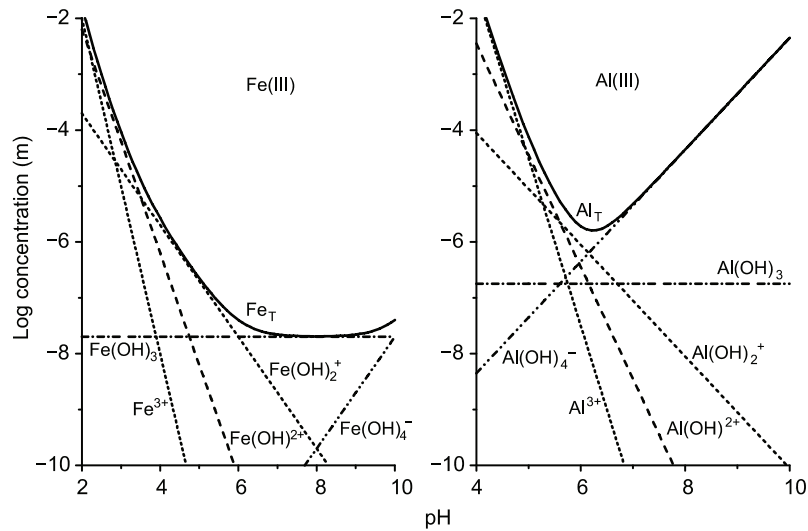

Figure 3.3: Speciation diagrams for Fe(III) and Al(III), only monomeric hydrolysis products are shown (Gregory, 2006).

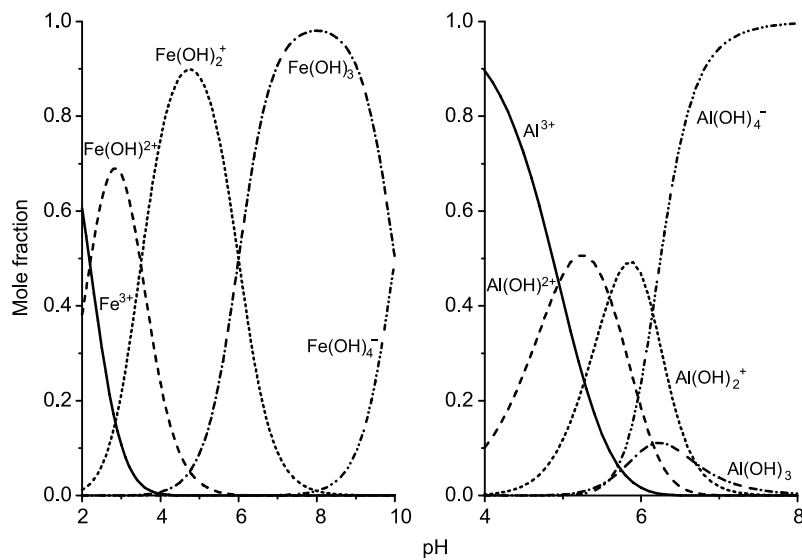

Figure 3.4: Mole fraction of hydrolyzed Fe(III) and Al(III) species relative to total soluble metal concentration (Gregory, 2006).

Thus far only monomeric hydrolysis species have been discussed. In addition, there are many possible polynuclear forms that are of importance. According to Gregory (2006), they are not likely to be significant at the low concentrations of the metals usually used in coagulation. On the other hand, polynuclear hydrolysis products can be prepared under certain controlled conditions. One example for that is  $\text{Al}_{13}\text{O}_4(\text{OH})_{24}^{7+}$  or “ $\text{Al}_{13}$ ”. Under appropriate conditions,  $\text{Al}_{13}$  forms very rapidly and essentially irreversibly. It further remains stable in aqueous solution for long periods. This circumstance is used in a variety of commercial products based on pre-hydrolysed metal salts, which are produced by controlled neutralisation of  $\text{AlCl}_3$  solutions. A common example is polyaluminium chloride (PACl). There are corresponding products containing pre-polymerised iron species, although these are not as widely used as PACl. It is further believed that  $\text{Al}_{13}$  ions are capable of polymerization, as illustrated in Figure 3.5.

According to Bratby (2006) the principal advantages of pre-polymerised inorganic coagulants are “that they are able to function efficiently over wide ranges of pH and raw water temperatures. They are less sensitive to low water temperatures; lower dosages are required to achieve water treatment goals; less chemical residuals are produced; lower chloride or sulphate residuals are produced, resulting in lower final TDS; and they produce lower metal residuals.” Since they do not have to undergo a chain of hydrolysis reactions, they are active in the water very fast. Since pre-polymerised coagulants are partially neutralised, the water pH is less affected after addition, which is important for the treatment of low-alkalinity raw waters.

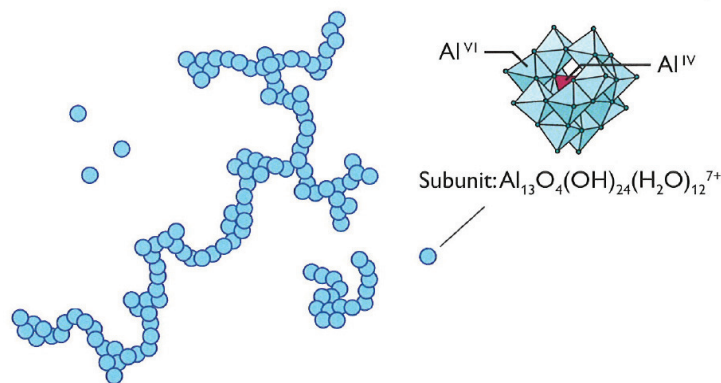

Figure 3.5: Imagined structure of  $\text{Al}_{13}$ , as monomer and polymerised, adapted from Gillberg et al. (2003).

Pre-polymerised coagulants are prepared with varying basicity ratio, which is defined as the molar ratio of negative to positive charges, and is normally given as a percentage. Different polynuclear species have a different basicity, which affects how much

alkalinity is consumed after addition to the raw water. The higher the basicity the lower is the alkalinity consumption (Gillberg et al., 2003). They also showed that turbidity removal is best with PACl having a basicity around 65%. Orthophosphate removal from waste water decreased with increasing basicity. It was concluded that the best formulation for a particular water is case specific and needs to be determined by experiments. Additionally, coagulants with higher basicity react faster and less flocculation time is needed to achieve a certain treatment goal. Several studies have shown that flocs formed with PACls are larger, stronger and settled faster than flocs formed with alum at equivalent dosages (Gregory and Dupont, 2001; Duan and Gregory, 2003; Zouboulis and Traskas, 2005).

### 3.2.2 Polymers

Polymers are long chained molecules consisting of at least one type of monomer, also called repeating unit. They refer to a large variety of natural or synthetic, water-soluble, macromolecular compounds, which have the ability to destabilize or enhance flocculation of the constituents in a given water. Most of the polymers used in water treatment are hydrophilic polyelectrolytes with molecular weights generally in the range from  $10^4$  to  $10^7$  and are soluble in water due to hydration of their functional groups. Polyelectrolytes may be classified due to their charge as anionic (negatively charged), cationic (positively charged) or ampholytic (negatively and positively charged). There are several examples of polymeric flocculents that are based on natural products, such as isinglass, starch, gelatine and alginates. However, the vast majority of polymers in common use are fully synthetic in origin. An extensive review about polymers in water treatment is presented by Bolto and Gregory (2007).

For the removal of NOM cationic polymers can be used as primary coagulants. Charge neutralisation is thought to be the predominant mechanism of coagulation with cationic polyelectrolytes, since most organic matter is present in the form of humic substances, which are essentially natural anionic polyelectrolytes in natural waters. It has been shown that the optimum dosage corresponds closely with charge neutralisation. Furthermore, a stoichiometric relationship between the anionic charge carried by the organic matter and the cationic charge of the added polyelectrolyte was demonstrated (Kvinnesland and Ødegaard, 2004). This was supported by other studies which have shown that polymers with high charge density were removing NOM more efficiently (Bolto et al., 1999; Kam and Gregory, 2001). Furthermore, the molecular weight of the polymers did only have a little or no effect, indicating that polymer bridging is not a significant mechanism. Combined use of metal-based coagulants and polymers has been shown to give synergistic removal effects. Bolto et al. (2001) obtained the same removal for colour and UV absorbers when replacing 67% of the alum dose with 0.5 mg/L or 1 mg/L PDADMAC, for water from two different sources.

The natural polymer Chitosan should be mentioned in this context. Chitosan is a cationic polymer derived from shells, especially crab shells, and is often used as a flocculent in water treatment. It can remove colour reasonably well, but is not comparable to metal coagulants with respect to DOC removal (Eikebrokk, 1999; Vogelsang, 2004). However, other studies have shown that coagulation with Chitosan followed by ultrafiltration was not sufficient and operation in compliance with the limiting values earlier presented in Table 2.2 was not possible at doses of 5 mg/L, due to poor NOM removal (Machenbach, 2003; Machenbach, 2007). The author mentioned further that “the pressure increase rates measured on the membrane also suggest unfavourable interactions between the cationic polymer and the negatively charged membrane. Removing fouling layers by CIP was more time consuming and elaborate than with metal-based coagulants.”

Since they do not consume alkalinity while added to the raw water, produce less sludge and have a low optimal dosage, polymers are well suited for the treatment of Nordic waters. However, potentially lower NOM removal, higher costs and toxicity concerns of residual monomer concentrations are arguments against an extensive usage of polymers.

### 3.3 Coagulation mechanisms

Generally, four main coagulation mechanisms can be applied for the destabilisation of water suspensions: Compression of the electric double layer, adsorption and charge neutralisation, adsorption and interparticle bridging and enmeshment in precipitate. Even though these four mechanisms are discussed separately in the following sections, they function together in practise and can be found only rarely individually. In addition, each mechanism has different demands on the coagulant dosage, some need less and some need more. It is further possible that an overdosing leads to a reduction of coagulation efficiency with two of the presented mechanisms. According to Davis (2010) the four mechanisms are:

- *Compression of the double layer.* The thickness of the double layer depends on the charge and concentration of counter ions in a solution. The higher the concentration and charge, the smaller the effective range of electrostatic repulsion (Debye-length) is. Once a certain concentration of electrolyte is reached, the energy barrier does not apply anymore (Figure 3.2 b). The particles can approach each other close enough so that the Van der Waals forces dominate and coagulation occurs.
- *Adsorption and charge neutralisation.* The adsorption of positive ions provokes a change of the surface charge. It is therefore possible that ions adsorb beyond the point of neutral or zero charge, especially when ions with a high charge density are

involved. The consequence is a charge reversal and restabilisation. Consequently, there is a concentration range where optimal destabilisation occurs. This form of coagulations is particularly achieved by highly positively charged hydroxo-complexes formed by multivalent metal ions (Al, Fe) and cationic organic polymers. The hydroxo-complexes are formed preferentially at slightly acidic pH-values, as shown in Figure 3.3. As discussed in more detail in Chapter 3.2.1, some commercial products contain already formed cationic polymers, in order to achieve faster and more efficient coagulation, i.e. pre-polymerised aluminium chloride.

- *Adsorption and inter-particle bridging.* Here the destabilisation does not occur due to compensation of charge, but by bridge formation between the particles. Commonly, long chained synthetic polymers adsorb on different particle surfaces and thus crosslink the particulate material. The efficiency of this process depends on the number of available polymer groups and the adsorption capacity of the particles. There is an optimal polymer concentration. Once it is undercut, cross-linking is not efficient due to limited polymer molecules. If it is exceeded, cross-linking is hampered by the absence of free adsorption locations.
- *Enmeshment in precipitate (sweep coagulation).* Multivalent metal ions ( $\text{Al}^{3+}$ ,  $\text{Fe}^{3+}$ ) used for coagulation form hydrolysis products once they are in solution. At low and high pH values these complexes are charged (Figure 3.3). At medium pH values however, aluminium and iron hydroxide precipitates. Precipitating hydroxide embeds other dispersed solids within the formed flocs. This type of coagulation allows the removal of all kinds of colloids, since their properties do not influence the floc formation. However, dissolved hydroxo-complexes can react with NOM contained in the water, causing the need of proportional excess dosage of coagulant in order to achieve efficient turbidity removal by sweep coagulation.

Coagulation is a fairly complex process as it depends on many different parameters such as ionic strength, coagulant dosage, pH value, but also the concentration of colloids or dissolved matter, where the removal of such is the target of the process (Bratby, 2006). However, all coagulation mechanisms discussed have in common that they need a minimum of coagulant in order to work. This coagulant concentration is defined as the concentration at where a stable suspension becomes destabilized, and is referred to as the critical coagulant concentration (CCC). However, for some coagulation mechanisms the suspension is only destabilised in a certain dosage range and restabilisation by overdosing can occur, as described above. The coagulant concentration where this happens is called the critical stabilisation concentration (CSC). If the conditions in a suspension are such that a coagulation mechanism dominates which is prone to charge reversal, such as adsorption and charge neutralisation, the suspension is only



destabilised if coagulant is dosed in the range from the CCC to the CSC. In contrast, if for example sweep coagulation is dominating, the dosing of more coagulant than the CCC has little effect on the removal of colloids and is just a waste of coagulant (Bratby, 2006). Sometimes, there is more than one optimal coagulant dose range, depending on the colloid concentration and the coagulant dosage, as shown in Figure 3.6 for three different colloid concentrations.

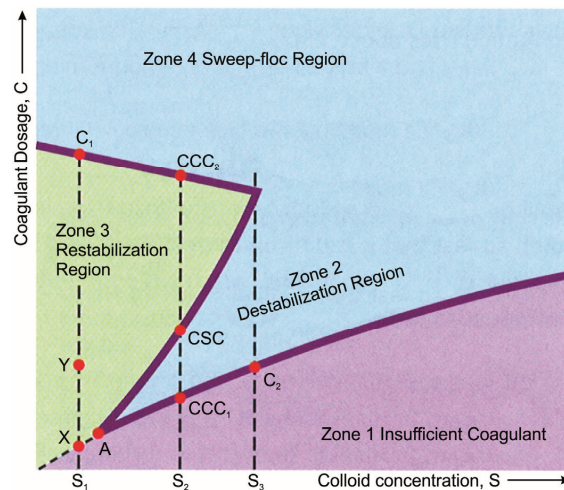

Figure 3.6: Zones of destabilisation and resetabilisation at a given pH value as related to colloid concentration  $S$  and coagulant dosage  $C$ . (Adapted from Gillberg et al. (2003), based on Stumm and O'Melia (1968)).

At the low colloid concentration  $S_1$  there is little contact opportunity for colloid - colloid interactions. Even after the amount of coagulant  $X$ , the extrapolated stoichiometric coagulant dose, is introduced to the system, no coagulation occurs due to uneven adsorption (Bratby, 2006). This also does not change after adding more coagulant  $Y$ . Now the system is in the zone where restabilisation occurs. The only possible way of removing the colloids is the dose increase until  $C_1$  is reached and metal hydroxide starts to precipitate. At increased solids concentration in point  $A$ , contact opportunity is sufficient for hydrolysis species to become adsorbed and affect destabilisation by charge effects or bridging, and precipitation takes place. At increased colloid concentration  $S_2$ , destabilisation occurs at a very narrow dosage range, between  $CCC_1$  and  $CSC$ . A dosage beyond  $CSC$  leads to restabilisation of the system until  $CCC_2$  is reached and the coagulation mechanism changes from adsorption and charge neutralisation to sweep coagulation. At high solids concentrations of  $S_3$  and higher, restabilisation does not occur anymore. At such concentrations, a double-layer repression coagulation mechanism is probably dominant. Before higher metal-hydroxo-complexes favourable

for adsorption and charge neutralisation can form, colloids are already coagulated due to the double layer compression (Bratby, 2006).

It should be noted that Figure 3.6 is only valid for an approximate pH of 4.0 to 5.0. It changes with increasing or decreasing pH. At higher pH-values between 6.0 and 9.0, no restabilisation occurs. This may be explained by a destabilisation mechanism of bridging by negative hydrolysis species with a continuous transition to precipitate enmeshment. At pH values below 2, dominant hydrolysis species are mostly hydrated metal ions and the mechanism of destabilisation is almost totally due to double layer repression.

### 3.4 NOM coagulation with metal salts

For successful NOM removal by coagulation, the composition of the organic matter has a strong influence on the treatment success. Different types of NOM have their own coagulation properties. The specific UV absorption (SUVA), which is directly related to the amount of aromatic carbon and an indicator of hydrophobicity, can be used for predicting the coagulation success as shown in Table 3.3 (Edzwald and Tobiason, 1999). The higher the SUVA of a water sample, the better the coagulation will be. Since the raw water used in this study had a relatively high SUVA (4.3 to 4.5  $\text{m}^{-1}\cdot\text{L}/\text{mg C}$ ) and NOM fractionation revealed a high content of very hydrophobic, high molecular weight humic substances (Chapter 5.3), NOM is expected to control the coagulation and DOC removal should be greater than 50%.

Table 3.3: Composition of NOM and dependence on coagulation and DOC removal (Edzwald and Tobiason, 1999)

| SUVA | Composition   | Coagulation   | DOC removal                                 |
|------|---|---|---|
| > 4  | Mostly aquatic humics, high hydrophobicity, high MW   | NOM controls, good DOC removals                     | > 50 % for alum, little greater for ferric  |
| 2-4  | Mixture of aquatic humics and other NOM, mixture of hydrophobic and hydrophilic, mixture of MWs | NOM influences, DOC removals should be fair to good | 25-50 % for alum, little greater for ferric |
| < 2  | Mostly non-humics, low hydrophobicity, low MW   | NOM has little influence, poor DOC removals         | < 25 % for alum, little greater for ferric  |

Other studies have shown similar results. Semmens and Ayers (1985) investigated coagulation of Mississippi River water and fractionated the raw and coagulated water with ultrafiltration. They reported that coagulation can remove substances with intermediate ( $1-10 \times 10^3$ ) and high molecular weights ( $10-100 \times 10^3$ ) effectively. However, low-molecular-weight substances ( $<1000$ ) cannot be removed well. Tambo et al. (1989) pointed out that humic and fulvic acids are removed by the same coagulation mechanism. However, since fulvic acids have rather small molecular weights (usually  $<1500$ ), coagulation is not as effective. Archer and Singer (2006) presented data about the treatability of NOM by coagulation, based on a large water quality survey conducted in the USA. They found a strong correlation between the SUVA or TSUVA, defined as UV254 absorption normalised with respect to TOC, and the potential NOM removal. Coagulation treatment led to decreased TSUVA values. This behaviour was explained by the preferential removal of aromatic carbon with high UV-absorbance. Raw waters with low alkalinities showed the highest TSUVA values, but also the greatest TSUVA reduction after treatment. Waters with higher alkalinity and hardness showed less reduction of TSUVA, indicating that these types are less receptive for coagulation due to their dominating content of hydrophilic organic carbon. As discussed in Chapter 5.3 in more detail, the raw water used in this study with a rather high SUVA of 4.3 to 4.5 and the characteristics of the organic matter should therefore be amenable for removal by coagulation.

The principles for coagulation of NOM can be summarized as follows: negatively charged NOM creates a coagulant demand for positively charged metal species, resulting in a stoichiometric relationship between the coagulant dosage and the raw water DOC that is pH dependent (Hall and Packham, 1965; Edzwald and Tobiason, 1999). Depending on the coagulation conditions three possible mechanisms contribute to NOM removal (Edwards and Amirtharajah, 1985; Hundt and Omelia, 1988; Bratby, 2006):

- *Charge neutralisation-precipitation.* Soluble polynuclear metal coagulant species react with humic substances. Such a reaction produces a stoichiometry between the metal added and the colour removed. Restabilisation may occur.
- *Simultaneous precipitation.* Charge neutralisation-precipitation reactions and precipitation of metal hydroxide precipitation occur simultaneously.
- *Adsorption to metal hydroxide.* Humic substances adsorb to metal hydroxide surfaces by Van der Waals interactions, hydrogen bonding, ligand exchange, anion exchange or dipole interactions.

At lower pH values from 5 to 6, colloidal NOM is removed predominantly by charge neutralisation from positively charged hydrolysis products. NOM in true solution is precipitated as aluminium or iron humate, or fulvate respectively (Randtke, 1988). At such conditions relatively low doses may exist where hydroxides do not precipitate. Coagulant dosages are proportional to the NOM concentration. At higher pH values ranging from 7 to 8, the dominating mechanisms are enmeshment in precipitate, adsorption and bridging or charge neutralisation with higher required dosages due to competition with hydroxide or less positively charged hydrolysis species. Precipitation of humate still occurs, which is either impeded by precipitating hydroxides or goes along with co-precipitation, involving adsorption of humic species onto metal hydroxide particles. At such conditions, higher dosages are necessary compared to lower pH values. The required coagulant dose increases further with increasing pH. Once metal hydroxide precipitation occurs, NOM can be either enmeshed or adsorbed to the forming flocs. However, before metal hydroxide is able to precipitate, humic and fulvic acids must first complex Al and Fe cationic species (which act as strong ligands) under most pH conditions before precipitation of  $\text{Al}(\text{OH})_3$  or  $\text{Fe}(\text{OH})_3$  occurs. The surface charge of the floc affects the ability of the coagulant to electrostatically adsorb anionic humic and fulvic acids. At pH values common in coagulation, metal hydroxides have a positive surface charge. The point of zero charge (PZC) for freshly precipitated hydroxide can be found at pH 8 for  $\text{Al}(\text{OH})_3$  and at pH 8.5 for  $\text{Fe}(\text{OH})_3$  respectively (Krasner and Amy, 1995).

Figure 3.7 illustrates some of the mechanisms relevant for NOM coagulation discussed for the case of coagulation with aluminium. Highly charged small aluminium polymers effectively neutralize their charge and form complexes with high molecular weight humic substances. The neutralized aluminium-humic-substance complexes are bridged by precipitated aluminium to form a settleable floc. Both of the required conditions, the formation of neutral aluminium-humic-substance complexes and bridging aluminium hydroxide precipitate, can be satisfied at  $\text{pH} > 5$  (Tambo and Kamei, 1978). The mobility of aluminium hydroxide increases in the range from neutral to pH 4.5, the mobility of humic substances decreases toward the acidic side, and precipitated aluminium species can make settleable flocs at  $\text{pH} > 5$ . These characteristics make pH 5.0-5.5 an optimum condition for coagulation and flocculation. It was further postulated that the relative sizes of humic substances and aluminium polymer that bring about complex formation might be very important. Because fulvic molecules are so much smaller relative to the active aluminium polymer, coagulation with alum may not be effective for fulvic substances. However, small fulvic substances can still become attached by adsorption to the active aluminium polymer (Figure 3.7).

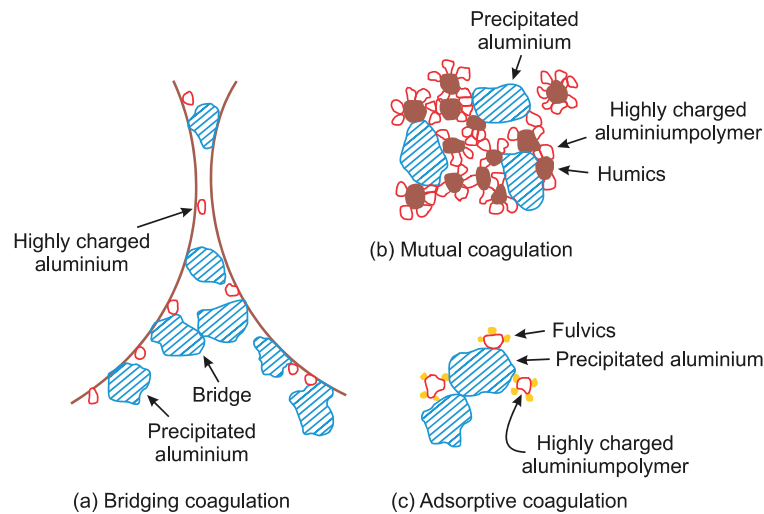

Figure 3.7: Schematic of floc formation after coagulating NOM with aluminium salts, adapted from Tambo et al. (1989)

Complexation of NOM by coagulant changes in terms of size and shape of formed complexes with increasing pH values, depending on the speciation of dissolved metal salts and the conformation of NOM molecules (Gregor et al., 1997). This complexation occurs between soluble aluminium ions and the acidic functional groups of the NOM, predominantly carboxyl groups but also some phenolic, as illustrated in Figure 3.8. At a very low pH of around 2, NOM molecules are tightly wound and present only a few anionic binding sites for metal salts. The complexation is thus limited. As the pH is raised, more anionic sites are generated by deprotonation of acidic carboxyl groups, while simultaneously, the molecules unwind and become more linear, which is the result of repulsion of the many negative charges. Each NOM molecule can now attach several times to the same metal ion but also metal bridges are established, linking organic molecules together. In this way large and often insoluble complexes are formed. Precipitation occurs most likely due to size than to charge neutrality. As the pH is raised further, aluminium hydrolysis of both complexed and unbound excess aluminium will occur. So called mixed-donor complexes are forming, containing anionic NOM and hydroxide groups, bridged by unsaturated metal. As a result, further precipitation occurs. Excess aluminium hydrolyses and forms heterogeneous flocs with the precipitated complexes. Homogeneous floc formation with entrapment will be minimal because the pH and concentration of aluminium are much lower than required for rapid precipitation sweep coagulation (Gregor et al., 1997).

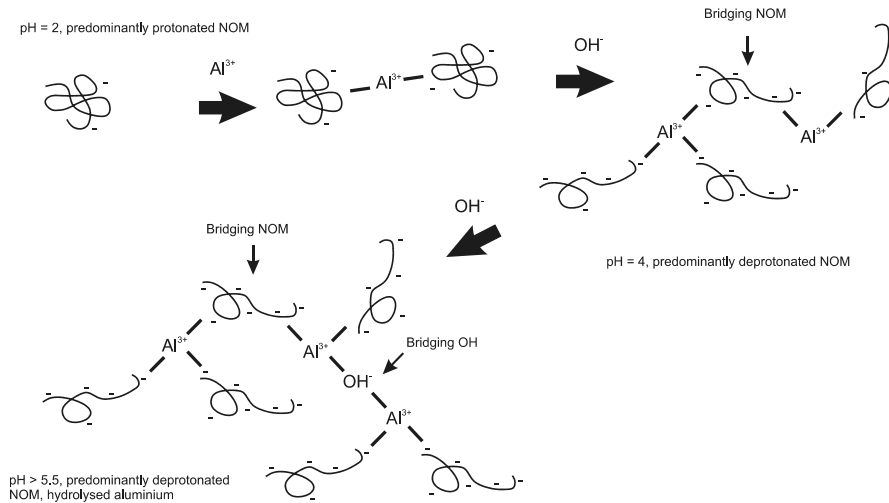

Figure 3.8: Modes of bridging between NOM and aluminium ions, adapted from Gregor et al. (1997).

The presence of multivalent ions in the raw water, i.e. calcium, can enhance NOM removal over a wide pH-range and less coagulant is required in order to achieve the same treatment result (Hundt and Omelia, 1988). This can be explained by the complexing of organic functional groups by such ions, that otherwise would need hydrolysed metal species to complete the destabilisation reactions.

As further described in Chapter 4.1, the presence of turbidity in the raw water may complicate the treatment process, and since the removal mechanisms are different for turbidity and NOM, optimal removal is achieved at different coagulation conditions. However, depending on chemical composition of the water and the structure and concentration of organic matter, it can have both stabilising and destabilising effects on turbidity particles. Particularly if multivalent ions are present (especially  $\text{Ca}^{2+}$ ), NOM molecules can be linked to the negative particle surface by bridging together with functional groups of NOM. Generally, the surface charge becomes more negative after adsorption of NOM (Beckett and Le, 1990). However, the attachment occurs in different ways. One possibility is the development of a coating layer, which can cause a steric stabilisation already at a thickness of 5-10 nm. Fulvic acids can have a similar effect as technical dispersing agents (Jekel, 1986). It was assumed that particles were not able to approach each other so close that Van der Waals forces are active, due to a thick layer of adsorbed organic substances. On the other hand, adsorbed substances can act destabilising, especially if particles are only partially covered and the adsorbed macromolecules reach out into the surrounding solution in form of loops or clews. Especially long chained macromolecules on the basis of polysaccharides can be active

in such a way and vanquish electrostatic repulsion (Schulze, 1996). Furthermore, it is possible that these macromolecules bind with their ends at different particles and can basically act as flocculent.

A reason why NOM is likely to cause problems in the coagulation processes is its inability to produce acceptable flocs, especially with treatment of low turbidity waters (Gregor et al., 1997). If present, natural turbidity provides nucleating sites for floc development. Once flocs are forming, soluble NOM can readily adsorb. For low turbidity waters, such nucleating sites can alternatively be provided by lime that is used for pH and alkalinity correction, bentonite clay, microsand or activated silica. Jarvis et al. (2005) investigated the properties of flocs created by treating NOM-rich surface water with coagulation. It was shown that the floc density decreased with increasing content of organic matter, which then strongly influenced the sedimentation and filtration properties.

Summarising, coagulation of NOM is a complex process with a lot of adjusting screws. Its efficiency strongly depends on the coagulation conditions and impacts the treatment process beyond issues of the effluent water quality. Parameters such as sludge production, treatment costs, need for chemical storage and feed facilities and overall treatment costs have to be considered. Furthermore, NOM consists of many fractions which are accessible to coagulation with varying degrees. Therefore, not only good overall DOC or colour removal need to be assured, but also the reduction of disinfection by-product formation potential or the potential for bacterial regrowth in the distribution network.

### **3.5 Coagulation at low temperatures**

As in almost all chemical or physical reactions, coagulation is influenced by temperature. For example, with decreasing water temperature the minimum solubility of aluminium hydroxide species shifts to higher pH values, as shown in Figure 3.9. For PACl, the point of minimum solubility shifts from pH 6.5 at 20°C to around pH 7.0 at 5°C. If alum is used as coagulant, the point of minimum Al solubility shifts from a pH of 6.3 to pH 6.6 to 6.8, if the temperature is decreased from 25 to 5°C (Pernitsky and Edzwald, 2006). However, the effect of temperature appears to be more pronounced when enmeshment in metal hydroxides is the dominating coagulation mechanism (Morris and Knocke, 1984). Precipitation of hydroxides is not hampered, but the flocs that are formed are smaller and thus inhibit enmeshment. Furthermore, both, iron and aluminium based coagulants are affected by temperature, though iron seems to be affected to a lesser degree.



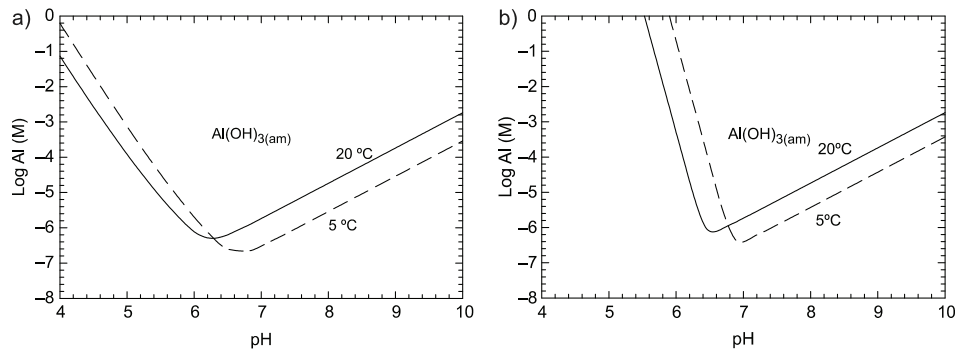

Figure 3.9: Theoretical metal solubility at different temperatures and for different coagulants: a) alum and b) PACl (Pernitsky and Edzwald, 2006)

Since hydrolysis of non-polymerised coagulants may occur in a rather uncontrolled manner, pre-polymerised coagulants seem to have a beneficial effect if coagulation takes place at lower temperatures. Jiang et al. (1996) compared three different coagulants, polyferric sulphate, ferric sulphate and alum, for the removal of humic substances from surface water at 18 and 4°C. Polyferric sulphate performed best and showed almost no influence by temperature, whereas the other two coagulants showed only poor performance at 4°C. Furthermore, residual metal concentrations were lowest with polyferric sulphate.

Lerch et al. (2004) investigated the influence of temperature on floc size and aggregate structure, applying 3 different coagulants, aluminium sulphate, PACl and ferric chloride, at 5 different temperatures in the range of 4 to 30°C. The raw water used was tap water enriched with particulate silica. The investigated coagulation was pre-treatment for ultrafiltration. It was found that increasing temperature leads to increased floc size and a more narrow size distribution. Furthermore, flocs generated with one of the aluminium based coagulants showed a clear decreasing linear relationship between their fractal dimension and the coagulation temperature. With increased temperature they became larger and had a more open structure. In contrast, flocs generated with ferric chloride showed no significant change in fractal dimension in a temperature range of 7 to 30°C. Below that, the fractal dimension decreased rapidly, indicating denser and smaller flocs.

Eikebrokk (2000) showed the influence of temperature on NOM removal by direct filtration. Two temperature ranges were investigated, a low temperature range around 1 to 2°C and a range of normal temperatures from 6 to 11°C. Aluminium sulphate was used as a coagulant at dosages of 2.5, 3.1 and 4.0 mg Al/L. The pH varied between 5.1 and 6.3. It was found that NOM was efficiently removed under all conditions and little influence of temperature was seen. In contrast, the average residual metal concentration



was strongly affected by a decrease from normal to low temperatures and increased up to 1 mg Al/L. Although average residual Al increased considerably at low temperatures, the results at optimum pH were relatively unaffected by temperature. It was concluded that low temperatures narrow the range of optimum pH. This finding is consistent with results from Morris and Knocke (1984), who found a narrow dosage optimum for treatment with aluminium sulphate at 1°C. However, they observed this behaviour only for aluminium sulphate, not for ferric chloride.

### 3.6 Flocculation

After destabilisation of a system by coagulation is achieved, flocculation begins and particles can agglomerate. Destabilisation is a rapid process and typically finishes in seconds. Thus, flocculation velocity in a destabilised suspension is characterised by the slower transport of particles to each other. This transport occurs due to diffusion or convection. According to Davis (2010) flocculation can be divided into micro-scale (*perikinetic*) and macro-scale (*orthokinetic*) flocculation.

Diffusion controlled flocculation, also called *perikinetic flocculation*, is considered as the first flocculation stage. It is based on Brownian motion and is a naturally random process. Perikinetic flocculation begins directly after destabilisation and is completed within seconds since there is a limiting floc size beyond which Brownian motion has no or only little effect. It is dominating in the range of colloidal particles with sizes below 1 µm.

The second stage of flocculation is called *orthokinetic flocculation*. It emerges from induced velocity gradients and is dominated by convective transport. It gains importance with growing particle sizes > 1 µm. Convective transport is typically slower and thus determines the overall flocculation rate in water treatment. A velocity gradient creates movement of the particles, thereby providing opportunity for contact. The degree of flocculation that can be reached in a system is governed by both, the applied velocity gradient and the time of flocculation (Figure 2.2, p. 16). These two parameters control the extent and rate of particle agglomeration, and the extent and rate of breakup of these agglomerates.

Velocity gradients are normally induced in flocculators, by routing water through baffled channels, pipes, pebble beds or other geometries in order to induce turbulence. Other forms of flocculators include basins with different build-in mixers. Camp and Stein (1943) developed the root mean squared (RMS) velocity gradient to quantify mixing in turbulent flocculation by analogy with the shear rate in a simple, one-dimensional, laminar shear flow. Their RMS velocity gradient, or G value, is given by

$$G = \sqrt{\frac{P}{\mu V}} \quad (3.1)$$

where  $P$  is the net power dissipated in the fluid,  $V$  is the fluid volume and  $\mu$  is the dynamic viscosity of the fluid. The validity of  $G$  as a design parameter is disputed as it only describes the overall intensity of fluid motion. However, the local rate of energy dissipation may vary widely with the location, and over several magnitudes. Table 3.4 shows typical velocity gradients applied in water treatment.

Table 3.4: Typically velocity gradients applied in water treatment (Bartel, 2002)

| Process step         | Required time<br>[s] | Velocity gradient<br>$G$ [ $s^{-1}$ ] | Required energy<br>[Wh/m <sup>3</sup> ] |
|----------------------|----------------------|---------------------------------------|---|
| Destabilisation      | 0.1 - 10             | 500 - 5000                            | 1                                       |
| Micro-floc formation | 30                   | 100 - 500                             | 0.3 - 2                                 |
| Macro-floc formation | 60 - 1800            | 30 - 100                              | 0.3 - 3                                 |

The dimensioning of the flocculation process has a significant influence on the properties of the formed agglomerates. With increasing shear force more but smaller and robust flocs may form. Lower shear leads to bigger but weaker and looser flocs. Enough flocculation time has to be provided in order to achieve sufficient growth etc. The requirements on the flocculation are thus defined by the subsequent treatment step, which may consist of sedimentation, dissolved air flotation and rapid or membrane filtration.

### 3.7 Filtration residues after coagulation

Every particle separation process coupled with coagulation produces sludge, though it can be minimised to some extent through process optimisation, it will still be generated. Additionally, despite that the amounts of such side product are low compared to the quantity of treated water, it is rather highly concentrated and may contain considerable amounts of metal residues from the coagulants used, cleaning chemicals etc. Therefore, it has to be dealt with in such a way that the sludge management complies with sustainable engineering practices.

Backwash water from normal backwash procedures basically contains coagulated NOM plus coagulant residues, since it is typically just carried out with permeate and pressurised air. Such sludge may be delivered to a sludge thickener, where a further concentration of the sludge may occur (Figure 3.10). The supernatant can be recycled and recirculated back to the raw water. The concentrated sludge may be discharged into the sewer network or directly transported to a WWTP, where the sludge may have some

beneficial effects on the treatment process, i.e. on  $H_2S$  fixation or phosphorus elimination. It may be further used in cement production, brick production or landscaping (Wiechmann, 2004). If the sludge is produced by chemical backwashing, it may be additionally treated by neutralisation or reduction before going to the thickening stage, depending on the chemicals used. It is further possible to introduce a second membrane treatment train before the sludge thickening stage, especially for further concentration of the permeate from the main treatment train. Such a configuration can be seen for example in Panglisch et al. (2008).

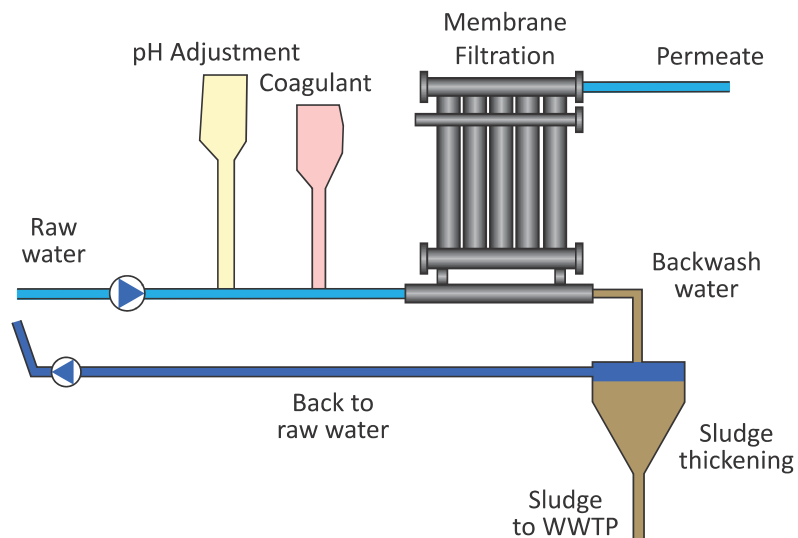

Figure 3.10: Schematic of membrane filtration with sludge thickening

It is assumed that the sludge produced with the monolith membranes used in this study can be considered as a pelletized cake, which has rather good settling and dewatering properties. However, this was not investigated in detail in this study and is a topic for future work.



# Removal of NOM from surface water

## 4.1 Rapid filtration

Rapid granular bed filtration is possibly the most used technology in potable water treatment. It is generally applied for removal of primary particles, aggregated particles by coagulation and for iron and manganese removal. Pre-treated water passes through a granular filter bed at superficial velocities between 5 and 25 m/h. The flow direction is typically downward. Both, gravity and pressure driven systems are common. During the process, which is also called depth filtration, particulates are transported into the granular media comprising the filter bed and attach to its surface and thereby retained and removed from the fluid flow. Solids are accumulating over time within the voids and on top the surface of the filter. As a consequence the head loss increases with time and the effluent particle concentration may begin to rise as particles make their way through the filter bed. After a certain threshold value of head loss, a particle breakthrough level or a maximum filtration time is reached, the filter is backwashed to remove accumulated particulates. Typical filter cycles range from 12 to 96 hours. Sand, crushed anthracite coal, GAC, pumice, garnet or ilmenite are common filter media materials. (Cleasby and Logsdon, 1999).

In order to achieve efficient NOM removal, coagulation with iron or aluminium based as well as organic coagulants is necessary before rapid filtration takes place. Depending on the water quality, different pre-treatments can be found in practise, as shown in Figure 4.1. If floc or particle load must be reduced prior to filtration due to, for example, high turbidity in the raw water, conventional pre-treatment, including rapid mixing, flocculation and settling, is applied (Figure 4.1 c). In these cases flotation and

microsand ballasted lamella sedimentation are favoured (Ødegaard et al., 2010). Since raw waters in Norway are typically very low in turbidity, more compact treatment schemes dominate as shown in the treatment trains in Figure 4.1 a) and b).

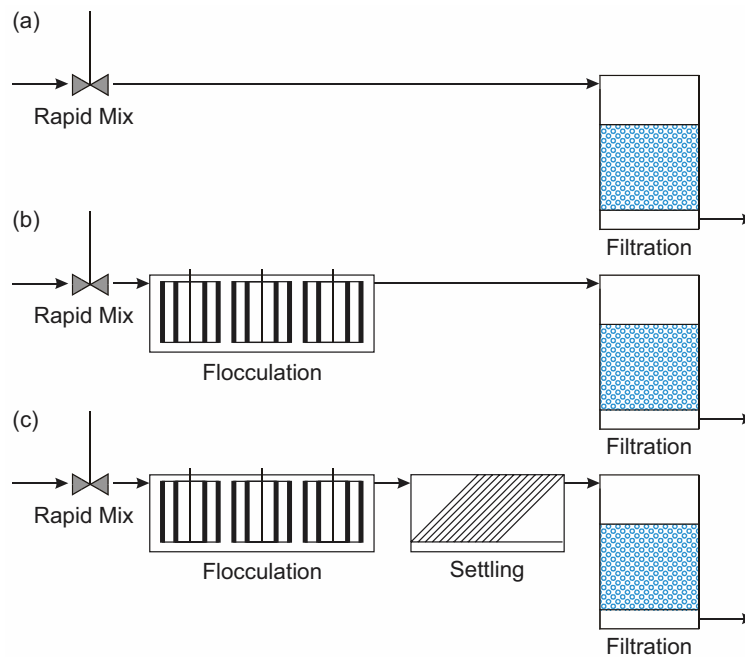

Figure 4.1: Three filtration modes. (a) Inline filtration. (b) Direct filtration. (c) Conventional filtration (Hendricks, 2006)

Pre-treatment of surface waters by chemical coagulation (see Chapter 3) is essential to achieve efficient removal of small particulates in rapid filters. Commonly used coagulants are aluminium sulphate (ALG), prepolymerised aluminium chloride (PACl), ferric chloride (FeCl) or iron chloride sulphate (JKL). Cationic polymers and organic polymers like chitosan (Chi) have been applied as well.

In this work NOM removal was a primary objective. Turbidity removal was only a side aspect. It should be noted however, that the turbidity of the treated water is still important, i.e. with respect to following treatment steps such as disinfection or pathogen removal. Here, an optimization conflict may exist, since optimal conditions for NOM removal and turbidity may differ as shown in Eikebrokk (1999), where the effluent water quality (turbidity, organic carbon content and residual metal concentration) after coagulation of high coloured water with JKL and PACl and subsequent filtration was presented, in dependence on coagulation pH and coagulant dosages. At higher pH values the effluent turbidity was increasing, the DOC removal decreased however and

the residual metal concentration increased. Furthermore, the optimum pH window widened at higher coagulant dosages (as further described in the next Chapter 4.1.1), giving an operator more flexibility for achieving good NOM and turbidity removal and low residual metal concentrations at the same time. Furthermore, results pointed further out that this is especially relevant when the coagulation takes place in the upper part of the optimum pH range for residual Fe and NOM removal (Eikebrokk, 1999).

The two following chapters discuss variations of rapid filtration, especially suited for low turbidity and alkalinity raw waters with a high content of NOM.

#### 4.1.1 Contact filtration

Contact filtration, also known as inline filtration or sometimes called direct filtration as well, forgoes extensive flocculation and sedimentation steps. The coagulant is added just prior to the filtration, using a weir, a static mixer or some other kind of installation for ensuring the necessary degree of mixing. After that, no mechanical or hydraulic flocculation is applied and the time for flocculation reactions to take place before the water reaches the filter is rather short. However, flocculation takes place in the hydraulic head of the filter and in the filter pores. The flow of water through a porous media filter introduces shear forces and thus benefits flocculation. Particles deposited in the filter bed can continue to react with material still in the liquid phase or with themselves. Figure 4.2 shows a schematic of a typical contact filtration plant as it can be found in Norway, including coagulation pH adjustment and corrosion control using lime and carbon dioxide, and chlorination or UV radiation for disinfection.

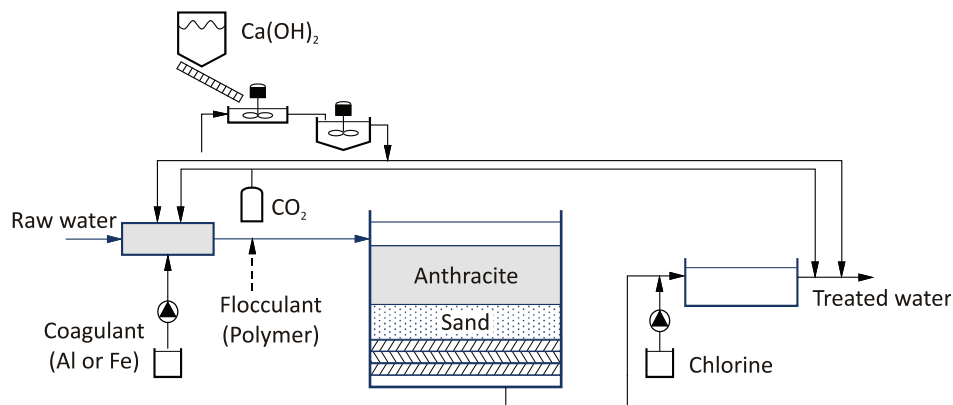

Figure 4.2: Typical flow scheme for a contact filtration plant for NOM removal in Norway including pH adjustment, corrosion control and disinfection, adapted from Ødegaard et al. (1999)

The two key parameters for optimal coagulation and flocculation, and a good filtration performance as a consequence of that, are coagulant dosage and pH-value. These two parameters directly control DOC and colour removal and the residual metal concentration (Eikebrokk, 1996, 2000). In these studies Eikebrokk investigated the contact filtration performance of a dual media anthracite-sand filter in dependence on different colour content in the raw water (15, 30 and 50 mg Pt/L which corresponds to a TOC range of 2 to 6 mg C/L), different coagulants (ALG, PACl, JKL, Chi and others) and dosages. He found that colour and DOC can be efficiently removed at low coagulant dosages. However, these dosages are too low for maintaining a low residual metal concentration. Therefore, higher coagulant dosages had to be applied to meet all drinking water standard requirements. These doses were called absolute minimum dosages. However, operation at these dosages might be difficult in practise since the optimum “pH-window” is rather narrow and operation outside these limits would inevitably lead to higher residual metal concentrations than demanded by legal regulations. Therefore, Eikebrokk introduced a “practical minimum” dosage, which is 25% higher than the absolute minimum dosage. When using these dosages, the pH window for optimum process performance and compliance with the water quality standards can be obtained within a wider pH range. The practical minimum dosages and the corresponding pH windows are summarized in Table 4.1 for four coagulants. In general, NOM removal rates of 75 to 90% for colour and 40 to 70% for DOC were reported, depending on the coagulation conditions and the coagulant type. The poly-aluminium and ferric chlorides were also found to possibly have some benefit over alum in terms of dose requirements and range of optimum pH values (Eikebrokk, 1996, 2000).

Table 4.1: Minimum practical coagulant dose recommendations when using ALG, JKL or Chi in contact filtration of raw waters with colour levels of 15, 30 and 50 mg Pt/L (Eikebrokk et al., 2006).

| Raw water colour | Raw water SUVA<br>$L \cdot (m \cdot mg C)^{-1}$ | Minimum specific coagulant dosage and optimum pH range<br>mmol Me or mmol Chi/g TOC; ( $\mu g$ Me or $\mu g$ Chi/mg Pt) |                     |                     |                     |
|------------------|---|---|---------------------|---------------------|---------------------|
|                  |   | ALG<br>pH 5.8 – 6.6   | JKL<br>pH 4.0 - 5.5 | PAX<br>pH 5.7 - 6.7 | CHI<br>pH 5.0 - 6.0 |
| RW15             | 3.8   | 16 (78)   | 16 (162)            | 14 (67)             | 0.6 (110)           |
| RW30             | 4.3   | 20 (63)   | 20 (128)            | 17 (54)             | 0.7 (80)            |
| RW50             | 4.8   | 26 (61)   | 26 (100)            | 20 (49)             | 0.8 (70)            |

ALG-aluminium sulphate, JKL-ferric chloride; PAX-poly aluminium chloride; Chi-Chitosan.

For Me-coagulants: Dose levels needed to obtain < 0.1 mg residual Me/L, > 90% and 50-60% colour and TOC reduction, respectively. Absolute minimum doses are 25% lower than the given practical minimum doses.

For Chitosan: Dose levels needed to obtain > 60 % and 20-35% colour and TOC reduction, respectively.



Optimal coagulant dosage is very important for good process performance, especially while using contact or direct filtration. The coagulant dosage directly corresponds to the solids load to a filter since they are not removed by sedimentation or other separation options. Too high dosages therefore lead to high head loss rates and low unit filter run volumes without removing proportionally more pollutants (Pernitsky and Edzwald, 2006). Early filter breakthrough is another consequence. Too low dosages on the other hand may lead to insufficient removal or high residual metal concentrations, as described above. Pernitsky and Edzwald also stated that the type of coagulant influences the head loss increase. High basicity PACls resulted in lower head loss rates than alum or low- and medium basicity PACls. PACls with sulphate showed increased head loss rates compared to non-sulphated PACls. Further, raw water quality criteria was given as an approach for estimating if a raw water is suited for contact filtration or not. Generally it was stated that, turbidity should be below 10 NTU and the algae biomass content below 10 µg/L as chlorophyll-a, and the waters should be treatable with alum doses at or below 10–15 mg/L. Furthermore, filtration may not be feasible when the raw water TOC exceeds 3 mg/L and UV absorbance exceed 0.07 cm<sup>-1</sup> for supplies characterized by a SUVA of about 3 or greater (Pernitsky and Edzwald, 2006).

As previously mentioned in Chapter 3, one of the greatest practical problems faced in removing soluble NOM from low turbidity waters is the inability to produce an acceptable floc due to lack of readily available nucleation sites provided by natural turbidity (Gregor et al., 1997). Gregor et al. further suggested that these essential floc nucleating sites can be provided by the lime that is used for pH and alkalinity correction, provided that the lime is added in sufficient quantity and at a point where it retains some of its particulate nature. Rebhun et al. (1984) found that early breakthroughs shortened the filtration cycles while using contact coagulation-filtration of humic substances in their experiments. The filtration runs could be prolonged, however, by combining alum and a high molecular weight cationic polymer. There was an optimum polymer dose range, where lower and higher doses than optimum gave shorter filtration runs. Polymer dosage increased floc strength, increased attachment and/or decreased particle detachment within the filter bed and thereby prolonged the filter run times. Bolto and Gregory (2007) stated that cationic polyelectrolytes have a distinct advantage over the metal salts that are commonly used in direct filtration, because they effect charge neutralisation without the formation of additional solids in the form of a metal hydroxide precipitate. The flocs from inorganic coagulants take up much of the space in the filter media, rapidly causing a pressure drop.

Table 4.2 summarizes the advantages and disadvantages of contact filtration.

Table 4.2: Advantages and disadvantages of contact filtration

- |  |   |
|--|---|
| <ul style="list-style-type: none"> <li>⊕ Good treated water quality if operated under optimized conditions</li> <li>⊕ Reduced footprint and simpler process scheme compared to conventional filtration</li> <li>⊕ Higher filter velocities and more shallow filters compared to Molde process</li> </ul> | <ul style="list-style-type: none"> <li>⊖ High operator competence necessary</li> <li>⊖ Sensitive to changes in the raw water</li> <li>⊖ Possibly not feasible at very high DOC in the raw water</li> <li>⊖ Inconsistent filtrate quality after ripening and before breakthrough</li> <li>⊖ Barrier effect depends on operation</li> </ul> |
|--|---|

#### 4.1.2 The Molde process

The so called “Molde process” is a special form of rapid media filtration where in addition to anthracite and sand, a third alkaline filtration layer with marble is introduced. An example of a process scheme is shown in Figure 4.3. Full scale introduction of the process started at the beginning of the 1990s. In a period from 1993 to 2011 around 31 plants have been built or are under construction. Two thirds of them are smaller plants with a treatment capacity up to 20,000 m<sup>3</sup>/d. 10 plants have a capacity between 20,000 and 60,000 m<sup>3</sup>/d. The biggest plant was built in 1997 in Bergen, the third largest city in Norway, having a capacity of 80,000 m<sup>3</sup>/d. The first pilot studies investigating this treatment concept were done in 1991 in a city called Molde, thus making the process to be known as the “Molde process”.

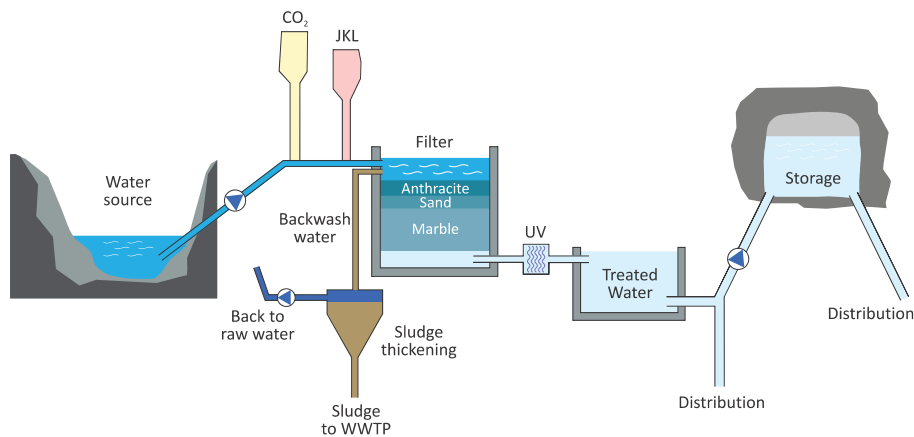

Figure 4.3: Treatment scheme of the Molde process, adapted from Hammersland (2009)

Before the filtration step CO<sub>2</sub> is added to the raw water. The amount of CO<sub>2</sub> dosed is used to regulate the alkalinity and hardness of the treated water. The more CO<sub>2</sub> is dosed,

the more marble is dissolved in the actual filtration step. Since the coagulation pH is normally below 4.5, dosing the CO<sub>2</sub> at the inlet stage does not influence the coagulation step. The coagulant is dosed after the CO<sub>2</sub>. Almost exclusively iron based coagulants, i.e. iron chloride sulphate (JKL), are used in the Molde process because their very low optimal coagulation pH for DOC and colour removal. Since the coagulant is an acid by itself, normally no extra pH adjustment is necessary. Only dosing the coagulant adjusts the pH sufficiently if the raw water does not have a too high alkalinity, which is often the case in Norway. The mixing of chemicals takes place in static mixers and no special flocculation is applied. However, a sufficient degree of flocculation is ensured due to time necessary for transportation of the water to the filter unit and residence in the filter head before the filtration. In the filter, particles and flocculated NOM are retained in the anthracite and sand filter layers. The water pH does not change significantly in this stage of the process. In the third alkaline filtration layer marble is dissolved, resulting in an increase of pH, alkalinity and hardness. Furthermore, the residual dissolved iron precipitates there as iron hydroxide due to the increase in pH. After filtration the treated water is disinfected and fed into the distribution net.

The rapid filters in treatment plants using the “Molde process” are dimensioned in a similar way compared to conventional rapid filtration. At the largest WTP in Bergen, Svartediket, for example, filters are dimensioned for a maximum filter velocity of 8 m/h. However, the average filter velocity is 4.4 m/h. The filter cycle length is between 12 and 36 hours. The backwash velocity is set at 60 m/h, which is higher compared to conventional rapid filtration (typically 30 to 35 m/h) due to the higher density of the marble. The iron dosage is normally between 2.5 and 6 mg Fe/l, depending on the raw water quality. The coagulation pH is in the range of 3.9 to 4.3. Marble is replaced once or twice a week, before a backwash takes place. The necessary empty bed contact time (EBCT) for sufficient reaction with the marble is estimated to be 15 minutes. If the thickness of the marble layer approaches 1.5 m, turbidity and residual iron concentration rise perceptibly in the treated water. The treated water has typically a turbidity of 0.05 NTU and a colour of 2 mg Pt/L. The costs for treatment chemicals, like coagulant, CO<sub>2</sub> and CaCO<sub>3</sub>, are normally in the range of 0.10 NOK (1.25 Euro cent) per m<sup>3</sup> treated water. The chemical costs are twice as high if additional pH adjustment i.e. by hydrochloric acid is required (Hammersland, 2009; Brandt, 2010).

The Molde process is a simple and compact process since it integrates colour removal, hardening of the water and an eventual corrosion control all in the same filter. Since Norwegian raw water typically has a low pH and alkalinity, no extra pH adjustment is normally necessary. Coagulation takes place at low pH values, which drastically improves DOC and colour removal, and avoids high residual metal concentrations at the same time. Table 4.3 shows an overview of advantages and disadvantages of the Molde process.

Table 4.3: Advantages and disadvantages of the Molde process

|   |  |   |  |
|---|--|---|--|
| + | Simple and compact process                                     | - | Filters are build higher than normal                             |
| + | Efficient NOM removal due to low coagulation pH...             | - | High backwash velocity compared to conventional rapid filtration |
| + | ... but low residual metal concentrations due to marble filter | - | Loss of 10 to 15% of marble due to washing out of fine fraction  |
| + | Low chemical costs   | - | Limited flexibility for optimizing backwash of marble filter     |
| + | No extra corrosion control necessary                           |   |  |

Recently, a couple of modified variations of the Molde process have been introduced to the market. In the Larvik process, two separated filters are used, first, a classical dual media filter and second, a marble filter. The coagulant is dosed before the first filtration step and CO<sub>2</sub> before the second. This configuration has the advantage that both filters can be optimized independently, i.e. with regards to backwashing conditions and cycle length. Due to that the chemical demand and the loss of marble can be reduced. However, for this configuration higher investment costs are necessary.

## 4.2 Oxidation and biofiltration

Oxidation biofiltration is an established technology in potable water treatment. However, this process has not been fully implemented in Norway for the treatment of surface waters with low turbidity, alkalinity and hardness, but with high concentrations of NOM and colour. The ambition of this process combination is the conversion by advanced oxidation of poor biodegradable organic carbon which is normally dominant in the raw water into forms which can be degraded easily and removed in the biological filtration. Furthermore, organic micro-pollutants may be also oxidised and efficiently removed. Oxidation is additionally a disinfection process. Pathogens and parasites may be thus inactivated or destroyed prior to the biological filtration. Ozone is often used as the oxidant. However, other possibilities have been also investigated, such as advanced oxidation methods combining ozonation with UV-radiation and / or hydrogen peroxide (H<sub>2</sub>O<sub>2</sub>), photocatalytic oxidation (e.g. UV radiation and TiO<sub>2</sub>) or other enhancing chemicals like KMnO<sub>4</sub>. In the biological filtration step different media can be used for the biofilm support, such as powdered activated carbon (PAC), granulated activated carbon (GAC), volcanic rock, expanded clay aggregates, sand, special carriers for biofilm and many others.

Melin et al. (2002) investigated ozonation/biofiltration for the treatment of Nordic waters at cold temperatures, with focus on colour and DOC removal as well as the influence of nutrient availability and temperature on the treatment efficiency. Figure 4.4 shows the schematic of their full scale treatment plant, which was in operation for 1 ½

years. They achieved an average 23% of TOC removal starting from 3.72 mg C/L. This corresponds to an absolute TOC removal of around 1 mg C/L. Colour removal was more efficient at around 80%, starting from a raw water colour of 27 mg Pt/L. The results showed that significant biological activity can be achieved and maintained in a biofilter treating ozonated water even at low temperatures and phosphorus limited conditions. The TOC removal depended linearly on the temperature. At 1-2°C average TOC removal was around 20% compared to 29% at around 30°C. On average about half the BDOC was removed.

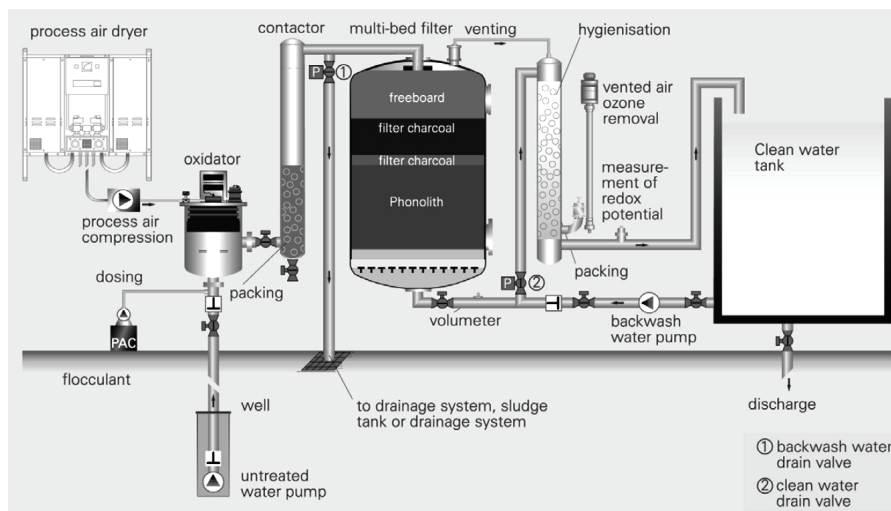

Figure 4.4: Schematic of an ozonation/biofiltration plant (Melin et al., 2002)

Oxidation/biofiltration has also been investigated as a pre-treatment option for low pressure membrane filtration. Aside from the previously mentioned advantages, this process combination contains an additional barrier against pathogens and particles. Biological fouling of the membrane is expected to be low due to the biologically stable effluent from the biofiltration step. Azrague et al. (2009) investigated the treatment of Nordic water with a treatment scheme as shown in Figure 4.5, combining ozonation, biofiltration and membrane filtration (OBM). Specific ozone dosage was 0.18 mg O<sub>3</sub> per mg Pt. Empty bed contact times of 35 minutes in the ozonation column and 30 minutes in the biological filter were realised. The membrane unit was based on a hollow fibre GE/Zenon ZW-10 module, made of PVDF and with a nominal pore size of 40 nm. The operational flux was at 60, 70 and 80 L/(m<sup>2</sup> h).

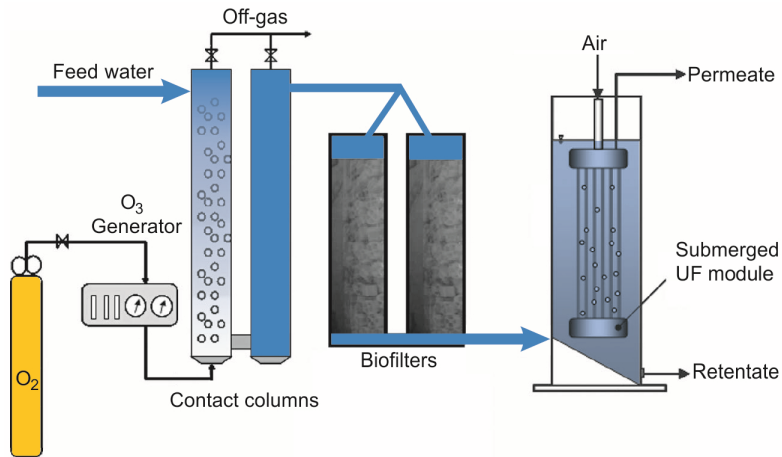

Figure 4.5: Schematic sketch of the OBM process, adapted from Azrague et al. (2009)

Ozonation was able to remove around 80% of the colour and around 60% of the  $UV_{254}$  due to loss of aromaticity and depolymerisation. However, DOC reduction was rather small with around 10%. The biologically degradable organic carbon (BDOC) increased after oxidation, but was efficiently removed by the following biological filtration. In conclusion, the OBM-process was recommended only for the treatment of waters with low levels of NOM.

Hallé et al. (2009) evaluated river water treatment by roughing filtration and rapid biological filtration without oxidation or chemical addition as a pre-treatment for subsequent ultrafiltration. Biofiltration was applied in order to reduce membrane fouling by removal of biopolymers such as proteins and polysaccharides prior to membrane filtration. The river water turbidity ranged from 0.45 to 62 NTU, the DOC from 5 to 7 mg/L. The dominant organic fractions were humic substances, according to LC-OCD analysis. Two biologically active filters were compared. The first filter used anthracite on top of sand (50:50) as media and had an EBCT of 5 minutes. The second was filled with the same materials but with a different ratio (20:80) and used a longer contact time of 14 minutes. As membrane a bench scale GE/Zenon ZW-1 ultrafiltration module was used (PVDF, MWCO 400 KDa, corresponding to a pore size of  $\approx 20$  nm). The module was operated in dead end mode with a constant flux of  $57.5 \text{ L}/(\text{m}^2 \text{ h})$  at  $20 \text{ }^\circ\text{C}$ . The investigated setup showed the substantial removal of biopolymers during biofiltration, whereas removal of humic substances and low molecular weight acids were much lower on a percentage basis. The total average DOC removal was found to be 11%. However, more DOC was removed in the warmer periods of the year. Hallé et al. (2009) stated that the removal of biopolymers “was influenced by contact time and temperature. The biofilter with the longer contact time led to greater reductions in both hydraulically reversible and irreversible fouling. The extent of hydraulically reversible fouling was

related to the membrane influent biopolymer concentration.” In contrast, the level of hydraulically irreversible fouling was not related to that. This behaviour may indicate an influence of the actual composition of the biopolymer fraction.

Summarizing, Table 4.4 Table 2.1 shows some advantages and disadvantages of oxidation and biological filtration, if applied to the treatment of Nordic waters.

Table 4.4: Advantages and disadvantages of oxidation and biological filtration

- |   |  |
|---|--|
| <ul style="list-style-type: none"> <li>⊕ Biofiltration reduces biological membrane fouling and re-growth potential in distribution network</li> <li>⊕ Oxidation may be designed to destroy organic micro-pollutants or primarily for NOM conversion</li> <li>⊕ Treatment train contains multiple hygienic barriers</li> </ul> | <ul style="list-style-type: none"> <li>⊖ Poor DOC removal; limited by amount converted to biodegradable DOC or the degree of oxidation</li> <li>⊖ Does not appear to be well suited for waters with high NOM content</li> <li>⊖ Potential for oxidation by-product formation</li> <li>⊖ High costs and high energy demands may be a challenge</li> </ul> |
|---|--|

### 4.3 Ion exchange

Another alternative for the removal of NOM is ion exchange. Due to the negative charge of NOM even at normal pH values, it can react with anion exchangers. If the raw water has a high turbidity ( $> 0.5$  to  $1.0$  FTU), pre-treatment by rapid sand filtration may be necessary, otherwise micro-sieving may be sufficient. Then, the actual ion exchangers are placed, normally two in series. However, ion exchange is typically only used in small treatment plants in Norway (Ødegaard et al., 2010). Figure 4.6 shows a characteristic flow diagram of a WTP with focus on NOM removal.

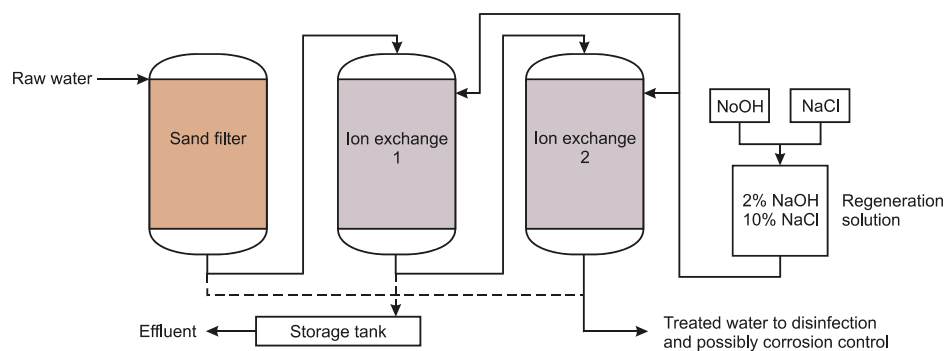

Figure 4.6: Typical flow diagram for an ion exchange treatment plant for the removal of humic substances, adapted from Ødegaard et al. (1999).

In the ion exchangers strongly alkaline resins are used, with a tertiary methyl amine group as functional group and a grain size ranging from 0.3 to 1.5 mm. The exchange capacity of the resins cannot be foreseen and has to be determined experimentally. Table 4.5 shows a selection of typical exchange resins used in Norway together with their isotherm characteristics. Magnetic ion exchange resins (MIEX), which have become very popular in some parts of the world, have not been used in Norway so far. In practise, relatively fast leakage of humic substances through the exchange columns may occur. As a consequence, the regeneration frequencies are rather high and the utilisation of the resin capacity is relatively poor. After breakthrough the ion exchangers are backwashed and regenerated, normally with an alkaline salt solution. The regeneration solution is typically reused 7–8 times and in such a manner that about 1/8 of the regeneration solution volume is substituted after each regeneration (Ødegaard et al., 1999; Ødegaard et al., 2010).

Table 4.5: Typical capacity parameter values for commonly used macroporous ion exchange resins (Ødegaard et al., 1989)

| Resin            | Matrix                 | Specific surface<br>[m <sup>2</sup> /g] | Grain size<br>[mm] | Theoretical capacity<br>[mequiv/ml] | K <sub>F</sub> <sup>*</sup> | N <sup>*</sup> | Manufacturer |
|------------------|------------------------|---|--------------------|-------------------------------------|-----------------------------|----------------|--------------|
| Lewatit MP 500 A | Styrenedivenyl Benzene | 45-50                                   | -                  | 1.0                                 | 15.6                        | 1.15           | Bayer        |
| Dowex MSA-1      | Polystyrene            | 23                                      | -                  | 1.0                                 | 4.4                         | 1.02           | Dow          |
| Duolite A 171    | Styrenedivenyl Benzene | -                                       | 0.8-1.1            | 0.8-1.1                             | -                           | -              | Duolite      |

\* Based on Freundlich isotherm model:  $x/M = K_F \cdot C^n$ . Contact time: 1 day, pH = 7, C<sub>0</sub> = 15-16 m<sup>-1</sup> (UV-ext.)

In practise, contact time is a more relevant parameter than the filter velocity. In WTPs with focus on colour removal, a contact time of at least 10 min at maximum flow is used, in order to achieve effluent colour below 10 mg Pt/L. If the colour needs to be reduced further, longer contact times are necessary. Typically a bed depth of 0.5-2m is used and the recommended filter rate at design load should not exceed 20m/h. Table 4.6 summarizes some advantages and disadvantages of the ion exchange process.

Table 4.6: Advantages and disadvantages of ion exchange

- |   |   |   |   |
|---|---|---|---|
| + | Good removal of charged NOM                                 | - | Poor removal of neutral and small sized fraction                      |
| + | Results in a high quality product                           | - | Good pre-treatment required (i.e. no particulate matter in feedwater) |
| + | Potential for tailoring exchange media for local conditions | - | Complete capacity of media not used (i.e. due to early breakthrough)  |
|   |   | - | Management of waste streams from regeneration / backwash procedures   |



#### 4.4 Adsorption / Activated carbon

Activated carbon is the sorbent material most widely applied in drinking water treatment. It is manufactured from natural carbon containing products like coal, peat or wood by pyrolytic carbonization and thermal activation. Preparation of activated carbon creates both macroporous and microporous structures. The final pore size distribution depends on the raw material as well as on the manufacturing process. The surface charge of activated carbon can vary within a wide range, with IEPs from 2.2 to 10.6. However, for 75% of instigated commercial products an IEP larger than 7.5 was found. NOM adsorption is affected by several physical and chemical parameters. A positively charged carbon surface is favourable for the binding of the negatively charged NOM. However, the ultimate adsorption capacity is determined more by the combined effects of pore structure and size of the NOM compounds. Thus, activated carbon is an efficient sorbent media for NOM. The non-removable fraction of NOM is usually < 10% (Fettig, 1999). Although activated carbon adsorbs NOM very well, the process is not recommended for the treatment of surface water containing high concentrations of DOC and colour. The adsorption capacity may quickly be reduced by pore blockage caused by large NOM molecules (Kaastrup and Halmo, 1989). The effects of treatment with activated carbon were investigated for three different humus sources in that study, Norwegian brook water, Norwegian bog water and commercial humic acid. Nevertheless, activated carbon may be used as a final polishing step in combination with other treatment processes.

An alternative to activated carbon may be the adsorption of NOM to activated metal-oxide surfaces, either iron or aluminium based. Commercial granular or powdered alumina products are most often gamma aluminas ( $\gamma\text{-Al}_2\text{O}_3$ ) with pore volumes of 300-800  $\text{mm}^3/\text{g}$  and BET<sup>2</sup> surface areas of 100-300  $\text{m}^2/\text{g}$ . Their pore radii are mainly found within the mesopore size range. In aqueous solution, the surface is generally covered with hydroxyl groups (Fettig, 1999). Weak organic acids can be bound according to a ligand exchange mechanism. NOM removal by  $\gamma\text{-Al}_2\text{O}_3$  is largely dependent on pH, where maximum solid-phase concentrations are obtained at pH-values between 5 and 6.5. Activated alumina can adsorb a significant portion of NOM, however, non-adsorbable fractions up to 60% have been found. Compared to activated carbon, the ultimate capacity is much lower due to the smaller surface areas. Moreover, the material is not superior with respect to adsorption kinetics.

---

<sup>2</sup> The first initials of the family names of Stephen Brunauer, Paul Hugh Emmett, and Edward Teller, who published 1938 an article about the BET theory, which explains physical adsorption of gas molecules on a solid surface and serves as the basis for an important analysis technique for the measurement of the specific surface area of a material.

Teermann and Jekel (1999) investigated highly active granulated iron hydroxide with  $\beta$ -FeOOH modification for the removal of three fulvic acids with different molecular weight distribution.  $\beta$ -FeOOH showed high adsorption capacities for both smaller and higher molecular weight fulvic acids where larger molecules were preferably adsorbed. Adsorption capacities of 30 to 60 mg DOC per gram sorbent were reached, in equilibrium with a DOC of 5 mg/L at a pH of 6. The non-adsorbable fraction was found to be rather low, less than 5.5 % of the fulvic acids. The authors stated that the “addition of calcium increased the adsorption capacity significantly: the higher adsorption pH the more calcium was involved in DOC removal. Although adsorption capacity decreased somewhat with increasing pH, this pH dependency was low.” It was further concluded that active  $\beta$ -FeOOH is a promising adsorbent as far as adsorption capacity is concerned and that pH adjustment prior to an adsorption filter may not be necessary. Complete regeneration was possible by rinsing in two steps with calcium free sodium hydroxide solutions. In addition, more research may be required in order to evaluate the practical potentials of  $\beta$ -FeOOH granules including regeneration and re-adsorption. Table 4.7 summarizes advantages and disadvantages of adsorption.

Table 4.7: Advantages and disadvantages of adsorption

- |  |   |
|--|---|
| ⊕ Depending on the adsorbent very good NOM removal   | ⊖ Depending on adsorbent, regeneration is costly and time consuming                 |
| ⊕ Good process design flexibility (i.e. dedicated filters or in combination with other filter media) | ⊖ Rather short operating intervals if high NOM concentrations in raw water          |
| ⊕ Can potentially remove organic micro-pollutants  | ⊖ Adsorbent has maximum capacity that may be difficult to utilize fully             |
| ⊕ Can be combined with oxidation or biofilm growth on adsorption media                               | ⊖ Potential clogging / obstruction of adsorption sites by large molecular fractions |

## 4.5 Membrane filtration

Membrane filtration has become a standard technique in water treatment and is broadly applied. The installed treatment capacity of WTPs using membranes has been grown exponentially during the last two decades, as shown in Figure 4.7, which cumulates plant capacity data from the major membrane manufacturers. One reason for that may be found in more stringent legislative pressure on water treatment, demanding reliable removal of water borne pathogens (i.e. protozoa) and the use of state of the art technologies, like membranes. Another reason may be the increasing water shortage in many areas of the world, boosting for example the use of sea water as a water source applying membrane desalination as the treatment technology, where membranes are also often used as pre- and main-treatment steps. Additionally, the quality of membrane

and module designs has advanced dramatically, providing much more compact, robust and reliable treatment solutions.

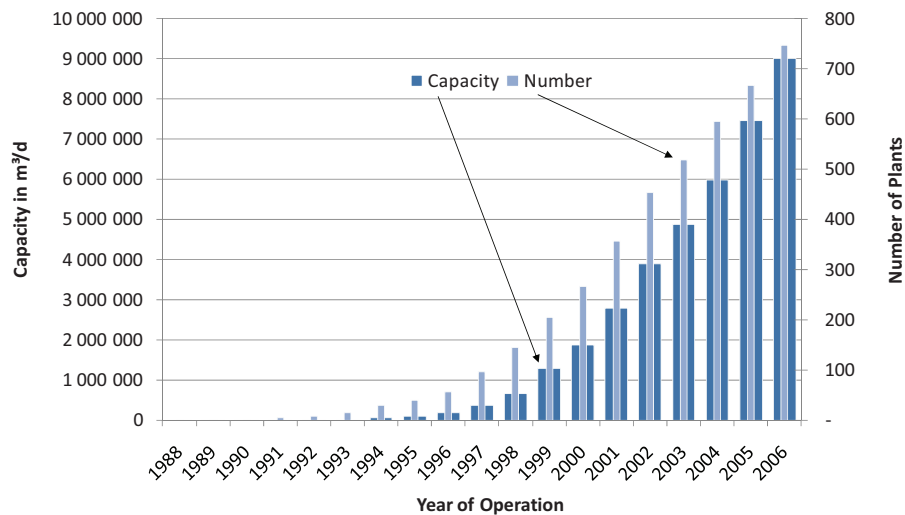

Figure 4.7: Cumulated installed treatment capacity and number of plants using membranes, from 1988 until 2006 (only plants with a total capacity of  $>8\text{m}^3/\text{d}$ , based on cumulated data from major membrane manufacturers)

#### 4.5.1 General

Membranes are semi-permeable structures, which are at least permeable for some components, but not for others. Water is forced against the membrane surface, resulting in the production of a waste stream and a product stream, as shown in Figure 4.8. There is a variety of different driving forces such concentration, temperature, electric potential behind the separation process. In water treatment, however, most of the membrane processes are pressure driven. Permeable components pass through the membrane and impermeable components are retained on the feed side. Thus, the waste stream contains concentrated impermeable compounds, whereas the product stream is relatively free of impermeable compounds.

There are four major types of membrane processes in water treatment: microfiltration (MF), ultrafiltration (UF), nanofiltration (NF) and reverse-osmosis (RO). These processes vary in types of material they reject, operating pressures, pore size dimensions and separation mechanisms. Furthermore, distinction may be sometimes arbitrary since i.e. pore size ranges are overlapping and the same membrane may be referred to as either a “loose” NF or a “tight” UF. Figure 4.9 gives an overview about different membrane types/definitions with scales for pore sizes and typical water constituents that are removed by the defined definitions.

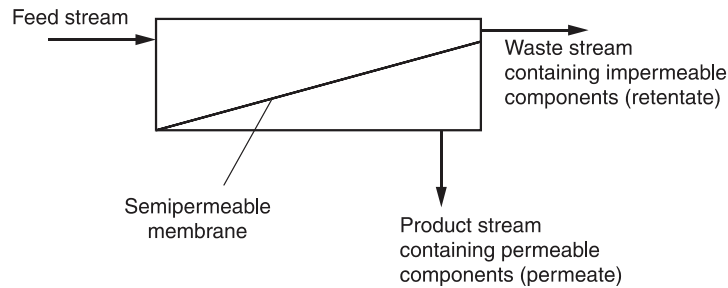

Figure 4.8: Schematic of separation process through a semi-permeable membrane (Crittenden et al., 2005)

The mentioned membrane processes can be categorized by the dominating separation mechanism. MF, UF apply exclusively porous membranes, where basically suspended particles are separated due to size exclusion. They are further operated at rather low pressures below 5 bar, and are therefore often referred to as low pressure membrane filtration. In contrast, in RO dense membranes are applied, having a much higher hydrodynamic resistance making higher operating pressures necessary. Solutes are separated by their ability to diffuse through the membrane. NF is a borderline case since the membranes are almost non-porous and solute mass transport is solution-diffusion controlled. Whereas RO rejects almost all kinds of solutes >98%, NF has a reduced removal capacity of >50% for monovalent ions and microsolute with molecular weights >100 (Mulder, 1996). The information given in the following chapter will mainly discuss low-pressure membrane filtration since this process was investigated in this study, as well as NF to some extent since it is commonly used for NOM removal in Norway.

| Size Range                           | Ionic Range   | Molecular range                        | Macro Molecular Range         | Micro Particle Range                         | Macro Particle range              |
|--------------------------------------|---|--|-------------------------------|--|-----------------------------------|
| Relative Size of Common Materials    | Aqueous Salt<br>Metal Ions<br>Sugar<br>Atomic Radii | Humic acids<br>Viruses<br>Fulvic acids | Clay                          | Bacteria<br>Cryptosp. Oocyst<br>Giardia Cyst | Algae<br>Fine Sand<br>Coarse Sand |
| App. Molecular Weight                | 100 200 1000  | 10,000 20,000                          | 100,000 500,000               |  |                                   |
| Angstrom Units                       | 1 10  | 100                                    | 1000                          | $10^4$ $10^5$                                | $10^6$ $10^7$                     |
| Micrometers                          | 0.0001 0.001  | 0.01                                   | 0.1                           | 1 10   | 100 1000                          |
| Membrane Type and Operating Pressure | Reverse Osmosis<br>10 - 100 bar                     | Nanofiltration<br>3 - 30 bar           | Ultrafiltration<br>>0 - 5 bar | Microfiltration<br>>0 - 2 bar                | Conventional Depth Filtration     |

Figure 4.9: Membrane types compared with scales for pore sizes and particles, after Hendricks (2006)

### 4.5.2 Separation mechanisms

The primary mechanism for removing particles from solution by porous membranes is straining, but it is also influenced by adsorption and cake formation, as illustrated in Figure 4.10. Straining occurs when particles are physically retained because they are larger than the pores in the membrane. If particles, small enough to pass through the membrane, are retained by a cake of larger material that collects at the membrane surface, cake filtration occurs. Adsorption can occur when material small enough to enter the membrane pores adsorbs to the walls of the pores (Crittenden et al., 2005).

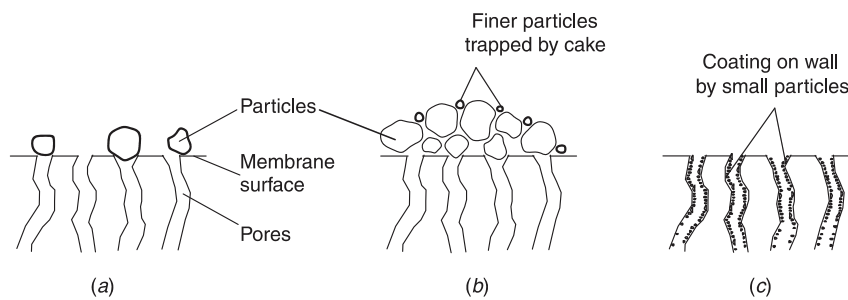

Figure 4.10: Mechanisms for rejection in membrane filtration: a) Straining, b) cake filtration and c) Adsorption (Crittenden et al., 2005).

Especially if substances have dimensions similar to the membrane's pore size, electrostatic interactions, dispersion forces near the pore wall and hydrophobic bonding can strongly affect the rejection. Rejection is normally expressed as a dimensionless ratio, comparing the concentration of a certain constituent in the permeate and in the feed water:

$$R = 1 - \frac{c_p}{c_f} \quad (4.1)$$

Where:  $c_p$  and  $c_f$  are the permeate and feed concentrations.

The flow of water through a MF or UF membrane follows the fundamental law for flow through porous media known as Darcy's law. The standard equation for membrane flow is based on this principle, but it contains volumetric flux  $J$  rather than superficial velocity. Likewise, the driving force is expressed as transmembrane pressure  $\Delta P$  rather than head loss:

$$J = \frac{\Delta P}{\mu R_m} \quad (4.2)$$

Where:  $J$  is the volumetric flux  
 $\Delta P$  the TMP  
 $\mu$  the dynamic fluid viscosity  
 $R_m$  the hydraulic membrane resistance.

In a situation with no fouling, the water flux through the membrane is proportional to pressure gradient and the permeability of the medium. If it is assumed that the flow through the membrane is laminar and equals flow through capillary tubes with the radius  $r_p$ , then Hagen-Poiseuille law describes flux as

$$J = \frac{\varepsilon r^2 \Delta P}{8\eta \tau \Delta x} \quad (4.3)$$

Where:  $\varepsilon$  represents the porosity  
 $r$  the pore radius  
 $\Delta P$  the transmembrane pressure  
 $\eta$  the kinematic viscosity  
 $\tau$  a pore tortuosity factor  
 $\Delta x$  the membrane thickness.

The flux is therefore proportional to the membrane porosity, pore size and the pressure gradient.

### 4.5.3 Membrane materials and structures

Membranes can generally be divided into biological and synthetic membranes, where only the latter is applied in water treatment. Membranes are manufactured from a tremendous range of materials, and they are therefore further divided into the two groups of organic and inorganic. Depending on the material selected, the membranes will have certain properties such as porosity, pore size distribution, wettability, chemical and mechanical stability and so forth. It is therefore crucial to select the most suitable material for the given application. Organic membranes are most common and based on differing polymers and macromolecules. Typical polymers used for the production of microfiltration and ultrafiltration membranes, together with their preparation processes and properties are summarized in Table 4.8.

Table 4.8: Typical preparation processes and raw materials of UF/MF membranes (Kubota et al., 2008)

| Membrane Preparation Process |                                      | Example of Membrane Materials  | UF | MF | Properties   |
|------------------------------|--------------------------------------|--|----|----|--|
| Phase separation             | Nonsolvent-included phase separation | Polysulfone, polyethersulfone, polyacrylonitrile, cellulose derivatives, polyvinylidene fluoride | ✓  | ✓  | Asymmetric structure<br>High permeability<br>High porosity |
|                              | Thermally induced phase separation   | Polyethylene, polypropylene, polyvinylidene fluoride   |    | ✓  | Generally high strength<br>High porosity                   |
| Stretched semicrystalline    |                                      | Polyethylene, polypropylene, polytetrafluoroethylene   |    | ✓  | Slitlike pore  |
| Nucleation track             |                                      | Polycarbonate, polyester   |    | ✓  | Uniformly and straight pore                                |
| Sintered particles           |                                      | Ceramics   | ✓  | ✓  |  |

Not necessarily the same polymeric raw material may be used for MF and UF membranes. Organic microfiltration membranes are normally produced with techniques such as sintering, track etching and stretching, which leads to pores with a minimum size of 0.05 to 1 $\mu$ m. Ultrafiltration membranes cannot be produced in that way, since smaller pores in the nanometre range cannot be obtained with these techniques, thus phase inversion is commonly used for UF membranes (Mulder, 1996). Depending on the polymer used, organic membranes can be further divided into hydrophilic (i.e. cellulose acetate, polysulfone and polyethersulfone) and hydrophobic membranes (i.e. polytetrafluoro-ethylene, polyvinylidene fluoride (PVDF) and polyethylene). Products made from PVDF have shown high strength and high durability in practical operation, which is one of the reasons why the application and production of PVDF membranes has increased during the last years. Furthermore, the thermally induced-phase separation process has become more popular in recent years, since it has an advantage that a high-strength membrane with a high degree of crystallinity can be easily produced. Such membranes may also have a prolonged service life compared to others. This style of membrane is prepared by heating the given membrane to a temperature higher than the melting temperature of the polymer used (Kubota et al., 2008).

Inorganic low pressure membranes are often made of ceramics, glass or metals. Common ceramic materials are alumina ( $\gamma$ -Al<sub>2</sub>O<sub>3</sub> or  $\alpha$ -Al<sub>2</sub>O<sub>3</sub>), titanium dioxide (TiO<sub>2</sub>), zirconium dioxide (ZrO<sub>2</sub>) and ceria (CeO<sub>2</sub>). Other materials used include glass, based

(SiO<sub>2</sub>) or metal based, e.g. sintered steel fibres or powders or thin- or thick-film deposits on various support media (Kennedy et al., 2008).

In addition to the raw material, membranes can be characterized by many other parameters, describing their chemical or physical properties. Such parameters are pore size or molecular weight cut-off, porosity or pore density, pure water permeability, contact angle (hydrophobicity), surface or pore charge and the roughness of the surface. According to Lerch (2008), membranes can be differentiated by the structure of the cross sectional area of the membrane wall, into symmetric and asymmetric types. The resistance to mass transfer in symmetric membranes is determined by the total membrane thickness. In contrast, asymmetric membranes have a change in density of the membrane material across the cross sectional area and the resistance to mass transfer is linked to the resistance of the very dense top or active layer. In some cases the porous structure gradually increases in porosity from the feed to the permeate side of the membrane (Lerch, 2008). If a membrane top layer and support originate from different material they are referred to as composite membranes. This has the advantage that each layer can be optimized independently. Some of these properties are more detailed described in the following chapters in connection with different filtration techniques.

#### 4.5.4 Module and process configurations

Generally membranes are processed as flat sheet or tubular/hollow-fibre. Flat membranes are either used directly in the form of flat sheets or packed together in a spiral-wound form. In the latter, two flat sheets of membrane are separated with a permeate collector channel material to form a leaf. This assembly is sealed on three sides, with the fourth side left open for permeate to exit. A feed/brine spacer material sheet is also included in the leaf assembly. Such a configuration is not well-suited for backwashing and extensive pre-treatment may therefore be necessary. Spiral wound membranes are mainly used in RO and NF systems and not commonly applied in MF and UF applications (Kennedy et al., 2008).

The most common MF or UF membrane configurations today are tubular / hollow-fibre membranes, with fibre diameter varying between 0.5 and 1.5 mm (max 5 mm). Several thousands of such fibres may be packed into modules, such as pressurized cartridges as for example shown in Figure 4.11. With this design, a significant portion of membrane area can be assembled per square meter of footprint, and depending on the fibre diameter, packing densities up to a few 1000 m<sup>2</sup>/m<sup>3</sup> can be reached (Melin and Rautenbach, 2004). Such modules are normally arranged vertically, but horizontal configurations are also available. Manufacturers of such systems include Pall, X-flow, Inge AG, GE Water, Koch Membrane Systems, Hydracap and Lenntech.





Figure 4.11: Ultrafiltration cartridge with hollow fibres (courtesy of Koch Membrane Systems, Inc.)

Membranes can be operated in different flow modes, such as outside-in and inside-out, depending on the flow direction of the filtration flow. Furthermore, the pressure differential driving force can be generated by pressurizing the membrane module or alternatively by applying a vacuum on the permeate side of the membrane. In inside-out configuration, the feed water is forced into the fibre through the bore and permeate is collected on the outside of the fibre (Figure 4.12), while the opposite is the case for the outside-in configuration. In this configuration, feed is pressurised and forced through the outer fibre surface into the lumen, permeate is collected at the bore. Pressure vessels can be designed to use either outside-in or inside-out membranes, while submerged/vacuum systems use only outside-in membranes. In theory, outside-in systems are able to treat more water since the outer surface area is bigger compared to the inside surface. Moreover, the setup is less sensitive to clogging by big particles (Crittenden et al., 2005).

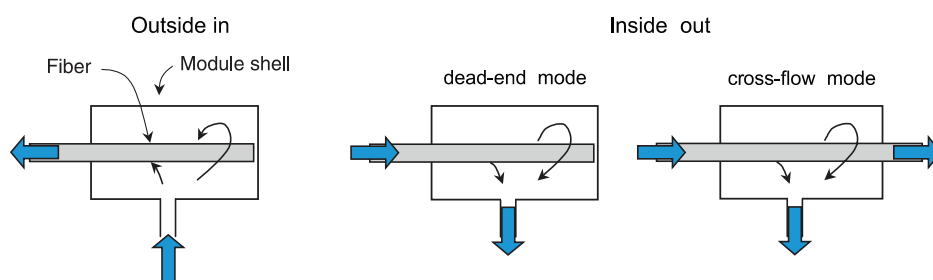

Figure 4.12: Different membrane configurations exemplary for hollow fibres (Crittenden et al., 2005)

As indicated in Figure 4.12, there are two different principle process configurations: dead-end operation and cross-flow. In cross-flow filtration, feed water is pumped at a

high rate through the lumen of fibres, parallel to the membrane surface. The cross flow is normally about four orders of magnitude higher than the superficial velocity of the water towards the membrane surface. The velocity parallel to the membrane surface creates a shear force that reduces the development of a surface cake (Wiesner and Chellam, 1992). The concentrate is recirculated into the feed water, increasing drastically the energy demand. Thus, cross-flow operation is more energy intensive by a factor of 10 to 14 compared to dead-end filtration (Melin and Rautenbach, 2004). As another consequence, the solids content of the feed water increases due to the recirculation. In order to control the solids concentration, a certain percentage of the concentrate must be discharged. In contrast to cross-flow operation, all water passes through the membrane in the dead-end mode of operation. However, a certain percentage of the permeate is used for backwashing and the total recovery is therefore typically below 100%. Even though in dead-end mode there is a feed water flow tangential to the membrane surface, the velocity is much smaller compared to cross-flow operation.

In addition to the direction of the filtration flow, operation of membranes can be distinguished if it is pressure controlled or flux controlled. According to Doyen (1997) has each of these operation modes its strengths and weaknesses. If a fresh membrane is operated in the flux controlled mode, this results typically in low fouling since not all of the available pressure is applied. This can be seen as a loss of pressure or pressure capacity, leading to higher energy losses. The authors concluded further that “if the membrane is completely fouled, it will be exposed to the total available TMP. At that time the fouling layer will be strongly compressed, which is a disadvantage for its removal. On the other hand, operating in pressure controlled mode, with a clean high pure water flux membrane, leads to severe fouling because excessive flux rates may be used.” (Doyen, 1997). However, once the membrane is fouled, the fouling layer will not be compressed and the energy consumption with this operational mode will be lower.

Tubular membranes are another form of membrane configuration. They can be seen as large hollow fibres, with diameters between 5 to 25 mm. Due to this, they are less prone to clogging, can tolerate high levels of suspended solids and are relatively easy to clean. However, the packing density is lower (below  $200 \text{ m}^2/\text{m}^3$ ) and the feed flow rate is higher per membrane area (Melin and Rautenbach, 2004).

Multi-bore or monolith configurations can be considered as an advancement of hollow fibre membranes. Several capillaries are arranged within a monolith block. This design is often used for ceramic membranes. An example is shown in Figure 4.13. Such a system has a much higher breaking resistance compared to single fibres. The ceramic membrane applied in this study is of monolith type and described further in Chapter 5.2.

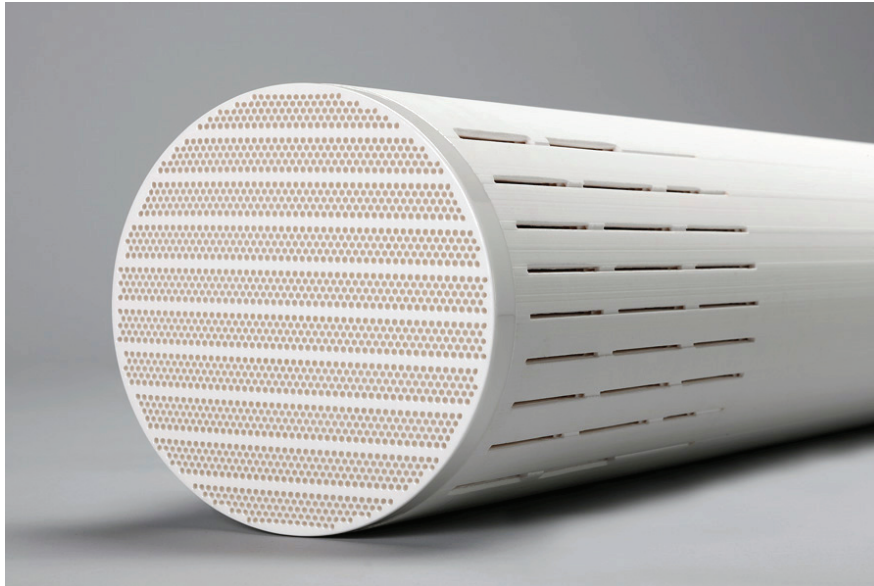

Figure 4.13: Metawater's 3<sup>rd</sup> generation monolith ceramic microfiltration membrane, with 2000 channels and 25 m<sup>2</sup> surface area (courtesy of Metawater Co., Ltd., Japan)

In recent years hollow fibre membranes are increasingly prevalent on the market. One reason for that may be the possibility of automated backwashing with permeate, reducing the need for extensive pre-treatment. Furthermore, there appears to be a shift from cross-flow to dead-end filtration in water treatment applications, which leads to huge energy savings due to the elimination of the feed water recirculation, which is common in cross-flow operation. Such configurations can be efficiently backwashed with permeate, fully automated in certain time intervals (Kennedy et al., 2008). This mode of operation is described further in Chapter 5.2. Although polymeric membranes still dominate the water treatment industry, the application of ceramic membranes has gained a lot of ground in recent years. The development of multi-bore membrane systems combined with new process configurations and the excellent material properties offered by ceramic materials have made them a realistic commercial alternative solution for advanced water treatment using membrane technology.

#### 4.5.5 Membrane fouling

Fouling is apparently the most significant issue affecting the design and operation of membrane filtration facilities. Kennedy et al. (2008) defines it as the blockage of membrane pores during filtration caused by the combination of sieving and adsorption of particulates and compounds onto the membrane surface or within the membrane

pores (Figure 4.14). Some pores may be completely sealed by incoming particles while others are fouled because of the reduced cross-sectional area due to particles or dissolved matter which adsorbs to the pore walls. Furthermore, a gel or cake layer may form on the membrane surface, increasing the overall resistance. Fouling leads to flux decline over time when all operating parameters such as pressure, flow rate, temperature, and feed concentration are kept constant. The degree of membrane fouling depends on a variety of process parameters and conditions, i.e. the membrane properties (morphology, roughness, structure, physical and chemical properties), the module configuration (hydraulic configuration, packing density, void zones, backwashability), cleaning procedures, (frequency, chemicals), operating conditions (pre-treatment, pH value, temperature, flux) and the properties of the treated fluid (constituents, origin). Fouling can be characterized by whether it can be removed (i.e., reversible, irreversible), by the material causing it (i.e., particulate, dissolved, inorganic, organic, biological), or by the mechanism (i.e. cake formation, pore blockage). Different kinds of foulants are of importance in practise. They can be classified depending on their origin into inorganic-, particulate-, biological- and organic fouling.

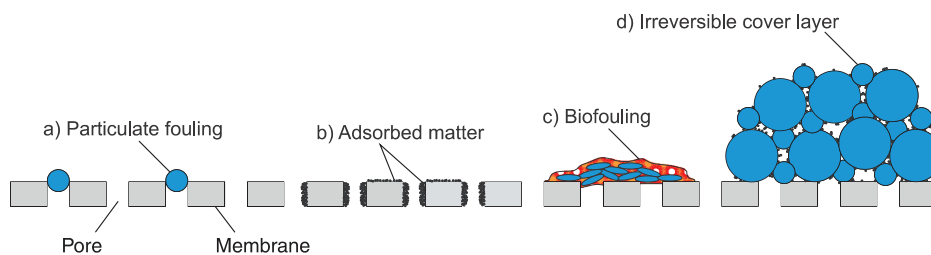

Figure 4.14: Different fouling mechanisms: a) pore blocking, b) pore constriction, c) biological fouling and d) cake or gel layer formation (adapted from Melin and Rautenbach (2004) and Crittenden et al. (2005)).

*Inorganic fouling or scaling* is caused by accumulation of inorganic material on the membrane surface or within the pore structure. Metal hydroxide and metal oxide particles have the tendency to agglomerate, which may lead to deposition and the formation of a gel layer on the membrane surface, if their concentration is high to overcome their charge induced stability. Scaling in a classical sense, where salt crystals are formed due to oversaturation, is not observed in MF or UF, since these substances are not retained by these techniques (Melin and Rautenbach, 2004).

*Particulate and colloidal fouling* may be caused by biologically inert particles and colloids that are inorganic in nature and originate from the weathering of rocks, i.e. by silt and clay. Such particles and colloids accumulate on the membrane surface during operation and cause a decline in flux. This accumulation is reversible by backwashing to a large extent. However, such a cake may be compressed other times and together with

other deposited foulants an irreversible cover layer may form. Fouling may be especially severe if the size range of colloids falls within the same order of magnitude as the membrane pores. As a result, rapid permeability decline occurs due to pore plugging.

*Biological fouling* is often a result of the formation of a biofilm on membrane surfaces. Such a growth is typically accompanied with production of extracellular polymeric substances (EPS), in which microorganisms are embedded in. EPS is a viscous, slimy, hydrated gel, which typically consists of hetero-polysaccharides. Biopolymers released from the biofilm, such as polysaccharides, proteins and amino sugars, also contribute to the fouling.

*Organic fouling* can be often found when natural waters containing numerous organic components provoke membrane fouling. Such components can be largely contributed to NOM, comprising of macromolecular fragments and metabolites from plants, algae and microorganisms as well as humic substances. Since NOM is rather heterogenic in surface water, this fouling type is more difficult to control and predict. Membrane fouling by NOM has been the subject of numerous publications. Since the fouling mechanisms of NOM are manifold, such as the composition of NOM itself, available membrane materials, process configurations, solution chemistry this type of fouling can manifest itself in many ways. This complexity and variation in analytical methods has resulted in that findings from these studies are not consistent, partially contradicting, and therefore difficult to compare.

Jucker and Clark (1994) ascertained that hydrophobic humic acid adsorbs to the membranes they studied to a greater extent than fulvic acid. Reasons for this may be the tendency of hydrophobic compounds to adhere to surfaces in order to minimize water contact. Similar results were reported by Schäfer et al. (2000) and Aoustin et al. (2001), who concluded that the larger and more UV-absorbing fraction of humic acid was shown to be responsible for irreversible pore adsorption and plugging, while the fulvic acid and the hydrophilic fraction showed a smaller and mostly reversible flux decline. In contrast, Carroll et al. (2000) identified the smaller, neutral hydrophilic NOM fraction as the major fouling component. Similar results were published by Lin et al. (2000). Others have identified polysaccharide-like substances as the NOM component causing the most fouling. To add to this, other studies published a fouling ranking of different NOM components, where the fouling declined in the following order neutral hydrophilics > hydrophobic acids > transphilic acids > charged hydrophilics (Cho et al., 2000; Fan et al., 2001). Howe and Clark (2002) and Makdissy et al. (2003) pointed out that the organic colloidal fraction may cause the most significant fouling compared to the dissolved fraction. Though much knowledge has been gained, membrane fouling by NOM is therefore still not fully understood.

In addition to various possible foulants, different fouling mechanisms have been reported as well. Lahoussine-Turcaud et al. (1990) and Crozes et al. (1993) reported that fouling by organic matter was attributed to adsorption of organic compounds, and was not reversible by hydraulic cleaning. In contrast, Yuan and Zydney (1999b) attributed fouling of a microfiltration membrane by commercial humic acid solutions to formation of a surface deposit retained rather than adsorption within the pore space. Furthermore, NOM fouling was found to be dependent on the solution chemistry. Multivalent ions, especially calcium, have the ability to enhance adsorption by reducing the solubility of NOM. Such ions may form intermolecular bridges or bridges between the negatively charged NOM and the membrane surface (Jucker and Clark, 1994; Hong and Elimelech, 1997; Yuan and Zydney, 1999a). As described earlier, the charge density of NOM depends on the solution pH. If that is low, the charge density declines, reducing the electrostatic repulsive forces and more adsorption is allowed and membrane fouling may increase (Jucker and Clark, 1994; Yoon et al., 1998; Jones and O'Melia, 2001). Generally, hydrophilic membranes may be less prone to fouling by adsorption of organic matter due to higher charge repulsion, compared to hydrophobic membranes (Lainé et al., 1989).

A comprehensive study of NOM fouling on low-pressure membrane systems was published by Lozier et al. (2008). Various raw waters containing different types of NOM were investigated, in combination with various membrane materials (PVDF, PAN, PES), pore sizes (MF, UF), module configurations (flat sheet, hollow fibre) and process scales (bench-, pilot- and full scale). Different analytical techniques were employed for the characterisation, such as SEC-DOC, FEEM, resin fractionation, Fourier transform infrared spectroscopy (FTIR), pyrolysis GC/MS etc. Different statistical methods were applied, in order to verify and describe the relationships and effects observed. Similar to other studies, polysaccharide- and protein-like NOM were identified as the most problematic foulants. They occurred in both macromolecular and colloidal form. Feed waters dominated by these NOM constituents generally exhibited lower SUVA values than those dominated by humic substances. A low SUVA may thus be a first warning sign of fouling potential. Protein-like NOM also is manifested in a higher Dissolved Organic Nitrogen (DON) level while polysaccharide-like NOM is also captured by a higher hydrophilic DOC level after resin fractionation. The presence of polysaccharide-like and/or protein-like foulants is more pronounced in NOM of a microbial origin, i.e., autochthonous/algal organic matter or effluent organic matter than in allochthonous (terrestrial) NOM. Lozier et al. (2008) stated further that even though the NOM character is more important than amount, allochthonous sources with a high DOC level can still cause significant fouling. The highest degree of hydraulically irreversible fouling appears to be caused by allochthonous NOM. Polysaccharide-like foulants can interact with a membrane through either hydrogen bonding due to their neutral character. If present in a colloidal form, they may contribute to cake or gel layer

formation, which is not well hydraulically reversible. Protein-like foulants have an amphoteric character and may interact with the membrane surface by dipole interactions. If they are in colloidal form, protein-like foulants may contribute to a cake or gel layer. Albeit it was not thoroughly investigated, membranes with negative zeta potential experience lower fouling by NOM. In order to reduce fouling, coagulation/flocculation pre-treatment was recommended: “Coagulation/ flocculation can remove polysaccharide- and protein-like NOM; at high coagulant doses, clarification may be necessary. However, if NOM fouling is hydraulically reversible, then coagulant addition may simply lead to added resistance and an associated decrease in permeability.” (Lozier et al., 2008). In contrast to other studies, it was concluded that the presence of calcium, unlike its adverse effect on NOM fouling of high pressure membranes, does not appear to be an influential factor in NOM fouling of low-pressure membranes. This was explained by the not inherently retention by MF/UF membranes.

MF and UF are drinking water treatment processes that are particularly suitable for the removal of suspended solids and colloidal materials but less successful for the removal of dissolved contaminants, such as NOM in surface water. Therefore, coagulation was introduced to address this weakness as it has proven to be effective for decreasing hydraulic resistance, increasing critical flux and improving NOM removal (Zularisam et al., 2006). Low pressure membrane filtration is further discussed in Chapter 4.5.6.

Membrane fouling may be *reversible* or *irreversible*. Reversible fouling refers to increased membrane resistance which can be removed by hydraulic backwash. As illustrated in Figure 4.15, the TMP is increasing with progressing operation in dead-end filtration due to accumulation of a cake on the membrane surface. At certain intervals a cleaning is performed, usually by backwashing, removing the cake layer deposited and the TMP partially recovers. Over time, not all fouling can be removed and the initial TMP level is not reached. Once the fouling exceeds a certain threshold, a chemical cleaning is carried out. Such a cleaning is normally able to restore more permeability compared to a normal backwash. Fouling which can be eliminated by chemical cleaning is referred to as chemically reversible fouling. However, fouling which cannot be eliminated by normal or chemical cleaning is referred to as irreversible fouling.



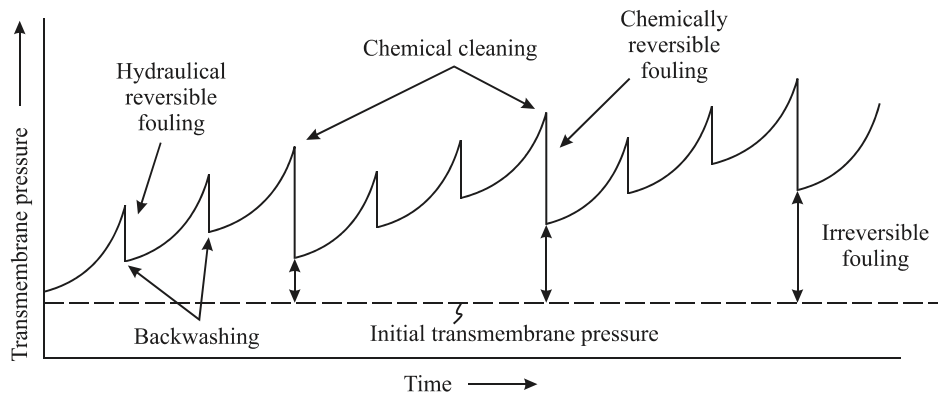

Figure 4.15: Schematic of partial restorations of TMP by normal or chemical enhanced backwashing in a pressurised system operated in constant flux and dead-end mode (Davis, 2010).

Different kinds of chemical cleanings can be found in practise. Chemical enhanced backwashing (CEB) is an enhanced form of the conventional backwash procedure. Chemicals are dosed into the backwash water and instead of a rapid backwash, the membrane is soaked in the chemicals-water mixture for a couple of seconds or minutes. After that, the backwash solution is flushed out together with detached or dissolved foulants by a conventional backwash. A CEB is performed fully automatic in regular intervals, usually a couple of times per week. Typical chemicals used are acids and bases like citric acid, hydrochloric acid, sulphuric acid or sodium hydroxide. Once or twice a year a more intensive cleaning is performed, often in-situ, and referred to as cleaning in place (CIP). A CIP may be more labour and time intensive, and typically needs a shutdown of the production. Chemicals used are often different cleaning solutions, oxidants like sodium hypochlorite, hydrogen peroxide as well as citric acid, hydrochloric acid, sulphuric acid or sodium hydroxide. After such a cleaning the membrane performance is often restored to the original level.

In reality, different fouling mechanisms are going to occur simultaneously. The resistance-in-series theory is often used to describe fouling phenomena and as a means to assess and model membrane performance when taking into account fouling (Crittenden et al., 2005). In order to accommodate that, the resistance in series model applies a resistance value to each fouling component. It assumes that each component contributes to hydraulic resistance and that they act independently from one another. The model can be further extended by a resistance term for concentration polarisation, which is the gradual increase in concentration of accumulated substances at the membrane surface forming a boundary layer. By neglecting the osmotic pressure Equation (4.2) can be modified to



$$J = \frac{\Delta P}{\mu(R_m + R_{cp} + R_c + R_a)} \quad (4.4)$$

where:  $R_m$  represents the membrane resistance  
 $R_{cp}$  the resistance due to concentration polarisation  
 $R_c$  the cake layer resistance  
 $R_a$  the resistance caused by adsorptive fouling.

In low pressure filtration the dominating fouling mechanisms are cake layer formation pore blocking and adsorptive fouling. Concentration polarisation presents normally a negligible resistance in low-pressure filtration. At high pressures however, the resistance of the boundary layer may be large.

In practise, tools are needed for the prediction of membrane fouling potential by a certain feed water. Such tools are ideally based on simple and quick measurements, which can be carried out on-site or in the field. Therefore, different fouling indices have been developed in the past. An overview of such indices can be found in Kennedy et al. (2008). Commonly found are the silt density index (SDI), modified fouling index (MFI), mini-plugging factor index (MPFI) and the MFI-ultrafiltration (MFI-UF). The SDI is a commonly used test to predict the fouling by colloidal particles smaller than 0.45  $\mu\text{m}$ . The SDI test is performed by timing the flow through a 47 mm diameter, 0.45  $\mu\text{m}$  membrane filter, at a constant pressure of 30 psi. In order to estimate the fouling status of the membrane the filtration time for 500 mL of the feed water is measured at the beginning of the test and also after certain time intervals after the start. The SDI test is not based on any filtration mechanism and has no linear correlation with colloidal matter concentration. Thus, even though a rather low SDI is found, serious fouling may occur. The  $\text{MFI}_{0.45\mu\text{m}}$  is determined by using similar equipment and procedure used for the SDI, however, the volume is recorded every 30 s over a 15-min filtration period. In contrast to SDI, MFI is has the cake filtration mechanisms as base. It is further linearly related to the concentration of colloidal matter and can utilize membranes of different sizes. To incorporate also smaller particles in the MFI, ultrafiltration membranes can be used for measuring the MFI instead of the 0.45  $\mu\text{m}$  membrane discs, giving the MFI-UF (Kennedy et al., 2008). Because the traditional modified fouling index (MFI) was developed for constant pressure filtration, the concept of a unified MFI (UMFI) was derived to quantify the fouling rate encountered not only in constant pressure, but also in constant flux filtration (Lozier et al., 2008). The UMFI provides a basis for comparison of results derived from different units and different scales. UMFI values can be derived from a data plot of inverse normalized specific flux versus the hydraulic throughput. Several versions of the UMFI are in use.

#### 4.5.6 Membrane processes relevant for treatment of Nordic waters

In Norway, there is a tradition for using nanofiltration in the treatment of low turbidity and alkalinity waters, with a high colour and DOC content. Although scarcely applied in practise until recently, alternative membrane processes are emerging, such as low pressure filtration coupled with coagulation pre-treatment.

##### 4.5.6.1 Nanofiltration

With respect to removal of organic substances, nanofiltration (NF) ranges between RO and UF. While RO achieves almost 100% retainage of substances with a molecular weight of 150 g/mol, NF does not achieve noteworthy removal until a molecular weight of 200 g/mol is reached. The term “nanofiltration” is derived from the fact that molecules with a molar weight of 200 g/mol have approximately the size of 10 angstrom, which corresponds to 1 nanometre. Nanofiltration is also able to retain certain salts. Salts with monovalent ions can pass the membrane, but not unhampered. Salts with multivalent ions are retained much more efficiently. Especially the valence of the anion is important for the permeability of a salt (Melin and Rautenbach, 2004). Nanofiltration membranes typically have a MWCO between 200 and 2000 Dalton with pore sizes usually below 2 nm. Nanofiltration membranes are often manufactured by phase inversion, resulting in homogeneous and asymmetric membranes, often made of cellulose acetate or poly(ether)sulfone. A common alternative production method is interfacial polymerization, which produces heterogeneous membranes, consisting of a thin-film composite layer on top of a substrate UF layer. Typical polymers used in this second process are polyamides (often with aromatic moieties), polysulfone and so forth. Most NF membranes are constructed as spiral-wound elements. However, hollow-fibre, and flat-sheet or plate-and-frame modules are also available (Mulder, 1996; van der Bruggen and Geens, 2008).

Today, around 110 nanofiltration plants are in operation in Norway, removing colour from surface water. Most are very small with 47% of the plants have a capacity up to 10 m<sup>3</sup>/h, and 51% up to 100 m<sup>3</sup>/h. A few larger plants have a capacity of up to 700 m<sup>3</sup>/h. Spiral-wound membrane modules made of cellulose acetate are commonly used, with pore sizes between 1 and 5 nm. The membrane unit is preceded by a 50- $\mu$ m automatically backwashed micro-sieve or cartridge filter, or less commonly by a rapid sand filter. Standard 8"-spirals in lengths of 1 or 1.5 m mounted into 4-6 m long element housings are mostly used. Figure 4.16 shows the flow sheet of a typical nanofiltration plant. Such plants are operated at membrane fluxes between 12 to 20 L/(m<sup>2</sup> h) with a cross flow velocity around 0.2 m/s, which represents equal volumetric flows for the feed and recirculation stream. Recovery rates of up to 70% can be normally achieved, in some cases up to 80% have been reported. Normal operating pressures are ranging from

4 to 8 bar. A daily chemical washing cycle is necessary, typically with alkaline and chlorine wash. Main CIPs are performed once or twice per year. In spite of the frequent chemical cleanings, a rapid performance loss is a common problem, resulting in pressure increase and sometimes a need for bypassing to meet water demands. The reasons for this are manifold. Often, raw water quality varies throughout the course of a year, causing seasonal fouling effects that may be irreversible. Pre-treatment may not be sufficient upfront the nanofiltration. Furthermore, operation may not be optimised and performance loss occurs due to too high design fluxes, too low cross-flow velocity, inefficient cleaning protocols, shortcomings in plant design and the lack of supervision/performance evaluation (Thorsen, 1999; Machenbach and Thorsen, 2006; Ødegaard et al., 2010).

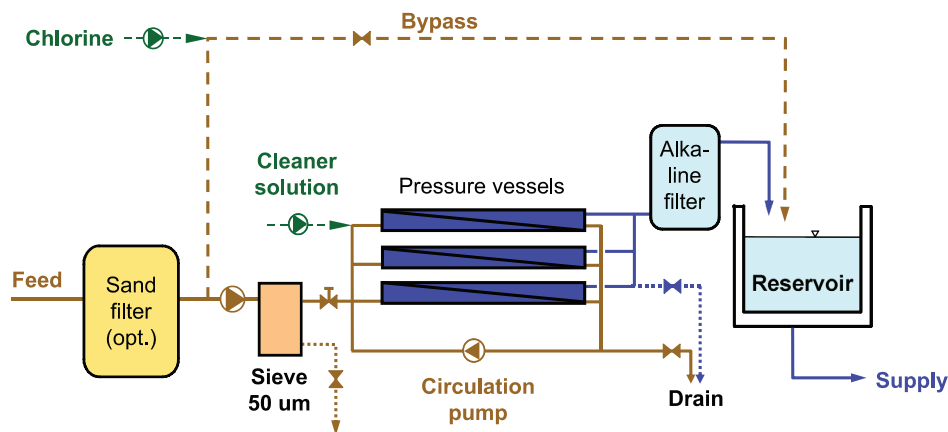

Figure 4.16: Typical nanofiltration plant flow sheet (Machenbach and Thorsen, 2006)

Hem (2008) published data based on a survey of the operating experiences of the Norwegian water treatment plants using nanofiltration for the removal of humic substances, conducted in 2006 and 2007. According to the report, in each year more than 50 % of the plants have experienced colour levels  $> 5$  mg Pt/L and more than 30 % of the plants have experienced colour levels  $> 10$  mg Pt/L in the effluent. As already mentioned in Chapter 2.2, the limiting value for colour in the Norwegian guidelines is defined at 20 mg Pt/L, however, values below 5 mg Pt/L are regarded as good operating practise, if coagulation with metal salts is used as treatment scheme. Furthermore, *E. coli* was detected in treated water once or more at 31 % of the waterworks in a period from 2001 to 2005, where some of the plants did not have appropriate disinfection installed. However, the percentage of the plants with at least one sample with plate counts higher than 100/mL seemed to be independent of whether the plants had UV disinfection or not, and no relation between raw water and treated water plate counts could be established. It was concluded that a possible higher microbiological growth may originate from the treated water and not necessarily from the nanofiltration itself.

Summarising, Table 4.9 shows common advantages and disadvantages of nanofiltration applied for Nordic water treatment.

Table 4.9: Advantages and disadvantages of nanofiltration

|   |  |   |  |
|---|--|---|--|
| + | Generally good permeate quality                                      | - | High energy consumption due to higher operating pressure and intensive recirculation   |
| + | Hygienic barrier against all kinds of pathogens                      | - | Low operating fluxes and low recovery  |
| + | Robust against changes in the raw water quality                      | - | High chemical demand for membrane cleaning   |
| + | Fully automated plants - ease of operation for decentralized systems | - | Reduction of hardness and alkalinity, additional corrosion control therefore necessary |
| + | No chemicals added to the water                                      |   |  |
| + | Edificial simple   |   |  |

#### 4.5.6.2 Low pressure membrane filtration: MF and UF

Membranes used for MF and UF are unexceptionally porous. If a particle is retained, it depends mainly on its size and structure relatively to the size and structure of the membrane pores, although operating conditions certainly have an. As also seen in bench or cake filtration, retained substances may deposit on the membrane surface similar to a filter cake, and an increased filtration efficiency may be observed from the dynamic layer formed. Such phenomena may lead to improved separation efficiencies that may include removal of viruses, even though this is not expected with MF membrane filtration due to the rather large pore sizes of such membranes. However, viruses can be completely removed by UF membranes. MF membranes have a pore size range from around 0.08  $\mu\text{m}$  up to 10 $\mu\text{m}$ . The pore size distribution varies and can be narrow or wide, depending on the type and properties of the membrane. Therefore, a nominal pore size is normally given which corresponds to the diameter of a characteristic particle which is retained by 95 to 98 % by the membrane. Pore sizes of UF membranes are often described by the size of molecules they can retain, instead of a true pore diameter. Typical MWCO of UF membranes are in the range from 1000 to roughly 10,000 Dalton, with pore sizes ranging from 1 to 100 nm (Mulder, 1996; Melin and Rautenbach, 2004).

Since direct application of MF and UF for the treatment of natural waters often goes along with severe membrane fouling, different pre-treatment schemes are commonly found in practise, such as various forms of coagulation and flocculation, adsorption, magnetic ion exchange or ozonation. As already discussed in chapter 4.5.5, NOM is removed to a small extent by MF and UF alone and usually causes extensive fouling

(Cho et al., 2000; Lin et al., 2000). However, with coagulation pre-treatment this may be reduced or even overcome, as for example in the scheme proposed by Lahoussine-Turcaud et al. (1990) or Gray et al. (2007). Coagulation pre-treatment together with low-pressure membrane filtration is therefore discussed in the next chapter.

#### 4.5.6.3 Low pressure membrane filtration with coagulation pre-treatment

Analogue to membrane fouling by NOM, numerous publications have investigated the effect of coagulation pre-treatment on the filtration performance (reversible and irreversible fouling, DOC and colour removal, residual metal), in dependence on the coagulation and flocculation conditions (coagulants, dosages, pH-values, type of mixing, mixing intensity, flocculation type, flocculation time etc.) or the membrane configuration (membrane materials, pore sizes, module design, backwashing). Coagulation may be used as the only pre-treatment, but is occasionally followed by sedimentation, flotation or rapid sand filtration. Different kinds of raw waters have been investigated, including artificial raw waters containing various commercial NOM standards, but also waters from reservoirs, lakes, rivers and channels around the world, which are often used as sources for potable water production. It is generally accepted that coagulation pre-treatment for low-pressure membrane filtration minimises fouling and enhances NOM removal (Lainé et al., 1989; Lahoussine-Turcaud et al., 1990; Peuchot and Ben-Aim, 1992; Carroll et al., 2000). Contrarily, other researchers have found that coagulation makes fouling worse, usually depending on operating conditions (Schäfer et al., 2000; Judd and Hillis, 2001; Howe and Clark, 2006). Nevertheless, coagulation coupled with MF/UF has become a standard process for drinking water treatment. Whereas in 1996 only a few full scale plants<sup>3</sup> were in operation, there were approximately 90 in 2005 with a total treatment capacity of 73,000 m<sup>3</sup>/h. This corresponds to about 14 % of the MF/UF plants installed worldwide and about 22 % of the total potable water produced by MF/UF plants.

As described in Chapter 4.5.5, some fractions of NOM severely contribute to membrane fouling. If these fractions could be transformed by coagulation into easily separable flocs, these substances could not interact with the membrane anymore. Thus the adsorptive fouling potential is reduced and NOM removal is greatly improved. This may be of importance since, besides colour and DOC, also precursors for disinfection by-products are removed if enhanced coagulation strategies are applied. On the other hand, charged metal species found in coagulated water may interact with the membrane and aggravate the membrane fouling, in a similar manner as for example calcium ions do. Furthermore, increased solids loading may reduce membrane fluxes and increase cleaning requirements. However, a fouling layer formed by coagulated material has

---

<sup>3</sup> Plants with a treatment capacity of more than 8 m<sup>3</sup>/h

ideally a lower resistance compared to layers formed by smaller, un-coagulated particles and colloids (Lahoussine-Turcaud et al., 1990; Howe and Clark, 2002; Cho et al., 2006). Such a layer may further act as a second dynamic separation layer, protecting the actual membrane from foulant attachment. As for all coagulation processes, a hybrid coagulation membrane filtration process produces a chemical sludge which will require a form of disposal. Even though there are many studies that investigated NOM fouling, only a few actually focus on NOM removal where important issues related to coagulation are often neglected, such as residual metals in the permeate.

Various studies have shown that coagulation has improved membrane performance. Terminal flux of synthetic lake water through regenerated cellulose (RC) membranes increased from 20% of initial flux without coagulation to 60% of initial flux with coagulation using 60 mg/L of PACl (Lainé et al., 1989). Lahoussine-Turcaud et al. (1990) evaluated the effect of coagulation pre-treatment on UF of surface water using a hydrophobic polysulfone membrane. Coagulation did neither change the extent nor the rate of the irreversible fouling. Only the short-term reversible fouling was reduced. This was explained by the preferential removal of the larger sized foulants which are causing often the reversible fouling. The smaller foulant fraction, normally responsible for the irreversible fouling, was not efficiently removed. Factors like coagulant dosage, pH, nature of dissolved organic matter, as well as the  $\text{Ca}^{2+}$  content of the feed water had a significant effect on membrane fouling. Carroll et al. (2000) found that pre-treatment with 35 mg/L of alum reduced fouling of a polypropylene MF membrane. The smaller sized hydrophilic NOM was identified as the major foulant after coagulation, which is consistent with studies presented in Chapter 4.5.5. Problematic in this connection is the fact that most metal-based coagulants are known to preferentially remove hydrophobic rather than hydrophilic substances, and foulant removal is therefore insufficient.

It has been shown that the permeability of the cake deposited on a microfiltration membrane can be conditioned chemically by controlling the pH and coagulant dose in flocculation. Wiesner et al. (1989) investigated the microfiltration of with PACl coagulated humic acid solutions (polycarbonate membranes with pore diameters ranging from 0.1 to 5  $\mu\text{m}$ ). The maximum permeability occurred when the particle size was maximised. This was found to be the case when the zeta potential of the flocculated suspension was near zero. Depending on the coagulant dosage, this optimum and thus the point of zero charge was found at different pH-values. For a PACl dose of 2.7 mg Al/L the point of zero charge (PZC) was around pH 7, at a dose of 6.8 mg Al/L the PZC was around a pH of 8 respectively. The lower coagulant dosage produced a more permeable cake at optimal conditions than the higher dosage. Lee et al. (2000) investigated coagulation of reservoir water before an outside-in MF system (dead-end and cross flow). They found the lowest specific cake resistance to be at charge neutralisation conditions (pH 5, 0.2 to 0.8 mg Al/mg C), compared to conditions for

sweep coagulation (pH 7 to 8, 0.4 to 6.1 mg Al/mg C). Since the particle size of the created flocs was rather similar with both coagulation mechanisms, it was concluded that a different cake compressibility was the reason for the different specific cake resistance observed. Lee et al. (2000) showed that flocs formed by the sweep-floc mechanism have a much lower density than those formed by the charge neutralization mechanism due to their relatively higher water content. They are further “gel like, more compact, and less porous because they are made up mostly of the aluminium hydroxide precipitates. On the other hand, flocs formed through the charge-neutralization mechanism consist of complexes of aluminium cations, inorganic colloids, and/or organic substances, and thus they are less compressible” (Lee et al., 2000). Similar results have been published by Antelmi et al. (2001) and Cabane et al. (2002). Judd and Hillis (2001) investigated an inside-out hollow fibre MF of surface water coagulated with iron salts. The plant was operated at pH 5.5, varying the dosage from 1 to 4 mg Fe/L. At low coagulant dosages the specific cake resistance increased. After exceeding a threshold dosage, the specific cake resistance decreased with increasing dose and was almost zero at maximum dose (4 mg Fe/L). Zeta-potential measurements showed zero charge at the point with the lowest cake resistance. In comparison to Wiesner et al. (1989), the authors found the effect of the iron dose on the cake permeability was much more significant compared to a pH effect for coagulation with PACl. Furthermore, flocs need to reach a certain critical floc size prior to MF, otherwise membranes would be irreversibly fouled by the coagulant solids. The effect that the coagulant dose determines if coagulation pre-treatment may have an advantageous or detrimental influence on the filtration performance is consistent with the literature (Howe and Clark, 2002, 2006).

A decrease of the specific cake resistance with increasing coagulant dose was also reported by Pikkarainen et al. (2004). Coagulation pre-treatment was investigated, comparing four different aluminium and iron based coagulants for treatment of coloured surface water (DOC  $\approx$  6 mg/L, SUVA from 4.74 to 5.71 L·(m·mg C)<sup>-1</sup>) by MF. The hydraulic resistance properties were similar for all coagulants, but the rate of change of the resistance with coagulant dose differed slightly between iron and aluminium coagulants. Unfortunately no results of charge measurements were given, but the results presented correspond well with earlier findings from Judd and Hillis (2001). The low molecular weight DOC fraction was not sufficiently removed by all coagulants and was further not improved by cake development. Ferric chloride was the most effective in removing of intermediate molecular weight organic matter. The optimal DOC removal was found at a pH of 4.7 for ferric chloride and at around 6 for the two investigated aluminium coagulants, PACl and ALS. Since no increased DOC removal was found at flocculation times greater than 30 s, it was concluded that the particles had grown sufficiently large to be removed by the membrane. Guigui et al. (2002) studied inline coagulation prior to a UF process in order to improve membrane performance and water



quality for surface water treatment (DOC 3.9 mg/L,  $UV_{254}$  7.2  $m^{-1}$ ). Three coagulants were investigated, PACl, ALS and FeCl. The permeate quality increased by applying coagulation pre-treatment, which also controlled the amount of DOC removed. Membrane fouling could be reduced, however, if the coagulation is insufficient the remaining un-coagulated material may induce fouling. At the same metal cation concentration (mol/l), ferric chloride was found to give higher NOM removal compared to other coagulants. Furthermore, no optimal coagulant dose was found and NOM removal increased with the increase of coagulant dose up to a stable level.

Due to the different pore size distribution, UF and MF may have different requirements to coagulation pre-treatment, as for example shown by Howe et al. (2006). The study examined the fouling of MF/UF membranes by natural waters (Clackamas River water with low alkalinity, low hardness, low TOC and high SUVA) with and without coagulation by specific fractions of constituents in natural water, separated by size. The microfiltration of raw water without coagulation led only to relatively little flux decline. However, the flux declined substantially after applying coagulation with either alum or ferric chloride. The opposite behaviour was found for UF. The same coagulants and doses were used in both cases. According to Howe et al. (2006), these results clearly indicate differences in the mechanisms of fouling between MF and UF membranes. The pores of MF membranes are an order of magnitude larger than the pores of UF membranes, so foulants capable of clogging MF membrane pores might merely form a cake layer on a UF membrane.

Since ceramic membranes are becoming increasingly competitive, more popular and may be seen as an alternative to polymeric membranes, they have been subject of several research projects. In various studies, Lerch, Loi-Brügger, Panglisch and colleagues demonstrated that surface water can be treated by coagulation with ceramic MF, while assuring high membrane flux and good permeate quality at the same time. Lerch et al. (2005a) investigated coagulation coupled with ceramic MF, similar to the one used in this work, for the direct treatment of river water (DOC  $\approx$  3mg/L, SUVA  $\approx$  2.8  $L \cdot (m \cdot mg \cdot C)^{-1}$ , turbidity between 1 and 3 NTU). Membrane flux was set to 80  $L/(m^2 \cdot h)$  and PACl was applied as coagulant. In the first period of operation a permeability decline of about  $-2.2 L/(m^2 \cdot h \cdot bar)/d$  was found and explained by the low retention of organic water contaminants by the coagulation / flocculation step. These components were thus able to adsorb onto the membrane surface. This particular fouling could not be cleaned extensively by the chosen cleaning procedure with backwashing and acid CEB only. This indicates the importance of efficient coagulation in order to reduce efficacy of major NOM foulant components, as described above. To enhance the operation performance, the coagulation procedure was optimized by enhancing coagulant distribution in the raw water and increasing the coagulant dosage to a range where co-precipitation or sweep coagulation of the organic water contaminants may



occur. After that, the membrane performance was much more stable in the first 2 weeks of operation. As a result, the permeability decline was highly improved from  $-2.2 \text{ L}/(\text{m}^2 \text{ h bar})/\text{d}$  to approximately  $0 \text{ L}/(\text{m}^2 \text{ h bar})/\text{d}$ . Loi-Brügger et al. (2006) investigated a 3<sup>rd</sup> generation ceramic MF module (Metawater Co., Ltd., Japan) as described in Chapter 4.5.4, for direct river water treatment with pre-coagulation. Research focus was on examination of flux, recovery, and DOC retention performance in order to determine optimum operating conditions, with special regards to economical aspects. During one year of pilot plant operation river water was treated with turbidity varying between 3 and 100 FNU. Membrane flux was increased stepwise from 80-300  $\text{L}/(\text{m}^2 \text{ h})$ , resulting in recoveries between 95.9 and 98.9%. However, the backwashing procedure had to be optimized at fluxes above 250  $\text{L}/(\text{m}^2 \text{ h})$  by increased frequencies of chemical enhanced backwashes (CEB), ranging from 0–8 per day. A DOC removal between 20-35% was achieved during the experimental period. The economic calculations showed very much comparable specific treatment cost for both polymeric and ceramic membrane systems. For large plants with capacities great than 1000  $\text{m}^3/\text{h}$ , specific treatment costs below 10 €/Ct are expectable for the combination of coagulation and membrane filtration. However, local conditions may have an important impact on economics. Panglisch et al. (2010) published results of a comprehensive long-term pilot plant study, comparing various membrane processes combined with conventional and advanced processes, in order to identify potential processes for the upgrade and extension of Luxembourg's largest drinking water plant. A nearby reservoir served as the water source. A variety of membrane processes was compared, such as UF, MF, RO and NF, coupled with a number of supportive treatment steps like oxidation, sorption and biological filtration. For the low-pressure filtration, UF and MF membranes from 4 manufacturers were compared, Inge, Pall and Zenon offering polymeric membranes as well as Metawater, who offered ceramic MF. So far only preliminary results of this pilot study have been published. However, to date the ceramic MF have shown a superior performance compared to the other 3 low-pressure membranes. With time the flux was increased stepwise from 80 to 100 and 120  $\text{L}/(\text{m}^2 \text{ h})$ , thereby increasing the recovery from 94.3 to 98.6%. The permeability at 20 °C of a process train which has had no technical failure so far remained very stable on the comparatively high level of 800  $\text{L}/(\text{m}^2 \text{ h bar})/\text{h}$ .

Konieczny et al. (2006) investigated the treatment of natural waters with a high content of organic compounds (TOC between 7 and 10 mg/L) by ceramic MF with pre-coagulation. Two different membranes were compared with nominal pore sizes of 0.1 and 0.2  $\mu\text{m}$ , as well as four different coagulants, both aluminium and iron based. Even though MF by itself removed a lot of the organic material, severe fouling was observed. However, with coagulation pre-treatment a high membrane flux could be maintained. No significant differences were reported between the four tested coagulants. Heijman and Bakker (2007) investigated the feasibility of ceramic membrane filtration (Metawater Co., Ltd., Japan), with pre-coagulation for the direct treatment of Twente

Canal water, The Netherlands. This water has been shown to have a fouling potential in various studies. It appeared that a flux of 150 L/(m<sup>2</sup> h) was feasible with this surface water and the use of 4 mg/l iron coagulant. The fluxes achieved by the ceramic membranes were two to three times higher compared to fluxes found with polymeric membranes treating the same surface water. In addition, the removal of MS2 bacteriophages was also monitored under the same conditions. The log removal varied from 4.7 to 6.2. In order to achieve a stable flux, the CEB procedure had to be optimised. It was found that hydrochloric acid and peroxide was the best performing combination. Further cost calculations showed that the ceramic membrane installations were competitive with installations with polymeric membranes. Ceramic membranes may require higher capital investment, but this can be counterbalanced by the higher stable fluxes. For an installation of 200 m<sup>3</sup>/h, a total water price was calculated to be 0.14 €/m<sup>3</sup> including the disposal of the wasted backwash water. Abrahamsson et al. (2007) reviewed the large scale application of similar ceramic membranes coupled with coagulation for the treatment of surface water with high TOC (7-8 mg/L) in the vicinity of Stockholm, Sweden. With ferric chloride dosages of 5 mg/L and at a pH below 7, around 40% of TOC was removed. A membrane flux of 100 L/(m<sup>2</sup> h) was maintained over several months. Simultaneously, the TMP increase was kept below 1 kPa/d. A further economic comparison with polymeric membranes showed that the ceramic membrane system was competitive in cost.

As of today, only one full-scale treatment plant using low-pressure membrane filtration with coagulation pre-treatment is in operation in Norway. The plant is dimensioned for a production of 12,000 m<sup>3</sup>/d at a temperature of 1°C and uses lake water as the water source. The raw water can be characterised by a colour of 28 to 32 mg Pt/L and temperature ranges 1.6 to 8°C throughout the year. Hollow fibre UF membranes from Norit X-Flow are applied, with a nominal pore size of 10 nm. Membrane flux is around 80 L/(m<sup>2</sup> h). A backwash is carried out every two hours, resulting in a recovery of greater than 90 %. Every 8<sup>th</sup> backwash is a CEB and performed with chlorine. The coagulation pH varies from 6.5 to 7.0 with PACl used as coagulant with a dosage of 1.8 mg Al/L. The treated water has a turbidity below 0.1 NTU and a colour below 4 mg Pt/L. The concentrated backwash water is discharged to the local sewer system. The operating costs of the plant were compared to NF, which is currently often used as the alternative system. Including energy consumption, chemical usage and operation and maintenance, coagulation with UF applied in Norway has been estimated to cost NOK 1.4 million per year, which is 20 % cheaper than direct NF treatment (Sandvik and Ødegaard, 2010). It was therefore concluded what coagulation UF can compete with conventional processes such as NF or direct filtration. One advantage mentioned was reduced need of floor space, making the process also interesting for the upgrade of older plants or capacity extension tasks.

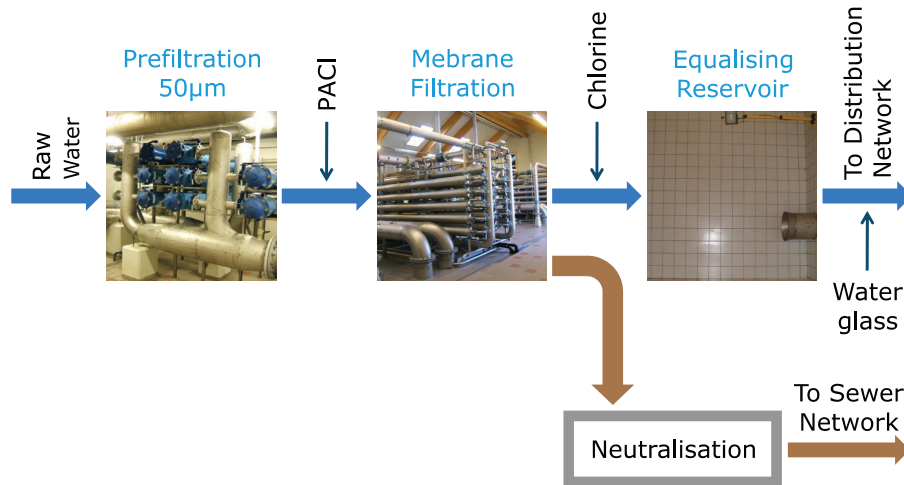

Figure 4.17: Schematic of the coagulation / UF surface water treatment plant in Lello, Levanger municipality, Norway, adapted from Sandvik and Ødegaard (2010)

As explained in this chapter, the interactions of coagulation pre-treatment with subsequent low-pressure filtration are manifold. In general, there is a clear trend that coagulation improves the permeate quality and further reduces membrane fouling. However, a successful achievement of such strongly depends on local conditions and the optimization of operation in each case. In spite of that, some general trends can be derived. Since different components of NOM, such as more hydrophilic polysaccharide- and protein-like NOM, have been identified as the most problematic foulants, these components should be rendered harmless by efficient coagulation in order to prevent adsorptive fouling. Furthermore, coagulation conditions strongly affect the permeability of a fouling layer that forms on the membrane as a function of the coagulation pre-treatment, where coagulation conditions near zero surface charge appear to be beneficial in order to maximise cake layer permeability. Furthermore, charge neutralisation conditions have been identified as suitable for producing a non-compressible cake with rather high permeability. At too low coagulant dosages, the very small particles may form which can cause either direct pore blockage on the membrane or a dense / non-porous cake layer to be formed. Table 4.10 summarises some advantages and disadvantages of low-pressure membrane filtration with coagulation pre-treatment.

Table 4.10: Advantages and disadvantages of low-pressure membrane filtration with coagulation pre-treatment

|   |  |
|---|--|
| ⊕ Improved permeate quality                     | ⊖ Increased sludge production and chemical costs due to coagulation, waste management and disposal needs |
| ⊕ Reduced membrane fouling                      |  |
| ⊕ Small footprint if inline coagulation is used | ⊖ Need for special handling of waste streams from CEB and periodic cleaning routines                     |
| ⊕ Low operating pressures, less energy demands  |  |
| ⊕ High fluxes achievable with ceramic MF        | ⊖ Improved monitoring and control of operating conditions  |
| ⊕ High recoveries and stable production         | ⊖ If coagulation not optimised, process performance may be poor  |
| ⊕ Cost efficient and competitive process        | ⊖ MF not a barrier against viruses   |

#### 4.6 Summary / comparison

As shown in this chapter, a variety of different treatment processes have been successfully used in the past for the treatment of Nordic surface waters. Newer, alternative processes are emerging and are expected to compete with the established technologies. All the introduced processes have their characteristic advantages and disadvantages and it would be therefore dubious to favour a certain process solution. No general recommendations can be given, since the reliability and competitiveness depends on many factors such as the dimensioning and process layout of a plant, the feed water quality, operating conditions, special local features etc. Nevertheless, Table 4.11 aims to compare the different treatment technologies introduced earlier with regard to some selected properties, such as delivered effluent quality, consumption of chemicals and energy, suitability for treatment of raw waters with NOM content and in perspective of treatment requirements and challenges for typical Nordic water sources.

Table 4.11: Comparison of different treatment processes with respect to treatment of Nordic waters\*

|   | Contact filtration  | Molde process   | Oxidation / bio-filtration                       | Ion exchange                          | Nano-filtration                                      | Coagulation - MF/UF  |
|---|---|---|--|---------------------------------------|--|--|
| General effluent quality                          | +++<br>If coagulation optimised                                       | +++<br>If coagulation optimised                                       | ++<br>Slow bio-degradable fraction not removed   | ++<br>Turbidity breakthrough          | +++<br>If membranes are intact                       | +++<br>If coagulation is optimised                           |
| Suitability for high NOM concentrations           | ++<br>Increased backwash frequency                                    | ++<br>Increased backwash frequency                                    | +<br>Poor removal                                | +<br>Quick load, early breakthroughs  | ++<br>Higher membrane fouling                        | ++<br>Increased backwash frequency                           |
| Adaption to seasonal changes in raw water quality | +++<br>Monitoring of feed quality and coagulation adjustments crucial | +++<br>Monitoring of feed quality and coagulation adjustments crucial | ++<br>Only O <sub>2</sub> dosage can be adjusted | +<br>Not flexible, fast breakthrough  | ++<br>Severe fouling if high turbidity or silt loads | +++<br>If feed quality is monitored and coagulation adjusted |
| Consumption of chemicals                          | ++<br>Coagulant   | ++<br>Coagulant and consumed marble                                   | +++<br>No special requirements                   | +<br>Elution and resin regeneration   | +<br>Daily membrane cleaning                         | ++<br>Coagulant and CEB                                      |
| Consumption of energy                             | +++<br>Maybe feed water pumping against gravity, filter backwash      | +++<br>Maybe feed water pumping against gravity, filter backwash      | ++<br>Ozone generation on site                   | +++<br>Pumping of different solutions | +<br>High pressure and cross flow, frequent cleaning | ++<br>Feed water pumping, no cross flow, low pressures       |
| Sludge production                                 | +<br>Coagulation sludge   | +<br>Coagulation sludge   | +++<br>No significant sludge production          | ++<br>Regenerate must be treated      | ++<br>Cleaning solutions must be handled             | +<br>Coagulation sludge                                      |
| Simplicity of operation                           | ++<br>Experienced operator needed                                     | ++<br>Experienced operator needed                                     | ++<br>Experienced operator needed                | ++<br>Experienced operator needed     | +++<br>Fully automated                               | ++<br>Automated but coagulation needs operator experience    |
| Hygienic barrier potential                        | +++<br>Only if coagulation is optimised                               | +++<br>Only if coagulation is optimised                               | ++<br>Inefficient against Cryptosporidium        | +<br>No hygienic barrier              | +++<br>If membranes are intact                       | +++<br>MF against viruses only with coagulation              |
| Footprint   | ++<br>With inline coagulation   | ++<br>With inline coagulation   | +<br>Reaction space needed                       | +<br>Numerous ion exchangers          | ++<br>Can be stacked, but low fluxes                 | +++<br>At high fluxes with inline coagulation                |

\*Rating system: +++ good, ++ reasonable, + poor



## Summary of experimental configuration and methods

### 5.1 Investigated process configurations

In this work the focus has been on the investigation of coagulation/flocculation pre-treatment on various operating and quality parameters, particularly the membrane filtration performance. The configuration of the membrane modules and filtration unit, however, was not altered in the study. Therefore, modifications in the pre-treatment setup involved the examination of different modes and process units for coagulation, such as conventional tank coagulation compared to inline coagulation. These different modes of coagulation have further been subject to several attempts of simplification. A full overview and illustration of the investigated pre-treatment configurations is given in Figure 5.1.

The initial configuration consisted of a complete conventional coagulation/flocculation setup including tanks for rapid and slow mixing (Figure 5.1 a). The hydraulic retention time (HRT) of the water in this setup was in the range of several minutes, usually 20. Results obtained with this pilot plant configuration are summarised in Publication 1 (Chapter 6.1). Despite the fact that the flocs created in the pre-treatment stage were destroyed in the membrane feeding pump, sufficient process performance was achieved. It was hence concluded that the process most likely can be simplified while still fulfilling the pre-treatment objectives sufficiently. Thus, an alternative mode of operation was first investigated by eliminating the slow mixing step (Figure 5.1 b), reducing the total HRT in the pre-treatment to 5-7 minutes. As a next step all the mixing tanks were eliminated and substituted by a system where acid and coagulant were dosed directly preceding the membrane feeding pump, using the pump as a rapid mixer, followed by pipe flocculation (Figure 5.1 c). Results predominantly based on this setup are published in the Publications 2 and 3, in Chapters 6.2 and 6.3 respectively.

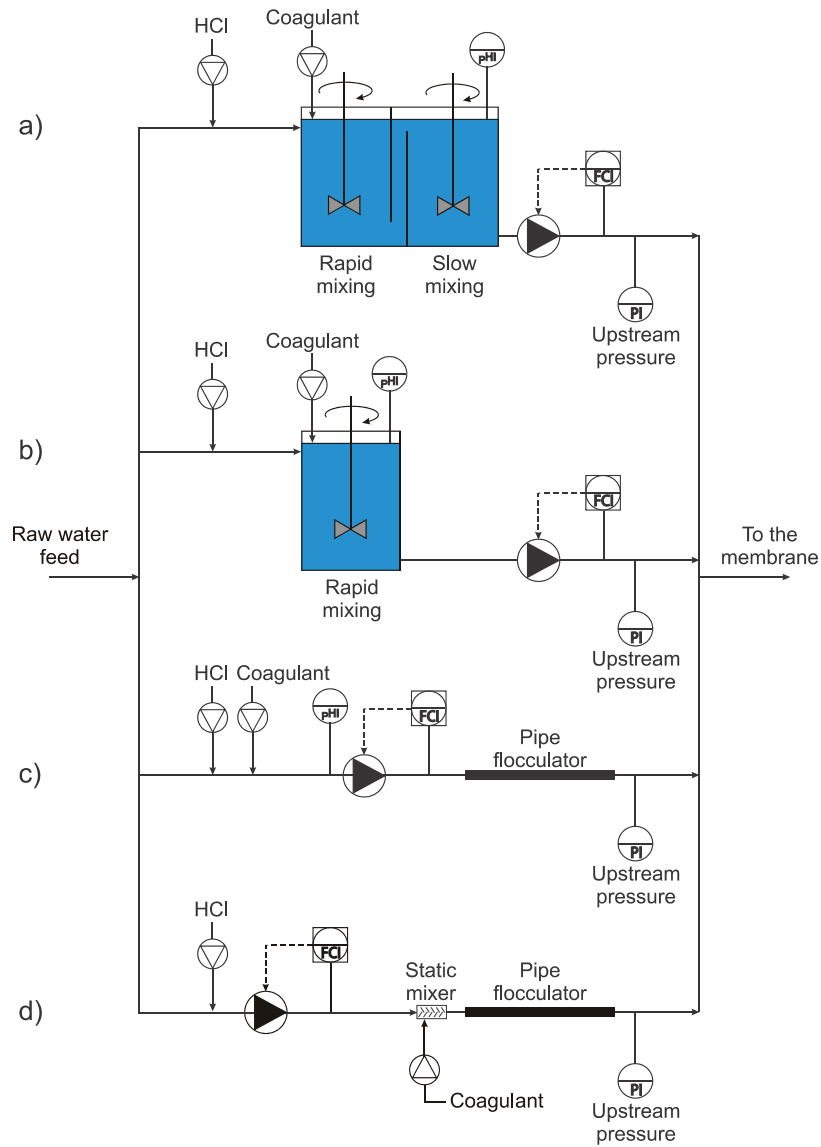

Figure 5.1: Schematic of all pre-treatment configurations investigated in this study: a) Conventional pre-treatment with rapid and slow mixing; b) Simplified conventional pre-treatment containing only a rapid mixing step; c) Inline coagulation with pipe flocculation, utilizing the membrane feeding pump as rapid mixer; d) Inline coagulation with static mixer and pipe flocculation.



The inline configuration was further modified by introducing a static mixer, having the advantage of a more controlled mixing environment compared to using the membrane feeding pump as a mixer (Figure 5.1 d). With this setup extensive experiments have been carried out in order to identify the minimum of flocculation necessary as a pre-treatment for ceramic microfiltration, when treating Nordic waters. The results of these investigations are presented in Publication 4 in Chapter 6.4.

## 5.2 Ceramic membrane properties

The ceramic microfiltration membranes used in this work are produced by Metawater Co., Ltd., Japan. According to the manufacturer specifications, the nominal pore size is 100 nm. The membrane modules used in the pilot plant are 1 m long and have a diameter of 3 cm. Each module has 55 channels with a diameter of 2.5 mm. The membrane area of such a module is 0.43 m<sup>2</sup>. A side view of the membrane and the pilot plant setup are shown in Figure 5.2. The pilot plant was equipped with three parallel independent process trains, each containing one membrane module.

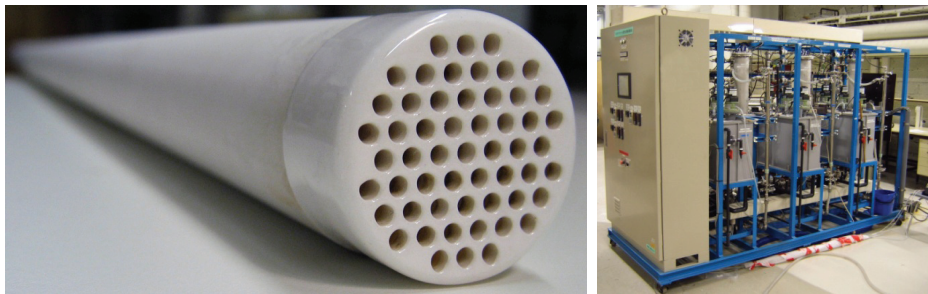

Figure 5.2: Ceramic microfiltration module and filtration pilot plant

The membrane is made of aluminium based ceramic and can be characterized as asymmetric with two macro-porous support layers with a thin active layer on top, as illustrated in Figure 5.3 (left). Figure 5.3 (right) shows a SEM picture of the membrane surface. The membrane can be considered as highly hydrophilic by the rather high pure water flux of the membrane, which was measured to be  $42.9 \pm 3.8$  m<sup>3</sup>/m<sup>2</sup>/d at a pressure of 1 bar and 25°C. The applied membrane modules belong to the first generation of ceramic microfiltration membranes developed by Metawater Co., Ltd. Recently a 3<sup>rd</sup> generation was developed. These modules are 1.50 m long, have a diameter of 0.18 m and comprise a membrane area of 25 m<sup>2</sup> distributed into 2000 channels.

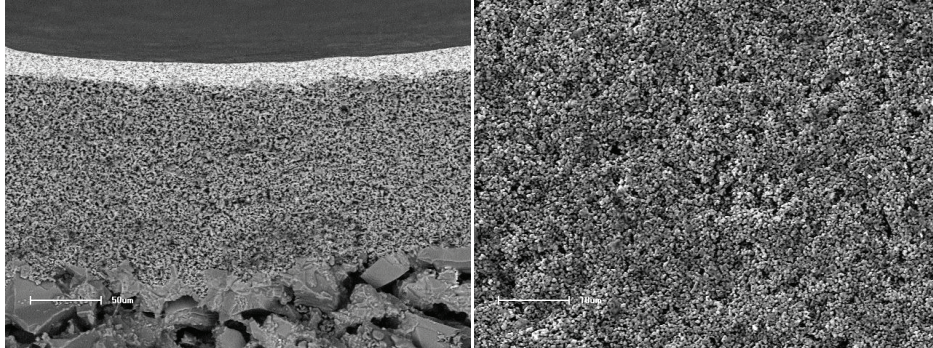

Figure 5.3: SEM pictures of the ceramic membrane used in this study, cross section (left) and membrane surface (right)

The membranes were operated in dead-end, inside out configuration. Once pressure was applied to the module, raw water was forced into the channels, through the membrane and into the porous support. Permeate left the membrane along the porous outer surface of the module as schematically shown in Figure 5.4 a). After 2 to 6 hours of operation a backwash was carried out. A normal backwash procedure was performed with permeate. If necessary, an enhanced backwash could be applied where a low dose of disinfectant/oxidant is added to the backwash water to remove foulants and restore membrane permeability. A backwash consisted of two stages. First, backwash water was forced into the module in opposite filtration flow direction, with pressures up to 5 bar and for a maximum period of 20 s (Figure 5.4 b). As a consequence, fouling attached to the membrane was detached from the surface. In the second stage, an air flush was performed, discharging the exfoliated material out of the module (Figure 5.4 c).

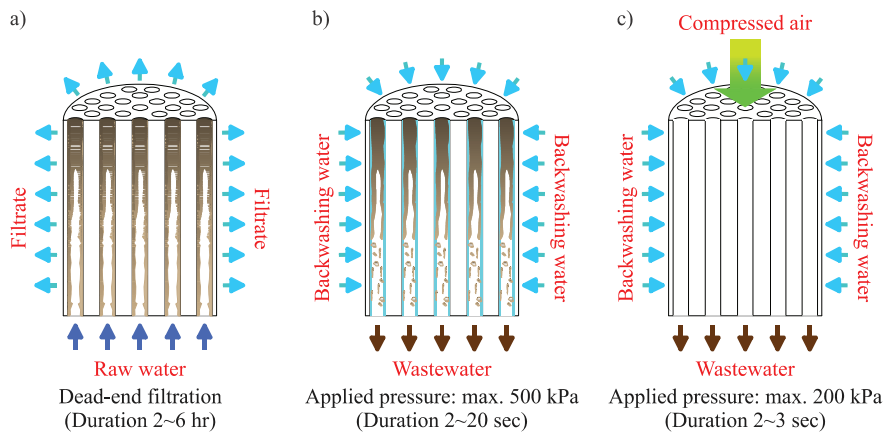

Figure 5.4: Different stages of an operating cycle: a) filtration, b) backwash, c) air flush

### 5.3 Raw water characterization

In order to be independent from seasonal variations and to have stable experimental conditions, an analogue raw water was used in this study. The alkaline regenerate solution, obtained from a nearby ion exchange water treatment plant treating surface water, was used as the basis for the analogue raw water. The regenerate was mixed with the Trondheim tap water, diluted 500 to 1000 times to achieve the desired DOC and colour content of the feed water. Due to the high conductivity of the regenerate, the conductivity of the created raw water was 455  $\mu\text{S}/\text{cm}$ , around 3.5 times higher than in the tap water. The alkalinity of the raw water was around 1 mmol/L. This procedure has been successfully used in the past in several studies (Eikebrokk, 1999; Saltnes et al., 2002; Machenbach, 2003; Kvinnesland and Ødegaard, 2004; Leiknes et al., 2004). Composition of the regenerate was compared with different batches and stability over time was monitored by Liquid Chromatography coupled with organic carbon detection (LC-OCD), and no substantial changes have been found.

The organic matter concentrate used in this study can be characterized as highly hydrophobic and humic acid like. This is supported by the Fluorescence Excitation-Emission-Matrix (F-EEM) shown in Publication 1, Chapter 6.1. The organic matter can be further characterized by a relatively high Specific UV-absorption (SUVA) of 4.5  $\text{L}\cdot(\text{m}\cdot\text{mg C})^{-1}$ , which indicates a high aromatic carbon content (Croue et al. 1999). Analysis of the raw water by LC-OCD revealed that most of the carbon content (67.5%) could be attributed to humic substances. Another 30% is equally shared among hydrophobic organic carbon (HOC), building blocks and low molecular weight acids. All results are shown in Figure 5.5. The analogue raw water was further compared with natural lake water from the vicinity of Trondheim. It could be seen that the waters had a similar characteristics. However, the lake water contained less humic substances (57.8%). The SUVA of 4.3 is in the same range as the raw water used in this study.

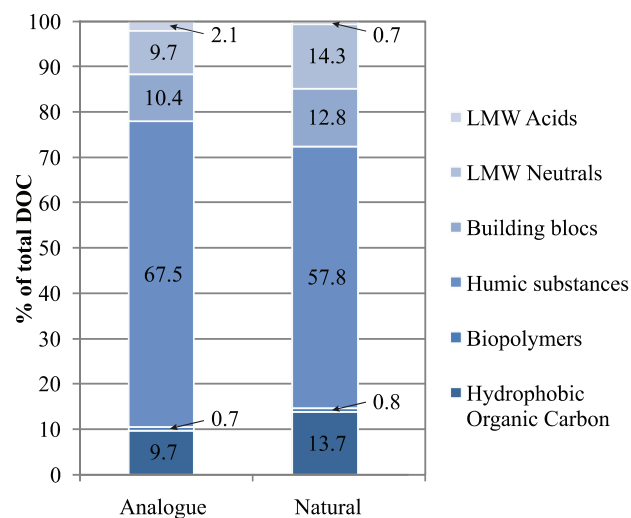

Figure 5.5: Organic carbon fractions in the analogue raw water used in this study, compared to natural lake water.

As shown in Figure 5.6, the analogue raw water used in this study has the same footprint as the natural lake water as well as the tap water used for dilution of the regenerate.

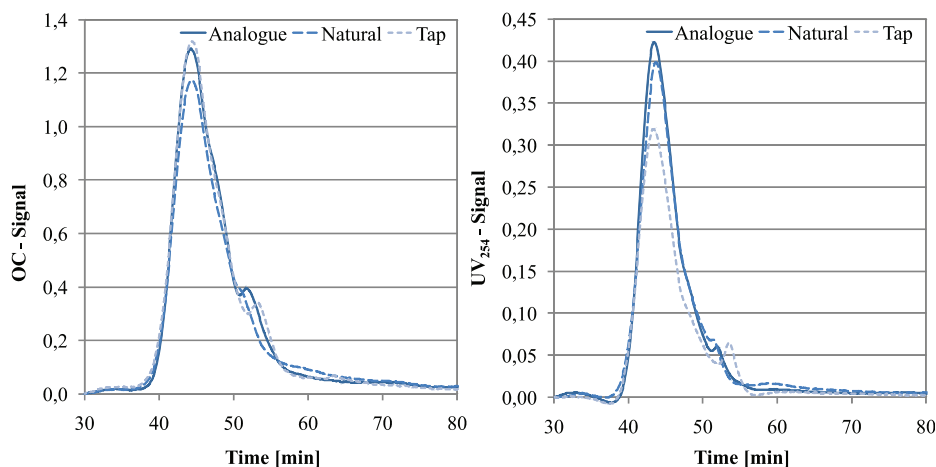

Figure 5.6: LC-OCD chromatograms of the analogue raw water, natural lake water and the Trondheim tap water (normalised to a DOC of 1 mg/L).

DOC fractions obtained by rapid resin fractionation according to the method presented by Chow et al. (2004), were further analysed by LC-OCD. NOM was divided into 4 fractions: very hydrophobic acids (VHA), slightly hydrophobic acids (SHA), hydrophilic charged (CHA) and a hydrophilic neutral (NEU). Results of the analyses are

shown in Figure 5.7. VHA and SHA predominated, containing the typical humic substances like humic and fulvic acids. The CHA fraction contained the smaller but charged molecules, such as proteins. The NEU fraction typically consisted of low molecular acids, polysaccharides etc.

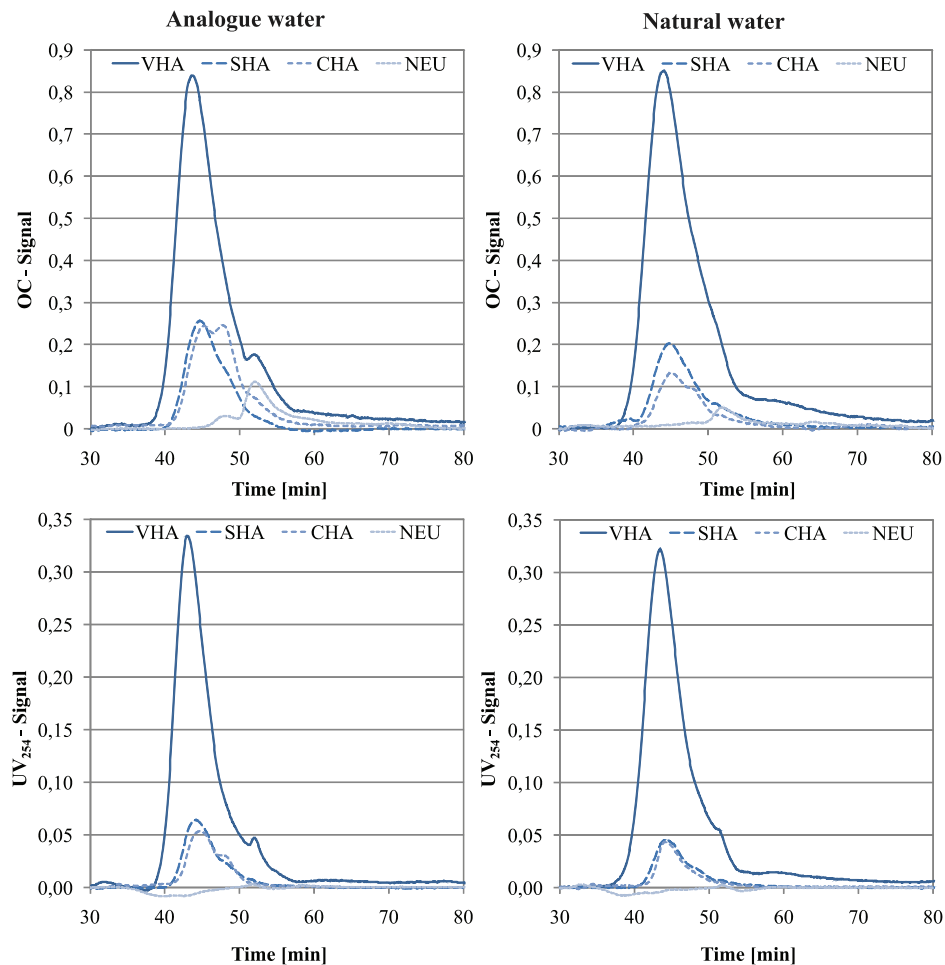

Figure 5.7: LC-OCD chromatograms of different DOC fractions obtained from the analogue raw water (left column) and natural lake water (right column) showing the organic carbon signal (top row) and UV254 signal (bottom row).

The chromatograms show that the fractions in both types of water have a rather similar composition, even though the fraction distribution itself varies a little between the waters. The VHA fraction clearly dominates both waters and contained most of the hydrophobic humic substances. As can be seen in the organic carbon chromatograms, it

contained almost all the high molecular substances, which show high UV absorption and are assumed to have high aromaticity. However, this fraction further contained many of low molecular DOC as well, like building blocks and low molecular weight neutrals, which show only low UV absorption. It should be noted that the size distribution of the DOC was marginally wider in the natural lake water. Furthermore, the analogue water had a higher CHA content. Both waters contained a significant percentage of neutrals (NEU). However, this fraction did not show any UV-absorption at all. Generally it can be stated that the differences in NOM composition of the two compared waters were rather small. Since both waters were dominated by the VHA fraction and have high SUVA values, it was assumed that they were easily treatable by coagulation, as explained in Chapter 3.4. Furthermore, the results of these analyses confirm that the analogue water used in this study is a good representation of natural raw water sources typically found in Norway.

#### 5.4 In-situ floc characterisation

There are numerous methods for the investigation of floc properties, i.e. size measurements by particle counters, microscopic analysis coupled with image capturing, laser based sizing, settling experiments and derivation of floc density, correlative microscopy with confocal laser scanning microscopy (CLSM) or transmission electron microscopy (TEM) and many more. However, by a lot of these techniques flocs can be analysed only *ex-situ*. Often floc properties are irreversibly altered by sampling or sample transportation. Furthermore, flocs created by coagulation will most likely change after sampling, since they are part of a dynamic system of chemical reactions and physical interactions. Therefore, such measurements will most likely not truly represent experimental conditions.

In this study, floc growth was monitored with the Photometric Dispersion Analyser 2000 (PDA 2000, Rank Brothers LTD, Cambridge, UK). As thoroughly described by Gregory and Nelson (1986) the PDA 2000 illuminates the sample suspension which is flowing through a transparent tube by a narrow light beam. Since the suspension is flowing, the number of particles in the light beam is changing continuously. These variations cause fluctuations in the intensity of transmitted light which can be monitored by a sensitive photodiode. The output of this diode is then converted to a voltage signal proportional to the intensity. The output voltage has a large *dc* component corresponding to the average transmitted light intensity, which is related to the turbidity of the suspension, and a much smaller fluctuating (*ac*) component due to the random variations in particle number. The *ac* component is separated from the *dc* component and amplified (Figure 5.8 a) and b). Then, the root mean square (*rms*) value of the fluctuating (*ac*) signal is derived, which has been shown to be a sensitive indicator of the state of aggregation of the suspension (Gregory and Nelson, 1986). The frequency



of the fluctuating signal depends on the flow rate of the suspension and the width of the light beam. When the flow stops, the fluctuations cease.

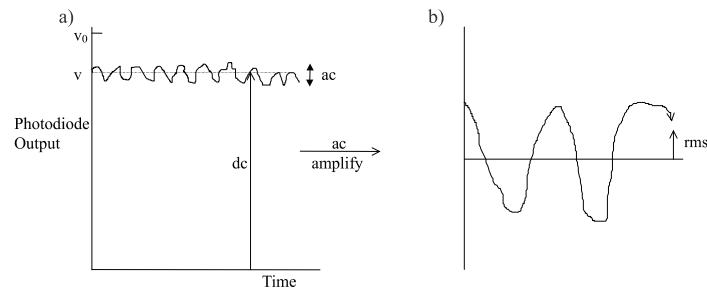

Figure 5.8: Processing of the photodiode signal: a) decomposition of the signal, b) amplified ac signal and *rms* derivation (Gregory and Nelson, 1986)

The *rms* value of the fluctuating signal depends on the concentration and size of the suspended particles. For a uniform suspension, it is possible to estimate the particle number concentration. In order to do that the turbidity of the sample suspension, which can be calculated from the *dc* value, has to be known. A more valuable feature of the *rms* value is that it shows a marked increase as particles aggregate. Conversely, disaggregation causes a substantial decrease in the *rms* value. Corresponding changes in the *dc* value and thus the turbidity are much less significant. However, in most practical cases quantitative interpretation of the *rms* reading in terms of particle or aggregate size distribution is not possible. Nevertheless, the reading gives a very useful empirical indication of the state of aggregation. For a given suspension, changes in the state of aggregation of particles give large changes in the *rms* and the ratio (*rms/dc*). Flocculation can cause an increase by a factor of five or more in these readings before any visible signs of change are apparent. During this increase, the *dc* output usually shows a change of only a few percent. The ratio (*rms/dc*), in this study called flocculation index, provides a sensitive index of particle aggregation. The detection limit is in the range of particle sizes between 0.5 and 1.0  $\mu\text{m}$ , depending on the suspension (Gregory and Nelson, 1986; Gregory and Dupont, 2001). The PDA 2000 is shown in Figure 5.9.

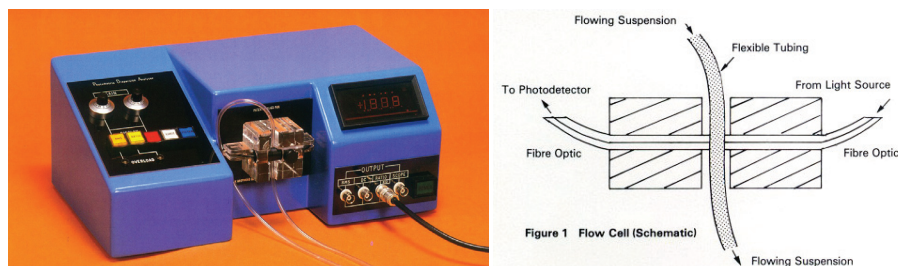

Figure 5.9: The PDA 2000 and a schematic of the flow cell

## 5.5 Online DOC and colour measurements

In order to get as much information from experiments as possible, a reliable online monitoring system is crucial. Therefore, the pilot plant was equipped with a spectrometric probe (spectro::lyser™, Scan Messtechnik GmbH, Vienna, Austria), measuring continuously DOC, colour and turbidity. By using the probe, sample analysis was independent from laborious and time consuming classical techniques. However, these were used for calibrating the probe. The spectro::lyser™ had a path length of 10 cm, measuring in a wavelength range from 220 to 720 nm with a resolution of 2.5 nm, making the measurements very sensitive. The probe was not mounted submerged, but with a bypass flow cell.

The spectro::lyser™ is equipped with calibration algorithms that allow a turbidity compensation of the spectrum. The compensation allows the measurement of solution parameters without filtration, even if turbidity is present. The wavelengths used for the determination of the water parameters have been selected using principal component analysis and partial least square regression (PLS) on hundreds of data sets containing UV/Vis spectra and reference values of the water parameters (van den Broeke et al., 2009). The wave length range of the probe, together with wave length areas where different water parameters are derived from is schematically shown in Figure 5.10. As already mentioned, the factory calibration was refined locally since too low values for DOC were obtained. Colour was measured either directly as VIS<sub>436</sub> or was calculated as mg Pt per litre from the VIS<sub>410</sub> value.

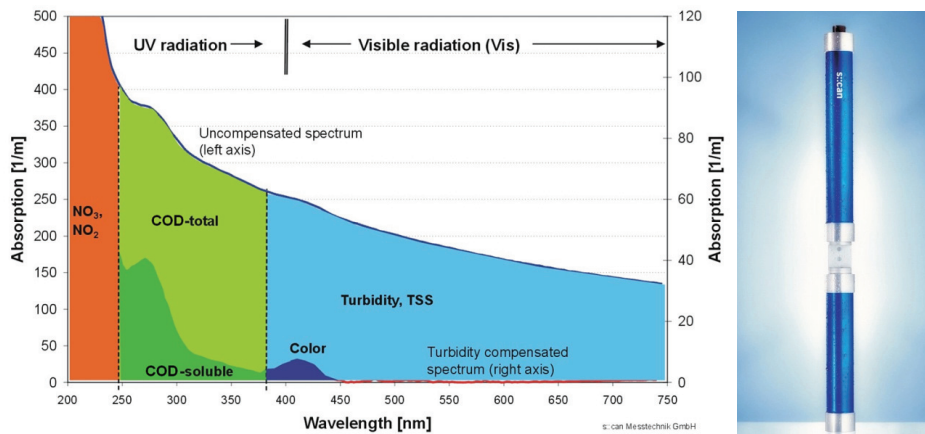

Figure 5.10: UV/Vis spectrum and examples of parameters derived out of this spectrum together with their characteristic absorbance profiles, S::CAN Spectrolyser (van den Broeke et al., 2009)



## 5.6 PLS-regression

Partial Least Squares (PLS) regression was used in order to identify the influential operating parameters and their effect on the process performance. Such a multivariate statistical tool may be helpful for analysing complex correlations as seen with coagulation and flocculation coupled with membrane filtration, where an overall quantitative comparison of operating conditions and their influence on the process is very complex.

PLS regression generalizes and combines features from principal component analysis and multiple regression. This method is particularly useful when predicting a set of dependent variables from a large set of independent variables. The method models both the X- and Y-matrices simultaneously to find the latent (or hidden) variables in X that will best predict the latent variables in Y. These PLS components are comparable with principal components, but are named as factors. A conceptual illustration of PLS regression is shown Figure 5.11.

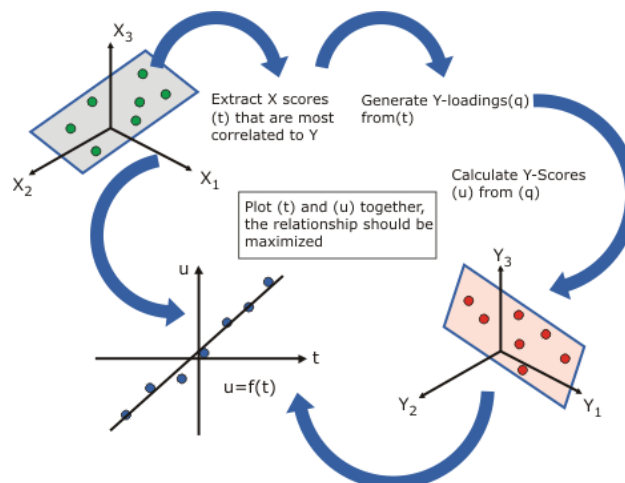

Figure 5.11: Conceptual illustration of PLS regression (courtesy of CAMO Software Inc.)

PLS regression linearly transforms data from a large number of original predictors to a new variable space defined by a small number of orthogonal factors, called PLS components or latent vectors. These PLS components are mutually independent linear combinations of the original predictors. By performing a simultaneous decomposition of X and Y, the PLS algorithm determines these components iteratively in such a way that the first PLS component explains most of the covariance between X and Y, the second component explains the maximum share of the residual covariance, and so on. The

regression may be carried out with one or more Y variables, meaning that multiple Y responses can be used during regression modelling. Regressions are accompanied by a validation procedure to find the optimal number of PLS components and test models for robustness (Esbensen, 2002).

Before the analysis all data were centred and weighted. By centring the average from each variable is subtracted. This procedure is called mean-centring and ensures that all results will be interpretable in terms of the variation around the mean. Weighting is important when variables have largely different value ranges. This is commonly the case if different types of variables are compared with each other. All variables are multiplied with the reciprocal of their respective standard deviations  $1/SD_{dev}$ . As a consequence, each variable has the same variance and thus the same chance to influence the estimation of the PLS components. Only the predictor variables were weighted, not the response variables.

A full linear first-order model without interactions and non-linear terms has the general form:

$$y = \beta_0 + \beta_1 x_1 + \beta_2 x_2 + \dots + \beta_n x_n + \epsilon \quad (4.5)$$

Where:  $y$  is the response variable  
 $x$  the predictor variables  
 $\beta$  the real regression coefficients  
 $\epsilon$  the residual error.

The real regression factor can be calculated by multiplying the weighted regression factor with its weight. The weighted regression coefficients can be used to compare the influence of predictors against each other. They show how each variable is weighted when predicting a particular Y response. Regression coefficients are a characteristic of all regression methods and may provide interpretive insight into the quality of a model. When different variable types exist, regression coefficients show the relative importance of the variables and their interactions can also be displayed. The quality of a regression model can be estimated by the residual  $y$ -variance, which is a measure for how much of the variation in the data cannot be explained by the model. It is the amount of variance which remains until the variance explained by the model is removed from consideration. The explained  $y$ -variance is the complementary value to the residual  $y$ -variance. The sum of both variance types equals 1 or 100%. The regression models were validated by full cross-validation. For all calculations the algorithm "Orthogonal Scores PLS" was used which is sometimes also called classical PLS. It is thoroughly described in Martens and Næs (1989).

---

For the modelling the software package “The Uncrambler X” was used (version 10.0.1, CAMO Software Inc., Woodbridge, NJ, USA). In addition to the results presented in Chapter 7.4, additional information and supplemental data regarding the regression analysis can be found in Appendix A.2.



## Published results

### 6.1 Publication 1

The following article, written by Thomas Meyn and Tor Ove Leiknes, has the title “Comparison of optional process configurations and operating conditions for ceramic membrane MF coupled with coagulation/flocculation pre-treatment for the removal of NOM in drinking water production” and was published 2010 in the Journal of Water Supply: Research and Technology – Aqua, Volume 59, Issue 2-3. Even though it was published in early 2010, it presents results of an earlier experimental series.

Focus was on the investigation of the influence of pH value, coagulant type and dose on the process performance, measured as DOC and colour removal, residual metal concentration as well as reversible and irreversible fouling, using a conventional tank coagulation pre-treatment. Initial results assessing a simplified inline coagulation setup are also part of its content.



## **Comparison of optional process configurations and operating conditions for ceramic membrane MF coupled with coagulation/flocculation pre-treatment for the removal of NOM in drinking water production**

**Thomas Mevn<sup>1</sup> and TorOve Leiknes<sup>2</sup>**

Norwegian University of Science and Technology, Department of Hydraulic and Environmental Engineering, S.P. Andersensvei 5, N-7491 Trondheim, Norway

<sup>1</sup> Tel.: +47 7355 0375, E-mail: [thomas.meyn@ntnu.no](mailto:thomas.meyn@ntnu.no)

<sup>2</sup> Tel.: +47 7359 4758, E-mail: [torove.leiknes@ntnu.no](mailto:torove.leiknes@ntnu.no)

**Abstract** Increase of Natural organic matter (NOM) in natural water sources, partly caused by progressing climate change issues, is a growing concern for drinking water production. In recent years, membrane technology like Reverse Osmosis (RO) or Nanofiltration (NF) has been successfully applied as robust solution for NOM removal to produce potable water. However, coagulation/flocculation pre-treatment, combined with Microfiltration (MF) ceramic membrane filtration is nowadays seen as an alternative less energy consuming membrane process for NOM removal. In this study different coagulants have been used under varying coagulation/flocculation conditions to investigate the respective impact on membrane filtration performance. Three alternative coagulation/flocculation configurations were compared. It is shown, that NOM was efficiently removed independently on the chosen configuration or coagulant type. Similar and low membrane fouling rates were observed for all tests. Residual metal concentration was found to be the limiting permeate quality parameter which limits the options of operating conditions. Further on, the compact inline pipe flocculator configuration has the potential of designing more compact full scale units, using less space compared to conventional sand filtration units or even membrane filtration plants using classical tank coagulation/flocculation configurations.

**Keywords** Ceramic membranes, Coagulation, Drinking water, Flocculation, Microfiltration, Natural organic matter

### **Introduction**

Surface water is a common drinking water source. Approximately 90 % of the population in Norway consumes drinking water which originates from surface water (80 % - lakes, 10 % - rivers). In many cases these waters are typically characterised by a high content of Natural Organic Matter (NOM), resulting in high colour, very low turbidity, low alkalinity and low hardness, due to the natural conditions (Ratnaweera et al., 1999). Table 1 gives an overview of typical raw water properties and the demands of the drinking water guidelines as published by The Norwegian Institute of Public Health.

Colour is expressed in Hazen units as Pt/L units and organic matter as TOC or COD in mg/l C or mg/l O respectively.

Table 1: Typical raw water quality and drinking water guidelines in Norway (Nasjonalt folkehelseinstitutt, 2004)

| Raw water quality             | Drinking water standards (limiting values) | Recommendations from authorities            |
|-------------------------------|--|---|
| High colour (30 - 80 mg Pt/L) | 20 mg Pt/L                                 | 5 mg Pt/L ( $VIS_{436} \approx 0.3m^{-1}$ ) |
| High TOC (3 - 8 mg/L)         | 5 mg/L                                     | 3 mg/L                                      |
| High COD (4 - 8 mg/L)         | 5 mg/L                                     | 3 mg/L                                      |
| Low turbidity (< 1 NTU)       | 1 NTU at WTP<br>4 NTU at consumers         | 0.2 NTU                                     |
| Low alkalinity (< 0.5 meq/L)  | No limiting value                          | 0.6 - 1 meq/L                               |
| Low hardness (< 5 mg Ca/L)    | No limiting value                          | 15 - 25 mg/L Ca                             |
| Aluminium & Iron              | 200 µg/L for both                          | 150 µg/L for both                           |

Although the main part of NOM is not harmful, some fractions like algogenic matter can cause colour, taste and odour problems or are even toxic like the algae toxin microcystin. Special fractions of NOM in the drinking water can potentially lead to bacterial regrowth in the distribution system. Removal of NOM also reduces the load of following treatment steps and facilitates elimination of important trace compounds such as pesticides found in the NOM. Furthermore, these substances increase the necessary amount of disinfectants and are recognized as precursors for disinfection by-product formation, such as THM's which can be carcinogenic. The Norwegian Institute of Public Health has subsequently provided limiting values and recommendations in the national drinking water guidelines. The removal of NOM is therefore one of the major concerns and makes an advanced drinking water treatment necessary.

There is a growing concern on the increase of NOM in natural water sources, where recent studies have shown that the concentration of NOM in surface water might increase during the next decades partly caused by progressing climate change issues. Due to increased precipitation in parts of Scandinavia during the last 30 years the water pathways in many catchments have changed, leading to an increased leaching of organic compounds from the upper forest floor to the lakes. In some areas a concentration increase of up to 50 % of colour and DOC between 1983 and 2000/2001 has been reported (Forsberg, 1992; Hongve et al., 2004).

Direct filtration of NOM by NF membranes has been successfully used for full scale drinking water treatment in Norway. (Ødegaard et al., 1999; Ødegaard et al., 2000). Polymeric porous membranes, eventually coupled with an appropriate pre-treatment option for fouling minimization, such as coagulation, is an alternative process scheme



that can be efficiently used for the removal of NOM and for the treatment of surface water (Cho et al., 2006; Kim et al., 2001; Lahoussine-Turcaud et al., 1990; Machenbach, 2005; Peuchot and Ben-Aim, 1992). Membrane filtration processes are commonly viewed as an energy intensive treatment scheme where more energy efficient, low pressure membrane options may be preferred alternatives.

In this respect, ceramic microfiltration membranes are an interesting alternative to polymeric membranes. In addition, due to their physical properties, mechanical stability and resistance to chemicals, ceramic membranes have shown to be superior compared to organic membranes, particularly with respect to cleaning alternatives (Lee and Cho, 2004; Weber et al., 2003). This should be considered especially since NOM was identified as a major foulant in surface water treatment (Kimura et al., 2008; Yamamura et al., 2007), causing irreversible fouling which cannot be cancelled by backwashing, but only by extended chemical cleaning.

Ceramic membranes allow an easy and complete recovery of membrane performance through a whole variety of cleaning procedures, using all kinds of chemicals if necessary and show a potential for replacing polymeric membranes in drinking water treatment (Lee and Cho, 2004; Lerch et al., 2005; Weber et al., 2003). Higher investment costs of ceramic compared to organic membranes can be diminished by operating ceramic membranes with higher fluxes and by considering higher lifetimes. Ceramic membranes are commonly manufactured as multichannel units which promotes alternative membrane module designs and operating conditions.

This study has investigated the use of coagulation/flocculation, combined with MF ceramic membrane filtration as an alternative membrane process for the removal of NOM to produce potable water. Different coagulants have been used under varying coagulation/flocculation conditions to investigate the impact on the membrane filtration performance. Two alternative process configurations for the pre-treatment stage were compared.

### **Methods**

*Raw water.* The raw water used in this study was prepared using a NOM concentrate from a full scale ion exchange treatment plant, which was mixed with tap water to make up an analogue water with a turbidity of around 1 NTU, a colour of  $50 \pm 1.13$  mg/L Pt at pH 7 (corresponding to an absorbance of  $1.97 \text{ m}^{-1}$  at a wavelength of 436 nm), a  $\text{UV}_{254}$ -absorbance of  $23.8 \pm 0.8 \text{ m}^{-1}$  and a DOC concentration of  $5.2 \pm 0.3$  mg/L. Analogue feed water ensures that the same experimental conditions apply for all experiments conducted. Previous studies have shown that this method can be successfully used and simulates real conditions quite well (Leiknes et al., 2005; Leiknes et al., 2004).

The NOM concentrate used in this study can be characterized as highly hydrophobic and humic acid like. This can be derived from the relatively high SUVA of 4.5 and is supported by the Fluorescence Excitation Emission Matrix (F-EEM) shown in Figure 1a). The NOM concentrate diluted in distilled water shows a very distinct peak at an excitation of 305 nm and an emission of 430 nm. This falls in the humic acid like region, previously identified and classified in literature (Chen et al., 2003). The FTIR spectrum shown in Figure 1b) is dominated by two broad peak regions. One lies between 2900 to 3650  $\text{cm}^{-1}$  and includes bands of OH stretching vibrations (3200 - 3550  $\text{cm}^{-1}$ ) and C-H stretching vibrations (3000 - 3340  $\text{cm}^{-1}$ ). The second active region is located between 1300 to 1800  $\text{cm}^{-1}$  and contains signals of conjugated C=O stretching (1590 - 1750  $\text{cm}^{-1}$ ), C=C stretching (1585 - 1625  $\text{cm}^{-1}$ ) and CH bending in methyl and ethyl groups (1355 - 1465  $\text{cm}^{-1}$ ). Since no very sharp and distinct peaks are visible it can be assumed that the used NOM in this study contains a variety of different organic compounds with varying functional groups.

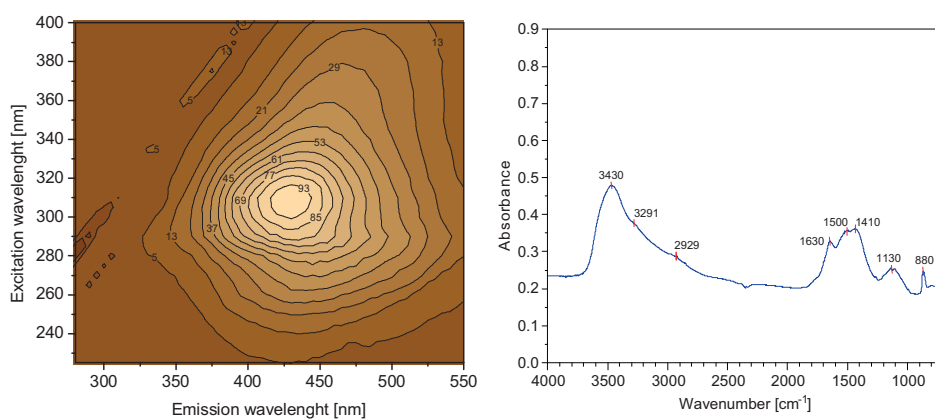

a) F-EEM

b) FT-IR spectrum

Figure 1: NOM characterization

*Pilot plant configuration.* Experiments were done with a membrane filtration pilot plant using a classical coagulation/flocculation pre-treatment configuration, shown in Figure 2a). Prior to the membrane filtration unit, a two tank coagulation/flocculation setup with a rapid mixing followed by a slow mixing step was used. After that, the coagulated water is filtered by the membrane unit. The pilot plant was equipped with 3 identical and independent process trains. A second option using an inline pipe flocculator was also investigated as an alternative to the classical configuration, shown in Figure 2b).

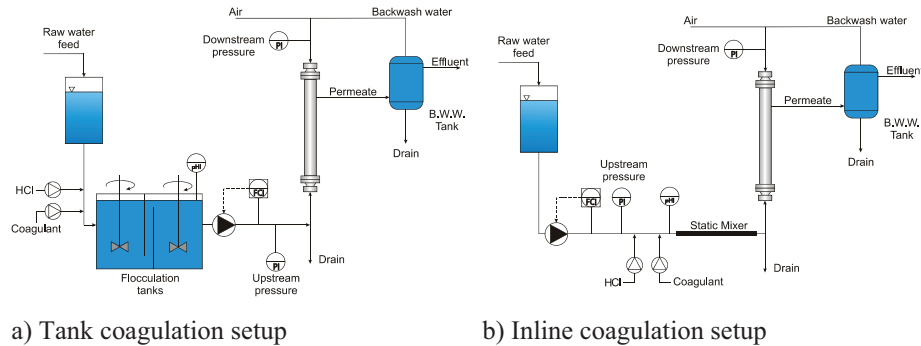

Figure 2: Flow diagram of the different membrane filtration plant configurations

In this study multi-channel ceramic membranes, operated in dead-end, inside-out mode with a nominal pore size of  $0.1 \mu\text{m}$  were investigated. Each membrane module had 55 channels, was 1 m long and had an effective area of  $0.43 \text{ m}^2$ . The feed water was pumped in up-flow direction. The plant was operated in constant flux mode, maintaining a flux of  $143 \text{ L}\cdot\text{m}^{-2}\cdot\text{h}^{-1}$  (Table 2). Regular cleaning was performed each hour by an initial backwash just with pressurized permeate and then, after some seconds, by a simultaneous air blow into the feed channels. For the backwash a pressurized tank was used. The backwash pressure expands from initially 5 bar to about 2 bar at the end of the regular cleaning. In this way the amount of backwash water remains always the same. The pressure of the air blow is likewise 2 bar. In total the regular cleaning lasted about 10 seconds. The obtained sludge was discharged to the sewer system. The pilot plant also offers the possibility of chemical enhanced backwashing, e.g. by dosing acid, base or chlorine, however, these options were not used or found necessary in the experiments conducted. After each experiment the membrane modules were cleaned intensively by soaking alternating in citric acid solution ( $w = 1 \%$ ) and sodium hypochlorite solution ( $c = 3,000 \text{ ppm}$ ).

Table 2: Membrane operating conditions and module specification

|  |  |
|--|--|
| Membrane type                          | ceramic MF                                       |
| Module length / diameter               | 1 m / 0.03 m                                     |
| Channels per module                    | 55   |
| Channel diameter                       | 2.5 mm   |
| Module area / nominal pore size        | $0.43 \text{ m}^2 / 0.1 \mu\text{m}$             |
| Operational flux                       | $143 \text{ L}\cdot\text{m}^{-2} \text{ h}^{-1}$ |
| Regular cleaning intervals / procedure | 1 h / backwash and air blow                      |

Two different coagulants were compared in this study, polyaluminium chloride (PAX-18) and iron chloride (PIX-111), both supplied by Kemira Chemicals. The process performance was assessed as a function of coagulant type, dosage and pH value. The

DOC and colour removal, membrane fouling and the residual metal concentration in the permeate were measured for evaluation of the process performance. For the polyaluminium chloride (PACL) doses of 2, 3 and 5 mg Al/L were chosen, corresponding roughly to an alum dose between 0.4 and 1 mg Al per mg of DOC. The chosen iron doses were twice as high as for the alum (in order to have same equivalent concentrations), 4, 6 and 10 mg Fe/L, corresponding to an iron dose range between 0.8 and 2 mg Fe per mg DOC. The investigated pH range was from 4.5 to 7 for both coagulants. The hydraulic residence time (HRT) in the coagulation/flocculation tanks was 21 minutes in total, 7 minutes in the rapid mixing tank and 14 minutes in the slow mixing tank respectively. Each condition was tested for at least 72 hours. Table 3 summarizes the applied coagulation conditions.

Table 3: Coagulation conditions

|                             |                               |
|-----------------------------|-------------------------------|
| All experiments             |                               |
| Rapid mixing time / G-value | 6.7 min / 400s <sup>-1</sup>  |
| Slow mixing time / G-value  | 13.3 min / 100s <sup>-1</sup> |
| PACL coagulation            |                               |
| Coagulant dose              | 2, 3 & 5 mg Al / L            |
| Investigated pH-values      | 4.5; 5.0; 5.5; 6.0; 6.5; 7.0  |
| Iron coagulation            |                               |
| Coagulant dose              | 4, 6 & 10 mg Fe / L           |
| Investigated pH-values      | 4.5; 5.0; 5.5; 6.0; 6.5; 7.0  |

Additional experiments were performed to evaluate the influence of the pre-treatment process configuration on the overall process performance. Prior to the membrane filtration unit three different coagulation configurations were compared, a classical two tank coagulation/flocculation setup with a rapid mixing followed by a slow mixing step, a simplified setup containing only rapid mixing and bypassing the slow mixing, and finally an even more simplified inline mixing and pipe coagulation setup. In the inline setup (Figure 2b) the initial mixing of the coagulant with the raw water took place in the membrane feeding pump, followed by a pipe flocculator, which further ensured mixing (G-value 330s<sup>-1</sup>) until the water reached the membrane. The total HRT in the inline mixing was 45 s. For this initial set of experiments conditions beneficial for DOC removal were selected. Iron chloride (PIX-111) was chosen as coagulant, operated at a pH of 5 and an iron dose of 10 mg Fe/L.

*Experimental analysis.* The membrane performance was monitored by logging the transmembrane pressure (TMP) development for constant flux operation. Samples were taken before the coagulation and after the membrane filtration twice a day during different stages in the process cycles. Turbidity measurements (90° scattered light

method, Turbidimeter 2100N, Hach) and the residual metal concentration (measured by High Resolution ICP-MS at the Institute for Chemistry at NTNU) in the permeate were analysed for each sample. The removal of organic matter was monitored by measuring colour, UV-absorption at 254 and 436 nm (Spectrophotometer U-3000, Hitachi) and DOC (Laboratory analyser: Dohrmann Apollo 9000, Teledyne-Tekmar; Online spectrometric probe: Spectro::lyser™, s::can Meßtechnik GmbH, Vienna, Austria).

In this study measurements were conducted to distinguish between reversible and irreversible fouling. By definition, reversible fouling can be removed by regular cleaning procedures without using chemicals whereas irreversible fouling has to be removed by enhanced chemical cleaning. This is usually done when a defined level of the system permeability is undercut.

In the conducted experiments the TMP was measured for each cycle before and after a backwash. The resulting data were linear approximated as shown in Figure 3 and the slope of the regression curves calculated. The slopes represent the actual fouling rate during an experiment, expressed as pressure increase per amount of time with the unit mbar/h. The area under the regression curves can be defined as the total amount of fouling and was estimated by integration of the regression curves. In contrast to the fouling rates the total amount of fouling has the unit mbar\*h. By calculating the area between the two regression curves the amount of reversible fouling in an experiment can be quantified. The obtained values are a measure for the distance between the linear approximated TMP curves and thus a quantification for the degree of reversible fouling during an experiment. At the end, all irreversible fouling rates were subsequently compared to each other and related to the different flocculation conditions applied. For the overall evaluation of the reversible fouling not the fouling rate was used but the total amount of fouling, which contains more information about the filtration resistance build up during an entire experiment compared to the actual fouling rate.

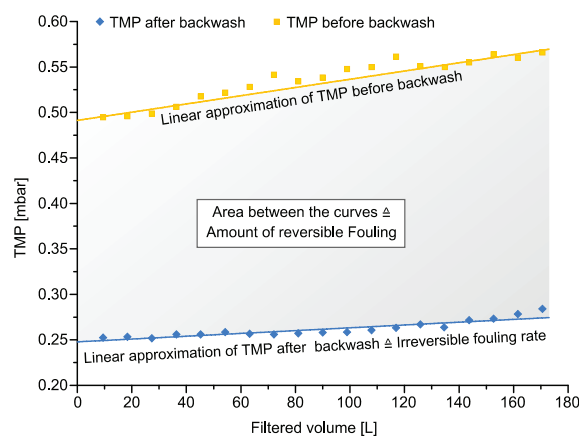
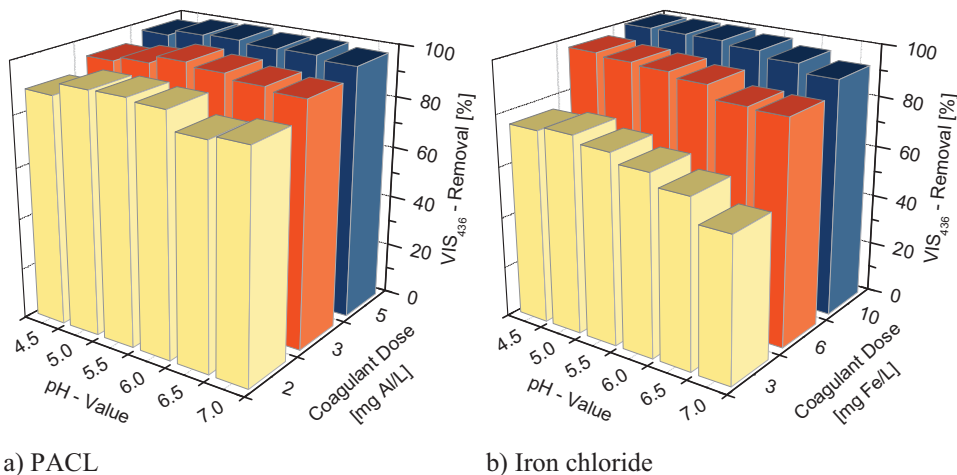

Figure 3: Exemplary calculation of reversible and irreversible fouling

## Results and discussion

*Tank coagulation / flocculation configuration.* Overall, the applied treatment combinations investigated in this study worked all very efficiently. After a short initial phase at the beginning of the experiments the TMP measured was stable for the remaining experimental period. Good colour and DOC removal were achieved.

As shown in Figure 4, more than 90% of the raw water colour ( $VIS_{436}$ :  $1.97 \text{ m}^{-1}$ ) was removed at most of the chosen conditions. For the PACL (Figure 4) a removal maximum was observed around pH 5.5. Above and below that the colour removal decreased. Even with the low alum dose of 2 mg/L a colour removal higher than 90% was achievable at optimal pH. For the iron chloride the colour removal was a bit lower compared to PACL (Figure 4b). To achieve a removal above 90 % a minimum iron dose of 6 mg/L was required. A removal maximum was observed at pH 5 and below.



a) PACL

b) Iron chloride

Figure 4: Colour removal expressed as percentage  $VIS_{436}$  reduction in dependence on pH and coagulant dose

The DOC removal followed a similar pattern as for the colour (Figure 5). For PACL the removal optimum was at pH 5.5 and with a decrease at lower or higher pH-values respectively. The removal varied between 50 and 85 % at these pH levels and increased with higher coagulant doses. For iron chloride the DOC removal optimum was at pH 4.5. At a dose of 3 mg/L only up to 48% of the DOC was removed. Dosages of 6 mg Fe/L and higher were necessary to remove more than 70%. The highest removal with iron chloride was 87% at a pH of 4.5 and an iron dose of 10 mg/L.

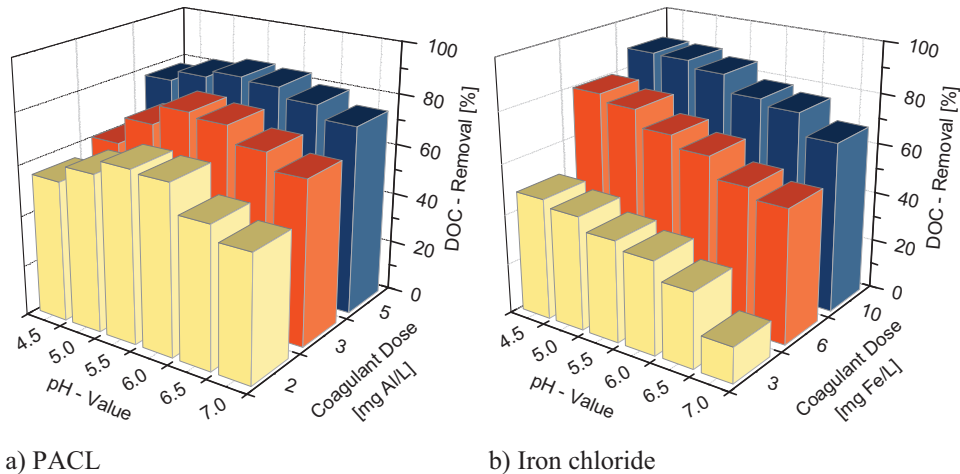

a) PACL

b) Iron chloride

Figure 5: Percentage DOC removal in dependence on pH and coagulant dose (raw water DOC = 5.2 mg/L)

These findings correspond with results reported in previous studies (Koniczny et al., 2006; Lerch et al., 2005). The observed optimal pH values for the removal of NOM are lower than commonly reported for treatment facilities targeting turbidity removal. This is caused by the formation of strongly positively charged hydroxo- and polyhydroxo-complexes which takes place at low pH-values. Especially the poly-complexes show a very strong tendency to attach to the negatively charged surface of NOM. The optimal pH for PIX 111 is with 4.5 lower than for the pre-polymerized PAX 18 with 5.5. However, both coagulants remove colour and DOC over a wider pH range.

Residual metal concentrations in the permeate are strongly depending on the coagulant dosage and the pH values (Figure6). The higher the coagulant dose or the lower the pH, the higher is the residual metal concentration. At pH-values of 6 and below the residual metal concentration exceeds 150  $\mu\text{g/L}$ , the limiting value defined by the Norwegian regulations for both, aluminium and iron. However, low residual iron concentrations can be achieved also at higher coagulant doses, at pH-values above 6.

The residual metal concentrations correlate well with the solubility of aluminium and ferric based metal salts. An optimal pH for solubility values can be defined due to the solubility of the positively charged metal-hydroxo complexes which are present in the water at lower pH-values, compared to the insoluble neutral metal compounds found at a higher pH. However, the optimal pH-values for the removal of NOM are lower than this pH range. The consequence is therefore a narrower pH range of operation to comply with both requirements, removal of NOM and residual metals, making the residual metal concentration a limiting parameter for process optimization.

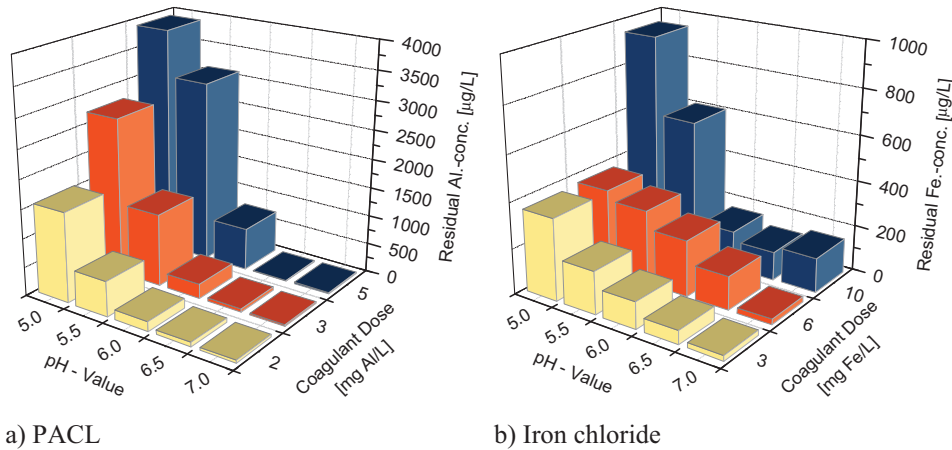

a) PACL

b) Iron chloride

Figure 6: Residual metal concentration in the permeate in dependence on coagulant dosage and pH-Value

Assessment of the membrane filtration performance was made by evaluating TMP measurements for the various operating conditions. Even if the observed irreversible fouling, which is represented by TMP measurements after a backwash, was very low, it was still detectable and depended on the operating conditions. Figure 7b) shows a summary of the membrane performance, expressed as irreversible fouling, in dependence on the different coagulation/flocculation conditions for PACL.

With the application of PACL two trends are clearly visible. Fouling is much lower at an alum dose of 3 mg/L compared to the higher (5 mg/L) and lower dose (2 mg/L). That means that there is an optimum dosage in terms of membrane fouling for this kind of raw water and process configuration used. Since the turbidity in the raw water is very low it can be assumed that the fouling is mostly driven by the organic matter contained in the raw water and by the coagulant itself. At the low alum dose of 2 mg/L possibly the formed aggregates are smaller than at higher doses as i.e. shown by Gregory et al. (2000). The coagulant dose might be too low for neutralizing the negative charge of the organic matter molecules and thus decreasing aggregation and precipitation. Both effects could result in increased membrane pore blockage and lower filterability. At a higher alum dose of 5 mg/L aggregation is improved and the material deposition on the membrane surface is increased. Hence, the load of the membrane might be too high for 1 hour filtration time. Another possibility is that a re-stabilization by charge reversal takes places, again resulting in a decrease of aggregation and precipitation, leading to increased fouling. This explanation would be valid only for pH-values below 6 to 6.5, since only in that pH range charge neutralization is the dominating removal mechanism. Above that, the dominating removal mechanism changes to enmeshment and metal hydroxide precipitation.



Secondly, for using PACL a maximum of irreversible fouling can be observed around a pH range of 5.5 to 6.5. Below and above that range the fouling rates decrease. Since the fouling in this study is mostly caused by NOM, a good correlation between the removal of organic matter (Figure 5a) and the irreversible fouling rates (Figure 7b) can be observed. We also observe a DOC removal maximum in that pH range. However, it can be stated that at an operating flux of  $143 \text{ L}\cdot\text{m}^{-2}\cdot\text{h}^{-1}$  and in dependence on the selected coagulation conditions, irreversible membrane fouling can be kept at a low level and stable operation is achievable.

Reversible fouling, which is defined as the amount of fouling which can be cancelled by normal backwashing and quantified in this study by calculating the area between the two linearly approximated TMP curves before and after backwashing (compare with Figure 3), was detected only in small amounts during all experiments (Figure 7a). At some conditions the reversible fouling was higher than the average. At a pH of 7 and an aluminium dose of 2 mg/l i.e. the amount of reversible fouling was 2788 mbar\*h. Keeping in mind that the cycle length was 1 hour and the experimental duration 72 hours, this means that the average pressure build up during a cycle was around 40 mbar, which is rather low. Thus, not much filtration resistance was built up during a filtration cycle. Therefore, the applied cycle length of one hour might be extendable and consequently an increased process efficiency achievable.

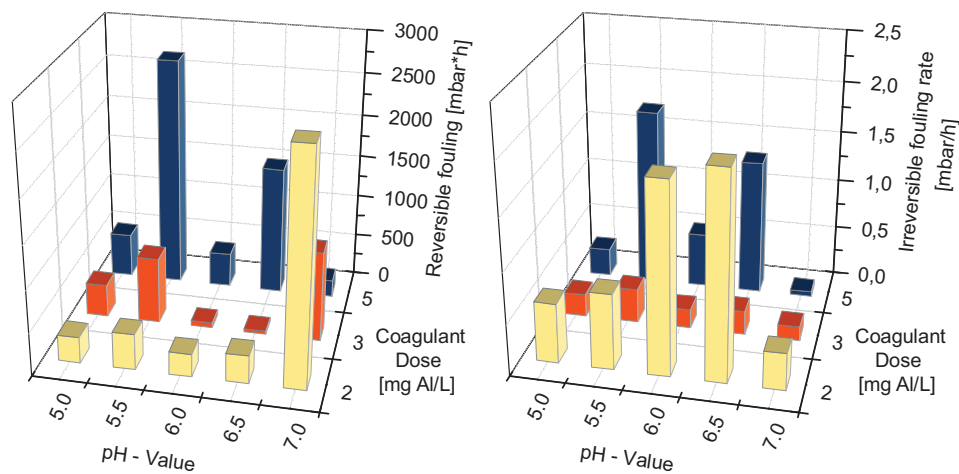

a) Total reversible fouling

b) Irreversible fouling rate

Figure 7: Membrane performance in dependence on pH and coagulant dose (for PACL)

The permeate turbidity was consistently measured below 0.1 NTU for all experimental runs, indicating a very good particle removal capacity of the applied process combination.

Summarizing, it can be said that efficient operation, meaning a maximization of organic matter removal and a simultaneously minimization of membrane fouling and residual metal concentration, is very well achievable with the investigated process combination. Comparing with Figure 5 again, an efficient removal of DOC can be achieved at higher pH-values and with a very low dosage of coagulant. This, combined with not too high or too low coagulant dose minimizes also the membrane fouling (Figure 7). The coagulation/membrane filtration process therefore can be operated at higher pH's and low coagulant dosages with low membrane fouling and still meet required efficiency.

*Comparison of different pre-treatment configurations.* NOM was efficiently removed independently from the chosen pre-treatment options. Direct comparison of the three different setups showed an almost similar colour and DOC removal rate, i.e. of around 80 % at an iron dose of 10 mg / L and a pH-value of 5, as shown in Figure 8a)+b). This is especially remarkable considering the very short hydraulic retention time of only 45 s in the pipe flocculator using the inline configuration, compared to 21 minutes in the conventional setup and 7 minutes in the configuration containing only the rapid mixing.

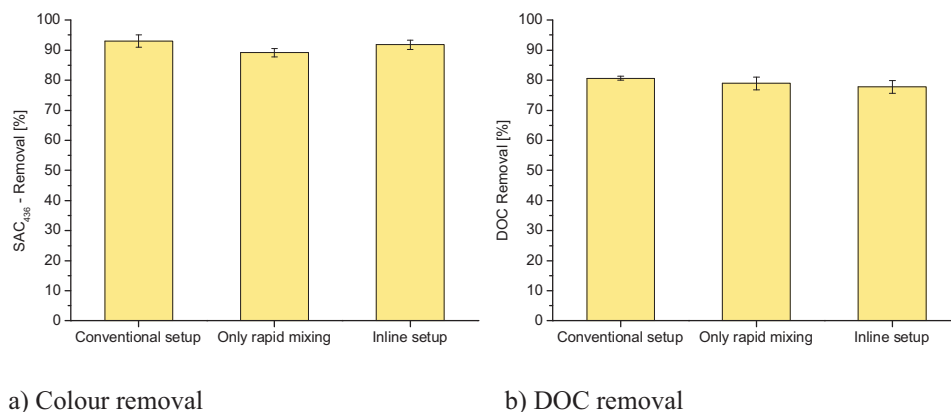

a) Colour removal

b) DOC removal

Figure 8: Colour & DOC removal in dependence on the pre-treatment setup (Iron dose of 10 mg / L, pH 5)

The irreversible membrane fouling also did not show a significant difference as shown in Figure 9a). Although the irreversible fouling rate was with 0.10 mbar/h higher in the inline configuration than in the other two setups, it was still well within the range of fouling rates found in the first set of experiments using the conventional setup, shown in Figure 7b). However, the problem with high residual metal concentrations in the permeate at low pH-values and high coagulant doses remains. Since in this experiment a rather low coagulation pH of 5 was chosen, high metal residues were found independent from the pre-treatment configuration (Figure 9b). The example shown is to illustrate the

relationships found. However, for practical implementation it is necessary to choose operating conditions that comply with the residual metal concentration regulations.

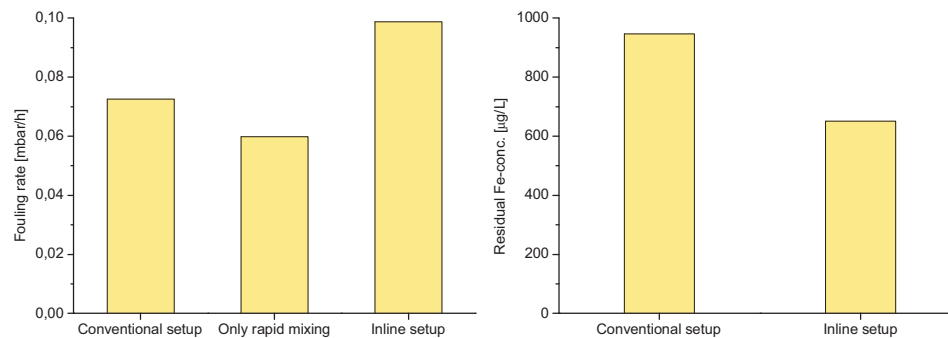

a) Irreversible fouling rate

b) Residual iron concentration

Figure 9: Membrane performance and residual metal concentration in the permeate in dependence on the pre-treatment setup

It can be assumed that the particles formed in the pipe flocculator are large enough to be retained by the membrane, do not cause pore blocking, and do not have a characteristic which increases membrane fouling due to changes in cake layer properties. This observation can be supported by the consideration that the 1 meter long and 2.5 mm membrane channels have such a flow pattern, that they can work as a pipe flocculator themselves (Yonekawa et al., 2004). They therefore support a further floc development and promote a dense columnar cake layer at the dead-end points, but alleviate cake layer formation on the rest of the membrane surface.

### Conclusions

The conducted experiments confirm that the combination of coagulation/flocculation and ceramic membrane filtration is an efficient and reliable option for the drinking water treatment of surface waters with high NOM concentrations. Very good DOC and colour removal can be achieved at relatively low coagulant dosages. This removal, however, strongly depends on the coagulation pH value in which a pH range is preferred between 5 and 6. Residual metal concentration in the permeate increases in this pH region, and operation at higher pH values is therefore necessary to comply with regulation standards on acceptable concentration levels. Sufficient DOC and colour removal is also obtainable at elevated pH and low coagulant dosage. The residual metal concentration is one limiting parameter of the in this study investigated treatment concept and narrows down the choice of operating conditions.

Too low and too high coagulant doses cause increased irreversible fouling and therefore reduce the operation time of the membrane modules. Coagulant dose optimization is

therefore mandatory. Even though at higher coagulant doses more DOC can be removed, the simultaneously increased irreversible fouling has to be taken into account, since the additional DOC removal might be not that high and strongly depends on other operation conditions like the pH.

An initial experiment testing a simplified inline configuration showed very good process performance compared to a classical tank coagulation/flocculation setup. This may be facilitated due to a unique flow pattern inside the membrane modules. Using inline coagulation more compact full scale units can be build, using less space compared to conventional sand filtration units or even membrane filtration plants using tank coagulation / flocculation.

#### **Acknowledgments**

The authors would like to thank Metawater, Japan for providing the filtration pilot plant and the ceramic membranes. S::can Messtechnik GmbH, Vienna, Austria, is acknowledged for providing the spectrometric probe, making an online treatment process monitoring possible. The Norwegian Research Council and the TECHNEAU project we would like to thank or their financial support.

#### **References**

- Chen, W., Westerhoff, P., Leenheer, J.A., Booksh, K., 2003. Fluorescence excitation - Emission matrix regional integration to quantify spectra for dissolved organic matter. *Environmental Science & Technology* 37 (24), 5701-5710.
- Cho, M.H., Lee, C.H., Lee, S., 2006. Effect of flocculation conditions on membrane permeability in coagulation-microfiltration. *Desalination* 191 (1-3), 386-396.
- Forsberg, C., 1992. Will an Increased Greenhouse Impact in Fennoscandia Give Rise to More Humic and Colored Lakes. *Hydrobiologia* 229 (51-58).
- Gregory, J., Rossi, L., Bonnechi, L., 2000. Monitoring Floccs Produced by Water Treatment Coagulants, in: Hahn, H.H., Hoffman, E., Ødegaard, H. (Eds.), *Chemical Water and Wastewater Treatment VI*. Springer Verlag, pp. 57 - 65.
- Hongve, D., Riise, G., Kristiansen, J.F., 2004. Increased colour and organic acid concentrations in Norwegian forest lakes and drinking water - a result of increased precipitation? *Aquatic Sciences* 66 (2), 231-238.
- Kim, J.S., Akeprathumchai, S., Wickramasinghe, S.R., 2001. Flocculation to enhance microfiltration. *Journal of Membrane Science* 182 (1-2), 161-172.

Kimura, K., Maeda, T., Yamamura, H., Watanabe, Y., 2008. Irreversible membrane fouling in microfiltration membranes filtering coagulated surface water. *Journal of Membrane Science* 320 (1-2), 356-362.

Konieczny, K., Bodzek, M., Rajca, M., 2006. A coagulation - MF system for water treatment using ceramic membranes. *Desalination* 198 (1-3), 92-101.

Lahoussine-Turcaud, V., Wiesner, M.R., Bottero, J.Y., Mallevalle, J., 1990. Coagulation Pretreatment for Ultrafiltration of a Surface-Water. *Journal American Water Works Association* 82 (12), 76-81.

Lee, S., Cho, J., 2004. Comparison of ceramic and polymeric membranes for natural organic matter (NOM) removal. *Desalination* 160 (3), 223-232.

Leiknes, T., Lazarova, M., Odegaard, H., 2005. Development of a hybrid ozonation biofilm-membrane filtration process for the production of drinking water. *Water Science and Technology* 51 (6-7), 241-248.

Leiknes, T., Odegaard, H., Myklebust, H., 2004. Removal of natural organic matter (NOM) in drinking water treatment by coagulation-microfiltration using metal membranes. *Journal of Membrane Science* 242 (1-2), 47-55.

Lerch, A., Panglisch, S., Buchta, P., Tomitac, Y., Yonekawa, H., Hattori, K., Gimbel, R., 2005. Direct river water treatment using coagulation/ceramic membrane microfiltration. *Desalination* 179 (1-3), 41-50.

Machenbach, I., 2005. NOM-removal using coagulation and immersed hollow-fibre membrane filtration, in: Østerhus, S.W., Eikebrokk, B. (Eds.), SINTEF report / SINTEF, Technology and Society, Water and Environment. SINTEF, Technology and Society, Water and Environment, Trondheim, Norway.

Nasjonalt folkehelseinstitutt, 2004. Vannforsyningens ABC. Nasjonalt folkehelseinstitutt, Pb 4404 Nydalen, 0403 Oslo, Oslo.

Peuchot, M.M., Ben-Aim, R., 1992. Improvement of Cross-Flow Microfiltration Performances with Flocculation. *Journal of Membrane Science* 68 (3), 241-248.

Ratnaweera, H., Gjessing, E., Oug, E., 1999. Influence of physical-chemical characteristics of natural organic matter (NOM) on coagulation properties: An analysis of eight Norwegian water sources. *Water Science and Technology* 40 (9), 89-95.

Weber, R., Chmiel, H., Mavrov, V., 2003. Characteristics and application of new ceramic nanofiltration membranes. *Desalination* 157 (1-3), 113-125.

Yamamura, H., Kimura, K., Watanabe, Y., 2007. Mechanism involved in the evolution of physically irreversible fouling in microfiltration and ultrafiltration membranes used for drinking water treatment. *Environmental Science & Technology* 41 (19), 6789-6794.

Yonekawa, H., Tomita, Y., Watanabe, Y., 2004. Behavior of micro-particles in monolith ceramic membrane filtration with pre-coagulation. *Water Science and Technology* 50 (12), 317-325.

Ødegaard, H., Eikebrokk, B., Storhaug, R., 1999. Processes for the removal of humic substances from water - An overview based on Norwegian experiences. *Water Science and Technology* 40 (9), 37-46.

Ødegaard, H., Thorsen, T., Melin, E., 2000. Practical experiences from membrane filtration plants for humic substance removal. *Water Science and Technology* 41 (10-11), 33-41.

## 6.2 Publication 2

The following paper “Significance of flocculation for NOM removal by coagulation - ceramic membrane microfiltration”, written by Thomas Meyn, Anna Bahn and Tor Ove Leiknes, was published 2008 in *Water Science and Technology: Water Supply*, Volume 8(6).

Encouraged by promising primary results, the idea of simplifying the coagulation pre-treatment was investigated further. Initially, 3 different pre-treatment setups were investigated, a conventional tank coagulation containing rapid and slow mixing, a simplified tank coagulation only containing rapid mixing and an inline coagulation setup. Since the drastically simplified setup showed the same NOM removal as the other 2 pre-treatments, a parameter study was performed investigating this configuration further. The process performance, expressed as a function of DOC and colour removal, residual metal concentration, was investigated in dependence on the variables coagulant dosage, pH value, flocculation time and G-value. The membrane flux was also varied in order to push the system to its limits. In this study FeCl was the only coagulant investigated.





### **Significance of flocculation for NOM removal by coagulation - ceramic membrane microfiltration**

**T. Meyn<sup>\*</sup>, A. Bahn<sup>\*\*</sup> and T. O. Leiknes<sup>\*</sup>**

<sup>\*</sup>NTNU - Norwegian University of Science and Technology, Department of Hydraulic and Environmental Engineering, S.P. Andersensvei 5, 7491 Trondheim, Norway

<sup>\*\*</sup>Technical University Berlin, Department for chemical engineering, Straße des 17. Juni 135, 10623 Berlin, Germany

(E-mail: *thomas.meyn@ntnu.no*)

**Abstract** Potable water treatment with coupling coagulation - microfiltration processes are still rarely applied in commercial treatment plants. Raw water with a high content of organic matter, typical for Norwegian surface water sources, was treated in this study using a ceramic microfiltration membrane system. Three different pre-treatment options were investigated, a classical two stage flocculation, a simplified one-stage fast mixing step and an inline flocculation treatment, using an iron chloride coagulant. DOC removal was similar (76-81%, 5.5 mg C/L in raw water) in all compared setups. The more compact, energy efficient inline configuration was investigated further, varying flux (140 and 220 L/(m<sup>2</sup> h)), pH (4.5, 5.5 & 6.5), G-value (60 and 300 s<sup>-1</sup>) and HRT in the pipe (7 and 30 s), while monitoring DOC removal, fouling rate and residual iron concentrations. DOC removal was strongly pH dependent; 70 % at pH 4.5, and 47 % at pH 6.5. At high flux of 220 L/(m<sup>2</sup> h) the membrane fouled quickly and sustainable operation was not possible. At 140 L/(m<sup>2</sup> h) fouling was much less and no severe fouling was observed during the experimental period. Residual metal concentration was found to be the limiting parameter in the design and operation of the process configuration. Metal concentrations below the regulation limits (200 µgFe/L) were only achieved at pH 6.5. Reversible fouling was only observed at higher pH-values.

**Keywords** Ceramic membranes; flocculation; microfiltration; drinking water; natural organic matter

#### **Introduction**

Production of potable water from surface water sources can be a challenge due to many factors. Climatic and geographical conditions have given Norway an abundance of water resources and about 90% of drinking water supplies in Norway are from surface water, mostly lakes with very low turbidity. One of the major problems of using these surface waters in northern climates is high content of natural organic matter (NOM), resulting in high colour and total organic carbon (TOC) concentrations. Even though NOM is generally not harmful itself, removal of NOM is required since coloured water is unattractive to consumers, results in colouring of clothes during washing, can cause

odour and taste, increases corrosion and biofilm growth in the distribution network, and is a precursor to the formation of disinfection by-products (DBP) when water is disinfected. NOM also forms complexes with heavy metals and organic micropollutants, affects stability and removal of particles and pathogens, and can affect the unit processes in a treatment scheme in various ways (*i.e.* increased coagulant dosages, sludge production). The use of surface water with high NOM content is also of concern as recent studies have documented a steady increase in the content of NOM in natural waters in Norway over the last 30 years (Forsberg, 1992; Hongve et al, 2004). This is not unique to Norway, and a need for more efficient removal of NOM and more NOM tolerant treatment technologies is foreseen.

The most common drinking water treatment plant designs in Norway are based on coagulation and direct filtration or nanofiltration (NF) membrane filtration processes. Coagulation direct filtration plants (enhanced coagulation) are still the dominant treatment plant design option, however, in the last 15 years membrane processes based on NF spiral wound module configurations have been successfully used, with approximately 100 plants in operation today. Alternative treatment schemes to these options are the use of microfiltration (MF) and ultrafiltration (UF) membranes, using alternative membrane module designs (*i.e.* hollow fibre cross-flow modules, submerged modules). Studies are also found that report and demonstrate the advantages and benefits of combining coagulation pre-treatment with membrane filtration when UF and MF membranes are used. Pre-treatment by coagulation has been reported to be a potential strategy to reduce and control fouling, an inherent challenge in all membrane processes. Common for all of these studies are that they are based on polymeric membranes (Lahoussine-Turcaud, 1990; Peuchot et al, 1992; Lebeau et al, 1998; Kim et al, 2001; Schäfer et al, 2000; Machenbach et al, 2002). The more energy efficient, low pressure MF/UF membrane plant configurations also appear to be the preferred solution. Due to their physical properties, mechanical stability and resistance against chemicals, there is an increasing interest in using inorganic ceramic membranes for NOM removal (Weber et al, 2003; Lee et al, 2004; Leiknes et al, 2004). The effect of higher investment costs of ceramic compared to organic membranes can be diminished by operating ceramic membranes with higher fluxes and by achieving good membrane fouling control/mitigation. In an ongoing study, the combination of ceramic microfiltration with coagulation/flocculation pre-treatment has been investigated for typical Norwegian surface water treatment and it has been demonstrated that high DOC and colour removals using iron chloride and polyaluminium chloride as coagulants, operating at optimal dose and pH conditions, can be achieved (Meyn et al, in press). Results show that DOC and colour removal can be achieved at relatively low coagulant dosages, however, this strongly depends on the coagulation pH and good flocculation conditions.

In this study the significance of flocculation on NOM removal for a coagulation/flocculation and ceramic microfiltration treatment scheme was investigated. The aim of the study was to investigate various modes of flocculation on NOM removal and to investigate the influence of operating parameters such as coagulant dose, pH-value, G-value on the flocculation step and how this affects the overall performance of the membrane filtration process.

### Methods

**Raw water production.** The raw water for all conducted experiments was prepared using a NOM concentrate from a full scale ion exchange treatment plant, which was mixed with tap water to make up an analogue water representative for typical Norwegian raw water sources (Machenbach et al, 2002; Leiknes et al, 2004; Meyn et al, in press). The analogue feed composition consisted of water with a colour of  $50 \pm 1.13$  mg/L Pt at pH 7,  $UV_{254}$ -adsorbance of  $24.6 \pm 0.8$  m<sup>-1</sup> and DOC concentration of  $5.5 \pm 0.3$  mg/L C.

**Pilot plant.** A coagulation/flocculation membrane filtration pilot plant supplied by NGK, Japan, was applied in this study. It contains three independent controllable process trains thereby allowing different flocculation modes and operating conditions to be investigated in parallel. The chosen options investigated consisted of a classical two-stage flocculation with a fast mixing tank followed by a slow mixing tank, a simplified one-stage flocculation with a fast mixing tank, and a simplified inline pipe flocculation device. Figure 1 shows a schematic of the experimental setup - A: classical two-tank and one-tank process configuration, B: simplified inline pipe flocculation. In the last design, a pipe flocculator followed the feed pump to the membrane filtration unit. In this mode the feed pump was also utilized as the mixing device for adding the coagulant.

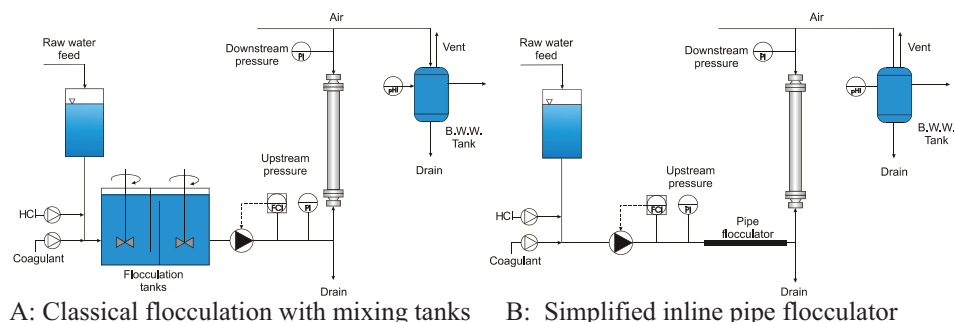

A: Classical flocculation with mixing tanks B: Simplified inline pipe flocculator  
Figure 1: Schematic of the pilot plant configuration showing the three flocculation modes

In this study, multi-channel ceramic membranes operated in dead-end / inside-out mode with a nominal pore size of 0.1  $\mu$ m were used. Each module has 55 channels, a length of

1.0 m, giving an effective area of 0.43 m<sup>2</sup>. The membrane module is closed at one end (dead-end operation) and feed water is pumped into the membrane in an up-flow direction, operated in constant flux mode. Backwashing was performed with permeate after a filtration cycle of 1 hour (Table 1). During the backwashing process, the backwash water storage tank is pressurised (500 kPa) and permeate is pushed in reverse through the membrane, followed by a short blast of pressurised air (200 kPa) at the top of the module, the whole procedure taking about 10 seconds. Between each experiment the membrane modules were cleaned intensively using a chemical cleaning protocol based on soaking the membrane in citric acid solution (1%) and then sodium hypochlorite solution (3 mg/L). Clean water permeability was measured to verify removal of all foulants after cleaning and to ensure the same starting conditions for all tests. The permeability was fully restored after each enhanced chemical cleaning.

Table 1: Membrane module specifications

| Parameter and unit                 | Ceramic MF                         |
|------------------------------------|------------------------------------|
| Length [m]                         | 1                                  |
| Module diameter [m]                | 0.03                               |
| Channels per module                | 55                                 |
| Channel diameter [mm]              | 2.5                                |
| Module area [m <sup>2</sup> ]      | 0.43                               |
| Nominal pore size [µm]             | 0.1                                |
| Backwash intervals [h]             | 1                                  |
| Backwash procedure/ pressure [bar] | Filtrate at 5 bar and air at 2 bar |

*Experimental conditions.* A parametric study was performed for the simplified inline setup, investigating the influence of the flocculation parameters pH-value, HRT and G-value in the pipe flocculator on the process parameters DOC removal, residual metal concentration and membrane fouling. Different pipe flocculators were used, tubes of different length and diameter, to obtain varying retention times and G-values depending on the experimental conditions desired. This was investigated for two flow rates, 1.0 and 1.6 L/min, corresponding to membrane fluxes of 140 and 220 LMH respectively. An iron chloride coagulant (PIX-111, Kemira Chemicals) was used, constant dose of 6 mg Fe/L, for all experiments conducted. Table 2 gives an overview of the combinations of operating conditions tested. For one experiment all three trains were set up with the same experimental conditions except for pH, which was set at 4.5, 5.5 and 6.5 respectively. To exclude potential bias by train or membrane module specifics, distribution of parameters between the three trains was randomized. Each experimental run was terminated when TMP exceeded 200 kPa or a set maximum operating time of 96 hours was reached.

Table 2: Matrix of experimental conditions and combinations tested

| Coagulant dose<br>[mg Fe / L] | Flow / Flux<br>[L/min] / [LMH] | G-Value<br>[1/s] | Tube diameter<br>[cm] | Retention time<br>[s] | Tube length<br>[m] | pH<br>[]        |
|-------------------------------|--------------------------------|------------------|-----------------------|-----------------------|--------------------|-----------------|
| 6                             | 1.0 / 140                      | 60               | 1.3                   | 30                    | 3.77               | 4.5 / 5.5 / 6.5 |
| 6                             | 1.0 / 140                      | 60               | 1.3                   | 7.5                   | 0.94               | 4.5 / 5.5 / 6.5 |
| 6                             | 1.0 / 140                      | 300              | 0.8                   | 30                    | 9.95               | 4.5 / 5.5 / 6.5 |
| 6                             | 1.0 / 140                      | 300              | 0.8                   | 7.5                   | 2.49               | 4.5 / 5.5 / 6.5 |
| 6                             | 1.6 / 220                      | 60               | 1.6                   | 30                    | 3.98               | 4.5 / 5.5 / 6.5 |
| 6                             | 1.6 / 220                      | 60               | 1.6                   | 7.5                   | 0.99               | 4.5 / 5.5 / 6.5 |
| 6                             | 1.6 / 220                      | 300              | 0.8                   | 30                    | 10.19              | 4.5 / 5.5 / 6.5 |
| 6                             | 1.6 / 220                      | 300              | 0.8                   | 7.5                   | 2.55               | 4.5 / 5.5 / 6.5 |

*Analytical equipment / instruments.* Membrane performance was monitored by logging the TMP development for constant flux operation over time (National Instruments FieldPoint, LabVIEW 8.0). Water samples were taken before the coagulant dosage point, the feed water to the membrane and of the permeate twice a day during different stages in the process cycles. Turbidity measurements (90° scattered light method, Turbidimeter 2100N, Hach) and the residual metal concentration (measured by High Resolution ICP-MS) in the permeate were analysed for each sample. The removal of organic matter was monitored online by measuring colour, UV-adsorption at 254 and 436 nm and DOC (Spectro::lyser™, s::can Meßtechnik GmbH, Vienna, Austria).

*Presentation of results.* Obtained results were visualized in effect plots and interaction plots. The effect plot is a plot of means of a response, *i.e.* the residual DOC concentration in the permeate at each level of a factor, *i.e.* pH-value. Plots give a general idea of which effects may be important and which can be neglected. To construct such a plot, all obtained results are grouped in dependence on the level of the plotted factor, *i.e.* if obtained at high or low pH, and averaged. The horizontal line represents the grand mean, which means the average of all observations of the plotted response. All plots within one diagram have the same magnitude, making the influence of different factors on the same response comparable. An effect occurs when the mean response changes across the levels of a factor. Effect plots cannot be interpreted separately from interaction plots, because some effects only occur at a single condition, but are intensive enough to dominate the overall average. An interaction takes place when the effect of one factor depends on the level of another factor. It occurs when the change in response from the low level to the high level of one factor is not the same as the change in response at the same two levels of a second factor. This can be visualized in interaction plots. Parallel lines in a plot symbolize no interaction. The greater the difference in slope between the lines, the higher is the interaction. Each row of windows

in the plot illustrates the impact of a certain parameter. Results from the study are predominantly presented in this manner.

*Evaluation of fouling rate.* In this study measurements were conducted to distinguish between reversible and irreversible fouling. By definition, reversible fouling can be removed by normal backwashing procedures whereas irreversible fouling has to be removed by enhanced chemical cleaning when a defined level for the system is reached. The TMP for each cycle before and after a backwash was measured, where the area difference between the two curves is defined as reversible fouling (see Figure 4). To quantify the actual amount of fouling, or fouling rate, TMP curves measured were approximated by the exponential function;

$$TMP = R_0 e^{kV} \quad (1)$$

where  $R_0$  represents the initial TMP and  $k$  the fouling rate. The fouling rate  $k$  of the irreversible fouling curves were then used for the overall fouling rate evaluation in relation to the different applied flocculation conditions and subsequently compared to each other.

To check the quality of the exponential approximation used in the data analysis, the difference of the TMP measured after filtering a volume of 4000 L compared to the initial TMP at the start of the experiment was calculated and compared to the ones calculated with the model. Measured and predicted values showed a good linear correlation, and it was, therefore assumed that the expression in equation 1 was a suitable approximation to determine the fouling rates measured in this study for the various operating conditions tested. To assess the amount of reversible fouling the area under both, the reversible and irreversible fouling curves was calculated with help of exponential approximation and the area difference calculated.

## Results and discussion

*Assessment of the three treatment trains.* Three options were chosen as alternatives to apply the coagulation and flocculation stages in the treatment process and investigated under similar conditions. The aim of the evaluation was to assess the significance of the flocculation step for the overall performance of the treatment scheme, *i.e.* DOC removal efficiency and membrane filtration fouling rates. A classical two-stage flocculation unit was compared to a simplified one-stage flocculation, and with an inline pipe flocculation. The two-stage treatment train included a rapid mixing reactor (193 rpm) with a hydraulic retention time (HRT) of 6.7 minutes, followed by a slow mixing tank (53 rpm) with a HRT of 13.3 minutes, in total 20 minutes. The one-stage flocculation included only the fast mixing stage, HRT 6.8 minutes, before feeding the water to the membrane filtration unit. The pipe flocculator was operated with a G-value around 7.5s

and HRT of 0.75 minutes. All three flocculation setups compared gave similar DOC removal efficiencies (76-81%), although the HRT within the respective flocculation steps was significantly different (0.75-20 min). Overall results are illustrated in Figure 2.

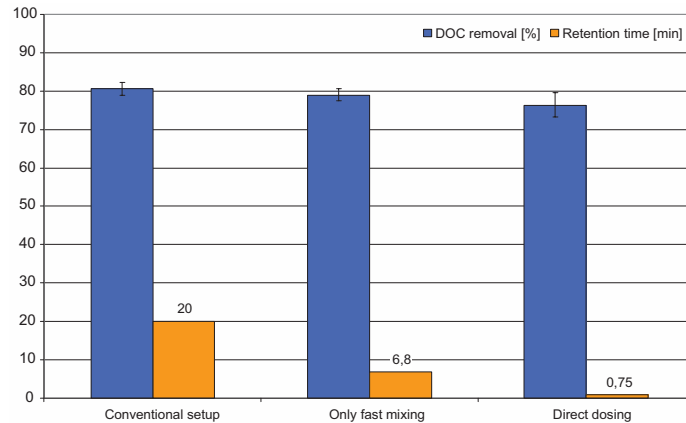

Figure 2: DOC removal and hydraulic retention time for the three treatment trains investigated

Based on the results observed it may appear as though flocculation is not a significant operating parameter for efficient removal of DOC under the conditions tested. In addition, the use of an inline pipe flocculator potentially represents a more compact treatment plant with fewer unit processes, simpler to operate and thus requiring less energy. Further studies were therefore conducted to evaluate the significance of flocculation in the treatment scheme and to assess the applicability of an inline unit with respect to process performance. The following discussion of results is based on this assessment.

*Inline flocculation – membrane fouling.* Fouling of the membrane was found to be strongly flux dependent. Operating with a flow rate of 1.6 L/min, (corresponding flux 220 LMH), the membrane was severely fouled after a small filtration volume due to the higher load of the membrane. Another reason for this could be that during all the experiments a constant backwash interval of 1 hour was applied, thus, at the higher flow rate the membrane was backwashed after filtration of 100 L water compared to 60 L at the low flow rate. The higher flow rate might also cause a denser cake. Fouling was less pronounced depending on the applied coagulation conditions, but overall too strong to consider this flux for a sustainable process operation. Most of the experiments had to be stopped before the set target volume of 4000 L was filtered, with only one experiment continuing until 7000 L. As expected, operating at the lower flux of 140 LMH, the membrane showed much better performance (*i.e.* less fouling) and it was possible to run

the experiments much longer before fouling development became too severe. In all cases operating with a flux of 140 LMH a total filtered volume in excess of 7000 L was achieved. Subsequently, for the two fluxes chosen, fouling rates observed at 140 LMH were much lower compared to 220 LMH (Figure 3). For the evaluation of results, TMP development was related to the permeate volume to derive the fouling rate and not to filtration time, since this would not reflect the higher membrane load after changing from a low to a high flow rate.

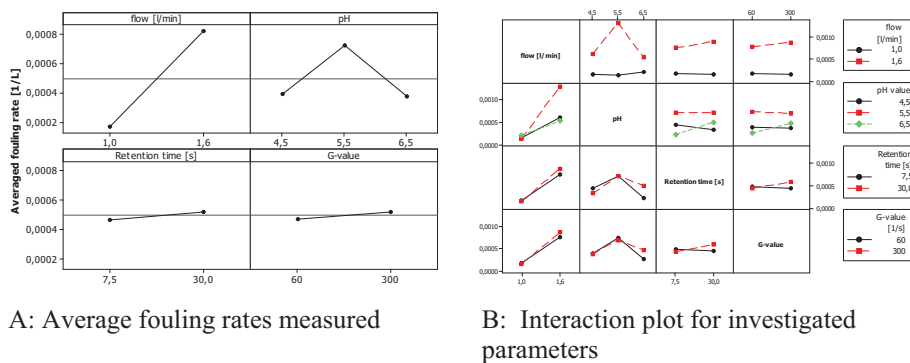

Figure 3: Average fouling rates as a function of tested operating conditions

In addition to flow rate, pH also had a strong influence on the membrane fouling. Particularly at a pH 5.5 the membrane fouled very quickly, while at the higher and lower pH fouling was less severe. This effect was only observed at the higher applied flow rate of 1.6 L/min (Figure 3) and not at the lower flow rate of 1.0 L/min. As for results for DOC removal, flocculation conditions at the lower flow rate appear to be advantageous since no pH influence on the membrane fouling was found. The high fouling rates measured at high flow and pH 5.5 can possibly be explained by unfavourable changes in floc and cake characteristics. Combining all the negative effects under these operating conditions this phenomenon may be explained by: the higher volume of water filtered during a cycle, the lower retention time in the membrane, and a possibly denser cake due to changed floc properties. The mechanistic change of the coagulation mechanism may be the cause as at pH higher than 6.5 sweep coagulation dominates, and changes to adsorption destabilization below pH 6 for the applied iron dose of 6 mg Fe/L. Interestingly, no special effects were observed at this pH for DOC removal or residual metal results measured.

The retention time and the G-value displayed only a minor influence on the membrane performance, however, the influence was slightly more pronounced for the higher flow rate applied. A lower G-value and retention time appear to be slightly more beneficial for the membrane performance in this case. From the interaction plot in Figure 3, it is apparent that both G-value and retention time have a higher influence on membrane



fouling at pH 6.5. This might indicate that under sweep coagulation conditions these parameters have a higher influence than on destabilization conditions. At this pH the flocs possibly become smaller at a higher G-value and build up a denser cake, whereas during adsorption destabilization conditions the flocs are smaller anyway and are not changed very much by the set up flocculation conditions.

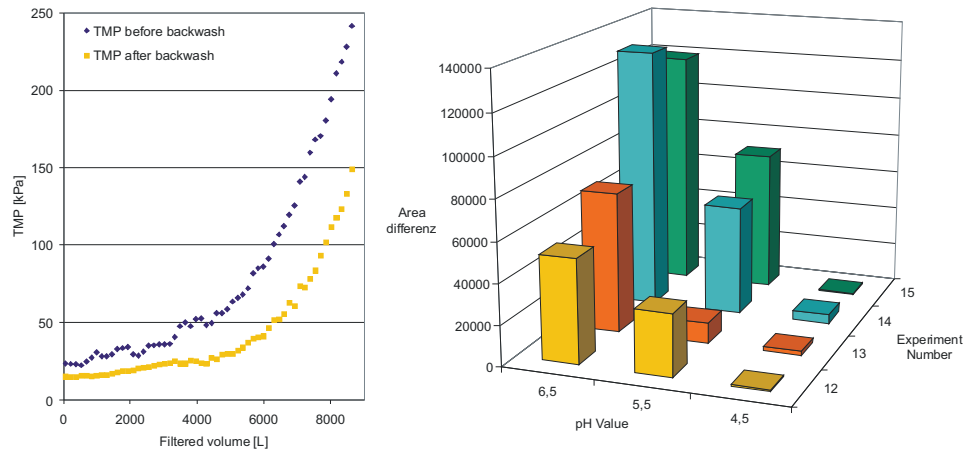

A: Sample measurement of reversible and irreversible fouling

B: Overview of reversible fouling dependence on pH

Figure 4: Analysis of fouling rates as a function of tested operating conditions

A strong correlation between the amount of reversible fouling and the applied pH was measured (Figure 4). With increasing pH a stronger pressure increase during a cycle was observed, whereas the TMP after backwashing, which represents the irreversible fouling expressed by the fouling rate, was more or less constant. This was observed under all applied conditions and is probably due to the different coagulation mechanisms at different pH values. At a pH of 6 more particles and turbidity might be enmeshed due to sweep coagulation, resulting in a good removable but resistance causing cake layer, whereas at lower pH the cake contains more NOM aggregates, forming a denser but thinner cake.

*DOC removal.* Depending in the applied flocculation conditions, between 54 and 63 % of DOC was removed from the raw water, feed concentration 5.8 mg/L DOC. All four investigated factors have a considerable influence on the DOC removal (Figure 5). As shown in further studies, the DOC removal is strongly dependent on the applied pH value (Meyn et al, in press). Best DOC removal was achieved at the lowest applied pH of 4.5 and the lowest removal at pH 6.5. This can be explained by the more efficient reaction of NOM molecules with the iron hydroxocomplexes, which are more stable at lower pH values.

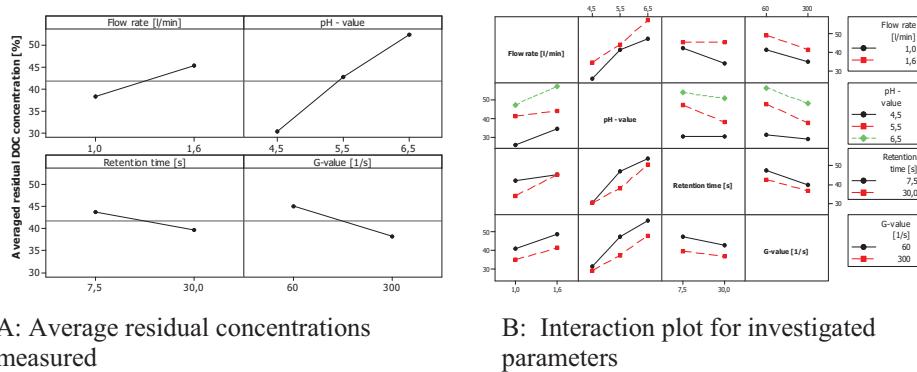

Figure 5: Residual DOC concentrations as a function of tested operating conditions

At the higher flow rate more DOC was found in the membrane permeate. Since all the experiments were carried out with two different flow rates but under otherwise same flocculation conditions this difference can only be explained with the changed hydraulic conditions in the membrane channels. Laminar flow conditions can be assumed in the membrane channels for both conditions since the average Reynolds number increases from ca. 150 to 250, which is still in the laminar range. At the lower flow rate of 1.0 L/min (corresponding to flux 140 LMH), the flocs have more time to interact within the membrane where the internal channels induce a kind of pipe flocculation. As reported by Yonekawa et al (2004), this has a significant effect on the floc development and the removal performance is substantially improved. Due to a unique flow pattern in the membrane channels micro-particles increase in size through aggregation in the course of concentration near the membrane surface, followed by back diffusion from the membrane surface into the bulk flow by shear-induced lift force. The flocs then form a cake layer at the dead-end points of the membrane. This effect might be reduced by an increased fluid flow in the channels which causes a reduction in residence time and increased turbulence.

Results show that both the retention time and the G-value in the pipe flocculator also have a strong effect on the DOC removal. Lower residual DOC concentrations, and therefore better removal, was measured with a higher retention time and a higher G-value. A longer retention time in the pipe flocculator allows the flocs to have more time for development, which is beneficial for the DOC removal. Applying higher G-values smaller but more stable flocs can be obtained, which then do not get destroyed while entering the membrane and can interact with the membrane surface (Yonekawa et al, 2004).

The interaction plot in Figure 5 reveals a relationship between the flow rate and the retention time. At the higher flow rate of 1.6 L/min (corresponding flux 220 LMH), the

retention time does not appear to have any influence on the DOC removal. At the lower flow of 1.0 L/min (corresponding flux 140 LMH) a response can be observed. This might indicate again that flocculation in the membrane plays a very important role in the removal efficiency. Since the hydraulic conditions in the membrane are not changed but the retention time in the membrane is reduced from approximately 16s to 10s, this time decrease may possibly significantly reduce micro-particle growth in the membrane. Subsequently this suggests that coagulation / flocculation before the membrane do not have a large influence on DOC removal in the configuration applied in this study. This implies that as long as enough micro-particles are formed which can grow rapidly inside the membrane channels, efficient removal will take place. This behaviour might be unique to inline flocculation with very short total retention times in the system, as applied in this study. Systems using a classical tank flocculation approach might perform different.

*Residual iron concentration.* In general, the residual iron concentrations were high for most of the operating conditions tested. For some operating conditions conducted at pH 6.5 a residual iron concentration less than 200  $\mu\text{g Fe/L}$  was measured, which is the limiting value in drinking water regulations in various countries. This parameter was therefore identified as one of the key parameters in choosing and justifying optimal operating conditions for the process combinations tested. Results from the residual iron concentrations are summarized in Figure 6.

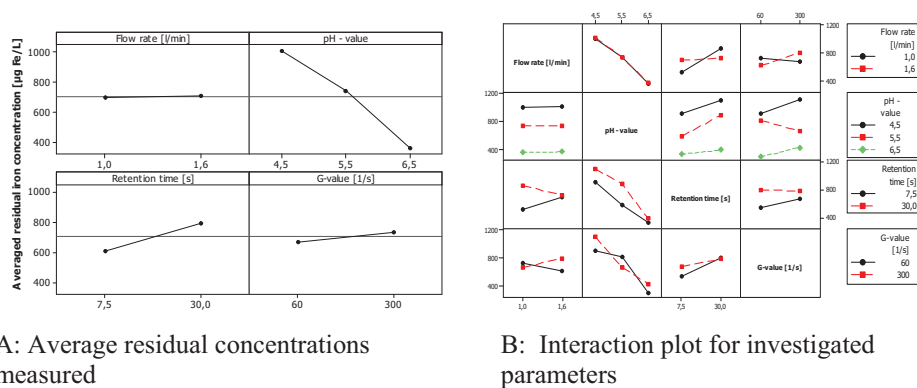

Figure 6: Overall results obtained for residual iron concentration

Solubility concentrations of metals are a function of pH, and as expected pH was found to influence the residual metal concentration for the iron based coagulant. With decreasing pH the solubility of iron increases. This is also the case in the experiments performed in this study where residual iron concentrations below 200  $\mu\text{g Fe/L}$  were only achieved at pH 6.5. Looking at the overall averaged results (Figure 6), the flow rate does not have any influence on the residual iron concentration, which is expected from a

chemical point of view where metal concentration should only be dependent on quality parameters influencing the chemical equilibrium, *i.e.* component concentration, temperature and pH.

At longer retention times of the fluid in the pipe flocculator higher residual iron concentrations were observed. From the interaction plot, influence of the residence time is biggest at the lower pH values and thus in the pH region there the metal dissolution is expected to be highest. There is also a dependence on the flow rate. At the higher flow rate no influence of the retention time is observed while at the low flow rate a low retention time of 7s promotes a low residual metal concentration and a higher retention time of 30s leads to increased metal residues. Since the flow pattern in the pipe flocculator should be the same at both flow rates due to the differently chosen pipe diameters and lengths the origin for this behaviour could be found again in the membrane. It might be possible that the differences of the retention in the membrane previously described may have an influence.

The G-value has just a minor effect. However, at a lower flow rate high G-values are benefiting low residual iron concentrations and at higher flow rates higher G-values respectively.

### Conclusions

All three compared treatment configurations showed a good and reliable process performance. DOC removal was efficient, varying from 76.2 % (inline setup) to 80.6 % (classical 2-tank setup), and with hydraulic retention times in the flocculation varying from 45 seconds to 20 minutes. A more detailed study was conducted for the inline setup as this configuration showed the potential of being simpler, less time consuming and therefore more energy efficient. Dependence on different pH-values, hydraulic retention times and G-values in the flocculator was investigated with respect to process performance. Up to 63% DOC removal was achieved and membrane fouling was controllable as a function of the operating conditions tested.

DOC removal strongly depended on the pH-value. At the investigated pH 4.5 and 5.5 the removal was greater than at 6.5. However, the residual iron concentration increased similarly making it impractical to operate at these conditions to meet regulation standards (200 µg Fe/L). The residual metal concentration was therefore identified as a key limiting parameter in the design and operation of the tested inline flocculation configuration. Compliance to the residual metal concentration was only achieved at pH 6.5. This problem can probably be solved or reduced by further improvement of the initial mixing conditions. In this study the membrane feed pump was used as initial mixing for coagulant dosing and pH adjustment. An assessment of improved mixing devices is therefore a task for future studies.

A sustainable operation of the process was only achieved for the lower flux (140 LMH) investigated in the process combination applied in this study. The higher flux (220 LMH) gave relative quick and severe membrane fouling, and only minor influence on the membrane fouling was observed for varying G-value and HRT in the pipe flocculator. The amount of reversible fouling strongly depended on the pH. At lower pH almost no reversible fouling was found, whereas at higher pH it was more obvious. Further studies are required to determine the practical operating range and to optimise the process configuration.

#### **Acknowledgements**

The authors would like to thank Metawater, Japan, for providing the filtration pilot plant and the ceramic membranes. S::can Messtechnik GmbH, Austria, is acknowledged for providing the spectrometric probe. Furthermore, the Norwegian Research Council and TECHNEAU are acknowledged for their financial support.

#### **References**

- Forsberg C. (1992). Will an Increased Greenhouse Impact in Fennoscandia Give Rise to More Humic and Colored Lakes, *Hydrobiologia*, 229, 51-58
- Hongve D., Riise G. and Kristiansen J. F. (2004). Increased colour and organic acid concentrations in Norwegian forest lakes and drinking water - a result of increased precipitation? *Aquatic Sciences* 66(2), 231-238
- Huang L., and Morissey M. (1998) Fouling of membranes during microfiltration of surimi wash water: Roles of pore blocking and surface cake formation. *Journal of Membrane Science*, 144, 113-123
- Kim J.S., Akeprathumchai S. and Wickramasinghe S.R. (2001). Flocculation to enhance microfiltration. *Journal of Membrane Science*, 182, 161-172
- Lahoussine-Turcaud V., Wiesner M., Bottero J. and Mallevalle J. (1990). Coagulation pretreatment for ultrafiltration of a surface water. *Journal American Water Works Association*, 82(12), 76-81.
- Lebeau T., Lelièvre C., Buisson H., Cléret D., Van de Venter L.W. and Côte P. (1998). Immersed membrane filtration for the production of drinking water: combination with PAC for NOM and SOCs removal. *Desalination*, 117, 219-231
- Lee S., and Cho J. (2004). Comparison of ceramic and polymeric membranes for natural organic matter (NOM) removal. *Desalination*, 160(3), 223-232.

Leiknes T., Ødegaard H. and Myklebust H. (2004). Removal of natural organic matter (NOM) in drinking water treatment by coagulation–microfiltration using metal membranes. *Journal of Membrane Science*, 242, 47–55

Leiknes T., Lazarova M. and Odegaard H. (2005). Development of a hybrid ozonation biofilm-membrane filtration process for the production of drinking water. *Water Science and Technology*, 51(6-7), 241-248

Machenbach I., Leiknes T. and Ødegaard H. (2002). Coagulation/Submerged Hollow-Fibre Ultrafiltration for NOM Removal. *Proceedings Membranes in Drinking and Industrial Water Production*. Berichte aus dem IWW, 2002, 37a, 661-668.

Meyn T., Leiknes T. and Ødegaard H. (in press). Coagulation / flocculation - ceramic membrane filtration for removal of natural organic matter (NOM) under Norwegian conditions. *Water Science and Technology*, Publication in press

Peuchot M. and Ben Aïm R. (1992). Improvement of crossflow microfiltration performances with flocculation. *Journal of Membrane Science*, 68(3), 241-248.

Ratnaweera H., Gjessing E. and Oug E. (1999). Influence of physical-chemical characteristics of natural organic matter (NOM) on coagulation properties: An analysis of eight Norwegian water sources. *Water Science and Technology*, 40(9), 89-95.

Schäfer A.I., Schwicker U., Fisher M.M., Fane A.G. and Waite T.D. (2000). Microfiltration of colloids and natural organic matter. *Journal of Membrane Science*, 151-172

Weber R., Chmiel H. and Mavrov V. (2003). Characteristics and application of new ceramic nanofiltration membranes. *Desalination*, 157(1-3), 113-125.

Yonekawa, H., Tomita Y. and Watanabe Y. (2004). Behavior of micro-particles in monolith ceramic membrane filtration with pre-coagulation. *Water Science and Technology*, 50(12), 317-325

Ødegaard H., Eikebrokk B. and Storhaug R. (1999). Processes for the removal of humic substances from water - An overview based on Norwegian experiences. *Water Science and Technology*. 40(9). 37-46.

Ødegaard H., Thorsen T. and Melin E. (2000). Practical experiences from membrane filtration plants for humic substance removal. *Water Science and Technology*. 41(10-11). 33-41.

### 6.3 Publication 3

The article with the title “MS2 removal and process performance of a coagulation / flocculation ceramic microfiltration treatment scheme for production of potable water from high NOM content surface water sources”, written by Thomas Meyn, Anne König and Tor Ove Leiknes, was submitted to the Journal of the American Institute of Chemical Engineers (AIChE Journal) in November 2010 and is currently (April 2011) in the second review phase.

In this publication hygienic aspects are investigated beside removal of NOM, since a water treatment scheme has to be able to deal with such issues in practise. “Good Disinfection Practise” is currently a discussion topic in Norway in which virus removal is one relevant concern. The discussion focuses not only on disinfection technologies by themselves, but look also at a Water Treatment Plant (WTP) as a whole. In complying with a hygienic multi-barrier approach, a definition of log-credit removal for bacteria, virus and parasites at a WTP must be specified. Subsequent to that, the log removal of each treatment process in the WTP needs to be determined, where a credit of 3 log units is suggested for virus removal by coagulation coupled with low-pressure filtration.

However, microfiltration membranes are not a hygienic barrier by themselves, and only together with a pre-treatment such as coagulation can the process efficiently retain viruses. This retention strongly depends on the operating conditions. In this study the performance of aluminium and iron based coagulants has been investigated, in dependence on dosage and pH, but also on the coagulation / flocculation setup. This investigation was done with raw water having a high natural organic matter content, expecting that this might influence the removal performance. Virus removal was monitored and coupled to all relevant treatment parameters, such as DOC and colour removal and the residual metal concentration in the membrane permeate. This makes this study quite unique compared to previously published studies on virus removal with membrane filtration.





**MS2 removal and process performance of a coagulation / flocculation ceramic microfiltration treatment scheme for production of potable water from high NOM content surface water sources**

**Thomas Mevn<sup>\*</sup>, Anne König<sup>\*\*</sup> and Tor Ove Leiknes<sup>\*</sup>**

<sup>\*</sup>Norwegian University of Science and Technology, Department of Hydraulic and Environmental Engineering, S.P. Andersensvei 5, N-7491 Trondheim, Norway

<sup>\*\*</sup>Technical University of Berlin, Department of Environmental Engineering, Berlin, Germany

E-mail: [thomas.meyn@ntnu.no](mailto:thomas.meyn@ntnu.no), [anne.koenig@tu-berlin.de](mailto:anne.koenig@tu-berlin.de), [torove.leiknes@ntnu.no](mailto:torove.leiknes@ntnu.no)

**Abstract** MS2 bacteriophages removal from surface water, characterized by high natural organic matter (NOM) content, was investigated by inline coagulation/flocculation pre-treatment followed by ceramic microfiltration (MF). Two coagulants were compared at different pH-values and dosages, with different pre-treatment configurations. MS2 and DOC removal showed similar behaviour. It increased with lower pH and higher coagulant dose. Lowering the coagulant pH from 6.5 to 5.5 for polyaluminium chloride (PACl) and to 5.0 for iron chloride (FeCl) respectively, along with doubling of the coagulant dose from 2 to 4 mg Al/L and from 4 to 8 mg Fe/L respectively, maximized the virus removal, resulting in more than 6 log unit reduction up to complete virus retention. However, at low pH the residual metal concentrations in the permeate were significantly higher than maximum levels set by drinking water standards. Comparison of a conventional coagulation pre-treatment, including rapid and slow mixing tanks (HRT 20min), to simple inline coagulation (40s HRT) did not show any significant differences in performance. High log removal values for viruses accomplished with very low dosages as reported in the literature were not achievable in this study. 2 to 4 times higher coagulant dosages were necessary since the high NOM concentration in the feed water diminishes free coagulant and directly competes with the virus particles. Special attention was further paid on the virus inactivation by metal coagulants, since contradicting results have been found in the literature. Both coagulants showed virus inactivation of a little less than 2 log units after 60 minutes contact time, which is equivalent to a virus inactivation of 99%. This inactivation was only reversible to a small extend by chemical or physical floc destruction. It was further assessed that the process combination can comply with modern hygienic barrier standards.

**Keywords** MS2; virus removal; virus inactivation; ceramic membranes; microfiltration; NOM

### **Introduction**

Water hygiene is of great concern in the production of potable water, where enteric pathogens in drinking water can cause diseases, acute infections and are able to survive for long term in the environment (Sakoda et al., 1997; Herath et al., 1999). Several cases where bacteria and viruses have caused serious outbreaks in the past have been documented (Scandura and Sobsey, 1997; Wiedenmann et al., 2001). Although enteric pathogens rarely debilitate healthy adults seriously, they can be critical for the health of young children and elderly who often have compromised immune systems (Theron and Cloete, 2002). Due to their low infection dose and low removal efficacy in conventional treatment processes, enteric viruses represent a particular health risk and their removal is a great challenge in the area of drinking water treatment technologies.

Furthermore, the removal of Natural Organic Matter (NOM) is an increasing problem in the field of water purification. Especially in Nordic countries such as Norway, where the sources of potable water – mostly surface water – contain high amounts of NOM due to the natural conditions. The literature shows, that during the last two decades the NOM concentration of lakes especially in south-eastern Norway and southern Sweden increased dramatically and unprecedentedly (Hongve et al., 2004). These natural water compounds are not harmful by themselves but can be of aesthetic concerns regarding taste and odour. Furthermore, natural organic substances appear to be precursors for disinfection by-product (DBP) formation, such as THMs (trihalomethanes), which are known as to be carcinogenic. Therefore, specific limiting values are defined in the national drinking water guidelines and the NOM removal is a major target of water research in those countries (Leiknes et al., 2004).

Efficient techniques for NOM removal can be coagulation/flocculation combined with sedimentation or filtration, ion exchange, ozonation/biofiltration and nanofiltration (Ødegaard et al., 2010). For pathogen removal or inactivation the combination of coagulation/flocculation and sedimentation/filtration methods as well as the application of reverse osmosis, nanofiltration and partially ultrafiltration are assumed to be satisfactory, especially if these techniques are complemented with disinfection methods such as UV-radiation or chlorination. Although these treatment methods have proved to be fairly effective against NOM and viruses, they still show operational or economical disadvantages (LeChevallier and Au, 2004). Granular media filtration for example which is widely used in drinking water treatment removes viruses and protozoan pathogens only efficiently if operated under optimal coagulation conditions. Nanofiltration and reverse osmosis are usually only operable at relatively high pressures at relatively low fluxes with a high chemical demand. The combination of coagulation/flocculation prior to MF may be favoured as an alternative treatment process for production of high quality potable water targeting both NOM and pathogens, since it merges all the benefits of direct coagulation and the membrane

filtration technology (Matsui et al., 2003a; Zhu et al., 2005; Fiksdal and Leiknes, 2006; Matsushita et al., 2006; Meyn and Leiknes, 2010). However, virus and NOM removal by MF only is rather poor. Furthermore, all membrane processes are prone to fouling, which refers to the blockage of membrane pores during filtration caused by the combination of sieving and adsorption of particulates and compounds onto the membrane surface or within the membrane pores. Coagulation pre-treatment is therefore necessary, since it is both reducing the membrane fouling by NOM adsorption and increases virus and NOM removal drastically. However, the coagulation has to be optimised since it otherwise increases the membrane fouling and causes other problems such as high residual metal concentrations. If optimisation is done, ceramic MF can be operated with significantly higher fluxes and higher investment costs compared to their polymeric counterparts can be balanced off (Meyn et al., 2010).

Only few studies have investigated the simultaneous elimination of NOM and viruses by coagulation/flocculation and MF treatment. However, this is fundamental for the realization of modern multiple barrier concepts, which are connecting different consecutive treatment steps in a way that even with a breakdown of one stage, a sufficient pathogen removal is still ensured (World Health Organization, 2006). However, such treatment steps are directly influencing each other. Insufficient NOM removal increases for example the chlorine demand and leads to more DBP formation. Inadequate virus removal by the MF has to be balanced by a more efficient final disinfection step. Higher coagulant dosages may be necessary in order to ensure enhanced coagulation and sufficient DBP precursor removal if the NOM content is high in the raw water. Efficient virus removal has been documented by coagulation and subsequent ceramic MF (Matsui et al., 2003a; Matsushita et al., 2005; Matsushita et al., 2006), but no or only little NOM was present. However, such investigations are important since NOM hampers the virus removal by coagulation (Gerba, 1984) and consequently compromises the hygienic barrier potential of the treatment scheme. This may be especially important for the treatment of Nordic waters compared to other surface waters, since due to their low turbidity viruses will be associated to particles to lesser degree and thus more difficult to remove. Furthermore, no direct comparison of aluminium and iron based coagulants have been published for full scale systems and similar membranes. Only few bench scale experiments with organic membranes using iron based coagulants are reported (Zhu et al., 2005). Besides virus removal, virus inactivation by aluminium and iron based coagulants is another important issue, since it is a vital difference if viruses are just inactivated by the coagulant, physically removed by the membrane or both. Furthermore a possible inactivation by metal coagulants may lead to overestimation of virus removal and thus to faulty conclusions. Results of relevant studies investigating this issue do not correspond to each other. Matsui et al. (Matsui et al., 2003b) showed a bit more than 2 log units of virus inactivation after 60 minutes by a PACl dosage of 1 mg AL/L in ultrapure water. In contrast, Zhu et al. (Zhu

et al., 2005) found no statistical relevant virus inactivation after 3.5 h hours contact time after applying iron chloride and alum. Consequently, this study was undertaken in order to address these issues. Combined virus and NOM removal was investigated at a full-scale pilot plant, in dependence on four main process parameters: coagulant type (Al and Fe based) and dose, coagulation pH and pre-treatment setup. Besides, virus inactivation was examined in jar tests, also looking at a potential reversal of a potential inactivation.

As evaluation criterion for sufficient virus removal the requirements of the Surface Water Treatment Rule (SWTR) formulated by the United States the EPA in 2001 were used (United States Environmental Protection Agency, 2001). There, virus removal or inactivation of 99.99% is demanded. Results were also evaluated with regards to recommendations published by the Norwegian national association of water and wastewater works (Ødegaard et al., 2009). There, the log credit suggested for coagulation / membrane filtration (MF/UF) is 3-log units for bacteria, viruses and parasites.

### Methods

*Raw water.* The raw water used in this study was prepared using a NOM concentrate from a full scale ion exchange treatment plant, which was mixed with tap water to make up an analogue water with a turbidity of around 1 NTU, a colour of  $30 \pm 1$  mg Pt/L at pH 7 (corresponding to an absorbance of  $1.1 \pm 0.08$  m<sup>-1</sup> at a wavelength of 436 nm), a UV<sub>254</sub>-absorbance of  $18.1 \pm 0.2$  m<sup>-1</sup> and a DOC concentration of  $4.2 \pm 0.1$  mg/L. Analogue feed water ensures that the same experimental conditions apply for all experiments conducted. Previous studies have shown that this method can be successfully used and simulates real conditions quite well (Machenbach, 2007). The NOM concentrate has been characterised as humic acid like and highly hydrophobic (Meyn and Leiknes, 2010), further having a specific UV absorption (SUVA) of  $4.3$  m<sup>-1</sup>·L/mg C.

*Pilot plant setup.* Experiments were done with a membrane filtration pilot plant using an inline coagulation/flocculation pre-treatment configuration, shown in Figure 1a). Prior to the membrane filtration unit, acid and coagulant were dosed followed by rapid mixing in the membrane feed pump, followed by a pipe flocculator with a hydraulic retention time (HRT) of 40 seconds and a G-value of around  $500$  s<sup>-1</sup>. After that, the coagulated water was filtered by the membrane unit. A second option using a two tank coagulation/flocculation setup with rapid mixing at a G-value of  $400$  s<sup>-1</sup> for 6 minutes followed by a slow mixing step with a G-value of  $100$  s<sup>-1</sup> and a retention time of 14 minutes was also investigated as an alternative to the inline configuration. The tank setup is shown in Figure 1b).

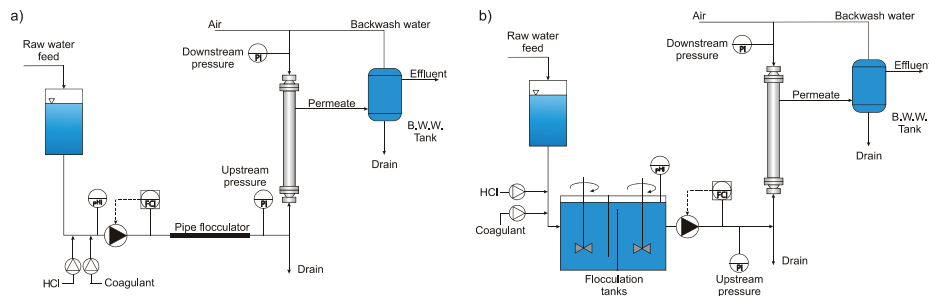

Figure 1: Flow diagram of the different membrane filtration plant configurations: a) Inline coagulation setup, b) Tank coagulation setup

In this study multi-channel ceramic membranes, operated in dead-end, inside-out mode with a nominal pore size of  $0.1 \mu\text{m}$  were investigated. The membrane flux was constant at  $143 \text{ L}\cdot\text{m}^{-2}\cdot\text{h}^{-1}$ . Each membrane module had 55 channels, was 1 m long and had an effective surface area of  $0.43 \text{ m}^2$ . The feed water was pumped in up-flow. Since only short time experiments (60 min) were performed no backwash was carried out during a test. After each experiment the membrane modules were intensively cleaned by soaking them, alternating in citric acid solution ( $w = 1 \%$ ) and sodium hypochlorite solution ( $c = 3,000 \text{ ppm}$ ). The pilot plant was equipped with two identical and independent process trains, allowing direct comparison of results. Each experiment was repeated twice with alternating the process train for statistical reasons.

*Experimental conditions.* First, two different coagulants at two dosages and pH-values were compared, polyaluminum chloride (PACl, PAX-18) and iron chloride (FeCl, PIX-111) from Kemira Chemicals AS, Norway. Both coagulants were dosed roughly at the same molar concentrations. For PAX-18 the selected dosages were 2 and 4 mg Al/L (0.074 and 0.148 mM Al/L) at pH-values of 5.5 and 6.5, for PIX-111 the investigated dosages were 4 and 8 mg Fe/L (0.071 and 0.143 mM Fe/L) at pH-values of 5.0 and 6.5. The chosen pH-values are a little lower than average commonly applied since NOM removal should be facilitated. The lower pH was chosen for FeCl compared to PACl, since optimal NOM removal takes place at different pH-values for both coagulants (Meyn and Leiknes, 2010). Based on the results from this study, the best conditions for NOM and virus removal were selected for both coagulants and applied in an additional experiment, comparing the alternative process configurations, *i.e.* inline coagulation and tank coagulation. Figure 2 shows a summary of the experimental conditions. pH-adjustment was carried out with hydrochloric acid.

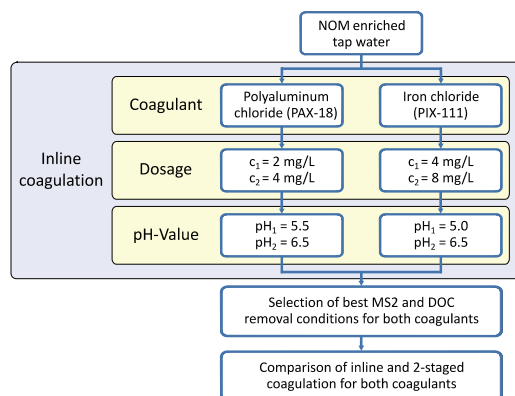

Figure 2: Flow chart of the conducted experimental series

*Microorganisms.* In this study MS2 bacteriophages (ATCC 15597-B1, LGC Standards, Sweden) were chosen for the experiments, since it is commonly used as model virus due to its similarity in size, shape, structure and nucleic acid makeup as other water-related pathogenic viruses such as poliovirus and hepatitis A virus. Furthermore, it is harmless for the human body and the assay method is fairly easy (Sakoda et al., 1997). MS2 viruses have an icosahedral structure with a diameter of around 27 nm and an isoelectric point of 3.5 (Michen and Graule, 2010). They infect gram negative male *E. coli* cells by attaching on the pili and injecting their ssRNA (Valegard et al., 1990).

For the preparation of the MS2 stock solution 25 ml of Tryptone-yeast extract-glucose broth (TYGB) were inoculated with 0.25 ml of cultured *Escherichia coli* C3000 (ATCC 15597, LGC Standards, Sweden) and incubated for 20 h at  $37\text{ }^{\circ}\text{C} \pm 2\text{ }^{\circ}\text{C}$  while shaking. From that culture, 0.25 ml were taken and transferred into 25 ml of fresh TYGB, followed by incubation for 90 min while shaking. After that, 0.1 ml of a MS2 working solution was added and the culture incubated for another 5 h while shaking. Next, 2.5 ml chloroform was added. After well mixing, the culture was cooled down to  $5\text{ }^{\circ}\text{C}$  and the water phase was separated by decantation and centrifuged for 21 min at 4800 rpm at a temperature of  $5\text{ }^{\circ}\text{C}$ , in order to purify the viruses in the culture solution from *E. coli* debris. After that, the supernatant was decanted into a sterile bottle and stored at  $5\text{ }^{\circ}\text{C}$  until use. The stock solution had an MS2 average concentration of  $1 \cdot 10^{11}$  pfu/ml.

Before the experiment the stock solution was spiked into the reservoir tank containing the NOM enriched raw water, resulting in a virus concentration in the range of  $2 \cdot 10^7$  to  $1 \cdot 10^8$  pfu/ml in the feedwater. The pilot plant was started immediately after feedwater preparation and permeate samples were taken after 20, 35 and 50 minutes. The samples were stored at  $4 \pm 2\text{ }^{\circ}\text{C}$  until assaying within 4 h. The virus concentration was determined by counting plaque forming units (pfu) after a modified overlay agar method

detailed described in NS-EN ISO 10705-1 from 2001, using *Escherichia coli* C3000 as host bacterium. This method has a detection limit of 1 pfu/ml. Only infective and viable viral particles are detectable. Inactivated viruses cannot be quantified directly. Another disadvantage of the method is that coagulated virus particles are counted as one and hence overestimation of virus removal might be a consequence (Matsui et al., 2003b). To avoid this problem, the samples were vortexed and rapidly diluted for further analysis. After each experiment the pilot plant was disinfected by adding sodium hypochlorite to the water, giving a concentration of free chlorine of 50 mg/L, and operating it for 60 minutes. After that, the plant was operated with tap water for 6 hours in order to rinse out the disinfection solution. The virus removal results are stated as Log Reduction Value (LRV) which is calculated according to equation (1), where  $c$  is the virus concentration in pfu/ml.

$$LRV = \log \frac{c_{raw\ water}}{c_{permeate}} \quad (1)$$

The concentration of MS2 bacteriophages in the NOM enriched raw water was found to be stable. At the beginning of the experimental series the virus concentrations were measured directly after spiking into the raw water and again after 50 minutes. No significant difference was found. MS2 bacteriophages are reported to be generally very stable. Yates et al. (1985) found a decay rate of MS2 viruses of  $0.068 \pm 0.04$  log pfu/day in nine different ground waters.

*Inactivation tests.* The aim of this study was also to quantify the virus inactivation after application of metal based coagulants as contradicting results are found in the literature. Inactivation is defined in this study as the inability of a virus to infect a host. It was not differentiated between reasons for this inability. The viruses may still be completely intact and just adsorbed to or entrapped in flocs created after coagulant addition, rather than really decomposed, but they are not infective for the host anymore. Furthermore, a possible virus reactivation was investigated. In opposition to inactivation, reactivation implies in this context the possibility that inactivated and thus just adsorbed viruses are reactivated or desorbed again after physical or chemical measures.

The inactivation tests were performed in a jar flocculator manufactured by Kemira Chemicals AS, Norway, and coagulant dose and pH were the same as found for optimal virus and NOM removal in this study. The virus concentration in the raw water was equal to or higher than  $3 \cdot 10^7$  pfu/ml. First acid and coagulant were dosed, followed by rapid mixing at 200 rpm for one minute followed by mixing at 20 rpm for 60 minutes. Samples were taken after 5, 15, 30 and 60 minutes. As a reference, parallel jar tests were conducted without the addition of coagulant. Samples were taken after 0 and 60 minutes and the virus log reduction measured.



Additional jar tests were performed to investigate a possible reactivation effect after viruses were inactivated by coagulation. After performing the jar tests as described above the samples were either treated with additional shear force or the pH was increased to 10. These measures should cause floc breakage or dissolving, resulting in a possible virus desorption and thus reactivation. In the case of additional shear force, the samples were vortexed after taking a sample for 5 minutes and analysed quickly after in order to avoid the reaggregation of particles. For the pH adjustment to 10, sodium hydroxide solution was added to the samples after taking. Besides variation of the vortexing time and the pH, the virus concentration was determined as described previously for the pilot plant trials. Samples were taken after 0 and 60 minutes. All experiments were also carried out without coagulant addition. This ensured that neither extended vortexing nor the pH increase up to 10 by themselves did influence the virus viability. No significant influence of these conditions was found.

*Experimental analysis.* Turbidity measurements (90° scattered light method, Turbidimeter 2100N, Hach) and the residual metal concentration (measured by High Resolution ICP-MS at the Institute for Chemistry at NTNU) in the permeate were analysed for each sample. The removal of NOM was monitored by measuring colour, UV-absorption at 254 and 436 nm (Spectrophotometer U-3000, Hitachi) and DOC (Laboratory analyser: Dohrmann Apollo 9000, Teledyne-Tekmar; Online spectrometric probe: Spectro::lyser™, s::can Meßtechnik GmbH, Vienna, Austria).

### **Results and discussion**

*MS2 removal without membrane or coagulation.* It is known that viruses may interact with charged surfaces. Therefore experiments were carried out to investigate any losses of viruses due to adsorption taking place in the pilot plant system or inside the membrane module itself. Spiked raw water was treated without and with a membrane module inserted in the pilot plant. Only the pH-value was adjusted. Without the membrane module no viruses are removed or inactivated over time at all. This indicates that the adsorption of MS2 bacteriophages onto material surfaces in the pilot plant setup (such as synthetic tubes and metallic valves or connections) during an experiment is negligible. Furthermore, no virus damage due to installed fixtures such as pumps, tube constrictions or valves was observed. However, with the MF membrane inserted an increasing removal over time up to 1 log unit was observed. This removal might be due to direct adsorption onto the membrane surface or to particles contained in the raw water. Virus adsorption to ceramic material is strongly influenced by the type material used (Wegmann et al., 2008). In general, electropositive ceramic materials show improved virus adsorption capacity since the MS2 viruses are negatively charged at pH values above the isoelectric point (IEP) and thus the virus adsorption can be very high. Furthermore, interactions between NOM and the viruses prior to the coagulation step should be considered, since viruses in water can adsorb charged species of either sign



such as NOM. This specific adsorption may alter the surface charge of a virus (Michen and Graule, 2010). Thus, the IEP of MS2 is likely to be changed due to the presence of NOM. Gerba (1984) reported that viruses and NOM contain hydrophobic groups on their surfaces and thus can attach to each other by hydrophobic interactions. Formed NOM-virus complexes may be large enough to be retained by the membrane, independent from the actual adsorption mechanism.

The removal increase over time could be explained by the formation of a thin cake layer on the membrane surface, promoting more virus retention due to adsorption or straining. NOM could form aggregates with multivalent ions found in the tap water which can be retained by the membrane. Pore constriction due to adsorbing NOM or viruses might also play a role. Such conclusions are supported by an immediate beginning of TMP increase after the start of filtration together with increased NOM removal over time, which have been observed in other pilot experiments without coagulant and virus addition. Theoretically, physical removal by itself should not be a dominant removal mechanism since the nominal membrane pore size of 100 nm is significantly larger than the virus size of 27 nm. These results correspond well to findings reported with other MF membranes. Madaeni et al. (1995), Jacangelo et al. (1995) and Zhu et al. (2005) showed MS2 removals of 0.2 to 2 log magnitudes. Fiksdal and Leiknes (2006) stated no MS2 removal by a PES-MF membrane without coagulation. Subsequently, only filtration with the ceramic MF membranes without coagulation does not fulfil any requirements for being considered a hygienic barrier.

*Effect of coagulant dosage and pH-value on MS2 removal.* Within this experimental series the effect of coagulant type, dosage and pH-value on virus removal with an inline coagulation setup was compared. Figure 3 summarizes virus removal for PACl and Figure 4 for FeCl respectively. For both coagulants the MS2 removal increased with a lower pH-value and a higher dose. For PACl these changes are especially apparent. At a pH of 6.5 only 0.8 log units are removed at an Al dose of 2 mg/L, compared to 3.0 to 3.8 log units at the same pH but for a higher dose of 4 mg Al/L. Decreasing pH to 5.5 improved the MS2 removal even more. Around 4.5 to 5.2 log units were removed with a dosage of 2 mg Al/L while almost all viruses are removed at 4 mg/L Al, where the virus concentration in the sample taken after 20 minutes was found to be below 1 pfu/ml (indicated with an arrow on top of the data bar as seen in Figure 3a)). Even though the removal performance differs by two log units at a pH of 5.5 the absolute percentage removal varies only in the third decimal place. At least 99.99% of viruses are removed. At the lower investigated pH values, coagulation hydrolysis reactions form more positively charged polynuclear species. These can efficiently react with the negatively charged virus particles and thus alleviate virus removal. Furthermore, the coagulation pH is closer to the isoelectric point of the virus particles, resulting in a reduction of the total negative charge followed by a probable reduction of electrostatic repulsion forces.

However, the pH values investigated in this study are not low enough to be close to the isoelectric point of the virus particles (Langlet et al., 2008). As a consequence, the MS2 viruses have a negative electrophoretic mobility under all investigated conditions and can thus readily react with positively charged coagulant.

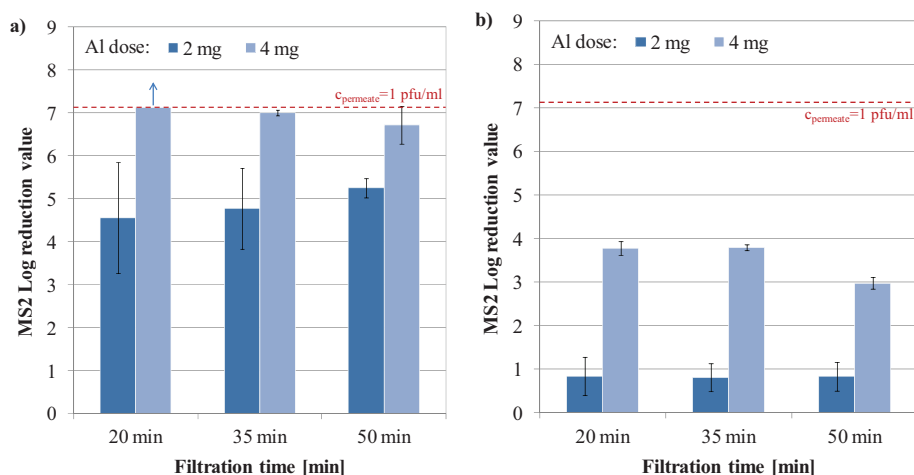

Figure 3: MS2 removal by inline coagulation with PACl as a function of coagulant dose and pH a) pH 5.5 b) pH 6.5

High MS2 removal from waters having a low DOC was reported at relatively low coagulant dosages, applying inline coagulation and similar membranes as used in this study (Matsui et al., 2003a; Matsushita et al., 2005). A >6-log removal of viruses from spiked river water (DOC  $\approx 1 \text{ mg/L}$ ) was achieved by two types of  $0.1\text{-}\mu\text{m}$  pore size ceramic MF systems with  $0.5$  to  $1.0 \text{ mg Al/l}$  of polyaluminium chloride. Shirasaki et al. (2009) confirmed these findings by showing up to 6-log reduction of MS2 bacteriophages by using inline coagulation at pH 6.8 with a PACl dosage of  $1.08 \text{ mg Al/L}$ . In this study, however, sufficient virus removal was only achievable by comparably higher coagulant dosages. This is probably due to the higher organic content in the raw water and thus higher competition between negatively charged virus and NOM particles for free binding sites on the positively charged coagulation hydrolysis products (Gerba, 1984). Virus attachment is thereby reduced and higher coagulant dosages are therefore necessary to achieve satisfactory virus and NOM removal. The virus removal may be further influenced by specific adsorption of NOM to the viruses as described earlier. The MS2 removal rates found in this study are depending on the conditions 2 to 3 times higher than results presented in a study by Hendricks et al. (Hendricks et al., 2005), where coagulation, flocculation and rapid media filtration were used with  $2.5 \text{ mg Al/l}$  dosed as alum at unknown coagulation pH, or a study by Bell et al. (Bell et al., 2002), comparing results from 9 WTP's using optimized coagulation with PACl followed by flocculation and sedimentation.

FeCl showed a similar trend as PACl. However, the differences in MS2 removal for the conditions tested were smaller (Figure 4). Lowest removals with 3.2 to 3.8 log units were found at a pH of 6.5 and an iron dose of 4 mg/L. Removal maximum was observed at a pH of 5.0 and a dose of 8 mg Fe/L, with a MS2 removal of 5.3 to 6.2 log units. Zhu et al. (2005) reported a >4-log removal of viruses at pH 6.3 with 10 mg Fe/L of ferric chloride and 0.22  $\mu\text{m}$  nominal pore size using a PVDF MF membrane. That is lower than the 5-log removal at pH 6.5 and a dosage of 8 mg Fe/L achieved in this study. Virus removal might be handicapped by 120 mg/L silica dosed into the raw water by Zhu et al., which is negatively charged like the virus particles and therefore competes for positively charged coagulant binding sites as described earlier in this section.

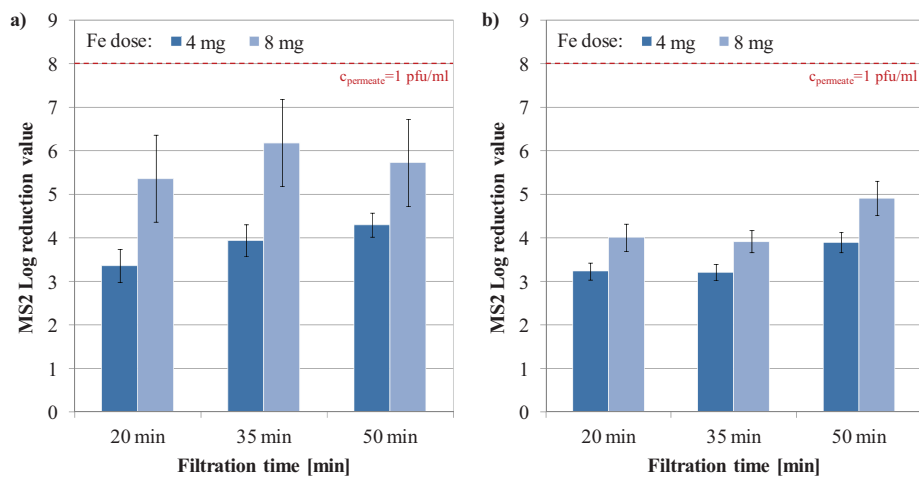

Figure 4: MS2 removal by inline coagulation with FeCl as a function of coagulant dose and pH a) pH 5.0 b) pH 6.5

Even though the removal with iron chloride is more robust to condition changes, PACl appears to have a superior removal capacity at optimized conditions. However, if the two coagulants are directly compared, PACl performs better at the lower pH, while FeCl removes more viruses at the higher investigated pH. The first observation may be explained by the fact that PACl is operated close to its performance optimum for NOM removal at a pH of 5.5, which can be found in the range from 5.5 to 6.0 (Meyn and Leiknes, 2010), while FeCl was operated at a pH of 5.0 and thus further away from its performance optimum, which is found at pH values around 4.5 and below. At a pH of 6.5 FeCl performs better, especially at the lower investigated coagulant dosage. There, the virus removal with PACl collapsed to an average of 0.8 log units, while it was xsimilar for the higher investigated coagulant dosage. The PACl dosage of 2 mg Al/L may be in the range of a minimum effective dosage for the given NOM and virus concentrations. At such dosage coagulation is possibly incomplete. However, at a

similar molar dosage, FeCl is still performing well. This may indicate a different coagulation mechanism for both coagulants, where FeCl is still active at lower concentrations. This phenomenon has not been further investigated in this study.

It could be generally assumed that at the given experimental conditions PACl has an advantage compared to FeCl since it is pre-polymerised. Thus, the active poly-aluminium species are readily available and no extensive hydrolysis reactions are necessary, as it is the case for FeCl. Coagulation takes place almost instantly for PACl, as shown for NOM removal by Meyn et al. (2010). Extending the flocculation time starting from 10 s did not significantly improve the removal in that study. It is believed that the coagulation of viruses follows the same principle. This may be especially important since the hydraulic retention time in the pipe flocculator is with 40 s very short. At such conditions no extensive floc growth is possible. However, aggregates formed are big enough in order to be retained by the membrane. Non-polymerised coagulants may need more time for their coagulation reactions and the following floc growth (Gregory and Dupont, 2001).

The infective virus concentration in the permeate decreased slightly over time in most of the experiments, suggesting the formation of a cake layer or pore constriction by complexes consisting of NOM, virus particles and coagulation hydrolysis products enhancing virus removal. Such phenomena have been described in Jacangelo et al. (1995), where a developed kaolinite cake layer and progressed membrane fouling significantly alleviated MS2 removal. Madaeni et al. (1995) showed similar effects caused by turbidity and biomass contained in the raw water. Shirasaki et al. (2008) attributed improved virus removal to irreversible membrane fouling, which maintained virus removal higher even after hydraulic backwashing. However, the gathered data are not sufficient to explain the obtained removal increase over time sufficiently and further, more specific investigations need to be done.

At the lower pH conditions investigated for both coagulants, a removal of at least 4-log units of viruses for both tested coagulant dosages was observed, with the exception of iron chloride after 20 minutes filtration time and a dosage of 4 mg Fe/L where only 3.3 log units of viruses were removed. These conditions therefore fulfilled both the Norwegian and American requirements for consideration as hygienic barrier. At the higher coagulation pH of 6.5 only FeCl at a dosage of 8 mg Fe/L was close to achieving a 4-log reduction. FeCl at the lower dosage of 4 mg Fe/L and PACl at the higher dosage of 4 mg Al/L achieved only a 3-log reduction, which is at least equal to the 3 log-credits suggested for that process. At a low dosage and at high coagulation pH, PACl failed to comply with any guidelines with poor virus removal below 1 log.

*Effect of coagulation setup on MS2 removal.* After investigating the influence of coagulant dose and pH-value, the conditions showing the highest MS2 removal were chosen for a comparison of an inline coagulation pretreatment with a conventional tank coagulation setup. Experiments were carried out at pH 5.0 and a coagulant dose of 4 mg/L for PACl, and a pH of 5.5 together with a metal dose of 8 mg/L for FeCl. As shown in Figure 5, rapid inline coagulation with 40s flocculation time performed overall better than the conventional pre-treatment setup. The virus concentration in the permeate was below 1 pfu/L for PACl in 5 from 6 samples (indicated by an arrow in the figure). This was not the case for the samples taken after 20 minutes using the conventional setup. With FeCl a clear difference was seen between the two treatment configurations tested. Virus removal was almost complete with the inline pre-treatment, whereas it was in the range of 6 to 7 log units for the conventional setup. It should be noted that the virus removal with FeCl was 2 log units higher than observed in the experiments comparing different pH-values and coagulant dosages (Figure 4a). This is probably due to the higher virus concentration in the raw water in the first set of experiments ( $1 \cdot 10^8$  pfu/ml), compared to a concentration of  $6 \cdot 10^7$  pfu/ml in this series. Results from the comparison study show full compliance with the requirements for hygienic barriers of the coagulation/ceramic MF treatment scheme.

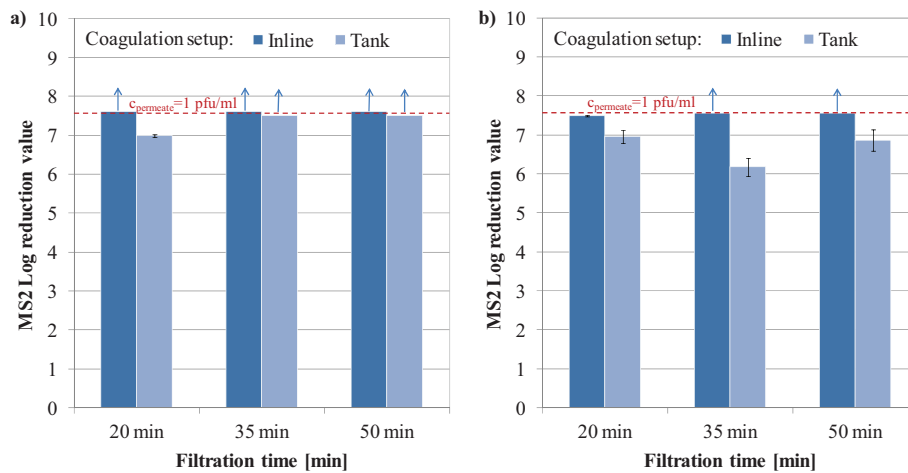

Figure 5: MS2 removal at optimized conditions in dependence on the pre-treatment setup and coagulant type: a) Polyaluminium chloride (4 mg Al/L, pH 5.5) b) Iron chloride (8 mg Fe/L, pH 5.0)

The disadvantageous performance of the conventional setup observed is probably a result of the fact that the flocs formed in the slow mixing tank are destroyed in the membrane feeding pump. This might liberate viruses to some extent and even though floc regrowth occurs, it is not as efficient in binding viruses again as the initial

coagulation process. A possible higher inactivation of viruses by metallic coagulants due to the significantly higher contact time in the conventional setup was not observed.

Nevertheless, under optimized conditions MS2 viruses are efficiently removed by both process configurations compared. With regard to a technical and economical assessment this indicates that there is no need for sophisticated pre-treatment in a coagulation/flocculation coupled with MF filtration process for producing potable water from surface waters containing high NOM concentrations. A simple inline coagulation and flocculation setup is demonstrated to ensure good virus removal if the conditions are optimized, and an enhanced coagulation time does not necessarily improve virus removal. This has been also been reported for PACl by Matsushita et al. (2005), where HRT's of 1.1, 2.4 and 60 s were investigated and an increase in time only had a minor effect on the MS2 removal. The results from this study confirm that this applies for FeCl as well.

*Virus inactivation by metal based coagulants.* In order to gain more knowledge about the inactivation by metal coagulants, jar test experiments were performed, applying again the identified optimal conditions for NOM and virus removal. Both coagulants showed an inactivation potential of 1 to 1.6 log units already after 5 minutes of contact time as shown in Figure 6a), increasing further up to almost 2 log units or 99% after 60 minutes. Inactivation potential was found to be larger with FeCl compared to PACl. However, after 60 minutes both coagulants showed almost the same inactivation potential. Control experiments without coagulant addition did not show any reduction of viable and active virus.

The up to 2 log units of inactivation found in this study correspond to the results found by Matsui et al. (2003b), who found a bit more than 2 log units of virus inactivation after 60 minutes by a PACl dosage of 1 mg AL/L in ultrapure water. They further observed a rapid inactivation at the beginning of the experiment as observed in this study, followed by reduced inactivation during the rest of the experiment. Fiksdal and Leiknes (2006) found MS2 inactivation rates of 1.0 to 1.3 log units for a PACl dose of 3 mg Al/L (coagulation pH 7.0) and 1.4 to 1.6 log units for a dose of 5 mg Al/L (coagulation pH 6.7), using a raw water based on tap water with a TOC of 2.5 mg/L and an alkalinity of 0.9 mM. In contrast, Zhu et al. (2005) showed no statistical relevant virus inactivation after 3.5 h hours contact time in an artificial raw water containing NaHCO<sub>3</sub> and CaCl<sub>2</sub> after adding iron chloride (5 and 10 mg Fe/L, pH6.3, 120 mg/L insoluble silica) and alum (1 and 5 mg Al/L, pH 7.0, no silica addition). Even though the inactivation results obtained correspond well with Matsui et al. (2003b), the coagulant dose used in this study was significantly higher but the achieved inactivation in the same range. This can be explained again by the relatively high NOM content in our raw water, causing a competition among virus particles and NOM molecules for

binding sites at hydrolyzed coagulant, a phenomenon also described by Matsui et al. (2003b). They further reported highest virucidal activity for PACl already at low dosages, possibly due to its prepolymerized character compared to other aluminium based coagulants. However, this study showed that iron chloride has at least the same if not a higher inactivation capacity.

In a second series of jar tests the reversibility potential of inactivation by FeCl was investigated. Two possible methods were examined, destruction of formed flocks by pH increase up to 10 and application of additional shear force by intensive sample vortexing. Compared to the experiments carried out according to the normal experimental protocol, without additional shear and at a pH of 5, both the introduction of additional shear and the increase of pH led to lower virus log reduction of 1.1 to 1.3 (Figure 6b). It was therefore concluded that viruses which are rendered inactive by coagulation, for example due to adsorption of coagulant or to flocs, can be desorbed to a large extent and are infective again. However, more than 90% of the viruses were still not able to infect a host anymore, in spite of the reactivation found. This finding does not imply that these inactivated viruses are surely decomposed.

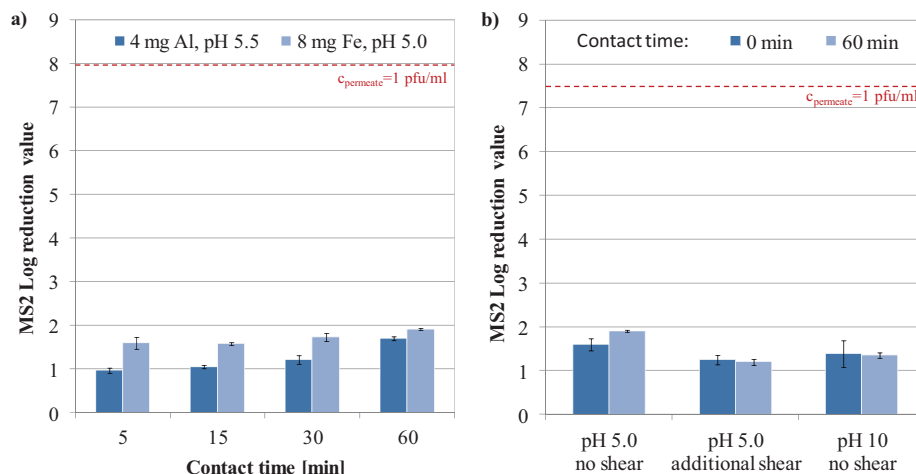

Figure 6: Inactivation of MS2 a) by PACl and FeCl at optimized coagulation conditions (n=3) b) Inactivation change by FeCl (8 mg Fe/L) in dependence on pH increase or additional shear force (n=2)

Results found in this study that both shear or pH-increase can restore virus infectivity to a small extent, do not correspond to findings of Matsui et al. (2003b), who showed no alleviated infectivity after dissolving the formed flocs by vortexing after adding an alkaline solution (sodium hydroxide + 6% beef extract) and thus increasing the pH to 9.5. However, the true inactivation mechanisms remain unclear. Different studies have

proposed that hydrolysis products adsorb to the virus surface, alter the morphology of the coat proteins and render them non-functional or shield them (Gerba, 1984; Matsui et al., 2003b; Fiksdal and Leiknes, 2006; Shirasaki et al., 2009). In this study the high NOM content in the raw water might play a role. Even though it does not show any inactivation potential by itself, it may contribute to the effect in combination with coagulant hydrolysis products.

*Organic matter removal.* Parallel to the MS2 reduction NOM removal by the inline coagulation configuration was monitored, which increased both with increased coagulant dosage and decreased pH-value for both coagulants applied. At lower pH-values positively charged metal hydrolysis products can interact with organic matter with a high negative net charge (Gregor et al., 1997). PACl removed between 47 and 66% of DOC as shown in Figure 7a), whereas DOC removal with FeCl was in the range of 43 to 70% (Figure 7b)). These rates are 5 to 10% lower than reported in Meyn and Leiknes (2010), in spite of a higher DOC concentration of 5.2 mg/L in the raw water.

Direct comparison of the two coagulants, which were applied at the same molar dosage, showed similar DOC removal rates. At pH 6.5, PACl gave a 5% better DOC removal, indicating an advantage for pre-polymerized coagulants compared to non-polymerized. However, at the lower pH tested for each coagulant, FeCl performed 3 to 6 % better compared to PACl.

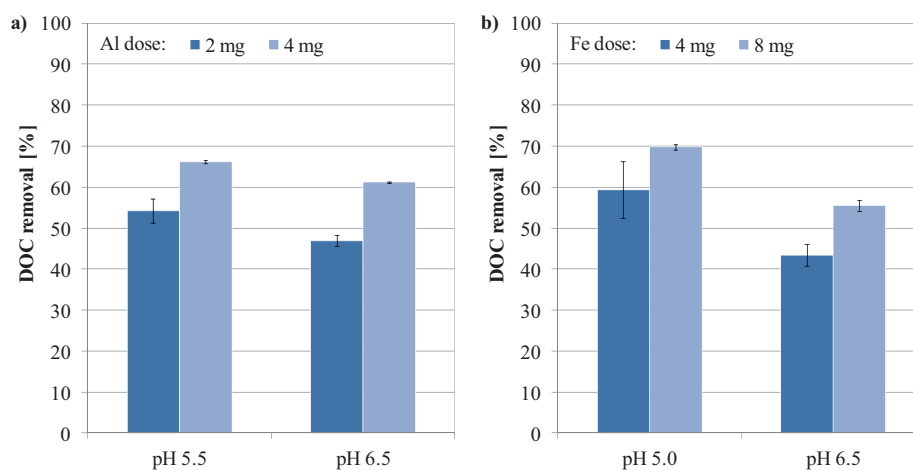

Figure 7: DOC removal with inline coagulation as a function of pH-value and coagulant dose with a) PACl and b) FeCl

Colour removal, expressed as  $VIS_{436}$  reduction, followed the same pattern as DOC removal, but with higher removal rates (Figure 8). PACl removed between 78 and 94%



whereas the removal was in the range of 73 to 96% with FeCl.  $UV_{254}$  absorption was reduced by 58 to 83% with PACl and 43 to 88% with FeCl respectively. These rates are lower than the ones observed for colour removal, but higher than the DOC removal rates. Higher molecular weight, hydrophobic NOM, containing a lot of aromatic carbon, is preferentially removed, giving the higher removal rates of  $VIS_{436}$  and  $UV_{254}$  compared to the total DOC.

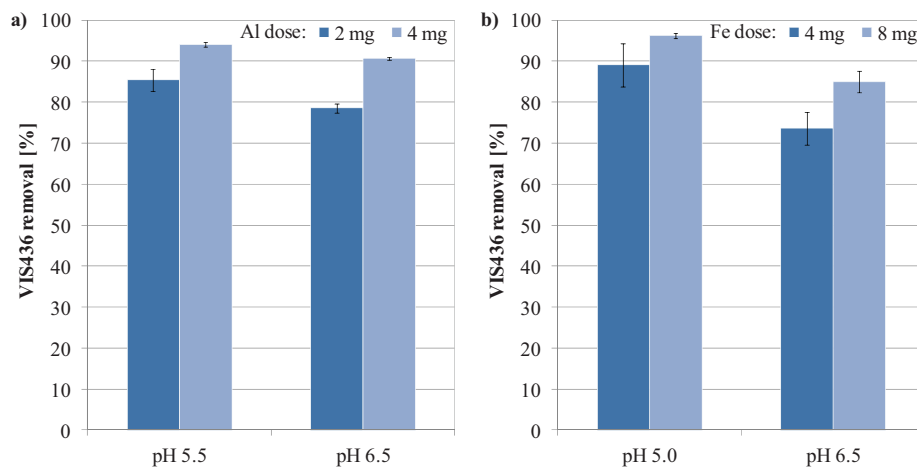

Figure 8:  $VIS_{436}$  removal with inline coagulation in dependence on pH-value and coagulant dose with a) PACl and b) FeCl

Investigations of the influence of the coagulation pre-treatment at a given pH and coagulant dose revealed that removal of NOM is independent of the process configuration. Coagulant dosing before the membrane feeding pump followed by 40s of flocculation showed the same results as 20 minutes tank coagulation/flocculation. Around 67% of DOC and 95% of colour were removed at a coagulation pH of 5.5 and a PACl dose of 4 mg Al/l, independent from the pre-treatment. For FeCl, 69% of DOC and 96% of the colour were removed at a dosage of 8 mg Fe/L and a pH of 5.0. It can be therefore concluded that already after a few seconds of flocculation time particles are created that can be efficiently retained by the membrane. However, membrane fouling was not monitored in this study, which ultimately will affect optimal operating conditions and design criteria for full-scale operation of such a treatment plant. For NOM removal, PACl and FeCl showed comparable results at the same molar dose and at optimal pH-value.

*Residual metal.* At optimal pH-values for NOM removal high residual metal concentrations were observed, where a higher coagulant dose resulted in twice as high metal residues (Figure 9). With a dosage of 2 mg Al a residual metal concentration of

98  $\mu\text{g Al/L}$  was observed and with 4 mg Al/L 204  $\mu\text{g Al}$  respectively, at coagulation pH of 5.5. Coagulation with FeCl at pH 5.0 gave residual iron concentrations of 222  $\mu\text{g/L}$  at a coagulant dose of 4 mg and up to 394  $\mu\text{g/L}$  at a dosage of 8 mg Fe/L. At a higher pH-value of 6.5, residual metal concentrations well below 150  $\mu\text{g Me/L}$ , the limiting value in the Norwegian drinking water guidelines, were accomplished with both coagulants. Based on the results presented in this study and findings from Meyn and Leiknes (2010) it can be concluded that optimal conditions for virus and NOM removal cannot be directly applied in practice since residual metal concentrations will exceed the legal threshold. Therefore, the coagulant dose has to be reduced or the pH-value increased. The minimum applicable coagulation pH to comply with residual metal concentrations, at optimized coagulant dose, is estimated to be around 6 for both tested coagulants. It should be noted that PACl produces lower residual metal concentrations compared to FeCl. This conclusion, however, is only surly valid at a coagulation pH of 6.5, where both coagulants were tested.

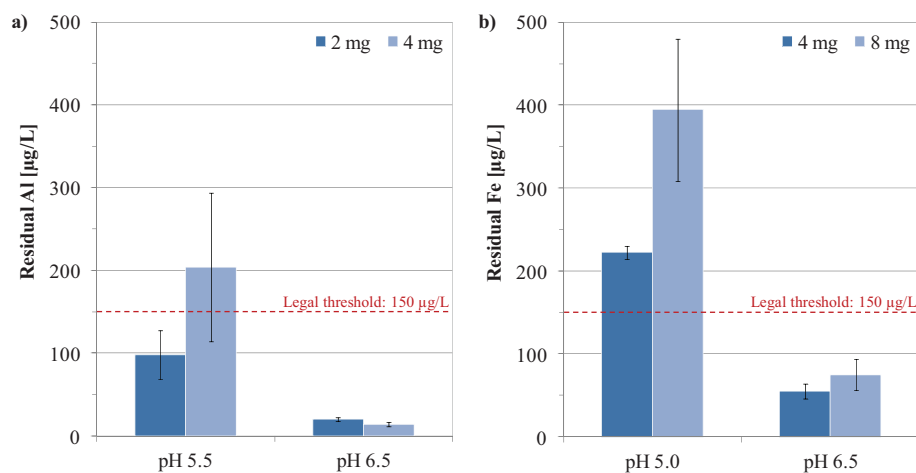

Figure 9: Residual metal concentration with inline coagulation in dependence on pH-value and coagulant dose with a) PACl and b) FeCl

Comparison of the influence of coagulation pre-treatment on the residual metal concentration at optimized conditions for virus and NOM removal revealed no significant difference for both pre-treatment setups and both coagulants. With a PACl dose of 4 mg Al/L at a coagulation pH 5.5 the residual metal concentration was found to be  $204 \pm 90 \mu\text{g Al/L}$  using the inline setup, compared to  $212 \pm 24 \mu\text{g Al/L}$  with the tank coagulation pre-treatment. At a FeCl dosage of 8 mg Fe/L,  $394 \pm 86 \mu\text{g Fe/L}$  have been found using the inline setup and  $403 \pm 46 \mu\text{g Fe/L}$  for the tank pre-treatment respectively. However, residual metal values exceeded by far the legal threshold of 150  $\mu\text{g Me/L}$  due to a low pH-value, which appears to be the major guiding value for

the residual metal concentration. Longer flocculation of up to 20 minutes as used in the conventional coagulation pre-treatment is not able to lower the metal residues in the permeate significantly.

*Overall performance.* A summary of the results from the investigations in this study are presented in Figure 10. All virus and DOC removal results are shown with respect to associated residual metal concentrations. The gray area in Figure 10 represents the target area of operation, where virus removal is higher than 4 log units (as demanded by the EPA) and the residual metal concentration is below the legal limit (as demanded by Norwegian regulations). As can be clearly seen, only two tests conditions are within this area. Several operating conditions comply with >4 log virus removal, but failed to meet residual metal limits. Applying a log 3 removal credit as suggested by the Norwegian national association of water and wastewater works for coagulation coupled with UF/MF filtration, more operating conditions comply with regulations. The results from this study can therefore be used as a starting point to set recommended operating conditions for a coagulation/flocculation pre-treatment coupled with ceramic MF filtration in practice. The coagulation pH needs to be higher than 6 in order to avoid high residual metal concentrations in the permeate. In this pH region efficient virus and DOC removal can be achieved, however, a higher coagulant dose is required.

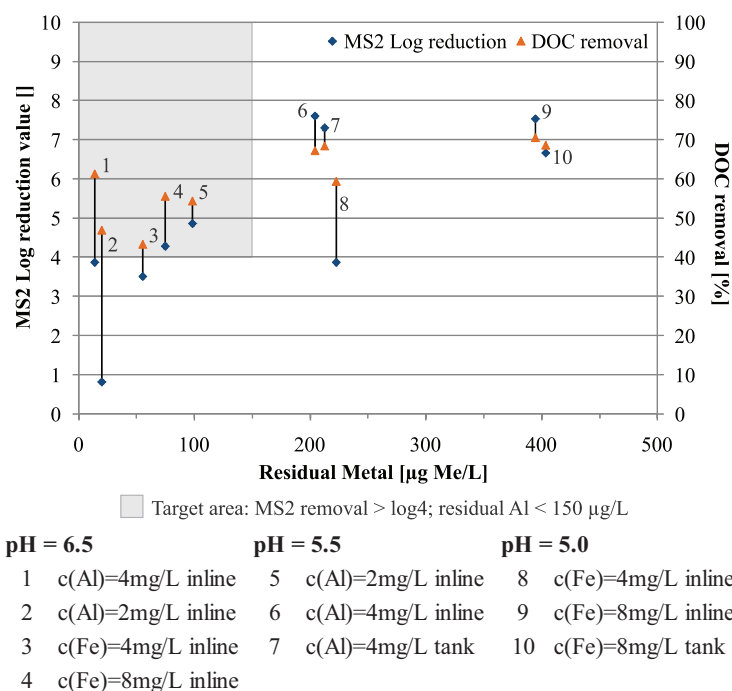

Figure 10: Overall summary of MS2 and DOC removal results

Direct comparison of virus and NOM removal indicated similar removal trends (Figure 11). It increased for both components with increased coagulant dosage and decreased pH value. High DOC removal implied also high MS2 removal. This behaviour may indicate similar coagulation mechanisms. Both, MS2 viruses and NOM molecules are negatively charged in the investigated pH range. As a consequence they can both react in a similar way with provided coagulant. Since the removal increases at lower pH, it is suggested that the reaction with positively charged metal complexes is the dominating removal mechanism for both. Thus enough coagulant has to be dosed in order to ensure efficient virus removal if waters with a high content of NOM are treated by coagulation.

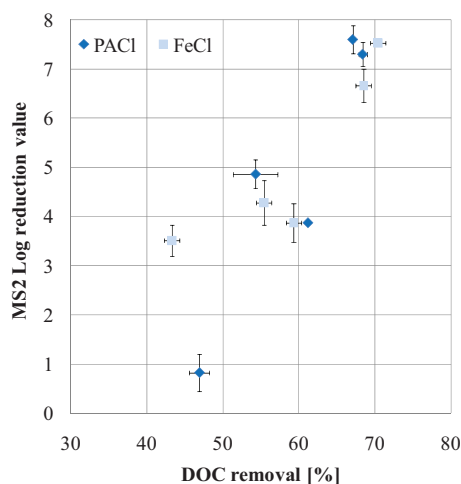

Figure 11: Direct comparison of MS2 and DOC removal

### Conclusions

While only up to 1 log unit of MS2 bacteriophages was removed by ceramic MF itself from a feed solution with high NOM content, the retention increased drastically if coagulation pre-treatment was applied. Lowering the coagulant pH from 6.5 to 5.5 for PACl and 5.0 for FeCl respectively, and doubling of the coagulant dose from 2 to 4 mg Al/L and from 4 to 8 mg Fe/L respectively, maximized the virus removal, resulting in more than 6 log unit reduction up to complete virus retention.

Comparison of an inline coagulation and rapid flocculation (45 s HRT) with a conventional rapid and slow mixing tank pre-treatment (20 min) showed a similar performance for the simpler inline process configuration. The tank coagulation/flocculation configuration, however, showed a 1 log unit less virus removal, probably due to flock destruction and virus liberation in the membrane feeding pump. The flocculation parameters pH and coagulant dose had a much more significant

influence on virus and NOM removal. Both, PACl and FeCl<sub>3</sub>, are able to efficiently remove viruses and showed a balanced performance. While FeCl<sub>3</sub> removed 1 to 2 more log units of MS2 at pH 6.5, PACl showed a slight advantage at the lower optimal pH.

In contrast to literature findings, 2 to 4 times higher coagulant dosages were necessary to accomplish similarly high virus removal rates. This was explained by the high NOM concentration in the feedwater, which like the virus particles is negatively charged at the applied coagulant pH-values and thus reacts very well with the hydrolyzed coagulant. High NOM in the raw water diminishes free coagulant and is in directed competition with the virus particles.

Virus removal was observed to improve over time for the tests done in this study. This suggests that the removal properties of the membrane change during filtration, most likely due to development of a cake layer on the membrane surface consisting of coagulated natural organic matter molecules and virus particles, or pore constriction by these substances.

Virus inactivation by metal coagulants reported in the literature was confirmed. Both applied coagulants showed virus inactivation of a little less than 2 log units after 60 minutes contact time. That is equivalent to a virus inactivation of 99%. Inactivation was observed to increase rapidly at the beginning of an experiment and continued with a reduced rate. The inactivation was only reversible to a small extent by applying a shear force or dissolving the flocks at pH 10. Infectivity was increased by 0.6 to 0.7 log units.

NOM and virus removal followed a similar pattern. It increased with increasing coagulant dose, decreasing coagulation pH, and was independent of the pre-treatment setup. Colour was preferentially removed to DOC.

At high coagulation pH, the residual metal concentration was well below the legal limit of 150 µg/L and therefore not an issue for neither of the two coagulants. At the lower pH values, found to be optimal for virus and NOM removal, the residual metal increased drastically and reached up to 4 times the legal limit in some experiments, particularly at higher coagulant dosages. The residual metal is therefore a limiting factor for selecting the conditions for operation in practice, where coagulation pH-values need to be chosen that meet required residual metal concentration in the permeate.

For compliance with legal regulations, coagulation pH-values should be set at 6 or higher to avoid high residual metal concentrations. At these pH-values efficient virus removal can still be achieved, however, higher coagulant dosages are required. By optimizing the coagulation/flocculation pre-treatment, efficient removal of NOM can be achieved while complying with hygienic barrier requirements, resulting in virus

removal of 4 log units and higher. Coagulation/flocculation pre-treatment coupled with ceramic MF filtration is thus a viable and flexible treatment scheme for the production of high quality potable water from surface waters with high NOM concentrations.

#### **Acknowledgements**

The authors would like to thank Metawater Co., Ltd., Japan for providing the filtration pilot plant and the ceramic membranes. Scan Messtechnik GmbH, Vienna, Austria, is acknowledged for providing the spectrometric probe, making an online treatment process monitoring possible. The authors would further like to thank the Norwegian Research Council and the TECHNEAU project for their financial support.

#### **References**

Bell, K., LeChevallier, M., Abbaszadegan, M., Amy, G., Sinha, S., Benjamin, M., Ibrahim, E., (2002). Enhanced and optimized coagulation for particulate and microbial removal, AWWA Research Foundation and American Water Works Association, Denver, CO, USA.

Fiksdal, L., Leiknes, T., (2006). The effect of coagulation with MF/UF membrane filtration for the removal of virus in drinking water. *Journal of Membrane Science* 279 (1-2), 364-371.

Gerba, C.P., (1984). APPLIED AND THEORETICAL ASPECTS OF VIRUS ADSORPTION TO SURFACES. *Advances in Applied Microbiology* 30, 133-168.

Gregor, J.E., Nokes, C.J., Fenton, E., (1997). Optimising natural organic matter removal from low turbidity waters by controlled pH adjustment of aluminium coagulation. *Water Research* 31 (12), 2949-2958.

Gregory, J., Dupont, V., (2001). Properties of flocs produced by water treatment coagulants. IWA Publishing, pp. 231-236.

Hendricks, D.W., Clunie, W.F., Sturbaum, G.D., Klein, D.A., Champlin, T.L., Kugrens, P., Hirsch, J., McCourt, B., Nordby, G.R., Sobsey, M.D., Hunt, D.J., Allen, M.J., (2005). Filtration removals of microorganisms and particles. *Journal of Environmental Engineering-Asce* 131 (12), 1621-1632.

Herath, G., Yamamoto, K., Urase, T., (1999). Removal of viruses by microfiltration membranes at different solution environments. *Water Science and Technology* 40 (4-5), 331-338.

Hongve, D., Riise, G., Kristiansen, J.F., (2004). Increased colour and organic acid concentrations in Norwegian forest lakes and drinking water - a result of increased precipitation? *Aquatic Sciences* 66 (2), 231-238.

Jacangelo, J.G., Adham, S.S., Laine, J.M., (1995). MECHANISM OF CRYPTOSPORIDIUM, GIARDIA, AND MS2 VIRUS REMOVAL BY MF AND UF. *Journal American Water Works Association* 87 (9), 107-121.

Langlet, J., Gaboriaud, F., Duval, J.F.L., Gantzer, C., (2008). Aggregation and surface properties of F-specific RNA phages: Implication for membrane filtration processes. *Water Research* 42 (10-11), 2769-2777.

LeChevallier, M., Au, K.K., (2004). *Water Treatment and Pathogen Control: Process efficiency in achieving safe drinking water.* The World Health Organization, IWA Publishing, London.

Leiknes, T., Ødegaard, H., Myklebust, H., (2004). Removal of natural organic matter (NOM) in drinking water treatment by coagulation-microfiltration using metal membranes. *Journal of Membrane Science* 242 (1-2), 47-55.

Machenbach, I., (2007). *Drinking Water Production by Coagulation and Membrane Filtration,* Department of Hydraulic and Environmental Engineering. Doctoral thesis, Norwegian University of Science and Technology, Trondheim.

Madaeni, S.S., Fane, A.G., Grohmann, G.S., (1995). VIRUS REMOVAL FROM WATER AND WASTE-WATER USING MEMBRANES. *Journal of Membrane Science* 102, 65-75.

Matsui, Y., Matsushita, T., Inoue, T., Yamamoto, M., Hayashi, Y., Yonekawa, H., Tsutsumi, Y., (2003a). Virus removal by ceramic membrane microfiltration with coagulation pre-treatment. *Water Science and Technology: Water Supply* 3 (5-6), 93-99.

Matsui, Y., Matsushita, T., Sakuma, S., Gojo, T., Mamiya, T., Suzuoki, H., Inoue, T., (2003b). Virus inactivation in aluminum and polyaluminum coagulation. *Environmental Science & Technology* 37 (22), 5175-5180.

Matsushita, T., Matsui, Y., Shirasaki, N., (2006). Analysing mass balance of viruses in a coagulation-ceramic microfiltration hybrid system by a combination of the polymerase chain reaction (PCR) method and the plaque forming units (PFU) method. *Water Science and Technology* 53 (7), 199-207.

Matsushita, T., Matsui, Y., Shirasaki, N., Kato, Y., (2005). Effect of membrane pore size, coagulation time, and coagulant dose on virus removal by a coagulation-ceramic microfiltration hybrid system. *Desalination* 178 (1-3), 21-26.

Meyn, T., Altmann, J., Leiknes, T., (2010). Direct surface water treatment with coagulation/ceramic microfiltration - Minimisation of flocculation pre-treatment. *Desalination and Water Treatment*. Under review.

Meyn, T., Leiknes, T.O., (2010). Comparison of optional process configurations and operating conditions for ceramic membrane MF coupled with coagulation/ flocculation pre-treatment for the removal of NOM in drinking water production. *Journal of Water Supply: Research and Technology - Aqua* 59 (2-3), 81-91.

Michen, B., Graule, T., (2010). Isoelectric points of viruses. *Journal of Applied Microbiology* 109 (2), 388-397.

Sakoda, A., Sakai, Y., Hayakawa, K., Suzuki, M., (1997). Adsorption of viruses in water environment onto solid surfaces. *Water Science and Technology* 35 (7), 107-114.

Scandura, J.E., Sobsey, M.D., (1997). Viral and bacterial contamination of groundwater from on-site sewage treatment systems. *Water Science and Technology* 35 (11-12), 141-146.

Shirasaki, N., Matsushita, T., Matsui, Y., Kobuke, M., Ohno, K., (2009). Comparison of removal performance of two surrogates for pathogenic waterborne viruses, bacteriophage Q $\beta$  and MS2, in a coagulation-ceramic microfiltration system. *Journal of Membrane Science* 326 (2), 564 - 571.

Shirasaki, N., Matsushita, T., Matsui, Y., Ohno, K., (2008). Effects of reversible and irreversible membrane fouling on virus removal by a coagulation-microfiltration system. *Journal of Water Supply Research and Technology-Aqua* 57 (7), 501-506.

Theron, J., Cloete, T.E., (2002). Emerging waterborne infections: Contributing factors, agents, and detection tools. *Critical Reviews in Microbiology* 28 (1), 1-26.

United States Environmental Protection Agency, (2001). National Primary Drinking Water Standards, EPA 816-F-01-007.

Valegard, K., Liljas, L., Fridborg, K., Unge, T., (1990). THE 3-DIMENSIONAL STRUCTURE OF THE BACTERIAL-VIRUS MS2. *Nature* 345 (6270), 36-41.



Wegmann, M., Michen, B., Graule, T., (2008). Nanostructured surface modification of microporous ceramics for efficient virus filtration. *Journal of the European Ceramic Society* 28 (8), 1603-1612.

Wiedenmann, A., Langhammer, W., Botzenhart, K., (2001). A case report of false negative Legionella test results in a chlorinated public hot water distribution system due to the lack of sodium thiosulfate in sampling bottles. *International Journal of Hygiene and Environmental Health* 204 (4), 245-249.

World Health Organization, (2006). Guidelines for drinking-water quality [electronic resource]: Incorporating 1st and 2nd addenda, Vol.1, Recommendations. – 3rd ed., Yates, M.V., Gerba, C.P., Kelley, L.M., (1985). VIRUS PERSISTENCE IN GROUNDWATER. *Applied and Environmental Microbiology* 49 (4), 778-781.

Zhu, B.T., Clifford, D.A., Chellam, S., (2005). Virus removal by iron coagulation-microfiltration. *Water Research* 39 (20), 5153-5161.

Ødegaard, H., Østerhus, S., Melin, E., (2009). Optimal desinfeksjonspraksis fase 2, 169 - 2009

Ødegaard, H., Østerhus, S., Melin, E., Eikebrokk, B., (2010). NOM removal technologies – Norwegian experiences. *Drinking Water Engineering and Science* 3 (1-9).



## 6.4 Publication 4

The following article “Direct surface water treatment with coagulation/ceramic microfiltration - Minimisation of flocculation pre-treatment”, written by Thomas Meyn, Johannes Altmann and TorOve Leiknes, was accepted for publication in *Desalination and Water Treatment* in January 2011.

This article investigates in detail the inline coagulation pre-treatment in order to obtain knowledge about how much flocculation is actually necessary, if Nordic waters are treated by coagulation - ceramic MF. For inline coagulation a static mixer was applied, followed by pipe flocculation with different retention times and mixing intensities. After evaluation of previous results, the membrane flux was increased to  $250 \text{ L m}^{-2} \text{ h}^{-1}$  in this work, since stable operation was accomplished before with lower fluxes. This was done in order to increase the challenge of the system and to investigate possible advantages of ceramic membranes compared to other treatment technologies, such as polymeric membranes.



### **Direct surface water treatment with coagulation/ceramic microfiltration - Minimisation of flocculation pre-treatment**

**Thomas Meyn<sup>\*</sup>, Johannes Altmann<sup>\*\*</sup> and TorOve Leiknes<sup>\*</sup>**

<sup>\*</sup>Norwegian University of Science and Technology, Dep. of Hydraulic and Environmental Engineering, S.P. Andersensvei 5, 7491 Trondheim, Norway (E-mail: [thomas.meyn@ntnu.no](mailto:thomas.meyn@ntnu.no))

<sup>\*\*</sup>Technical University of Berlin, Department for chemical engineering, Straße des 17. Juni 135, 10623 Berlin, Germany

**Abstract** Direct treatment of surface waters with high natural organic matter content and low turbidity by low pressure ceramic membrane filtration has emerged during the last years as an alternative to conventional water treatment systems or high pressure nanofiltration. The use of ceramic microfiltration combines high effluent water quality with regards to particle retention and microbiological aspects with a very robust treatment system, which allows high flux operation without permeability loss over time. However, pretreatment for low pressure membranes should differ significantly from pretreatment for conventional systems. Extensive flocculation can be considered as inefficient since already coagulated microparticles are efficiently retained by the membrane. Insufficient pretreatment on the other side surely leads to increased fouling. Thus, the goal of this study was to evaluate the minimum pretreatment necessary for this hybrid process with help of experimental design. An analogue surface water with a DOC of 6.8 and a colour of 55 mg Pt/L was treated by rapid inline coagulation with PACl at pH 6, followed by inline flocculation at varying conditions (coagulant dose: 2.6 and 4.4 mg Al/L, G-value: 4 to 300 s<sup>-1</sup>, retention time: 10 to 240 s), and final membrane filtration at 250 L·m<sup>-2</sup>·h<sup>-1</sup>. DOC removal was found to be up to 70 %, only depending on the coagulant dose and not on the flocculation conditions. However, the pretreatment had to be optimized in order to stabilize irreversible fouling below a rate of 1 mbar/h.

**Keywords** NOM removal; Ceramic membranes; Microfiltration; Coagulation; Surface water

#### **Introduction**

Ceramic low pressure membranes coupled with a coagulation/flocculation pre-treatment is an emerging full scale treatment alternative for drinking water production from surface waters containing high loads of organic matter and colour (Abrahamsson et al. 2007). In the past, direct filtration of NOM by NF membranes has been successfully used, however a number of disadvantages have been identified; high irreversible fouling, high operating pressures at low fluxes, permeability loss over time and high chemical demand (Ødegaard et al. 2010). With ceramic microfiltration filtration these

can be avoided to a large extent. Low pressure membranes can operate more energy efficiently, where higher investment costs for ceramic membranes can be offset by operating with significantly higher fluxes (Meyn and Leiknes 2010).

Surface waters in the northern region of Europe are typically characterised by a high content of Natural Organic Matter (NOM), resulting in high colour, very low turbidity, low alkalinity and low hardness, due to the natural conditions (Ratnaweera et al. 1999). Although the main part of NOM is not harmful, some fractions like algogenic matter can cause colour, taste and odour problems or are even toxic like the algae toxin microcystin. Special fractions of NOM in the drinking water can potentially lead to bacterial regrowth in the distribution system. Removal of NOM also reduces the load of following treatment steps and facilitates elimination of important trace compounds such as pesticides found in the NOM. Furthermore, these substances increase the necessary amount of disinfectants and are recognized as precursors for disinfection by-product formation, such as THM's which can be carcinogenic. The Norwegian Institute of Public Health has subsequently provided limiting values and recommendations in the national drinking water guidelines. The removal of NOM is therefore one of the major concerns and makes an advanced drinking water treatment necessary.

Furthermore, there is a growing concern on the increase of NOM in natural water sources, where recent studies have shown that the concentration of NOM in surface water has increased in the past and might further increase during the next decades, caused by progressing climate change issues or changed precipitation patterns. Reduced acid rain might also play a role. Due to increased precipitation in parts of Scandinavia during the last 30 years the water pathways in many catchments have changed, leading to an increased leaching of organic compounds from the upper forest floor to the lakes. In some areas a concentration increase of up to 50 % of colour and DOC between 1983 and 2000/2001 has been reported (Forsberg 1992; Hongve et al. 2004).

Pre-treatment needs are assumed to differ quite significantly for membrane filtration compared to conventional processes (i.e. rapid sand filter). However, how the membrane exactly responds to different pre-treatment such as varying flocculation conditions (flocculation time, G-value, coagulant dose), how this may impact the process and how much flocculation actually is necessary, has not been studied in detail so far. Various pilot studies have therefore been done on a pilot plant containing three parallel process trains, allowing direct comparison of alternative pre-treatment designs.

### **Methods**

*Raw water.* The raw water used in this study was prepared using a NOM concentrate from a full scale ion exchange treatment plant, which was mixed with tap water to make up an analogue water with a turbidity of around 1 NTU, a colour of  $55 \pm 1.78$  mg Pt/L at pH 7 (corresponding to an absorbance of  $2.25 \pm 0.12$  m<sup>-1</sup> at a wavelength of 436 nm),

a  $UV_{254}$ -absorbance of  $29.9 \pm 1.1 \text{ m}^{-1}$  and a DOC concentration of  $6.8 \pm 0.2 \text{ mg/L}$ . Analogue feed water ensures that the same experimental conditions apply for all experiments conducted. Previous studies have shown that this method can be successfully used and simulates real conditions quite well (Leiknes et al. 2005; Meyn and Leiknes 2010).

The organic matter concentrate used in this study can be characterized as highly hydrophobic and humic acid like. As already shown in Meyn and Leiknes (2010), a Fluorescence Excitation Emission Matrix (FEEM) of the raw water showed a very distinct peak in the humic acid like region. The organic matter can be further characterized by a relatively high SUVA of  $4.5 \text{ m}^{-1} \cdot \text{L}/\text{mg C}$ , indicating a high aromatic carbon content (Croue et al. 1999). After blending the concentrate with tap water the FEEM shows another dominant peak in the fulvic acid like region (Figure 1b). Fractionation analysis revealed that the dominant fraction (64%) of the raw water composition is the very hydrophobic acid (VHA) fraction. The VHA fraction is predominantly composed of higher molecular weight humic acids. Slightly hydrophobic acid (SHA) represents fulvic acid like components (Fabris et al. 2008). The results of the organic matter fractionation are shown in Figure 1a. Further comparison of the analogue raw water used in this study with natural water, obtained from a lake near Trondheim, Norway, showed no significant differences. It can be therefore concluded, that the results obtained in this study can be transferred to natural Norwegian water sources and are representative for Norwegian conditions.

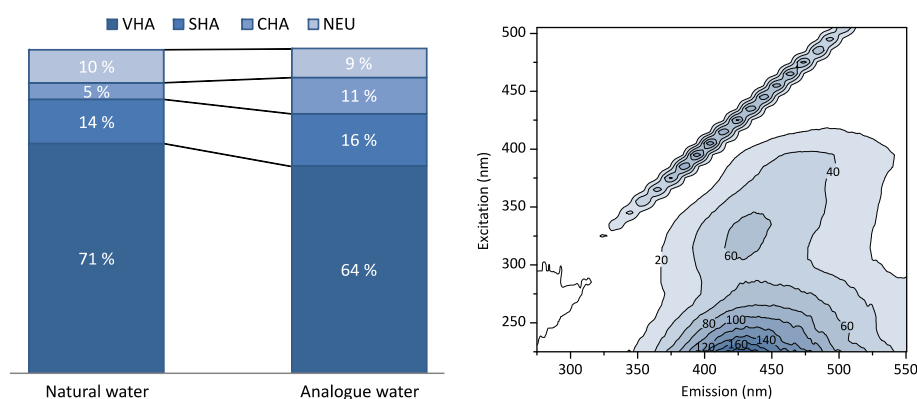

(a) Composition of natural Norwegian lake water and the analogue raw water used in this study (b) Fluorescence Excitation Emission Matrix of the raw water

Figure 1: Raw water characterization

*Pilot plant configuration.* Experiments were done with a membrane filtration pilot plant using an inline coagulation/ flocculation pre-treatment configuration, as shown in Figure 2. Prior to the membrane filtration unit, a static mixer ensured intensive mixing of coagulant into the already pH-adjusted raw water, followed by a slow mixing pipe flocculation step. After that, the coagulated water is filtered by the membrane unit. The pilot plant was equipped with 3 identical and independent process trains.

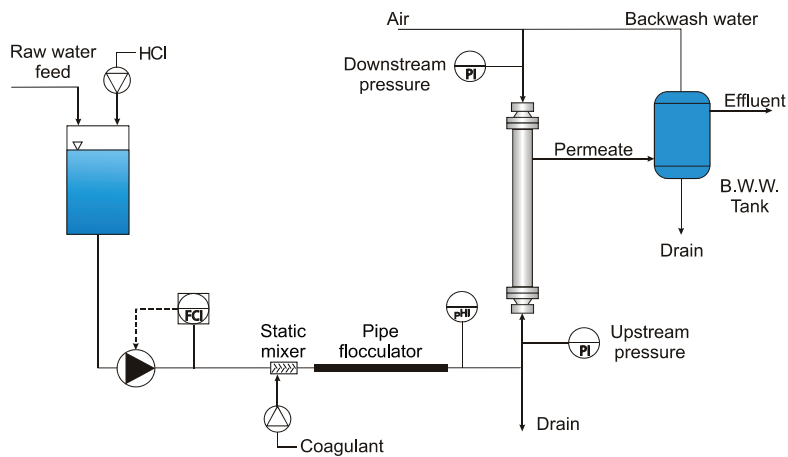

Figure 2: Exemplary flow diagram of one train of the membrane filtration pilot plant

In this study multi-channel ceramic membranes, operated in dead-end, inside-out mode with a nominal pore size of  $0.1 \mu\text{m}$  were investigated. Each membrane module is 1 m long with 55 channels giving an effective surface area of  $0.43 \text{ m}^2$ . The membrane modules are mounted vertically with feed water pumped in an up-flow direction. The plant was operated in constant flux mode, maintaining a flux of  $250 \text{ L}\cdot\text{m}^{-2}\cdot\text{h}^{-1}$  (Table 1). Regular cleaning was performed each hour by an initial backwash with pressurized permeate and then, after some seconds, by a simultaneous air blown into the feed channels. A pressurized tank was used for the backwash. The backwash pressure expands from initially 5 bar to about 2 bar at the end of the regular cleaning. The pressure of the air blow is likewise 2 bar. In total the regular cleaning cycle lasts about 10 seconds. The obtained sludge was discharged to the sewer system. The pilot plant also offers the possibility of chemical enhanced backwashing, e.g. by dosing acid, base or chlorine, however, these options were not used or found necessary in the experiments conducted. After each experiment the membrane modules were cleaned intensively by soaking alternating in citric acid solution ( $w = 1 \%$ ) and sodium hypochlorite solution ( $c = 3,000 \text{ ppm}$ ).



Table 1: Membrane operating conditions and module specification

|  |   |
|--|---|
| Membrane type                          | ceramic MF  |
| Module length / diameter               | 1 m / 0.03 m  |
| Channels per module                    | 55  |
| Channel diameter                       | 2.5 mm  |
| Module area / nominal pore size        | 0.43 m <sup>2</sup> / 0.1 μm                                |
| Operational flux / filtration velocity | 250 L·m <sup>-2</sup> h <sup>-1</sup> / 6 m·d <sup>-1</sup> |
| Regular cleaning intervals / procedure | 1 h / backwash and air blow                                 |

The process performance was assessed as a function of coagulant dosage and the flocculation G-value and flocculation time. The DOC and colour removal, irreversible and reversible fouling and residual aluminium concentration in the permeate were measured for evaluation of the process performance. Coagulant doses 2.6 and 4.4 mg Al/L were chosen, corresponding to about 0.4 and 0.65 mg Al per mg of DOC. It has been shown that for raw waters with a pH of 6 and high DOC not much NOM removal is achievable with doses significantly less than 2.6 mg Al/L, and where membrane fouling increases drastically, as stated in Meyn and Leiknes (2010) and confirmed by unpublished results. The G-values 4, 31, 98 and 300 s<sup>-1</sup> were investigated. The G-value range was chosen on the rationale that with a G-value of 4 s<sup>-1</sup> on the lower end and with 300 s<sup>-1</sup> on the upper end, the range covers extreme conditions with almost no to relatively turbulent mixing. Previous experiments have shown that ceramic microfiltration coupled only with rapid mixing pre-treatment and without any flocculation, removes the same amount of DOC and colour as an extensive classical 2-stage coagulation/flocculation pre-treatment (Meyn and Leiknes 2010). The irreversible fouling on the other hand was quite severe, indicating the need for further optimization of the process. Therefore, the three flocculation times were investigated (10, 60 and 240 s) to evaluate if there is a minimal necessary flocculation time, and to assess if a relatively long flocculation time of 240 s still has a beneficial effect compared to shorter times. Table 2 gives an overview of the flocculation conditions and the experimental design.

Table 2: Overview of the full factorial experimental design and the containing variables

| Role               | Name   | Values                      |    |     |     |
|--------------------|--|-----------------------------|----|-----|-----|
| Design Variables   | Coagulant Dose [mg Al/L]   | 2.6                         |    | 4.4 |     |
|                    | G-Value [ $s^{-1}$ ]   | 4                           | 31 | 98  | 300 |
|                    | Flocculation Time [s]  | 10                          | 60 | 240 |     |
| Response Variables | DOC-Removal [%]<br>Colour Removal [%]<br>Residual Aluminum [ $\mu g$ Al/L]<br>Irreversible Fouling [mbar/h]<br>Reversible Fouling [mbar/h] | Measured during experiments |    |     |     |

Polyaluminium chloride (PAX-18) supplied by Kemira Chemicals was used as coagulant. Coagulation pH was set to 6, which has shown to be optimal for removal of NOM with an aluminium based coagulant as stated in Vik et al. (1985) for conventional water treatment and in Meyn and Leiknes (2010) for coagulation/flocculation coupled with microfiltration. At pH 6 it is further expected that high residual Al concentrations in the permeate can be avoided. Each condition was tested for 48 hours or until the TMP reached 2 bar. The G-value in the static mixer was  $8000 s^{-1}$ . For adjustment of the various flocculation conditions tested, the pipe flocculator was constructed from tubes with different lengths and diameters as shown in Table 3.

Table 3: Pipe flocculator dimensions, length and diameter, used in this study

| G-value [ $s^{-1}$ ]  |     | 4               | 31    | 98    | 300   |
|-----------------------|-----|-----------------|-------|-------|-------|
| Tubing diameter [mm]  |     | 38              | 19    | 13    | 10    |
|                       |     | Tube length [m] |       |       |       |
| Flocculation time [s] | 10  | 0.26            | 1.06  | 2.23  | 3.80  |
|                       | 60  | 1.58            | 6.34  | 13.40 | 22.81 |
|                       | 240 | 6.33            | 25.36 | 53.60 | 91.24 |

The average velocity gradient in the tubes was calculated by relating the net power dissipated (P) in the fluid with the fluid volume (V) and the dynamic viscosity  $\mu$  of the fluid according to equation (1.1). It has the dimension  $s^{-1}$ .

$$G = \sqrt{\frac{P}{V\mu}} \quad (1.1)$$

The G-value created by a flow within a pipe can be calculated if the power dissipated in the pipe is known. This is given by

$$P = \dot{V} * \Delta p \quad (1.2)$$

where  $\dot{V}$  is the volumetric flow rate and  $\Delta p$  is the pressure drop across the length of the pipe. The Darcy–Weisbach equation can be used to calculate the pressure drop which is related to friction along a given length of pipe to the average fluid flow velocity:

$$\Delta p = f \frac{\rho}{2} v_a^2 \frac{L}{d} \quad (1.3)$$

where  $f$  is in this case the Darcy friction factor,  $\rho$  the fluid density,  $v_a$  the mean flow velocity,  $L$  the pipe length and  $d$  the pipe diameter. The friction factor is a function of the Reynolds number in the pipe and can be calculated in a laminar flow regime ( $Re < 2300$ ) by

$$f = \frac{64}{Re} \quad (1.4)$$

In a turbulent flow regime the pipe roughness needs to be considered as an additional effect. With increasing Reynolds numbers, the influence of the roughness grows. For smooth pipes, the Blasius equation can be used to calculate the friction factor for  $31 \times 10^3 < Re < 100 \times 10^3$ :

$$f = 0.3164 * Re^{-\frac{1}{4}} \quad (1.5)$$

During some experiments, the Reynolds number was in the critical transition range between laminar and turbulent flow of 2300 to 4000. Since the flow passed a static mixer right before entering the flocculation pipes it was assumed that the flow at the pipe inlet and throughout the pipes in those experiments was more turbulent than laminar. The impact of pipe roughness is rather insignificant in the range of small Reynolds numbers, as can be seen in the well-known Moody chart. In the transition region only a small influence of roughness is visible. Therefore the Blasius equation (1.5) was used to calculate the friction factor in turbulent flow. In the transitional region the value of the friction factor might be lower than the friction factors calculated for turbulent flow, but due to the fact that the exact state of the flow is not known and the variations in results are rather small, this simple approach is assumed to be applicable.

*Experimental design.* A full factorial 2x3x4 experimental design with two repetitions was chosen for this study. Such a design contains all possible combinations of factors and their interactions. The experimental matrix was carried out by using the pilot plant with three parallel independent process trains, where three experiments could be carried out at the same time. It was proven in previous experiments that different process trains or membrane modules do not have a significant effect on the experimental results. In total, 48 experiments were carried out.

The experimental design was analyzed with help of Multiple Linear Regression (MLR), minimizing the sum of squared residuals. Such a full linear first-order model for 3 independent parameters and all their interactions has the general form:

$$y = \beta_0 + \beta_1 x_1 + \beta_2 x_2 + \beta_3 x_3 + \beta_4 x_1 x_2 + \beta_5 x_1 x_3 + \beta_6 x_2 x_3 + \beta_7 x_1 x_2 x_3 + \epsilon \quad (1.6)$$

A linear second-order model, including also quadratic effects, was also considered. Such a model expresses a curvilinear relationship between a response variable and the design variables. The achievable fit and the model prediction of our real observations would have been better than with a linear first-order model. However, due to the strongly parabolic shape of such a regression the ability to actually interpolate between the investigated data points would have been very limited, since i.e. negative response values could occur. Hence, a linear first-order model was chosen.

Before the analysis, the design variables were negatively checked for potential multicollinearity, which would have affected the regression statistical relevant and thus should be avoided. In order to find the optimal model for each response a full model was analysed, including the 3 main effects and all their interactions. The full model was then used to identify and remove outliers and to check if a reasonable regression was possible and if significant factors were present in the model. An outlier was identified by having a standardized residual greater than 2.5. The regression was considered to be reasonable, if in a hypothesis test the hypothesis  $H_0$ , that all coefficients in the model are equal to zero, was rejected at a 0.05  $\alpha$ -level. In this test  $H_0$  was compared with a second hypothesis  $H_1$ , stating that at least one of the coefficients in the model is unequal to zero. The rejection of  $H_0$  does not automatically mean that  $H_1$  must be true, but it represents strong evidence that this is the case.

A stepwise regression was then performed, in order to simplify the models and to identify significant coefficients. This was done by alternating forward and backward stepwise regression steps. The regression algorithm includes the most significant term that satisfies the probability to enter the model and removes the least significant term satisfying probability to leave the model. It continues removing terms until the remaining terms are significant and then it changes to the forward direction again. The probability for leaving or entering the model was set to  $\alpha=0.05$ . For the resulting models an Analysis of Variance (ANOVA) was performed and the models were checked for assumption violations. It was i.e. confirmed by residual analysis, showing that the errors are independently and normally distributed with zero mean and a constant variance  $\sigma^2$ . The Anderson-Darling test was chosen for proving normality. If the p-value for the Anderson-Darling test was lower than the chosen significance level 0.05, it was concluded that the data do not follow the specified distribution. The adjusted and predicted  $R^2$  values of the models were calculated and compared. The adjusted  $R^2$  ( $R^2(\text{adj})$ ) estimates the percentage of response variable variation that is explained by its relationship with one or more predictor variables in the model rather than by random error.  $R^2(\text{adj})$  is adjusted for the number of predictors in the model, since the  $R^2$  for any model will always increase when a new term is added. A model with more terms may appear to have a better fit simply because it has more terms. The predicted  $R^2$  ( $R^2(\text{pred})$ ) indicates how well the model predicts responses for new observations and is calculated

by systematically removing each observation from the data set, estimating the regression equation, and determining how well the model predicts the removed observation.

As a last step, the obtained regression models were used for process optimization. All response variables were paired with a desirability function. Favourable size ranges of the responses were rated with a high desirability value, low desirability values were assigned to unwanted ranges. For the responses DOC and colour removal a desirability function for maximization was selected. The other responses residual aluminium, irreversible and reversible fouling, minimizing desirability functions were chosen. The residual aluminium concentration was further restricted by the limiting value of 150  $\mu\text{m Al/L}$ . Finally, the regression models were used for maximising the overall desirability to find a process optimum. All statistical analyses were done with the software packages Minitab® 15 and JMP® Statistical Discovery Software 8.

*Experimental analysis.* The membrane performance was monitored by logging the transmembrane pressure (TMP) development for constant flux operation. Samples were taken before the coagulation and after the membrane filtration twice a day during different stages in the process cycles. Turbidity measurements (90° scattered light method, Turbidimeter 2100N, Hach) and the residual metal concentration (measured by High Resolution ICP-MS at the Institute for Chemistry at NTNU) in the permeate were analysed for each sample. The removal of organic matter was monitored by measuring colour, UV-absorption at 254 and 436 nm (Spectrophotometer U-3000, Hitachi) and DOC (Laboratory analyser: Dohrmann Apollo 9000, Teledyne-Tekmar; Online spectrometric probe: Spectro::lyser™, s::can Meßtechnik GmbH, Vienna, Austria).

In this study measurements were conducted to distinguish between reversible and irreversible fouling. By definition, reversible fouling represents material that can be removed by regular cleaning procedures without using chemicals whereas irreversible fouling has to be removed by enhanced chemical cleaning. This is usually done when a defined level of the system permeability is undercut.

In the conducted experiments the TMP was measured for each cycle before and after a backwash. For calculation of the irreversible fouling rate the data points of the TMP at the beginning of a cycle, directly after a backwash, were linear approximated as shown in Figure 3 and the slope of the regression curve calculated. The slope represents the actual irreversible fouling rate during an experiment, expressed as pressure increase per amount of time with the unit mbar/h. The reversible fouling rate was calculated by linear approximating the TMP increase within a cycle and calculating the slope. This slope represents the actual reversible fouling rate in one cycle, expressed as pressure increase per amount of time with the unit mbar/h. This step was repeated for all experiments and the obtained fouling rates averaged, resulting in the overall reversible

fouling rate for one particular experiment. The reversible fouling rates measured for each cycle did not vary very much during an experiment and therefore the averaged rate is representative, even in cases where the irreversible fouling showed an exponential characteristic.

Jar tests were performed by applying rapid mixing at 400 rpm for one minute, followed by slow mixing at 40 rpm for 60 minutes. Acid for pH adjustment was dosed before the experiments, coagulant right before the rapid mixing started. Flock growth was monitored with a Photometric Dispersion Analyser 2000 (PDA 2000, Rank Brothers LTD, Cambridge, UK). The PDA measures the mean transmitted light intensity (dc value) and the root means square (rms) value of the fluctuating component. The ratio (rms/dc), in this study called flocculation index, provides a sensitive index of particle aggregation (Gregory and Nelson 1986). Zeta potential was measured with a Zetasizer Nano ZS (Malvern Instruments Ltd, Worcestershire, UK) at the beginning and end of the jar tests.

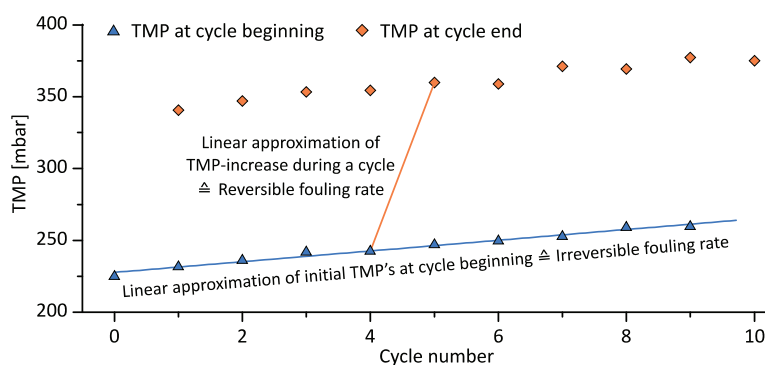

Figure 3: Exemplary calculation of reversible and irreversible fouling rate

### Results and discussion

*NOM removal.* The removal of DOC and colour, expressed as VIS436, depended only on the amount of dosed coagulant, since the pH-value was stable and set to 6 for all experiments. Flocculation time and G-value did not influence the amount of organic matter removed at all.

Depending on the coagulant dose, the DOC removal varied between 55% with an Al-dosage of 2.6 mg/L and 70%, achieved by dosing 4.4 mg Al/L (Figure 4). This corresponds to residual DOC concentrations of 3 mg/L and 2 mg/l respectively, with a raw water DOC of 6.8 mg/L. These removal rates are about 10 to 15% lower than previously observed in Meyn and Leiknes, (2010), for a comparable setup where similar raw water and coagulant doses were used but with a 30% lower DOC concentration of 5.2 mg/L. These results were therefore obtained with a significantly lower DOC/Al

ratio. However, the study further used a classical 2-stage tank-coagulation and flocculation pre-treatment configuration instead of an inline process, but with an otherwise similar setup. The different removal rates cannot be assumed caused by the modification in the process configuration, since the results presented in this study show that variation of the flocculation parameters did not influence the DOC removal, even at an extended flocculation time of 240s. The different DOC removal rates found in the two comparative studies are therefore caused only by the altered DOC/Al ratio. This conclusion corresponds well with preliminary results also published in Meyn and Leiknes, (2010), where a setup with tank pre-treatment was compared directly with a simplified inline setup, using iron chloride as coagulant. No significant difference in DOC removal was observed. DOC removal was reported to vary as a function of coagulation pH, with optimal removal using PACl as coagulant being at pH-values 5.5 to 6. Thus it can be concluded that the DOC removal for the processes combination presented in this study, provided that similar raw water is treated, only depends on the parameters pH-value and the coagulant dose.

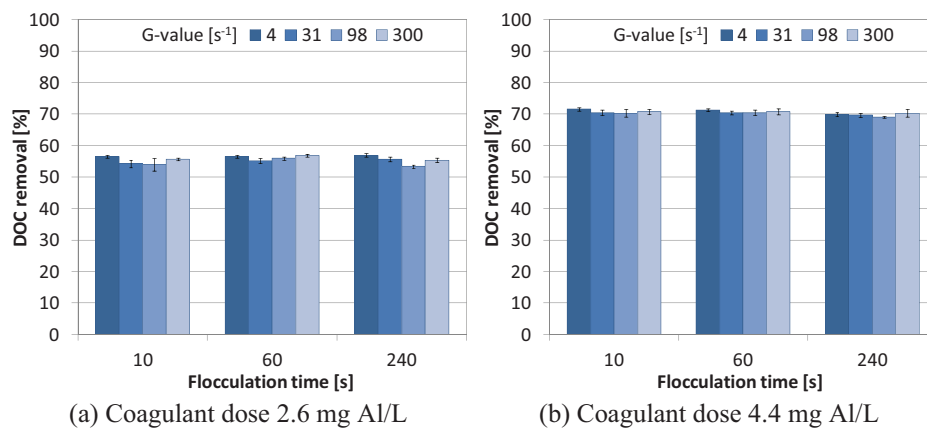

Figure 4: DOC removal dependence on flocculation time, G-value and aluminium dosage

The removal of UV absorbance and colour followed a similar pattern to that observed for DOC removal, but was generally on a higher level. Average removal of UV absorbance was around 71% for a coagulant dose of 2.6 mg Al/L and 88% for 4.4 mg Al/L respectively (Figure 5). Average colour removal was around 85% for a coagulant dose of 2.6 mg Al/L and 92% for 4.4 mg Al/L respectively (Figure 6). As already described and explained for DOC reduction, the removal of UV absorbance and colour only depend on the coagulant dose and not on flocculation time or G-value.

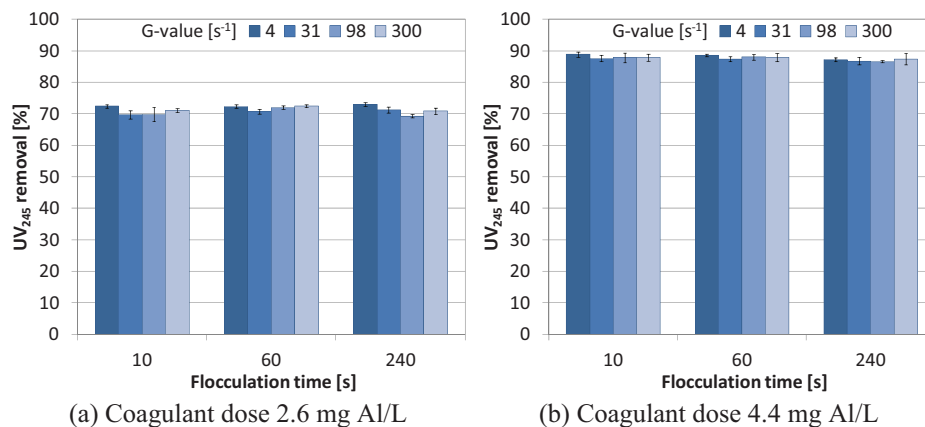

Figure 5: Removal of UV absorbance dependence on flocculation time, G-value and aluminium dosage

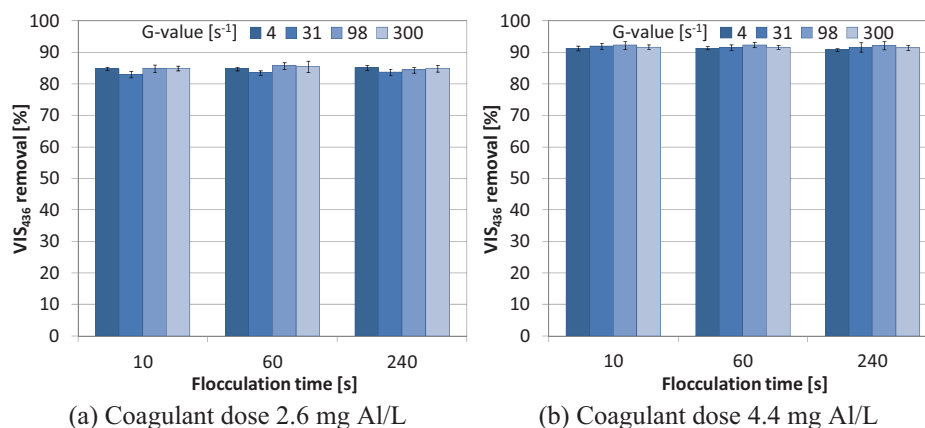

Figure 6: Colour removal dependence on flocculation time, G-value and aluminium dosage

The higher UV absorbance and colour removal compared to DOC can be explained by a favoured removal of a DOC portion, which can be characterized as a very hydrophobic high molecular weight fraction with high aromatic carbon content. This fraction generally expresses high colour and UV absorption. This preferential removal is reflected by the reduction of the specific UV absorbance from  $5.4 \text{ m}^{-1} \cdot \text{L} / \text{mg C}$  in the raw water to  $2.8 \text{ m}^{-1} \cdot \text{L} / \text{mg C}$  at an aluminium dosage of  $2.6 \text{ mg/L}$  and  $1.7 \text{ m}^{-1} \cdot \text{L} / \text{mg C}$  for  $4.4 \text{ mg Al/L}$ . LC-OCD analysis of the raw water and permeate confirms this observation. As can be seen in Figure 7a), the larger molecular weight fraction showing the highest UV absorption is preferentially removed. Figure 7b) shows that the absolute removal is greatest for the VHA fraction, the neutrals seem to accumulate in the permeate, even at higher coagulant dose. The favoured removal of colour and UV



absorbance over DOC corresponds well with findings of other studies, i.e. Owen et al. (1995). Vik et al. (1985) showed that raw waters containing more low molecular weight NOM species are more difficult to treat in terms of DOC removal than water sources with higher molecular weight NOM. This is generally the case where higher molecular weight humic acid species are easier to remove than the low molecular weight fulvic acid species.

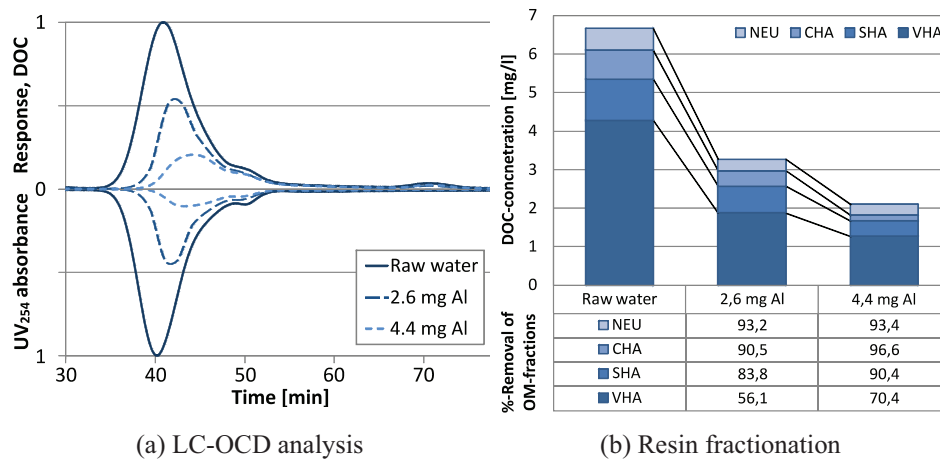
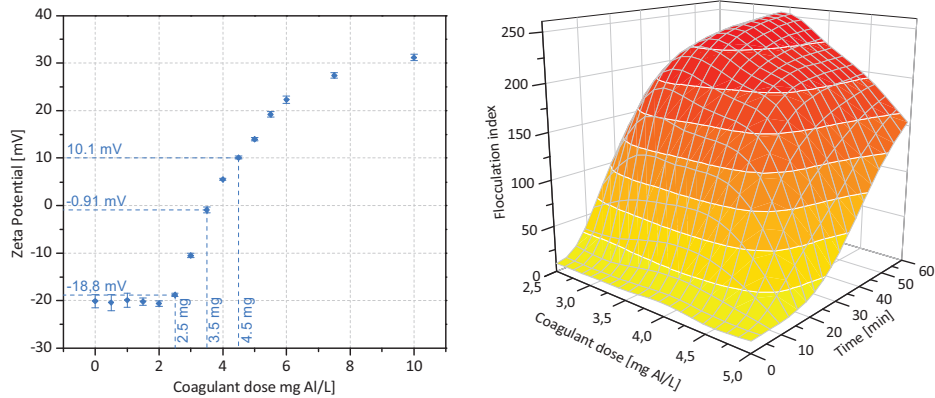

Figure 7: NOM characterization from raw water and permeate, treated with 2.6 and 4.4 mg AL respectively

To investigate possible coagulation pathways and for further characterization of the coagulation/flocculation system, a series of jar tests was performed, where raw water was coagulated at different coagulant doses and zeta potential and flock growth as a function of flocculation time were measured. As shown in Figure 8a, the zeta potential in the raw water has a negative value of -18.8 mV at an aluminium dose of 2.6 mg/L, whereas at 4.4 mg/L it is already positive, at around 10 mV. Zero zeta potential can be observed at a dose of around 3.5 mg Al/L. At this dose the biggest flocks were formed in the jar test and flock formation was fastest, as summarized in Figure 8b. Floc growth was monitored for 60 minutes at coagulant doses between 2.5 and 5.0 mg Al/L, in 0.5 mg intervals. The surface graph shown in Figure 8b was created by interpolating those data. However, the higher coagulant dose of 4.4 mg Al/L showed a superior organic matter removal compared to 2.6 mg Al/L and from the zeta potential measurements and jar tests one can assume that better removals may be observed at higher coagulant dosages, despite the more positive zeta potential.



(a) Zeta potential in the coagulated raw water in dependence on the coagulant dose (b) Jar test floc growth in dependence on coagulant dose and flocculation time

Figure 8: Interaction between surface charge and jar test floc growth controlled by coagulant dose at pH 6

Previous studies have shown that charge neutralization is the dominant coagulation mechanism only for low organic matter concentrations around a pH-value of 6. Shin et al. (2008) stated for example a DOC concentration of 2.7 mg/L in the raw water as the upper limit. If the concentration is below this value, only a very narrow window for charge neutralization exists in terms of coagulant dose and pH-value, since charge reversal occurs if the coagulant is overdosed. At higher DOC concentrations no restabilization by charge reversal was observed and the window for optimal organic matter removal was wider. Charge reversal still occurs at higher coagulant dosages, as can be seen in Figure 8a, but is compensated by formation of aluminium hydroxides, followed by adsorption of NOM and/or Al-NOM complexes on  $\text{Al}(\text{OH})_3(\text{s})$  with a continuous transition to precipitate enmeshment as the dosage is incrementally increased. Edwards and Amirtharajah (1985) and Vik et al. (1985) showed similar results. A further increase of coagulant could lead to a higher organic matter removal since for example more of the low molecular weight fraction can be coagulated, but the removal efficiency decreases due to an increasing consumption of coagulant per removed mg of DOC ratio. Reaction rates for  $\text{Al}(\text{OH})_3(\text{s})$  formation are lower than for destabilization reactions forming Al-NOM complexes, but they are high enough to ensure fast particle formation even at very short flocculation times. Results from testing a static mixer directly in front of the membrane module without a defined flocculation stage showed similar DOC and colour removal levels compared to the flocculation options tested in this study. It can be therefore concluded that in the pH and Al dose range investigated particles are always formed that can be efficiently retained by the membrane, independent of the flocculation conditions. The hollow channels as found in the membrane employed can work as a pipe flocculator themselves and therefore

support a further floc development. Due to the flow pattern in the channels a dense columnar cake layer is promoted at the dead-end points, but cake layer formation is alleviated on the rest of the membrane surface (Yonekawa et al. 2004).

*Residual Al concentration.* The residual aluminium concentrations measured depended on all three process variables as shown in Figure 9. In general it decreased with increasing coagulant dose. For the 2.6 mg Al/L dose, the residual concentration was higher than the limiting value in the drinking water guidelines (150  $\mu\text{g Al/L}$ ) in all cases except three experimental conditions. At a dose of 4.4 mg Al/L the residual Al level was generally lower with only four experimental conditions exceeding the limiting value. As already discussed in the previous section, at a higher coagulant dose more organic matter is removed, indicating that the interaction of aluminium species with themselves and with the organic matter is more efficient. It is most likely not only  $\text{Al}(\text{OH})_3(\text{s})$  that is better retained at a higher dosages, since the organic matter removal increased drastically at the same time.

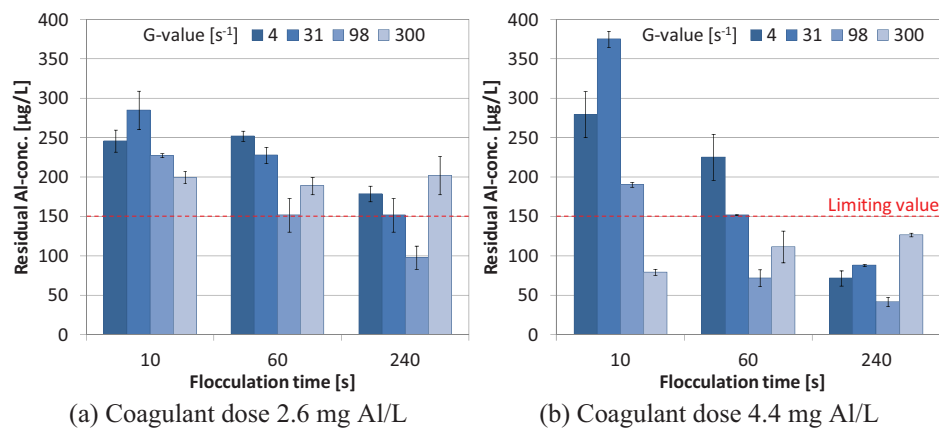

Figure 9: Residual metal concentration dependence on flocculation time, G-value and aluminium dosage

Increasing G-value had also a decreasing effect on the residual metal concentration with a restriction at a G-value of 300  $\text{s}^{-1}$  and flocculation times of 60 s and higher, where the residual Al concentration increases again. It can be generally stated that better mixing leads to lower metal concentrations, most likely due to increased contact and collision frequencies at higher turbulence. At a higher G-value smaller but more flocs are formed, increasing the total floc surface area and collision frequency, and therefore the chance that particles will interact and agglomerate. The results also indicate there may be an upper limit for the mixing intensity since the residual Al increased again at a G-value of 300  $\text{s}^{-1}$ . At a too high mixing intensities floc growth is possibly suppressed, with possible floc breakage, and therefore more Al is found in the permeate.

A longer flocculation time reduced the residual Al concentration, especially at a dosage of 4.4 mg Al/L. The more time the flocculation may proceed the less metal is found in the permeate. Interestingly, this has practically no effect on the organic matter removal, which depends on the coagulant dose only, as stated earlier. The reactions binding the organic molecules appear to be finished after a few seconds or even milliseconds, with the particles formed quickly reaching a state where they are efficiently retained by the membrane.

*Membrane fouling.* High irreversible fouling in the range of 5 to 25 mbar/h was observed at 10 s flocculation time. For longer times the fouling was generally found to have a low average value of 1.6 mbar/h, independent from the other two varied parameters, G-value and coagulant dose (Figure 10). The lowest fouling rate of 0.8 mbar/h was found at an Al dose of 4.4 mg/L, a G-value of 31 s<sup>-1</sup> and 60 s flocculation time. However, at 10 s flocculation time a higher G-value led to significantly reduced irreversible fouling. An exception must be made for a G-value of 4 s<sup>-1</sup>, where fouling was also lower. The coagulant dose had only a minor influence on the irreversible fouling. The differences in irreversible fouling at flocculation times of 60 and 240 s are very small and more experiments with different times are necessary to validate and to identify if the observed trends are consistent.

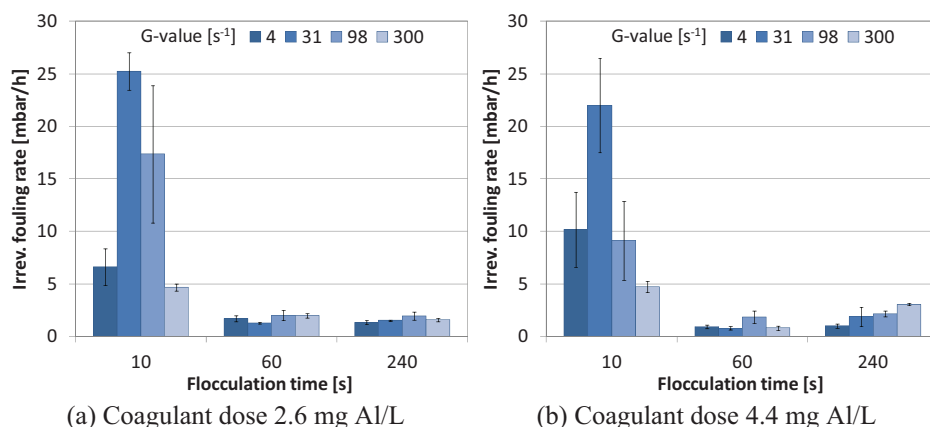

Figure 10: Irreversible fouling in dependence on flocculation time, G-value and aluminium dosage

From the results obtained it can be concluded that after a minimum flocculation time of 60 s the irreversible fouling was generally at a low level, independently from the other two varied flocculation parameters. As discussed for the residual metal concentration, these findings indicate that the flocculation reactions and particle aggregation are not completed after short flocculation times, even though the organic matter removal is not affected by this particle formation process. This fact can be visualized by in situ

measurements of floc size as a function of the flocculation conditions directly before the membrane. Results are shown in Figure 11. It can be clearly seen that the floc size is bigger at higher coagulant dose and higher flocculation times, but much lower compared to observations in the jar tests performed (Figure 8b). The size maximum at a 4.4 mg Al/L dose, 240 s flocculation time and a G-value of 98 s<sup>-1</sup> is possibly an indication that a further increase of mixing intensity up to 300 s<sup>-1</sup> leads to a suppressed floc growth and possible floc breakage which may further explain the increased residual metal concentrations at this G-value. However, measurements for a flocculation time of 10 s in particular are close to the detection limit of the analytical technique. According to the manufacturer the limits of particle size are roughly 0.5 to 100 µm. In general it can be concluded that after reaching a certain floc size level irreversible fouling was generally low, and where additional increase in floc size does not appear to further reduce the irreversible fouling.

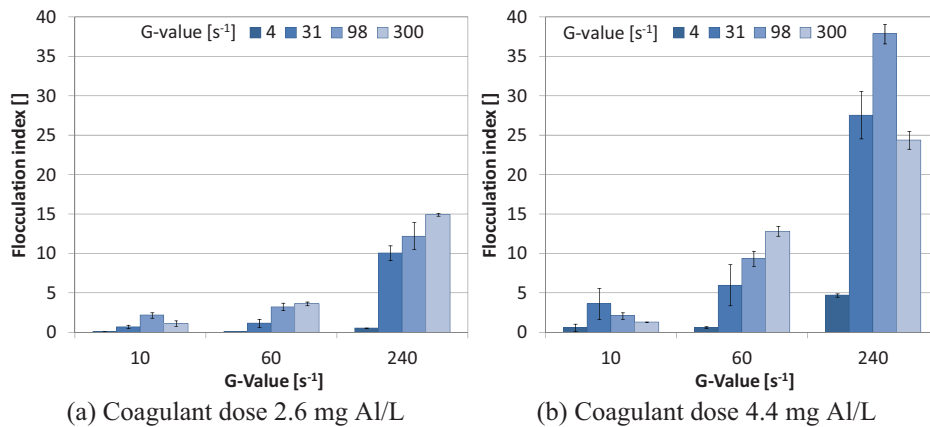

Figure 11: Flocculation index dependence on flocculation time, G-value and aluminium dosage

All investigated flocculation parameters had a strong influence on the reversible fouling as shown in Figure 12. Increased coagulant dosage elevated the reversible fouling, probably due to the increased organic matter removal and formation of particulate material thereby increasing solids load on the membrane. Increased mixing intensity or flocculation time generally decreased the reversible fouling, most likely due to a progressed aggregate formation, which then leads to a lower hydraulic resistance.

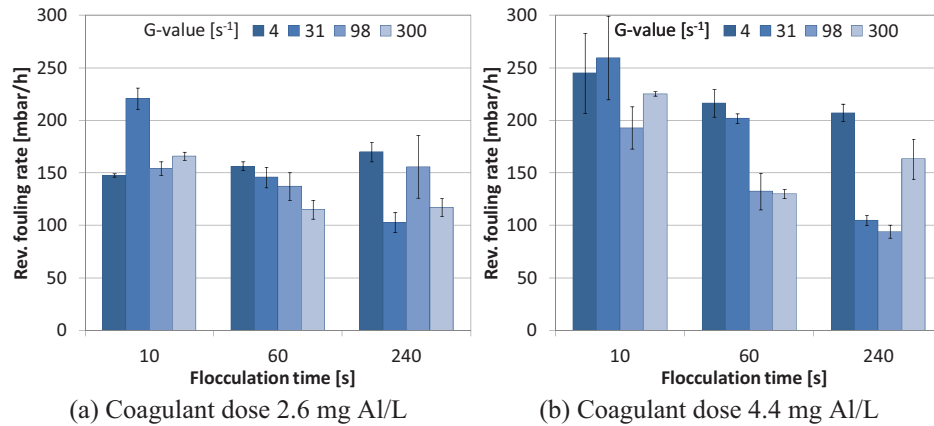

Figure 12: Reversible fouling rate dependence on flocculation time, G-value and aluminium dosage

*Design analysis.* By stepwise regression the flocculation parameters and their interactions having a significant influence on the process response parameters were identified. Table 4 shows the obtained regression coefficients for each response and the quality of the obtained model.

In general the models showed a good correlation, however some responses were less explainable by the applied predictors. The residual metal variation in the permeate was only explained by 70 % from the model, the reversible fouling even less by 50 %. Here obviously other parameters not investigated in this study play a role. For the irreversible fouling also a poor correlation was found due to a nonlinear relationship. Therefore the linear regression was split for two different flocculation intervals, one from 10 to 60s and the second from 60 to 240s. This was assumed to be reasonable since in Figure 10 it can be seen that the fouling dramatically decreases after an increase of flocculation time from 10 to 60s, and stays on a low level after a further increase to 240s. The two new models obtained showed very good correlation, explaining 96 and 80% of the variance respectively. However, it should be stated that a couple of outliers had to be removed, especially at a flocculation time of 10s, in order to be able to get a model following the requirement of a normal distribution of the model residuals. This is can be explained by the severe fouling occurrence in some experiments. Once the membranes reach a certain level of fouling no stable operation is no longer possible and the further performance decrease from that point is rather random and does not follow any ordered pattern.

Table 4: Results of multiple linear regression: Partial models with coefficients and quality parameters

| Response                   | Constant    | Predictors         |             |                 |        |        |        |        | No. of samples | No. of excluded outliers | R <sup>2</sup> (adj) [%] | R <sup>2</sup> (pred) [%] | Usefulness of model (p-Value) | Normality test of residuals (p-Value) |
|----------------------------|-------------|--------------------|-------------|-----------------|--------|--------|--------|--------|----------------|--------------------------|--------------------------|---------------------------|-------------------------------|---------------------------------------|
|                            |             | Coagulant Dose (A) | G-Value (B) | Flocc. Time (C) | AB     | AC     | BC     | ABC    |                |                          |                          |                           |                               |                                       |
| DOC Removal                | 33,969      | 8,296              |             |                 |        |        |        |        | 48             | 0                        | 98,1                     | 98,0                      | 0,000                         | 0,245                                 |
| VIS <sub>436</sub> Removal | 74,342      | 3,958              |             |                 |        |        |        |        | 48             | 0                        | 95,0                     | 94,7                      | 0,000                         | 0,908                                 |
| UV <sub>254</sub> Removal  | 47,405      | 9,168              |             |                 |        |        |        |        | 48             | 0                        | 98,1                     | 97,9                      | 0,000                         | 0,078                                 |
| Residual Al                | 341,247     | -28,299            | -0,312      |                 |        | -0,128 | 0,001  |        | 48             | 3                        | 69,7                     | 66,3                      | 0,000                         | 0,076                                 |
| Irreversible fouling at    | 10, 60      | 17,33              |             | -0,040          | -0,245 |        | -0,006 | 0,001  | 16             | 7                        | 96,3                     | 91,5                      | 0,000                         | 0,064                                 |
| flocc. time [s]:           | 60, 240     | 2,091              |             | -0,258          | 0,010  |        | -0,003 | -8E-05 | 32             | 3                        | 80,1                     | 73,5                      | 0,000                         | 0,088                                 |
|                            | 10, 60, 240 | 3,209              |             |                 | -0,007 |        |        |        | 48             | 8                        | 14,8                     | 8,1                       | 0,008                         | 0,203                                 |
| Reversible Fouling         | 76,553      | 37,630             |             | 0,649           | -0,041 | -0,260 | -0,002 | 0,001  | 47             | 2                        | 49,6                     | 40,6                      | 0,000                         | 0,199                                 |

The major trends discussed were confirmed and quantified as shown in Figure 13. It is apparent that all organic matter removal parameters are only influenced by the coagulant dose and not by the flocculation setup. The residual metal concentration decreased with increase of all three prediction parameters, but was influenced most by the interaction of dose and flocculation time followed by the G-value and coagulant dose. The reversible fouling behaviour was dominated by the coagulant dose and the interaction of dose and flocculation time. The irreversible fouling was influenced most by the flocculation time and the G-value at times lower or equal to 60s. At higher flocculation times no direct influence of this parameter was found. Interaction terms are dominating, where changes of one prediction parameter cause in how other prediction parameters influence the responses. At a low G-value the flocculation time has almost no effect on the irreversible fouling, but has a strong negative effect once the G-Value increases. At flocculation times of 60s the G-value has no influence on the irreversible fouling. At higher flocculation times an increasing G-value leads to increasing irreversible fouling. This behaviour is represented in Figure 13b) by the bar of the BC-interaction.

For process evaluation and optimization 5 different scenarios were assumed and investigated: a) Maximising the NOM removal; b) Minimisation of residual metal concentration; c) Minimisation of irreversible fouling; d) Combined maximisation of NOM removal and minimisation of residual metal and fouling; e) Same as d), but balancing treatment efforts with treatment needs and practical limitations.

Scenario a): Coagulant dose is the only parameter of interest. The other parameters do not influence the organic matter removal at all. Higher coagulant dose leads to increased removal, which is with 70.5 % highest at a dose of 4.4 mg Al/L. However, depending on the other settings high fouling and residual metal in the permeate are possible to occur.

Scenario b): The interaction of coagulant with flocculation time has the biggest influence on the residual metal concentration, followed by G-value and flocculation time (Figure 13d). They are further inversely proportional to the residual metal. At a coagulant dose of 4.4 mg Al/L and a flocculation time of 240 s the residual Al content is within a range of 82.0 to 93.5  $\mu\text{g Al/L}$ . At these conditions however, an increase of the G-value has an increasing effect on the residual metal concentration due to the BC-interaction. Therefore the residual metal concentration is minimized at a G-value of  $4\text{s}^{-1}$ .

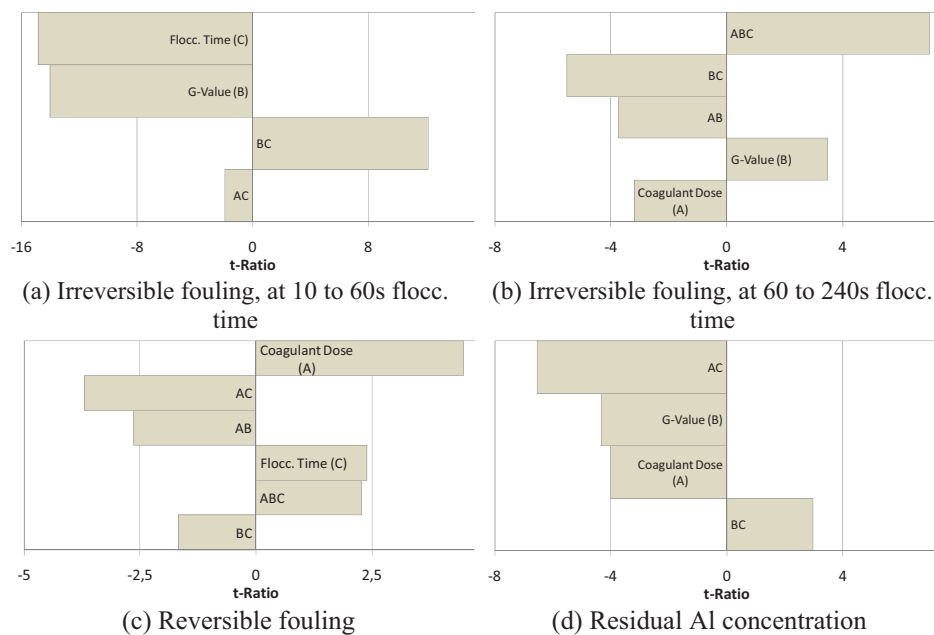

Figure 13: Standardized effects of predictor variables and their interactions on different process performance parameters

Scenario c): For minimisation of the irreversible fouling, the flocculation time should be equal to or higher than 60s. In that time range higher coagulant dose reduces irreversible fouling, as can be derived from Figure 13b). However, due to the additionally dominant interaction terms fouling can be minimised by choosing a shorter flocculation time of 60s, where the irreversible fouling is in the range of 0.96 to 1.03 mbar/h, at a coagulant dose of 4.4 mg Al/L. The G-value does not play a role at these conditions. The irreversible fouling stays in the stated range also at higher flocculation times, but only if the G-value is kept on a low level, otherwise the fouling increases significantly again.

Scenario d): High coagulant dose of 4.4 mg Al/L and high flocculation time of 240 s maximise the organic matter removal (70.5 %) and decrease the residual metal concentration (82.0 mg Al/L). At these conditions the G-value has to be low at  $4\text{s}^{-1}$  to suppress irreversible fouling, leading to an irreversible fouling rate of 0.98 mbar/h.



Furthermore, these conditions are beneficial for reduced reversible fouling, since a low G-value and higher coagulant dose have a decreasing effect under the stated conditions, resulting in a reversible fouling of 124 mbar/h. The pipe flocculator designed for these conditions would have a diameter of 38 mm and length of 6.33 m and is not suited for practical use, since it consumes a lot of space and diminishes the advantages of inline flocculation.

Scenario e): As can be seen from the results of scenario d) further optimisation is necessary, including practical considerations. A flocculation time of 240 s and a G-value of  $4 \text{ s}^{-1}$  maximise the space needed for the pipe flocculator. Depending on the raw water quality it might not be necessary to achieve maximum organic matter removal at 4.4 mg Al/L, as long as disinfection precursors and colour are efficiently removed. However, the results presented in this study show that a high coagulant dose maximizes the organic matter removal but reduces residual metal and irreversible fouling at the same time and a dose 4.4 mg Al/L therefore maximises the overall desirability. The minimization of the residual metal concentration is achieved at cost of a more extensive treatment by increased time, dose and pipe diameter, but it only has to be below the limiting value. The results discussed earlier show that a flocculation time of 60 s is high enough to prevent extensive fouling, but also to keep the residual Al concentration down and further reduce the pipe flocculator size. 60 s were therefore chosen as being optimal. Finally a G-value had to be selected high enough to press the residual metal concentration below  $150 \mu\text{g/L}$ , which was the case at  $150 \text{ s}^{-1}$ . The residual metal concentration could be further decreased by a higher G-value. This would lead to a diameter decrease and therefore length increase of the pipe flocculator, which is not desirable. Figure 14 summarises the process performance as a result of the optimised flocculation parameters according to scenario 5. At a coagulant dose of 4.4 mg Al/L, a G-value of  $150 \text{ s}^{-1}$  and a flocculation time of 60 s the DOC removal would be at 70.5 %, the residual metal concentration at  $149 \mu\text{g/L}$ , the membrane would irreversibly foul with a rate of 1 bar/h and the reversible fouling would be at 197 mbar/h. The pipe flocculator would have a tube length of 3.8 m with a diameter of 12.3 cm, provided for a flux of  $250 \text{ L}\cdot\text{m}^{-2}\cdot\text{h}^{-1}$ .

### Conclusions

Inline coagulation/flocculation coupled with ceramic microfiltration is a promising treatment alternative for low turbidity waters with a high organic matter content. Depending on the adjusted flocculation conditions, this hybrid process efficiently removed organic matter up to 70 % and colour up to 90 %. Low irreversible fouling of below 1 mbar/h was achieved at the same time, operating at a high flux of  $250 \text{ L}\cdot\text{m}^{-2}\cdot\text{h}^{-1}$ . Furthermore, it is possible to push the residual aluminium concentration below the limiting value of 150 mg/L. However, if the flocculation process is not optimized high membrane fouling and residual metal concentrations are likely to be the consequence.

The organic matter removal turned out to be very robust, by only depending on the applied coagulant dose and not at the other varied flocculation conditions at all. In contrast, membrane fouling and residual metal were quite sensitive to changes of all flocculation parameters. Generally it can be stated that there is a minimum flocculation time needed for the prevention of irreversible membrane fouling. In this study, this was found to be at 60 s. However, the true minimum flocculation time can be lower, since no times between 10 and 60 s were tested. This should be investigated further, since a reduction of flocculation time would lead to shorter pipe flocculators and less space consumption. In addition longer flocculation times help to reduce the residual metal concentration and the reversible fouling. Nonetheless, it is not desirable in practise to extend the flocculation time across a reasonable amount, since the result would be expensive and space consuming flocculator units. Therefore it has been attempted to balance actual treatment needs with treatment efforts.

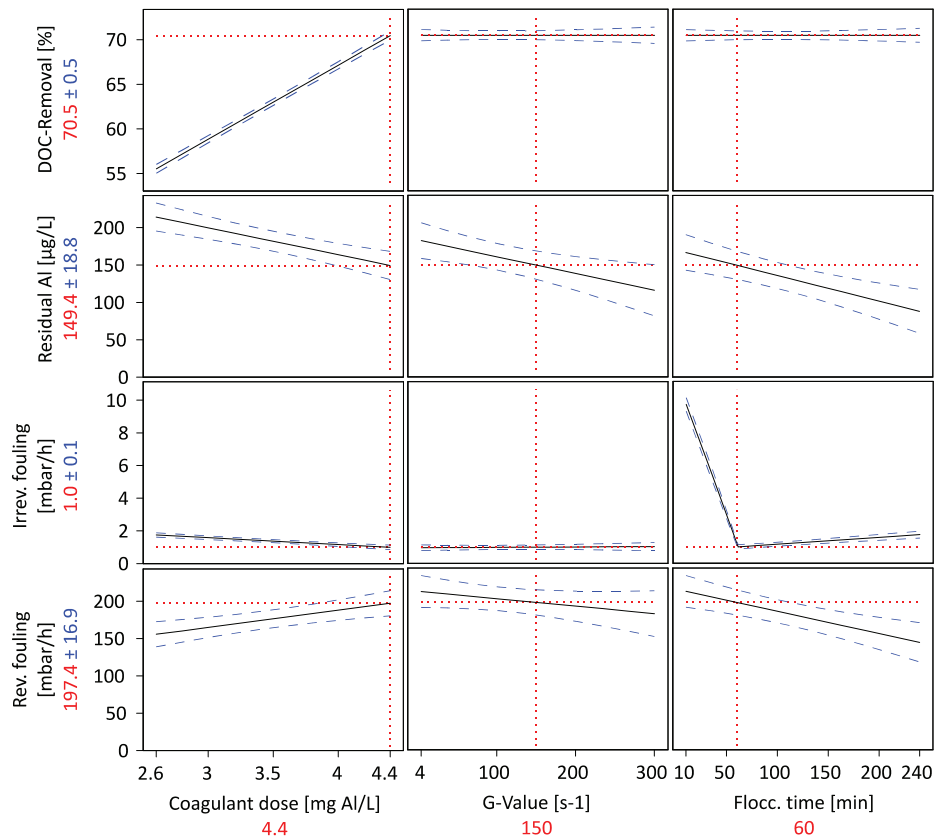

Figure 14: Optimized flocculation parameters according to scenario 5 and their effect on the process performance, colour code: black - modelling results; blue - 95% confidence interval; red - optimized conditions

Since the organic matter removal did not depend on the flocculation setup and only the coagulant dose, it is assumed that the reactions binding the organic molecules are finished after a few seconds or even milliseconds, leading to an efficient retention of organic matter by the membrane already after only 10 s of flocculation, even at conditions with almost no mixing in the flocculation stage. If additional flocculation time is provided the removal does not change, suggesting that the rest of the time is just used for particle shaping for fouling minimization. Since the residual metal concentration decreases as well with longer flocculation times it is assumed that charge neutralization and sweep flocculation occur in parallel. Charge neutralisation and bridging very fast creates microflocs, which can then be retained by the membrane. If longer flocculation time is provided  $\text{Al}(\text{OH})_3(\text{s})$  can form and sweep flocculation occurs, resulting in bigger flocs which can be detected by the PDA. These processes are supported by the flow pattern in the membrane channels, which act as a pipe flocculator themselves. As long as the particles entering the membrane have a characteristic that they do not block the membrane pores or stick to the surface, the flow pattern in the channels will allow further flocculation and deposit the particles at the end of the channels near the dead end points.

#### **Acknowledgements**

The authors would like to thank Metawater, Japan for providing the filtration pilot plant and the ceramic membranes. S::can Messtechnik GmbH, Vienna, Austria, is acknowledged for providing the spectrometric probe. The Norwegian Research Council and the TECHNEAU project we would like to thank for their financial support.

#### **References**

- Abrahamsson, J., U. Eriksson, G. Milton, J. Clement, K. Rogalla, K. Hattori and K. Yambe (2007). Ceramic Membranes and Coagulation for TOC Removal from Surface Water. 12th Gothenburg Symposium 2007, Ljubljana, Slovenia, IWA Publishing.
- Croue, J. P., J. F. Debroux, G. Amy, G. Aiken and J. A. Leenheer (1999). Natural Organic Matter: Structural Characteristics and Reactive Properties. Formation and Control of Disinfection By-Products in Drinking Water. P. C. Singer. Denver, CO, American Water Works Association.
- Edwards, G. A. and A. Amirtharajah (1985). "REMOVING COLOR CAUSED BY HUMIC ACIDS." *Journal American Water Works Association* 77(3): 50-57.
- Fabris, R., C. W. K. Chowa, M. Drikas and B. Eikebrokk (2008). "Comparison of NOM character in selected Australian and Norwegian drinking waters." *Water Research* 42(15): 4188-4196.
- Forsberg, C. (1992). "Will an Increased Greenhouse Impact in Fennoscandia Give Rise to More Humic and Colored Lakes." *Hydrobiologia* 229: 51-58.

Gregory, J. and D. W. Nelson (1986). "MONITORING OF AGGREGATES IN FLOWING SUSPENSIONS." *Colloids and Surfaces* 18(2-4): 175-188.

Hongve, D., G. Riise and J. F. Kristiansen (2004). "Increased colour and organic acid concentrations in Norwegian forest lakes and drinking water - a result of increased precipitation?" *Aquatic Sciences* 66(2): 231-238.

Leiknes, T., M. Lazarova and H. Odegaard (2005). "Development of a hybrid ozonation biofilm-membrane filtration process for the production of drinking water." *Water Science and Technology* 51(6-7): 241-248.

Meyn, T. and T. O. Leiknes (2010). "Comparison of optional process configurations and operating conditions for ceramic membrane MF coupled with coagulation/ flocculation pre-treatment for the removal of NOM in drinking water production." *Journal of Water Supply: Research and Technology - Aqua* 59(2-3): 81-91.

Owen, D. M., G. L. Amy, Z. K. Chowdhury, R. Paode, G. McCoy and K. Viscosil (1995). "NOM characterization and treatability." *American Water Works Association Journal* 87(1): 46-63.

Ratnaweera, H., N. Hiller and U. Bunse (1999). "Comparison of the coagulation behavior of different Norwegian aquatic NOM sources." *Environment International* 25(2-3): 347-355.

Shin, J. Y., R. F. Spinette and C. R. O'Melia (2008). "Stoichiometry of coagulation revisited." *Environmental Science & Technology* 42(7): 2582-2589.

Vik, E. A., D. A. Carlson, A. S. Eikum and E. T. Gjessing (1985). "REMOVING AQUATIC HUMUS FROM NORWEGIAN LAKES." *Journal American Water Works Association* 77(3): 58-66.

Yonekawa, H., Y. Tomita and Y. Watanabe (2004). "Behavior of micro-particles in monolith ceramic membrane filtration with pre-coagulation." *Water Science and Technology* 50(12): 317-325.

Ødegaard, H., S. Østerhus, E. Melin and B. Eikebrokk (2010). "NOM removal technologies – Norwegian experiences." *Drinking Water Engineering and Science* 3(1-9).

## 6.5 Publication 5

The subsequent poster with the title “Membrane fouling in a coupled coagulation - ceramic microfiltration system caused by natural organic matter” was presented at the 5<sup>th</sup> IWA Specialised Membrane Technology Conference for Water and Wastewater Treatment, 1. to 3. September 2009, Beijing, China.

The results presented in this study were obtained during a 3-month research visit in autumn and winter 2008 at the Hokkaido University in Sapporo, Japan. There, a small bench scale filtration unit was used, applying ceramic membrane modules of 10 cm length. Besides that, the modules were identical with the ones used in all other studies. Scope of the experimental series was to determine the influence of different kinds of organic matter on the filtration performance and the membrane fouling. Two types of raw waters have been compared, based on Aldrich Humic Acid and on the Norwegian NOM concentrate commonly used before. The NOM was coagulated inline with PACl and the aluminium dosage as well as the pH was varied. The process performance was evaluated as a function of DOC and colour removal, membrane fouling and residual metal concentration.



## Membrane fouling in a coupled coagulation - ceramic microfiltration system caused by natural organic matter

T. Meyn<sup>1</sup>, H. Yamamura<sup>2</sup>, K. Kimura<sup>2</sup>, T. O. Leiknes<sup>1</sup> and Y. Watanabe<sup>3</sup>

<sup>1</sup>NTNU - Norwegian University of Science and Technology, Dep. of Hydraulic and Environmental Engineering, 7491 Trondheim, Norway

<sup>2</sup>Graduate School of Engineering, Hokkaido University, N13W8, Sapporo 060-8628, Japan

<sup>3</sup>Center for Environmental Nano and Bio Engineering, Hokkaido University, N13W8, Sapporo 060-8628, Japan  
(E-mail: thomas.meyn@ntnu.no)

### Introduction

Due to the presence and further increase of natural organic matter (NOM) in natural water sources new NOM robust potable water treatment options, such as coagulation pre-treatment, combined with MF ceramic membrane filtration, are being investigated. Although NOM is not harmful by itself, it can cause colour, taste and odour problems, lead to bacterial regrowth in the distribution system or promote disinfection by-product formation. Raw waters containing two different types of NOM, Aldrich Humic Acid (AHA) and Norwegian Humic Acid (NHA), have been treated under varying coagulation conditions to investigate the impact on the membrane filtration performance.

### Experimental setup

**Table 1:** Raw water quality

|                            | AHA         | NHA         |
|----------------------------|-------------|-------------|
| DOC [mg/L]                 | 5.0 ± 0.3   | 5.0 ± 0.3   |
| UV <sub>254</sub> [Abs/m]  | 34.6 ± 1.4  | 23.8 ± 0.8  |
| VIS <sub>330</sub> [Abs/m] | 9.29 ± 0.46 | 1.97 ± 0.23 |
| Turbidity [NTU]            | < 2         | < 2         |

**Table 2:** Coagulation conditions

|   |                      |
|---|----------------------|
| Coagulant type  | PACl                 |
| Coagulant dose  | 1, 3, and 5 mg Al/L  |
| Investigated pH-values                                  | 5, 6 and 7           |
| Velocity gradient in the static mixer                   | 1000 s <sup>-1</sup> |
| Hydraulic retention time in the static mixer            | 5.4 s                |
| Total coagulation time (mixer + piping before membrane) | 20.7 s               |

**Table 3:** Membrane properties

|                          |  |   |
|--------------------------|--|---|
| Membrane type            | ceramic MF                                 |  |
| Module length / diameter | 0.1 m / 0.03 m                             |   |
| Channels per module      | 55   |   |
| Module area              | 0.0364 m <sup>2</sup>                      |   |
| Nominal pore size        | 0.1 µm                                     |   |
| Operational flux         | 250 L/(m <sup>2</sup> h)                   |   |
| Operation time           | 24 h                                       |   |
| Backwash procedure       | Every 1h with permeate and pressurized air |   |

**Pilot plant configuration**

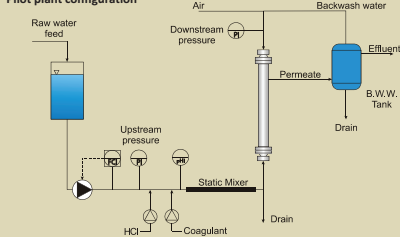

### Conclusions

- Good overall process performance possible in spite of high flux, very short coagulation time and only static mixing
- At optimized conditions: low irreversible fouling potential, efficient colour and DOC removal and low residual metal concentrations
- AHA, having a higher molecular weight and aromatic content, was removed significantly better than the less aromatic and smaller NHA

### Results

#### Aldrich Humic Acid Norwegian Humic Acid

##### Irreversible Fouling

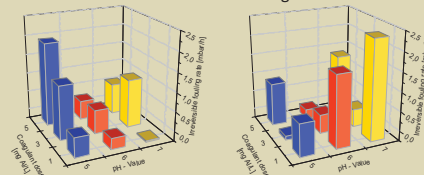

- Irreversible fouling generally low, no clear trend, NOM types behave different

##### Reversible Fouling

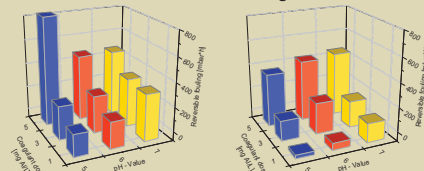

- Reversible fouling increased with an increasing coagulant dose and pH-value

##### DOC removal

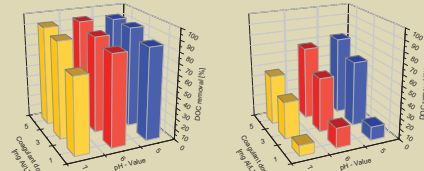

- Low pH and high coagulant dose promote DOC removal, AHA preferably removed

##### Residual Al concentration

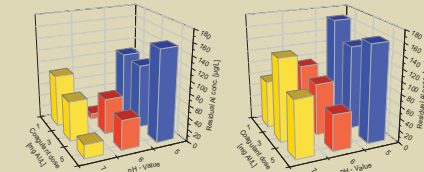

- Residual Al concentration always below 200 µg/L, minimum at pH 6

### Acknowledgements

- Hokkaido University and the Research Center for Environmental Nano and Bio Engineering, Sapporo, Japan, for the possibility to have a research visit
- Metawater Co., Ltd., Japan, for providing the pilot unit and ceramic membranes
- Det Norske Veritas for the travel scholarship





## Additional results

### 7.1 Process performance without coagulation

In order to evaluate the influence and effects of coagulation pre-treatment, the treatment scheme has to be operated without coagulation, without any pre-treatment. Thus, a triplicate of experiments was set up without any coagulant addition, but with adjustment to a pH of 6. The plant was operated for 48 hours and a normal backwash with permeate was carried out every 60 minutes. A summary of the results is shown in Table 7.1. NOM was only poorly removed and the membrane fouling, both reversible and irreversible, was very high compared to experiments carried out with suitable coagulation. As for example shown in Chapter 6.4, irreversible membrane fouling can be kept well below 2 mbar/h by applying inline coagulation pre-treatment. However, if coagulation is not optimised much higher fouling rates can be observed, compared to the fouling just caused by NOM itself. The reversible fouling on the other hand was very low compared to experiments with coagulation. This is not surprising since retention of coagulated NOM causes a rapid filtration resistance build-up compared to most likely just adsorbed NOM, if coagulation is omitted.

Table 7.1: NOM removal and membrane fouling without coagulant addition at a constant flux of 250 L/(m<sup>2</sup> h)

| Parameter            | Value       | Unit    |
|----------------------|-------------|---------|
| Feed water DOC       | 6.50 ± 0.04 | mg C/L  |
| Removed DOC          | 0.62 ± 0.17 | %       |
| Feed water colour    | 42.8 ± 0.4  | mg Pt/L |
| Removed colour       | 3.91 ± 0.32 | %       |
| Irreversible fouling | 5.1 ± 0.7   | mbar/h  |
| Reversible fouling   | 33.2 ± 15.3 | mbar/h  |

The development of membrane fouling was linear except in one experiment, where it started to accelerate exponentially after 35 h and the experiment had to be stopped shortly after. All three experiments had in common that for the first couple of hours no noticeable development of reversible fouling was observed. This changed over time and a stable reversible fouling of around 33 mbar/h was monitored, as shown in Figure 7.1. This change may be seen as the beginning of serious membrane fouling, leading eventually to rapid permeability deterioration as it has been observed in one out of the three performed experiments. However, together with the increased membrane fouling, no significant change in NOM removal was measured.

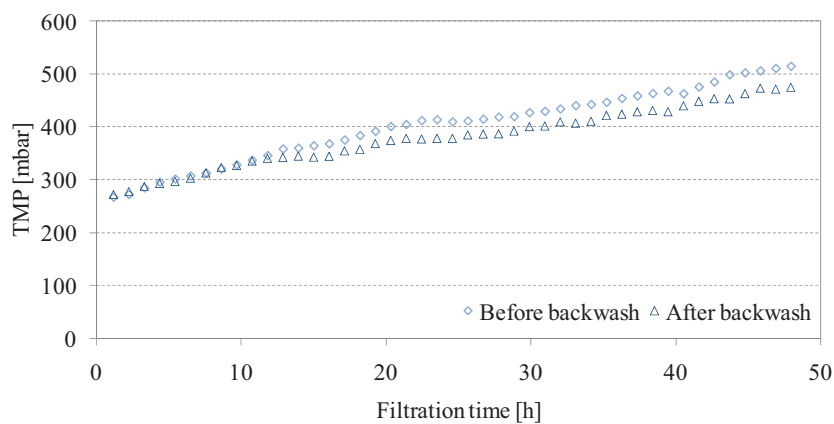

Figure 7.1: Typical TMP development for filtration without coagulation pre-treatment

It was concluded that ceramic microfiltration and most likely microfiltration in general is not suitable for treatment of typical Nordic waters since only a negligible amount of DOC and colour are removed and membrane fouling is rather high. Thus, a pre-treatment step such as coagulation and flocculation is required in order to improve the permeate quality and to reduce the membrane fouling.

## 7.2 Analogue vs. natural water

As was described in greater detail in Chapter 5.3, analogue raw water was used in this study as the raw water. This is suitable for extended experimental series, since it makes trials independent from natural raw water quality changes, i.e. during spring and autumn variations. Furthermore, the water temperature and other experimental conditions can be controlled and kept constant within a certain range. However, such a methodology may raise the question of how representable and transferable results obtained are in practise. Therefore, water was taken from a lake near Trondheim and two experiments were conducted, directly comparing the process performance in dependence of the raw water.

Two pre-treatment configurations were compared, tank coagulation as illustrated in Figure 5.1a) on page 84 and inline coagulation with pipe flocculation (Figure 5.1 d)). The tank coagulation consisted of rapid and short mixing and had a total HRT of 20 minutes. More details of the setup can be found in Publication 1. The inline coagulation setup is detailed described in Publication 4. After a static mixer a pipe flocculator was placed, having a HRT of 60 s and inducing a velocity gradient of  $31 \text{ s}^{-1}$ . These conditions have been identified as suitable for improved process performance (Publication 4). PACl was applied as coagulant, with a dosage of  $3 \text{ mg Al/L}$  at a coagulation pH of 6. The filtration flux was set to  $250 \text{ L}/(\text{m}^2 \text{ h})$  and a normal backwash was carried out every 60 minutes. Experimental duration was between 30 to 48 hours. Each experimental condition was tested once. The characteristics of the two raw waters are summarised in Table 7.2 and more details are provided in Chapter 5.3 (page 87).

Table 7.2: Characteristics of natural lake water and the analogue

| Parameter and unit  | Natural water | Analogue water |
|---|---------------|----------------|
| DOC [mg/L]  | 5.9           | 6.8            |
| BDOC [mg/L]   | 0.2           | 0.6            |
| Colour [mg Pt/L]  | 40.8          | 47.8           |
| SUVA [ $\text{L} \cdot (\text{m} \cdot \text{mg C})^{-1}$ ] | 4.3           | 4.5            |
| Alkalinity [mM/L]   | 0.38          | 1.5            |
| Calcium [mg/L]  | 7.1           | 18.2           |
| pH []   | 6.98          | 9.11           |
| Turbidity [NTU]   | < 1           | < 1            |

As can be seen from Figure 7.2, irreversible fouling was drastically lower in experiments with natural water, independent of the pre-treatment setup. While the coagulated lake water fouled the membrane with equal to or less than  $0.15 \text{ mbar/h}$ , the fouling rate was 15 to 20 times higher when treating the analogue water. Furthermore, the fouling rates observed for the analogue water were higher than previously observed under similar experimental conditions. As shown in Publication 4, irreversible fouling rates around  $1 \text{ mbar/h}$  should be expected with inline coagulation. With respect to the irreversible fouling, results in the same order of magnitude were obtained for both waters. As observed in previous experiments, reversible fouling is significantly reduced if tank coagulation is applied. The values for the reversible fouling are within the range previously observed.

Percentage DOC and colour removal were about 10 % higher for the natural raw water (Figure 7.3 a)), possibly due to the fact that more coagulant was dosed per mg DOC in that case. On the other hand, the NOM characterisation results presented in Chapter 5.3 suggest that NOM removal from the natural water should be less efficient compared to the analogue water, since it contains less humic substances and large molecular weight NOM which should be readily removed with coagulation and more low molecular

weight and neutral substances, which are assumed to be less prone to coagulation. Nevertheless, both waters have a rather high SUVA, indicating a NOM characteristic which is well suited for coagulation pre-treatment as discussed in Chapter 3.4. Moreover, DOC and colour removal did not depend on the coagulation setup, but only on the coagulant dosage. This is consistent with previous findings. As shown in Figure 7.3 b), higher residual metal concentrations were observed for the treatment of the analogue water. While no influence of the coagulation pre-treatment was found for the analogue water, tank coagulation produced significantly lower residual Al compared to the inline setup in the case of the natural water. However, all values were below the legal limit of 150  $\mu\text{g/L}$ .

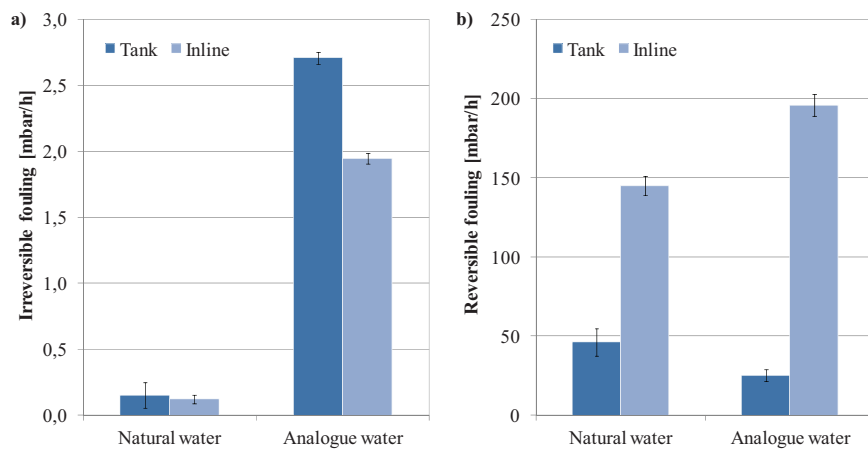

Figure 7.2: Irreversible and reversible membrane fouling in dependence on raw water type and pre-treatment setup

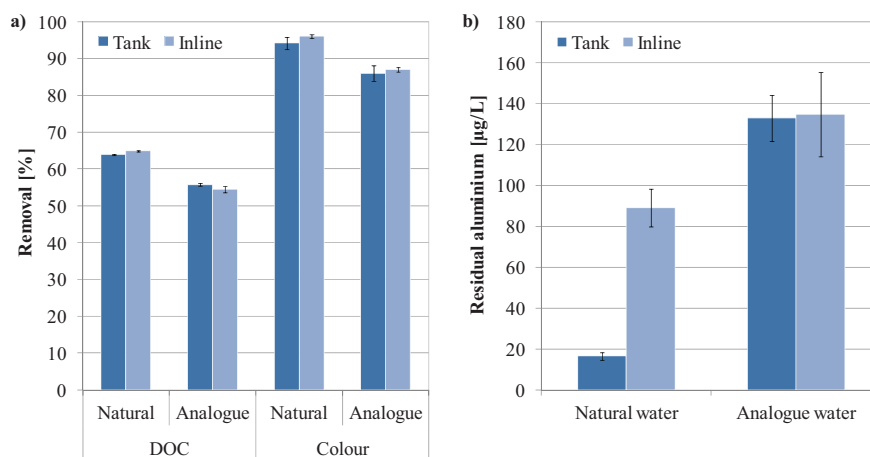

Figure 7.3: NOM removal and residual metal concentration in dependence on raw water type and pre-treatment setup

Since NOM removal was efficient and residual metal concentration low, it may be concluded that the coagulation of the natural water was very efficient and thus fouling by NOM was sufficiently suppressed and deposited material on the membrane surface was well removable by backwashing. However, aside from some differences in the NOM composition, the major difference of the two waters was found in the alkalinity and the calcium content, since the Trondheim tap water is stabilised and hardened by dosing CO<sub>2</sub> and subsequent marble filtration. This difference is assumed to be responsible for the increased irreversible membrane fouling observed for the analogue water. Multivalent cations such as calcium are able to form bridges between the negatively charged membrane surface and also negatively charged NOM molecules, even if present in low concentrations (Yoon et al., 1998; Yamamura et al., 2007). Nevertheless, the results shown in this chapter indicate that the treatment of real Nordic waters by the treatment scheme investigated in this study is a viable option.

### 7.3 Comparison of PACl and non-polymerised AlCl<sub>3</sub>

Most of the experiments in this study were conducted with PACl, since it may have certain advantages compared to non-polymerised coagulants, as discussed in more detail in Chapter 3.2.1. In order to obtain more information about the performance of PACl in relation to other coagulants a small experimental series was set up, comparing PACl with non-polymerised AlCl<sub>3</sub>. The AlCl<sub>3</sub> used was similar to commercially available products. In this case however, it was obtained from Kemira Chemicals, AS and is normally used as base product for PACl production. As PACl, PAX-18 was used (Kemira Chemicals, AS). PAX-18 has a relative basicity of 42%, compared to 0% for AlCl<sub>3</sub>.

In three replicates, the two pre-treatment setups using tank and inline coagulation were compared. The tank configuration used has been previously described above. The inline configuration chosen consisted of a static mixer and a subsequent pipe flocculator having a HRT of 0.8 s and a G-value of 1000 s<sup>-1</sup>. The coagulant dosage was set to 3 mg Al/L at a pH of 6. Filtration conditions and the analogue raw water characteristics were otherwise identical with conditions described in the previous chapter.

Irreversible fouling was found to be more significant with AlCl<sub>3</sub>. As shown in Figure 7.4, irreversible fouling was 8 times higher for both pre-treatment configurations, ranging from 16 to 48 mbar/h depending on the setup. PACl caused only 2 mbar/h of irreversible fouling with the tank coagulation and 6 mbar/h with the inline setup respectively. The differences in reversible fouling were smaller for the two coagulants. While it was 20 mbar/h higher for AlCl<sub>3</sub> compared to PACl using the tank setup, PACl produced a higher reversible fouling with the inline configuration. DOC and colour removal were almost identical for both coagulants and independent from the setup, as

shown in Figure 7.5 a). DOC removal was at 52% and colour was removed by 82%. Both fouling and NOM removal levels measured agree well with earlier findings. The residual metal levels were in the same order of magnitude, with the exception that  $\text{AlCl}_3$  showed a higher residual metal when applied together with the inline coagulation pre-treatment, exceeding the limiting value of  $150 \mu\text{g Me/L}$ .

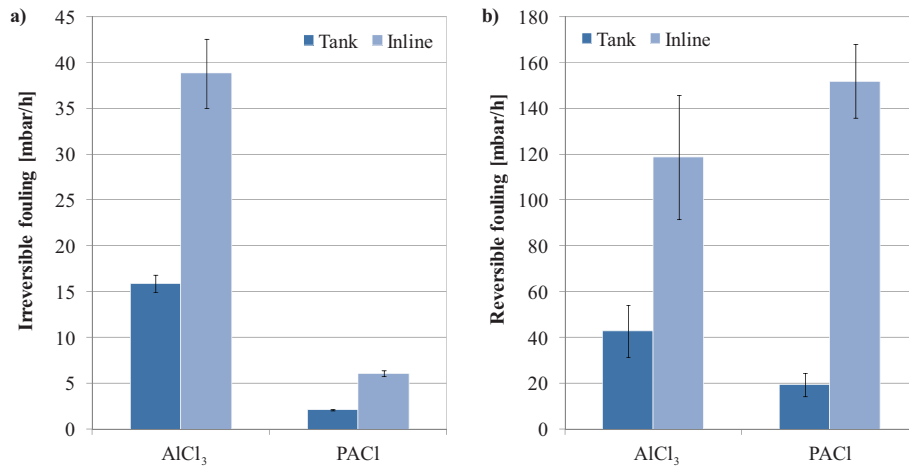

Figure 7.4: Irreversible and reversible membrane fouling in dependence on coagulant type and pre-treatment setup

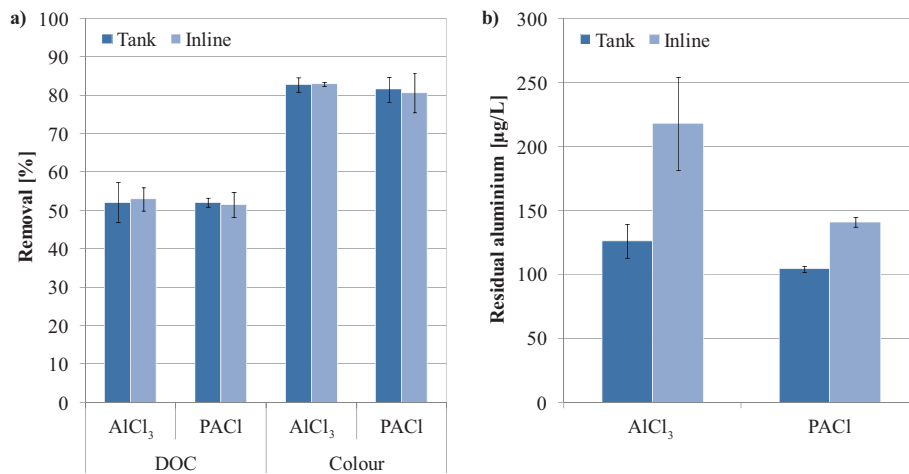

Figure 7.5: NOM removal and residual metal concentration in dependence on coagulant type and pre-treatment setup

In summary, it can be said that in spite of identical NOM removal,  $\text{AlCl}_3$  produced significantly higher irreversible membrane fouling, even in a conservative treatment scheme such as the tank coagulation. This together with the fact that the residual

aluminium concentration is increased at short flocculation times, as applied in the inline pre-treatment configuration, indicate that the coagulation with  $\text{AlCl}_3$  is less efficient compared to PACl. Since DOC removal was identical for both coagulants it was concluded that the increased fouling was caused by insufficient flocculation and not for example by increased fouling of uncoagulated NOM. However, the complete nature of this inefficiency cannot be fully explained based on the limited study done since no additional measurements were carried out such as floc size or zeta potential measurements.

## 7.4 Summary and multivariate analysis of experimental data

Within this research work different experimental series have been carried out, with different research foci and experimental conditions. In order to summarise and compare these extensive data sets, PLS-regression (Partial Least Squares Regression) was applied as will be shown in the following chapter. The aim of the regression analysis was the recognition of dependences between the pre-treatment parameters and the process performance, as well as the identification of what were the most influential parameters. The process performance was measured as DOC removal, residual metal concentration and irreversible and reversible fouling.

### 7.4.1 DOC removal

The data sets of results from the paper publications 1 to 4, the poster publication as well as unpublished data were analysed together by PLS-regression. The unpublished data are results from investigations of inline coagulation with short retention times and high G-values in relation to various coagulant dosages. More details about these data are summarized in Table 7.3. A total of 10 predictors were chosen:

- Two different pre-treatment setups (tank and inline coagulation)
- Three different coagulants ( $\text{FeCl}_3$ , PACl and  $\text{AlCl}_3$ )
- Filtration flux
- Coagulation parameters (flocculation time, G-value, specific molar dosage, pH)

The pre-treatment setups and the different coagulants were also introduced as category variables into the calculations. If a pre-treatment or coagulant was present in an experiment, they were assigned with the level "1". If a factor was not present, it was coded level "0". Besides that, coagulation conditions were directly included in the model with absolute values. This approach may be seen as redundant since coagulation may be overrepresented in the model since predictors for the pre-treatment setup as well as the coagulation conditions were included. This has been done since it could not be

assured that the absolute coagulation variables such as coagulant dose and pH sufficiently describe all the differences between the varying pre-treatment setups. A model with 3 principal components was used. As starting point, all 160 data sets were included in the calculations. 5 of the sets were identified as outliers and excluded from the calculations.

Table 7.3: Summary of unpublished data included into the regression analysis

| Varied parameter            | Value range   |
|-----------------------------|---|
| Pre-treatment configuration | Tank and inline coagulation with static mixing followed by pipe flocculation with HRT of 0 and 0.8 s and a G of $1000 \text{ s}^{-1}$ |
| Filtration parameters       | 250 L/(m <sup>2</sup> h) flux, backwash every 60 minutes  |
| Coagulation                 | PACl with dosages of 1.0, 2.6 and 4.4 mg Al/L, pH 6   |
| Experiments                 | Duplicates, operation for 48h, $n_{\text{total}} = 12$  |
| Raw water                   | Average DOC of 6.6 mg/L and colour of 47 mg Pt/L  |

Validation showed that the principle component (PC) 3 contained most of the information. The regression with 10 predictors explained 77% of the variation in the data. The weighted regression coefficients are shown in Figure 7.6. As can be seen, the coagulation parameters G-value, coagulant dosage and pH value clearly dominate. All other variables have only a minor influence on the DOC removal, and their elimination from the model did not lead to a large drop in explainable variance. G-value, specific molar dosage and pH alone still explained 70% of the total variance in the data. The significance of coagulant dosage and pH for DOC removal are not surprising, since these parameters directly influence the dominant coagulation mechanisms and the way NOM is actually captured by coagulation.

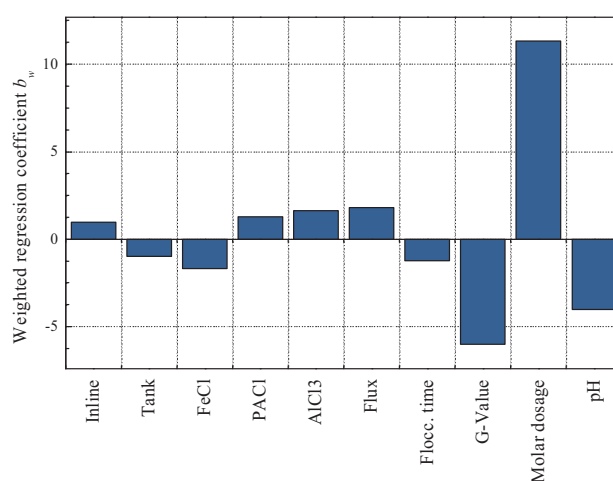

Figure 7.6: Relative influence of predictors on the DOC removal. Summary of all data sets ( $R^2 = 0.77$ ,  $n = 155$ ).



All experiments investigating the dependence of NOM removal in dependence on pH and dose clearly showed an increased removal with decreasing pH and increasing coagulant dosage. However, a pH optimum for each coagulant was identified, and below or above that optimum DOC removal was less efficient. This is shown for example for PACl in Figure A-1 (p. 229). More DOC is removed with increasing coagulant dosage, but with lower efficiency due to diminishing marginal utility. As shown in Figure A-2 for all experimental data obtained with a coagulation pH of 6, there is a linear relationship between coagulant dosage and DOC removal. However, with increasing dosage the amount additional DOC removal decreases. Ultimately, there will be a certain level of DOC which may not be removed by coagulation. It was further speculated that the negative influence of high G-values on the DOC removal may be explained by hindered flocculation by extremely high shear forces in the system. However, as for example seen in Chapter 7.3, this should have no influence on the DOC removal. Analysis of the data sets which directly compare different G-values did not give more information about that, as for example shown in Figure 7.7. There, a regression analysis is presented based on the data set used in Publication 4, together with the data set summarized in Table 7.3. From Figure 7.7 it is clear that DOC removal is only dependent on coagulant dosage, not G-value or flocculation time, as may be suggested by Figure 7.6. Nevertheless, the influence of the G-value may be larger but not more relevant at conditions where coagulant is under-dosed. Investigating coagulation only at a dose of 1 mg Al/L, the weighted regression coefficient for the G-value increased up to 1.3.

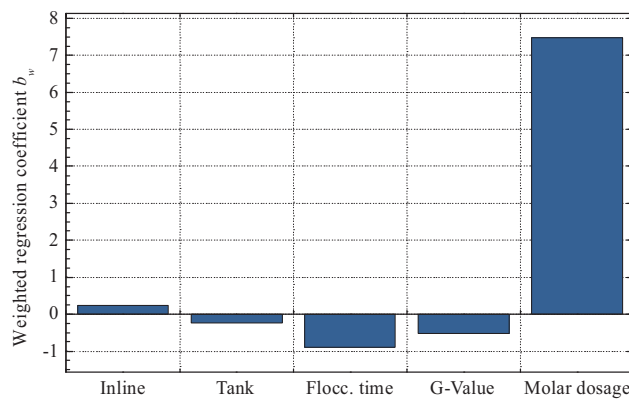

Figure 7.7: Relative influence of predictors on the DOC removal by PACl, comparing inline and tank pre-treatment and varying the flocculation time from 0 to 1260 s, the G-value from 4 to 1000 s<sup>-1</sup> and the coagulant dosage from 0.0063 to 0.024 mM Al per mg of DOC (based on Publication 4 and unpublished data,  $R^2 = 0.86$ ,  $n = 79$ ).

Based on the data used in Figure 7.7, a simple linear regression of just the coagulant dose and the DOC removal showed a correlation of 96%. In order to visualise this, the real experimental data are plotted in Figure 7.8. The DOC removal can be explained to a large extent just by the coagulant dosage, in spite of huge differences in flocculation time and G-value. However, at very short flocculation times the DOC removal is marginally lower. Thus, flocculation time may have some minor influence. If a coagulated system is given a couple of seconds in order to ensure completion of coagulation reactions, the influence of G and t are decreasing and other coagulation parameters such as coagulant dosage and pH are crucial for determining the level of DOC removal.

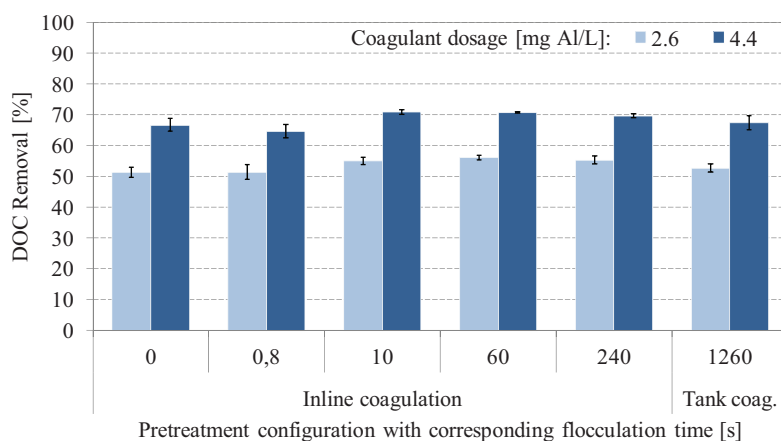

Figure 7.8: Influence of flocculation time on DOC removal ( $n_{\text{total}} = 61$ , pH = 6, flocculation G-values are varying from 12 to 1000).

Further investigation of the data sets submitted to PLS regression revealed the origin of the strong influence of the G-value presented in Figure 7.6. Testing each single data set did not show any noticeable effects. However, when reviewing the data again, it was noticed that the influence of the G-value was removed from the model by excluding the data presented in Publication 1. As a result, an above average DOC removal was achieved by tank coagulation using rather low G-values. Reasons for this enhanced removal can be only speculated. One possibility may be a higher Al to DOC ratio for these trials, since the raw water had a lower DOC compared to the other experiments.

#### 7.4.2 Residual metal

Regression analysis of all data sets with regard to residual metal concentration revealed some difficulties with outlying data. The values higher than 1000  $\mu\text{g/L}$  obtained for low pH values in Publication 1 did not fit into the linear context of the model. These values were therefore removed. The resulting model explained 75% of the variance contained

in the data. The most influential factor was found to be the coagulation pH, showing a strong negative correlation with the residual metal concentration (Figure 7.9). It is hence crucial to control the coagulation pH in order to obtain low residual metal concentrations. Furthermore, the choice of coagulant had a clear influence, indicating a disadvantage for FeCl and an advantage for PACl. The negative evaluation of FeCl is most like originating from the high residual metal concentrations obtained at all conditions investigated in Publication 2. In these experiments the average residual metal concentration was considerably above the legal limit, even at high pH of 6.5. This may be attributed to the insufficient coagulation at the chosen experimental conditions. The HRT in the flocculation was with a maximum of 30s very short and the application of the membrane feeding pump as rapid mixer may have not ensured the necessary mixing intensity. Another indication for insufficient coagulation was the high observed fouling rates in all experiments in that study.

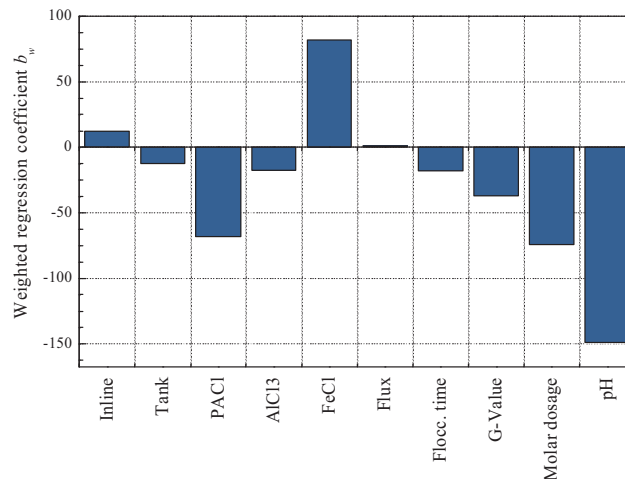

Figure 7.9: Relative influence of predictors on the residual metal concentration. Summary of all data sets ( $R^2 = 0.75$ ,  $n = 136$ ).

Generally, the increased flocculation time leads to reduced residual metal concentrations, as visualised in Figure 7.10. As shown, the residual aluminium concentration is shown in dependence on the flocculation time, the pre-treatment configuration and the PACl dosage, based on results from publication 4 and unpublished data. At a flocculation time of 10 s the residual metal concentration is elevated and always above the legal limit of  $150 \mu\text{g/L}$ . With increasing flocculation time the metal residues are declining and already after 60 s of flocculation concentrations below the legal limit are attainable at a coagulant dosage of  $4.4 \text{ mg AL/L}$ . The lowest average concentrations can be found for very long flocculation times in combination with the tank coagulation pre-treatment. These

findings indicate that sufficient flocculation time is needed in order to minimise the metal residues in the permeate. Additional flocculation time ensures a higher degree of flocculation. However, this has no influence on the amount of NOM removal. The results shown in Figure 7.10 further suggest a relationship between the coagulant dosage and the residual metal concentration.

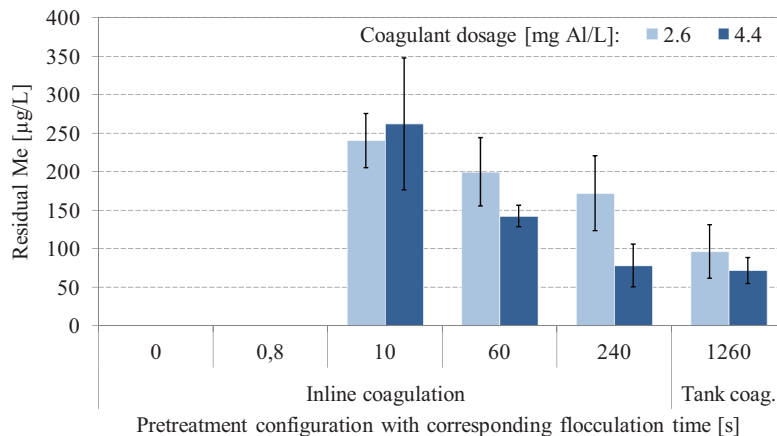

Figure 7.10: Influence of flocculation time on the residual metal concentration ( $n_{\text{total}} = 57$ ,  $\text{pH} = 6$ , flocculation G-values are varying from 12 to 1000).

As previously indicated, another influential parameter was found to be the coagulant dosage, where higher dosages lead to reduced residual metal concentrations. As can be seen in Figure 7.11, notably higher residual metal concentrations are found at low coagulant dosages. Under-dosing of coagulant has to be thus avoided since not only low NOM removal but significant membrane fouling may occur. This corresponds well with the literature published to date. Jekel and Heinzmann (1989) reported for example that at low aluminium dosages excessively high aluminium residuals can be induced by surface complexation. Al dosages from at least 0.4 to 0.5 mg AL per mg DOC are necessary in order to avoid high residual metal concentrations. Finally, also the G-value seems to have some influence, where more intense mixing supports low residual metal concentrations. This may be explained by the simple fact that more mixing increases the efficiency of coagulation and flocculation reactions.

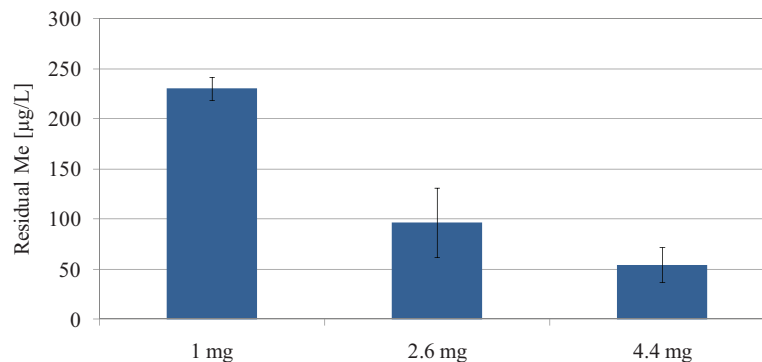

Figure 7.11: Irreversible membrane fouling in dependence on the PACl dosage (tank coagulation pre-treatment, pH = 6, based on unpublished data)

### 7.4.3 Irreversible fouling

In the analysis of the membrane fouling no results from Publication 3 are included, since it was not monitored in these experiments. Furthermore, only data for PACl were available from Publication 1, none for coagulation with FeCl. Comparing all obtained results, the irreversible fouling was found to be the most difficult parameter to describe by PLS regression. It correlated only poorly with the predicting process parameters. Especially the fouling rates obtained in Publication 2, using FeCl as coagulant and operation at fluxes of 223 L/(m<sup>2</sup> h), were exceptionally high and totally out of the context. A regression model based on all data showed thus only poor correlation and explained only 46% of the variance. The most influential factors affecting the irreversible fouling were the three applied coagulants, where PACl had a strong negative weighted regression coefficient and both non-polymerised coagulants a strongly positive one. In order to improve the model and include as much information as possible at the same time, two different models were tested, one totally excluding the data from Publication 2, Publication 3 and the second one, only excluding the results obtained at higher fluxes. Naturally, the revised models showed different results for the coagulant evaluation. Both models had rather high degrees of correlation of above 75% and the results found for the remaining factors were quite similar. It was concluded that the second model, containing only fouling data for FeCl which were obtained at low filtration fluxes, was providing distorted information with regards to the performance of FeCl. Thus, it was decided to exclude the data from Publication 2 from the calculations. The weighted regression coefficients for the revised model are shown in Figure 7.12.

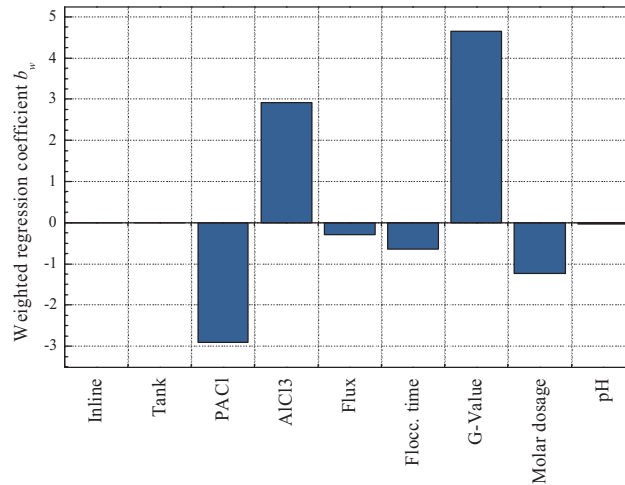

Figure 7.12: Relative influence of predictors on the irreversible fouling. Summary of data from the publications 1 and 4 and unpublished data ( $R^2 = 0.77$ ,  $n = 92$ ).

As already mentioned, the different coagulants were among the strongest predictors, together with the G-value. The highly superior performance of pre-polymerised coagulants corresponds very well with the previously present results, for example in Chapter 7.3. In contrast to regression results obtained for DOC removal, an increasing G-value leads also to higher irreversible fouling. This may have been caused by significantly smaller particles created in the flocculation process compared to conditions at lower shear. Under such conditions the deposited material on the membrane may have formed a fouling layer with reduced permeability. This then may have led to increased irreversible fouling. This hypothesis is supported by the finding that also the reversible fouling is directly proportional related with the G-value, as discussed in the next chapter. However, this was not directly measured and is thus a plausible interpretation of the data. On the other hand, a minimum of shear force is necessary in order to achieve efficient coagulation and flocculation, as for examples shown in Publication 4.

Another important predictor for irreversible fouling was the coagulant dosage. Increased dosing leads to decreased irreversible fouling. Eventual situations with under-dosed coagulant consequently not just lead to higher residual metal concentrations, as shown in the previous chapter, but also aggravate irreversible membrane fouling. This phenomenon is visualised in Figure 7.13, where the irreversible membrane fouling is shown in dependence of different coagulation conditions. The results presented were obtained with the tank pre-treatment configuration and are part of the already mentioned unpublished data set, summarised in Table 7.3. PACl was used as coagulant. While at

an intermediate coagulant dosage the irreversible fouling is already around 5 times higher compared to the optimum, it is 30 times higher if insufficient coagulant is dosed and 2.5 times higher compared to zero coagulant dosage.

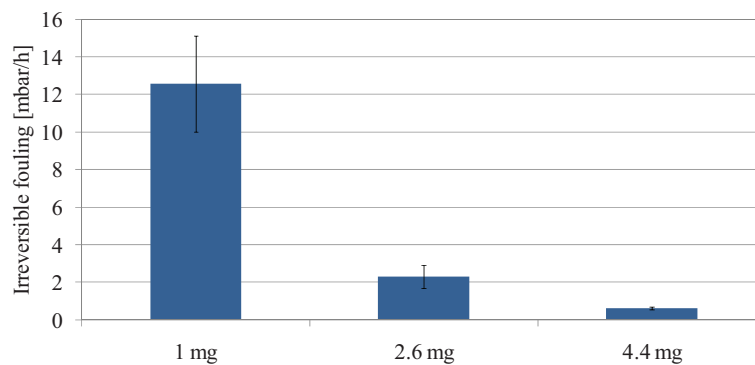

Figure 7.13: Irreversible membrane fouling in dependence on the PACl dosage (tank coagulation pre-treatment, pH = 6, based on unpublished data)

According to the regression results flocculation time is important, but only at small order of magnitude. This can be possibly interpreted in a way that as soon as a certain threshold is exceeded, flocculation time becomes less important and a further increase does not lead to additional fouling decrease. Other parameters become significant, such as the G-value and coagulant dosage. This threshold may vary with operating parameters, raw water conditions and surely for different coagulants. In the performed experiments this threshold was found to be between 10 and 60 seconds for PACl, as shown in Figure 7.14. This figure is again based on combined data from Publication 4 and the unpublished data set. As can be seen, irreversible fouling is relatively high at short flocculation times, but constantly low at times greater than 60 seconds, independently from the G-value and other parameters. Here may also be the reason why no significant difference was shown between the inline and tank pre-treatment configuration in Figure 7.12, since similarly low fouling rates are obtainable with both configurations at a variety of conditions.

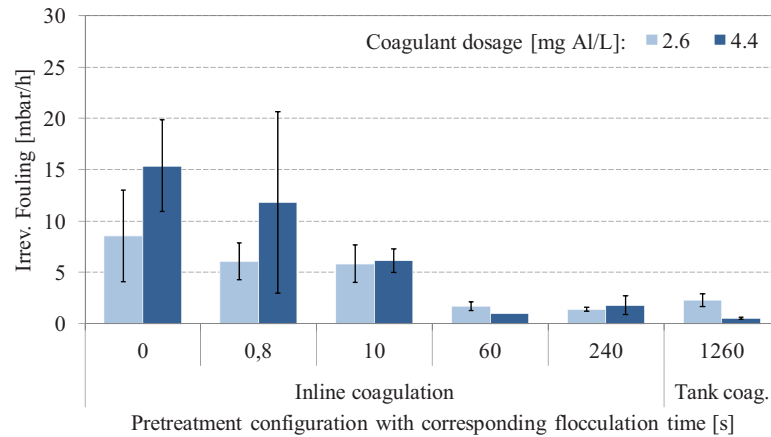

Figure 7.14: Influence of flocculation time on the irreversible fouling ( $n_{\text{total}} = 61$ , pH = 6, flocculation G-values are varying from 12 to 1000).

Filtration flux does not seem to have a major influence. This is most likely due to the fact that low irreversible fouling was obtainable for all tested fluxes and depended only on the coagulation and flocculation conditions chosen. It was further expected that pH may have an influence on the irreversible fouling, since it directly affects the surface charge of the membrane. If the pH of operation is below the PZC of a membrane material the surface will be positively charged and negatively charged NOM may adsorb to a greater extent than at higher pH values. However, the observed effects were rather small or contradictive in this research work. In Publication 1 irreversible fouling for coagulation with PACl was highest at pH values optimal for DOC removal and it was thus concluded that this may be connected to the removal of DOC. In contrast to that, in Publication 2, where inline coagulation with PACl was applied, the pH had only a strong influence at the higher tested operating flux and a pH of 5.5. Based on the results presented in 6.5, no clear dependence of the irreversible fouling on the pH was seen, but a small tendency that fouling was higher at higher pH values. From the results in Publication 1 and Publication 5 it is evident however, that other factors such as coagulant dosage seem to have a higher influence on the reversible fouling than the pH. In contrast to that, many studies have shown increased irreversible fouling at lower pH values (Lerch et al., 2005b; Machenbach, 2007). This behaviour is explained by a lower floc size at such conditions, forming a less porous fouling layer with a gel like consistency.

#### 7.4.4 Reversible fouling

Similar to the irreversible fouling analysis, a regression of all experimental data resulted in a model with rather poor correlation. After analysis two distinct groups of data could



be identified, depending on the applied pre-treatment configuration. In all experiments carried out with tank coagulation a significantly lower reversible fouling was observed. This can be clearly seen from Figure 7.15. Thus, the tank coagulation pre-treatment clearly has an exceptional position with regards to reversible fouling.

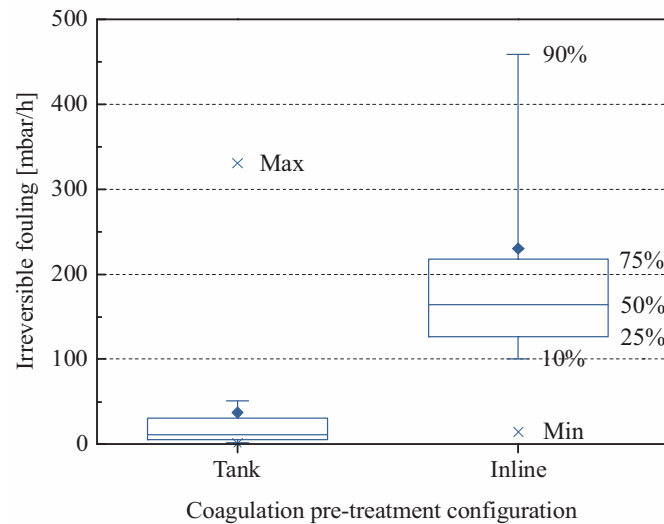

Figure 7.15: Box chart of the reversible fouling distribution in dependence on the coagulation pre-treatment configuration (upper limit of Y-axis set to 500 for increased clarity, diamonds are representing the data mean, maximum value for inline coagulation at 1487,  $n_{\text{tank}} = 25$ ,  $n_{\text{inline}} = 93$ )

The experimental data clearly show that the reversible fouling is dependent on the flocculation time, as similarly done for DOC removal (Figure 7.8) and irreversible fouling (Figure 7.14). While the DOC removal did not depend on the setup and flocculation time, the irreversible fouling was generally low with tank coagulation pre-treatment. However, also with inline coagulation comparably low irreversible fouling rates were achievable at extended flocculation times. In contrast, the reversible fouling with inline coagulation was not reducible to levels observed with tank coagulation (Figure 7.16).

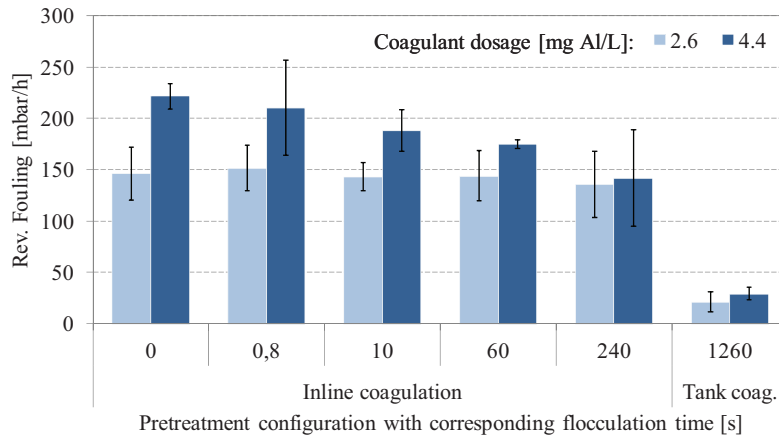

Figure 7.16: Influence of flocculation time on the reversible fouling ( $n_{\text{total}} = 61$ ,  $\text{pH} = 6$ , flocculation G-values are varying from 12 to 1000).

This behaviour may be explainable by the significantly longer flocculation time of 20 minutes. At such long times together with low G-values, very large macro flocs were formed in the flocculation tanks. This was verified with the PDA 2000 measurements, which showed an up to ten times higher flocculation index in the slow mixing tank compared to inline coagulation. This is shown in Figure 7.17 for a PAC1 dosage of 3 mg Al/L. The inline coagulation pre-treatment was set up with a G-value of  $31 \text{ s}^{-1}$ . The tank configuration was operated as usual, with a HRT of 20 minutes and an estimated G-value in the slow mixing stage of  $100 \text{ s}^{-1}$ . The flocculation index was measured directly after the pipe flocculator which was located directly before the membrane module. In the case of the tank configuration, the flocculation index was measured in the slow mixing tank and directly before the membrane. The data shown are again part of the data set from Publication 4 and unpublished data. As can be seen, the flocculation index is not significantly changed for inline coagulation with a flocculation time of 10 and 60 seconds. After 240 seconds a clear floc growth can be observed. This growth is small compared to floc sizes found in the slow mixing stage of the tank coagulation. However, once these flocs pass the membrane feeding pump and are about to enter the membrane they are totally broken and may have a size similar to flocs produced by inline coagulation. In spite of that, reversible fouling is significantly lower with the tank configuration. Thus, the size itself cannot be the reason for the different behaviour and must be found in other floc properties. The re-growth capability of flocs created with metal coagulants strongly depends on the coagulation mechanism. If charge neutralisation is dominating flocs show a high re-growth potential (Kim et al., 2007; Yu et al., 2010). From metal speciation diagrams it is not clearly derivable whether charge neutralisation or sweep flocculation is dominating at the selected conditions tested. Most of these diagrams are only valid for  $25^\circ\text{C}$ . However, due to the

fact that travel time from the membrane feeding pump to the membrane entrance is very short and in the range of seconds, reasonable re-growth may not occur before the particles enter the membrane. Nevertheless, this may happen within the membrane channels where particles are concentrated and thus have the opportunity to reaggregate. Another reason may be found in the properties of the fractured floc fragments. These are possibly quite strong structured and once deposited on the membrane surface, form a easily permeable and little compressible layer.

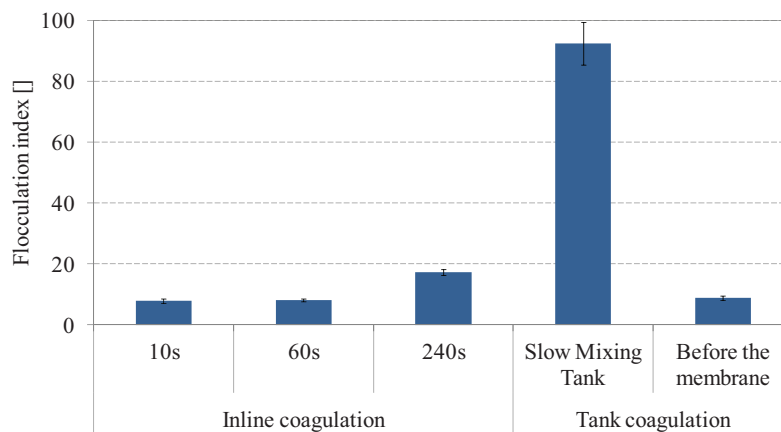

Figure 7.17: State of aggregation shown as flocculation index in dependence on pre-treatment configuration and flocculation time (coagulation with 3 mg Al/L, G-value in inline configuration was  $31 \text{ s}^{-1}$ ,  $n = 2$ )

In spite of the difficulties with the large data variation, PLS-regression was carried out also for the reversible fouling. The results are shown in Figure 7.18. The obtained model described only 63% of the data variation and all predictors included in the model seem to have relevance, concluded from the weighted regression coefficients. It should be noted that the regression quality was rather low and absolute conclusions cannot be drawn from the values of the weighted regression coefficients. Nevertheless, statements about the general influence of a predictor on the reversible fouling are possible. Surprisingly, Figure 7.18 does not show a clear supremacy of the tank pre-treatment configuration compared to the inline setup, as explained at the beginning of this chapter. However, the positive influence of an increased flocculation time was found by the model.

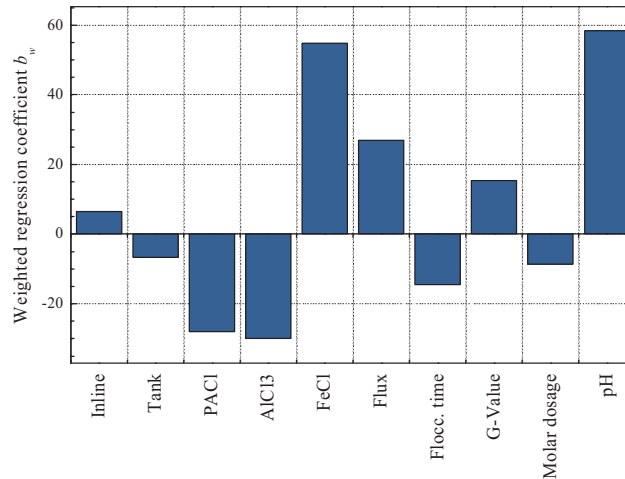

Figure 7.18: Relative influence of predictors on the reversible fouling. Summary of data from the publications 1, 2 and 4 and unpublished data ( $R^2 = 0.64$ ,  $n = 112$ ).

The pH value and FeCl are the parameters with a major influence on the irreversible fouling, which is directly proportional. The source of the influence for both parameters can be clearly found in Publication 2. The amount of reversible fouling observed in this study was significantly higher compared to the others. This explains why FeCl is evaluated so unfavourably. The poor performance of FeCl was also seen for the irreversible fouling, hence it is again concluded that the operating conditions chosen in the experiments presented in that publication have been unfavourable since membrane fouling was not reduced but actually drastically increased by coagulation pre-treatment. In addition to the high level of reversible fouling observed with FeCl, a strong relationship with the pH was found. With increasing pH, the reversible fouling increased dramatically by an order of magnitude (Figure 7.19). This behaviour can only be explained hypothetically at the moment. At a constant dose of 6 mg Fe/L, the dominating coagulation mechanism may change from adsorption-destabilisation to a situation where sweep flocculation takes over. This shift happens in the pH-region between 6.0 and 6.5 (Johnson and Amirtharajah, 1983; Bottero and Bersillon, 1989). However, the reversible fouling is already on a high level at a pH of 5.5 and even higher at a pH of 6.5. The minimum of reversible fouling occurs simultaneously with the highest DOC removal at a pH of 4.5. At this condition charge neutralisation is the dominating coagulation mechanism, which is generally very fast and in the range of milliseconds while formation and aggregation of amorphous  $Me(OH)_3$  needs additional time (Hendricks, 2006). Since the flocculation times were very short, 10 and 30 s, the charge neutralisation reactions may have had an advantage and faster form aggregates which form a fouling layer with less resistance. A similar dependence was also found for PACl, as shown by Lerch et al. (2005b) and in Publication 5.

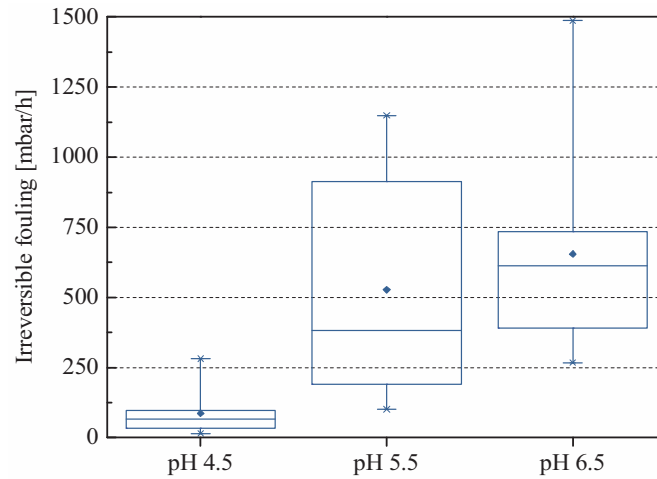

Figure 7.19: Box chart of the reversible fouling after inline coagulation with FeCl (6 mg Fe/L) in dependence on the pH (based on Publication 2, n = 24)

In contrast to presented findings, coagulation with PACl and tank pre-treatment did not show such a strong dependency on the coagulation pH (Publication 1). No clear pattern was found in that case and the reversible fouling was generally considerably lower. This finding leads to the conclusion that if more suitable operating conditions are applied (i.e. longer retention times), most likely less irreversible fouling would be observed and the pH influence would be reduced. However, this has not explicitly been tested, but initial experiments using FeCl in combination with tank coagulation pre-treatment pointed in that direction.

As a consequence of the poor model correlation and the strong influence of the inline coagulation experiments with FeCl, the regression analysis was repeated without these data. The quality of the model increased as now 78% of the variation in the data was explained. In contrast to before, the pH value does not longer have a strong influence on the reversible fouling. The most influential parameters are now the pre-treatment setup, the flocculation time, the filtration flux and the coagulant dosage, as shown in Figure 7.20.

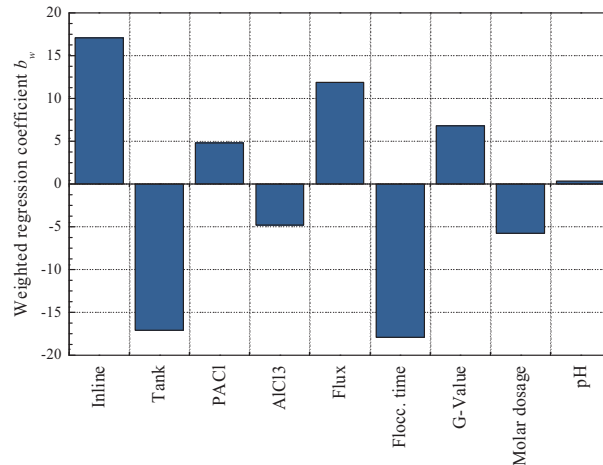

Figure 7.20: Relative influence of predictors on the reversible fouling. Summary of data from the publications 1 and 4 and unpublished data ( $R^2 = 77.6\%$ ,  $n = 91$ ).

In the revised model, the coagulant dosage was found to have an indirectly proportional effect on the reversible fouling. Thus, higher coagulant dosages may decrease the reversible fouling. However, this is only true for situations switching from under-dosing conditions to conditions with sufficient amount of coagulant, as shown in Figure 7.21. As similarly shown for irreversible fouling in Figure 7.13, small coagulant dosages lead to exceptionally high reversible fouling. Coagulation is not sufficient and incomplete. With increasing dosage the reversible fouling is reduced. If the coagulant dosage was further increased above a certain threshold the reversible fouling starts to increase again, most likely due to improved removal of NOM, as for example observed in Publication 1, or augmented formation of metal hydroxides. Thus, the coagulant dose may have two effects, one beneficial at low dosages, but also a detrimental one with increasing dosage, since more material is going to be deposited on the membrane as a consequence.

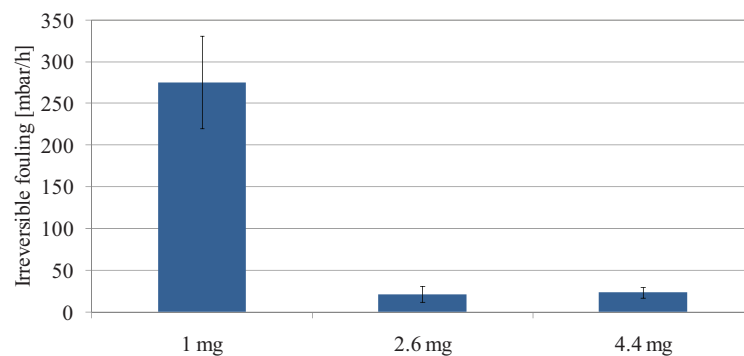

Figure 7.21: Reversible membrane fouling in dependence on the PACl dosage (tank coagulation pre-treatment, pH = 6, based on unpublished data)

Finally, filtration flux and G-value seem to have a direct proportional influence on the reversible fouling. Since in all experiments with flux variations the backwash interval was not adjusted to the higher filtration volume, more water was treated at higher fluxes. Thus, more material was deposited on the membrane surface within a filtration cycle, which increased the filtration resistance and consequently the reversible fouling. The G-value may have different influences on the reversible fouling, depending on its level. If the G-value is high ( $> 300 \text{ s}^{-1}$ ), small flocs sizes are achieved, leading probably to a denser cake layer with higher hydraulic resistance. This behaviour was captured in Figure 7.18 and noticed in the Publications 2 and 4 (Chapters 6.2 and 6.4). As can be seen from Figure 7.22, the reversible fouling at a G-value of  $300 \text{ s}^{-1}$  is higher compared to the fouling at a G of  $60 \text{ s}^{-1}$  independent of the pH value. The data presented in the diagram are taken from Publication 2, where inline coagulation with FeCl was investigated. In contrast, the results presented in Publication 4, where the influence of G-values in the range from 4 to 3000 was investigated using the inline coagulation setup together with PACl, appear to point in the opposite direction. An increase of the shear gradient decreased the reversible fouling. This effect was especially observable at flocculation times of 60 s and above and at the higher investigated coagulant dose of  $4.4 \text{ mg Al/L}$ . These results indicate that a minimum of shear is necessary in order to have efficient flocculation. However, it was also seen that a too high shear may have detrimental effects. At a coagulant dosage of  $4.4 \text{ mg Al/L}$  and at a G-value of  $300 \text{ s}^{-1}$ , the reversible fouling was higher compared to conditions with lower G-values of 98 and  $31 \text{ s}^{-1}$ .

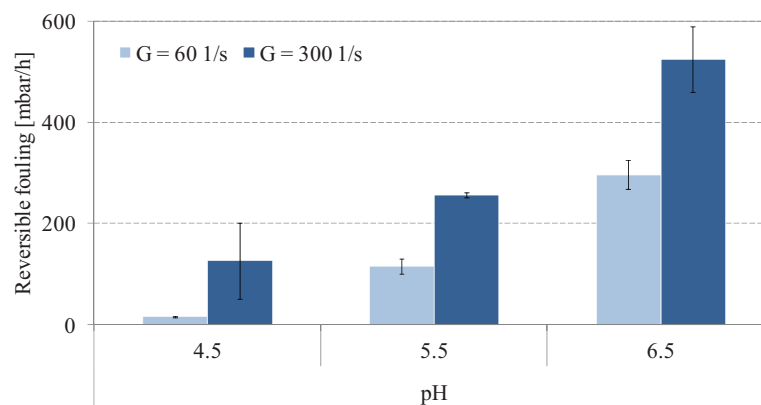

Figure 7.22: Reversible fouling after inline coagulation with FeCl in dependence on the G-value and pH (based on data from Publication 2 for a filtration flux of  $143 \text{ L}/(\text{m}^2 \text{ h})$ ,  $n_{\text{total}} = 12$ )

In summary, it can be said that the irreversible membrane fouling was significantly lower if the tank pre-treatment configuration was applied, compared to the inline setup. This may have its origin in the extended flocculation time in the tanks. More likely is

the fact that the particles resulting from the destruction of the flocs grown in the flocculation tanks in the membrane feeding pump are much smaller than before destruction, but may be also stronger and thus form a fouling layer with a higher permeability. Furthermore, floc re-growth may play a role. Furthermore, underdosing of coagulant leads to massive reversible fouling. Increased flocculation time leads to decreased reversible fouling. For the mixing intensity during flocculation an optimal range was found where too low G-values inhibit efficient flocculation due to insufficient collision frequencies and too high values limit the aggregate size which may have led to a denser cake. In both cases the reversible fouling was elevated. The influence of the pH value seems to depend on the pre-treatment configuration. While with inline coagulation the reversible fouling significantly increased with increasing pH, this behaviour was not seen with the tank configuration.



## Conclusions

### 8.1 Revising hypotheses

Based on the results presented in the previous Chapters 6 and 7, the hypotheses presented in Chapter 2.4 are evaluated in the following.

**A) Without coagulation NOM removal by microfiltration membranes is poor, with a potential of rapid membrane fouling by the organic matter.**

As presented in Chapter 7.1, no significant amount of NOM is removed by the microfiltration membrane. Additionally, membrane fouling is significantly higher compared to conditions with optimised coagulation pre-treatment. Thus, coagulation is suitable for the reduction of membrane fouling by NOM. However, if unfavourable coagulation conditions are chosen, membrane fouling can be considerably higher compared to conditions without coagulation. Hypothesis A is thus confirmed.

**B) Coagulation/flocculation pre-treatment is a requisite with membrane micro-filtration for sufficient NOM removal when treating raw water with high NOM content and low turbidity.**

Coagulation pre-treatment increased the NOM removal dramatically. While without any coagulation only 0.6 % of DOC was retained by the membrane, with removal increasing to 13 to 84 %, depending on the selected coagulation conditions. Furthermore, NOM removal generally improved with decreasing pH and increasing coagulant dosage. Depending on the base metal in the coagulant, different pH-regions for optimal NOM removal were identified. The optimum for aluminium based coagulants was found to be between a pH of 5.5 to 6.0, whereas iron based coagulants showed best NOM removal

at pH-values of 4.5 and below. However, at such low pH-values high residual metal concentrations were observed. Hypothesis B is confirmed.

**C) Due to the separation properties and mechanisms by microfiltration membranes very small particulates can be removed, thereby reducing the amount of flocculation necessary for efficient particle removal. However, there is a minimum of flocculation necessary in order to reduce membrane fouling by colloidal material.**

It was found that the removal of NOM did not depend on the flocculation time, only on the coagulation pH and the coagulant dosage. Experiments without any flocculation, where the coagulant was dosed in front of a static mixer which was mounted directly at the inlet of the membrane module, showed basically the same NOM removal rates as the process configurations with extensive flocculation. Under such conditions, no real flocs can be formed before the water enters the membrane as the time is too short. In the membrane channel flocculation is possible, since the flow conditions are more moderate, depending on the location of the membrane channel in the module and the distance from the inlet. Nevertheless, the formed coagulant-NOM aggregates can be retained by the membrane. The membrane fouling under such conditions, both irreversible and reversible, is dramatically high. Thus, although good NOM removal can be achieved without any flocculation, it is necessary in order to reduce the membrane fouling. Based on the results in this study, flocculation times of at least 60 s are necessary coupled with G-values in the range from 30 to 98 s<sup>-1</sup>. Longer flocculation times may further reduce the reversible fouling and the residual metal concentration, but not the irreversible fouling. However, this may not be practical since the amount of floor space needed for the flocculation stage thus increases. If the shear gradient in the flocculation is too small no efficient particle aggregation is achieved. If it is too high, small flocs are formed which leads to deposition layers on the membrane surface with a lower permeability. The properties of the formed particles may be especially important for microfiltration. While small particles still lead to cake development on ultrafiltration membranes, the same particles may block the pores of a MF membrane.

Different forms of coagulation/flocculation have been investigated, configurations with a rapid and slow mixing tank simulating conventional treatment and inline coagulation followed by pipe flocculation as an alternative approach. In general, both options are suitable pre-treatment designs. Similar results for NOM removal, residual metal concentration and irreversible fouling can be obtained with both alternatives. However, it should be noted that the level of reversible fouling was always higher in experimentation with inline coagulation, in spite of very low irreversible fouling.

Hypothesis C is thus confirmed.

**D) Both, polyaluminium chloride and iron chloride commonly used in drinking water treatment are suitable coagulants. Optimum coagulant dosages are in the same range as those used for conventional treatment processes. However, there is a potential for using lower dosages.**

Both primarily investigated coagulants, PACl and FeCl, are suitable for application in the coagulation pre-treatment, as for example shown in Publication 1. All tested coagulants were able to efficiently remove NOM, with a small advantage for the aluminium based coagulants, since generally pH values above the removal optimum for ferric chloride were investigated. However, PACl may have an advantage compared to non-polymerised coagulants even though this was not extensively evaluated. It was shown that non-polymerised coagulants may need more flocculation compared to PACl in order to avoid and reduce the level of membrane fouling, resulting in the need of process designs giving higher flocculation times.

Suitable dosage ranges, combining sufficient NOM removal, low residual metal concentrations and low membrane fouling potential have been identified for PACl. In order to achieve that, a minimum of flocculation together with suitable G-values is necessary as explained under Hypothesis C. Additionally, it is recommended to avoid acidic pH values below 6 in order to avoid high residual metal concentrations. The obtained results clearly show that there is a practical minimum dosage. Besides poor NOM removal, coagulant dosages below this threshold lead to high membrane fouling and residual metal concentrations as summarized in Chapter 7.4. Such behaviour has been observed to be very pronounced at coagulant dosages of 1 mg AL/L ( $\approx 0.16$  mg AL/mg DOC) and less obvious at 2 mg AL/L ( $\approx 0.34$  mg AL/mg DOC). Increase of the coagulant dosage reduces irreversible membrane fouling and residual metal and also increases DOC and colour removal. Reversible fouling, however, starts to increase at higher coagulant dosages. Such effects have been observed at PACl dosages of 2.6 and 4.4 mg AL/L, which correspond to specific dosages of 0.38 and 0.65 mg AL/mg DOC. For the latter dosage the residual metal concentrations were found to be well below the legal limit, while it increased at lower dosages (Publication 4). However, results obtained are partially contradictive since in the initial experiments high residual metal content was found under such conditions (Publication 1), while this was not the case for the other experiments. Thus, the minimum practical dosage which can be recommended based on the findings of this study is 4.4 mg AL/L ( $\approx 0.65$  mg AL/mg DOC). A lower minimum dosage may be possible, as for example suggested in Publication 1 or Publication 5. While 2.6 mg Al/L ( $\approx 0.38$  mg AL/mg DOC) may be too low, since insufficient colour removal was observed and the residual metal concentrations were in the range of the legal limiting, a dosage of 3 mg Al/L ( $\approx 0.58$  mg AL/mg DOC) may be an acceptable value. However, the mentioned experimental series differed in the experimental conditions, either by the coagulation pre-treatment or the membrane

properties, and have to be therefore evaluated with care until more underlying results are available. The identified minimal dosages are in the same range as found for conventional processes. An empirical model developed for enhanced coagulation - contact filtration, based on the treatment of low turbidity and alkalinity water with high colour and DOC (Eikebrokk, 2004), predicts as absolute minimum Al dose of 2.45 mg Al/L for a water with a colour of 50 mg PT/L. The predicted practical minimum dosage is 3.07 mg/L. As explained in Chapter 4.1, the practical minimum dosage is higher than the absolute minimum dosage in order to widen the pH-window where low residual metal concentrations can be achieved. It should be stated that the afore-mentioned model was based on coagulation with aluminium sulphate and the results may therefore not be 100 % comparable to coagulation with PACl. The identified coagulation dosages fit very well with data published by Archer and Singer (2006). They published results from the largest nationwide water quality survey ever conducted in the U.S.A., assessing enhanced coagulation performance for water treatment facilities. Their findings further indicated that coagulation preferentially removes UV-absorbing, aromatic organic carbon.

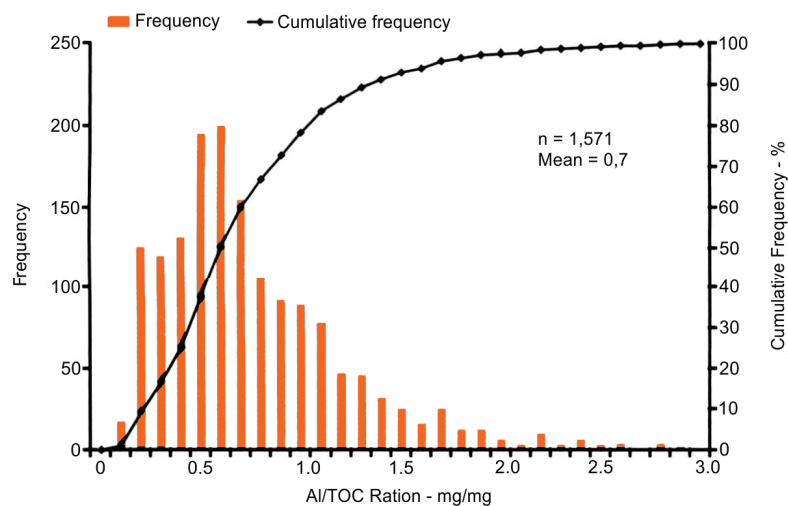

Al - alum, n - number of records, TOC - total organic carbon

Figure 8.1: Frequency distribution plots of aluminium dosage to raw TOC concentration ratios (Archer and Singer, 2006)

For coagulation with FeCl<sub>3</sub>, no satisfying results were obtained in this study. While it has been shown that FeCl<sub>3</sub> can be successfully used for DOC and colour removal in Publication 1, no data regarding membrane fouling were obtained in the experimental series. A second set of experiments investigating inline coagulation with FeCl<sub>3</sub> showed only dissatisfactory results (Publication 2), since unfavourable coagulation and

flocculation conditions were chosen and the membrane performance was poor. Thus, more research is required in order to investigate the potential of FeCl. However, it is assumed that with sufficient coagulation and flocculation, the performance should be comparable to aluminium based coagulants.

In conclusion, the minimum practical coagulant dosages were found to be in the same range as reported for conventional filtration. Lower coagulant dosages are not applicable, since NOM removal will be poor, and the residual metal concentrations high as well as the membrane fouling. Coagulation/flocculation and ceramic microfiltration can be consequently seen as a typical coagulation process. If higher coagulant dosages than necessary are applied, high sludge production and membrane fouling may be a consequence, the latter especially if the flocculation is not optimised. Under such conditions the increased load to the membrane may lead to a higher backwash frequency and the recovery may decrease. Thus, the optimum dose has to be found between a too low or too high level. Furthermore, it is absolutely crucial to optimise the coagulation pre-treatment in order to achieve a sustainable operation. Thus, the first part of Hypothesis D is confirmed, the second part rejected.

**E) If the coagulation is operating in agreement with good operational practise, and thus the criteria for approval as hygienic barrier are met, efficient virus removal is achieved.**

While no MS2-bacteriophages were removed without coagulation, removal ranged from 1 to 8 log units (i.e. no viruses detected in the permeate) if coagulation was applied. Thus, complete virus removal was achievable, however, not always at coagulation conditions giving treated water that comply with demands of the Norwegian regulations. In order to identify the experiments which actually comply with the regulations, the Norwegian limiting values with regards to residual colour, TOC and metal were used, presented in Table 2.2 (page 8). Compliance with these guidance values can be understood as good operating practise and the concerning treatment process can be approved as a hygienic barrier. While at 5 experimental conditions the residual metal concentration was below the limiting value of 150  $\mu\text{g Me/L}$ , only two experiments complied with the demands on residual TOC ( $< 3 \text{ mg C/L}$ ) and colour ( $< 5 \text{ mg Pt/L}$ ). Using inline coagulation with PACl, compliance was achieved with a coagulant dose of 2 mg Al/L at a pH of 5.5 and at a dosage of 4 mg Al/L at pH 6.5. At these conditions a log virus removal of 4.9 and 3.5 respectively was observed. In the other experiments, higher virus removal was measured, but too high residual metal or colour concentrations were also observed. Such removal rates correspond well with other guidelines for hygienic barriers, which require virus removal rates in the range of 3 to 4 log units. Furthermore, they are reasonably higher than the log removal credit of 3 log units, assigned to the process combination coagulation-MF by the Norwegian

national association of water and wastewater works. In spite of elevated NOM concentrations in the raw water sufficient virus removal was possible with simultaneous compliance of guidelines for good operational practise. Therefore, hypothesis E is confirmed.

**F) Due to different flocculation needs for membrane microfiltration and the expected high but sustainable fluxes, the hybrid coagulation / flocculation microfiltration process opens the potential for new and more compact treatment designs and configurations compared to direct filtration and nanofiltration.**

It was clearly demonstrated that ceramic microfiltration together with inline coagulation can be successfully applied at high filtrations fluxes ( $250 \text{ L}/(\text{m}^2 \text{ h})$ ). Such membrane fluxes allow the treatment of the same amount of water with a significantly reduced installed membrane area, compared to nanofiltration or polymeric low-pressure filtration. However, state of the art module design may allow the installation of more membrane area per  $\text{m}^2$  floor space in the case of polymeric membranes. Thus, the resulting footprints of treatment schemes with ceramic or polymeric membranes may be in the same order of magnitude. Compared to conventional filtration, a reduction of the footprint by the factor two has been estimated, assuming a filtration velocity of  $15 \text{ m/h}$  in the rapid filtration and membrane flux of  $250 \text{ L}/(\text{m}^2 \text{ h})$  together with a packing density of  $114 \text{ m}^2$  membrane area per  $\text{m}^2$  of floor space. The membrane packing density calculation was based on the assumption that 48 full scale modules with a membrane area of  $25 \text{ m}^2$  are packed into a rack with a length of  $5.5 \text{ m}$  and a width of  $1.9 \text{ m}$ . It was further shown that compact inline coagulation pre-treatment is a suitable option instead of conventional tank coagulation. However, also inline coagulation with pipe flocculation has a significant floor space demand. If for example a flocculation time of  $60 \text{ s}$  is assumed together with a flux of  $250 \text{ L}/(\text{m}^2 \text{ h})$ , a theoretical pipe flocculator for a membrane rack as described above (48 modules with  $25 \text{ m}^2$  membrane area) needs to have a volume of  $5 \text{ m}^3$ . Hypothesis F is thus confirmed.

**G) Coagulation/flocculation coupled with ceramic microfiltration is very well suited for the treatment of typical Nordic surface waters and can readily compete with conventional processes with respect to treatment efficiency, water quality produced, with the potential of reducing sludge/waste production, energy requirements and overall costs.**

It was demonstrated that coagulation coupled with ceramic microfiltration is indeed a suitable process combination for the treatment of low alkalinity and turbidity waters with a high colour and DOC content. Good NOM removal was achieved, together with low residual metal concentration and controlled membrane fouling. High sustainable

fluxes were also achieved. Sufficient virus removal was demonstrated, in spite of the elevated NOM content in the raw water. However, it was absolutely crucial to optimise coagulation in the pre-treatment. If this was not done, severe membrane fouling, high residual metal concentrations, poor DOC, colour and virus removal, waste of coagulant, reduced recovery and increased chemical demand for membrane cleaning may be the consequence. It has been further demonstrated that without coagulation MF by itself only poorly improves the water quality, since no significant amounts of NOM and viruses are removed.

An extensive comparison with alternative treatment concepts was only partially performed since comparative data are missing, which may be a subject for future work. Thus, issues like sludge production and energy consumption have not been included in this evaluation. However, some considerations regarding possible treatment costs of the presented treatment scheme can be found in Chapter 8.3. It is clear that if high fluxes can be achieved and the WTP is operated close to its design maximum most of the time, the additional investment costs for ceramic membranes may be diminished since less membrane surface would be needed. It is further assumed that since MF with coagulation pre-treatment performs like any normal coagulation process, the sludge production will be in the same range as for direct filtration. However, due to the operational differences the sludge properties may differ significantly which will most likely have implications for its further treatability.

Hypothesis G is thus confirmed. However, pilot trials with real waters under real world conditions should be performed in order to confirm the results found in this work, since natural waters differ from the analogue water used in the laboratory, for example in their alkalinity and hardness.

## 8.2 Suggestions for WTP design

Based on the experiences from this work a scheme for a possible treatment plant was proposed as shown in Figure 8.2. As a first step a pre-filtration is suggested. This pre-treatment is optional and may be used if the raw water turbidity is higher than usual due to the characteristics of the water source. After this, the water is prepared for the coagulation step. If necessary, chemicals should be added for the adjustment of pH and buffer capacity. Then, the coagulant should be added prior to a mixer, followed by a short flocculation. The chosen flocculation time does not have to be equal to the HRT of the actual flocculation step, for example a pipe flocculator. Time for water transport from the mixer to the membrane module may be included in the suggested time interval. The next step suggested is the membrane filtration, followed by dosage of CO<sub>2</sub> in order to increase the uptake of hardness in the subsequent marble or limestone filtration. In addition to hardening the water and increasing its pH, this additional filtration may

remove potentially dissolved metals such as manganese, iron or aluminium. As a last step, the treated water should be disinfected.

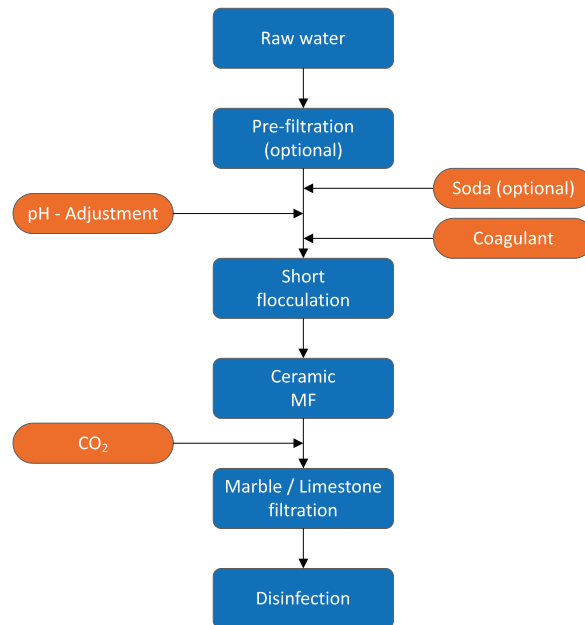

Figure 8.2: Suggested scheme for a WTP with coagulation pre-treatment followed by ceramic MF

The coagulation conditions should be selected on the basis of the result summary in the Chapters 7.4 and 8.1. Thus, a minimum coagulation time of 60 seconds is required. If PACl (PAX-18) is used, a pH of 6 is recommended together with a specific coagulant dosage of 0.65 mg AL per mg DOC. If for some reason higher operational pH values are necessary, higher specific coagulant dosages may be necessary in order to achieve sufficient DOC and colour removal. With regards to the operation of the ceramic membranes, a filtration flux of 250 L/(m<sup>2</sup> h) was found to be suitable. If the organic or particle load is lower than in the experimental conditions tested, even higher fluxes may be possible. The backwash interval of the membrane may strongly depend on the NOM content of the water. The more NOM is contained in the raw water the more often a backwash has to be carried out since more material will be deposited in the membrane channels.

Therefore, in order to improve NOM removal, operation at lower pH-values may be considered. As done for rapid filtration and described in Chapter 4.1.2, the coagulation could be operated at the optimal pH-values for DOC and colour removal. These are in the range of 4.0 to 4.5 for FeCl and between 5.5 to 6.0 for aluminium based coagulants.



This would improve the NOM removal in relation to the coagulant dosage significantly. Elevated residual metal concentrations could be captured in the following marble filtration phase. The material properties of the applied ceramic membranes allow the operation at low pH-values. However, operation at such low pH values was not thoroughly tested in this work and additional operational problems may occur. Most important may be a change in the surface charge of the membrane if the IEP of the membrane material is undercut. In such a case the charge may shift from negative to positive. As a consequence, negatively charged NOM may attach to the membrane surface and irreversibly foul the membrane. It is not clear whether coagulation is able to fully circumvent this behaviour. Furthermore, the floc properties may change in an unfavourable way, leading to higher irreversible and reversible fouling.

### 8.3 Cost considerations

Concluding the investigations, a rough cost estimation for the investigated treatment scheme was made based on different scenarios. The cost calculations are based on the application of state of the art, full scale membrane modules as shown in Figure 4.13, which have an area of 25 m<sup>2</sup> and an assumed life time of 12 years. A summary of the estimated operational parameters is shown in Table 8.1. Costs for sludge disposal are not included in the calculations.

Table 8.1: Assumed operational parameters

| Parameter                          | Unit                 | Values   |
|------------------------------------|----------------------|----------|
| Membrane flux                      | L/(m <sup>2</sup> h) | 50 - 400 |
| Backwash water volume <sup>1</sup> | L/m <sup>2</sup>     | 2.5      |
| Backwash interval                  | h                    | 2        |
| CEB interval                       | h                    | 12       |
| Backwash duration                  | min                  | 0.75     |
| CEB duration                       | min                  | 10       |
| Chemical concentration at CEB      | mg/L                 | 1,000    |
| Coagulant dosage                   | mg/L                 | 4.4      |

<sup>1</sup>Three times higher at CEB

The following cost types were considered: investment costs, reinvestment costs and operating costs. Investment costs are costs that accrue only once, for the construction, acquisition or modernisation of facilities. Not all possible investment costs were included like for example costs for preliminary work (project development, planning, survey etc.) or development costs (provision of infrastructure and services). Only the actual building or construction costs were considered, such as real estate costs, ground excavation, housing, surface pavement, fencing and outdoor facilities. Reinvestment costs accrue if the service life of a component is shorter than the overall service life of the whole WTP and thus has to be replaced, for example for the membranes and the

process and energy technology. Operating costs are investments necessary to ensure daily operation and differ from reinvestment costs, since they are spent for components with a very short service life (below 5 years in this calculation). Operating costs were divided into labour costs, material costs and energy costs. For the service life of the WTP a time of 60 years was assumed, as well as for the building's life span.

The process technology was calculated with a service life of 20 years, the energy technology with 15 years. The ceramic membranes have to be replaced every 12 years. All costs were weighted regarding to their date of accrument, using the present-value method. Furthermore, a capital interest rate of 5% was assumed. A possible future increase of prices was not considered and assumed to be zero.

In the following figures the result of the cost evaluation are shown. Specific treatment costs are presented in dependence on different operational assumptions. Firstly, the influence of the specific membrane cost was investigated. The influence of different assumed specific membrane costs is shown in Figure 8.3. As can be seen, the specific treatment costs increase with increasing membrane price, however, the increase of the price of a  $\text{m}^3$  of treated water is not as drastic as may be expected. A membrane price increase of 5 times increases the treatment costs only by a factor of 1.5. The main reason for that is the long estimated lifetime of the membranes of 12 years. It is also clear that the specific treatment costs drastically decrease with an increasing size of the WTP.

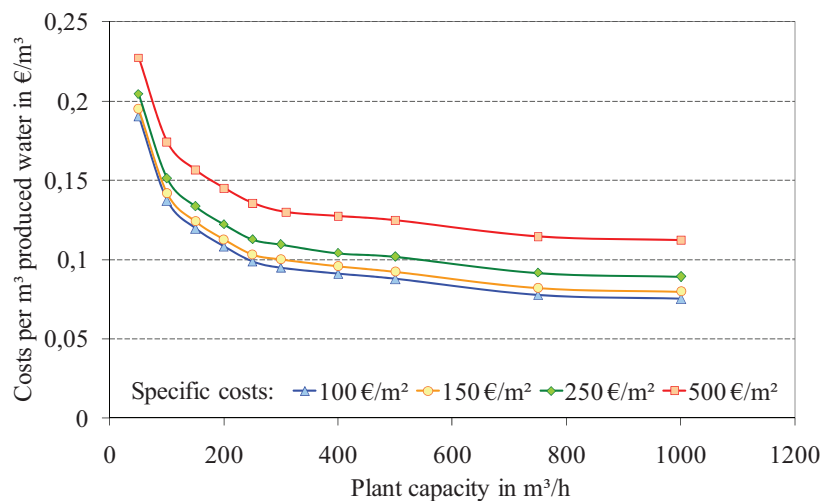

Figure 8.3: Treatment costs in dependence on the specific membrane costs (assumptions: membrane flux:  $143 \text{ L}/(\text{m}^2 \text{ h})$ , Mean/Max: 100%, interest loan: 5%, rate of price increase for ongoing costs: 0%)

In contrast to the specific membrane price, the operational filtration flux has a strong influence on the economic efficiency of the WTP as shown in Figure 8.4. Low membrane fluxes lead to significantly increased specific treatment costs, especially at fluxes of 100 L/(m<sup>2</sup> h) and below. The higher the membrane flux, the smaller the WTP that can be built. This reduces drastically the relatively high investment costs, for example for the process technology which contains significant amounts of stainless steel.

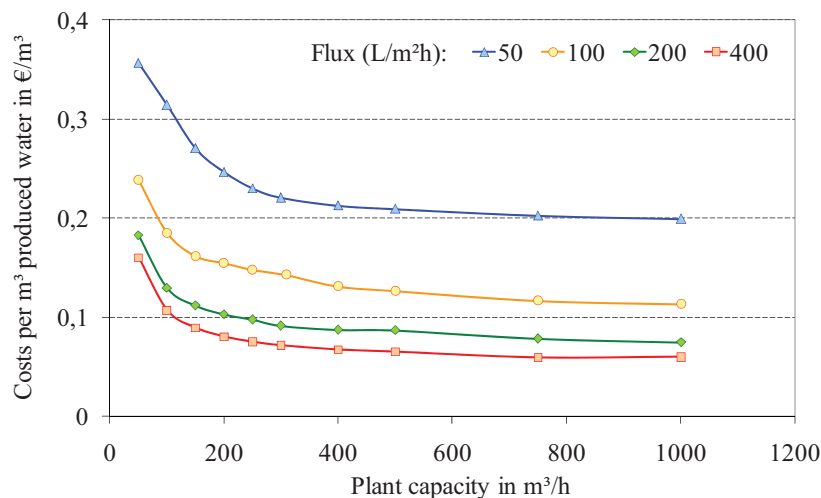

Figure 8.4: Treatment costs in dependence on the membrane flux (assumptions: Mean/Max: 100%, specific membrane costs: 250 €/m<sup>2</sup>, interest loan: 5%, rate of price increase for ongoing costs: 0%)

Furthermore, the influence of the mean compared to the maximum capacity utilisation of the WTP on the specific treatment costs was visualised (Figure 7.5). It is evident that there is an advantage if the WTP can be operated close to the maximum design capacity the majority of the time.

In summary, it can be said that ceramic membranes have an advantage if high membrane fluxes can be achieved and WTP capacity utilisation is high. These two parameters may be most important in order to decide whether the application of ceramic membranes is feasible or not. It becomes also clear that other operating conditions such as coagulant dosage or the amount of chemically enhanced backwashes only play a minor role and do not carry much weight compared to the investment costs for the membranes and the process technology. It was concluded that ceramic MF membranes, coupled with coagulation pre-treatment, may be a competitive treatment alternative, in spite of the higher investment for the ceramic membranes. However, it is also clear from the presented figures that small plants have a significant cost disadvantage compared to

larger plants. This may be of importance for the application in Norway, since the majority of the treatment plants are very small with capacities below 100 m<sup>3</sup>/h. However, such a behaviour is not unique to the investigated treatment scheme and is common for most treatment facilities.

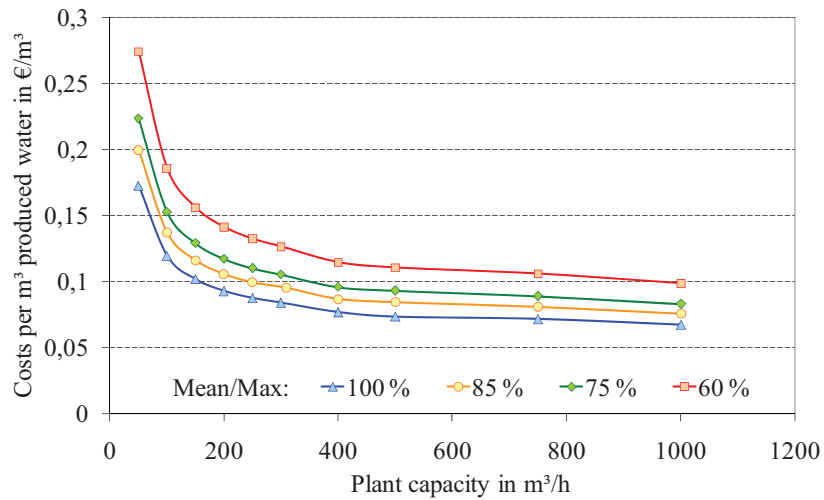

Figure 8.5: Treatment costs in dependence on the utilised plant capacity (assumptions: membrane flux: 250 L/(m<sup>2</sup> h), specific membrane costs: 250 €/m<sup>2</sup>, interest loan: 5%, rate of price increase for ongoing costs: 0%)

## Suggestions for future work

The following research topics have been identified as subjects for further research since they could not be included within the scope of this study or were only partially answered.

- A) **Long term experiments.** Most of the experiments carried out in this study had a duration of 48 hours. Some experiments were operated for up to 5 days, with the longest experiments being 2 weeks. Such operating times may be sufficient for comparison of different treatment conditions, but they allow only limited insight into process performance under more practically relevant conditions. Long term pilot studies should therefore be conducted to validate and test the recommended treatment schemes, designs and respective operating conditions in order to assess the sustainability and potential long term effects.
  
- B) **Treatment of real surface waters.** Even though this issue has been addressed, it was only done in short term experiments, where the water was transported into the laboratory. If real surface water is used compared to analogue water, such experimentation may result in first indications about the process performance. However, in order to fully evaluate the investigated treatment scheme, extensive tests with natural surface water are suggested. Such waters are subject to seasonal variations of the water quality (NOM characteristics and concentrations, shifts in temperature and turbidity) and furthermore, may have a lower alkalinity than the water used in the lab experiments. Therefore, the treatment results may differ from the findings in the lab, even though general tendencies are expected to be the same. The findings from this work should be verified in a field study.

- C) **Chemical enhanced backwashing (CEB).** All performed experiments were carried out without CEB procedures. Such operational backwashes will most likely improve the membrane performance by reducing the irreversible fouling, and a procedure regularly used in practise. In the short term experiments it was found that, depending on the operating conditions, low irreversible membrane fouling can be achieved. However, this may change during long term experiments and additional cleaning could become necessary.
- D) **Sludge treatment and minimisation.** Sludge production and treatment have not been included in this study. However, from a practical point of view this topic is important for the implementation of the treatment scheme investigated. Coagulation processes create characteristic sludge which needs to be managed and disposed of. Consequently, this aspect needs to be further investigated. Sludge production and overall solids and waste management (i.e. from backwashing procedures) are issues that must be resolved with respect to development of a sustainable drinking water treatment scheme.
- E) **Is low operation at low pH feasible?** As explained in Chapter 8.2, operation at low pH values may be an interesting alternative, since more NOM can be removed with less coagulant. However, additional post-treatment may be necessary and membrane fouling may increase. The charge of the membrane may change from negative to neutral or even positive. A neutral membrane surface may have advantages, since fouling charged water constituents may be reduced. A study of the treatment scheme investigated in this research work under such conditions may be beneficial in the development and implementation of an alternative treatment scheme well suited for conditions typically found in Nordic conditions.
- F) **Investigation of iron based coagulants.** In this work, mainly aluminium based coagulants were investigated. FeCl was also applied, but unfortunately under either challenging operating conditions or in experimental series where the membrane fouling was not monitored. Thus, either only incomplete experimental data or unfavourable data were collected. In spite of this, it is believed that FeCl or JKL may be practical alternatives, especially if coagulation at low pH-values is investigated. Further studies focusing on iron based coagulants are therefore suggested.
- G) **Investigation of floc breakage or long flocculation times on filtration performance.** This study has shown that low irreversible fouling rates can be achieved with inline coagulation at short flocculation times of 60 s. However, the reversible fouling was found to be significantly higher after inline coagulation with

flocculation times of up to 240 s, compared to tank coagulation pre-treatment with a total HRT of 20 min. It is assumed that this difference can be explained by either the significantly longer retention time in the tank coagulation pre-treatment, or by the fact that the breakage of the flocs in the membrane feeding pump actually has beneficial consequences for the filtration performance. However, the true reasons remain unclear at this stage and further research is necessary.

**H) Improved performance modelling and identification of parameter interactions.**

Applying PLS regression allowed for the statistical identification of influential operation parameters. However, it is also very obvious that a linear approach has only limited applications since many correlations seem to be of a non-linear nature. Furthermore, the consideration of parameter interactions may be crucial for improvement of the model quality. Such models may improve fitting of the experimental data, but they also contain more factors which need to be interpreted. Therefore, more research should be done to improve the prediction of process performance in dependent on operating conditions and raw water quality. For this, non-linear or neuronal techniques may be used. Ultimately, more mechanistic models should be developed.





# A

## Appendices

### A.1 Summary of DOC removal with PACl

The figures in this section summarise the DOC removal with PACl in dependence in the coagulant dosage and pH value, based on all experimental data.

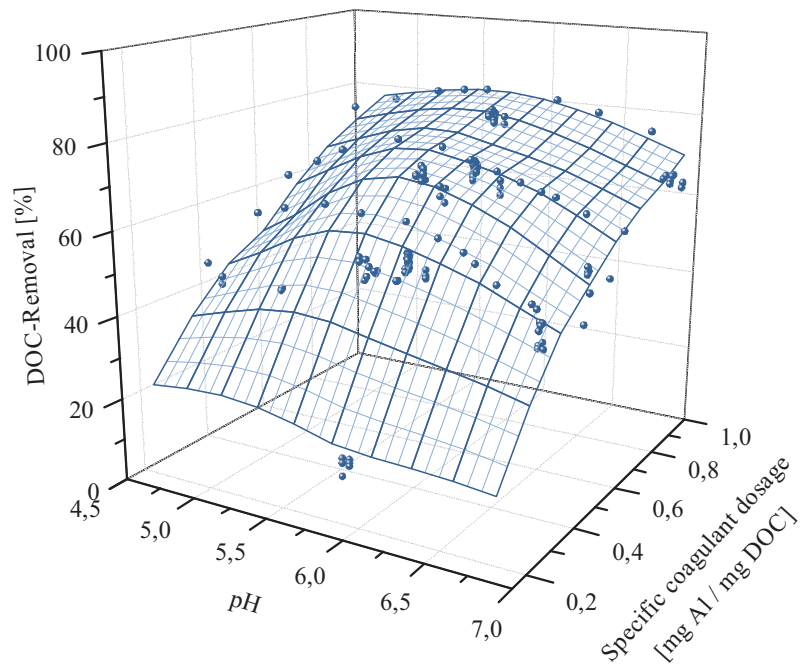

Figure A-1: DOC removal with PACl in dependence on pH and specific coagulant dosage (based on all experiments carried out with Norwegian NOM concentrate, n = 168)

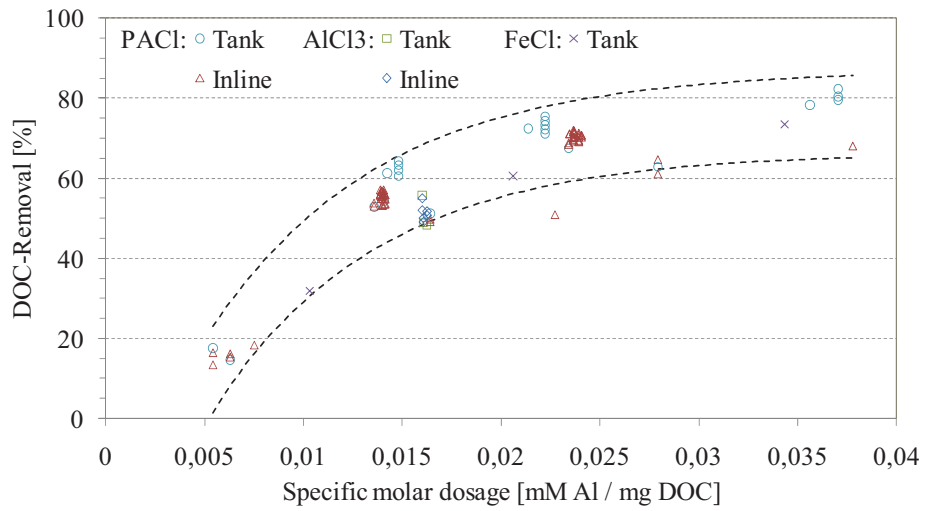

Figure A-2: DOC removal with PACl in dependence on the specific molar coagulant dosage at pH 6 (based on all experiments carried out with Norwegian NOM concentrate and a coagulation pH of 5.8 to 6.2, n = 100)

## A.2 Supplemental modelling data

### DOC removal - first regression

Included data sets: Publication 1-5, unpublished data

Predictor variables: Tank and inline pre-treatment configuration, Coagulants PACl, AlCl<sub>3</sub> and FeCl, flux, flocculation time and G-value, pH, specific molar coagulant dosage

Response variables: Percentage DOC removal

PLS components: 3

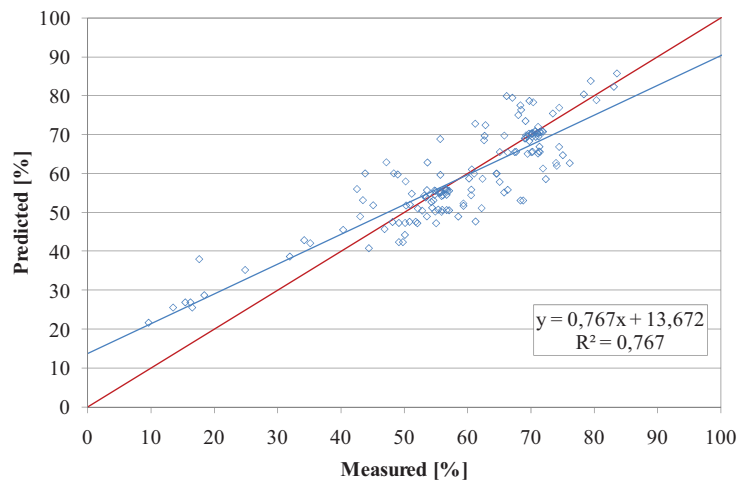

Figure A-3: Predicted versus measured plot for PLS modelling of DOC removal for regression results in Figure 7.6 (5 outliers, n = 155)

**DOC removal - second regression**

Included data sets: Publication 4, unpublished data

Predictor variables: Tank and inline pre-treatment configuration, flocculation time and G-value, specific molar coagulant dosage

Response variables: Percentage DOC removal

PLS components: 2

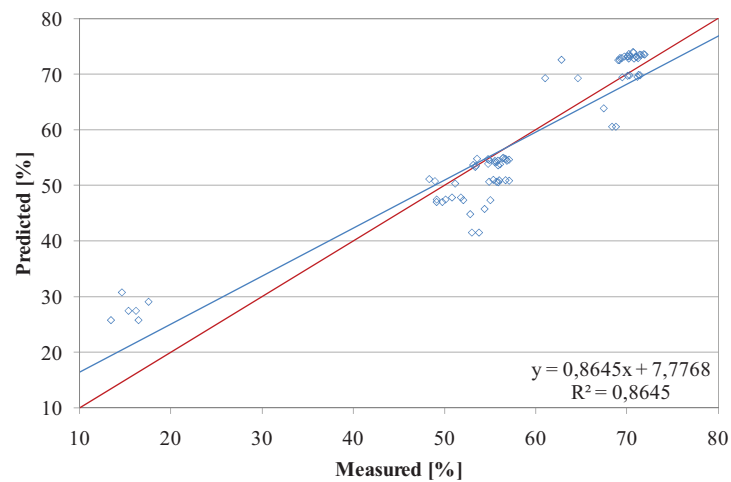

Figure A-4: Predicted versus measured plot for PLS modelling of DOC removal based in the experimental data from Publication 4 and unpublished data, comparing inline and tank coagulation, regression results are shown in Figure 7.7 (no outliers, n = 79)

**Residual metal**

Included data sets: Publication 1-4, unpublished data

Predictor variables: Tank and inline pre-treatment configuration, Coagulants PACl, AlCl<sub>3</sub> and FeCl, flux, flocculation time and G-value, pH, specific molar coagulant dosage

Response variables: Residual metal concentration

PLS components: 3

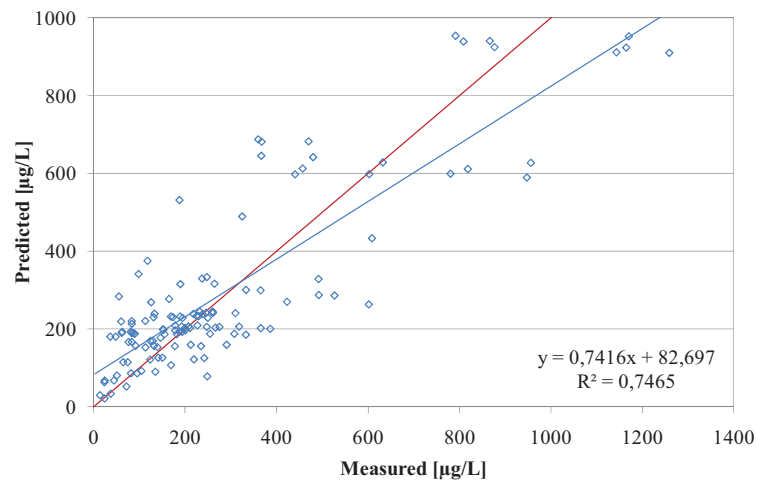

Figure A-5: Predicted versus measured plot for PLS modelling of residual metal concentration for regression results in Figure 7.9 (6 outliers removed,  $n = 136$ )

**Irreversible fouling**

Included data sets: Publication 1 and 4, unpublished data

Predictor variables: Tank and inline pre-treatment configuration, Coagulants PACl and AlCl<sub>3</sub>, flux, flocculation time and G-value, pH, specific molar coagulant dosage

Response variables: Irreversible membrane fouling

PLS components: 3

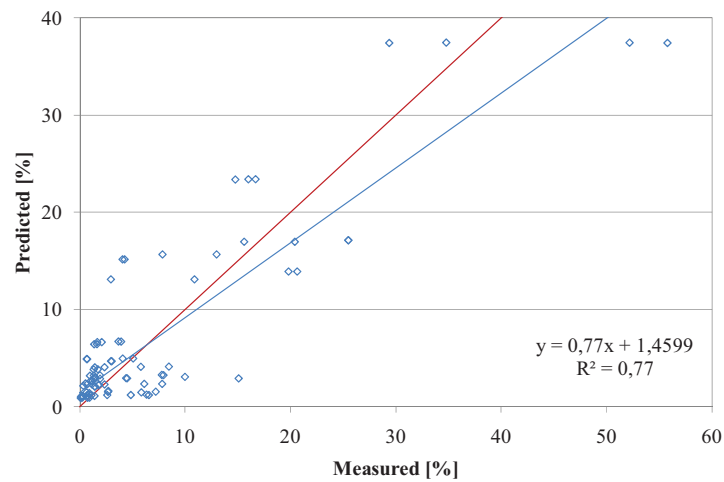

Figure A-6: Predicted versus measured plot for PLS modelling of irreversible fouling for regression results in Figure 7.12 (2 outliers removed, n =92)

**Reversible fouling - first regression**

Included data sets: Publication 1, 2 and 4, unpublished data

Predictor variables: Tank and inline pre-treatment configuration, Coagulants PACl, AlCl<sub>3</sub> and FeCl, flux, flocculation time and G-value, pH, specific molar coagulant dosage

Response variables: Reversible membrane fouling

PLS components: 3

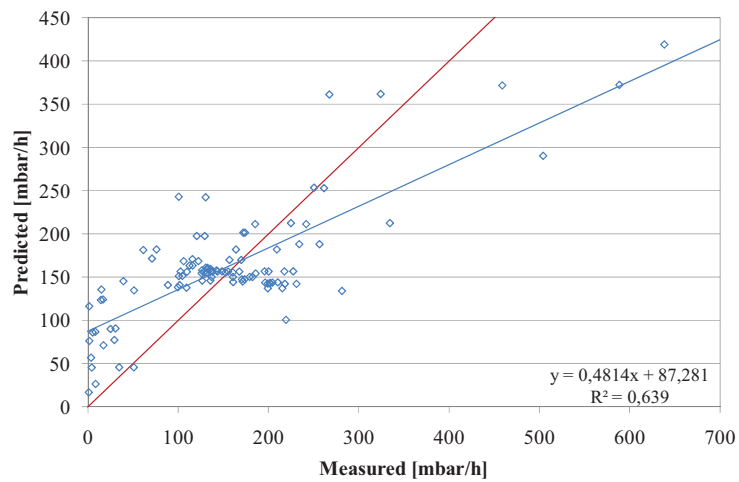

Figure A-7: Predicted versus measured plot for PLS modelling of reversible fouling for regression results in Figure 7.18 (6 outliers removed, n =112)

**Reversible fouling - second regression**

Included data sets: Publication 1 and 4, unpublished data

Predictor variables: Tank and inline pre-treatment configuration, Coagulants PACl and  $AlCl_3$ , flux, flocculation time and G-value, pH, specific molar coagulant dosage

Response variables: Reversible membrane fouling

PLS components: 2

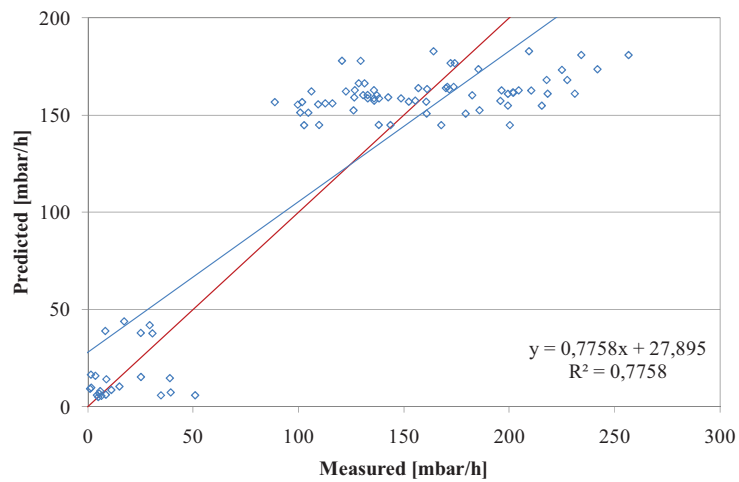

Figure A-8: Predicted versus measured plot for PLS modelling of reversible fouling for regression results in Figure 7.20 (3 outliers removed, n = 91)



Data summary

Table A-1: Summary of the data sets used for PLS regression

| Data set      | No. | Predictor variables |      |            |     |                   |                      |                   |                    | Response variables |                       |                     |                      |                |                      |                            |                             |
|---------------|-----|---------------------|------|------------|-----|-------------------|----------------------|-------------------|--------------------|--------------------|-----------------------|---------------------|----------------------|----------------|----------------------|----------------------------|-----------------------------|
|               |     | Pre-treatment       |      | Coagulants |     |                   | Flux                 | Flocculation time | Flocculation G     | pH                 | Specific molar dosage | DOC removal (first) | DOC removal (second) | Residual Metal | Irreversible fouling | Reversible fouling (first) | Reversible fouling (second) |
|               |     | Inline              | Tank | FeCl       | PAC | AlCl <sub>3</sub> | L/(m <sup>2</sup> h) | [s]               | [s <sup>-1</sup> ] | [ ]                | [mM Me/mg DOC]        | [%]                 | [%]                  | [µg/L]         | [mbar/h]             | [mbar/h]                   | [mbar/h]                    |
| Publication 1 | 01  | 0                   | 1    | 0          | 1   | 0                 | 143                  | 1260              | 12                 | 4,5                | 0,0142                | 50,20               | n.i.                 | no data        | no data              | no data                    | no data                     |
|               | 02  | 0                   | 1    | 0          | 1   | 0                 | 143                  | 1260              | 12                 | 4,5                | 0,0214                | 55,68               | n.i.                 | no data        | no data              | no data                    | no data                     |
|               | 03  | 0                   | 1    | 0          | 1   | 0                 | 143                  | 1260              | 12                 | 4,5                | 0,0356                | 72,68               | n.i.                 | no data        | no data              | no data                    | no data                     |
|               | 04  | 0                   | 1    | 0          | 1   | 0                 | 143                  | 1260              | 12                 | 5                  | 0,0142                | 56,67656            | n.i.                 | 1555           | 0,6                  | 5                          | 5                           |
|               | 05  | 0                   | 1    | 0          | 1   | 0                 | 143                  | 1260              | 12                 | 5                  | 0,0214                | 66,34               | n.i.                 | 2722           | 0,2                  | 6                          | 6                           |
|               | 06  | 0                   | 1    | 0          | 1   | 0                 | 143                  | 1260              | 12                 | 5                  | 0,0356                | 76,84               | n.i.                 | 4013           | 0,3                  | 9                          | 9                           |
|               | 07  | 0                   | 1    | 0          | 1   | 0                 | 143                  | 1260              | 12                 | 5,5                | 0,0142                | 62,22               | n.i.                 | 601            | 0,8                  | 6                          | 6                           |
|               | 08  | 0                   | 1    | 0          | 1   | 0                 | 143                  | 1260              | 12                 | 5,5                | 0,0214                | 74,10               | n.i.                 | 1246           | 0,3                  | 11                         | 11                          |
|               | 09  | 0                   | 1    | 0          | 1   | 0                 | 143                  | 1260              | 12                 | 5,5                | 0,0356                | 79,47               | n.i.                 | 3114           | 1,7                  | 39                         | 39                          |
|               | 10  | 0                   | 1    | 0          | 1   | 0                 | 143                  | 1260              | 12                 | 6                  | 0,0142                | 61,26               | n.i.                 | 169            | 1,8                  | 9                          | 9                           |
|               | 11  | 0                   | 1    | 0          | 1   | 0                 | 143                  | 1260              | 12                 | 6                  | 0,0214                | 72,37               | n.i.                 | 248            | 0,1                  | 1                          | 1                           |
|               | 12  | 0                   | 1    | 0          | 1   | 0                 | 143                  | 1260              | 12                 | 6                  | 0,0356                | 78,38               | n.i.                 | 729            | 0,3                  | 25                         | 25                          |
|               | 13  | 0                   | 1    | 0          | 1   | 0                 | 143                  | 1260              | 12                 | 6,5                | 0,0142                | 50,09               | n.i.                 | 77             | 1,8                  | 5                          | 5                           |
|               | 14  | 0                   | 1    | 0          | 1   | 0                 | 143                  | 1260              | 12                 | 6,5                | 0,0214                | 65,78               | n.i.                 | 52             | 0,3                  | 2                          | 2                           |
|               | 15  | 0                   | 1    | 0          | 1   | 0                 | 143                  | 1260              | 12                 | 6,5                | 0,0356                | 74,48               | n.i.                 | 12             | 0,2                  | 4                          | 4                           |
|               | 16  | 0                   | 1    | 0          | 1   | 0                 | 143                  | 1260              | 12                 | 7                  | 0,0142                | 44,39               | n.i.                 | 47             | 0,4                  | 39                         | 39                          |
|               | 17  | 0                   | 1    | 0          | 1   | 0                 | 143                  | 1260              | 12                 | 7                  | 0,0214                | 59,35               | n.i.                 | 32             | 0,1                  | 15                         | 15                          |
|               | 18  | 0                   | 1    | 0          | 1   | 0                 | 143                  | 1260              | 12                 | 7                  | 0,0356                | 69,16               | n.i.                 | 22             | 0,1                  | 1                          | 1                           |
|               | 19  | 0                   | 1    | 1          | 0   | 0                 | 143                  | 1260              | 12                 | 4,5                | 0,0103                | 43,01               | n.i.                 | no data        | no data              | no data                    | no data                     |
|               | 20  | 0                   | 1    | 1          | 0   | 0                 | 143                  | 1260              | 12                 | 4,5                | 0,0206                | 75,06               | n.i.                 | no data        | no data              | no data                    | no data                     |
|               | 21  | 0                   | 1    | 1          | 0   | 0                 | 143                  | 1260              | 12                 | 4,5                | 0,0343                | 83,62               | n.i.                 | no data        | no data              | no data                    | no data                     |
|               | 22  | 0                   | 1    | 1          | 0   | 0                 | 143                  | 1260              | 12                 | 5                  | 0,0103                | 40,32               | n.i.                 | 359            | no data              | no data                    | no data                     |
|               | 23  | 0                   | 1    | 1          | 0   | 0                 | 143                  | 1260              | 12                 | 5                  | 0,0206                | 71,92               | n.i.                 | 366            | no data              | no data                    | no data                     |
|               | 24  | 0                   | 1    | 1          | 0   | 0                 | 143                  | 1260              | 12                 | 5                  | 0,0343                | 83,13               | n.i.                 | 947            | no data              | no data                    | no data                     |
|               | 25  | 0                   | 1    | 1          | 0   | 0                 | 143                  | 1260              | 12                 | 5,5                | 0,0103                | 35,12               | n.i.                 | 187            | no data              | no data                    | no data                     |
|               | 26  | 0                   | 1    | 1          | 0   | 0                 | 143                  | 1260              | 12                 | 5,5                | 0,0206                | 65,07               | n.i.                 | 325            | no data              | no data                    | no data                     |
|               | 27  | 0                   | 1    | 1          | 0   | 0                 | 143                  | 1260              | 12                 | 5,5                | 0,0343                | 80,37               | n.i.                 | 608            | no data              | no data                    | no data                     |
|               | 28  | 0                   | 1    | 1          | 0   | 0                 | 143                  | 1260              | 12                 | 6                  | 0,0103                | 31,90               | n.i.                 | 118            | no data              | no data                    | no data                     |
|               | 29  | 0                   | 1    | 1          | 0   | 0                 | 143                  | 1260              | 12                 | 6                  | 0,0206                | 60,56               | n.i.                 | 247            | no data              | no data                    | no data                     |
|               | 30  | 0                   | 1    | 1          | 0   | 0                 | 143                  | 1260              | 12                 | 6                  | 0,0343                | 73,48               | n.i.                 | 165            | no data              | no data                    | no data                     |
|               | 31  | 0                   | 1    | 1          | 0   | 0                 | 143                  | 1260              | 12                 | 6,5                | 0,0103                | 24,83               | n.i.                 | 60             | no data              | no data                    | no data                     |
|               | 32  | 0                   | 1    | 1          | 0   | 0                 | 143                  | 1260              | 12                 | 6,5                | 0,0206                | 52,13               | n.i.                 | 146            | no data              | no data                    | no data                     |
|               | 33  | 0                   | 1    | 1          | 0   | 0                 | 143                  | 1260              | 12                 | 6,5                | 0,0343                | 71,14               | n.i.                 | 123            | no data              | no data                    | no data                     |
|               | 34  | 0                   | 1    | 1          | 0   | 0                 | 143                  | 1260              | 12                 | 7                  | 0,0103                | 9,13                | n.i.                 | 23             | no data              | no data                    | no data                     |
|               | 35  | 0                   | 1    | 1          | 0   | 0                 | 143                  | 1260              | 12                 | 7                  | 0,0206                | 48,13               | n.i.                 | 24             | no data              | no data                    | no data                     |
|               | 36  | 0                   | 1    | 1          | 0   | 0                 | 143                  | 1260              | 12                 | 7                  | 0,0343                | 62,60               | n.i.                 | 151            | no data              | no data                    | no data                     |
| Publication 2 | 01  | 1                   | 0    | 1          | 0   | 0                 | 143                  | 8                 | 60                 | 4,5                | 0,0195                | 71,37               | n.i.                 | 791            | n.i.                 | 17                         | n.i.                        |
|               | 02  | 1                   | 0    | 1          | 0   | 0                 | 143                  | 8                 | 60                 | 5,5                | 0,0195                | 43,80               | n.i.                 | 480            | n.i.                 | 101                        | n.i.                        |
|               | 03  | 1                   | 0    | 1          | 0   | 0                 | 143                  | 8                 | 60                 | 6,5                | 0,0195                | 43,45               | n.i.                 | 237            | n.i.                 | 324                        | n.i.                        |
|               | 04  | 1                   | 0    | 1          | 0   | 0                 | 143                  | 8                 | 300                | 4,5                | 0,0195                | 73,98               | n.i.                 | 876            | n.i.                 | 51                         | n.i.                        |
|               | 05  | 1                   | 0    | 1          | 0   | 0                 | 143                  | 8                 | 300                | 5,5                | 0,0195                | 60,59               | n.i.                 | 457            | n.i.                 | 251                        | n.i.                        |
|               | 06  | 1                   | 0    | 1          | 0   | 0                 | 143                  | 8                 | 300                | 6,5                | 0,0195                | 53,56               | n.i.                 | 333            | n.i.                 | 589                        | n.i.                        |
|               | 07  | 1                   | 0    | 1          | 0   | 0                 | 143                  | 30                | 60                 | 4,5                | 0,0195                | 74,47               | n.i.                 | 1170           | n.i.                 | 14                         | n.i.                        |
|               | 08  | 1                   | 0    | 1          | 0   | 0                 | 143                  | 30                | 60                 | 5,5                | 0,0195                | 64,54               | n.i.                 | 1198           | n.i.                 | 130                        | n.i.                        |
|               | 09  | 1                   | 0    | 1          | 0   | 0                 | 143                  | 30                | 60                 | 6,5                | 0,0195                | 54,61               | n.i.                 | 491            | n.i.                 | 268                        | n.i.                        |
|               | 10  | 1                   | 0    | 1          | 0   | 0                 | 143                  | 30                | 300                | 4,5                | 0,0195                | 76,15               | n.i.                 | 1164           | n.i.                 | 282                        | n.i.                        |
|               | 11  | 1                   | 0    | 1          | 0   | 0                 | 143                  | 30                | 300                | 5,5                | 0,0195                | 66,35               | n.i.                 | 818            | n.i.                 | 262                        | n.i.                        |
|               | 12  | 1                   | 0    | 1          | 0   | 0                 | 143                  | 30                | 300                | 6,5                | 0,0195                | 58,52               | n.i.                 | 365            | n.i.                 | 459                        | n.i.                        |
|               | 13  | 1                   | 0    | 1          | 0   | 0                 | 223                  | 8                 | 60                 | 4,5                | 0,0195                | 65,81               | n.i.                 | 866            | n.i.                 | 71                         | n.i.                        |
|               | 14  | 1                   | 0    | 1          | 0   | 0                 | 223                  | 8                 | 60                 | 5,5                | 0,0195                | 47,16               | n.i.                 | 632            | n.i.                 | 504                        | n.i.                        |
|               | 15  | 1                   | 0    | 1          | 0   | 0                 | 223                  | 8                 | 60                 | 6,5                | 0,0195                | 42,51               | n.i.                 | 264            | n.i.                 | 1487                       | n.i.                        |
|               | 16  | 1                   | 0    | 1          | 0   | 0                 | 223                  | 8                 | 300                | 4,5                | 0,0195                | 67,67               | n.i.                 | 1143           | n.i.                 | 76                         | n.i.                        |
|               | 17  | 1                   | 0    | 1          | 0   | 0                 | 223                  | 8                 | 300                | 5,5                | 0,0195                | 60,23               | n.i.                 | 780            | n.i.                 | 970                        | n.i.                        |
|               | 18  | 1                   | 0    | 1          | 0   | 0                 | 223                  | 8                 | 300                | 6,5                | 0,0195                | 45,07               | n.i.                 | 492            | n.i.                 | 707                        | n.i.                        |
|               | 19  | 1                   | 0    | 1          | 0   | 0                 | 223                  | 30                | 60                 | 4,5                | 0,0195                | 62,69               | n.i.                 | 808            | n.i.                 | 116                        | n.i.                        |
|               | 20  | 1                   | 0    | 1          | 0   | 0                 | 223                  | 30                | 60                 | 5,5                | 0,0195                | 53,65               | n.i.                 | 955            | n.i.                 | 855                        | n.i.                        |
|               | 21  | 1                   | 0    | 1          | 0   | 0                 | 223                  | 30                | 60                 | 6,5                | 0,0195                | 33,50               | n.i.                 | 189            | n.i.                 | 762                        | n.i.                        |
|               | 22  | 1                   | 0    | 1          | 0   | 0                 | 223                  | 30                | 300                | 4,5                | 0,0195                | 65,09               | n.i.                 | 1258           | n.i.                 | 61                         | n.i.                        |
|               | 23  | 1                   | 0    | 1          | 0   | 0                 | 223                  | 30                | 300                | 5,5                | 0,0195                | 62,36               | n.i.                 | 602            | n.i.                 | 1149                       | n.i.                        |
|               | 24  | 1                   | 0    | 1          | 0   | 0                 | 223                  | 30                | 300                | 6,5                | 0,0195                | 50,28               | n.i.                 | 526            | n.i.                 | 639                        | n.i.                        |

Legend: n.i. marks values that are not included, orange fields represent outliers

Table A-1 (continued)

| Data set      | No. | Predictor variables |      |            |      |                   |                      |                   |                    | Response variables |                       |                     |                      |                |                      |                            |                             |
|---------------|-----|---------------------|------|------------|------|-------------------|----------------------|-------------------|--------------------|--------------------|-----------------------|---------------------|----------------------|----------------|----------------------|----------------------------|-----------------------------|
|               |     | Pre-treatment       |      | Coagulants |      |                   | Flux                 | Flocculation time | Flocculation G     | pH                 | Specific molar dosage | DOC removal (first) | DOC removal (second) | Residual Metal | Irreversible fouling | Reversible fouling (first) | Reversible fouling (second) |
|               |     | Inline              | Tank | FeCl       | PACl | AlCl <sub>3</sub> | L/(m <sup>2</sup> h) | [s]               | [s <sup>-1</sup> ] | [ ]                | [mM Me/mg DOC]        | [%]                 | [%]                  | [µg/L]         | [mbar/h]             | [mbar/h]                   | [mbar/h]                    |
| Publication 3 | 01  | 1                   | 0    | 0          | 1    | 0                 | 143                  | 40                | 500                | 5,5                | 0,0178                | 54,27               | n.i.                 | 98             | no data              | no data                    | no data                     |
|               | 02  | 1                   | 0    | 0          | 1    | 0                 | 143                  | 40                | 500                | 5,5                | 0,0353                | 67,08               | n.i.                 | 422            | no data              | no data                    | no data                     |
|               | 03  | 1                   | 0    | 0          | 1    | 0                 | 143                  | 40                | 500                | 5,5                | 0,0356                | 66,17               | n.i.                 | 126            | no data              | no data                    | no data                     |
|               | 04  | 1                   | 0    | 0          | 1    | 0                 | 143                  | 40                | 500                | 6,5                | 0,0177                | 46,87               | n.i.                 | 14             | no data              | no data                    | no data                     |
|               | 05  | 1                   | 0    | 0          | 1    | 0                 | 143                  | 40                | 500                | 6,5                | 0,0354                | 61,21               | n.i.                 | 20             | no data              | no data                    | no data                     |
|               | 06  | 1                   | 0    | 1          | 0    | 0                 | 143                  | 40                | 500                | 5                  | 0,0172                | 59,34               | n.i.                 | 281            | no data              | no data                    | no data                     |
|               | 07  | 1                   | 0    | 1          | 0    | 0                 | 143                  | 40                | 500                | 5                  | 0,0342                | 70,37               | n.i.                 | 470            | no data              | no data                    | no data                     |
|               | 08  | 1                   | 0    | 1          | 0    | 0                 | 143                  | 40                | 500                | 5                  | 0,0345                | 69,77               | n.i.                 | 367            | no data              | no data                    | no data                     |
|               | 09  | 1                   | 0    | 1          | 0    | 0                 | 143                  | 40                | 500                | 6,5                | 0,0172                | 59,34               | n.i.                 | 55             | no data              | no data                    | no data                     |
|               | 10  | 1                   | 0    | 1          | 0    | 0                 | 143                  | 40                | 500                | 6,5                | 0,0345                | 69,77               | n.i.                 | 83             | no data              | no data                    | no data                     |
|               | 11  | 0                   | 1    | 0          | 1    | 0                 | 143                  | 40                | 500                | 5,5                | 0,0353                | 68,35               | n.i.                 | 333            | no data              | no data                    | no data                     |
|               | 12  | 0                   | 1    | 1          | 0    | 0                 | 143                  | 40                | 500                | 5                  | 0,0342                | 68,46               | n.i.                 | 440            | no data              | no data                    | no data                     |
| Publication 4 | 01  | 1                   | 0    | 0          | 1    | 0                 | 250                  | 10                | 4                  | 6                  | 0,0140                | 56,63               | 56,63                | 260            | 4,4                  | 138                        | 138                         |
|               | 02  | 1                   | 0    | 0          | 1    | 0                 | 250                  | 10                | 4                  | 6                  | 0,0141                | 56,47               | 56,47                | 232            | 4,5                  | 149                        | 149                         |
|               | 03  | 1                   | 0    | 0          | 1    | 0                 | 250                  | 10                | 4                  | 6                  | 0,0235                | 71,00               | 71,00                | 318            | 6,4                  | 210                        | 210                         |
|               | 04  | 1                   | 0    | 0          | 1    | 0                 | 250                  | 10                | 4                  | 6                  | 0,0237                | 71,94               | 71,94                | 247            | 4,9                  | 196                        | 196                         |
|               | 05  | 1                   | 0    | 0          | 1    | 0                 | 250                  | 10                | 4                  | 6                  | 0,0237                | 71,83               | 71,83                | 275            | 6,6                  | 204                        | 204                         |
|               | 06  | 1                   | 0    | 0          | 1    | 0                 | 250                  | 10                | 31                 | 6                  | 0,0140                | 54,92               | 54,92                | 261            | 7,8                  | 126                        | 126                         |
|               | 07  | 1                   | 0    | 0          | 1    | 0                 | 250                  | 10                | 31                 | 6                  | 0,0141                | 53,57               | 53,57                | 310            | 8,0                  | 143                        | 143                         |
|               | 08  | 1                   | 0    | 0          | 1    | 0                 | 250                  | 10                | 31                 | 6                  | 0,0237                | 70,34               | 70,34                | 365            | 7,2                  | 172                        | 172                         |
|               | 09  | 1                   | 0    | 0          | 1    | 0                 | 250                  | 10                | 31                 | 6                  | 0,0241                | 70,66               | 70,66                | 386            | 5,9                  | 161                        | 161                         |
|               | 10  | 1                   | 0    | 0          | 1    | 0                 | 250                  | 10                | 98                 | 6                  | 0,0140                | 53,14               | 53,14                | 225            | 8,5                  | 131                        | 131                         |
|               | 11  | 1                   | 0    | 0          | 1    | 0                 | 250                  | 10                | 98                 | 6                  | 0,0141                | 54,78               | 54,78                | 230            | 5,8                  | 133                        | 133                         |
|               | 12  | 1                   | 0    | 0          | 1    | 0                 | 250                  | 10                | 98                 | 6                  | 0,0239                | 71,22               | 71,22                | 193            | 7,8                  | 174                        | 174                         |
|               | 13  | 1                   | 0    | 0          | 1    | 0                 | 250                  | 10                | 98                 | 6                  | 0,0239                | 69,43               | 69,43                | 187            | 6,1                  | 171                        | 171                         |
|               | 14  | 1                   | 0    | 0          | 1    | 0                 | 250                  | 10                | 300                | 6                  | 0,0139                | 55,99               | 55,99                | 227            | 3,7                  | 157                        | 157                         |
|               | 15  | 1                   | 0    | 0          | 1    | 0                 | 250                  | 10                | 300                | 6                  | 0,0139                | 55,36               | 55,36                | 178            | 4,0                  | 170                        | 170                         |
|               | 16  | 1                   | 0    | 0          | 1    | 0                 | 250                  | 10                | 300                | 6                  | 0,0236                | 70,28               | 70,28                | 129            | 5,1                  | 228                        | 228                         |
|               | 17  | 1                   | 0    | 0          | 1    | 0                 | 250                  | 10                | 300                | 6                  | 0,0237                | 71,28               | 71,28                | 124            | 4,1                  | 218                        | 218                         |
|               | 18  | 1                   | 0    | 0          | 1    | 0                 | 250                  | 60                | 4                  | 6                  | 0,0140                | 56,74               | 56,74                | 259            | 2,0                  | 161                        | 161                         |
|               | 19  | 1                   | 0    | 0          | 1    | 0                 | 250                  | 60                | 4                  | 6                  | 0,0141                | 56,38               | 56,38                | 246            | 1,4                  | 152                        | 152                         |
|               | 20  | 1                   | 0    | 0          | 1    | 0                 | 250                  | 60                | 4                  | 6                  | 0,0235                | 71,07               | 71,07                | 266            | 1,1                  | 199                        | 199                         |
|               | 21  | 1                   | 0    | 0          | 1    | 0                 | 250                  | 60                | 4                  | 6                  | 0,0237                | 71,54               | 71,54                | 211            | 0,7                  | 218                        | 218                         |
|               | 22  | 1                   | 0    | 0          | 1    | 0                 | 250                  | 60                | 4                  | 6                  | 0,0237                | 71,40               | 71,40                | 199            | 0,8                  | 231                        | 231                         |
|               | 23  | 1                   | 0    | 0          | 1    | 0                 | 250                  | 60                | 31                 | 6                  | 0,0140                | 55,52               | 55,52                | 218            | 1,4                  | 136                        | 136                         |
|               | 24  | 1                   | 0    | 0          | 1    | 0                 | 250                  | 60                | 31                 | 6                  | 0,0141                | 54,77               | 54,77                | 238            | 1,0                  | 155                        | 155                         |
|               | 25  | 1                   | 0    | 0          | 1    | 0                 | 250                  | 60                | 31                 | 6                  | 0,0237                | 70,11               | 70,11                | 152            | 0,7                  | 202                        | 202                         |
|               | 26  | 1                   | 0    | 0          | 1    | 0                 | 250                  | 60                | 31                 | 6                  | 0,0241                | 70,72               | 70,72                | 152            | 0,9                  | 202                        | 202                         |
|               | 27  | 1                   | 0    | 0          | 1    | 0                 | 250                  | 60                | 98                 | 6                  | 0,0140                | 55,88               | 55,88                | 173            | 2,4                  | 136                        | 136                         |
|               | 28  | 1                   | 0    | 0          | 1    | 0                 | 250                  | 60                | 98                 | 6                  | 0,0141                | 56,09               | 56,09                | 131            | 1,5                  | 133                        | 133                         |
|               | 29  | 1                   | 0    | 0          | 1    | 0                 | 250                  | 60                | 98                 | 6                  | 0,0239                | 70,78               | 70,78                | 61             | 1,2                  | 136                        | 136                         |
|               | 30  | 1                   | 0    | 0          | 1    | 0                 | 250                  | 60                | 98                 | 6                  | 0,0239                | 70,20               | 70,20                | 83             | 2,4                  | 127                        | 127                         |
|               | 31  | 1                   | 0    | 0          | 1    | 0                 | 250                  | 60                | 300                | 6                  | 0,0139                | 57,08               | 57,08                | 207            | 1,7                  | 122                        | 122                         |
|               | 32  | 1                   | 0    | 0          | 1    | 0                 | 250                  | 60                | 300                | 6                  | 0,0139                | 56,69               | 56,69                | 192            | 2,1                  | 106                        | 106                         |
|               | 33  | 1                   | 0    | 0          | 1    | 0                 | 250                  | 60                | 300                | 6                  | 0,0236                | 70,08               | 70,08                | 83             | 0,7                  | 131                        | 131                         |
|               | 34  | 1                   | 0    | 0          | 1    | 0                 | 250                  | 60                | 300                | 6                  | 0,0237                | 71,44               | 71,44                | 76             | 0,7                  | 129                        | 129                         |
|               | 35  | 1                   | 0    | 0          | 1    | 0                 | 250                  | 240               | 4                  | 6                  | 0,0140                | 56,84               | 56,84                | 189            | 1,2                  | 179                        | 179                         |
|               | 36  | 1                   | 0    | 0          | 1    | 0                 | 250                  | 240               | 4                  | 6                  | 0,0141                | 57,08               | 57,08                | 169            | 1,1                  | 161                        | 161                         |
|               | 37  | 1                   | 0    | 0          | 1    | 0                 | 250                  | 240               | 4                  | 6                  | 0,0237                | 69,71               | 69,71                | 81             | 1,0                  | 215                        | 215                         |
|               | 38  | 1                   | 0    | 0          | 1    | 0                 | 250                  | 240               | 4                  | 6                  | 0,0237                | 70,08               | 70,08                | 62             | 0,8                  | 199                        | 199                         |
| 39            | 1   | 0                   | 0    | 1          | 0    | 250               | 240                  | 31                | 6                  | 0,0140             | 55,51                 | 55,51               | 249                  | 1,4            | 105                  | 105                        |                             |
| 40            | 1   | 0                   | 0    | 1          | 0    | 250               | 240                  | 31                | 6                  | 0,0141             | 55,85                 | 55,85               | 194                  | 1,5            | 101                  | 101                        |                             |
| 41            | 1   | 0                   | 0    | 1          | 0    | 250               | 240                  | 31                | 6                  | 0,0237             | 69,23                 | 69,23               | 86                   | 0,9            | 100                  | 100                        |                             |
| 42            | 1   | 0                   | 0    | 1          | 0    | 250               | 240                  | 31                | 6                  | 0,0241             | 70,21                 | 70,21               | 90                   | 2,6            | 109                  | 109                        |                             |
| 43            | 1   | 0                   | 0    | 1          | 0    | 250               | 240                  | 98                | 6                  | 0,0140             | 53,38                 | 53,38               | 113                  | 1,7            | 126                  | 126                        |                             |
| 44            | 1   | 0                   | 0    | 1          | 0    | 250               | 240                  | 98                | 6                  | 0,0141             | 53,47                 | 53,47               | 83                   | 1,4            | 186                  | 186                        |                             |
| 45            | 1   | 0                   | 0    | 1          | 0    | 250               | 240                  | 98                | 6                  | 0,0239             | 69,18                 | 69,18               | 36                   | 1,5            | 102                  | 102                        |                             |
| 46            | 1   | 0                   | 0    | 1          | 0    | 250               | 240                  | 98                | 6                  | 0,0239             | 69,04                 | 69,04               | 48                   | 1,4            | 89                   | 89                         |                             |
| 47            | 1   | 0                   | 0    | 1          | 0    | 250               | 240                  | 300               | 6                  | 0,0139             | 55,90                 | 55,90               | 200                  | 1,7            | 116                  | 116                        |                             |
| 48            | 1   | 0                   | 0    | 1          | 0    | 250               | 240                  | 300               | 6                  | 0,0139             | 54,89                 | 54,89               | 178                  | 1,4            | 113                  | 113                        |                             |
| 49            | 1   | 0                   | 0    | 1          | 0    | 250               | 240                  | 300               | 6                  | 0,0236             | 69,49                 | 69,49               | 91                   | 3,0            | 182                  | 182                        |                             |
| 50            | 1   | 0                   | 0    | 1          | 0    | 250               | 240                  | 300               | 6                  | 0,0237             | 71,14                 | 71,14               | 132                  | 3,1            | 137                  | 137                        |                             |

Legend: n.i. marks values that are not included, orange fields represent outliers

Table A-1 (continued)

| Data set         | No. | Predictor variables |      |            |      |       |                      |                   |                    | Response variables |                       |                     |                      |                |                      |                            |                             |
|------------------|-----|---------------------|------|------------|------|-------|----------------------|-------------------|--------------------|--------------------|-----------------------|---------------------|----------------------|----------------|----------------------|----------------------------|-----------------------------|
|                  |     | Pre-treatment       |      | Coagulants |      |       | Flux                 | Flocculation time | Flocculation G     | pH                 | Specific molar dosage | DOC removal (first) | DOC removal (second) | Residual Metal | Irreversible fouling | Reversible fouling (first) | Reversible fouling (second) |
|                  |     | Inline              | Tank | FeCl       | PACl | AlCl3 | L/(m <sup>2</sup> h) | [s]               | [s <sup>-1</sup> ] | []                 | [mM Me/mg DOC]        | [%]                 | [%]                  | [µg/L]         | [mbar/h]             | [mbar/h]                   | [mbar/h]                    |
| Publication 5    | 01  | 1                   | 0    | 0          | 1    | 0     | 250                  | 15                | 1000               | 5                  | 0,0079                | 12,66               | n.i.                 | n.i.           | n.i.                 | n.i.                       | n.i.                        |
|                  | 02  | 1                   | 0    | 0          | 1    | 0     | 250                  | 15                | 1000               | 5                  | 0,0242                | 60,66               | n.i.                 | n.i.           | n.i.                 | n.i.                       | n.i.                        |
|                  | 03  | 1                   | 0    | 0          | 1    | 0     | 250                  | 15                | 1000               | 5                  | 0,0405                | 72,88               | n.i.                 | n.i.           | n.i.                 | n.i.                       | n.i.                        |
|                  | 04  | 1                   | 0    | 0          | 1    | 0     | 250                  | 15                | 1000               | 6                  | 0,0075                | 18,36               | n.i.                 | n.i.           | n.i.                 | n.i.                       | n.i.                        |
|                  | 05  | 1                   | 0    | 0          | 1    | 0     | 250                  | 15                | 1000               | 6                  | 0,0227                | 50,88               | n.i.                 | n.i.           | n.i.                 | n.i.                       | n.i.                        |
|                  | 06  | 1                   | 0    | 0          | 1    | 0     | 250                  | 15                | 1000               | 6                  | 0,0378                | 68,01               | n.i.                 | n.i.           | n.i.                 | n.i.                       | n.i.                        |
|                  | 07  | 1                   | 0    | 0          | 1    | 0     | 250                  | 15                | 1000               | 7                  | 0,0074                | 9,56                | n.i.                 | n.i.           | n.i.                 | n.i.                       | n.i.                        |
|                  | 08  | 1                   | 0    | 0          | 1    | 0     | 250                  | 15                | 1000               | 7                  | 0,0213                | 34,17               | n.i.                 | n.i.           | n.i.                 | n.i.                       | n.i.                        |
|                  | 09  | 1                   | 0    | 0          | 1    | 0     | 250                  | 15                | 1000               | 7                  | 0,0381                | 46,31               | n.i.                 | n.i.           | n.i.                 | n.i.                       | n.i.                        |
| Unpublished data | 01  | 1                   | 0    | 0          | 0    | 1     | 250                  | 0                 | 1000               | 6                  | 0,0160                | 52,06               | 52,06                | 307            | 106,0                | 200                        | 200                         |
|                  | 02  | 1                   | 0    | 0          | 0    | 1     | 250                  | 0                 | 1000               | 6                  | 0,0161                | 50,12               | 50,12                | no data        | 52,2                 | 144                        | 144                         |
|                  | 03  | 1                   | 0    | 0          | 0    | 1     | 250                  | 0                 | 1000               | 6                  | 0,0162                | 51,80               | 51,80                | 155            | 55,8                 | 138                        | 138                         |
|                  | 04  | 1                   | 0    | 0          | 0    | 1     | 250                  | 0,8               | 1000               | 6                  | 0,0160                | 55,03               | 55,03                | 254            | 34,8                 | 103                        | 103                         |
|                  | 05  | 1                   | 0    | 0          | 0    | 1     | 250                  | 0,8               | 1000               | 6                  | 0,0161                | 49,14               | 49,14                | no data        | 90,1                 | 168                        | 168                         |
|                  | 06  | 1                   | 0    | 0          | 0    | 1     | 250                  | 0,8               | 1000               | 6                  | 0,0162                | 50,82               | 50,82                | 181            | 29,4                 | 110                        | 110                         |
|                  | 07  | 1                   | 0    | 0          | 1    | 0     | 250                  | 0                 | 1000               | 6                  | 0,0054                | 13,44               | 13,44                | 290            | 25,5                 | 225                        | 225                         |
|                  | 08  | 1                   | 0    | 0          | 1    | 0     | 250                  | 0                 | 1000               | 6                  | 0,0063                | 15,36               | 15,36                | 234            | 15,6                 | 185                        | 185                         |
|                  | 09  | 1                   | 0    | 0          | 1    | 0     | 250                  | 0                 | 1000               | 6                  | 0,0136                | 53,00               | 53,00                | 150            | 13,0                 | 172                        | 172                         |
|                  | 10  | 1                   | 0    | 0          | 1    | 0     | 250                  | 0                 | 1000               | 6                  | 0,0164                | 49,77               | 49,77                | 64             | 4,1                  | 121                        | 121                         |
|                  | 11  | 1                   | 0    | 0          | 1    | 0     | 250                  | 0                 | 1000               | 6                  | 0,0234                | 68,79               | 68,79                | 81             | 19,8                 | 234                        | 234                         |
|                  | 12  | 1                   | 0    | 0          | 1    | 0     | 250                  | 0                 | 1000               | 6                  | 0,0279                | 64,62               | 64,62                | 44             | 10,9                 | 209                        | 209                         |
|                  | 13  | 1                   | 0    | 0          | 1    | 0     | 250                  | 0,8               | 1000               | 6                  | 0,0054                | 16,46               | 16,46                | 212            | 25,5                 | 335                        | 335                         |
|                  | 14  | 1                   | 0    | 0          | 1    | 0     | 250                  | 0,8               | 1000               | 6                  | 0,0063                | 16,19               | 16,19                | 177            | 20,4                 | 242                        | 242                         |
|                  | 15  | 1                   | 0    | 0          | 1    | 0     | 250                  | 0,8               | 1000               | 6                  | 0,0136                | 53,78               | 53,78                | 141            | 7,9                  | 174                        | 174                         |
|                  | 16  | 1                   | 0    | 0          | 1    | 0     | 250                  | 0,8               | 1000               | 6                  | 0,0164                | 49,14               | 49,14                | 74             | 4,3                  | 129                        | 129                         |
|                  | 17  | 1                   | 0    | 0          | 1    | 0     | 250                  | 0,8               | 1000               | 6                  | 0,0234                | 68,37               | 68,37                | 95             | 20,7                 | 257                        | 257                         |
|                  | 18  | 1                   | 0    | 0          | 1    | 0     | 250                  | 0,8               | 1000               | 6                  | 0,0279                | 61,04               | 61,04                | 24             | 3,0                  | 164                        | 164                         |
|                  | 19  | 1                   | 0    | 0          | 1    | 0     | 250                  | 60                | 31                 | 6                  | 0,0139                | 55,71               | 55,71                | 133            | 1,9                  | 196                        | 196                         |
|                  | 20  | 0                   | 1    | 0          | 0    | 1     | 250                  | 1260              | 12                 | 6                  | 0,0160                | 55,70               | 55,70                | 139            | 16,7                 | 35                         | 35                          |
|                  | 21  | 0                   | 1    | 0          | 0    | 1     | 250                  | 1260              | 12                 | 6                  | 0,0161                | 48,95               | 48,95                | no data        | 16,0                 | 51                         | 51                          |
|                  | 22  | 0                   | 1    | 0          | 0    | 1     | 250                  | 1260              | 12                 | 6                  | 0,0162                | 48,33               | 48,33                | 113            | 14,8                 | 4                          | 4                           |
|                  | 23  | 0                   | 1    | 0          | 1    | 0     | 250                  | 1260              | 12                 | 6                  | 0,0054                | 17,56               | 17,56                | 242            | 10,0                 | 331                        | 331                         |
|                  | 24  | 0                   | 1    | 0          | 1    | 0     | 250                  | 1260              | 12                 | 6                  | 0,0063                | 14,64               | 14,64                | 219            | 15,1                 | 219                        | 219                         |
|                  | 25  | 0                   | 1    | 0          | 1    | 0     | 250                  | 1260              | 12                 | 6                  | 0,0136                | 52,82               | 52,82                | 104            | 2,7                  | 31                         | 31                          |
|                  | 26  | 0                   | 1    | 0          | 1    | 0     | 250                  | 1260              | 12                 | 6                  | 0,0141                | 54,39               | 54,39                | 135            | 2,7                  | 25                         | 25                          |
|                  | 27  | 0                   | 1    | 0          | 1    | 0     | 250                  | 1260              | 12                 | 6                  | 0,0164                | 51,17               | 51,17                | 51             | 1,4                  | 8                          | 8                           |
|                  | 28  | 0                   | 1    | 0          | 1    | 0     | 250                  | 1260              | 12                 | 6                  | 0,0234                | 67,45               | 67,45                | 71             | 0,5                  | 29                         | 29                          |
|                  | 29  | 0                   | 1    | 0          | 1    | 0     | 250                  | 1260              | 12                 | 6                  | 0,0279                | 62,83               | 62,83                | 37             | 0,7                  | 17                         | 17                          |

Legend: n.i. marks values that are not included, orange fields represent outliers

### **A.3 Publication Overview**

#### **Journal publications**

Meyn, T., Bahn, A., Leiknes, T., (2008). Significance of flocculation for NOM removal by coagulation - ceramic membrane microfiltration. *Water Science and Technology: Water Supply* 8 (6), 691-700.

Meyn, T., Leiknes, T., (2010). Comparison of optional process configurations and operating conditions for ceramic membrane MF coupled with coagulation/flocculation pre-treatment for the removal of NOM in drinking water production. *Journal of Water Supply: Research and Technology - Aqua* 59 (2-3), 81-91.

Meyn, T., Altmann, J., Leiknes, T., Direct surface water treatment with coagulation/ceramic microfiltration - Minimisation of flocculation pre-treatment. (Accepted for publication in *Desalination and Water Treatment* in January 2011)

Meyn, T., König, A., Leiknes, T., MS2 removal and process performance of a coagulation / flocculation ceramic microfiltration treatment scheme for production of potable water from high NOM content surface water sources. (Submitted to the *Journal of the American Institute of Chemical Engineers* in November 2010)

#### **Oral conference presentations / conference papers**

Meyn, T., Leiknes, T., Ødegaard, H., (2007). Coagulation / flocculation - ceramic membrane filtration for removal of natural organic matter (NOM) under Norwegian conditions. Presented at the 4<sup>th</sup> IWA International Membranes Conference: Membranes for Water and Wastewater Treatment, 15. to 17. May 2007, Harrogate, UK

Meyn, T., Leiknes, T., Ødegaard, H., (2007). NOM removal by ceramic membrane filtration coupled with coagulation / flocculation pretreatment. Presented at the Workshop on ceramic membranes, 24. September 2007 in Nieuwegein, Holland at the KIWA centre for Water Research

Meyn, T., König, A., Leiknes, T., (2008). Hygienic barrier efficiency of a coupled coagulation / flocculation and ceramic microfiltration system for potable water production. Presented at the International Congress on Membranes and Membrane Processes, 12. to 18. May 2008, Honolulu, USA

Meyn, T., Bahn, A., Leiknes, T., (2008). Significance of flocculation for NOM removal by coagulation - ceramic membrane microfiltration. Presented at the 4<sup>th</sup> IWA Specialist Conference “Natural Organic Matter: from Source to Tap”, 2. to 4. September in Bath, UK

Meyn, T., Leiknes, T., (2009). Coagulation / flocculation - microfiltration, an alternative process for the production of potable water? Presented at the International WISA Membrane Technology Conference organised by the Water Institute of Southern Africa, Membrane Technology Division, 12. to 15. May 2009, Stellenbosch, South Africa

Meyn, T., Leiknes, T., (2009). A coupled coagulation - ceramic microfiltration system for potable water production. Presented at the conference Advanced Membrane Technology IV: Membranes for Clean and Sustainable Processes, 7. to 12. June, Trondheim, Norway

Meyn, T., Altmann, J., Leiknes, T., (2010). Direct surface water treatment with coagulation/ceramic microfiltration - Minimisation of flocculation pre-treatment. Presented at the 9<sup>th</sup> conference on Membranes in the Production of Drinking and Industrial Water (MDIW), 27. to 30. June, Trondheim, Norway

Meyn, T., Leiknes, T., (2010). How much flocculation pretreatment is required? Optimizing NOM removal with coagulation / ceramic microfiltration. Presented at the 7<sup>th</sup> International Membrane Science and Technology Conference, 22. to 26.11. 2010, Sydney, Australia

#### **Poster publications**

Meyn, T., Yamamura, H., Kimura, K., Leiknes, T., Watanabe, Y., (2009). Membrane fouling in a coupled coagulation - ceramic microfiltration system caused by natural organic matter. Presented at the 5<sup>th</sup> IWA Specialised Membrane Technology Conference for Water and Wastewater Treatment, 1. to 3. September, Beijing, China

#### A.4 Sammendrag (Abstract in Norwegian)

Overflatevann er en vanlig kilde for produksjonen av drikkevann i Norden. Slikt vann kan vanligvis karakteriseres ved høyt innhold av naturlig organisk stoff (NOM). Det resulterer i høyt fargetall, lav turbiditet, lav alkalitet og hardhet på grunn av de naturlige forholdene. I slike tilfeller inkluderer vannbehandling vanligvis fjerning av NOM og farge, korrosjonskontroll og desinfisering. Selv om NOM i hovedsak er ufarlig, kan noen fraksjoner forårsake farge, lukt eller smaksproblemer, eller kan endog være helseskadelig. Andre problemer relatert til NOM er dannelsen av kompleks med tungmetaller eller skadelige organiskeforbindelser slik at disse blir mer tilgjengelig i vannfasen, eller økning i nødvendig dose av desinfeksjonsmiddel, samt være en forløper til desinfeksjonsbiprodukter som kan være kreftfremmende. Derfor er fjerning av NOM en av de viktigste oppgavene som gjør avansert vannbehandling/rensing nødvendig. Det er også bekymringsfullt at NOM innholdet i naturlige vannkilder har økt de siste dekadene, og i henhold til nyere undersøkelser antagelig vil fortsette å øke som følge av pågående klima endringer.

Konvensjonelle prosesser slik som koagulering / hurtig sandfiltrering eller filtrering med nanofiltrerings (NF) membraner direkte, har vært brukt med suksess. Likevel har man erfart en del ulemper. Så lenge koaguleringsprosessen er optimal er filtratkvaliteten god, men den kan bli kompromittert hvis koaguleringen feiler eller driften er ustabil. En del NF membranlegg har hatt problemer med permanent beleggdannelse (fouling). Problemer med høyt trykk selv ved lav fluks, tap av permeabilitet med tiden og høyt forbruk av kjemikalier for rengjøring av membranene er ofte observert i praksis. I motsetning, unngår lavtrykks-membranfiltrering flere av disse problemene og er blitt et voksende alternativ for direkte rensning av overflatevann Bruken av denne typen membranprosess fører til en høy og stabil permeatkvalitet sammenlignet med de konvensjonelle teknologiene, spesielt med hensyn til hygieniske aspekter siden vannbårne parasitter og de fleste bakterier kan holdes tilbake. Ved å benytte keramiske mikrofiltreringsmembraner (MF) er det mulig å drive rensprosessen mer energi effektivt, hvor høyere investeringskostnader for keramiske membraner kunne utlignes gjennom driften med betydelig høyere fluks. Slike membraner trenger imidlertid koagulering som forbehandling for å sikre tilfredsstillende fjerning av humus og farge, for å bli en tilfredsstillende hygienisk barriere, men også for å kontrollere beleggdannelse på grunn av NOM.

Denne undersøkelsen viste at koagulering sammen med påfølgende keramisk MF er et vellykket konsept for direkte rensning av overflatevann i Norden. Stabil drift ble demonstrert med høye flukser opp til 250 L/(m<sup>2</sup> h), og til tross for høye humuskonsentrasjoner i råvannet (DOC 6.8 mg C/L, fargetall 55 mg Pt/L) var beleggannelsen liten, under 1 mbar/h. Samtidig ble det oppnådd DOC fjerning på mer

enn 70% og farge fjerning på omkring 90% (ved bruk av PACl som koagulant med dose på 0.65 mg Al per mg DOC ved pH 6 og etter 60s rør flokkulering). Fjerning av humus var bare avhengig av koagulantdosen og pH verdien, mens beleggdannelsen på membranene også var avhengig av type flokkulering, flokkuleringstiden, samt G-verdien. Optimalisering av koaguleringsprosessen er absolutt kritisk. Hvis for eksempel utilstrekkelig mengde koagulant doseres, vil det medføre drastisk forhøyet beleggdannelse på membranen, humusfjerning ville være lav og restmetallkonsentrasjonen i rensset vann ville være høy. Enkel statisk miksing sammen med rørflokkulering viste lovende resultater sammenlignet med konvensjonell tank koagulering/flokkulering, hvor permanent membranbeleggdannelse var i samme størrelsesorden for begge flokkuleringsbetingelsene. Likevel var den temporære beleggdannelsen betydelig lavere etter tank koagulering og flokkulering, til tross for knusing av fnokkene i pumpen som føder membranene. Dette indikerer at enten har de knuste fnokkene betydelig forskjellige egenskaper enn de ferske skapte fnokkene, eller så kan fnokkene vokse igjen etter at de har passert pumpen og rukket fram til membrankappilarene.





# References

Abrahamsson, J., Eriksson, U., Milton, G., Clement, J., Rogalla, K., Hattori, K., Yambe, K., (2007). Ceramic Membranes and Coagulation for TOC Removal from Surface Water, in: Hahn, H.H., Hoffman, E., Ødegaard, H. (Eds.), 12th Gothenburg Symposium 2007, IX ed. IWA Publishing, Ljubljana, Slovenia.

Antelmi, D., Cabane, B., Meireles, M., Aimar, P., (2001). Cake collapse in pressure filtration. *Langmuir* 17 (22), 7137-7144.

Aoustin, E., Schafer, A.I., Fane, A.G., Waite, T.D., (2001). Ultrafiltration of natural organic matter. *Separation and Purification Technology* 22-3 (1-3), 63-78.

Archer, A.D., Singer, P.C., (2006). An evaluation of the relationship between SUVA and NOM coagulation using the ICR database. *Journal American Water Works Association* 98 (7), 110-123.

Austnes, K., (2008). Effects of climatic factors on production and leaching of dissolved organic matter (DOM) in heathland systems, Department of Plant and Environmental Sciences, Norwegian University of Life Sciences, Ås.

Azrague, K., Østerhus, S., Leiknes, T., (2009). Development and evaluation of a new concept for drinking water treatment: the OBM process. IWA Publishing, London, UK. ISBN: 9-781-84-33927-50.

Bartel, H., (2002). Aufbereitung von Wasser, in: Grohmann, A. (Ed.), *Wasser: Nutzung im Kreislauf, Hygiene, Analyse und Bewertung* / Karl Höll. Walter de Gruyter & Co., Berlin. ISBN: 3-11-012931-0.

- Beckett, R., Le, N.P., (1990). THE ROLE OF ORGANIC-MATTER AND IONIC COMPOSITION IN DETERMINING THE SURFACE-CHARGE OF SUSPENDED PARTICLES IN NATURAL-WATERS. *Colloids and Surfaces* 44, 35-49.
- Bolto, B., Abbt-Braun, G., Dixon, D., Eldridge, R., Frimmel, F., Hesse, S., King, S., Toifl, M., (1999). Experimental evaluation of cationic polyelectrolytes for removing natural organic matter from water. *Water Science and Technology* 40 (9), 71-79.
- Bolto, B., Dixon, D., Eldridge, R., King, S., (2001). Cationic polymer and clay or metal oxide combinations for natural organic matter removal. *Water Research* 35 (11), 2669-2676.
- Bolto, B., Gregory, J., (2007). Organic polyelectrolytes in water treatment. *Water Research* 41 (11), 2301-2324.
- Bottero, J.Y., Bersillon, J.L., (1989). ALUMINUM AND IRON(III) CHEMISTRY - SOME IMPLICATIONS FOR ORGANIC-SUBSTANCE REMOVAL. *AcS Symposium Series* 219, 425-442.
- Brandt, J., (2010). Direct filtration of humicsurface water using 3-media filter with alkaline filter material, 7th Nordic Drinkingwater Conference, Copenhagen, Denmark.
- Bratby, J., (2006). *Coagulation and Flocculation in Water and Wastewater Treatment*, Second edition ed. IWA Publishing, London, UK. ISBN: 978-1-84-339106-7.
- Cabane, B., Meireles, M., Aimar, P., (2002). Cake collapse in frontal filtration of colloidal aggregates: mechanisms and consequences. *Desalination* 146 (1-3), 155-161.
- Camp, T.R., Stein, P.C., (1943). Velocity gradients and internal work in fluid in motion. *Journal of the Boston Society of Civil Engineers* Section 30 (4), 219-237.
- Carroll, T., King, S., Gray, S.R., Bolto, B.A., Booker, N.A., (2000). The fouling of microfiltration membranes by NOM after coagulation treatment. *Water Research* 34 (11), 2861-2868.

---

Cho, J., Amy, G., Pellegrino, J., (2000). Membrane filtration of natural organic matter: factors and mechanisms affecting rejection and flux decline with charged ultrafiltration (UF) membrane. *Journal of Membrane Science* 164 (1-2), 89-110.

Cho, M.H., Lee, C.H., Lee, S., (2006). Effect of flocculation conditions on membrane permeability in coagulation-microfiltration. *Desalination* 191 (1-3), 386-396.

Chow, C.W.K., Fabris, R., Drikas, M., (2004). A rapid fractionation technique to characterise natural organic matter for the optimisation of water treatment processes. *Journal of Water Supply Research and Technology-Aqua* 53 (2), 85-92.

Cleasby, J.L., Logsdon, G.S., (1999). Granular bed and precoat filtration, in: Letterman, R.D. (Ed.), *Water Quality and Treatment*. McGraw Hill, New York, pp. 8.1 - 8.99.

Crittenden, J.C., Trussell, R.R., Hand, D.W., Howe, K.J., Tchobanoglous, G., (2005). *Water Treatment: Principles and Design*. John Wiley & Sons, Hoboken, New Jersey, USA. ISBN: 0-471-11018-3.

Crozes, G., Anselme, C., Mallevalle, J., (1993). EFFECT OF ADSORPTION OF ORGANIC-MATTER ON FOULING OF ULTRAFILTRATION MEMBRANES. *Journal of Membrane Science* 84 (1-2), 61-77.

Davis, M.L., (2010). *Water and Wastewater Engineering*. McGraw - Hill, New York. ISBN: 978-0-07-171384-9.

Doyen, W., (1997). Latest developments in ultrafiltration for large-scale drinking water applications. *Desalination* 113 (2-3), 165-177.

Duan, J.M., Gregory, J., (2003). Coagulation by hydrolysing metal salts. *Advances in Colloid and Interface Science* 100, 475-502.

Edwards, G.A., Amirtharajah, A., (1985). REMOVING COLOR CAUSED BY HUMIC ACIDS. *Journal American Water Works Association* 77 (3), 50-57.

Edzwald, J.K., Tobiasson, J.E., (1999). Enhanced coagulation: US requirements and a broader view. *Water Science and Technology* 40 (9), 63-70.

Eikebrokk, B., (1996). Removal of humic substances by coagulation, in: Hahn, H.H., Hoffman, E., Ødegaard, H. (Eds.), *Chemical Water and Wastewater Treatment IV*. Springer-Verlag, Berlin, Heidelberg, pp. 173-187. ISBN: ISBN 3-540-61624-1.

Eikebrokk, B., (1999). Coagulation-direct filtration of soft, low alkalinity humic waters. *Water Science and Technology* 40 (9), 55-62.

Eikebrokk, B., (2000). Effects of Coagulant Type and Coagulation Conditions on NOM Removal from Drinking Water, in: Hahn, H.H., Hoffman, E., Ødegaard, H. (Eds.), *Chemical Water and Wastewater Treatment VI*. Springer Verlag, Berlin, Heidelberg, pp. 211-220. ISBN: 3-540-67574-4.

Eikebrokk, B., (2004). NOM increase in Northern European source waters: Impacts on coagulation and filtration processes, *NOM Innovations and Applications*, 2-5 March, Victor Harbor, Adelaide, Australia.

Eikebrokk, B., Juhna, T., Østerhus, S., (2006). Water treatment by enhanced coagulation – Operational status and optimization issues, *Techneau*, D 5.3.1., <http://www.techneau.org/index.php?id=120>

Elimelech, M., Gregory, J., Jia, X., Williams, R., (1995). *Particle deposition and aggregation - measurement modelling, simulation*. Butterworth-Heinemann, Oxford.

Emelko, M.B., Huck, P.M., Douglas, I.P., (2003). Cryptosporidium and microsphere removal during late in-cycle filtration. *Journal American Water Works Association* 95 (5), 173-182.

Esbensen, K.H., (2002). *Multivariate Data Analysis - In Practise*, 5<sup>th</sup> ed. CAMO Process AS, Oslo, Norway. ISBN: 82-993330-3-2.

Fan, L.H., Harris, J.L., Roddick, F.A., Booker, N.A., (2001). Influence of the characteristics of natural organic matter on the fouling of microfiltration membranes. *Water Research* 35 (18), 4455-4463.

---

Fettig, J., (1999). Removal of humic substances by adsorption/ion exchange. *Water Science and Technology* 40 (9), 173-182.

Gillberg, L., Hansen, B., Karlsson, I., Enkel, A.N., Pålsson, A., (2003). About water treatment. Kemira Kemwater, Helsingborg, Sweden. ISBN: 91-631-4344-5.

Gray, S.R., Ritchie, C.B., Tran, T., Bolto, B.A., (2007). Effect of NOM characteristics and membrane type on microfiltration performance. *Water Research* 41 (17), 3833-3841.

Gregor, J.E., Nokes, C.J., Fenton, E., (1997). Optimising natural organic matter removal from low turbidity waters by controlled pH adjustment of aluminium coagulation. *Water Research* 31 (12), 2949-2958.

Gregory, J., (2006). *Particles in Water: Properties and Processes*. CRC Press, Boca Raton, USA, IWA Publishing, London, UK.

Gregory, J., Dupont, V., (2001). Properties of flocs produced by water treatment coagulants. IWA Publishing, pp. 231-236.

Gregory, J., Nelson, D.W., (1986). MONITORING OF AGGREGATES IN FLOWING SUSPENSIONS. *Colloids and Surfaces* 18 (2-4), 175-188.

Guigui, C., Rouch, J.C., Durand-Bourlier, L., Bonnelye, V., Aptel, P., (2002). Impact of coagulation conditions on the in-line coagulation/UF process for drinking water production. *Desalination* 147 (1-3), 95-100.

Hall, E.S., Packham, R.F., (1965). Coagulation of organic color with hydrolyzing coagulants. *Journal American Water Works Association* 57 (Sept.), 1149-1166.

Hallé, C., Huck, P.M., Peldszus, S., Haberkamp, J., Jekel, M., (2009). Assessing the Performance of Biological Filtration As Pretreatment to Low Pressure Membranes for Drinking Water. *Environmental Science & Technology* 43 (10), 3878-3884.

Hammersland, R., (2009). Erfaring med felling og moldeprosessanlegg, VA-dagene på Vestlandet. Bergen Vann KF, Voss, Norway.

- Heijman, B., Bakker, S., (2007). Ceramic micro filtration as the first treatment step in surface water treatment, Techneau, 2.3.2.1, <http://www.techneau.org/index.php?id=120>
- Hem, L.J., (2008). Nanofiltration for removal of humic substances: Survey on operational strategies, Techneau, D 5.3.5B, <http://www.techneau.org/index.php?id=120>
- Hendricks, D.W., (2006). Water Treatment Unit Processes: Physical and Chemical. CRC Press, Tayler & Francis Group, Boca Raton.
- Hong, S.K., Elimelech, M., (1997). Chemical and physical aspects of natural organic matter (NOM) fouling of nanofiltration membranes. Journal of Membrane Science 132 (2), 159-181.
- Howe, K.J., Clark, M.M., (2002). Fouling of microfiltration and ultrafiltration membranes by natural waters. Environmental Science & Technology 36 (16), 3571-3576.
- Howe, K.J., Clark, M.M., (2006). Effect of coagulation pretreatment on membrane filtration performance. Journal American Water Works Association 98 (4), 133-146.
- Howe, K.J., Marwah, A., Chiu, K.P., Adham, S.S., (2006). Effect of coagulation on the size of MF and UF membrane foulants. Environmental Science & Technology 40 (24), 7908-7913.
- Hundt, T.R., Omelia, C.R., (1988). ALUMINUM FULVIC ACID INTERACTIONS - MECHANISMS AND APPLICATIONS. Journal American Water Works Association 80 (4), 176-186.
- IPCC, (2007). Summary for Policymakers. In: Climate Change 2007: The Physical Science Basis. Contribution of Working Group I to the Fourth Assessment Report of the Intergovernmental Panel on Climate Change, Cambridge University Press, Cambridge, United Kingdom and New York, NY, USA.,

Jacangelo, J.G., Adham, S.S., Laine, J.M., (1995). MECHANISM OF CRYPTOSPORIDIUM, GIARDIA, AND MS2 VIRUS REMOVAL BY MF AND UF. *Journal American Water Works Association* 87 (9), 107-121.

Jarvis, P., Jefferson, B., Parsons, S.A., (2005). How the natural organic matter to coagulant ratio impacts on floc structural properties. *Environmental Science & Technology* 39 (22), 8919-8924.

Jekel, M., Gimbel, R., Ließfeld, R., (2004). *Wasseraufbereitung - Grundlagen und Verfahren*. R. Oldenbourg Verlag. ISBN: 3-486-26365-X.

Jekel, M.R., (1986). THE STABILIZATION OF DISPERSED MINERAL PARTICLES BY ADSORPTION OF HUMIC SUBSTANCES. *Water Research* 20 (12), 1543-1554.

Jekel, M.R., Heinzmann, B., (1989). RESIDUAL ALUMINUM IN DRINKING-WATER TREATMENT. *Aqua (Oxford)* 38 (5), 281-288.

Jiang, J.Q., Graham, N.J.D., Harward, C., (1996). Coagulation of upland coloured water with polyferric sulphate compared to conventional coagulants. *Journal of Water Supply Research and Technology-Aqua* 45 (3), 143-154.

Johnson, P.N., Amirtharajah, A., (1983). FERRIC-CHLORIDE AND ALUM AS SINGLE AND DUAL COAGULANTS. *Journal American Water Works Association* 75 (5), 232-239.

Jones, K.L., O'Melia, C.R., (2001). Ultrafiltration of protein and humic substances: effect of solution chemistry on fouling and flux decline. *Journal of Membrane Science* 193 (2), 163-173.

Jucker, C., Clark, M.M., (1994). ADSORPTION OF AQUATIC HUMIC SUBSTANCES ON HYDROPHOBIC ULTRAFILTRATION MEMBRANES. *Journal of Membrane Science* 97, 37-52.

- Judd, S.J., Hillis, P., (2001). Optimisation of combined coagulation and microfiltration for water treatment. *Water Research* 35 (12), 2895-2904.
- Kaastrup, E., Halmo, T.M., (1989). REMOVAL OF AQUATIC HUMUS BY OZONATION AND ACTIVATED-CARBON ADSORPTION. *Acs Symposium Series* 219, 697-726.
- Kam, S.K., Gregory, J., (2001). The interaction of humic substances with cationic polyelectrolytes. *Water Research* 35 (15), 3557-3566.
- Kennedy, M., Kamanyi, J., Salinas Rodriguez, S.G., Lee, N.H., Schippers, J.C., Amy, G., (2008). Water Treatment by Microfiltration and Ultrafiltration, in: Li, N.N., Fane, A.G., Ho, W.S.W., Matsuura, T. (Eds.), *Advanced Membrane Technology and Applications*. John Wiley & Sons, Hoboken, New Jersey, USA. ISBN: 978-0-471-73167-2.
- Kim, S., Park, N.S., Kim, T., Park, H., (2007). Reaggregation of flocs in coagulation-cross-flow microfiltration. *Journal of Environmental Engineering-Asce* 133 (5), 507-514.
- Konieczny, K., Bodzek, M., Rajca, M., (2006). A coagulation - MF system for water treatment using ceramic membranes. *Desalination* 198 (1-3), 92-101.
- Krasner, S.W., Amy, G., (1995). JAR-TEST EVALUATIONS OF ENHANCED COAGULATION. *Journal American Water Works Association* 87 (10), 93-107.
- Kubota, N., Hashimoto, T., Mori, Y., (2008). Microfiltration and Ultrafiltration, in: Li, N.N., Fane, A.G., Ho, W.S.W., Matsuura, T. (Eds.), *Advanced Membrane Technology and Applications*. John Wiley & Sons, Hoboken, New Jersey, USA. ISBN: 978-0-471-73167-2.
- Kvinnesland, T., Ødegaard, H., (2004). The effects of polymer characteristics on nano particle separation in humic substances removal by cationic polymer coagulation. *Water Science and Technology* 50 (12), 185-191.



- 
- Lahoussine-Turcaud, V., Wiesner, M.R., Bottero, J.Y., Mallevalle, J., (1990). Coagulation Pretreatment for Ultrafiltration of a Surface-Water. *Journal American Water Works Association* 82 (12), 76-81.
- Lainé, J.M., Hagstrom, J.P., Clark, M.M., Mallevalle, J., (1989). EFFECTS OF ULTRAFILTRATION MEMBRANE-COMPOSITION. *Journal American Water Works Association* 81 (11), 61-67.
- Lee, J.D., Lee, S.H., Jo, M.H., Park, P.K., Lee, C.H., Kwak, J.W., (2000). Effect of coagulation conditions on membrane filtration characteristics in coagulation-microfiltration process for water treatment. *Environmental Science & Technology* 34 (17), 3780-3788.
- Lee, S., Cho, J., (2004). Comparison of ceramic and polymeric membranes for natural organic matter (NOM) removal. *Desalination* 160 (3), 223-232.
- Leiknes, T., Ødegaard, H., Myklebust, H., (2004). Removal of natural organic matter (NOM) in drinking water treatment by coagulation-microfiltration using metal membranes. *Journal of Membrane Science* 242 (1-2), 47-55.
- Lerch, A., (2008). Fouling layer formation by flocs in inside-out driven capillary ultrafiltration membranes, Faculty of engineering sciences, department for mechanical engineering. Doctoral thesis, University of Duisburg-Essen, Duisburg.
- Lerch, A., Panglisch, S., Buchta, P., Tomitac, Y., Yonekawa, H., Hattori, K., Gimbel, R., (2005a). Direct river water treatment using coagulation/ceramic membrane microfiltration. *Desalination* 179 (1-3), 41-50.
- Lerch, A., Panglisch, S., Gimbel, R., (2005b). Research experiences in direct potable water treatment using coagulation/ultrafiltration. *Water Science and Technology* 51 (6-7), 221-229.
- Lerch, A., Panglisch, S., Nahrstedt, R., Gimbel, R., (2004). The Influence of Temperature on Size and Structure of Flocs in the Hybrid Process

- Coagulation/Ultrafiltration, in: Hahn, H.H., Hoffman, E., Ødegaard, H. (Eds.), 11th Gothenburg Symposium 2004. IWA Publishing, Orlando, Florida, pp. 265 - 276.
- Li, N.N., Fane, A.G., Ho, W.S.W., Matsuura, T., (2008). *Advanced Membrane Technology and Applications*. John Wiley & Sons, Hoboken, New Jersey.
- Lin, C.F., Lin, T.Y., Hao, O.J., (2000). Effects of humic substance characteristics on UF performance. *Water Research* 34 (4), 1097-1106.
- Loi-Brügger, A., Panglisch, S., Buchta, P., Hattori, K., Yonekawa, H., Tomita, Y., Gimbel, R., (2006). Ceramic membranes for direct river water treatment applying coagulation and microfiltration. *Water science & technology: water supply* 6 (4), 89 - 98.
- Lozier, J., Cappucci, L., Amy, G., Lee, N.H., Jacangelo, J.G., Huang, H., Young, T., Mysore, C., Emaraux, C., Clouet, J., Croue, J.P., Heijman, B., (2008). *Natural Organic Matter Fouling of Low-Pressure Membrane Systems*. AWWA Research Foundation. ISBN: 978-1-60573-007-3.
- Machenbach, I., (2003). *Immersed membranes - Coagulation/submerged hollow-fibre ultrafiltration for NOM removal*. *Water science & technology: water supply* 3 (5), 401.
- Machenbach, I., (2007). *Drinking Water Production by Coagulation and Membrane Filtration*, Department of Hydraulic and Environmental Engineering. Doctoral thesis, Norwegian University of Science and Technology, Trondheim.
- Machenbach, I., Thorsen, T., (2006). *Nanofiltration of NOM-rich surface water in Norway*, Workshop: Ultra- and Nanofiltration in Water Treatment, RWTH Aachen, Germany.
- Makdissy, G., Croue, J.P., Buisson, H., Amy, G., Legube, B., (2003). Fouling - Organic matter fouling of ultrafiltration membranes. *Water science & technology: water supply* 3 (5-6), 175.

Martens, H., Næs, T., (1989). *Multivariate Calibration*. John Wiley & Sons Ltd., Chichester, UK.

Melin, E., Eikebrokk, B., Brugger, M., Ødegaard, H., (2002). Treatment of humic surface water at cold temperatures by ozonation and biofiltration. *Water science & technology: water supply* 2 (5), 451-457.

Melin, T., Rautenbach, R., (2004). *Membranverfahren - Grundlagen der Modul- und Anlagenauslegung*, 2. Aufl. ed. Springer Verlag Berlin Heidelberg New York. ISBN: 3-540-00071-2.

Morris, J.K., Knocke, W.R., (1984). TEMPERATURE EFFECTS ON THE USE OF METAL-ION COAGULANTS FOR WATER-TREATMENT. *Journal American Water Works Association* 76 (3), 74-79.

Mulder, M., (1996). *Basic principles of membrane technology*. Springer Verlag. ISBN: 978-0792342489.

Myrstad, L., Nordheim, C.F., Einan, B., (2010). *Vannrapport 114: Rapport fra Vanverksregisteret – Drikkevannsstatus (data 2005 og 2006)*, Nasjonalt folkehelseinstitutt, Oslo, Norway

Nieminski, E.C., Ongerth, J.E., (1995). REMOVING GIARDIA AND CRYPTOSPORIDIUM BY CONVENTIONAL TREATMENT AND DIRECT-FILTRATION. *Journal American Water Works Association* 87 (9), 96-106.

Norwegian Ministry of Health and Care Services, (2001). *Forskrift om vannforsyning og drikkevann (Drikkevannsforskriften)*, FOR-2001-12-04-1372, effective date 2002-01-01, last revision 2010-01-03.

Panglisch, S., Dautzenberg, W., Holy, A., (2008). Drinking water treatment with combined coagulation ultrafiltration - long term experience with Germany's largest plant. *Water science & technology: water supply* 8 (4), 363 - 375.

- Panglisch, S., Kraus, G., Tatzel, A., Lickes, J.P., (2010). Membrane performance in combined processes including ozonation or advanced oxidation, powdered activated carbon and coagulation - Investigations in pilot scale. *Desalination* 250 (2), 819-823.
- Pernitsky, D.J., Edzwald, J.K., (2006). Selection of alum and polyaluminum coagulants: principles and applications. *Journal of Water Supply Research and Technology-Aqua* 55 (2), 121-141.
- Peuchot, M.M., Ben-Aim, R., (1992). Improvement of Cross-Flow Microfiltration Performances with Flocculation. *Journal of Membrane Science* 68 (3), 241-248.
- Pikkarainen, A.T., Judd, S.J., Jokela, J., Gillberg, L., (2004). Pre-coagulations for microfiltration of an upland surface water. *Water Research* 38 (2), 455-465.
- Randtke, S.J., (1988). ORGANIC CONTAMINANT REMOVAL BY COAGULATION AND RELATED PROCESS COMBINATIONS. *Journal American Water Works Association* 80 (5), 40-56.
- Rebhun, M., Fuhrer, Z., Adin, A., (1984). CONTACT FLOCCULATION FILTRATION OF HUMIC SUBSTANCES. *Water Research* 18 (8), 963-970.
- Saltnes, T., Eikebrokk, B., Odegaard, H., (2002). Coagulation optimisation for NOM removal by direct filtration in clay aggregate filters. *Journal of Water Supply Research and Technology-Aqua* 51 (2), 125-134.
- Sandvik, B., Ødegaard, T.P., (2010). PRAKTISK ERFARING MED KOAGULERING/MEMBRANFILTRERING VED LELLO VANNBEHANDLINGSANLEGG I LEVANGER KOMMUNE, Tekna Kursdagene. Tekna / NTNU, Trondheim, Norway.
- Schulze, S., (1996). Mikroorganismen als alternative Flockungshilfsmittel in der Fest-Flüssig-Trennung. Doctoral thesis, Karlsruhe University, Karlsruhe, p. 215.

---

Schäfer, A.I., Schwicker, U., Fischer, M.M., Fane, A.G., Waite, T.D., (2000). Microfiltration of colloids and natural organic matter. *Journal of Membrane Science* 171 (2), 151-172.

Semmens, M.J., Ayers, K., (1985). REMOVAL BY COAGULATION OF TRACE ORGANICS FROM MISSISSIPPI RIVER WATER. *Journal American Water Works Association* 77 (5), 79-84.

Stumm, W., Morgan, J.J., (1970). *Aquatic Chemistry*. John Wiley & Sons, New York.

Stumm, W., O'Melia, C.R., (1968). Stoichiometry of coagulation. *Journal American Water Works Association* May, 514-539.

Tambo, N., Kamei, T., (1978). TREATABILITY EVALUATION OF GENERAL ORGANIC-MATTER - MATRIX CONCEPTION AND ITS APPLICATION FOR A REGIONAL WATER AND WASTE-WATER SYSTEM. *Water Research* 12 (11), 931-950.

Tambo, N., Kamei, T., Itoh, H., (1989). EVALUATION OF EXTENT OF HUMIC-SUBSTANCE REMOVAL BY COAGULATION. *Acs Symposium Series* 219, 453-471.

Teermann, I.P., Jekel, M.R., (1999). Adsorption of humic substances onto beta-FeOOH and its chemical regeneration. *Water Science and Technology* 40 (9), 199-206.

The Norwegian Institute of Public Health, (2010). Water treatment plant information service, Last access: 08.09.2010, <http://158.36.43.144/VregStat/fmLogin.aspx>

Thorsen, T., (1999). Membrane filtration of humic substances - State of the art. *Water Science and Technology* 40 (9), 105-112.

United States Environmental Protection Agency, (2001). *Low-Pressure Membrane Filtration for Pathogen Removal: Application, Implementation and Regulatory Issues*, Office of Water, 815-C-01-001

van den Broeke, J., Ross, P.S., Edthofer, F., van der Helm, A.W.C., Weingartner, A., Rietveld, L.C., (2009). The versatility of online UV/Vis-spectrometry - an overview. IWA Publishing, London, UK. ISBN: 9-781-84-33927-50.

van der Bruggen, B., Geens, J., (2008). Nanofiltration, in: Li, N.N., Fane, A.G., Ho, W.S.W., Matsuura, T. (Eds.), *Advanced Membrane Technology and Applications*. John Wiley & Sons, Hoboken, New Jersey, USA. ISBN: 978-0-471-73167-2.

Vogelsang, C., (2004). Coagulation/colour removal - Removal of humic substances by chitosan. *Water science & technology: water supply* 4 (5), 121.

Wiechmann, K., (2004). Rückstände aus der Wasseraufbereitung, in: Gimbel, R., Jekel, M., Ließfeld, R. (Eds.), *Wasseraufbereitung - Grundlagen und Verfahren*. Oldenbourg Industrieverlag GmbH, München, Germany. ISBN: 3-486-26365-X.

Wiesner, M.R., Chellam, S., (1992). MASS-TRANSPORT CONSIDERATIONS FOR PRESSURE-DRIVEN MEMBRANE PROCESSES. *Journal American Water Works Association* 84 (1), 88-95.

Wiesner, M.R., Clark, M.M., Mallevalle, J., (1989). MEMBRANE FILTRATION OF COAGULATED SUSPENSIONS. *Journal of Environmental Engineering-Asce* 115 (1), 20-40.

Yamamura, H., Okimoto, K., Kimura, K., Watanabe, Y., (2007). Influence of calcium on the evolution of irreversible fouling in microfiltration/ultrafiltration membranes. *Journal of Water Supply Research and Technology-Aqua* 56 (6-7), 425-434.

Yonekawa, H., Tomita, Y., Watanabe, Y., (2004). Behavior of micro-particles in monolith ceramic membrane filtration with pre-coagulation. *Water Science and Technology* 50 (12), 317-325.

Yoon, S.H., Lee, C.H., Kim, K.J., Fane, A.G., (1998). Effect of calcium ion on the fouling of nanofilter by humic acid in drinking water production. *Water Research* 32 (7), 2180-2186.

---

Yu, W., Gregory, J., Campos, L.C., (2010). Breakage and re-growth of flocs formed by charge neutralization using alum and polyDADMAC. *Water Research* 44 (13), 3959-3965.

Yuan, W., Zydney, A.L., (1999a). Effects of solution environment on humic acid fouling during microfiltration. *Desalination* 122 (1), 63-76.

Yuan, W., Zydney, A.L., (1999b). Humic acid fouling during microfiltration. *Journal of Membrane Science* 157 (1), 1-12.

Zhu, B.T., Clifford, D.A., Chellam, S., (2005). Virus removal by iron coagulation-microfiltration. *Water Research* 39 (20), 5153-5161.

Zouboulis, A.I., Traskas, G., (2005). Comparable evaluation of various commercially available aluminium-based coagulants for the treatment of surface water and for the post-treatment of urban wastewater. *Journal of Chemical Technology and Biotechnology* 80 (10), 1136-1147.

Zularisam, A.W., Ismail, A.F., Salim, R., (2006). Behaviours of natural organic matter in membrane filtration for surface water treatment - a review. *Desalination* 194 (1-3), 211-231.

Ødegaard, H., Brattebø, H., Halle, O., (1989). Removal of humic substances by ion exchange, in: Suffet, I.H., McCarthy, P. (Eds.), *Aquatic humic substances : influence on fate and treatment of pollutants*. American Chemical Society, Washington DC, USA. ISBN: 0-8412-1428-x.

Ødegaard, H., Eikebrokk, B., Storhaug, R., (1999). Processes for the removal of humic substances from water - An overview based on Norwegian experiences. *Water Science and Technology* 40 (9), 37-46.

Ødegaard, H., Østerhus, S., Melin, E., Eikebrokk, B., (2010). NOM removal technologies – Norwegian experiences. *Drinking Water Engineering and Science* 3 (1-9).