



Norwegian University of
Science and Technology

Voltage Control and Provision of Reactive Power Reserves

for Hove and Refsdal Power Stations

Elisabeth Veum

Master of Energy and Environmental Engineering

Submission date: June 2016

Supervisor: Kjetil Uhlen, ELKRAFT

Co-supervisor: Inge Hass, Statkraft

Norwegian University of Science and Technology
Department of Electric Power Engineering

Preface

This master thesis is the final work submitted in order to fulfill the degree Master of Science (MSc) in Electric Power Engineering at the Norwegian University of Science and Technology (NTNU), during spring 2016. The work is a continuation of the former specialization project *Voltage Control and Sharing of Reactive Power*, performed autumn 2015.

I would like to thank my supervisor Professor Kjetil Uhlen, at the Department of Electrical Power Engineering, for his contribution regarding this thesis. His knowledge has been very helpful to understand the different aspects of this topic and to guide my work. I would also like to thank my co-supervisor Inge Hass, in Statkraft Region Midt, for good discussions and for providing information about the system. In addition, I would like to thank both my supervisors for giving me the opportunity to work on this topic.

Kjell Ove Gylland in Hymatek, needs to be mentioned as well, and I would like to thank him for providing data about the AVRs. In addition, both Kjell Ove Gylland and Erik Ongstad in Hymatek as well as Tor Arne Nyhus in Hydro Energi should be thanked for sharing some of their knowledge on the topic. To get my models running in PowerFactory, I received good help from PhD candidate Lester Kalemba, and I would therefore like to thank him for his contribution as well.

Trondheim, June 2016

Elisabeth Veum

Abstract

In this thesis voltage control and provision of reactive power reserves were studied, for multiple generators connected to a common main transformer. The system that was considered consists of two power stations in Vik in Sogn, Hove and Refsdal, which are operated by Statkraft. Each of the power stations has two generators that are connected to the grid through a common transformer. In this thesis voltage control and reactive power should be analyzed, in an attempt to come up with suggestions to how voltage control of paralleled generators might be done. How the AVR's tuning of reactive droop and compensation would affect a power system with generators operating in parallel, and how utilizing different measuring points would affect the regulation, should also be investigated. The voltage drop across the transformers was also considered. In addition, the principles of the current strategy for control were discussed and tested, and Statnett's requirements regarding voltage control and provision of reactive power reserves were evaluated. To perform the different simulations, a simplified model of the actual system was made in the simulation programme DlgSILENT PowerFactory, and various functionalities in the programme were utilized.

It should be mentioned that the voltage at both the generators' terminals and the transformer's grid side should be taken into account when investigating voltage control. It will not be sufficient to only consider the voltage at the terminals, as the transformer reactance will introduce some voltage drop. As a net droop is required on the generators' terminals in order to secure stable operation of paralleled generators, as was proved in the simulations, and the transformer reactance provides some voltage drop, the resulting droop at the transformer's grid side will be a result of both the droop settings as well as the transformer reactance. Hence, the transformer reactance limits how small the resulting droop at the grid side could be.

When studying the voltage drop across the transformers, it was for this system found that the voltage variations at the generators' terminals, and the voltage drop across the transformers, were mainly related to the change in reactive power. The voltage variations were almost unaffected by the active power supply.

The simulations investigating the effect of utilizing measurements from the transformer's grid side showed that there were no clear advantages by using this strategy. The stability was not improved, and the variations in voltage and reactive power remained equally large compared to the case when the measurements were taken from the generators' terminals. It was also found that there could not be a net

compensation at the terminals of the paralleled generators, regardless of what measuring points were utilized. Hence, compensation could not be utilized in order to obtain a constant voltage at the transformer's grid side, when operating multiple generators connected to a common transformer. Consequently, a net droop must be applied at the generators for such cases, as mentioned above.

The investigation of the AVR's tuning of reactive droop and compensation for one generator operating alone, showed that the generators might be able to contribute to improve the overall voltage control in the system. For a single operated generator compensation could be applied, and hence a more constant voltage might be obtained at the transformer's secondary side, dependent on the grid in which the generator is connected.

The simulations investigating tuning of the AVRs, with respect to various voltage intervals, showed that the droop settings should be adjusted to suitable voltage ranges in order to improve the regulation. In today's system, the droop at the generators in Hove and Refsdal is of 5% and 10% respectively. But when considering the control procedure utilized, adjusting the reactive set point, the resulting droop at the secondary side is of about 33% in Hove and 38% in Refsdal. These droops are large, and the generators would consequently not provide much of a contribution to voltage and reactive power control. In order to obtain a better tuning of the AVRs, the power producer must first determine what voltage variations the droop should be adjusted to. If the power producer wants to avoid changing the set point for voltage or reactive power, even when large voltage variations are considered, a large droop is needed. On the other hand, if a smaller voltage range is considered, a larger contribution to voltage and reactive power control could be given if the droop is reduced. As mentioned above, the resulting droop on the grid side will be dependent on both the droop at the generators and the transformer voltage drop.

It should also be mentioned that Statnett's requirements for voltage control and provision of reactive power reserves might be difficult for the power producers to meet, when operating paralleled generators. The simulations and analytical evaluations indicated that the resulting droop at the transformers' grid side were larger than what was found considering these requirements, due to the transformer reactance. In order to meet Statnett's demands the power producers operating paralleled generators might have to utilize control strategies that adjusts the AVR's set points, e.g. through a secondary control loop. Still, Statnett's requirements regarding voltage and reactive power control, and the cooperation between Statnett and the power producers, should be studied further, in order to approach the challenges related to the overall voltage control and system support of reactive power.

Sammendrag

I denne masteroppgaven ble spenningsregulering og forsyning av reaktiv effekt studert for tilfeller der flere generatorer er tilknyttet en felles hovedtransformator. Systemet som ble studert består av to kraftstasjoner i Vik i Sogn, Hove og Refsdal, som er drevet av Statkraft. Hver av kraftstasjonene har to generatorer som er koblet til kraftnettet via en felles transformator. I denne masteroppgaven skulle spenningsregulering og reaktiv effekt analyseres, i et forsøk på å komme med forslag til hvordan spenningsregulering av parallelle generatorer kan gjøres. Hvordan spenningsregulatorens innstillinger for reaktiv statikk og kompensasjon ville påvirke et kraftsystem med parallelle generatorer, og hvordan bruk av ulike målepunkter ville påvirke reguleringen, skulle også undersøkes. Spenningsfallet over transformatorene ble også vurdert. I tillegg ble prinsippene ved den nåværende reguleringsmetoden diskutert og testet, og Statnetts krav i forhold til spenningsregulering og bidrag med reaktiv effekt ble evaluert. For å gjøre de ulike simuleringene ble en forenklet modell av det faktiske systemet laget i simuleringprogrammet DIGSILENT PowerFactory, og ulike funksjoner i programmet ble benyttet.

Det burde nevnes at spenningen på både generatorenes terminaler og transformatorens høyspentside burde tas i betraktning når spenningsregulering undersøkes. Det vil ikke være tilstrekkelig å bare ta hensyn til spenningen på terminalene, da transformatorreaktansen vil gi et spenningsfall over transformatoren. Siden det er nødvendig å ha en netto reaktiv statikk på generatorenes terminaler for å sikre stabil drift av parallellkoblede generatorer, som vist i simuleringene, og traforeaktansen gir et spenningsfall, vil den resulterende reaktive statikken på transformatorens høyspentside være gitt av både statikkinnstillingene og transformatorreaktansen. Følgelig vil transformatorreaktansen begrense hvor liten den totale statikken på høyspentsiden kan være.

Når spenningsfallet over transformatorene ble studert, ble det for dette systemet observert at spenningsvariasjonene på generatorterminalene, og spenningsfallet over transformatoren, hovedsakelig ble påvirket av den reaktive effekten. Spenningsvariasjonene var nærmest upåvirket av flyten av aktiv effekt.

Simuleringene som undersøkte effekten av å benytte målinger fra transformatorens høyspentside viste at det ikke var noen tydelige fordeler ved å benytte denne strategien. Stabiliteten ble ikke forbedret, og variasjonene i spenning og reaktiv effekt forble omtrent like store sammenlignet med tilfellet der målingene ble tatt fra generatorenes terminaler. Det ble også funnet at det ikke kunne være en netto reaktiv kompensasjon på terminalene til parallelle generatorer, uavhengig av hvilket

målepunkt som ble benyttet. Følgelig kan ikke kompensasjon benyttes for å oppnå en konstant spenning på transformatorens høyspentside når flere generatorer er tilkoblet en felles transformator. Det må derfor være en netto statikk på generatorterminalene i slike tilfeller, som nevnt ovenfor.

Undersøkelsene av spenningsregulatorens innstilling for reaktiv statikk og kompensasjon for en generator som opererer alene, viste at generatorene muligens kunne være i stand til å bidra til å forbedre den samlede spenningsreguleringen i systemet. For en enkelt generator kan reaktiv kompensasjon benyttes, og følgelig kan spenningen på transformatorens høyspentside bli mer konstant, avhengig av nettet generatoren er tilkoblet.

Simuleringene som undersøkte spenningsregulatorenes innstillinger for ulike spenningsintervaller, viste at den reaktive statikken burde justeres etter gunstige spenningsintervaller for å forbedre reguleringen. I dagens system er statikken på generatorene i Hove og Refsdal på henholdsvis 5% og 10%. Men når reguleringsprosedyrene med å justere settpunktene for reaktiv effekt blir tatt i betraktning, viser det seg at den resulterende statikken på høyspentsiden er på henholdsvis 33% og 38% i Hove og Refsdal. Dette er en stor statikk, og generatorene vil derfor ikke gi noe bidrag til reguleringen i særlig grad. For å oppnå en bedre innstilling av spenningsregulatorene, må kraftprodusenten bestemme hvilket spenningsintervall den reaktive statikken skal tilpasses. Dersom kraftprodusenten ønsker å unngå å endre settpunktet for spenning eller reaktiv effekt selv for store spenningsintervaller, må statikken være stor. Dersom et mindre spenningsintervall blir lagt til grunn, vil statikken derimot kunne reduseres. Som nevnt ovenfor vil den resulterende statikken på høyspentsiden være avhengig av både statikken på generatorene og spenningsfallet over transformatoren.

Det bør også nevnes at Statnetts krav i forhold til spenningsregulering og forsyning av reaktiv effekt kan være vanskelige å oppfylle for kraftprodusentene, for tilfeller der flere generatorer er tilknyttet en felles transformator. Simuleringene og de analytiske evalueringene indikerte at den resulterende statikken på høyspentsiden, på grunn av transformatorens reaktans, var større enn hva disse kravene tilsier. For å imøtekomme Statnetts krav må kraftprodusentene, som opererer parallelle generatorer, muligens benytte reguleringsmetoder som justerer spenningsregulatorens settpunkter, for eksempel ved hjelp av en sekundær reguleringsløyfe. Likevel burde Statnetts krav i forhold til regulering av spenning og reaktiv effekt, samt samarbeidet mellom Statnett og kraftprodusentene, studeres videre, for å kunne tilnærme seg utfordringene relatert til den overordnede reguleringen av spenning og reaktiv effekt i kraftsystemet.

Abbreviations

AC	Alternating Current
AVR	Automatic Voltage Regulator
B	Susceptance
DC	Direct Current
EMF	Electromotive Force
FACTS	Flexible AC Transmission Systems
G	Conductance
GOV	Governor
OEL	Overexcitation Limiter
P	Active Power
PSS	Power System Stabilizer
R	Resistance
S	Apparent Power
STATCOM	Static Synchronous Compensator
SVC	Static VAR Compensator
SVG	Static VAR Generator
TSO	Transmission System Operator
UEL	Underexcitation Limiter
UPFC	Unified Power Flow Controller
Q	Reactive Power
X	Reactance

Contents

Preface	I
Abstract	III
Sammendrag	V
Abbreviations	VII
Contents	IX
List of Figures	XIII
List of Tables	XVIII
1 Introduction	1
1.1 Background and Objective	1
1.2 Scope and Limitations of the Work	3
1.3 Outline of the Report	4
1.4 Confidential Information	4
2 Power System Stability	5
2.1 Voltage and Reactive Power Control	6
2.1.1 Flow of Reactive Power	7
2.1.2 The Synchronous Generator	8
2.1.3 The Exciter	10
2.1.4 Reactive Power Control	11
2.1.5 Excitation Limits	12
2.1.6 The Automatic Voltage Regulator	15
2.1.7 The AVR's Droop Function	16
2.1.8 Generators in Parallel	20
2.1.9 General Ways to Control Voltage and Reactive Power	21
2.1.10 Introduction to Statnett's Demands Regarding Voltage and Reactive Power Control	23
2.1.11 Introduction to the Voltage Drop Across a Power Transformer	24
2.1.12 Voltage Control by Measuring on the Transformer's Secondary Side	25
2.2 Frequency and Active Power Control	25
2.2.1 Active Power Control	25
2.2.2 The Governor	26

2.2.3	The Speed-droop	27
3	System Description	28
4	Voltage Control in the System to Be Studied	31
5	The Simulation Programme DIgSILENT PowerFactory	37
6	Modelling of the System	38
6.1	Simplifications in the Models	38
6.2	AVR, Droop and Compensation	39
6.3	Generator and Transformer Data	42
6.4	Other Information	43
7	Simulations	45
7.1	Investigating the Manner of Operation for the Current Control Strategy	46
7.2	Investigating Droop and Compensation, When Considering Voltage Drop Across a Transformer	47
7.3	Investigating the Effect of Droop and Compensation, When Taking the Measurements Given to the AVR from the Generators' Terminals	48
7.4	Investigating the Effect of Droop and Compensation, When Taking the Measurements Given to the AVR from the Transformer's Secondary Side	49
7.5	Trying to Tune the Droop Settings for Various Voltage Ranges . . .	50
8	Results	51
8.1	Investigating the Manner of Operation for the Current Control Strategy	51
8.1.1	Adjusting the Voltage Set Point for the Generators at the Exact Same Time as the System Voltage Changes	51
8.1.2	Adjusting the Voltage Set Point for the Generators After the System Voltage Was Changed	54
8.2	Investigating Droop and Compensation, When Considering Voltage Drop Across a Transformer	56
8.2.1	Investigating Voltage Variations with Respect to Active and Reactive Power Supply	56
8.2.2	Changing the System Voltage and Loading When There Is No Droop or Compensation Applied	58
8.2.3	Changing the System Voltage and Loading When Compensation Is Applied	59
8.2.4	Changing the System Voltage and Loading When Droop Is Applied	60

8.3	Investigating the Effect of Droop and Compensation, When Taking the Measurements Given to the AVR from the Generators' Terminals	60
8.3.1	Changing the System Voltage When Compensation Is Studied for One Generator in Hove Power Station	61
8.3.2	Changing the System Voltage When No Droop Is Applied	65
8.3.3	Changing the System Voltage When Droop Is Applied	67
8.4	Investigating the Effect of Droop and Compensation, When Taking the Measurements Given to the AVR from the Transformer's Secondary Side	70
8.4.1	Changing the System Voltage When Compensation Is Studied for One Generator in Hove Power Station	70
8.4.2	Changing the System Voltage When No Droop Is Applied	76
8.4.3	Changing the System Voltage When Droop Is Applied	77
8.5	Trying to Tune the Droop Settings for Various Voltage Ranges	83
8.5.1	Tuning of the Applied Droop in a System Utilizing Primary Side Measurements	83
8.5.2	Tuning of the Applied Droop in a System Utilizing Primary Side Measurements, When the Continuous and Temporary Voltage Limits in FIKS Are Considered	84
9	Discussion of the Results	87
9.1	Investigating the Manner of Operation for the Current Control Strategy	87
9.2	Investigating Droop and Compensation, When Considering Voltage Drop Across a Transformer	88
9.2.1	Investigating Voltage Variations with Respect to Active and Reactive Power Supply	88
9.2.2	Studying Droop and Compensation for a Single Generator	89
9.3	Investigating the Effect of Droop and Compensation, When Taking the Measurements Given to the AVR from the Generators' Terminals	90
9.3.1	Changing the System Voltage When Compensation Is Studied for One Generator in Hove Power Station	90
9.3.2	Investigating the Effect of Droop and Compensation on Generators Operating in Parallel	92
9.4	Investigating the Effect of Droop and Compensation, When Taking the Measurements Given to the AVR from the Transformer's Secondary Side	93
9.4.1	Changing the System Voltage When Compensation Is Studied for One Generator in Hove Power Station	93
9.4.2	Investigating the Effect of Droop and Compensation on Generators Operating in Parallel	95
9.5	Trying to Tune the Droop Settings for Various Voltage Ranges	97

9.5.1	Tuning of the Applied Droop in a System Utilizing Primary Side Measurements	97
9.5.2	Tuning of the Applied Droop in a System Utilizing Primary Side Measurements When the Continuous and Temporary Voltage Limits in FIKS Are Considered	97
10	Discussion of Other Topics	99
10.1	Other Suggestions for Possible Solutions to Improve the Regulation	99
10.2	Evaluation of Different Control Strategies	100
10.3	Evaluation of Statnett's Requirements Regarding Voltage and Reactive Power Control	101
11	Conclusion	102
12	Suggestions for Further Work	104
	References	105
A	Appendix	107
A.1	Modelling of the System	107
A.1.1	AVR, Droop and Compensation	107
A.2	Simulations, Results and Discussion	109
A.2.1	Investigating Voltage Variations with Respect to Active and Reactive Power Supply for Refsdal Power Station	109
A.2.2	Changing the System Voltage When Compensation Is Studied for One Generator in Refsdal Power Station, and Primary Side Measurements Are Utilized	112
A.2.3	Changing the System Voltage When Compensation Is Studied for One Generator in Refsdal Power Station, and Secondary Side Measurements Are Utilized	115

List of Figures

1	Classification of power system stability	5
2	Phasor diagram of a synchronous generator at lagging power factor	9
3	Phasor diagram of a synchronous generator at leading power factor	9
4	Excitation system for a synchronous generator	11
5	VQ-curve for a synchronous generator with constant field current .	12
6	Generator phasor diagram for a lagging power factor	14
7	Generator phasor diagram with power units for a lagging power factor	14
8	Reactive capability curve	15
9	Sketch of a simple excitation system including droop	18
10	Droop characteristic for voltage and reactive power	19
11	Droop characteristic for voltage and reactive power when changing U_{setp}	20
12	Equivalent circuit model of a power transformer	24
13	Power vs. frequency curve for a synchronous generator	26
14	Main components in the HPC 185 AVR	29
15	VQ-characteristics for the secondary side in Hove and Refsdal power stations, when considering the current regulation scheme	33
16	Illustrating how the set points must be changed, when the droop on the transformer's secondary side is less than the droop in the regulation scheme	33
17	Illustrating how the set points must be changed, when the droop on the transformer's secondary side is larger than the droop in the regulation scheme	34
18	VQ-characteristics for the secondary side in Hove and Refsdal power stations, when considering the continuous voltage limits in FIKS . .	36
19	Excitation system of type AC8B used in the two power stations . .	40
20	The loop utilized for applying droop and compensation, when the measurements are taken from the transformer's primary side	40
21	The loop utilized for applying droop and compensation, when the measurements are taken from the transformer's secondary side . . .	42
22	System with two power stations, each having two generators con- nected to a common transformer	45
23	System with one generator connected to the grid	46
24	Voltage responses for the system when the voltage set points for the generators were changed at the exact same time as the system voltage changed	52

25	Responses in reactive power for the system when the voltage set points for the generators were changed at the exact same time as the system voltage changed	52
26	VQ-characteristics for the power stations when the voltage set points for the generators were changed at the exact same time as the system voltage changed	53
27	VQ-characteristics for the power stations when the voltage set points for the generators were changed at the exact same time as the system voltage changed, and droop was applied	54
28	Voltage responses for the system when the voltage set points for the generators were changed after the system voltage was changed . . .	55
29	Responses in reactive power for the system when the voltage set points for the generators were changed after the system voltage was changed	55
30	Voltage drop across the transformer in Hove when the generators are not delivering any active power	57
31	Voltage drop across the transformer in Hove when the generators are delivering 50% active power	57
32	Voltage drop across the transformer in Hove when the generators are delivering 100% active power	58
33	VQ-characteristic when no droop or compensation is applied	59
34	VQ-characteristic when compensation is applied	59
35	VQ-characteristic when droop is applied	60
36	Voltage responses for a weak grid when primary side measurements are utilized, and only one generator in Hove is considered	62
37	Response in reactive power for a weak grid when primary side measurements are utilized, and only one generator in Hove is considered	62
38	VQ-characteristic for a generator in Hove when a weaker grid is considered, and the measurements are taken from the transformer's primary side	63
39	Voltage responses for a strong grid when primary side measurements are utilized, and only one generator in Hove is considered	64
40	Response in reactive power for a strong grid when primary side measurements are utilized, and only one generator in Hove is considered	64
41	VQ-characteristic for a generator in Hove when a strong grid is considered, and the measurements are taken from the transformer's primary side	65
42	VQ-characteristics when the measurements are taken from the transformer's primary side, and no droop or compensation is applied . .	66

43	VQ-characteristics when the measurements are taken from the transformer's primary side, and compensation is applied	66
44	Unstable responses in reactive power when no droop is applied, and unideal operating conditions are considered	67
45	VQ-characteristics for the power stations when the measurements are taken from the transformer's primary side, and droop is applied . .	68
46	Stable voltage responses when droop is applied, and unideal operating conditions are considered	69
47	Stable responses in reactive power when droop is applied, and unideal operating conditions are considered	69
48	Voltage responses for a weak grid when secondary side measurements are utilized, and only one generator in Hove is considered	71
49	Response in reactive power for a weak grid when secondary side measurements are utilized, and only one generator in Hove is considered	71
50	VQ-characteristic for a generator in Hove when a weaker grid is considered, and the measurements are taken from the transformer's secondary side	72
51	Voltage responses for a strong grid when secondary side measurements are utilized, and only one generator in Hove is considered . .	73
52	Response in reactive power for a strong grid when secondary side measurements are utilized, and only one generator in Hove is considered	73
53	VQ-characteristic for a generator in Hove when a strong grid is considered, and the measurements are taken from the transformer's secondary side	74
54	Unstable voltage responses when a large compensation is applied, and the measurements are taken from the transformer's secondary side	75
55	Unstable response in reactive power when a large compensation is applied, and the measurements are taken from the transformer's secondary side	75
56	Unstable voltage responses when no droop or compensation is applied, and the measurements are taken from the transformer's secondary side	76
57	Unstable responses in reactive power when no droop or compensation is applied, and the measurements are taken from the transformer's secondary side	77
58	Voltage responses when droop is applied, and the measurements are taken from the transformer's secondary side	78
59	Responses in reactive power when droop is applied, and the measurements are taken from the transformer's secondary side	78

60	VQ-characteristics for the power stations when the measurements are taken from the transformer's secondary side, and droop is applied at the generators	79
61	Voltage responses when droop is applied, and the measurements are taken from the transformer's secondary side	80
62	Responses in reactive power when droop is applied, and the measurements are taken from the transformer's secondary side	80
63	VQ-characteristics for the power stations when the measurements are taken from the transformer's secondary side, and droop is applied	81
64	Unstable voltage responses when droop is applied, and unideal operating conditions are considered	82
65	Unstable responses in reactive power when droop is applied, and unideal operating conditions are considered	82
66	Voltage responses for the system when the measurements are taken from the transformer's primary side, and a voltage range from 0.975 p.u. to 1.025 p.u. is considered	83
67	Responses in reactive power for the system the measurements are taken from the transformer's primary side, and a voltage range from 0.975 p.u. to 1.025 p.u. is considered	84
68	VQ-characteristics for the power stations, when trying to tune the droop considering the continuous voltage limit	85
69	VQ-characteristics for the power stations, when trying to tune the droop considering the 15 minute temporary voltage limit	86
70	Droop frame	107
71	The loop utilized for applying droop and compensation, when the measurements are taken from the transformer's primary side	107
72	The loop utilized for applying droop and compensation, when the measurements are taken from the transformer's secondary side	108
73	Voltage drop across the transformer in Refsdal when the generators are not delivering any active power	110
74	Voltage drop across the transformer in Refsdal when the generators are delivering 50% active power	110
75	Voltage drop across the transformer in Refsdal when the generators are delivering 100% active power	111
76	VQ-characteristic for a generator in Refsdal when a weaker grid is considered, and the measurements are taken from the transformer's primary side	113
77	VQ-characteristic for a generator in Refsdal when a strong grid is considered, and the measurements are taken from the transformer's primary side	114

78	VQ-characteristic for a generator in Refsdal when a weaker grid is considered, and the measurements are taken from the transformer's secondary side	116
79	VQ-characteristic for a generator in Refsdal when a strong grid is considered, and the measurements are taken from the transformer's secondary side	117

List of Tables

1	Characteristic data for the generators in Hove power station	28
2	Characteristic data for the generators in Refsdal power station . . .	28
3	Characteristic data for the transformer in Hove power station . . .	28
4	Characteristic data for the transformer in Refsdal power station . .	29
5	Reactive power generation in Hove, when considering Statnett's re- quirements for voltage control	35
6	Reactive power generation in Refsdal, when considering Statnett's requirements for voltage control	35
7	Active and reactive power generation in Hove, when considering Stat- nett's requirements for voltage control	43
8	Active and reactive power generation in Refsdal, when considering Statnett's requirements for voltage control	43
9	Q and V for the power stations when the voltage set points for the generators were changed at the exact same time as the system voltage changed	53
10	Q and V for the power stations when the voltage set points for the generators were changed at the exact same time as the system voltage changed, and droop was applied	53
11	Q and V for the power stations when the voltage set points for the generators were changed after the system voltage was changed . . .	56
12	Q and V for a generator in Hove connected to a weaker grid, when the measurements are taken from the transformer's primary side . .	61
13	Q and V for a generator in Hove connected to a weaker grid when a smaller compensation is applied, and the measurements are taken from the transformer's primary side	63
14	Q and V for a generator in Hove connected to a strong grid, when the measurements are taken from the transformer's primary side . .	65
15	Q and V for the power stations when the measurements are taken from the transformer's primary side, and droop is applied	68
16	Q and V for a generator in Hove connected to a weaker grid, when the measurements are taken from the transformer's secondary side .	72
17	Q and V for a generator in Hove connected to a strong grid, when the measurements are taken from the transformer's secondary side .	74
18	Q and V for the power stations when the measurements are taken from the transformer's secondary side, and droop is applied at the generators	79
19	Q and V for the power stations when the measurements are taken from the transformer's secondary side, and droop is applied	81

20	Q and V for the power stations, when trying to tune the droop considering the continuous voltage limit	85
21	Q and V for the power stations, when trying to tune the droop considering the 15 minute temporary voltage limit	86
22	Q and V for a generator in Refsdal connected to a weaker grid, when the measurements are taken from the transformer's primary side . .	112
23	Q and V for a generator in Refsdal connected to a strong grid, when the measurements are taken from the transformer's primary side . .	113
24	Q and V for a generator in Refsdal connected to a weaker grid, when the measurements are taken from the transformer's secondary side .	115
25	Q and V for a generator in Refsdal connected to a strong grid, when the measurements are taken from the transformer's secondary side .	116

1 Introduction

1.1 Background and Objective

A solid, stable and well functioning power system is of great significance, and many factors and requirements must be taken into consideration in order to achieve this. A fundamental aspect is the cooperation between grid operators and power producers. This cooperation must be well defined and efficient in order to serve the expectations regarding reliability and security. The transmission system operator (TSO) is responsible for coordination of power production and transmission, and must ensure that the instant power balance is maintained. Also the TSO is responsible for frequency regulation and for ensuring that all power plants, connected to the transmission and sub-transmission grid, have the necessary functionalities to remain an efficient and satisfactory quality of supply [1]. The main objective is to meet the demands from industry and other customers, regarding quality and reliability, and at the same time maintain security. Besides the power supply itself, the voltage levels must also be satisfactory. In order to obtain desired voltage levels the production must be coordinated, and hence some demands given by the TSO must be fulfilled by the power producers. I.e. the power producers should contribute to control of voltage and reactive power flow in the grid. Thus, the ability to control generating units is important, and a well functioning control system is therefore needed. Typically, the control system of a generating unit includes turbine regulator or governor (GOV), automatic voltage regulator (AVR) and exciter, as well as power system stabilizer (PSS).

In this thesis voltage control and provision of reactive power reserves will be studied for multiple generators connected to a common transformer. The system to be considered consists of two power stations in Vik in Sogn, Hove and Refsdal, which are operated by Statkraft. Each of the power stations has two generators that are connected to the grid through a common transformer. Operating paralleled generators can be quite challenging, and in order to obtain stable generator operation, situations with opposing generators, should be avoided. This means that there should be a coordinated distribution of reactive power, which is normally obtained by introducing a reactive droop functionality in the AVR. It is also important to consider the voltage drop across the transformer, as this will affect the voltage control.

In order to have a good control of voltage and reactive power, it is important to tune the droop properly. In the specialization project *Voltage Control and Sharing of Reactive Power*, from autumn 2015, it was found that reactive droop was needed

when operating paralleled generators. This thesis will investigate this further, and study the effect of utilizing measurements from the transformer's grid side as input to the AVR, instead of taking them from the generators' terminals. The effect of applying reactive compensation will also be studied, and within this topic the focus will mainly be on one generator operating alone and on the operation of paralleled generators when utilizing measurements from the transformer's grid side. By compensation it is in this context meant negative reactive droop, such that the voltage at the generator's terminal increases with increasing generation of reactive power. The reason for why compensation is to be studied, is that this might improve the voltage stability at the transformer's grid side, compensating for the voltage drop across the transformer.

As mentioned above, operation of paralleled generators can often make it more difficult to obtain a good regulation, and the control can consequently become more complicated. In the system to be studied the voltage control is quite different from what is considered as a typical control strategy. The voltage control of the generators is today obtained by adjusting the generation or absorption of reactive power, by manually changing the set point for reactive power. This set point is determined by the system voltage. The power producer, in this case Statkraft, wants to be able to control the voltage without having to manually give a set point for reactive power, as this practice is somewhat cumbersome. I.e., it is desirable to make the control easier.

In the control system utilized in the two power stations today, the change in reactive set point is based on measurements of voltage and current from the transformer's generator side. It is common to take the measurements from the generator's terminals, and most control systems therefore utilize this strategy. This will though not necessarily be satisfactory. In some cases it might be advantageous to move the measurements to the transformer's grid side, or secondary side. By taking measurements of voltage and current from the secondary side the generators' AVRs may possibly be able to respond to changes in the grid in a better way. The control may also become more precise. This thesis will therefore investigate whether moving the measurements will lead to a better regulation or not.

This thesis shall analyze voltage control and reactive power in an attempt to come up with suggestions to how voltage control of paralleled generators can be done. The work done in the specialization project *Voltage Control and Sharing of Reactive Power* will be continued in this thesis, and hence a further analysis of different aspects will be done. The thesis shall investigate how the AVR's tuning of droop and compensation will affect a power system with generators operating in parallel, and how utilizing different measurements will affect the regulation. The voltage

drop across the transformers will also be considered. In addition, the principle of the control strategy utilized today will be discussed and tested, and the TSO's requirements regarding voltage and reactive power control will be considered. To decide what contribution the generators should give, in order to maintain a desired voltage level, is another challenge. The contribution should be based on the TSO's demands, but the grid and the generators capacities must also be taken into consideration. The objective of the thesis is to come up with suggestions to how a coordinated, well functioning regulation can be achieved.

1.2 Scope and Limitations of the Work

The analysis of voltage and reactive power control of the paralleled generators will be performed by using the software DIgSILENT PowerFactory. As for the specialization project from autumn 2015, the simulations will be based on a simplified model of the physical system in Vik. Several simulations will be done, and, as mentioned above, the impact of voltage drop across a transformer, droop, compensation and different measuring points will be investigated. The current control strategy and the TSO's requirements will also be discussed.

A limitation of the work is related to voltage and reactive power control. When the effect of taking the measurements given to the AVR from the transformer's secondary side should be investigated, the voltage at the grid side was estimated, not measured. The reason for why this approach was chosen was the practical implementation in PowerFactory, as it turned out that actually taking the measurements from the grid side would be very difficult. However, testing of the system showed that this simplification was working sufficiently. The estimation will be further commented in chapter 6. In the simulations studying the manner of operation for the current control system, it was decided to change the generators' voltage set point. This was done because it would have been difficult to change the reactive set point in PowerFactory. As a change in voltage set point will have the same effect as changing the reactive set point, according to the AVR's VQ-characteristic, it was decided that this was an acceptable simplification.

Another limitation of the work is related to the technical aspects discussed in this thesis. Measuring points, tuning of droop, and compensation were studied, but additional loops providing secondary control, etc., were not studied. This would have been interesting to investigate, but unfortunately there was not enough time to study secondary control loops when this possibility was discovered. Secondary control and other possible solutions will be further commented in chapter 10.

1.3 Outline of the Report

The first part of this report considers some fundamental theory regarding power system stability, with respect to voltage control and reactive power. There will be paid attention to the synchronous generator's ability to both supply and absorb reactive power. In addition the AVR's droop function will be explained, and possible effects of utilizing different measuring points will be presented. Further, the considered system and today's control strategy will be described, and possible strategies to improve the control will be discussed. The simplified models used for the simulations will also be presented. Later in the report the different simulations that have been done will be presented, and the results will be discussed. Other possible solutions, that were not tested in this thesis, will also be commented, and the TSO's requirements regarding voltage and reactive power control will be discussed. A conclusion of the work, concerning tuning of the AVRs, utilization of different measurements, and suggestions for control strategies, will be given towards the end of the report. Lastly some suggestions for further work will be given.

1.4 Confidential Information

Some data regarding the actual system are left out of this report. This is because some of this information is considered as sensitive according to §6.2 in the Norwegian regulation "Forskrift om forebyggende sikkerhet og beredskap i energiforsyningen (beredskapsforskriften)". An appendix with the necessary information will be given to the evaluators in addition to this report.

2 Power System Stability

The theory presented in this chapter is partly the same as for the specialization project *Voltage Control and Sharing of Reactive Power* from autumn 2015 [2, p. 4-22]. Some of the sections are also new, and some are rewritten.

The supply of electricity has become more important to the society throughout the years, and today electricity is considered as crucial for the everyday life by very many. In order to have a secure and reliable supply of electric power, a well functioning power system is needed. For the power system to be well functioning, providing electricity according to our expectations, power system stability is important. Power system stability can be explained as "the ability to regain an equilibrium state after being subjected to a physical disturbance" [3, p. 9]. There are many factors affecting the stability of a power system, such as the system's operating state and possible disturbances or contingencies. Power system stability comprises rotor angle stability, frequency stability and voltage stability, and is mainly affected by electromechanical phenomena [3]. Figure 1 below shows how power system stability can be classified.

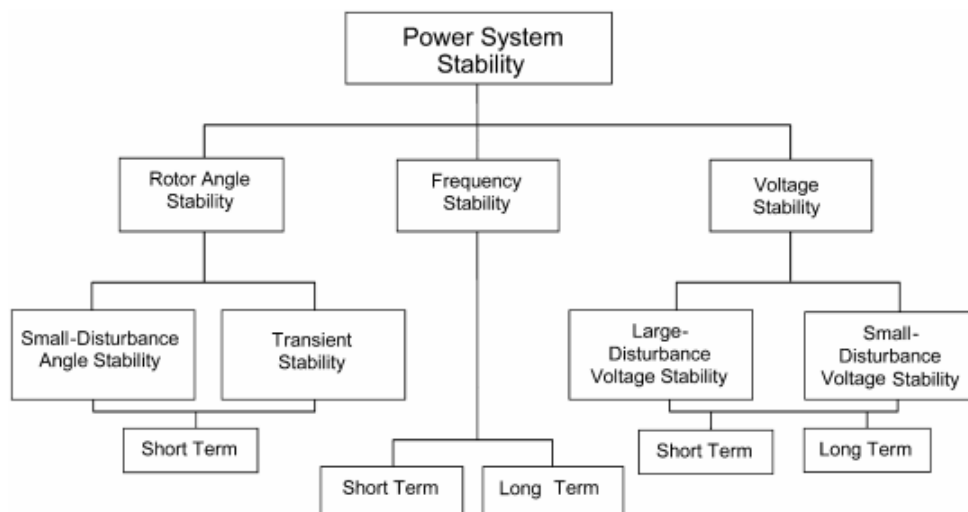

Figure 1: Classification of power system stability [4, p. 1390]

Stability can also be considered for one generator only. It is then common to distinguish between stationary stability and transient stability. A generator's stationary

stability describes its ability to handle changes in the grid caused by ordinary changes in load flow etc. [1]. The Norwegian TSO demands that the generators at all times are able to handle such changes, preventing power swings from occurring [1]. Transient generator stability is, on the other hand, defined as the generator's ability to stabilize and maintain synchronism after being subjected to a larger disturbance [1]. Power system security is a broader term than power system stability, and it can be described as the ability of a power system to survive contingencies. In order to be secure, the power system should also be able to maintain power delivery to the customers [3]. These terms will though not be further discussed in this report.

There are several ways to control power systems, and hence secure stable operation. Various generator controls should contribute to sustain a desired voltage level, and hence adjust reactive power production. Frequency controls should, on the other hand, contribute to maintain the required rotor speed in order to sustain a desired electric frequency. Also, the frequency controls ought to control the generation of active power [5]. The control principles for a power system can be divided into three groups: primary control, secondary control and tertiary control. Primary control is often automatic and responds fast, and it can comprise e.g. voltage, speed and frequency. Secondary control comprises change of reference values for e.g. voltage and power, and is consequently slower compared to primary control. Tertiary control includes restoration of reserves and is carried out manually. Hence, it is a slow form of control [5].

2.1 Voltage and Reactive Power Control

In order to sustain a desired voltage level in the grid, it is important that the generators are able to cover the total load demand within different regions, and operate at a certain voltage level. Another fundamental issue is the systems ability to handle reactive power (Q). The voltage and reactive power control can be divided into three main categories: primary, secondary and tertiary. Primary control is fast and is utilized in e.g. generators and AVRs. The secondary voltage and reactive power control deals with reference values, and is slower than the primary. Tertiary control is related to economy and optimization of the system [6].

2.1.1 Flow of Reactive Power

It is known that the voltage magnitude at a bus increases when reactive power is injected at the bus. This can be explained from the power flow equations. For each bus i the apparent power (S) can be expressed in terms of active power (P) and reactive power, or in terms of voltage (V) and current (I), as shown in the following equation.

$$S_i = P_i + jQ_i = V_i \cdot I_i^* \quad (1)$$

Considering a simple two bus system, it can easily be shown that the flow of active power is dependent on the voltage angle, whereas the reactive power flow is dependent on the voltage magnitude.

The current in a line connecting two buses can be expressed as

$$I = \frac{|V_1| \angle \delta_1 - |V_2| \angle \delta_2}{|Z| \angle \rho} \quad (2)$$

By inserting the expression for the current into equation 1 the expressions for apparent power at the two buses can be found.

$$S_1 = |V_1| \angle \delta_1 \cdot \left(\frac{|V_1| \angle \delta_1 - |V_2| \angle \delta_2}{|Z| \angle \rho} \right)^* \quad (3)$$

$$S_2 = |V_2| \angle \delta_2 \cdot \left(\frac{|V_1| \angle \delta_1 - |V_2| \angle \delta_2}{|Z| \angle \rho} \right)^* \quad (4)$$

If it is assumed that the resistance in the line impedance $Z = R + jX$ can be neglected, the impedance becomes $Z = jX$. When applying Euler's formula, $e^{j\theta} = \cos \theta + j \sin \theta$, the expressions for active and reactive power can be obtained. The equations for both buses are given below.

$$P_1 = \frac{|V_1| \cdot |V_2|}{|X|} \cdot \sin \delta_{12} \quad (5)$$

$$Q_1 = \frac{|V_1|}{|X|} \cdot (|V_1| - |V_2| \cos \delta_{12}) \quad (6)$$

$$P_2 = \frac{|V_1| \cdot |V_2|}{|X|} \cdot \sin \delta_{12} \quad (7)$$

$$Q_2 = \frac{|V_2|}{|X|} \cdot (|V_1| \cos \delta_{12} - |V_2|) \quad (8)$$

The angle δ_{12} corresponds to $\delta_1 - \delta_2$. To show that P is dependent on δ_{12} and Q is dependent on $|V|$, it is assumed that $\delta_{12} \rightarrow 0$. This is true for normal operating

conditions. The following approximations are then obtained: $\sin \delta_{12} \rightarrow \delta_{12}$ and $\cos \delta_{12} \rightarrow 1$. The equations then simplify to the following:

$$P_1 = \frac{|V_1| \cdot |V_2| \cdot \delta_{12}}{|X|} \quad (9)$$

$$Q_1 = \frac{|V_1|}{|X|} \cdot (|V_1| - |V_2|) \quad (10)$$

$$P_2 = \frac{|V_1| \cdot |V_2| \cdot \delta_{12}}{|X|} \quad (11)$$

$$Q_2 = \frac{|V_2|}{|X|} \cdot (|V_1| - |V_2|) \quad (12)$$

It can now be observed that the flow of active power is dependent on the voltage angle, as the active power will flow from the bus with the largest voltage angle towards the bus with the smallest angle. The reactive power is, on the other hand, dependent on the voltage magnitude, as the reactive power will flow from the bus with the highest voltage magnitude towards the bus with the lowest. To avoid unwanted flow of reactive power it is therefore necessary to control the voltage magnitudes at the buses. If voltage magnitudes are not controlled, circulation of reactive power can occur. This would increase the losses and reduce the power system's ability to generate and transfer real power.

2.1.2 The Synchronous Generator

Most of the electric power generation in the world is carried out using synchronous generators [7]. For this type of generator, the fields, currents and voltages are to a large degree interdependent. This implies that there are really only two ways to control the generator's behaviour: either by regulating the rotational frequency or by regulating the terminal voltage [8]. The rotational frequency is related to the generation of real power, whereas the voltage at the terminals is related to the generation of reactive power [8].

As mentioned, the synchronous generators are very important considering power generation. In addition, they play an important role in distributing reactive power in the grid. This is due to their ability to both deliver and absorb reactive power, depending on the state of the grid. The generator's ability to generate and absorb reactive power is related to the machine's over- and underexcitation limits [9]. These limitations will be commented later, in section 2.1.5.

For a synchronous generator the internal generated voltage, E_A , is always leading the phase voltage, V_ϕ , such that active power is delivered from the generator to the grid. The generation of reactive power is on the other hand dependent on whether the armature current, I_A , leads or lags V_ϕ .

As figure 2 shows, the synchronous generator is overexcited when $E_A \cos\delta > V_\phi$. Reactive power will then flow from the armature to the terminals, and the generator will supply reactive power. As loads are often inductive, this is the most common state of generator operation [8]. For the underexcited case when $|E_A| \cos\delta < V_\phi$, the generator will consume reactive power. Reactive power will then flow from the generator terminals towards the armature [10]. A phasor diagram of a synchronous generator at leading power factor is shown in figure 3.

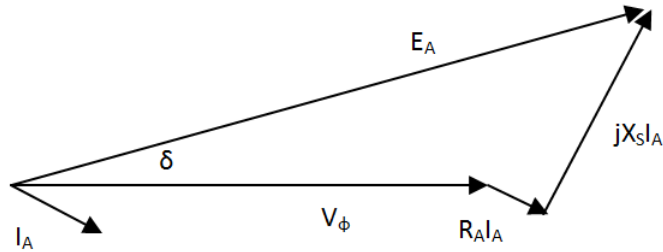

Figure 2: Phasor diagram of a synchronous generator at lagging power factor

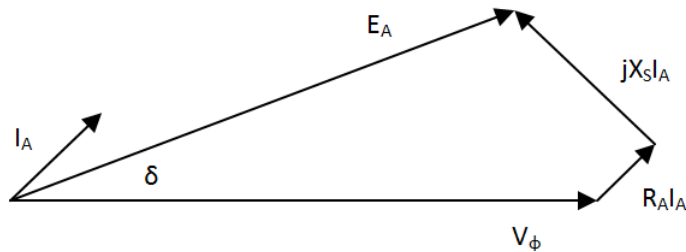

Figure 3: Phasor diagram of a synchronous generator at leading power factor

If the synchronous generators were not able to help control the flow of reactive power, there would have been a larger need for FACTS (flexible AC transmission systems) devices or static VAR compensators (SVCs) to take care of this distribution. These devices will be further commented in section 2.1.9.

2.1.3 The Exciter

The exciter should provide a magnetization current (DC current) to the generator's field winding such that a rotating magnetic flux is obtained. This flux induces an electromotive force (emf) in each of the three phases in the stator armature winding, which will cause AC currents flowing out in the grid [3].

The voltage at a generator's terminals is mainly controlled by the exciter and the AVR. This is because the amount of magnetization current applied to the field winding will influence the voltage at the generator terminals. Less magnetization current implies a lower terminal voltage, whereas a higher magnetization current implies a voltage rise at the terminals. The magnitude of the magnetization current is determined by the AVR. The AVR receives measurements from the generator terminals, and based on these it decides how the voltage should be adjusted in order to maintain a desired voltage level. The measurements can also be done further away from the generator. This will be discussed later in this report.

A complete excitation system does not only include the exciter itself. It typically consists of an AVR combined with some compensation, exciter, PSS and various limiters [11]. A block diagram of an excitation system is shown in figure 4 below.

There are mainly three types of excitation systems [11]:

- DC excitation systems
- AC excitation systems
- Static excitation systems

These different technical solutions will not be further discussed in this report.

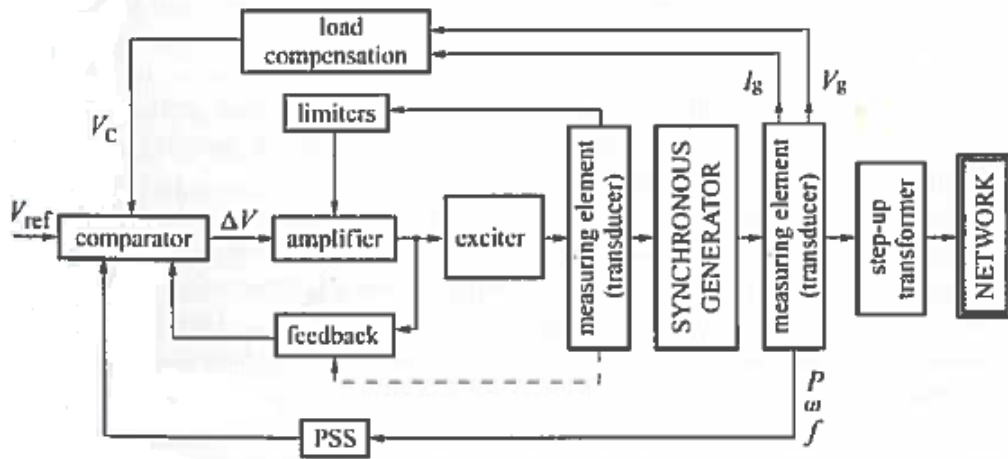

Figure 4: Excitation system for a synchronous generator [3, p. 23]

2.1.4 Reactive Power Control

As already mentioned, the synchronous generator is important in order to control the flow of reactive power. Section 2.1.3 explained how the current injected in the field windings determined the voltage at the generator's terminals. The terminal voltage is also affected differently by inductive and capacitive loads, as will be described below.

If the generator is to supply an inductive load in the system, with lagging power factor demanding reactive power, the armature current will lag the emf in the stator windings. The stator field will then oppose the rotor field. The angle between the rotor and stator field will hence be larger than 90° , due to the contribution from the inductive load. If the load was purely resistive, the stator field would only consist of a component perpendicular to the rotor field. By having a inductive load there will be a parallel and opposing component to the rotor field as well. This will diminish the rotor field. Consequently the voltage at the generator's terminals is reduced, and the generator produces reactive power [8]. This is in accordance with the operating state shown in figure 2.

A capacitive load, with leading power factor supplying reactive power, will cause the armature current to lead the emf in the stator windings. The stator field will then act to strengthen the rotor field, due to an angle between the rotor and stator field of less than 90° . The capacitive load will consequently increase the voltage at the generator terminals, and the generator absorbs reactive power [8]. This coincide with the operating state shown in figure 3.

The resulting curve for the relationship between voltage and reactive power for a synchronous generator is given in figure 5. The figure illustrates how a larger supply of reactive power from the generator decreases the terminal voltage. If the generator is absorbing reactive power, the voltage would, on the other hand, increase compared to the no-load terminal voltage. The field current remains constant for the case in the figure below.

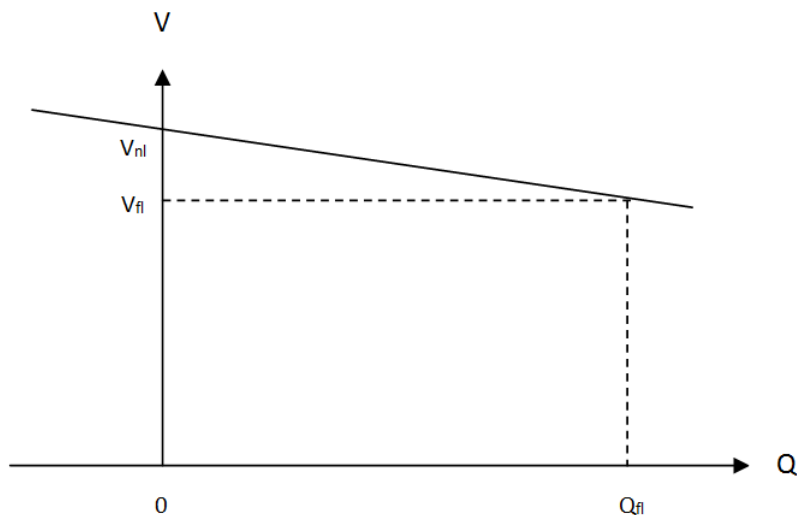

Figure 5: VQ-curve for a synchronous generator with constant field current

If a synchronous generator is exposed to a voltage rise, the AVR and exciter will decrease the field current in the field windings. As a consequence, the magnetic field and the terminal voltage are decreased. The generator will then deliver more reactive power. In this way, the AVR and synchronous generator will contribute to keep the voltage in the system at a desired level. On the other hand, if a generator experiences a voltage drop, the AVR and exciter will increase the field current in order to maintain a desired voltage at the terminals. The generator will then reduce its supply of reactive power. Again, the synchronous generator and the AVR would contribute to control the voltage.

2.1.5 Excitation Limits

The power limitations of electric machines are in general determined by two factors: mechanical torque on the rotor and heating of the windings [10]. The critical factor is the heat generation. High currents and large increase in temperatures can e.g. weaken the insulating material in the windings, which can further lead to internal

faults and short circuits [8]. The thermal limits for a synchronous generator can be divided into armature thermal limit, field current limit and stator edge thermal limit [12].

To avoid overheating in the rotor windings, the field current sent into the generator's rotor windings is limited [10]. Hence, the magnetic field in the machine and the voltage at the terminals will be limited as well. The limitation in field current is very important in order to avoid overloading of the generator, as generator overloading mainly is caused by high currents [8]. A limiter providing this restriction in field current is often called overexcitation limiter (OEL). This type of overexcitation limiter is usually applied on all large synchronous generators [13]. The OEL will restrain the synchronous generator's capability to supply reactive power.

In addition to overexcitation limiters, underexcitation limiters (UELs) should be applied. The UEL's task is to prevent overheating in the stator windings. It should also prevent the steady-state stability limit from being exceeded [14][11]. When the generator is absorbing too much reactive power in an underexcited state and the stability limits are exceeded, the rotor angle can reach 90° and consequently the generator will step out of phase [15]. This is called pole slip. The UEL should control the field current such that the lower limit for the field current is not crossed. In this way the UEL will restrain the synchronous generator's capability to absorb reactive power, and a too low magnetization could be avoided.

The generator's apparent power is determined by the current in the armature windings. Thus, this also applies for the active and reactive power. This is shown in the following equations.

$$S = 3V_\phi I_A \quad (13)$$

$$P = 3V_\phi I_A \cos \theta \quad (14)$$

$$Q = 3V_\phi I_A \sin \theta \quad (15)$$

These equations form the basis for the reactive capability curve, indicating safe operating points for the generator. Figure 6 shows a generator phasor diagram with lagging power factor. This can be converted into a new diagram including the corresponding power units, as shown in figure 7. This is done by rewriting the equations for P and Q [10].

$$P = 3V_\phi I_A \cos \theta = \frac{3V_\phi}{X_S} (X_S I_A \cos \theta) \quad (16)$$

$$Q = 3V_\phi I_A \sin \theta = \frac{3V_\phi}{X_S} (X_S I_A \sin \theta) \quad (17)$$

By applying these formulas, and taking into account that the origin of the phasor diagram is at $-V_\phi$, the reactive capability curve can be obtained. An example of such a curve is given in figure 8. Any operating point within the shaded area are considered to be a safe operating point for the generator.

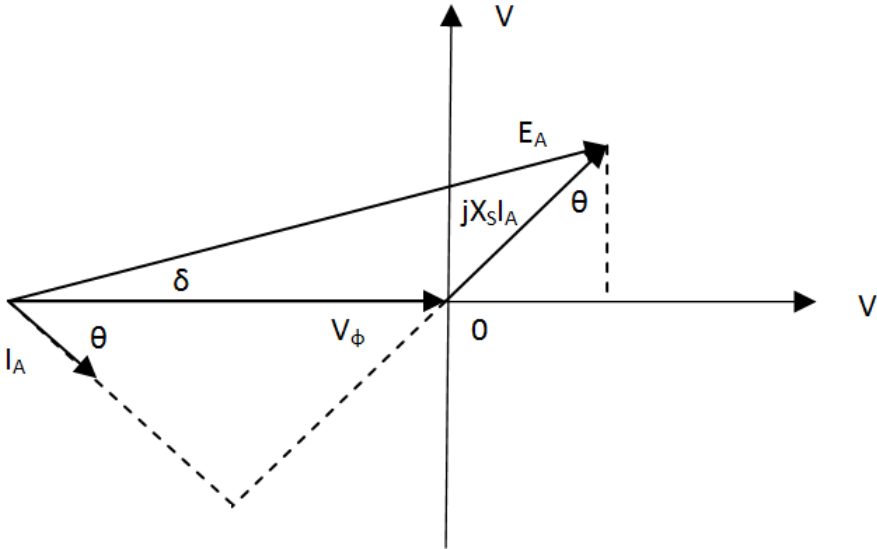

Figure 6: Generator phasor diagram for a lagging power factor

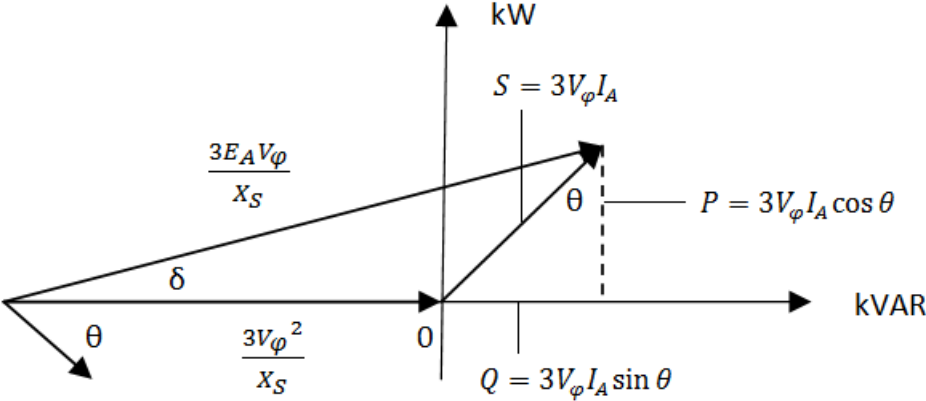

Figure 7: Generator phasor diagram with power units for a lagging power factor

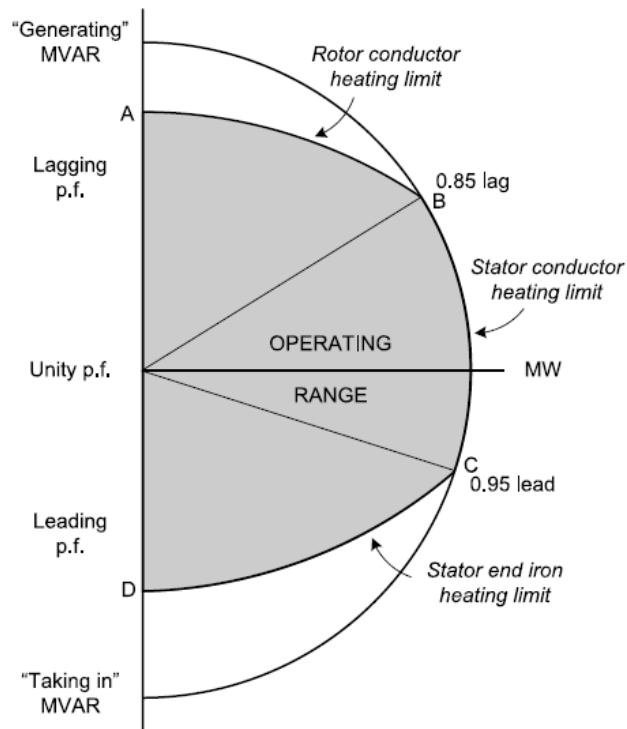

Figure 8: Reactive capability curve [8, p. 117]

2.1.6 The Automatic Voltage Regulator

An AVR typically receives set values and measurements of voltage and current. As mentioned in section 2.1.3, it will give the exciter instructions for how to act. The AVR is of significant importance in order to maintain desired voltage at a specific point in the grid, and make the exciter able to deliver an appropriate amount of magnetization current [3]. Statnett, the Norwegian TSO, demands that all generators with ratings above 1 MVA should have AVR's applied [1].

Without an AVR the generator would not be able to adjust the production of reactive power independently of the terminal voltage. The VQ-relation is then given by the synchronous generator's VQ-curve, as shown in figure 5. An increased voltage at the terminals would then imply less production of reactive power. A decreased voltage at the generator bus would, on the other hand, lead to an increased generation of reactive power. Not having an AVR therefore implies that the generator would not be able to give a contribution to voltage control. The generator would then simply adjust to the system.

If an AVR is applied, the generator will be able to adjust the reactive power supply, and a constant voltage can be obtained at the terminals. This is due to the AVR and exciter. For a lower voltage at the terminals, the AVR will give the exciter instructions to increase the field current. Consequently the terminal voltage rises while the reactive power supply decreases. With an AVR installed, the generator can also operate at a voltage level different from the system's nominal level. This can be beneficial if a generator is connected to the grid in a point where the voltage tends to be too low, due to long transmission lines with high losses, etc.. The voltage set point for the AVR can then be modified such that the generator operates at a slightly higher voltage level. In this way the voltage in the area can be increased. The set point of the AVR should be chosen in order to obtain the desired voltage level, and must be adjusted dependent on the generators point of connection in the grid.

Often the AVR is a PID controller with proportional, integral and derivative operation. The purpose of a PID controller is to obtain a fast control, and secure that the stationary deviation is small [16]. The typical transfer function of a PID controller is given below. Parameter K_p represents the proportional constant, T_i is the integral time constant and T_d is the derivative time constant.

$$H_r(s) = K_p \frac{(1 + T_i s)(1 + T_d s)}{T_i s} \quad (18)$$

To get an optimal control system, the parameters in the controller have to be tuned such that desired properties are obtained. If a pure proportional regulator is used there will be a stationary deviation, which is not favourable [16]. The controller must therefore include other functions in addition to the proportional. If the integral impact, $\frac{K_p}{T_i}$, is too large the system, and hence the voltage, will be exposed to an unnecessary large amount of oscillations. On the other hand, if $\frac{K_p}{T_i}$ is too small, the response of the signal will be too slow. The derivative impact can contribute to fast control. This impact should though not be too large as this can cause unwanted disturbances [16]. The transfer function will though not be commented further in this report.

2.1.7 The AVR's Droop Function

It is possible to change the specific characteristics related to a generator's operation. I.e., the characteristic for voltage and reactive power can be adjusted to a suitable level, dependent on the grid in which the generator is connected. The generator can

then give an appropriate contribution to keeping the voltage level. Also, the characteristic for frequency and active power can be modified. The latter characteristic will not be further commented in this section. To be able to adjust the characteristic for voltage and reactive power, some type of modification is needed. In this context modification means a functionality which makes it possible to change the characteristics for a generator. The modification requires measurements of voltage and/or current delivered by the generator.

Modification is often used in excitation systems. For synchronous generators, both active and reactive current compensation are commonly used [17]. One type of modification is the droop compensation, providing a voltage decline for increased delivery of reactive power. Another type of compensation is referred to as line-drop or transformer-drop compensation, giving an increasing voltage at the generator's terminal for an increased output of reactive power [17]. This compensation can hence be regarded as a negative droop, and will hereafter simply be referred to as compensation. The resulting VQ-characteristic for a generator, considering reactive droop or compensation, defines the generator's ability to account for imbalance in reactive power, at the cost of a deviation in voltage. In this thesis the effect of both reactive droop, also called droop, and compensation, i.e. negative droop, will be studied.

The droop or compensation is provided by including an additional loop to the AVR. This loop consist of an adjustable virtual impedance [11]. The modified voltage sent into the AVR is a summation of the terminal voltage and the voltage across the compensating element [11]. The modified voltage is often obtained by taking in a measurement of the reactive current delivered from the generator, and multiplying it with a constant. The goal is to operate the generator in such a way that the voltage signal sent into the AVR's PID controller approaches zero. The following equation shows how the modification is implemented in the AVR. In the remaining parts of this section the focus will be on reactive droop.

$$V_{ref} + V_S - V_C = 0 \quad (19)$$

$$V_C = Z_{droop} I_r \quad (20)$$

Here V_{ref} is the reference voltage given to the AVR, V_S is the voltage from the PSS, and V_C is the compensated voltage. The reactive current component, I_r , will be positive for a lagging load [17]. Consequently the voltage signal to the AVR will be negative for an increased inductive load current. The excitation provided to the generator will then be reduced, and the generator will deliver more reactive power. For an increasing capacitive load, the voltage signal sent to the AVR will be positive. The supply of reactive power from the generator will then be reduced.

A sketch of a simple excitation system is shown in figure 9 below.

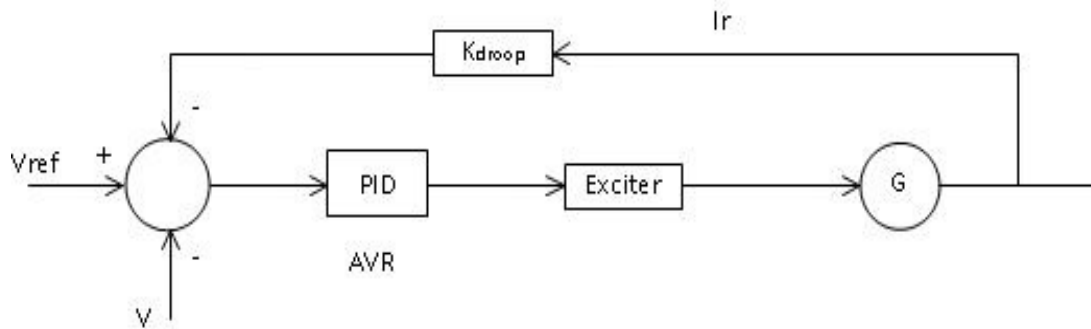

Figure 9: Sketch of a simple excitation system including droop

If the droop function is not included in the AVRs, the VQ -relation would be horizontal [17]. This implies that a change in reactive power, delivered or absorbed by the generators, would not affect the voltage at the generator buses. As mentioned in section 2.1.6, the voltage at the generator's terminal could then be kept constant. In such a case the generators could experience very large changes in the amount of supplied or absorbed reactive power. As a consequence, the generators might try to deliver or absorb an amount of reactive power which exceeds the excitation limits. Without a droop function the generator would at all times try to adjust the supply or absorption of reactive power, and the generator would most likely experience going into saturation. A generator with no droop installed can therefore give a contribution, to maintain a desired voltage level, which is too large.

By including a droop function in the AVR, the generator will be able to contribute to voltage control in a more suitable manner. The contribution to keep the voltage level constant will though be somewhat less when droop is included, compared to the case without any droop. If the droop is properly adjusted, the probability of avoiding generator saturation will increase. This contributes to a more safe and stable generator operation. Hence, droop should be included if there is a risk of saturation. A large droop will give small variations in reactive power, and hence some larger deviations in voltage. With a smaller droop the voltage level will be more stable, but the generator will experience larger variations in the reactive power supply. The droop must therefore be tuned to a level suitable for the grid in which the generator is connected.

The droop can be calculated from values of voltage and reactive power. The equation used to calculate the reactive droop is given in equation (21) below.

$$Droop_{gen} = \frac{\Delta V_{gen}[p.u.]}{\Delta Q_{gen}[p.u.]} = \frac{V_{gen}(min) - V_{gen}(max)}{\frac{Q_{gen}(max) - Q_{gen}(min)}{S_{gen}}} \quad (21)$$

A droop characteristic is shown in figure 10.

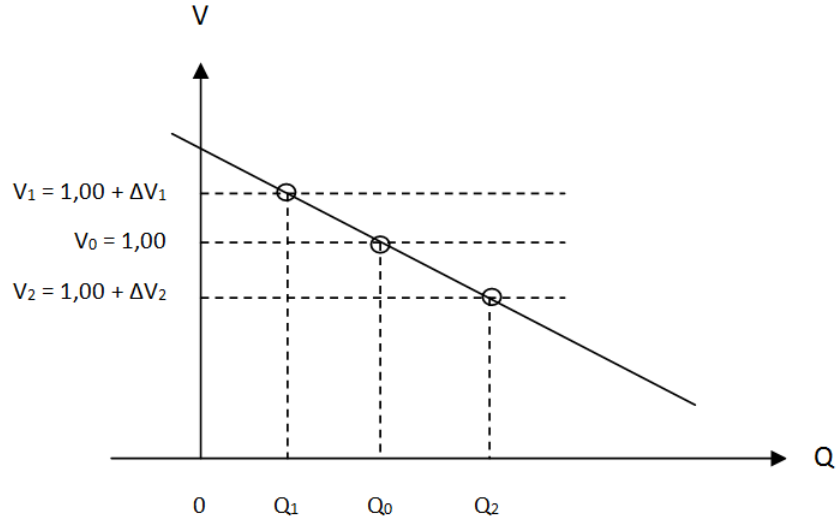

Figure 10: Droop characteristic for voltage and reactive power

Since the AVR has an impact on the relationship between voltage and generated reactive power, it is clear that changing the AVR's set point will influence the generation or absorption of reactive power. Changing the set point allows the generator to operate at another voltage without changing generation or absorption of reactive power. Similarly, the generator can operate at the same voltage level while delivering or absorbing a different amount of reactive power. This is shown in figure 11 for two different voltage levels, 1,0 p.u. and 1,0 + ΔV p.u.

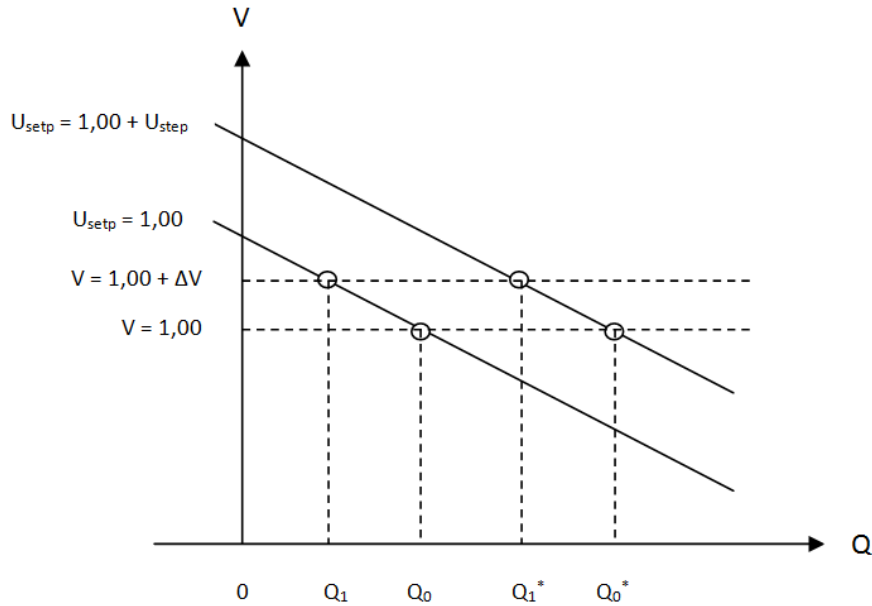

Figure 11: Droop characteristic for voltage and reactive power when changing U_{setp}

Sharing of reactive power between generators is an important issue, and it is affected by the AVR's droop settings. If generators within the same area have droop settings that differs much from one another, there is a risk of getting circulation of reactive power. Hence, the losses in the system will increase. To avoid this problem, it is important to adjust the droop settings for the AVR's to a suitable level. Differing set points can also cause unfavourable sharing of reactive power. Having generators with very different set points within the same area should therefore be avoided. This implies that tuning of droop and selection of set points are important in order to obtain optimal operating conditions.

2.1.8 Generators in Parallel

In some cases it can be beneficial to have several generators connected in parallel, instead of having only one larger generator. When having paralleled generators, the power station will still be able to deliver electricity if one or more machines are out of service, due to e.g a fault or planned maintenance activity. This increases the reliability of the power system [10]. Another great advantage of having smaller generators in parallel, is that it allows the power producer to operate the machines more optimally. This means that some machines can be operated at al-

most full loading, instead of having one large machine operating far away from the favourable operating point. The power producer can therefore utilize the machines more efficiently [10].

Besides the benefits of having generators connected in parallel, there are also some issues related to this configuration. Some of them are related to the AVRs. If two machines are connected in parallel, their AVRs can start to oppose each other. In this case, if the voltage at the common generator bus decreases, the AVRs will receive a signal which tells them to increase the production of reactive power. If one AVR responds slightly faster than the other one, opposing generator behaviour can occur. The AVR responding first will supply or absorb more reactive power, compared to the AVR with slower response [18]. Slightly different set points for the generators will also cause opposing generator behaviour. If one AVR has a set point slightly above the desired voltage level, while the other AVR has a set point which is a little below this level, they will act in opposite ways [18]. The opposing tendency will last, and the AVRs will continuously work against each other. The situation with opposing AVRs is not desirable as it leads to circulation of reactive power, and hence unnecessary generation of reactive power. This gives unwanted consequences, such as less capability to increase generation of active power, as mentioned in section 2.1.1.

For generators operating in parallel, it is often necessary to apply a droop functionality to obtain a suitable sharing of reactive power between the generators [11]. The reactive droop provides less sensitivity to voltage changes, and hence the probability of having generators opposing each other is reduced. The droop functionality consequently provides a proper sharing of reactive power between parallel units [11].

2.1.9 General Ways to Control Voltage and Reactive Power

The flow of reactive power in the grid, and hence the voltage can, as already mentioned, to some extent be controlled by synchronous generators. The reactive power supplied or absorbed by a synchronous generator is mainly dependent on delivered active power, thermal limit capability and the allowed range of the terminal voltage [12]. A typical range for the generator's terminal voltage is $\pm 5\%$ [12]. By adjusting the voltage set point, the generator's reactive power generation or absorption can be increased according to the generator's VQ-characteristic. Voltage control by adjusting set points will be further commented in section 4.

In addition to utilizing synchronous generators to control reactive power, other strategies can be used. The control of voltage and reactive power can e.g. be performed by other VAR generators, such as other rotating electrical machines and static power electronics converters [12]. Among static power electronics converters, FACTS devices like SVC (static VAR compensator) and STATCOM (static synchronous compensator), and UPFC (unified power flow controller) are common [12]. These devices' main purpose is to supply the grid with capacitive or inductive power [19]. The components should also improve the efficiency of the transmission network and the quality of the transmission [19].

Earlier, mechanically switched capacitor banks and reactors, both connected in parallel to the grid, were used to a larger extent than today. The capacitor banks should increase the voltage during periods with heavy loading, and the reactors should, on the other hand, prevent overvoltages from occurring during periods with lower loading [19]. The grid development have introduced a need for faster and more precise control of reactive power compensation to better control various transmission conditions [19]. Hence, faster thyristor-switched or thyristor-controlled components, such as SVCs and STATCOMs, are required.

The SVC is a static VAR generator (SVG) that can draw both capacitive and inductive current from the power system, and hence vary the reactive power supply or absorption [12]. The SVC's main task is voltage support, and it should improve the grid's power transmission capacity by controlling the voltage [12]. A SVC is a reliable device that quickly controls the voltage, reduces losses, and prevents overvoltages at low loading conditions [20]. This type of FACTS devices is connected in parallel to the grid.

The STATCOM is a static synchronous generator which is shunt-connected and operated as a static VAR compensator [21]. The capacitive or inductive output current can be controlled independent of the AC system voltage [21]. Consequently the STATCOM can provide variable reactive power that increases voltage stability and improves the power quality [22]. Compared to a synchronous compensator/condenser, which is a synchronous machine running without a mechanical load, the STATCOM has no inertia causing lower investment, operating, and maintenance costs [12]. The STATCOM is efficient for buses with low short circuit capacity [12].

The UPFC is a static synchronous series compensator that can provide an output voltage which is controllable in both amplitude and phase [12]. This voltage is added to the grid voltage, and hence the active and reactive power flow in a line can be controlled [12]. A drawback with this device is the cost and complexity, and

as a consequence it is not used for voltage and reactive power control [12]. The cost can, on the other hand, be justified for control of active power transfer [12].

There are several ways to control voltage and reactive power flow. The regulation provided by the power producers is mainly given by the synchronous generators, whereas the grid operators are utilizing other components in order to achieve a desired control. The grid operators must therefore include regulation equipment in the power system if the contribution from the power stations is not sufficient. A further discussion of this topic is given in section 10.2.

2.1.10 Introduction to Statnett's Demands Regarding Voltage and Reactive Power Control

Statnett requires that all synchronous generators, with ratings higher than 1 MVA, should be able to operate within $\cos \phi$ limits of 0.86 for a lagging power factor and 0.95 for leading power factors [1]. Similar limits are also shown in figure 8 in section 2.1.5, and they are considered to constitute a typical operating range [8]. I.e., excitation limiters should not reduce the reactive supply relative to the generator's capability diagram, and generally the AVR should be able to operate freely within the generator's capability limits [1]. As a consequence, the generators with their AVRs can contribute to voltage control.

It should though be mentioned that the operator of the generators must decide what voltage range the generators' droop should be tuned for. If the droop is tuned for an unfavourable interval, the generators will not be able to give a good contribution, even if the generators are operated according to Statnett's requirements regarding $\cos \phi$ limits. There are some limits for various voltage ranges in FIKS, but what voltage interval should be used for droop tuning is not specified. These voltage limits will be commented later, in chapter 4 and in some simulations.

It will normally not be problematic for the power producer to give a contribution within these limits, as the generators are constructed to fulfil the $\cos \phi$ requirement. Due to the design of the generators, the contribution to voltage control will normally not impose considerable economic losses. If the cooling of the machine is poor, a large supply or absorption of reactive power can cause increased thermal losses, and hence poorer efficiency. This will though not be further commented in this report.

From another point of view, it can be argued that power producers should receive some kind of economic compensation for their contribution to control of voltage and

reactive power. This is due to the TSO's possibility to lower investment costs in the grid, as the need for additional compensating elements is reduced. In all cases the most important thing is that the TSO and power producer agrees on how the regulation and cooperation should be in order to ensure a secure, stable and reliable power supply.

2.1.11 Introduction to the Voltage Drop Across a Power Transformer

Transformers are important components in the power grid, as they make it possible to transfer power over long distances without having too large losses. Also more power could be transferred when higher voltage levels are utilized [23]. Without transformers there would have been a need of having smaller power stations in the local areas where power is consumed, in order to handle the issues with range and power level [10]. This would have been inefficient [10].

An equivalent circuit model of a power transformer is shown in figure 12 below. The equivalent circuit can be simplified to an approximate model consisting of an equivalent resistance and an equivalent reactance [10]. The transformer introduces a voltage drop due to this impedance. As the resistance is quite small compared to the reactance, the voltage drop will mainly be caused by the transformer reactance. I.e., the transformer reactance gives a good indication to what the voltage drop across the transformer will be. Equation (22) below illustrates how the voltage at the transformer's grid side, referred to as secondary side, is affected by this parameter.

$$V_{secondary} = V_{primary} - Z_t I \approx V_{primary} - jX_t I \tag{22}$$

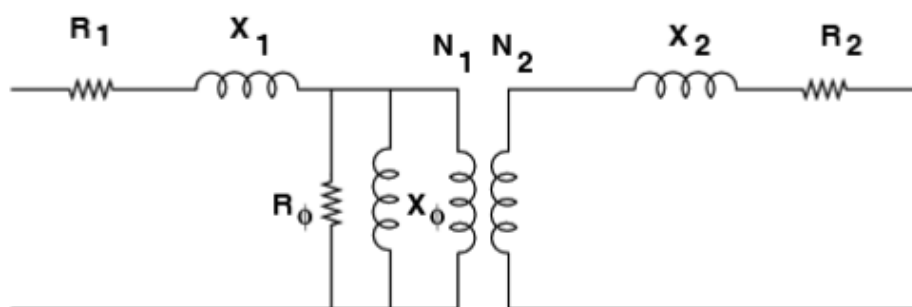

Figure 12: Equivalent circuit model of a power transformer [23, p. 75]

2.1.12 Voltage Control by Measuring on the Transformer's Secondary Side

Utilizing measurements from the transformer's grid side, in this report referred to as secondary side measurements, may be useful in some cases. By utilizing such measurements the voltage drop across the transformer may possibly be taken into consideration in a better way, and stable generator operation may be maintained. Also, there is a possibility that voltage changes in the grid may be handled in a more precise way by measuring on the secondary side, although this is maybe most useful when considering voltage drop over a line as well as across a transformer.

It is though quite unusual to utilize this type of control strategy, and it is primarily only used for exceptional circumstances. For single operated generators it is more common to use compensation to obtain a favourable voltage profile, as the transformer voltage drop can be compensated by having a net compensation at the generator. Secondary side measurements are therefore not necessary when only one generator is connected to the transformer. If there is a special interest in regulating the voltage in some point outside the generator, utilization of measurements from other points than the generator's terminals can be advantageous.

2.2 Frequency and Active Power Control

2.2.1 Active Power Control

The amount of active power delivered by a generator is determined by the torque, or force, applied on the machine by the prime mover [8]. If the generator is to provide more active power to a load, the force acting on the rotor must increase. This is due to a rise in armature current as the load increases. The armature current is therefore dependent on the load, and not the generator itself [8]. A higher current in the armature windings implies an increase in the magnetic field perpendicular to the rotor field, i.e. the stator field. As a consequence, the rotor would slow down. A characteristic giving the relationship between power and frequency is shown in figure 13.

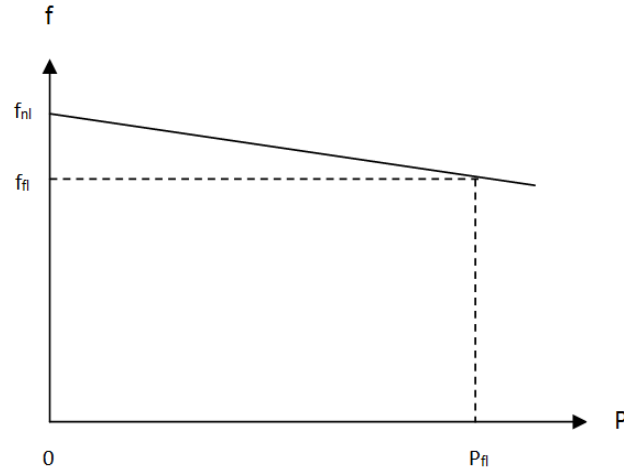

Figure 13: Power vs. frequency curve for a synchronous generator

To maintain a constant rotor speed when the loading is increased, the turbine must provide additional torque [8]. For this to be possible, the inlet of working fluid to the turbine must be increased. If the generator, on the other hand, is to lower the supply of active power, the force acting on the rotor must be diminished. As the load decreases, the armature current and magnetic field will reduce as well. Consequently, the force opposing the turbine torque is smaller, and the generator speed increases [8]. To avoid a lasting increase in speed, the inlet of working fluid to the turbine must be reduced. The inlet is controlled by the governor (GOV), which will be further presented in the following section.

2.2.2 The Governor

While the voltage level at a generator's terminals to a great extent is controlled by an AVR, the frequency in the power grid is largely dependent on the turbine regulator, or the governor. The actions of a turbine regulator, initiated by a change in frequency, is referred to as primary frequency control [3]. When the governor receives measurements indicating that the rotor speed, or electrical frequency, deviates from the set value, it will send signals to the inlet valve through a feedback loop [3]. The valve will then adjust the inflow of working fluid to the turbine. If the frequency is decreasing, the governor tells the inlet valve to open. A larger amount of working fluid will then contribute to increase the turbine speed, and hence the rotor speed. When the rotor regains its determined speed, the frequency will return to the nominal level.

2.2.3 The Speed-droop

For paralleled generating units, the governor can introduce some active droop to the quantities that are to be controlled, in the same manner as the AVR [11]. This is done to ensure adequate and stable parallel operation [11]. As a consequence of the included droop, the slope of the curve shown in figure 13 can be changed. The slope of the curve should be adjusted according to what degree of sensitivity is wanted for the generating unit. If it is desirable for the generator to respond to small changes in frequency, a small active droop should be chosen. This would imply larger variations in the output power. The speed droop is given by the following equation, describing the relationship between change in speed, $\Delta\omega$, and power output, ΔP_m .

$$\frac{\Delta\omega}{\omega_n} = -\rho \frac{\Delta P_m}{P_n} \quad (23)$$

ω_n and P_n denote the nominal values for rotational speed and power. The constant ρ is referred to as the speed-droop coefficient [3]. The droop equation can also be written in terms of the effective gain for the governing system, such that $K = \frac{1}{\rho}$. The relationship between speed and power then becomes as given in the following equation.

$$\frac{\Delta P_m}{P_n} = -K \frac{\Delta\omega_m}{\omega_n} \quad (24)$$

3 System Description

The system to be considered consists of two hydro power stations, Hove and Refsdal, where each plant has two generators connected in parallel. I.e., the two generators in each plant are connected to the grid through a common main transformer. The grid in which the power stations are connected is the distribution grid with a voltage level of 300 kV. The two generators in one power station are similar, i.e. they have the same ratings and parameters. Their AVRs are also of the same type and have similar characteristics. Some essential data about the power stations are given in the tables below. The data was provided by Statkraft.

Generators in Hove power station:

V_{rated}	11 kV
S_{rated}	36 MVA
$\cos \phi$	0.85

Table 1: Characteristic data for the generators in Hove power station

Generators in Refsdal power station:

V_{rated}	8 kV
S_{rated}	57.1 MVA
$\cos \phi$	0.80

Table 2: Characteristic data for the generators in Refsdal power station

Main transformer in Hove power station:

S_{rated}	85 MVA
$V_{rated} \text{ HV side}$	310 kV
$V_{rated} \text{ LV side}$	11 kV
$Coupling$	YNd
$Reactance$	approx. 11 %

Table 3: Characteristic data for the transformer in Hove power station

Main transformer in Refsdal power station:

S_{rated}	100 MVA
$V_{rated HV side}$	310 kV
$V_{rated LV side}$	8 kV
<i>Coupling</i>	YNd
<i>Reactance</i>	approx. 11 %

Table 4: Characteristic data for the transformer in Refsdal power station

The AVRs in the two power stations are PID controllers of type HPC 185, delivered by ABB Alstom. The droop settings for the AVRs, related to reactive current, are set to 5% and 10% in Hove and Refsdal respectively. Information about the AVRs was given by Statkraft and Hymatek. The control system's manner of operation for these specific power stations will be further commented in chapter 4. The figure below shows the main components in the HPC 185 AVR.

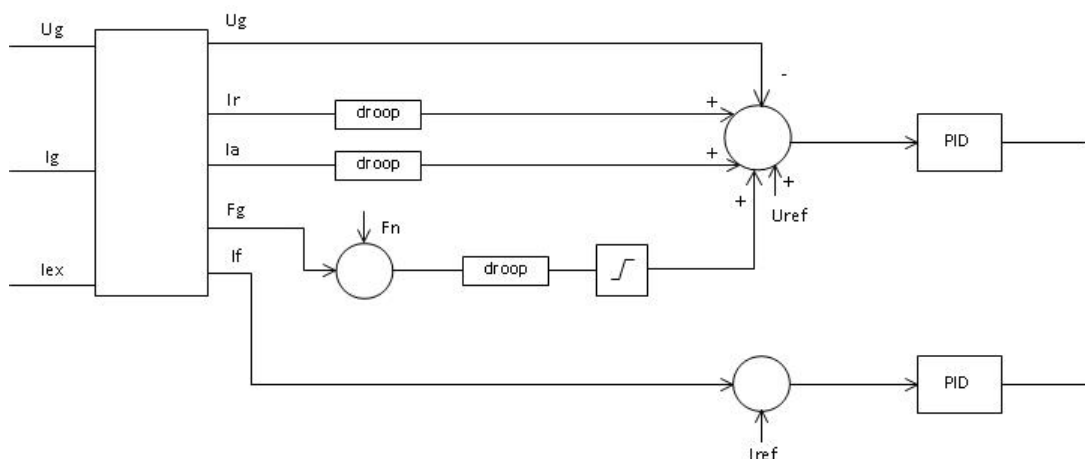

Figure 14: Main components in the HPC 185 AVR

The power stations that are considered in this report are connected to a grid where the active power mainly flows from the main generating area, Fardal, towards the main consuming area, Modalen and Bergen. There are mainly two operating conditions which are of interest for Statnett, those are a heavy loading situation and a light load situation. For the heavy loading situation the active power flows towards Modalen and the consuming area only, and for the light loading situation the active power is flowing from the two power stations towards both connected areas. In this project the scenario with heavy loading will be considered in most of the simulations, unless anything else is specified. Information about the load flows for

these different scenarios were obtained from Statnett's grid model, Norgesmodellen. Norgesmodellen also contained line data for the system to be studied. Information about load flows and line data will not be given in this report in order to comply with §6.2 in the Norwegian regulation "Forskrift om forebyggende sikkerhet og beredskap i energiforsyningen (beredskapsforskriften)". Such information, relevant for the models and simulations, will therefore only be given to the evaluators in an additional, confidential attachment to this report.

4 Voltage Control in the System to Be Studied

As mentioned in section 1.1, the voltage control in the system to be studied is obtained by adjusting the generation or absorption of reactive power, by manually changing the set point for reactive power. The system voltage determines the set point for the reactive power production. Hence, the actual voltage control is achieved by adjusting the reactive set point. A change in reactive set point will have the same effect as changing the voltage set point, according to the AVR's VQ-characteristic, as shown in figure 11 in section 2.1.7. The reactive set point is given by the system control centre, while the adjustment is executed by the local control centre. I.e., the operator manually determines the set point from a scheme, and the AVRs will try to attain this value. The controllers in the two power stations are receiving measurements of current and voltage from the main transformers' generator side.

The scheme used for the control consists of a table containing values for voltage and reactive power. The reactive power is calculated based on the grid voltage, transformer reactance, droop and the generator's capacity. The transformer's reactance must be taken into account, as it introduces a voltage drop dependent on the size of the reactance. This was mentioned in section 2.1.11, and equation 22 showed how the voltage at the secondary side were affected by this reactance.

In the scheme the reactive power is calculated based on the value for maximum reactive power generation of a machine. However, in this thesis the droop will be calculated based on the generator's rating, i.e. rated apparent power, according to equation (21) in section 2.1.7. The reference value for the grid voltage used in the calculations is not adjusted unless Statnett is specifically requesting it, which is highly unusual. I.e., the reactive power supply is mainly determined by the deviation from the desired system voltage. The regulation scheme utilized today is not referring the transformer reactance to the generators' ratings. This is a drawback with the regulation scheme, as it does not consider the change in voltage drop across the transformer dependent on the number of generators that are operated. When not referring the transformer reactance to the capacity of the operating machines, the reactive power supply might not be suitable for that operating state. When only one generator is operated, the voltage drop across the transformer will be approximately halved, compared to the case with two generators operating.

The current control strategy of these power plants is quite different from what is considered as a typical control strategy. The reason for why the control is carried out in this way is that there were instability problems for the paralleled generators

when the power stations were commissioned, as the generators were working against each other. This could be a result of an unfavourable droop tuning, etc.. To avoid this instability, it was at the time decided to utilize a control strategy as described above, instead of a more common strategy not adjusting the set point. By making use of the described strategy, Statkraft's goal is to contribute to voltage control by adjusting reactive power production to meet Statnett's demands.

As mentioned in section 1.1, Statkraft wants to be able to control the voltage without having to manually give a set point for reactive power from a scheme, as the current control is somewhat cumbersome. It is therefore desirable to utilize a control strategy that automatically handles voltage and reactive power based on the system's condition. The control system should thus be changed such that the regulation is directly adapted to the grid voltage, without having to manually adjust the reactive power supply. Statkraft also wants the paralleled generators to communicate in a proper way, such that opposing generator behaviour can be avoided. The communication, i.e. the sharing of reactive power, is usually provided by a droop functionality. In order to have an efficient control of voltage and reactive power, it is also important to tune this droop properly. This will be discussed later in the report.

As the control is based on adjusting the set point, the supply of reactive power is probably smaller than what it could have been. This is because the AVR will detect a smaller deviation between the actual measured value and the set point, if this set point is adjusted according to the system's state. The generators in Hove and Refsdal have reactive droops of 5% and 10% respectively, as mentioned in chapter 3. When taking the transformer reactance of 11%, referred to the transformers' ratings, into account, the resulting droop at the transformers' secondary sides would then be about 16% and 21%, when both generators are operated. But when considering the scheme used for the current control, the effective droop at the transformers' secondary sides were found to be about 33% and 38%. I.e., the actual effective droop is much larger, in fact about doubled, than what the tuning of the AVRs implies. This means that today's control strategy, changing the reactive set points, provides a smaller contribution to voltage control than what was expected when only considering the droop setting and the voltage drop across the transformer. The VQ-characteristics for Hove and Refsdal according to the current regulation are given in figure 15 below. The voltages in p.u. in the figure corresponds to a voltage range from 260 kv to 340 kV, which is the voltage range that Statkraft currently considers in the scheme.

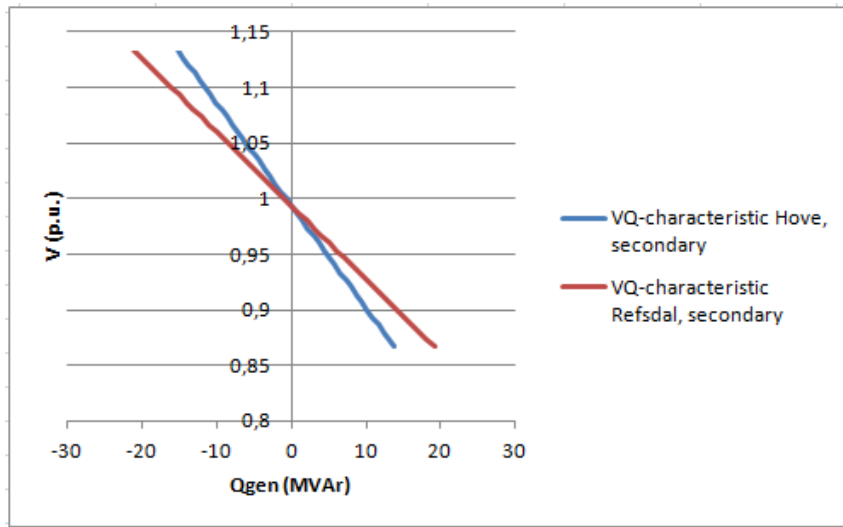

Figure 15: VQ-characteristics for the secondary side in Hove and Refsdal power stations, when considering the current regulation scheme

When considering the values for voltage and reactive power in the regulation scheme, which implies a larger droop than what was expected based on the tuning and transformer reactance, it can be understood why the set points must be adjusted. If the values for voltage and reactive power in the scheme, providing little contribution, represent the desired reactive power supply according to the producer's opinion, the set points must be adjusted as the droop setting and reactance are not providing enough droop on the secondary side. Figure 16 below shows how the reactive set points must be changed in such a case. A simulation investigating the principles of today's regulation will be discussed later in this report.

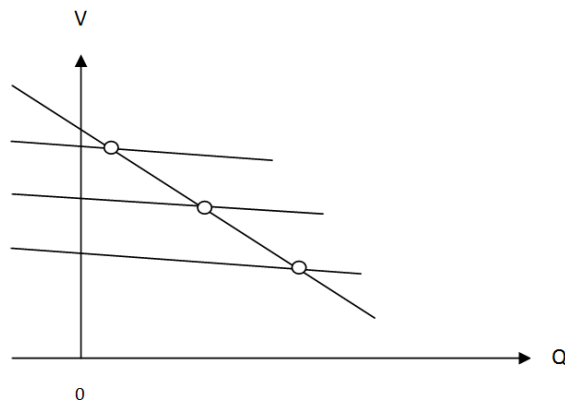

Figure 16: Illustrating how the set points must be changed, when the droop on the transformer's secondary side is less than the droop in the regulation scheme

Other possibilities to solving this problem, other than adjusting the set points, could be to change the regulation scheme, as the generator might be able to give a larger contribution to voltage control. This could be done by reducing the voltage range that the scheme is based on, and hence a smaller droop is obtained. In this way the operator would only have to adjust the set points when the voltage goes out of this specific range. Hence, the control will be improved, as the need for set point adjustments will be reduced. If the power producer wants to regulate according to the scheme, the droop tuning of the generator could be changed, such that the generator provides a larger droop. This will though not be the best solution regarding the overall control of the system, as the contribution to voltage and reactive power control will be quite small.

If the power producer was, on the other hand, not able to deliver the amount of reactive power that was requested, i.e. the droop on the transformer's secondary side was too large compared to the contribution the power producer wanted to give to voltage and reactive power control, the reactive set points must also be changed. The set points must then be changed in order to keep a desired voltage level that is in correspondence with the system voltage. Figure 17 below shows how the reactive set points must be changed in such a case.

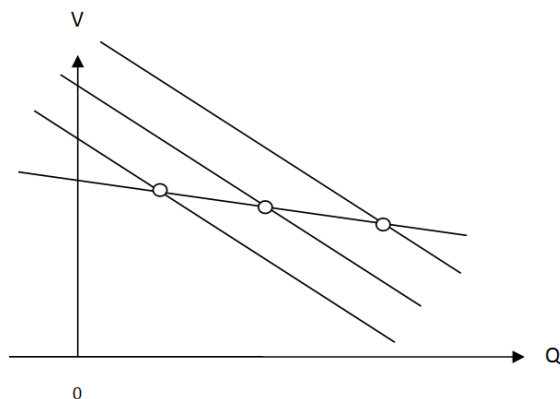

Figure 17: Illustrating how the set points must be changed, when the droop on the transformer's secondary side is larger than the droop in the regulation scheme

Other possibilities to solving such a case, without adjusting the set points, could be to lower the droop at the generators' terminals, if this is possible without introducing instability. Also the scheme could be adjusted.

When considering the droop obtained at the transformer's secondary side, when taking the continuous voltage limits and requirements regarding reactive power supply in FIKS into account, the resulting droop becomes much less. As mentioned in section 2.1.5, Statnett requires that all synchronous generators, with ratings higher than 1 MVA, should be able to operate within $\cos \phi$ limits of 0.86 for lagging power factor and 0.95 for leading power factors [1]. The reactive powers that have to be supplied by the power stations in order to comply with this requirement are given in tables 5 and 6. The voltage limits for continuous operation in FIKS are set to 280-300 kV, or 0.93-1.00 p.u. [1]. The resulting droop at the transformers' secondary side then becomes approximately 8.51% for both power stations. The resulting VQ-characteristic for this case is given in figure 18 below.

Reactive power for the generators in Hove power station:

$$\begin{aligned} Q_{max} & 18.96 \text{ MVar} \\ Q_{min} & -11.24 \text{ MVar} \end{aligned}$$

Table 5: Reactive power generation in Hove, when considering Statnett's requirements for voltage control

Reactive power for the generators in Refsdal power station:

$$\begin{aligned} Q_{max} & 30.08 \text{ MVar} \\ Q_{min} & -17.83 \text{ MVar} \end{aligned}$$

Table 6: Reactive power generation in Refsdal, when considering Statnett's requirements for voltage control

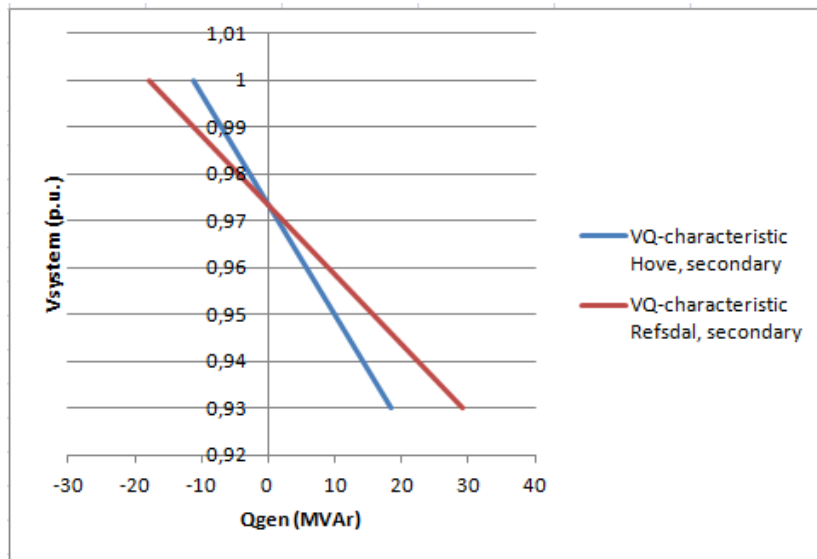

Figure 18: VQ-characteristics for the secondary side in Hove and Refsdal power stations, when considering the continuous voltage limits in FIKS

If the transformer reactances in Hove and Refsdal are referred to the total generator capacity when two generators are operating, their values are approximately 9.32% and 12.56% respectively. This means that when both paralleled generators are operated, the droop at the secondary side will be larger than the droop of 8.51% calculated from the information in FIKS and the generators' ratings. In fact, the transformer reactance alone will create a larger droop. As paralleled generators also require some droop at the terminals, the effective droop at the secondary side will be even larger. This means that the transformer reactance limits the minimum droop that could be on the secondary side when operating paralleled generators. Simulations studying these topics will be discussed later in this report. Statnett's requirements regarding voltage and reactive power control will also be commented later, in section 10.3.

5 The Simulation Programme DIgSILENT PowerFactory

The simulation programme used in this project was DIgSILENT PowerFactory. This was also the program used in the specialization project autumn 2015. The program has a graphical user interface, and makes it possible to model power systems and analyse their behaviour and interaction. The software can be used for analysing ordinary power flows, faults, voltage stability, contingencies etc.. Several models for turbine governors, AVRs, PSSs, etc., are implemented in the software, but the user can also make own models or modify the designs that are already implemented.

Only a few of the many functionalities included in PowerFactory were utilized in this project. One of them was the ordinary load flow analysis, which is not a dynamic analysis. The other functionality utilized was the RMS simulation. This is a time domain simulation that can provide information about system dynamics [24]. The RMS simulation was used to analyse the modelled system's behaviour when investigating the effects of applying droop and compensation, and moving the measurements given as input to the AVRs.

6 Modelling of the System

In order to investigate the system's behaviour with respect to voltage drop across the transformers, droop, compensation, and the effect of using different measuring points, some models must be made to carry out the simulations. As mentioned in chapter 5, the simulation programme used was DIgSILENT PowerFactory, hereafter called PowerFactory. In this chapter the modelling of the system will be described, and simplifications and assumptions will be presented.

6.1 Simplifications in the Models

It was decided to make some simplifications when modelling the system. This was due to the large amount of data that would have had to be collected in order to make very accurate models. It was therefore decided to use simpler models that still were suitable for the simulations that were to be done. The models used in the simulations were pretty much similar to the models made for the specialization project *Voltage Control and Sharing of Reactive Power*. In addition some changes were made, e.g. to utilize secondary side measurements.

As mentioned earlier in the report, the power stations are connected to a grid where the flow of power is mainly in one direction. It was therefore chosen to model the system with a main generation area and a main consumption area. The generation area was modelled by a large synchronous generator, while the consumption area was modelled by a general load. The grid, in which the power stations are connected, could also have been modelled as an external grid in PowerFactory. When testing this, it was found that there were more limitations in the simulations, and the wanted system behaviour was difficult to obtain. It was therefore more suitable to model the adjacent grid as two areas.

Another simplification of the work is related to voltage and reactive power control. When the effect of taking the measurements given to the AVR from the transformer's secondary side was investigated, the voltage at the grid side was estimated, not measured. The reason for why this approach was chosen, was the practical implementation in PowerFactory, as it turned out that actually taking the measurements from the grid side would be very difficult. However, testing of the system showed that this simplification was working sufficiently.

In the simulations studying the manner of operation for the current control system, it was decided to change the set point for voltage in the power stations. This was done because it would have been difficult to change the reactive set point in PowerFactory. As mentioned in chapter 4, a change in reactive set point will have the same effect as changing the voltage set point, according to the AVR's VQ-characteristic. Hence, it was decided that this was an acceptable simplification.

The two different, simplified models that were made are:

1. One power station, with one single generator, connected to the generation area and consumption area
2. Two power stations, each with two paralleled generators, connected to the generation area and consumption area

The large generator in the generation area was set to be the system's slack bus. For the system with only one power station, having one generator, the generator bus was set to be a PV bus. The generator buses were, on the other hand, set to be PQ nodes for the system with paralleled generators, as there can not be two AVRs controlling the voltage at the same bus. Another simplification was to not include power system stabilizers and excitation limiters in the models. PSSs were not included due to the implementation of the droop functionality, as will be commented in appendix A.1.1.

6.2 AVR, Droop and Compensation

As mentioned in chapter 3, the AVRs utilized in the power stations are of type HPC 185, which is a type of PID controlled AVRs. This AVR was not implemented in PowerFactory, and for the models it was therefore decided to use another type of PID controlled AVR that was already implemented in PowerFactory. The excitation system used for the power stations in the models was `avr_AC8B`, which is an AC excitation system [17]. A sketch of this excitation system is shown in figure 19 below.

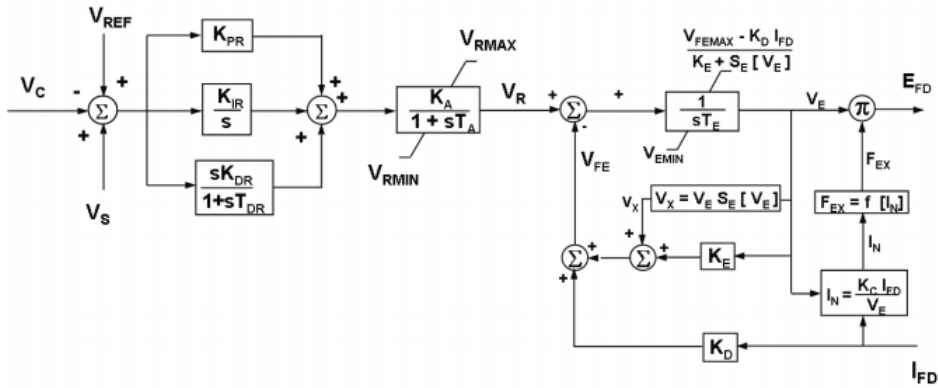

Figure 19: Excitation system of type AC8B used in the two power stations [17, p. 15]

A droop functionality, that could control the relation between voltage and reactive power, was not included for the AVRs available in PowerFactory. A new droop model, with the desired functionalities that could be used for the simulations utilizing primary side measurements, was therefore made. This droop functionality was implemented by PhD candidate Lester Kalemba for the specialization project autumn 2015. The droop was modelled such that the difference in reactive power, between the measured value and the reference value, was taken into consideration. This difference was multiplied with a droop constant and then given as input to the AVR. In the actual system the HPC 185 AVRs receive measurements of voltage and current, but for simplicity it was chosen to use the reactive power measured on the generator terminal as input to the AVRs in this model. Figure 20 below shows how the additional loop providing droop was modelled. The figure also shows that the voltage V_C is given as input to the AVR. A more detailed description of the implementation is given in appendix A.1.1.

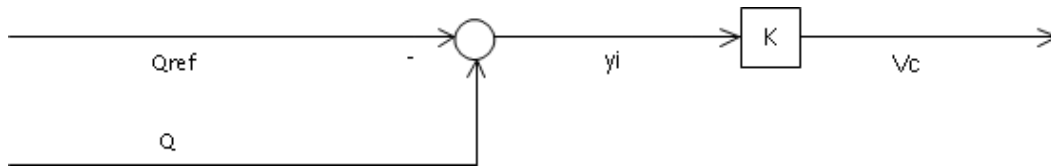

Figure 20: The loop utilized for applying droop and compensation, when the measurements are taken from the transformer's primary side

The relation between voltage and reactive power given to the AVR, should be such that the difference between the reference voltage and the adjustment, due

to variations in reactive power, should approach zero. The equation given below, related to figure 20, shows how the simplified droop functionality works.

$$V = V_{ref} + K(Q - Q_{ref}) \quad (25)$$

Parameter V in the equation represents the voltage deviation, i.e. the difference between the voltage reference and the contribution from the reactive droop. This is the value which is given as input to the AVR. In order to obtain the droop functionality, the generation of reactive power must be reduced for increasing voltage at the generator terminal. Hence, the K constant must be negative. This droop functionality was also used to investigate the effect of applying compensation. By compensation it is in this thesis meant a characteristic which gives increased terminal voltage for increased generation of reactive power. When applying compensation the K parameter must therefore be positive. The voltages in equation (25) are given in p.u., while the values for reactive power are given in MVar. The K constant must therefore be adjusted in order to obtain the desired droop. This was achieved using equation (26). As mentioned in chapter 3, the droop at the generators is of 5% in Hove and 10% in Refsdal in the actual system. The $DroopI_r$ constant is therefore 5% and 10% for Hove and Refsdal power stations respectively.

$$K = -\frac{DroopI_r}{S_{gen}} \quad (26)$$

As this thesis should investigate the effect of moving the measurements to the transformer's secondary side, the models must be adjusted such that it was possible to utilize this type of measurements. The use of secondary side measurements was implemented by using a function in PowerFactory called *drp_COMP*, which made it possible to estimate the voltage in some point outside the generator, e.g. at the transformer's secondary side. PhD candidate Lester Kalemba contributed when this functionality was to be applied in the models. The *drp_COMP* function will in these models take the voltage reference and the current measurement from the secondary side. Equation (27) below shows how the *drp_COMP* function works, and figure 21 shows how this functionality was implemented.

$$V_c = V_{term} - jX_e I_{gen} \quad (27)$$

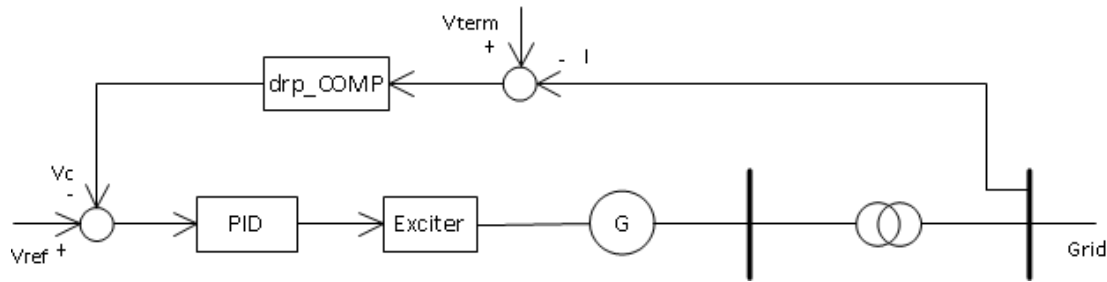

Figure 21: The loop utilized for applying droop and compensation, when the measurements are taken from the transformer’s secondary side

Variable V_c in the equation above represents the compensated voltage, i.e. the voltage given as input to the AVR. The AVR will hence try to control the voltage based on this input. V_{term} represents the voltage at the generator terminal, while I_{gen} is the current from the generator. For the simulations investigating secondary side measurements the current will be measured on the transformer’s secondary side, i.e. at the the high voltage bus closest to the transformer. When studying generators operated in parallel this current will be the total current delivered by both generators. The *drp_COMP* function will also take the reference from the grid side. Parameter X_e can be adjusted depending on the transformer reactance, and what amount of droop or compensation is wanted. I.e., both droop and compensation could be investigated by using this function, and hence the transformer voltage drop could be compensated in order to obtain a more constant voltage at the transformer’s grid side. A more detailed description of the implementation is given in appendix A.1.1.

6.3 Generator and Transformer Data

Data about the generators must also be added to the models. The basic generator information given in tables 1 and 2 in chapter 3, and specific values for time constants, inertia, reactances, etc., were added. The values of these parameters will not be given in this report, as it is not considered as essential information in order to understand the simulations and results. Also, the report should comply with §6.2 in the Norwegian regulation ”Forskrift om forebyggende sikkerhet og beredskap i energiforsyningen (beredskapsforskriften)”, and it was therefore decided not to present this information. Additional information about both generators and transformers, relevant for the models and simulations, will therefore only be given to the evaluators in an additional, confidential attachment to this report.

As mentioned in section 6.1, excitation limiters were not included in the models. Still, Statnett’s demands regarding voltage control, that were mentioned in section 2.1.10, will be considered, and hence the generators must be able to deliver reactive power according to these requirements. I.e., the amount of reactive power that the generators must be able to deliver or absorb, will be taken into account when discussing generator operation. These values are given in the following tables together with the machines’ maximum active power production. The quantities are given for one machine.

Active and reactive power for the generators in Hove power station:

P_{max}	30.60 MW
Q_{max}	18.96 MVar
Q_{min}	-11.24 MVar

Table 7: Active and reactive power generation in Hove, when considering Statnett’s requirements for voltage control

Active and reactive power for the generators in Refsdal power station:

P_{max}	48.54 MW
Q_{max}	30.08 MVar
Q_{min}	-17.83 MVar

Table 8: Active and reactive power generation in Refsdal, when considering Statnett’s requirements for voltage control

Also, transformer data, as given in tables 3 and 4 in chapter 3, was included in the models. The rating of the large synchronous generator in the main generation area was set to 1000 MVA. This was done to illustrate a large production area. The $\cos \phi$ of this machine was set to 0.80, and the inertia was set to 7 s.

6.4 Other Information

As mentioned in the previous section, the AVRs used in the models’ power stations were of the type *avr_AC8B*, which was already implemented in PowerFactory. For the large synchronous machine it was, on the other hand, determined to use a simpler AVR named *avr_SEXS*, which was also already implemented in PowerFactory. The reason for including an AVR for this large generator, was to increase the system’s stability when running the simulations. For both types of AVRs the

default values were used in the simulations. Governors were also applied for the generators in the models, and it was decided to use the same type of governor for all machines. The governor that was applied was of type *gov_HYGOV*, implemented in PowerFactory. As for the AVRs, the default values were kept.

As mentioned in chapter 3, information about load flows and line data will not be given in this report in order to comply with §6.2 in the Norwegian regulation "Forskrift om forebyggende sikkerhet og beredskap i energiforsyningen (beredskapsforskriften)". As for the additional generator data, information about load flows and line data relevant for the models and simulations will therefore only be given in the confidential attachment to this report.

7 Simulations

It was decided to do several simulations to investigate how the voltage and reactive power responses were affected by various factors. The aspects that were studied were changing the system voltage, loading, droop and compensation settings as well as different measuring points. The change in system voltage was simulated by adjusting the voltage set point of the large generator in the main production area. When considering the measurements given to the AVRs, it is most common to take these from the transformer's generator side, as already mentioned. It is in fact quite unusual to take these measurements from the grid side. It was therefore decided to investigate the effect of moving the measurements, and hence measurements were taken from both the generator side, referred to as primary side, and the grid side, referred to as secondary side. Some simulations were also investigating the effect of changing the voltage set point for the AVRs in the power stations, trying to illustrate the current control strategy in the power stations. All the simulations were done using either PowerFactory's RMS simulation or the ordinary load flow analysis. The two systems studied in the simulations are shown in figures 22 and 23 below.

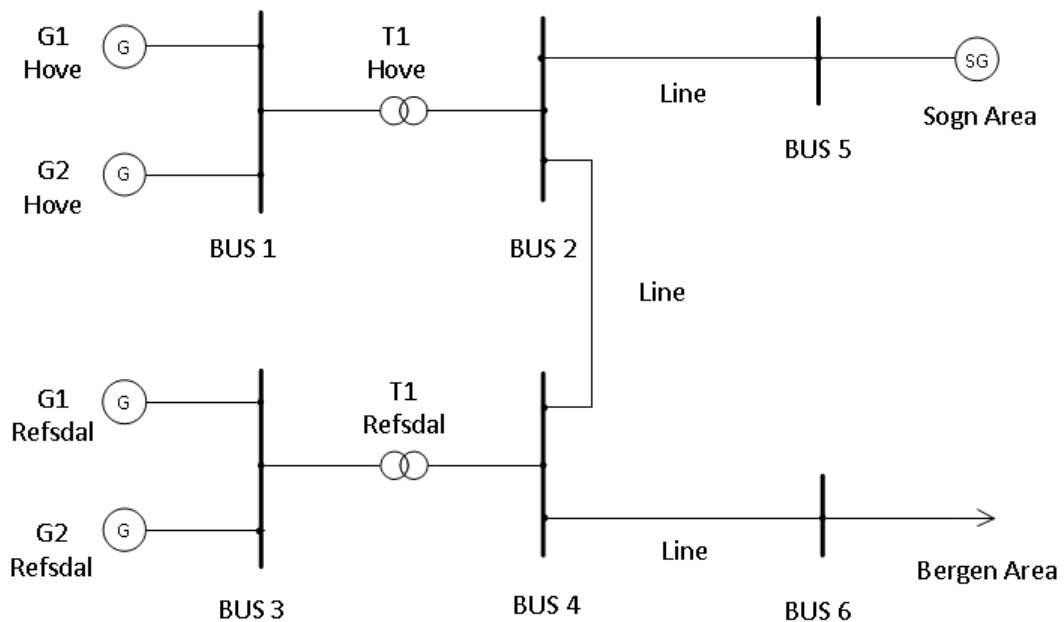

Figure 22: System with two power stations, each having two generators connected to a common transformer

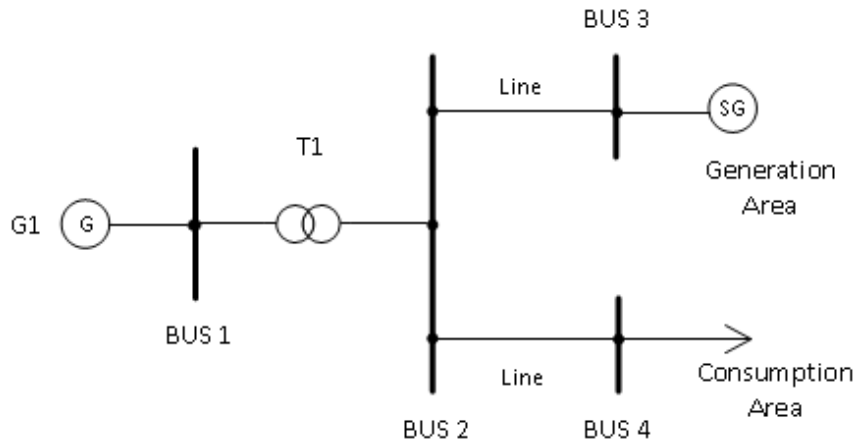

Figure 23: System with one generator connected to the grid

7.1 Investigating the Manner of Operation for the Current Control Strategy

It was decided to do the following simulations for this topic:

1. Adjusting the voltage set point for the generators at the exact same time as the system voltage changes
2. Adjusting the voltage set point for the generators after the system voltage was changed

The simulations presented above were done to illustrate the manner of operation of the current control strategy, adjusting the set point for reactive power based on the voltage changes in the system. In the simulations it was decided to change the set point for voltage in the power stations, as it would have been difficult to change the reactive set point in PowerFactory. As mentioned in chapter 4, a change in voltage set point will have the same effect as changing the reactive set point, according to the AVR's VQ-characteristic, as shown in figure 11 in section 2.1.7. Hence, it was decided that this was an acceptable simplification. The model used was as shown in figure 22. In the first scenario, considering an immediate change in set point, the effect of changing the set point was investigated for two cases, i.e. with and without droop applied. In the second scenario no droop was applied. For all simulations both machines in each power station were operated and loaded equally. The measurements given to the AVRs were taken from the primary side, and the components' ratings were as given in chapter 3.

7.2 Investigating Droop and Compensation, When Considering Voltage Drop Across a Transformer

It was decided to do the following simulations for this topic:

1. Investigating voltage variations with respect to active and reactive power supply
2. Changing the system voltage and loading when there is no droop or compensation applied
3. Changing the system voltage and loading when compensation is applied
4. Changing the system voltage and loading when droop is applied

The first analysis, of the ones mentioned in the list above, was done to investigate how the voltages at the transformers' primary and secondary side were affected by varying system voltage and different active and reactive power supplies. The system to be considered was shown in figure 22, and the system data presented in chapter 3 were applied. The results were obtained by using the ordinary load flow analysis for different cases. The remaining simulations were done to compare the behaviour of the primary and secondary side voltage of the transformer, when applying droop and compensation. The system used in the simulations did not consist of parallel generators, as in the real system, as it was chosen to use a simple system to illustrate the fundamental effects of droop and compensation. I.e., the system showed in figure 23 was utilized. The line connecting the single generator to the main production area, consisting of a large synchronous machine, was set to 300 km in this model. The reason for having such a long line was to reduce the generation area's impact on the voltage in the power station. Also, the rating of the large synchronous generator in the main generation area was reduced to 200 MVA. For these simulations the load was drawing 50 MW and 50 MVA_r. By increasing the line length and reducing the load and capacity of the production area, a weaker grid drawing less reactive power was created. The transformer reactance was set to 11%, and the generator and transformer had ratings of 36 MVA. For simulations 2.-4. the measurements, given as input to the AVR, were taken from the generators' terminals.

7.3 Investigating the Effect of Droop and Compensation, When Taking the Measurements Given to the AVR from the Generators' Terminals

It was decided to do the following simulations for this topic:

1. Changing the system voltage when compensation is studied for one generator in the power stations
2. Changing the system voltage when no droop is applied
3. Changing the system voltage when droop is applied

The simulations presented above were done to illustrate the fundamental effects of droop and compensation, on a system consisting of generators connected to a common transformer, as in the real system. I.e., the model used was as shown in figure 22. Also, a simulation considering one generator operating alone will be considered in the first simulation. In this simulation the generator and transformer data for Hove and Refsdal were utilized, and both a strong grid, based on the data presented in chapters 3 and 6 with a large generator in the production area and a load drawing much reactive power, and a weak grid, as described in section 7.2, containing a weaker generation area, smaller load, and longer line, will be studied. This simulation, considering one generator, might indicate what contribution one generator could give to voltage control. As this simulation was considering the two power stations separately, it was decided to only present the results from Hove in this report. The results for Refsdal will be presented in appendix A.2.2. For the remaining simulations of this section, investigating the effect of droop and compensation, both machines in each power station were operated and loaded equally, except when studying unideal operating conditions. The components' ratings were as given in chapter 3. For all simulations the measurements given to the AVRs were taken from the transformer's primary side, i.e. the generators' terminals.

Similar simulations were partly done in the specialization project, but in order to be able to compare the effect of utilizing secondary side measurements to the effect of using measurements from the generators' terminals, it was chosen to include them in this report. Also, these simulations will focus on the secondary side voltages in addition to the primary side voltages, unlike the specialization project.

7.4 Investigating the Effect of Droop and Compensation, When Taking the Measurements Given to the AVR from the Transformer's Secondary Side

It was decided to do the following simulations for this topic:

1. Changing the system voltage when compensation is studied for one generator in the power stations
2. Changing the system voltage when no droop is applied
3. Changing the system voltage when droop is applied

As already mentioned, the change in reactive power supply is in the current system based on measurements of voltage and current taken from the transformer's generator side. For some cases it can though be advantageous to move the measurements to the transformer's secondary side. By utilizing secondary side measurements, the generators' AVRs may possibly be able to respond to changes in the power system in a better way, and the control may become more precise, as mentioned in section 2.1.12. It was therefore decided to investigate whether moving the measurements would lead to a better control of paralleled generators or not.

The system used in the simulations consisted of power stations with paralleled generators as shown in figure 22. For the first simulation only one generator was operated, and both a weak and a strong grid, were considered. This was done to investigate the effects of secondary side measurements and voltage drop across the transformer when only one machine was operated. As mentioned in section 7.3, this simulation might indicate what contribution the generator could give considering voltage control. Since this simulation was considering the two power stations separately, it was decided to only present the results from Hove in this report. The results for Refsdal will be presented in appendix A.2.3. Similar to section 7.3, both generators in each power station were operated and loaded equally for the remaining simulations, except when studying unideal operating conditions, and the components' ratings were as given in chapter 3.

For these simulations, utilizing secondary side measurements, the voltage at the secondary side was estimated by means of the total current going through the transformer, and then given as input to the AVRs, as described in section 6.2. The reactance in the estimation function was adjusted in the different simulations, to illustrate the effect of including droop and compensation.

7.5 Trying to Tune the Droop Settings for Various Voltage Ranges

It was decided to do the following simulations for this topic:

1. Tuning of the applied droop in a system utilizing primary side measurements
2. Tuning of the applied droop in a system utilizing primary side measurements, when the continuous and temporary voltage limits in FIKS are considered

The system considered was equal to the one shown in figure 22, and the measurements were taken from the primary side. In the first simulation the tuning should be done considering a voltage interval in which the voltage is most likely to vary for the actual system. Data given by Statkraft, based on measurements from mid October 2015 to mid April 2016, indicated that the voltage typically varied between 295-300 kV, where 298 kV is the desired value. The measurements also indicated that voltage variations between 290 kV and 305 kV occurred more seldom. For the first simulation it was therefore decided to vary the system voltage from 0.975 p.u. to 1.025 p.u. to consider the voltage variations from 290 kV to 305 kV, and tune the AVR's droop for this interval. In the last simulation, primary side measurements were utilized, and the continuous and temporary voltage limits in FIKS were considered. The limit for continuous operation is 280-300 kV, i.e. 0.93-1.00 p.u., while the temporary limit for periods shorter than 15 minutes is 270-315 kV, i.e. 0.90-1.05 p.u. For all simulations a strong grid was considered, and the components' ratings were as given in chapter 3.

8 Results

8.1 Investigating the Manner of Operation for the Current Control Strategy

8.1.1 Adjusting the Voltage Set Point for the Generators at the Exact Same Time as the System Voltage Changes

As mentioned in section 7.1, the purpose of doing this simulation was to illustrate how the current control system works. The power system consisted of two power stations, each having two generators connected to the same transformer. The measurements given to the AVRs were taken from the transformer's generator side. It was decided to do two simulations; one without any droop or compensation applied, and one with droops of 5% and 10% applied in Hove and Refsdal respectively, as in the actual system. When no droop or compensation was applied, an ideal system was considered, as droop should be included to ensure stable generator operation, when taking the measurements from the generators' terminals. For these simulations the system voltage was changed from 0.98 p.u. to 1.02 p.u., and the voltage set points for the power stations were adjusted according to the change in system voltage.

Figures 24 and 25 shows the responses in voltage and reactive power for the simulation where no droop or compensation was applied. Table 9 gives the values of voltage and reactive power for this simulation, and figure 26 shows the voltages at the primary and secondary side of the transformers in Hove and Refsdal, with respect to reactive power, when the generator set points and system voltage was changed. Table 10 and figure 27 gives the relation between voltage and reactive power when droop was applied. As the responses in voltage and reactive power was quite similar for the two cases, it was decided to only include the responses for the simulation without droop. The reactive powers Q_{G1} and $Q_{G1(1)}$, in tables 9 and 10, gives the reactive power generation for one machine in Hove and Refsdal respectively. The reactive powers in figure 26 and 27 are also given per machine. It should also be noticed that some of the voltage and reactive power curves in figures 24 and 25 overlap, due to equal measurement points and equal loading respectively.

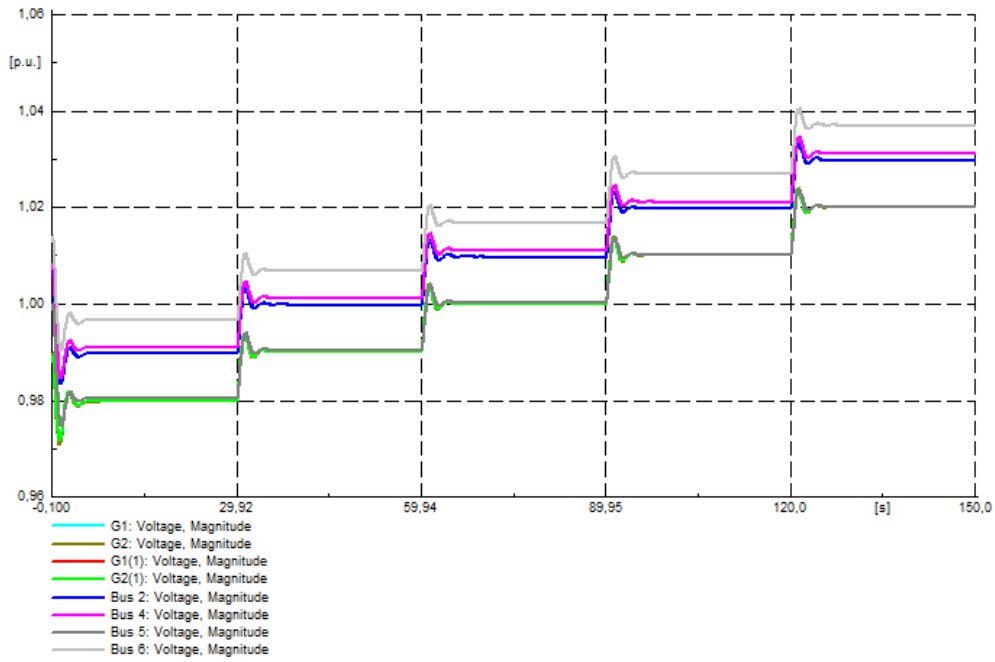

Figure 24: Voltage responses for the system when the voltage set points for the generators were changed at the exact same time as the system voltage changed

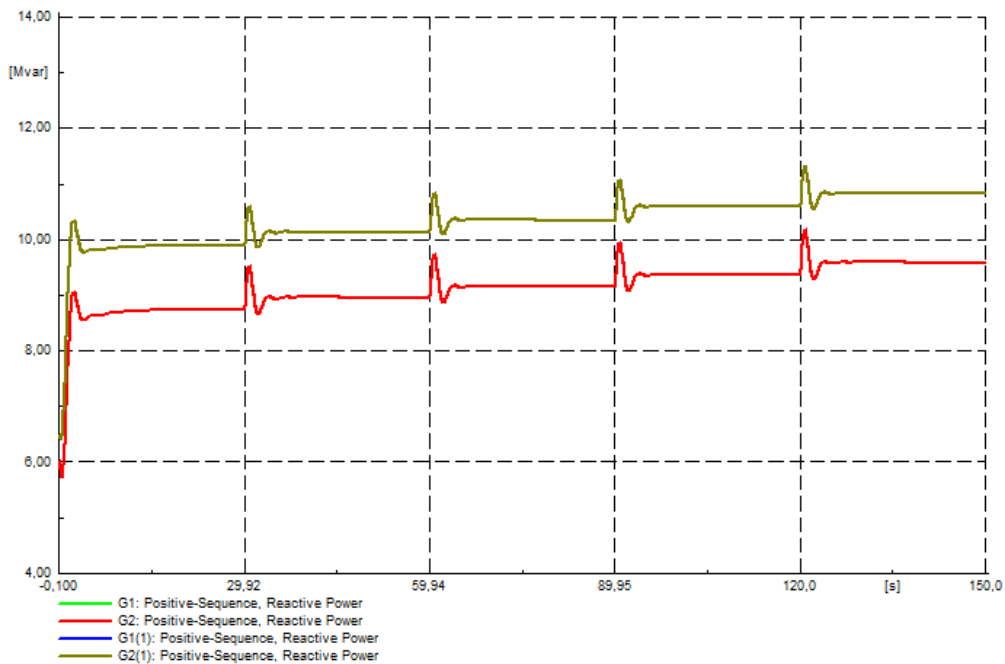

Figure 25: Responses in reactive power for the system when the voltage set points for the generators were changed at the exact same time as the system voltage changed

U_{setp} [p.u.]	V_{bus1} [p.u.]	V_{bus2} [p.u.]	Q_{G1} [MVar]	V_{bus3} [p.u.]	V_{bus4} [p.u.]	$Q_{G1(1)}$ [MVar]
0.980	0.980	0.990	8.747	0.980	0.991	9.891
0.990	0.990	1.000	8.953	0.990	1.001	10.118
1.000	1.000	1.010	9.162	1.000	1.011	10.348
1.010	1.010	1.020	9.373	1.010	1.021	10.582
1.020	1.020	1.030	9.587	1.020	1.031	10.819

Table 9: Q and V for the power stations when the voltage set points for the generators were changed at the exact same time as the system voltage changed

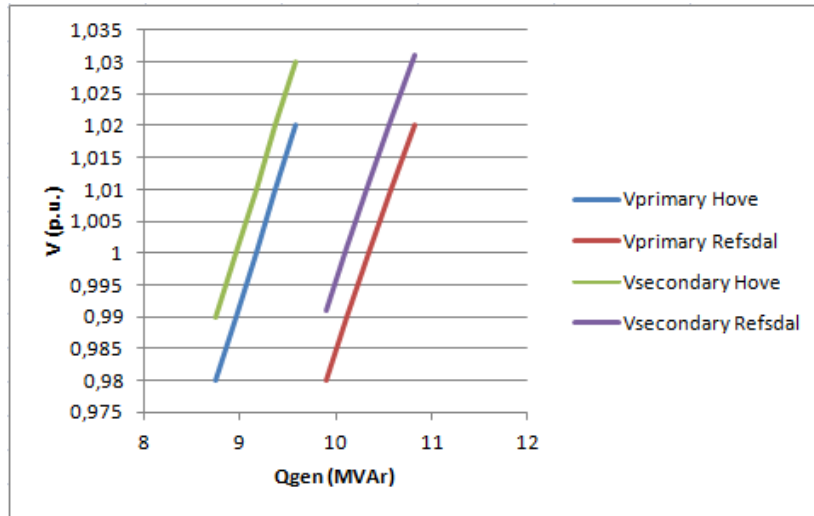

Figure 26: VQ-characteristics for the power stations when the voltage set points for the generators were changed at the exact same time as the system voltage changed

U_{setp} [p.u.]	V_{bus1} [p.u.]	V_{bus2} [p.u.]	Q_{G1} [MVar]	V_{bus3} [p.u.]	V_{bus4} [p.u.]	$Q_{G1(1)}$ [MVar]
0.980	0.977	0.989	7.960	0.976	0.990	8.576
0.990	0.987	0.999	8.102	0.986	1.000	8.712
1.000	0.997	1.009	8.243	0.996	1.010	8.849
1.010	1.007	1.019	8.386	1.006	1.020	8.986
1.020	1.016	1.029	8.530	1.015	1.030	9.124

Table 10: Q and V for the power stations when the voltage set points for the generators were changed at the exact same time as the system voltage changed, and droop was applied

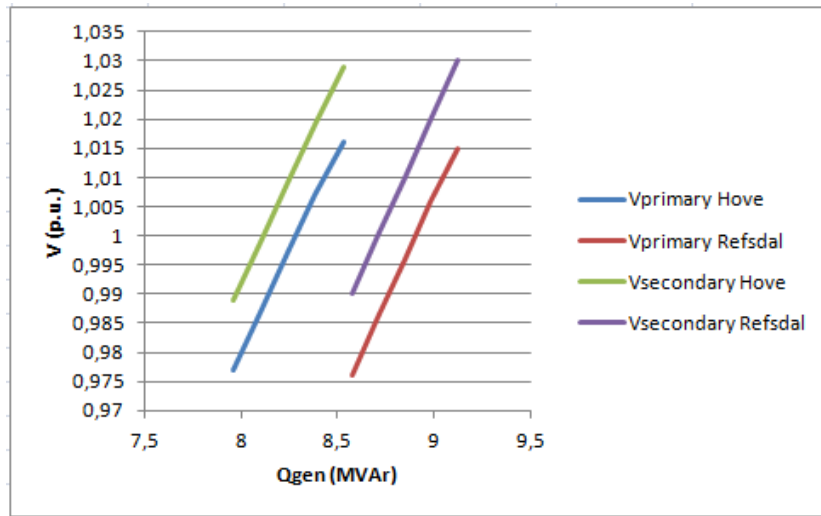

Figure 27: VQ-characteristics for the power stations when the voltage set points for the generators were changed at the exact same time as the system voltage changed, and droop was applied

8.1.2 Adjusting the Voltage Set Point for the Generators After the System Voltage Was Changed

For this simulation the system voltage was changed from 0.98 p.u. to 1.02 p.u. As for the previous simulation, the voltage set points in the power stations were adjusted according to the change in system voltage, but this adjustment was now performed some time after the change in system voltage occurred. This was done to see how the reactive power supply responded in the time between the system voltage change and the adjustment of set points. The system consisted of two power stations, each having two generators connected to the same transformer. The measurements given to the AVRs were taken from the transformer's generator side, and the AVRs had no droop or compensation applied. The purpose of doing this simulation was the same as for the simulations in section 8.1.1, i.e. to illustrate the manner of operation for the current control system. Figures 28 and 29 shows the responses in voltage and reactive power, and, as described in the previous section, some of the curves overlap. Table 11 gives the values of voltage and reactive power for this simulation. The reactive powers Q_{G1} and $Q_{G1(1)}$ gives the reactive power generation for one machine in Hove and Refsdal respectively.

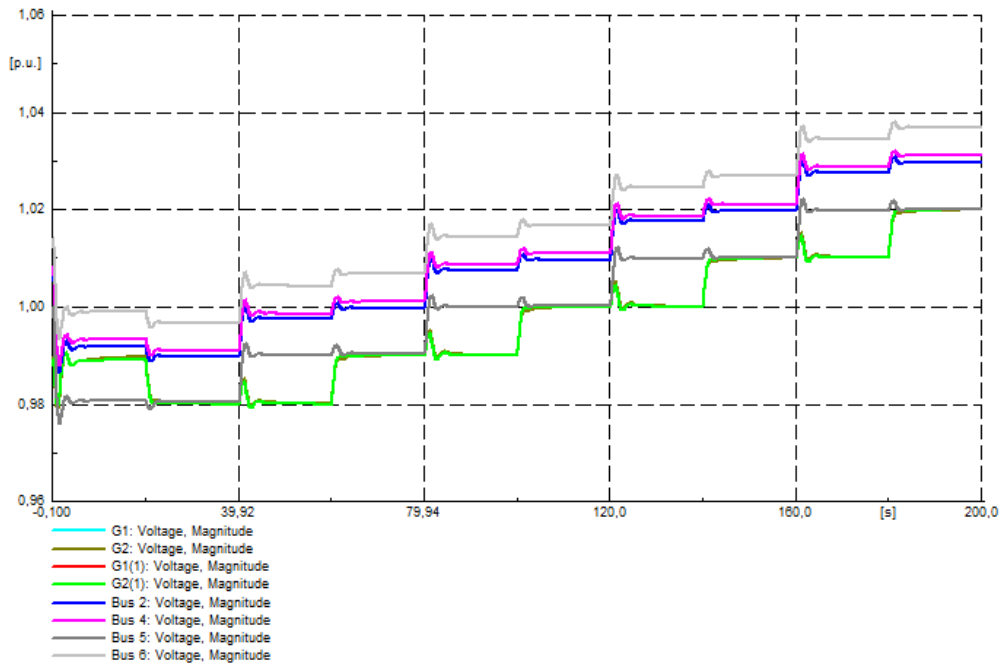

Figure 28: Voltage responses for the system when the voltage set points for the generators were changed after the system voltage was changed

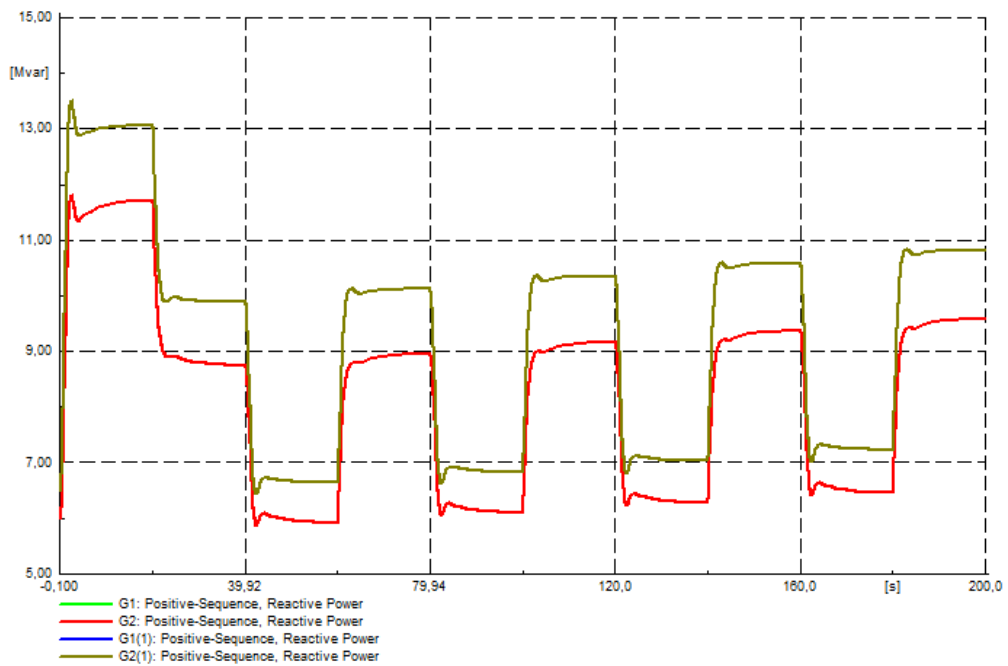

Figure 29: Responses in reactive power for the system when the voltage set points for the generators were changed after the system voltage was changed

U_{setp} [p.u.]	V_{bus1} [p.u.]	V_{bus2} [p.u.]	Q_{G1} [MVAR]	V_{bus3} [p.u.]	V_{bus4} [p.u.]	$Q_{G1(1)}$ [MVAR]
0.980	0.990	0.992	11.751	0.989	0.993	13.068
0.980	0.980	0.990	8.751	0.980	0.991	9.891
0.990	0.980	0.997	5.923	0.980	0.999	6.637
0.990	0.990	1.000	8.949	0.990	1.001	10.117
1.000	0.990	1.007	6.095	0.990	1.009	6.831
1.000	1.000	1.010	9.158	1.000	1.011	10.348
1.010	1.000	1.017	6.274	1.000	1.019	7.029
1.010	1.010	1.020	9.365	1.010	1.021	10.581
1.020	1.010	1.027	6.456	1.010	1.029	7.229
1.020	1.020	1.030	9.583	1.020	1.031	10.818

Table 11: Q and V for the power stations when the voltage set points for the generators were changed after the system voltage was changed

8.2 Investigating Droop and Compensation, When Considering Voltage Drop Across a Transformer

As mentioned in section 7.2, the purpose of doing the following simulations was just to investigate the voltages at the generators' terminals and the voltage drop across the transformers. Also, the effect of including droop and compensation was studied when considering the transformer's voltage drop.

8.2.1 Investigating Voltage Variations with Respect to Active and Reactive Power Supply

For this analysis the system with two power stations were considered, and the voltage at the generators' terminals and the voltage drop across the transformers were studied. In the different load flow analyses, system voltage, active power supply, and reactive power supply were varied. In the following figures the active power supply was set to 0%, 50% and 100% respectively, and the curves show how the voltage at the primary side, i.e. at the generator terminals, varied for increasing supply of reactive power. Also, three different system voltages were considered, that is 0.97 p.u., 1.00 p.u. and 1.03 p.u.. The figures below show the curves for the transformer in Hove power station. The curves for Refsdal power station are shown figures 73-75 in appendix A.2.1. In the figures the lower dots represented absorption of reactive power, whereas the upper dots represented large generation of reactive power.

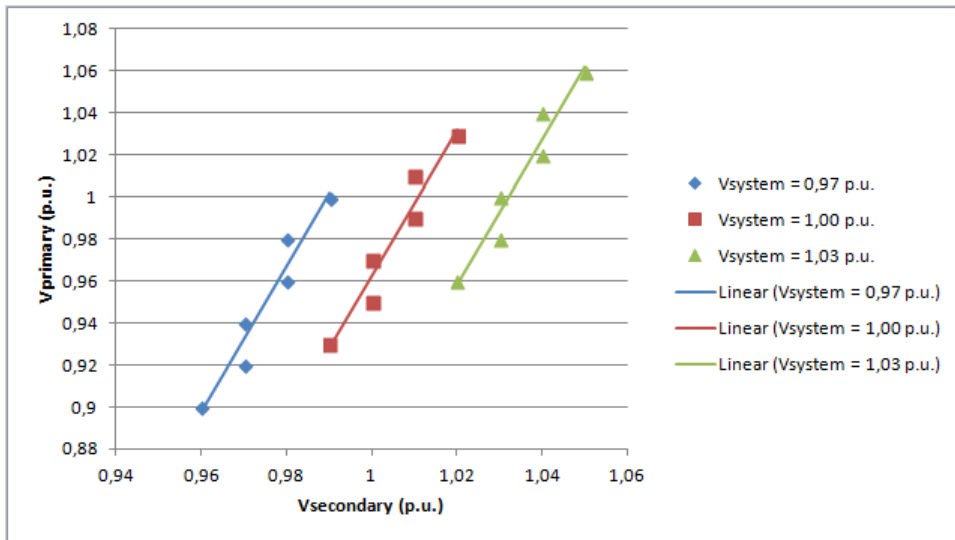

Figure 30: Voltage drop across the transformer in Hove when the generators are not delivering any active power

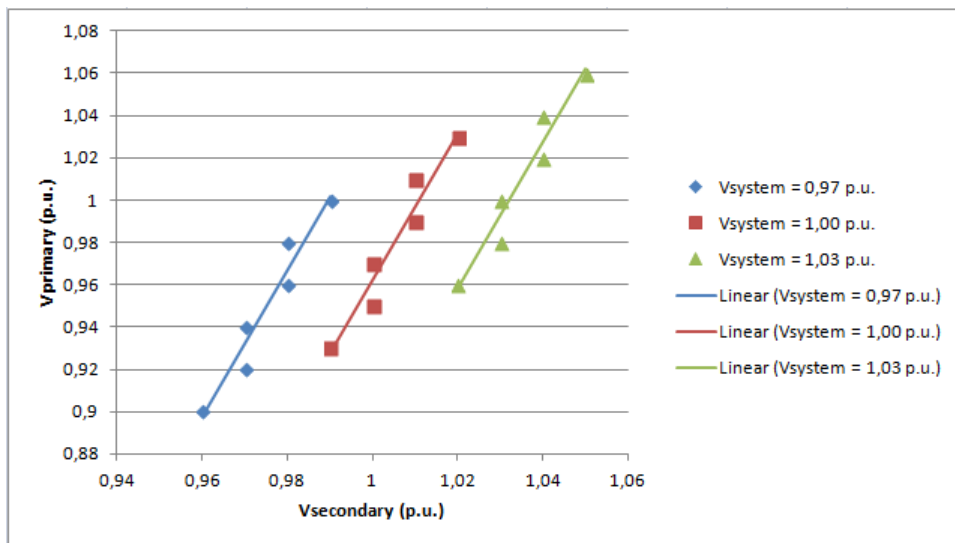

Figure 31: Voltage drop across the transformer in Hove when the generators are delivering 50% active power

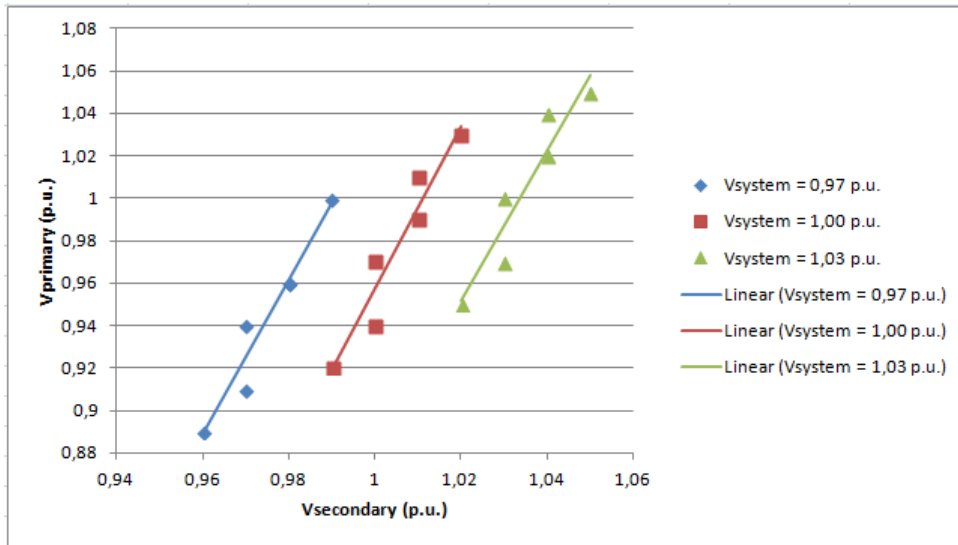

Figure 32: Voltage drop across the transformer in Hove when the generators are delivering 100% active power

8.2.2 Changing the System Voltage and Loading When There Is No Droop or Compensation Applied

For this simulation a model equal to the system showed in figure 23 was utilized, i.e. only one generator was considered. There was no droop or compensation applied in the generator's control system. The active power delivered from the generator was increased, and the system voltage was changed by adjusting the large synchronous machine's voltage set point from 0.90 p.u. to 1.10 p.u.. Figure 33 below shows how the voltages at the primary, generator side and secondary, grid side responded to the variations in voltage and loading.

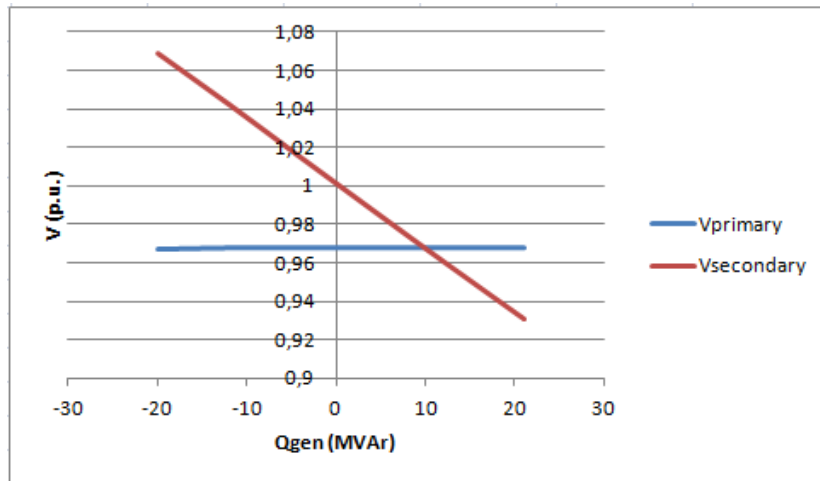

Figure 33: VQ-characteristic when no droop or compensation is applied

8.2.3 Changing the System Voltage and Loading When Compensation Is Applied

For this simulation only one generator was considered, and a compensation of 5% was applied in the generator's control system. As for the case in section 8.2.2, the active power delivered from the generator was increased, and the system voltage was changed by adjusting the large synchronous machine's voltage set point from 0.90 p.u. to 1.10 p.u.. Figure 34 shows how the voltages at the transformer's primary and secondary side responded when compensation was introduced.

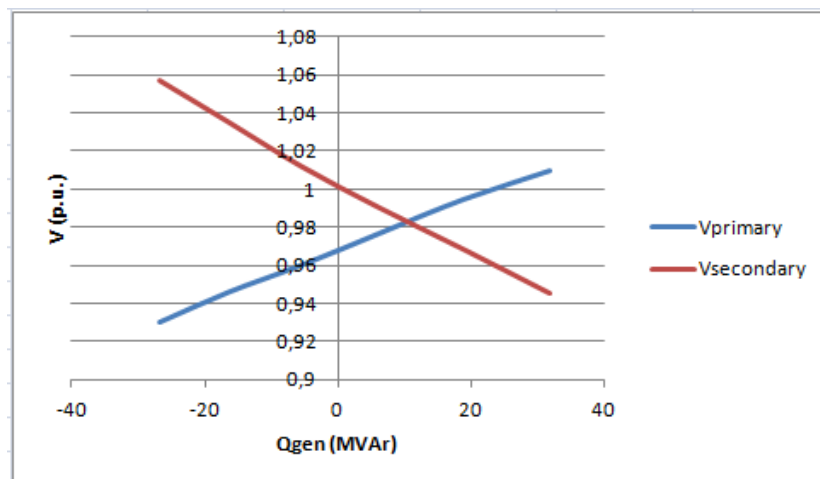

Figure 34: VQ-characteristic when compensation is applied

8.2.4 Changing the System Voltage and Loading When Droop Is Applied

As for the two previous simulations only one generator was considered, the loading of the generator was changed, and the system voltage was changed from 0.90 p.u. to 1.10 p.u.. In this case the generator's control system included a droop of 5%. Figure 35 below shows how the primary and secondary side voltage of the transformer responded to the inclusion of generator droop.

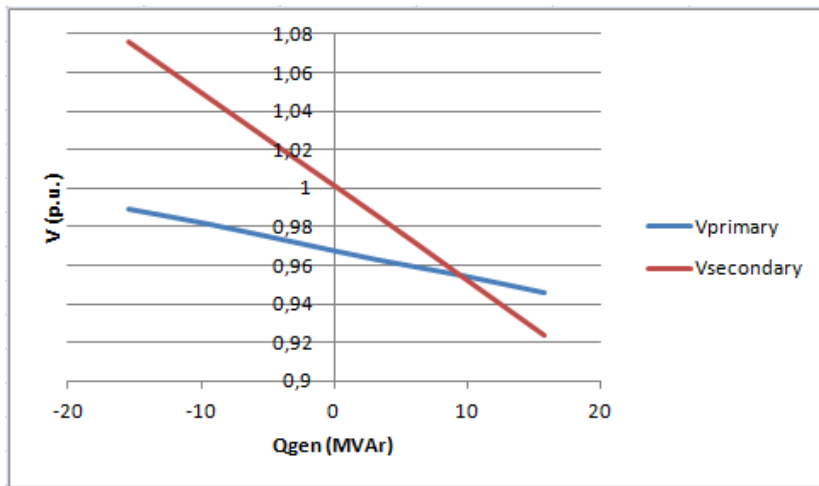

Figure 35: VQ-characteristic when droop is applied

8.3 Investigating the Effect of Droop and Compensation, When Taking the Measurements Given to the AVR from the Generators' Terminals

The purpose of doing the following simulations was to illustrate the fundamental effects of droop and compensation, when the measurements were taken from the primary side. Both single operated generators and parallel operated generators were considered. The following simulations were also done to be able to compare the effect of taking the measurements from the transformer's primary and secondary side. The results of the simulations investigating the effect of taking the measurements from the transformer's grid side, will be presented in section 8.4.

8.3.1 Changing the System Voltage When Compensation Is Studied for One Generator in Hove Power Station

In the following simulations only one generator in Hove power station was operated, while the other generators were disconnected. The purpose of doing these simulations was to investigate what impact the grid had on the generator, with respect to reactive power supply and voltage variations. Also, as mentioned in section 7.3, these simulations might indicate what contribution to voltage control the generator could provide.

For the first simulation compensation was applied in order to obtain a constant voltage at the transformer's grid side, when a weak grid drawing little reactive power was considered. The compensation was added by using the droop functionality implemented for the AVR as described in section 6.2. The transformer's reactance referred to the generator rating was taken into account, according to equation 26 in section 6.2, before it was given to the droop functionality. The system voltage was changed by adjusting the large synchronous machine's voltage set point from 0.98 p.u. to 1.02 p.u., and consequently the reactive power supply from the generator in Hove was changed. Table 12 below gives the voltages and reactive powers when trying to attain a constant voltage at the grid side, when a weak grid is considered.

U_{setp} [p.u.]	$V_{primary}$ [p.u.]	$V_{secondary}$ [p.u.]	Q_{G1} [MVAR]
0.98	1.002	1.009	19.869
0.99	0.995	1.010	13.383
1.00	0.985	1.010	6.262
1.01	0.976	1.010	-0.679
1.02	0.967	1.010	-7.468

Table 12: Q and V for a generator in Hove connected to a weaker grid, when the measurements are taken from the transformer's primary side

The simulation results presented in the table above, indicated that the generator in Hove did not manage to obtain a constant secondary side voltage without experiencing exceeded excitation limits. Table 13 below gives the values for voltage and reactive power for this generator, when the applied compensation was reduced to comply with the excitation limits. Figure 38 shows the relation between voltage and reactive power for this simulation. The responses in voltage and reactive power when considering this case are shown in figures 36 and 37.

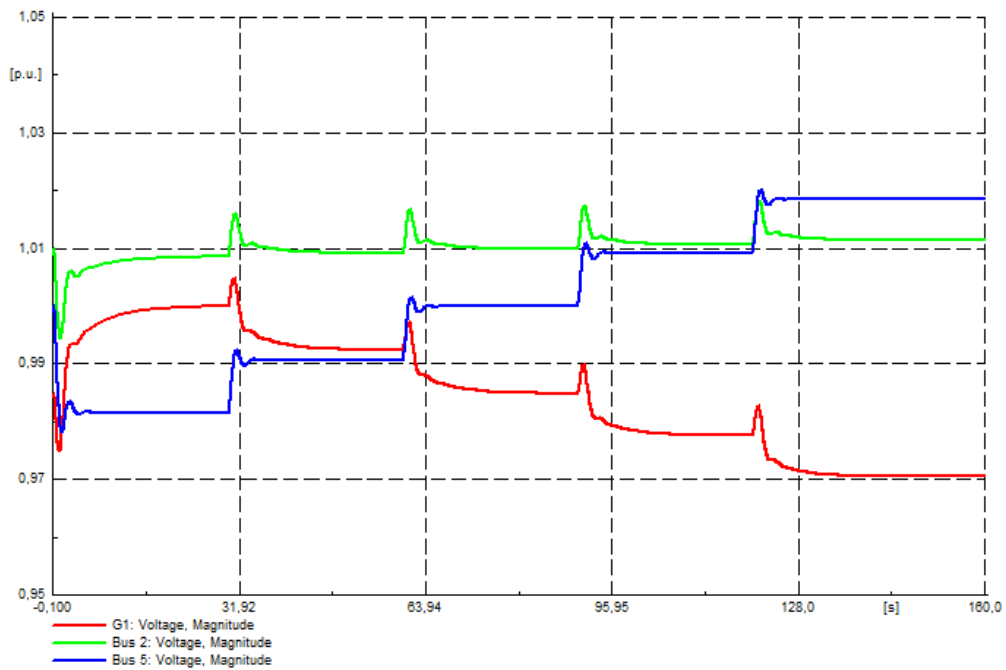

Figure 36: Voltage responses for a weak grid when primary side measurements are utilized, and only one generator in Hove is considered

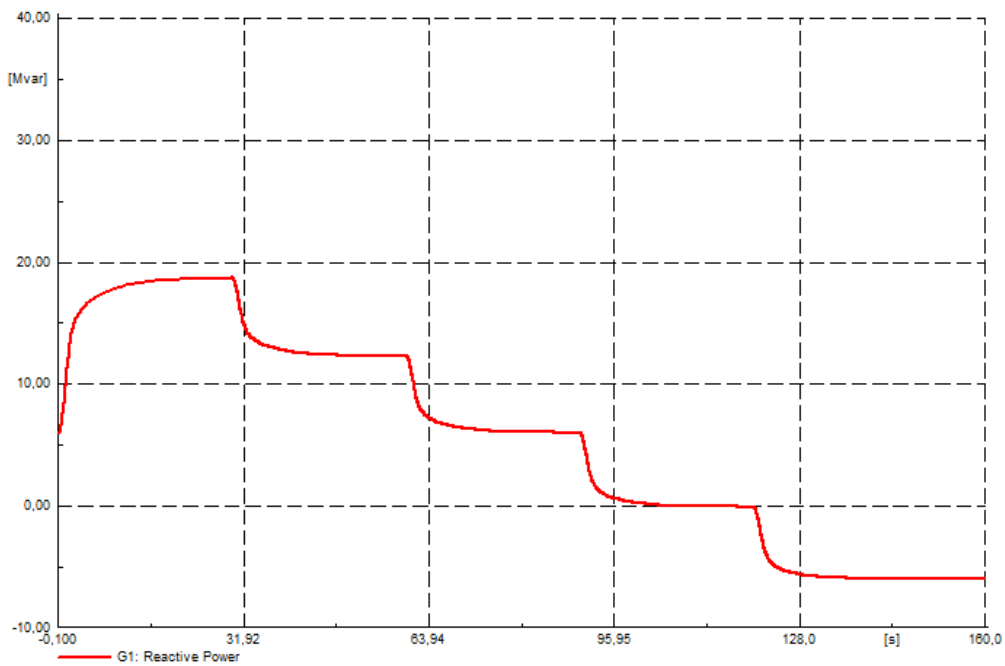

Figure 37: Response in reactive power for a weak grid when primary side measurements are utilized, and only one generator in Hove is considered

U_{setp} [p.u.]	$V_{primary}$ [p.u.]	$V_{secondary}$ [p.u.]	Q_{G1} [MVar]
0.98	1.000	1.009	18.656
0.99	0.992	1.009	12.262
1.00	0.985	1.010	6.008
1.01	0.978	1.011	-0.079
1.02	0.970	1.011	-6.015

Table 13: Q and V for a generator in Hove connected to a weaker grid when a smaller compensation is applied, and the measurements are taken from the transformer's primary side

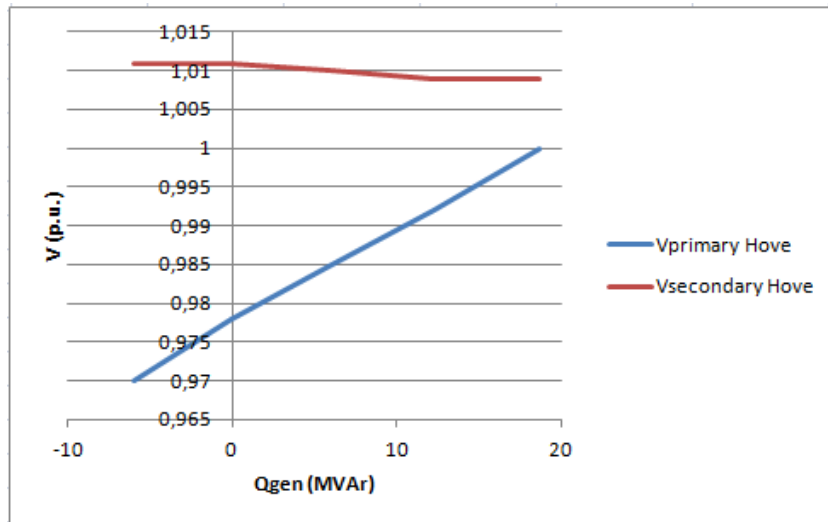

Figure 38: VQ-characteristic for a generator in Hove when a weaker grid is considered, and the measurements are taken from the transformer's primary side

In addition it was decided to investigate the generator's behaviour when connected to a strong grid drawing more reactive power, to see what compensation the generator was capable of delivering then. The responses in voltage and reactive power are shown in figures 39 and 40. The measurements of voltage and reactive power for this case are given in table 14, and the relation between voltage and reactive power is given in figure 41.

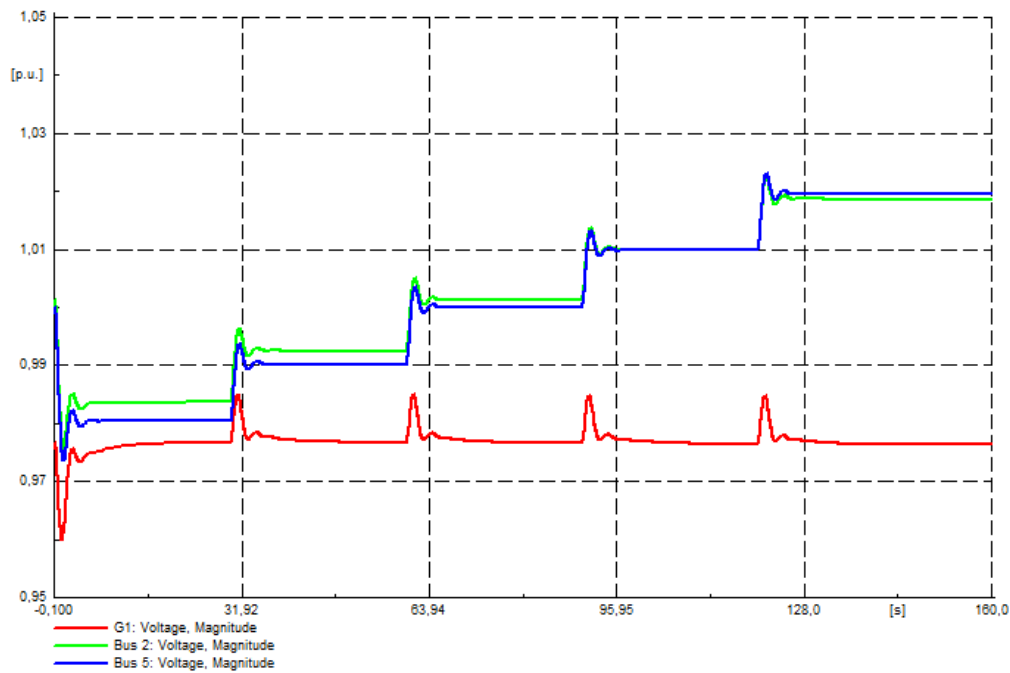

Figure 39: Voltage responses for a strong grid when primary side measurements are utilized, and only one generator in Hove is considered

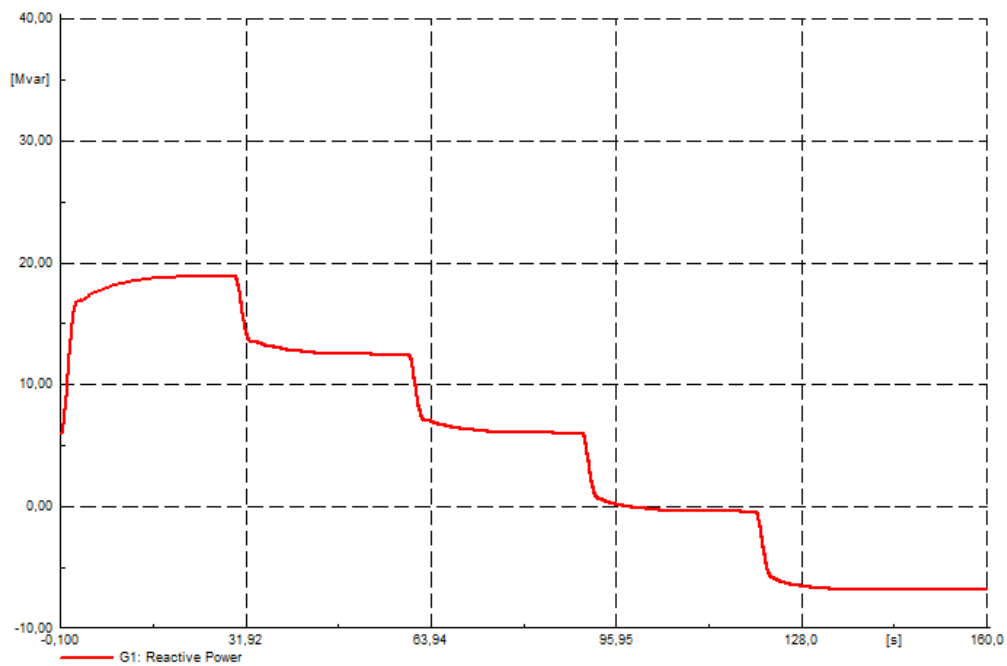

Figure 40: Response in reactive power for a strong grid when primary side measurements are utilized, and only one generator in Hove is considered

U_{setp} [p.u.]	$V_{primary}$ [p.u.]	$V_{secondary}$ [p.u.]	Q_{G1} [MVar]
0.98	0.977	0.984	18.881
0.99	0.977	0.992	12.451
1.00	0.977	1.001	6.007
1.01	0.977	1.010	-0.455
1.02	0.976	1.019	-6.891

Table 14: Q and V for a generator in Hove connected to a strong grid, when the measurements are taken from the transformer's primary side

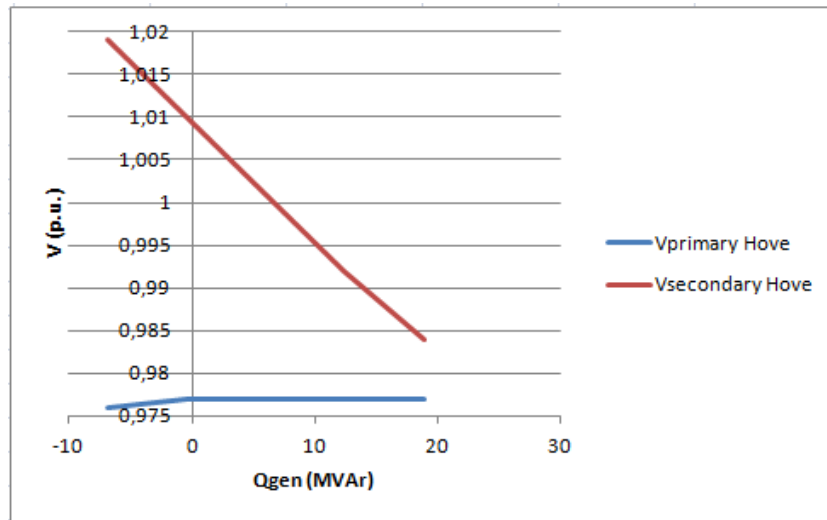

Figure 41: VQ-characteristic for a generator in Hove when a strong grid is considered, and the measurements are taken from the transformer's primary side

8.3.2 Changing the System Voltage When No Droop Is Applied

For the simulations considered in this section, the system voltage was changed from 0.98 p.u. to 1.02 p.u.. The system consisted of two power stations, each having two generators connected to a common transformer, and the measurements given to the AVRs were taken from the transformer's primary side. The AVRs droop settings were adjusted such that the effect of applying neither droop nor compensation, and the effect of applying compensation, could be studied.

When no droop or compensation was applied, the voltage at the generators' terminals were consequently kept constant when considering ideal operating conditions. Under these conditions the loading of the paralleled generators, and the tuning of

their AVRs, were identical. The resulting VQ-characteristics for this simulation, increasing the voltage from 0.98 p.u. to 1.02 p.u., are given in figure 42 below. It should be mentioned that the reactive powers in the figure are given per machine.

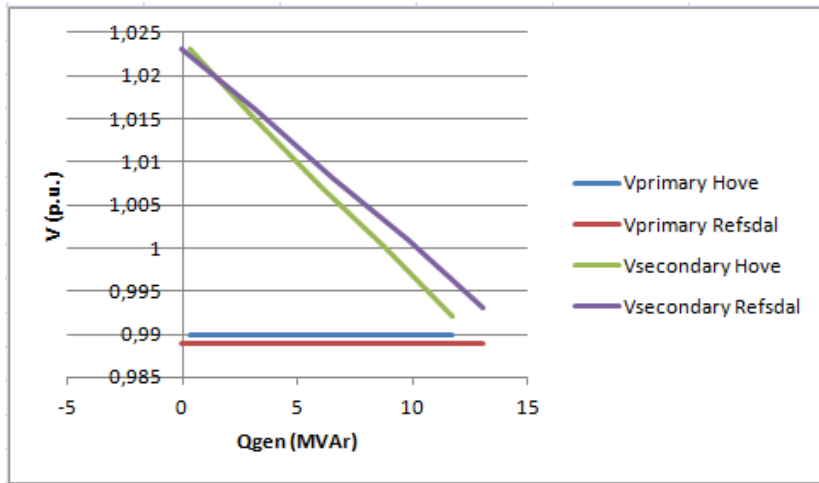

Figure 42: VQ-characteristics when the measurements are taken from the transformer's primary side, and no droop or compensation is applied

When the effect of compensation was to be studied, a net compensation of 3% were applied at the generators. The relation between voltage and reactive power for the power stations, when considering ideal operating conditions, are shown in figure 43 below.

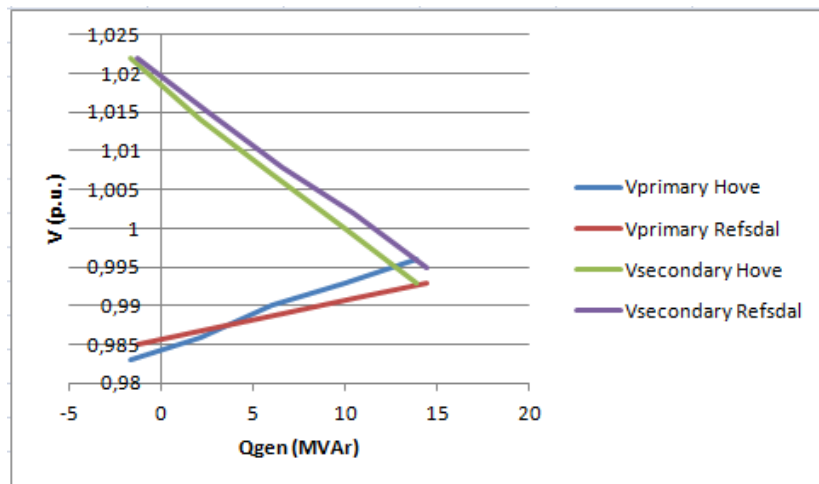

Figure 43: VQ-characteristics when the measurements are taken from the transformer's primary side, and compensation is applied

The simulations presented above considered ideal cases, with identical operation of the paralleled generators and equal AVR settings. For the actual operation, ideal and identical operating conditions can not be assumed. To investigate how the power system responded to the compensation under unideal conditions, it was therefore decided to perform a new simulation changing the voltage set point of one of the paralleled generators in Hove, G1. The system now became unstable. This was an expected result based on the findings in the specialization project, which stated that droop was needed in order to ensure stable generator operation, when operating paralleled generators and utilizing primary side measurements. The responses in reactive power for the power stations then became as shown in figure 44. A similar response was also obtained when neither droop nor compensation was applied.

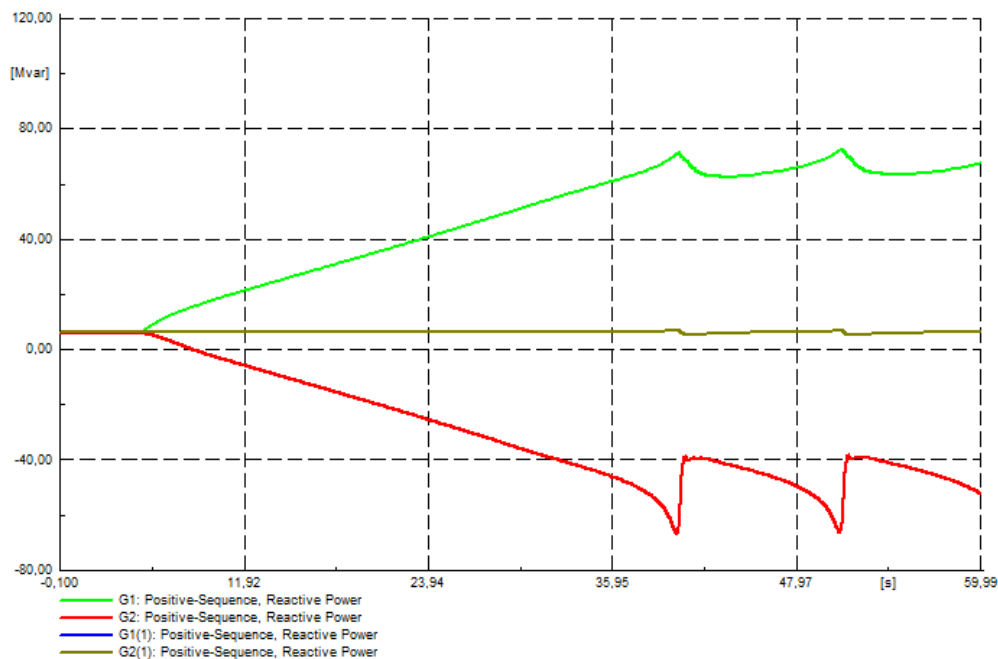

Figure 44: Unstable responses in reactive power when no droop is applied, and unideal operating conditions are considered

8.3.3 Changing the System Voltage When Droop Is Applied

As for the previous simulation, the system consisted of two power stations, each having two paralleled generators, and the AVRs got their inputs from the primary side. The system voltage was changed from 0.98 p.u. to 1.02 p.u.. The power stations now had droop functionalities included, and the droop applied was of 5%

and 10% in Hove and Refsdal respectively. Figure 45 below shows the voltages with respect to reactive power when the system voltage was changed. Table 15 gives the values for voltage and reactive power for the power stations. As for section 8.3.2, it should be mentioned that the reactive power is given for one machine.

U_{setp} [p.u.]	V_{bus1} [p.u.]	V_{bus2} [p.u.]	Q_{G1} [MVA _r]	V_{bus3} [p.u.]	V_{bus4} [p.u.]	$Q_{G1(1)}$ [MVA _r]
0.98	0.984	0.990	10.053	0.982	0.992	10.526
0.99	0.987	0.999	8.031	0.986	1.000	8.157
1.00	0.990	1.007	6.000	0.989	1.008	6.500
1.01	0.992	1.016	3.961	0.993	1.017	4.474
1.02	0.995	1.024	1.914	0.996	1.025	2.439

Table 15: Q and V for the power stations when the measurements are taken from the transformer’s primary side, and droop is applied

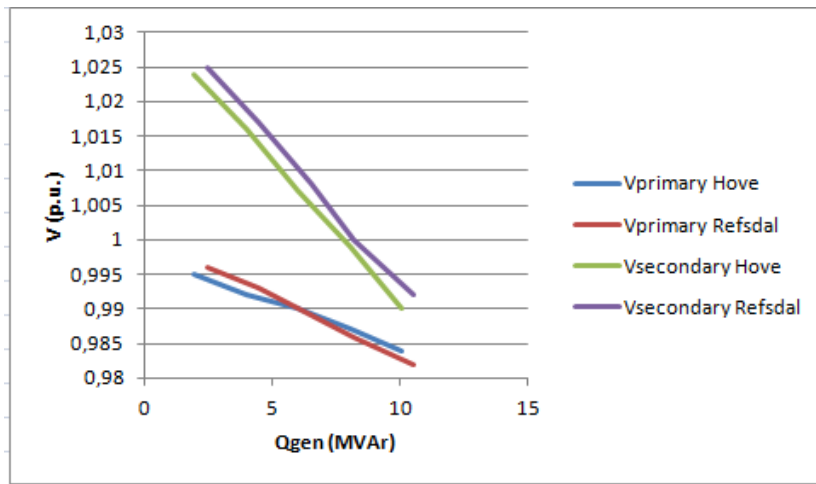

Figure 45: VQ-characteristics for the power stations when the measurements are taken from the transformer’s primary side, and droop is applied

The system should also be tested for an unideal operating condition, and hence the voltage set point of generator $G1$ in Hove power station was changed. The system remained stable. The responses in voltage and reactive power are shown in figures 46 and 47 below.

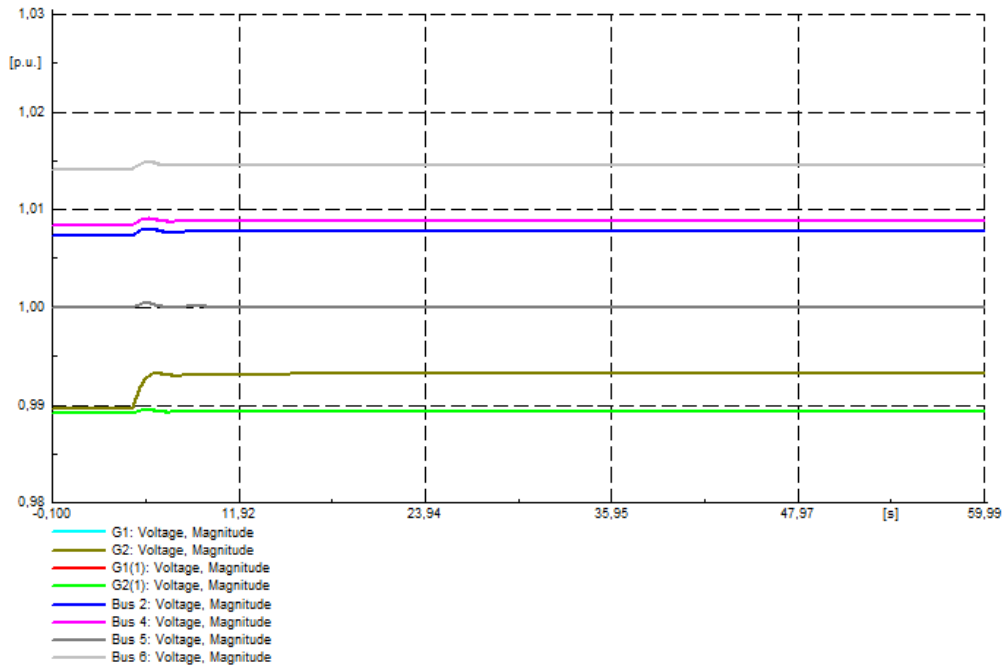

Figure 46: Stable voltage responses when droop is applied, and unideal operating conditions are considered

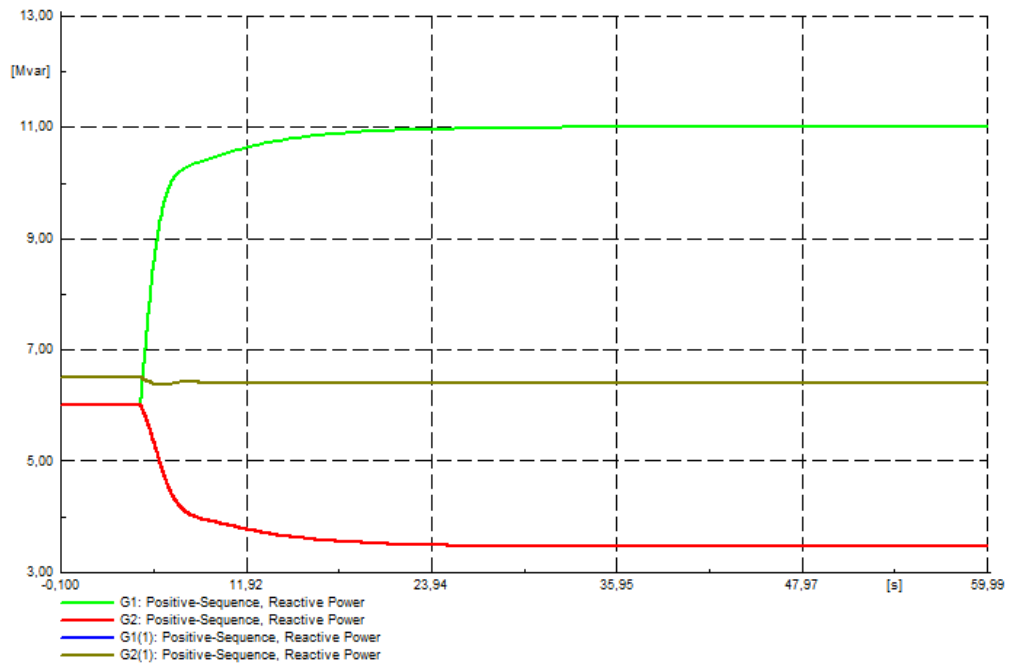

Figure 47: Stable responses in reactive power when droop is applied, and unideal operating conditions are considered

8.4 Investigating the Effect of Droop and Compensation, When Taking the Measurements Given to the AVR from the Transformer's Secondary Side

It was decided to do simulations to investigate the effect of moving the measuring points to the transformer's grid side, or secondary side, as this might improve the control of generators that are connected to a common transformer. Also, the effect of utilizing secondary side measurements was studied for the case where only one generator was operating, to see if there were differences compared to the case utilizing of measurements from the generators' terminals. The effect of moving the measurements from the primary to the secondary side, was studied by utilizing a functionality that made it possible to estimate the voltage at the transformer's secondary side. This functionality was described in section 6.2. By utilizing this functionality, the voltage drop across the transformer was therefore taken into account. It was decided to first study the effect of compensation when only one generator was operating. Further the effect of droop and compensation was studied for the whole system.

8.4.1 Changing the System Voltage When Compensation Is Studied for One Generator in Hove Power Station

In the following simulations only one generator in Hove power station was operated. The other machines in the power stations were disconnected. The aim of the simulations, presented in this section, was to investigate the voltage drop across the transformer, and the effects of taking the measurements from the secondary side, when one generator was operating alone. The system voltage was changed from 0.98 p.u. to 1.02 p.u.. In order to adjust the compensation provided by the AVR for the different cases, the reactance in the estimation function was changed.

The first simulation investigated the voltage drop across the transformer when the generator was connected to a weak grid drawing little reactive power. I.e., the large synchronous machine's rating was reduced to 200 MVA, and the load was adjusted to draw 50 MW and 50 MVar. In addition, the line length between the generator and the grid was increased to 300 km. The responses in voltage and reactive power are shown in figures 48 and 48 below. Table 16 shows values for voltage and reactive power, and figure 50 shows the relation between voltage and reactive power.

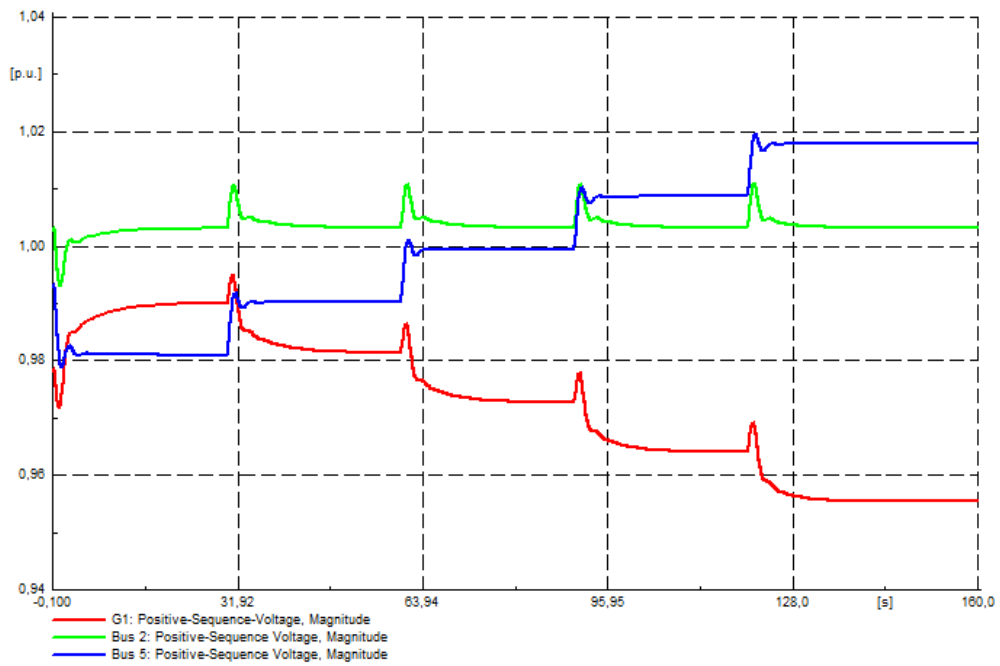

Figure 48: Voltage responses for a weak grid when secondary side measurements are utilized, and only one generator in Hove is considered

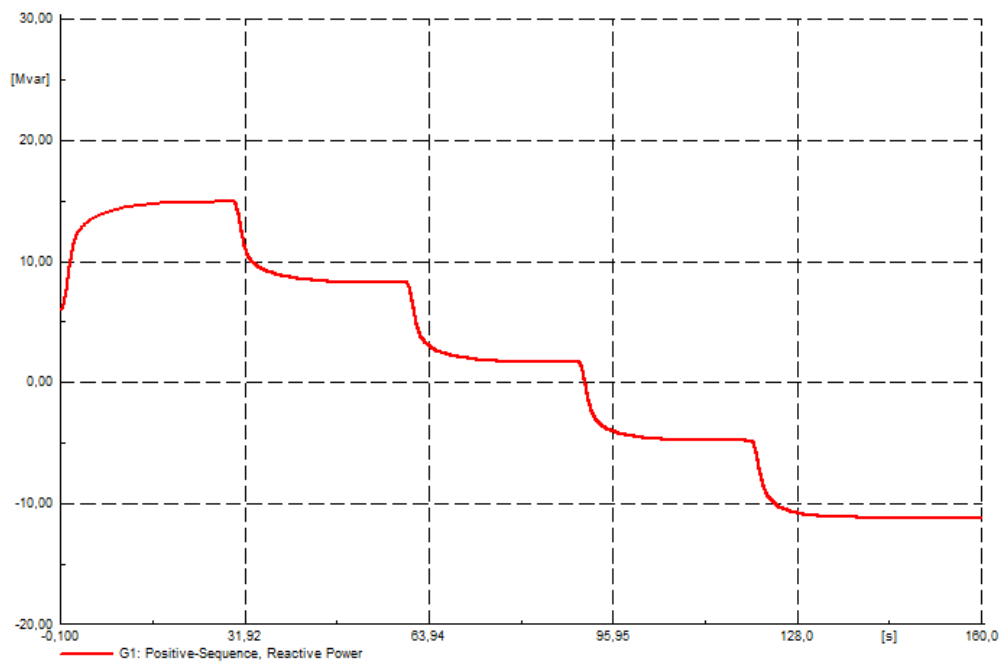

Figure 49: Response in reactive power for a weak grid when secondary side measurements are utilized, and only one generator in Hove is considered

U_{setp} [p.u.]	$V_{primary}$ [p.u.]	$V_{secondary}$ [p.u.]	Q_{G1} [MVA _r]
0.98	0.990	1.003	14.897
0.99	0.981	1.003	8.220
1.00	0.973	1.003	1.631
1.01	0.964	1.003	-4.839
1.02	0.955	1.003	-11.199

Table 16: Q and V for a generator in Hove connected to a weaker grid, when the measurements are taken from the transformer's secondary side

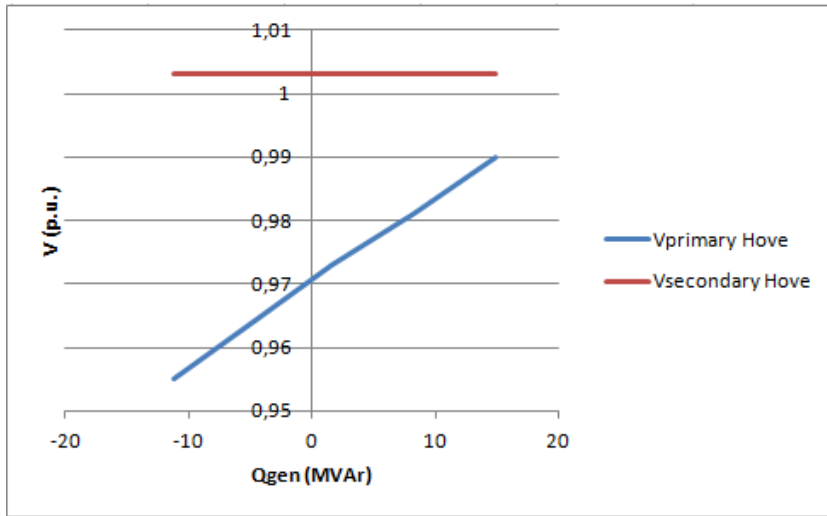

Figure 50: VQ-characteristic for a generator in Hove when a weaker grid is considered, and the measurements are taken from the transformer's secondary side

The second simulation also investigated the voltage drop, but now the generator was connected to a strong grid drawing more reactive power, with a generator in the production area having a rating of 1000 MVA. The measurements given to the AVRs were taken from the transformer's secondary side. The responses in voltage and reactive power are shown in figures 51 and 52. Figure 53 shows the voltages at the transformer's primary and secondary side, with respect to reactive power generation, and is based on the values presented in table 17.

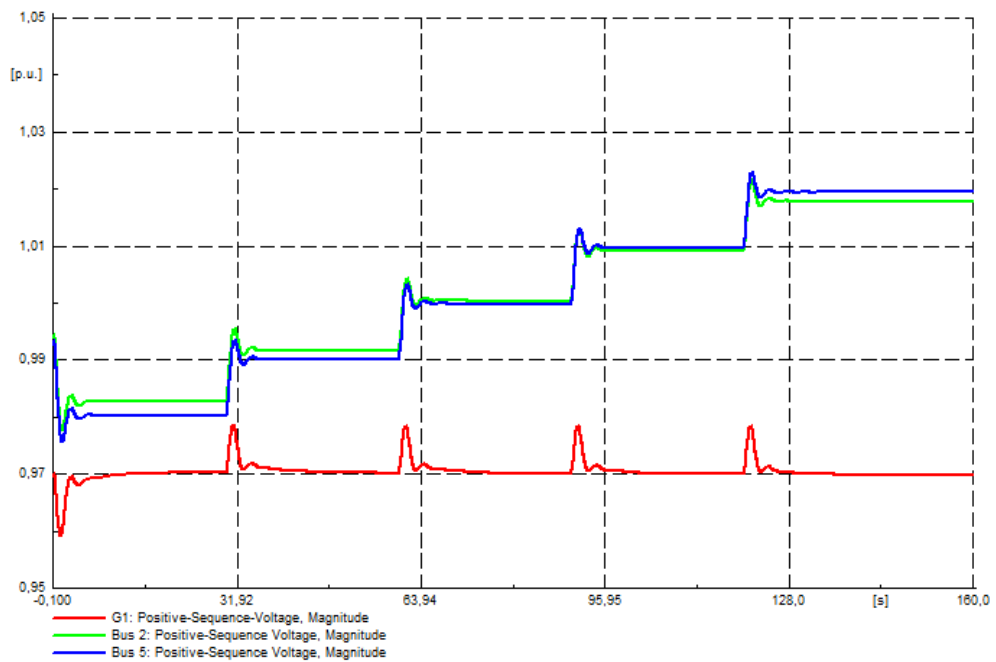

Figure 51: Voltage responses for a strong grid when secondary side measurements are utilized, and only one generator in Hove is considered

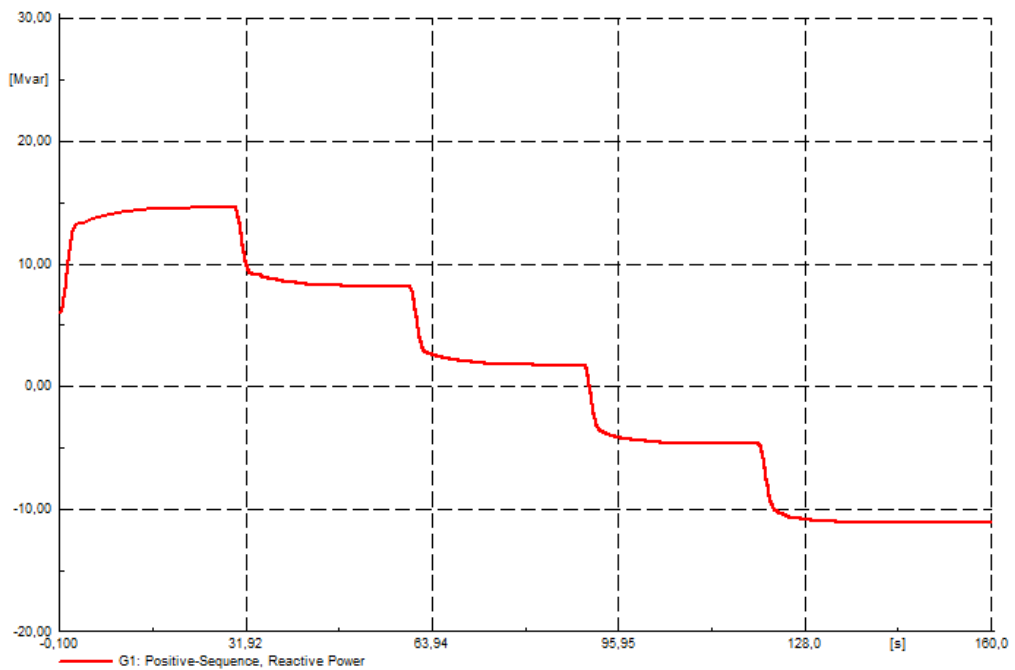

Figure 52: Response in reactive power for a strong grid when secondary side measurements are utilized, and only one generator in Hove is considered

U_{setp} [p.u.]	$V_{primary}$ [p.u.]	$V_{secondary}$ [p.u.]	Q_{G1} [MVA _r]
0.98	0.970	0.983	14.557
0.99	0.970	0.992	8.148
1.00	0.970	1.000	1.725
1.01	0.970	1.009	-4.698
1.02	0.970	1.018	-11.122

Table 17: Q and V for a generator in Hove connected to a strong grid, when the measurements are taken from the transformer's secondary side

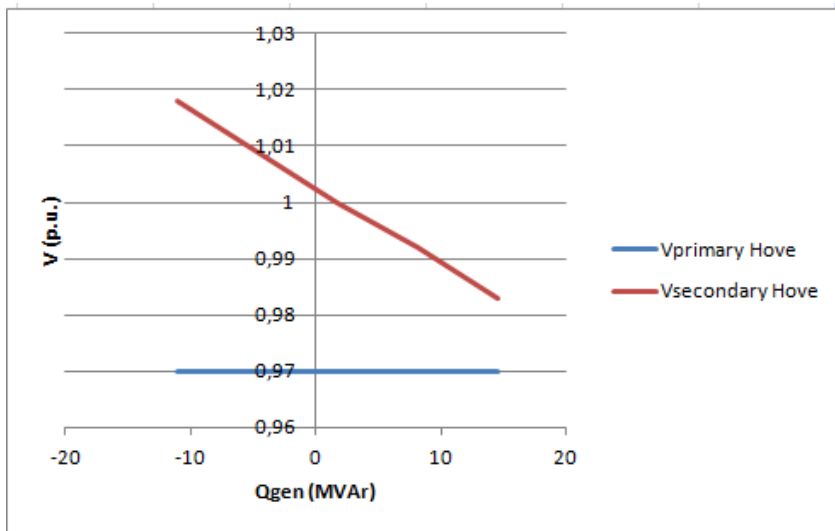

Figure 53: VQ-characteristic for a generator in Hove when a strong grid is considered, and the measurements are taken from the transformer's secondary side

The last simulation, studying a single generator in Hove power station connected to a strong grid, illustrated the system's behaviour when the compensation was too large. Voltage responses, and the response in reactive power generation, are shown in figures 54 and 55 respectively.

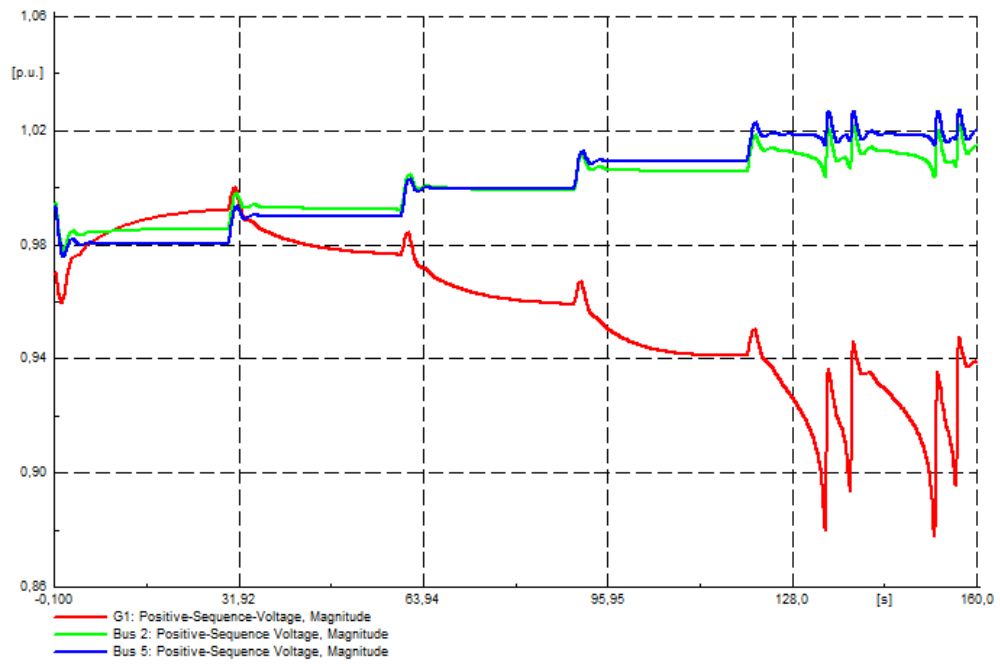

Figure 54: Unstable voltage responses when a large compensation is applied, and the measurements are taken from the transformer’s secondary side

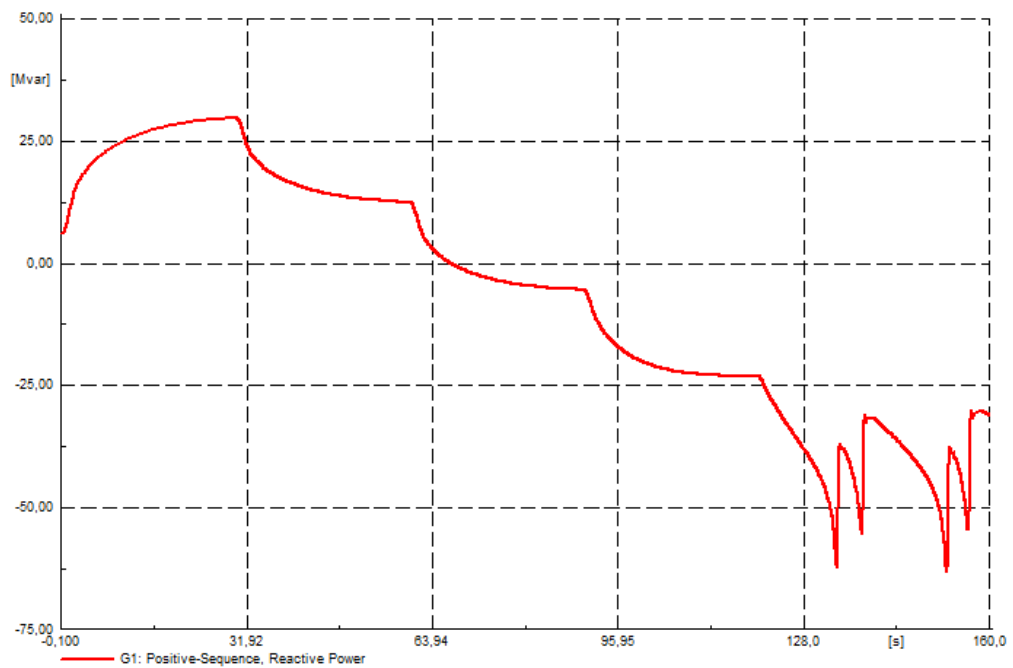

Figure 55: Unstable response in reactive power when a large compensation is applied, and the measurements are taken from the transformer’s secondary side

8.4.2 Changing the System Voltage When No Droop Is Applied

For the simulations considered in this section, the system voltage was changed from 0.98 p.u. to 1.02 p.u.. The system consisted of two power stations, each having two paralleled generators. The measurements were taken from the transformer's secondary side, and given to the AVRs by the estimation function described in section 6.2. The droop settings were adjusted such that the effect of applying neither droop nor compensation, and the effect of applying compensation, could be studied.

When no droop or compensation was applied, and the system voltage was changed, the system became unstable. This instability occurred for a system with ideal operating conditions. Instability also occurred when a net additional compensation of 3% was applied at the generators, but now the system became unstable at an earlier stage. The unstable responses in voltage and reactive power, when no droop or compensation was applied, are shown in figures 56 and 57.

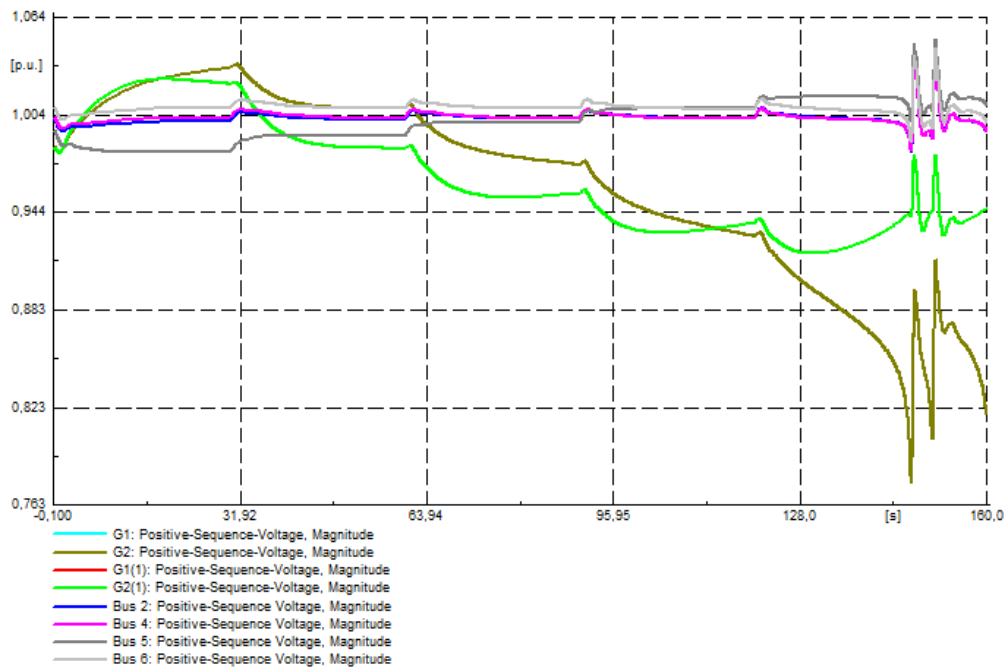

Figure 56: Unstable voltage responses when no droop or compensation is applied, and the measurements are taken from the transformer's secondary side

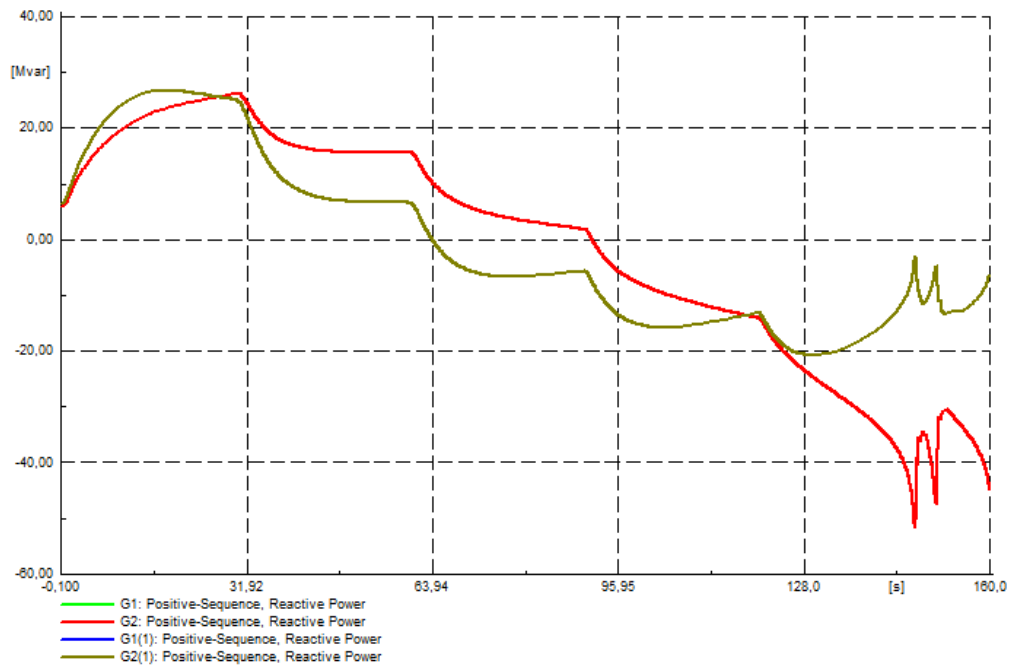

Figure 57: Unstable responses in reactive power when no droop or compensation is applied, and the measurements are taken from the transformer’s secondary side

8.4.3 Changing the System Voltage When Droop Is Applied

In this simulation the system voltage was changed from 0.98 p.u. to 1.02 p.u., as in the previous section. The system still consisted of two power stations, each having two paralleled generators. The measurements given to the AVRs were taken from the transformer’s secondary side, and a droop of 5% and 10% was applied for the AVRs in Hove and Refsdal respectively. I.e., the droop was defined in the estimation function. This means that there was still a net compensation at the transformers’ primary side, as the droop applied was less than the compensation for the transformer reactance. Figures 58 and 59 shows the responses in voltage and reactive power, when the system voltage was changed for ideal operating conditions. The resulting relation between voltage and reactive power is shown in figure 60, that is based on the values in table 18 below.

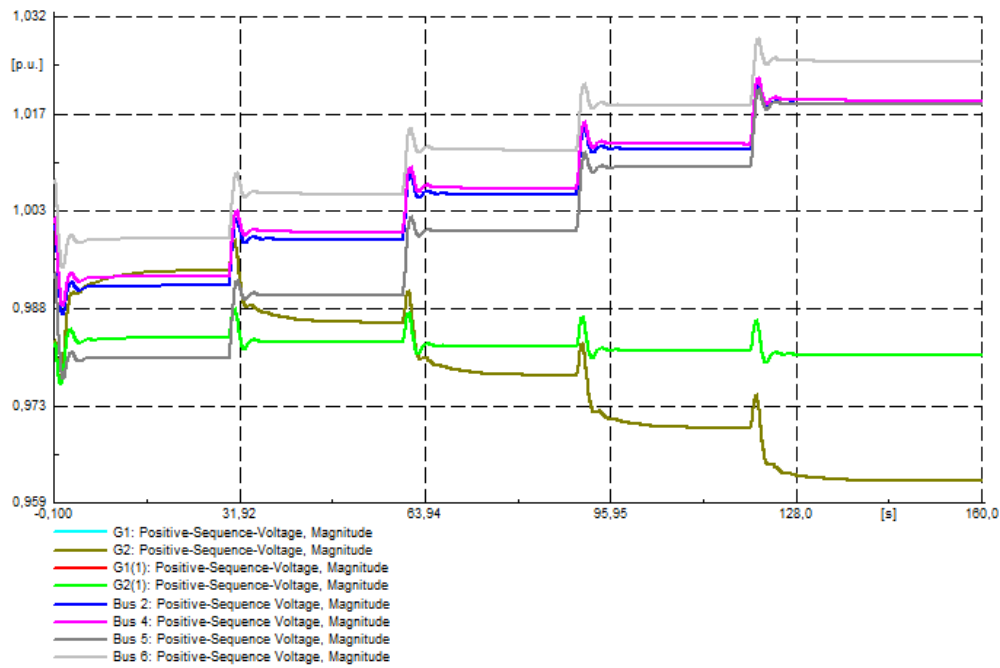

Figure 58: Voltage responses when droop is applied, and the measurements are taken from the transformer's secondary side

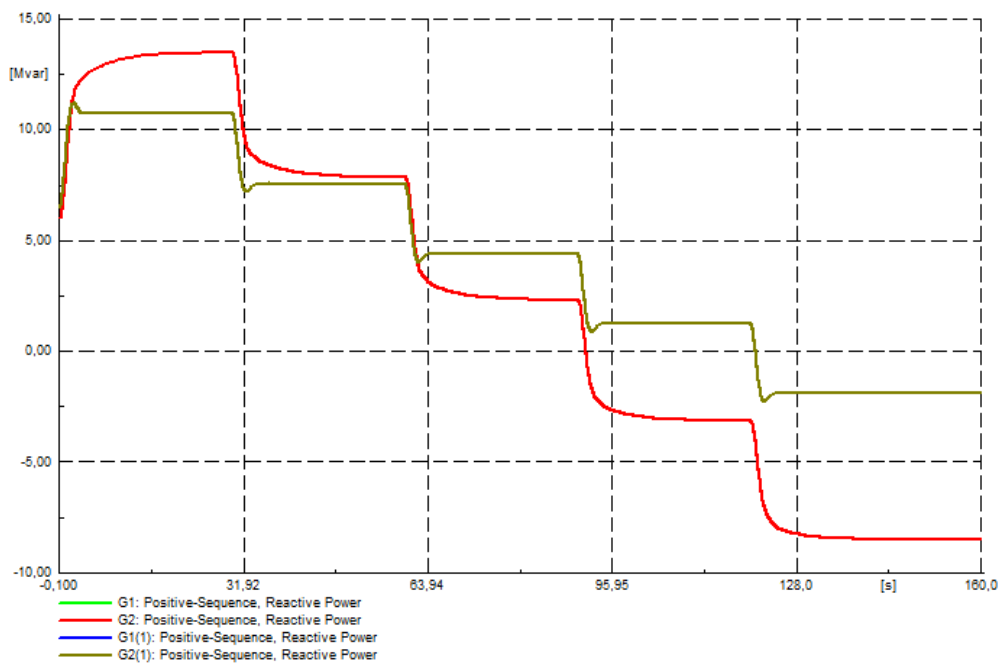

Figure 59: Responses in reactive power when droop is applied, and the measurements are taken from the transformer's secondary side

U_{setp} [p.u.]	V_{bus1} [p.u.]	V_{bus2} [p.u.]	Q_{G1} [MVar]	V_{bus3} [p.u.]	V_{bus4} [p.u.]	$Q_{G1(1)}$ [MVar]
0.98	0.994	0.992	13.473	0.984	0.993	10.683
0.99	0.986	0.998	7.853	0.983	1.000	7.554
1.00	0.978	1.005	2.354	0.982	1.006	4.421
1.01	0.970	1.012	-3.018	0.982	1.013	1.327
1.02	0.962	1.019	-8.270	0.981	1.019	-1.742

Table 18: Q and V for the power stations when the measurements are taken from the transformer's secondary side, and droop is applied at the generators

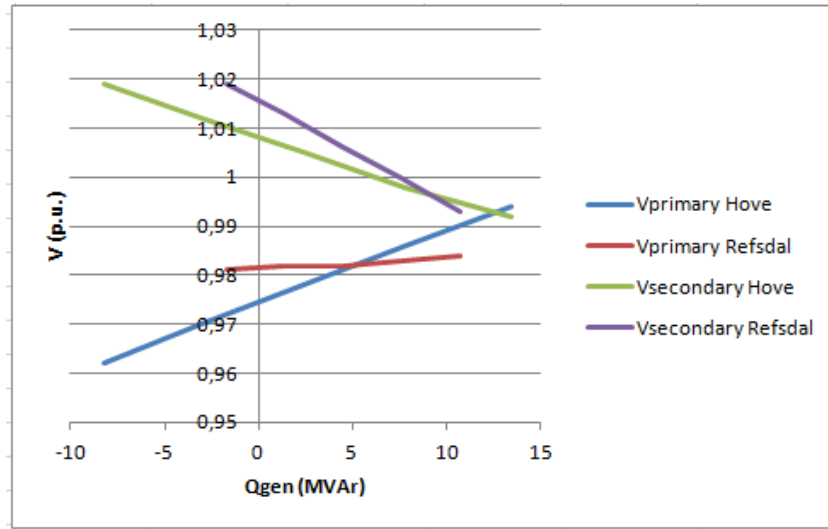

Figure 60: VQ-characteristics for the power stations when the measurements are taken from the transformer's secondary side, and droop is applied at the generators

As the inclusion of 5% and 10% droop at the generators still gave a net compensation at the transformers' primary side, it was decided to test the system behaviour when increasing the reactive droop. The droop was increased such that the resulting droop at the transformers' primary side became 5% and 10% in Hove and Refsdal respectively. The responses in voltage and reactive power for this case are shown in figures 61 and 62. The values for voltage and reactive power are given in table 19, while the resulting VQ-characteristic are shown in figure 63.

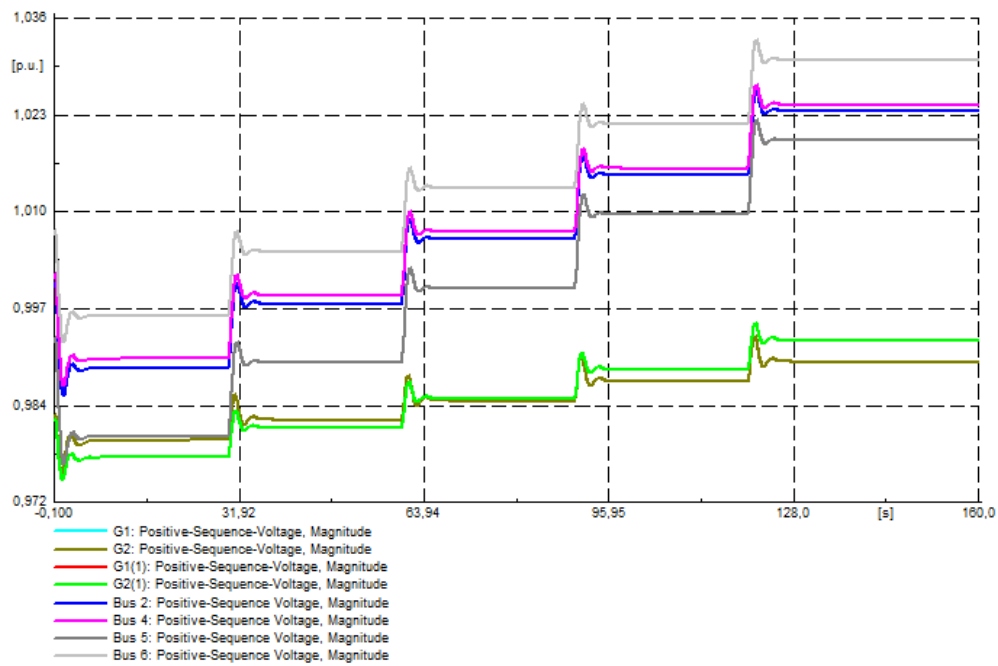

Figure 61: Voltage responses when droop is applied, and the measurements are taken from the transformer's secondary side

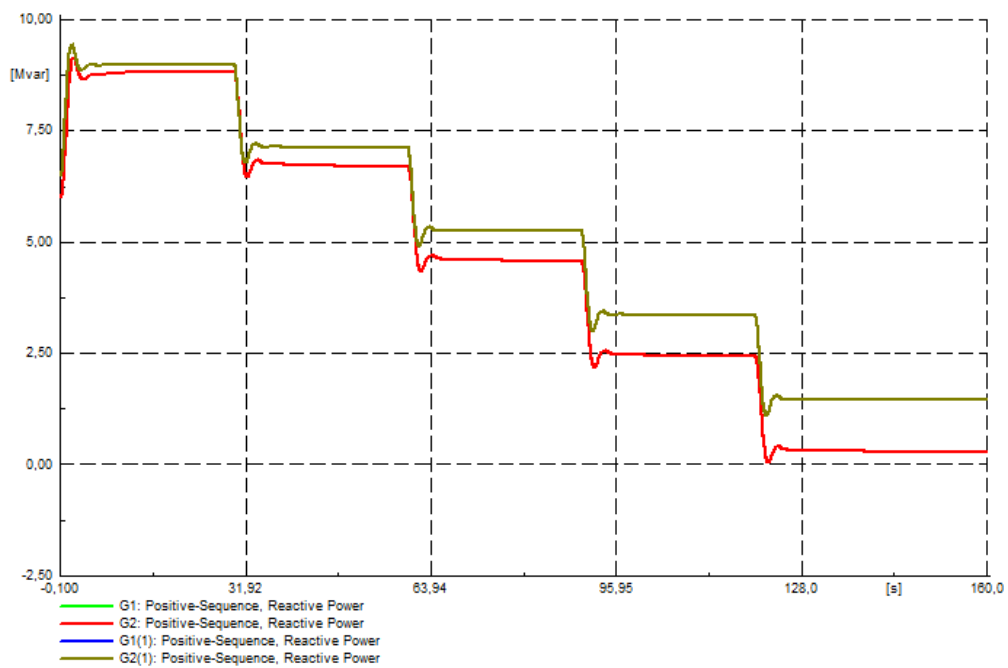

Figure 62: Responses in reactive power when droop is applied, and the measurements are taken from the transformer's secondary side

U_{setp} [p.u.]	V_{bus1} [p.u.]	V_{bus2} [p.u.]	Q_{G1} [MVA _r]	V_{bus3} [p.u.]	V_{bus4} [p.u.]	$Q_{G1(1)}$ [MVA _r]
0.98	0.980	0.989	8.825	0.978	0.991	8.983
0.99	0.982	0.998	6.708	0.981	0.999	7.123
1.00	0.985	1.006	4.580	0.985	1.007	5.249
1.01	0.988	1.015	2.441	0.989	1.016	3.360
1.02	0.990	1.023	0.290	0.993	1.024	1.456

Table 19: Q and V for the power stations when the measurements are taken from the transformer's secondary side, and droop is applied

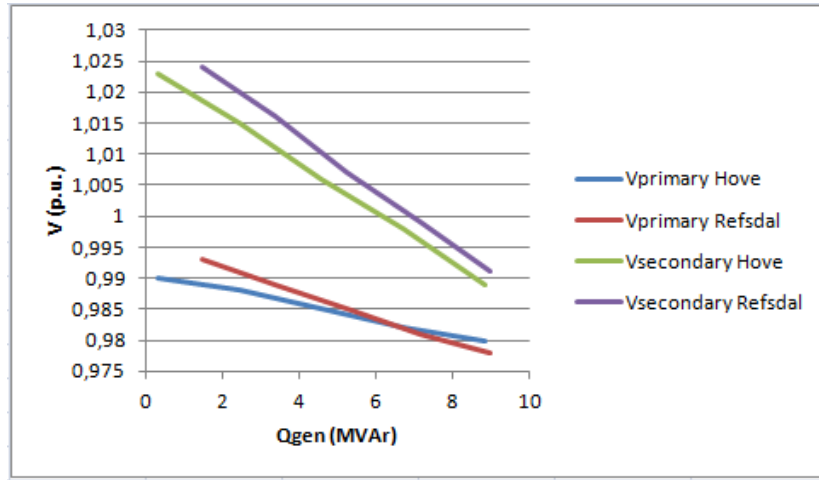

Figure 63: VQ-characteristics for the power stations when the measurements are taken from the transformer's secondary side, and droop is applied

The simulation presented above considered an ideal case with identical operation of the two generators. For the actual operation, ideal and identical operating conditions can not be assumed, as nothing is ideal in a real system. Even though there was a net droop on the secondary side now, it was decided to investigate how the power system responded under unideal circumstances. A new simulation changing the voltage set point for generator $G1$ in Hove was therefore performed. The system became unstable when unideal operating conditions were considered. The unstable responses in voltage and reactive power are shown in figures 64 and 65 below.

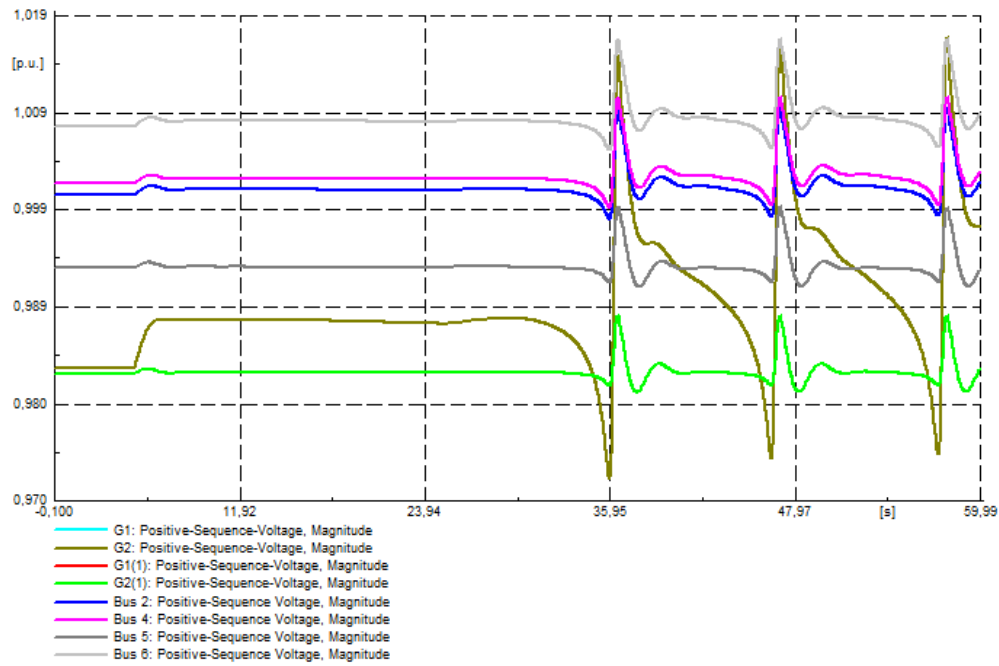

Figure 64: Unstable voltage responses when droop is applied, and unideal operating conditions are considered

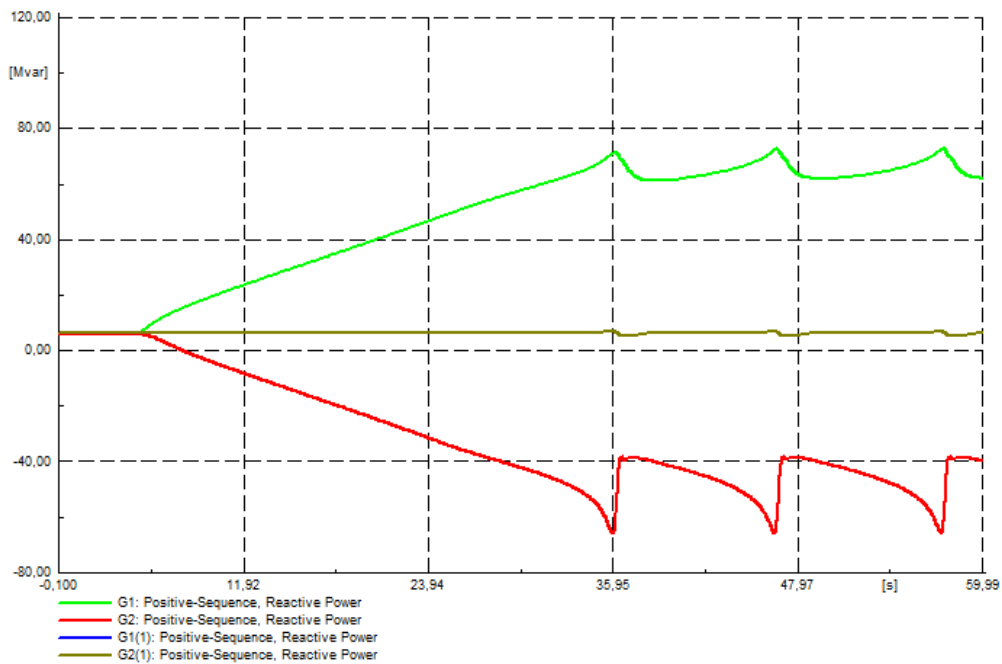

Figure 65: Unstable responses in reactive power when droop is applied, and unideal operating conditions are considered

8.5 Trying to Tune the Droop Settings for Various Voltage Ranges

8.5.1 Tuning of the Applied Droop in a System Utilizing Primary Side Measurements

For the following simulation the whole system was taken into consideration, and the voltage in the system was changed from 0.975 p.u. to 1.025 p.u., according to the voltage variations given by Statkraft. The generators were still connected to a strong grid, with measurements taken from the transformer's primary side. The droop functionality, implemented for the model utilizing generator side measurements, was adjusted in order to investigate how much droop was needed. The simulation should take Statnett's demands regarding contribution into account, and the generators should have a stable operation. It was decided to first investigate the system's behaviour when neither droop nor compensation was applied. The simulation showed that the generators operated within their limits regarding reactive power generation, and hence no droop had to be applied in order to comply with the excitation limits. The responses in voltage and reactive power when neither droop nor compensation was applied are shown in figures 66 and 67.

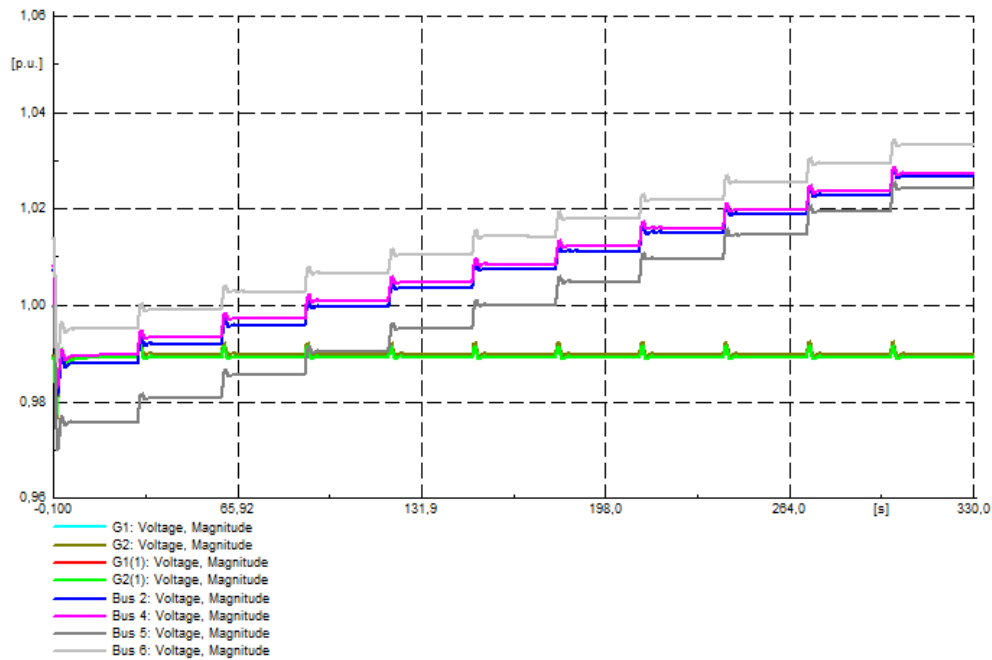

Figure 66: Voltage responses for the system when the measurements are taken from the transformer's primary side, and a voltage range from 0.975 p.u. to 1.025 p.u. is considered

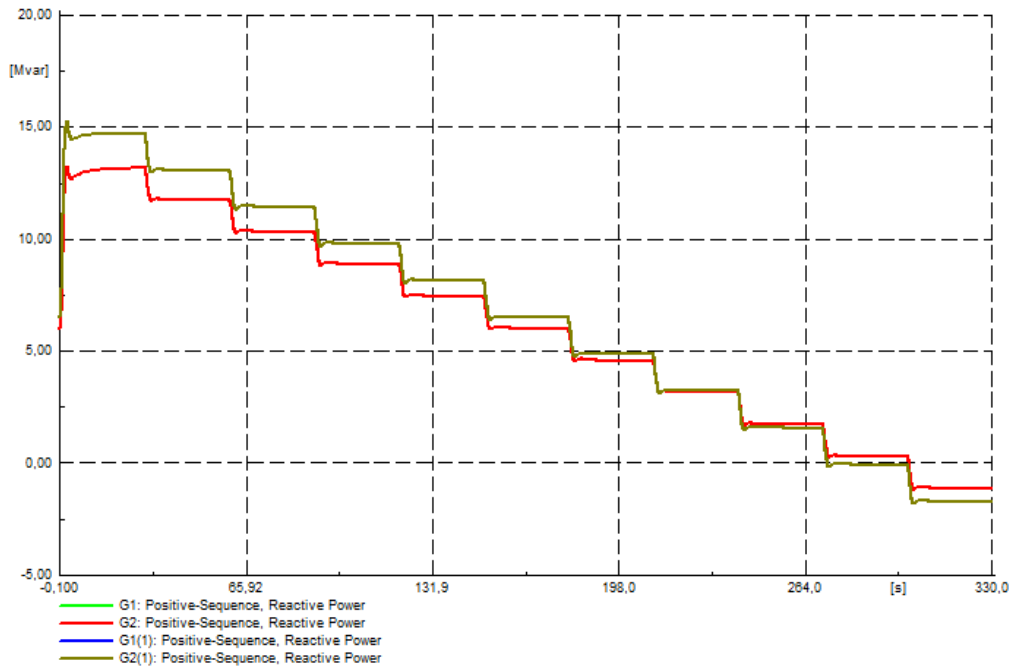

Figure 67: Responses in reactive power for the system the measurements are taken from the transformer’s primary side, and a voltage range from 0.975 p.u. to 1.025 p.u. is considered

8.5.2 Tuning of the Applied Droop in a System Utilizing Primary Side Measurements, When the Continuous and Temporary Voltage Limits in FIKS Are Considered

For the following simulation the whole system was taken into consideration, and the system voltage was changed according to Statnett’s limits for allowed continuous and temporary voltage, i.e. 0.93 - 1.00 p.u. and 0.90 - 1.05 p.u.. The generators were still connected to a strong grid, with measurements taken from the transformer’s primary side. The droop functionality, implemented for the model utilizing generator side measurements, was adjusted in order to investigate how much droop was needed, in order to fulfill Statnett’s demands regarding contribution to voltage control. The values for voltage and reactive power when the droop was adjusted to the different voltage limits are given in tables 20 and 21 below. The VQ-characteristics are given in figures 68 and 69. The reactive powers are given for one machine, and Q_{G1} and $Q_{G1(1)}$ denotes the reactive power supply for the generators in Hove and Refsdal respectively.

U_{setp} [p.u.]	V_{bus1} [p.u.]	V_{bus2} [p.u.]	Q_{G1} [MVar]	V_{bus3} [p.u.]	V_{bus4} [p.u.]	$Q_{G1(1)}$ [MVar]
0.93	0.966	0.950	17.846	0.985	0.953	28.775
0.94	0.970	0.958	16.202	0.986	0.961	25.698
0.95	0.973	0.967	14.520	0.986	0.969	22.510
0.96	0.977	0.975	12.828	0.987	0.977	19.317
0.97	0.980	0.983	11.134	0.987	0.984	16.119
0.98	0.983	0.991	9.431	0.988	0.992	12.919
0.99	0.986	0.999	7.721	0.988	1.000	9.673
1.00	0.990	1.007	6.005	0.989	1.008	6.508

Table 20: Q and V for the power stations, when trying to tune the droop considering the continuous voltage limit

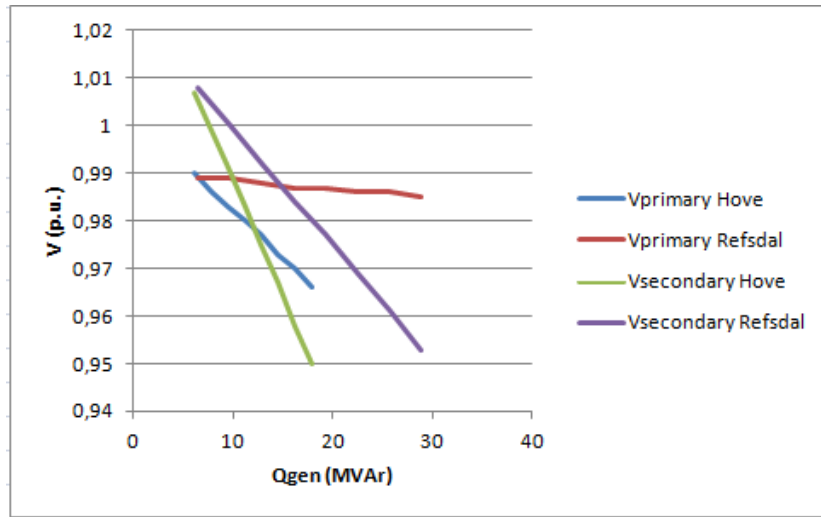

Figure 68: VQ-characteristics for the power stations, when trying to tune the droop considering the continuous voltage limit

U_{setp} [p.u.]	V_{bus1} [p.u.]	V_{bus2} [p.u.]	Q_{G1} [MVar]	V_{bus3} [p.u.]	V_{bus4} [p.u.]	$Q_{G1(1)}$ [MVar]
0.90	0.940	0.921	17.936	0.958	0.923	28.601
0.91	0.945	0.929	16.799	0.961	0.932	26.474
0.92	0.950	0.938	15.622	0.964	0.940	24.295
0.93	0.954	0.947	14.439	0.967	0.949	22.105
0.94	0.959	0.955	13.236	0.970	0.957	19.906
0.95	0.964	0.964	12.056	0.973	0.966	17.673
0.96	0.969	0.973	10.856	0.977	0.974	15.478
0.97	0.974	0.981	9.651	0.980	0.983	13.250
0.98	0.979	0.990	8.440	0.983	0.991	11.011
0.99	0.985	0.999	7.224	0.986	1.000	8.762
1.00	0.990	1.007	6.002	0.989	1.008	6.504
1.01	0.995	1.016	4.775	0.992	1.017	4.236
1.02	1.000	1.025	3.543	0.995	1.026	1.957
1.03	1.005	1.033	2.304	0.999	1.034	-0.331
1.04	1.001	1.042	1.064	1.002	1.043	-2.630
1.05	1.015	1.051	-0.188	1.005	1.051	-4.939

Table 21: Q and V for the power stations, when trying to tune the droop considering the 15 minute temporary voltage limit

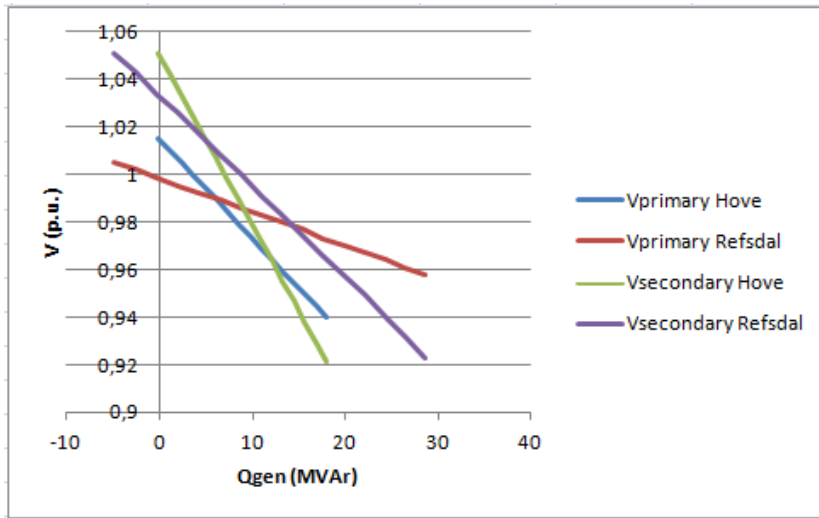

Figure 69: VQ-characteristics for the power stations, when trying to tune the droop considering the 15 minute temporary voltage limit

9 Discussion of the Results

In this part of the report the simulation results will be commented and discussed. The results to be discussed concern the power system's behaviour when the different simulations were performed. These simulations comprise e.g. voltage drop across a transformer, the effect of utilizing primary and secondary side measurements, the effect of applying compensation, tuning of the droop settings when considering several voltage ranges, and the effect of changing the AVR's voltage set point in correspondence with the system's voltage changes. These different aspects were considered in order to come up with suggestions to how the regulation might be improved.

9.1 Investigating the Manner of Operation for the Current Control Strategy

For the simulations investigating the existing control strategy, which results were presented in sections 8.1.1 and 8.1.2, it was found that the reactive power supply was quite constant when the set points of the generators were changed in correspondence with the system's voltage changes. This was an expected result, as the AVRs would not act on the voltage changes in the grid due to the change in set points. Hence, they would supply a quite constant amount of reactive power. Based on the normal load flow conditions and the tuning of the control system, the generators can be controlled such that they does almost not supply any reactive power at all. I.e., by utilizing this strategy, the power producer is able to deliver a quite constant amount of reactive power.

A disadvantage with this strategy, adjusting the set points, is that the power producer is providing little voltage support and reactive power reserves to the system. For the simulations in sections 8.1.1 and 8.1.2, i.e. when considering cases both with and without reactive droop, the voltages at the secondary side varied with 4.0% in both Hove and Refsdal. This was expected since the AVRs were adjusting their set points according to the grid voltage. Consequently they would not give any contribution to voltage control. It should also be noticed from figures 26 and 27 that the reactive power supply was somewhat reduced when droop was included. This was also an expected result considering the the general droop characteristic.

When considering the simulation done in section 8.1.2 it was observed that the reactive power supply changed quite much, when comparing the periods where the

set point was adjusted in correspondence with the grid voltage to the periods where the adjustment was not done yet. This showed that a fast regulation is advantageous if this strategy is to be used. Otherwise, large swings in reactive power supply could occur.

In the real system, the two power stations are making larger adjustments of reactive power supply than what was shown in these simulations. I.e., they might give a larger contribution to voltage control. Still, the tuning of the AVRs, with respect to reactive power supply, is such that the generators' reactive power capacity is distributed over a voltage range of approximately $\pm 13\%$. I.e., for a small voltage change the adjustment in reactive power supply will be quite small, but still larger than what was the result for these simulations. The amount of contribution given will of course depend on how the set points are adjusted, with respect to the system changes. With a different tuning this strategy could provide a satisfactory control, but as long as the regulation is done manually it will not be a favourable solution. This will be further commented in section 10.1

9.2 Investigating Droop and Compensation, When Considering Voltage Drop Across a Transformer

9.2.1 Investigating Voltage Variations with Respect to Active and Reactive Power Supply

The voltage variations at the generators' terminals and the voltage drop across the transformers was studied in section 8.2.1. Figures 30-32 showed how the voltages at the transformer in Hove's primary and secondary side varied for different system voltages, and different supply of active and reactive power. When studying these figures it was found that large absorption or generation of reactive power brought the voltage at the secondary side somewhat away from the system voltage. The change in secondary side voltage was about 3%, when comparing the cases with maximum absorption and maximum generation. This change was quite small compared to the voltage change that occurred at the generators' terminals. Here the voltage varied with approximately 10%, which is considered as a typical range for the generators' terminal voltage, as mentioned in section 2.1.9. This implied that the reactive power supply had a large impact on the voltage at the generators' terminals. When comparing the three figures 30-32 and considering the variations in active power, it was found that the voltages were almost unaffected by the change in active power supply.

The study showed that the voltage variations and voltage drop were mainly caused by the reactive power exchange. The voltage variations were expected when considering load flows, as the voltage at the generator's terminals must be higher when much reactive power is supplied and injected in the grid, and consequently the voltage at the transformer's secondary side will become higher due to the injected reactive power, and vice versa. The reason for why the secondary side voltage varied less compared to the terminal voltage, was due to the grid's stabilizing effect. As the voltage in the connected grid was kept constant at the three different levels, i.e. 0.97 p.u., 1.00 p.u. and 1.03 p.u., this contributed to stabilize the voltage at the secondary side, despite the relatively large voltage variations at the generators' terminals. The trend was the same for Refsdal power station, which results were shown in appendix A.2.1. In order to obtain a more stable voltage at the transformer's secondary side, compensation can be applied in the control system. This will though be discussed later in this report.

9.2.2 Studying Droop and Compensation for a Single Generator

The impact of droop and compensation in a system with a single generator, whose AVR was taking measurements from the transformer's primary side, was proved by some simple simulations. The results were shown in sections 8.2.2-8.2.4. With no droop or compensation included, the voltage at the primary side remained constant due to the regulation provided by the AVR, as the AVR would try to keep a stable voltage at the generator's terminals. This was shown in figure 33. The voltage at the transformers' secondary side would, on the other hand, decrease with increased supply of reactive power, i.e. with decreased system voltage. When considering the generator's reactive power supply and the voltage at the transformer's secondary side, a droop of approximately 12% was found. The droop was caused by the transformer reactance, which was about 11%. I.e., there was some deviation between the value of the reactance and the droop calculated from the simulations. This deviation was though rather small and could be a result of inaccuracy in the simulation or measurements.

Figure 34 showed how the voltage at the transformer's secondary side varied less when compensation was introduced. As already mentioned, compensation in this context means negative reactive droop, and for this simulation the compensation was added by utilizing the droop functionality implemented for the AVR as described in section 6.2. The compensation applied was of 5%, and hence the resulting droop at the transformer's secondary side was reduced to approximately 7%. By compensating for some of the voltage drop across a transformer, a more precise

voltage control could therefore be obtained. The compensation made it possible to achieve a more constant voltage at the transformer's secondary side, and hence the contribution to maintain a constant grid voltage was improved. By increasing the applied compensation, the voltage at the secondary side could become even more stabilized. Hence, for cases where one generator is connected to a transformer, compensation can be a good way to improve the power producer's contribution to voltage control. The effect of applying compensation for generators connected to a common transformer will be commented later in this report.

When droop was applied for the generator's AVR, the voltage at the transformer's secondary side varied more, compared to the two previous cases considered in this section. The relation between primary and secondary side voltages when droop was applied was shown in figure 35. The droop applied was of 5%, increasing the resulting droop at the secondary side to approximately 17%. Including droop was in this case unfavourable as the stability of the grid voltage was reduced. A positive effect of introducing droop was, on the other hand, that the reactive power supply from the machine was reduced. Including droop could therefore be advantageous in cases where the generators often tend to go into saturation. This was also stated in the specialization project *Voltage Control and Sharing of Reactive Power* from autumn 2015. I.e., the tuning of droop and compensation must take the connected grid and the generator's capacity into consideration. Also, the transformers' reactance must be taken into account.

9.3 Investigating the Effect of Droop and Compensation, When Taking the Measurements Given to the AVR from the Generators' Terminals

9.3.1 Changing the System Voltage When Compensation Is Studied for One Generator in Hove Power Station

When studying primary side measurements and compensation for one generator in Hove, the purpose was to investigate contribution to voltage control and also the grid's impact on the generator, as mentioned in section 8.3.1. In the first simulation the goal was to obtain a constant voltage at the transformer in Hove's secondary side when considering a weaker grid drawing little reactive power, and hence compensation must be applied. In order to apply a suitable compensation the transformer reactance must be considered. When referring the reactance to the generator's rating, it was found to be of approximately 4,66%. This would imply a droop on the

secondary side of about 4.66%, when no droop or compensation was applied. When compensating the transformer reactance, referred to the generator's rating, the relation between voltage and reactive power became as given in table 12. To obtain a stable voltage at the transformer's grid side, a net compensation of 4.61% was applied at the generator side. I.e., the transformer reactance was cancelled out by the applied compensation. There was only a small deviation between the calculated reactance and the actual compensation, that must be applied in order to obtain a constant secondary side voltage, and the simulation was therefore quite precise.

As mentioned in section 8.3.1, the values for voltage and reactive power in table 12 indicated that the compensation applied in order to achieve a constant voltage at the transformer's grid side was too large, as the generator's excitation limits were exceeded. This means that the generator was not able to obtain a constant voltage in this weak grid, drawing relatively little reactive power, and the compensation must be reduced. A new simulation was therefore done, and the new values for voltage and reactive power were given in table 13. The voltage and reactive power responses were shown in figures 36 and 37. The new compensation provided by the generator was about 4.38%, and the resulting droop at the grid side became approximately 0.29%. The generator must utilize most of its available capacity to be able to keep a quite constant secondary side voltage. Hence, the generator was very exposed to experiencing saturation due to large overexcitation, if the system state changed and the grid were drawing more reactive power. When a stronger grid drawing more reactive power was considered the compensation must be adjusted such that the generator did not go into saturation. The maximum net compensation that could be applied in this case was found to be of only 0.14%, giving a droop of 4.89% at the secondary side. The responses in voltage and reactive power for a stronger grid were shown in figures 39 and 40.

For both cases, considering a weak and a strong grid, the generator must utilize most of its reactive power capacity. As already mentioned, this made the generator very exposed to going into saturation. In a weak grid the generator in Hove could give a quite large contribution to voltage control, whereas the generator could almost not give any contribution at all when a strong grid was considered. Based on these simulations it can be stated that the generator's capacity, and the grid in which the generator is connected, have a considerable impact on what contribution a generator is capable of giving when considering voltage control. A similar study was performed for a generator in Refsdal power station, which results were presented in appendix A.2.2. The results of those simulations were quite similar to the ones discussed in this section.

9.3.2 Investigating the Effect of Droop and Compensation on Generators Operating in Parallel

The effects of droop and compensation on generators operating in parallel were illustrated by some fundamental simulations in sections 8.3.2 and 8.3.3. These simulations showed the same characteristics, when ideal operating conditions were assumed, as what was found when one generator was studied in sections 8.2.2-8.2.4. I.e., the paralleled generators would have constant voltages at the terminals when neither droop nor compensation was applied. This was shown in figure 42. Figure 43 showed the VQ-characteristics when compensation was applied. The inclusion of compensation made it possible to compensate for some of the voltage drop across the transformers, and consequently the voltage range at the secondary side was reduced. Hence, the voltage stability was improved. As ideal operating conditions were assumed, these results were expected based on the findings in sections 8.2.2 and 8.2.3. When unideal conditions were considered and droop was not applied, responses as the one showed in figure 44 were obtained. Hence, compensation can not be applied when operating paralleled generators and utilizing measurements from the generators' terminals. In a real system, where small differences between the paralleled units always will be present, some droop should therefore be applied in order to obtain stable generator operation. These simulations still indicated that the applied droop did not have to be large for such small voltage variations, as the generators were able to operate within their excitation limits.

When droop was applied, the results in section 8.3.3 showed that the voltages decreased for increasing generation of reactive power on both sides of the transformers. For the secondary side the steepness of the VQ-characteristic was increased, compared to the cases without droop applied. This was due to an increased resulting droop on the transformers' secondary side when droop was applied for the AVRs. The increase reflected the additional droop applied on the primary side, i.e. 5% and 10% in Hove and Refsdal respectively, and the resulting droops on the secondary side were now approximately 15.04% and 23.30%. By including droop the voltage range was increased, and the variations in reactive power were reduced. This simulation also showed how the voltage drop across the transformer increased when two machines were operated. The voltage drops across the transformers were now about twice as large, compared to the cases with only one machine operating in section 8.3.1 and appendix A.2.2. For these simulations there where though no additional droop applied. Unideal operating conditions were also studied for this case. The responses in voltage and reactive power, when a change in voltage set point for one generator in Hove was done, were shown in figures 46 and 47 in section 8.3.3. These simulations showed that the system remained stable for such a disturbance, due to

the applied droop. If droop was not applied the generators could start opposing each other and create instability. The stability was obtained as the droop provided a new sharing of reactive power. This was illustrated in figure 11 in section 2.1.7.

As ideal operation can not be assumed for a real system, compensation can not be utilized when operating paralleled generators and utilizing measurements from the generators' terminals. I.e., to ensure stable generator operation, when operating multiple generators that are connected to a common transformer, other ways to improve the voltage control must therefore be utilized. In the specialization project *Voltage Control and Sharing of Reactive Power* it was also found that droop should be applied in order to achieve stable generator operation. However, in this thesis another possibility, taking the measurements given as input to the AVRs from the transformer's secondary side, will be investigated. This will be further discussed in section 9.4 below.

9.4 Investigating the Effect of Droop and Compensation, When Taking the Measurements Given to the AVR from the Transformer's Secondary Side

9.4.1 Changing the System Voltage When Compensation Is Studied for One Generator in Hove Power Station

When investigating secondary side measurements and compensation for one generator in Hove, the goal was to investigate the contribution to voltage control and the grid's impact on the generator. The simulations were done to compare the system behaviour when utilizing secondary side measurements, to the system behaviour when utilizing primary side measurements. It was decided to first consider a case where the generator was connected to a weak grid, drawing relatively little reactive power. The voltage responses in figure 48 in section 8.4.1, showed that the voltage at the transformer's grid side, or secondary side, became stable when the transformer reactance was taken into account. The transformer reactance referred to the generator's rating was approximately 4,66%, as mentioned in section 9.3.1. To obtain a stable voltage at the transformer's grid side, the reactance in the estimation function used in this model was adjusted. The estimation function was in this case tuned such that the transformer reactance was taken into account, without applying any additional droop or compensation. The values for voltage and reactive power given in table 16 showed that the net compensation at the generator side, due to the utilization of secondary side measurements, was of 4.83%, in order to obtain a

stable secondary voltage. I.e., there was approximately no compensation applied for the generator other than the compensation for the transformer reactance, as the measurements were taken from the secondary side. There was a small deviation between the calculated reactance and the actual compensation that must be applied, but the deviation was rather small. The simulation was therefore quite precise.

When the generator was connected to a strong grid drawing more reactive power, the reactance in the estimation function must be adjusted if the secondary side voltage should become stable. Several values were tested for the reactance, but it turned out that the grid was too strong. I.e., it was not possible to obtain a constant secondary side voltage and at the same time have a stable system. The voltage response in figure 51 showed that the generator was able to maintain a constant voltage at the generator's terminals, but it was not able to give a contribution to compensate for the transformer reactance. The resulting droop at the secondary side became about 4.91%. When the compensation at the generator was increased the system became unstable, as shown in figures 54 and 55. The reason for this instability was that the generator's stability limits were exceeded, and hence pole slip occurred. As mentioned in section 2.1.4, pole slip is caused by low magnetization when the generator is absorbing reactive power. When the rotor angle then reaches 90° , the generator steps out of phase [15].

The results in section 8.4.1 made it possible to identify how the reactance in the estimation function should be adjusted, in order to obtain a voltage at the secondary side that had a better profile. As for the simulations in section 8.3.1, investigating compensation when utilizing primary side measurements, it was found that the generator must utilize most of its reactive power capacity in order to provide a constant voltage at the transformers secondary side. Still the generator's ability to contribute to voltage control was very limited, due to the machine's capacity and the impact of the grid, even though the measurements were taken from the transformer's grid side. Hence, it was difficult for the generator to contribute to keep the grid voltage constant. A similar study was also performed for a generator in Refsdal power station, which results were presented in appendix A.2.3. The results of those simulations were similar to the ones discussed in this section.

Even though the ranges of voltage and reactive power were quite equal for the cases utilizing primary and secondary side measurements, it should though be noticed that the reactive power supply were different for the two cases investigating primary and secondary side measurements. This was because the reference now was based on the transformer's grid side. When the voltage reference given to the AVR was taken from the secondary side, the generator operated with a lower voltage set point. Hence, the reactive power supply was lower compared to section 8.3.1. When

comparing the results in sections 8.3.1 and 8.4.1 it was found that there was no clear advantages by utilizing secondary side measurements. This was also expected when considering one generator operating alone.

9.4.2 Investigating the Effect of Droop and Compensation on Generators Operating in Parallel

In section 9.3.2 droop and compensation were discussed for paralleled generators, when taking the measurements from the generators' terminals. A similar study was done to investigate this when utilizing measurements from the transformers' secondary side, in order to compare the effect of utilizing these two different measuring points. As both paralleled generators were now operated, the reactance was doubled compared to the simulations in section 8.4.1 and appendix A.2.3. For the simulation studying the effect of having no droop or compensation applied in section 8.4.2, it was expected to obtain VQ-characteristics similar to the ones in figure 50 in section 8.4.1. On the contrary, figures 56 and 57 showed how the generators were trying to keep a stable secondary side voltage, when no additional droop or compensation was applied in the estimation function, without succeeding. The responses in voltage and reactive power showed that the system became unstable, even though ideal operating conditions were assumed for the simulation. The instability was caused by pole slip, and indicated that utilization of secondary side measurements made the system more fragile.

Compensation was also studied for the system utilizing secondary side measurements, to investigate whether this strategy could provide stability, and hence to see whether compensation could be applied for paralleled generators. Even though the loading and settings were identical and the case was considered as ideal, the system became unstable when additional compensation was applied. The instability increased compared to the case without any droop or compensation applied. It was though not surprising that the system became unstable for this case, when considering the instability that occurred when neither droop nor compensation was applied.

Instability also occurred when primary side measurements were utilized and unideal operating conditions were considered in section 8.3.2. The simulations therefore proved that not applying droop, when operating paralleled generators, causes instability irrespective of what measuring points are utilized. Hence, applying compensation is not a viable solution to improve the contribution to voltage control when considering multiple generators connected to a common transformer. This

was perhaps not very surprising, considering the fact that the measurements were more or less taken from the same point, only different due to some offset caused by the transformers' reactances.

When a droop of 5% and 10% was applied for each AVR in Hove and Refsdal respectively, there was still a net compensation at the generator side as the transformer reactance was taken into consideration. This was illustrated in figure 60 in section 8.4.3. The compensation was though smaller compared to the case in section 8.4.2, as some droop was included. In order to compare the effect of having a net droop on the generator side, when measuring on the primary and secondary side, it was decided to increase the droop at the generators such that the resulting droop on the primary side became 5% and 10% in Hove and Refsdal respectively. The VQ-characteristics for these two simulations, utilizing primary and secondary side measurements, were given in figures 45 and 63, in sections 8.3.3 and 8.4.3 respectively. When comparing these cases it was found that the range of the voltage variations were equally large based on tables 15 and 19. It was also found that the range of reactive power variations were quite similar for the two cases as well. In addition, it was decided to investigate how the system utilizing secondary side measurements responded to unideal operating conditions, when there was a net droop on the generators' terminals. It was expected that the system should remain stable due to the droop, as for the simulation in section 8.3.3, and it was therefore quite surprising to find that instability occurred. This was shown in figures 64 and 65. By increasing the droop when studying this unideal case, the instability was reduced. Still, it was difficult to obtain stability for this system.

I.e., utilizing secondary side measurements provided a less robust control when considering stability, compared to the case where the measurements were taken from the generators' terminals. One reason for why the system was now more unstable, was that there was now a large effective compensation on the generator side, as the transformer reactance should be compensated. Based on the results discussed in this section, it can be stated that there is no great advantages utilizing measurements from the secondary side for this system, as this strategy did not improve the regulation. The simulations also indicated that this strategy provided larger stability problems. Hence, for such a system it will be better to utilize the more common strategy, taking the measurements from the generators' terminals. It could though be beneficial to utilize secondary side measurements when considering voltage drop across both a transformer and a line. I.e., secondary side measurements may be useful in some cases. This will be further commented in chapter 12.

9.5 Trying to Tune the Droop Settings for Various Voltage Ranges

At first it was planned to tune the droop for various voltage ranges and different control strategies, i.e. both for utilizing measurements from the generators' terminals and from the transformers' secondary side. The results of the simulations investigating secondary side measurements, discussed in section 9.4.2, however stated that there were no advantages utilizing measurements from the transformers' grid side, and hence there was no point in tuning the droop settings for this control strategy.

9.5.1 Tuning of the Applied Droop in a System Utilizing Primary Side Measurements

For the simulation in section 8.5.1, considering an ideal system, it was found that there was no need to add droop in order to comply with the generators' excitation limits, when considering a system voltage change from 0.975 p.u. to 1.025 p.u.. The voltage changes, and hence the variations in reactive power were relatively small, and, as shown in figure 67, the generators were consequently working within their excitation limits. Also, the demands regarding reactive power supply, given by Statnett, were fulfilled. Still, some small droop must be applied for a real system in order to ensure stable generator operation, as already commented.

9.5.2 Tuning of the Applied Droop in a System Utilizing Primary Side Measurements When the Continuous and Temporary Voltage Limits in FIKS Are Considered

In order to operate the generators for the more wide-ranging voltage limits considered in section 8.5.2, it was found that droop must be applied. When considering Statnett's voltage limits for continuous operation, it was found that a droop of 7% should be applied for the generators in Hove, in order to comply with the excitation limits and to fulfill Statnett's demands regarding voltage control. I.e., the generators should be able to operate within $\cos \phi$ limits of 0.86 capacitive and 0.95 inductive. For the generators in Refsdal the droop must be of 1%. The resulting droop on the transformers' secondary sides then became about 17.3% and 14.1% respectively. When the voltage limits for temporary operation up to 15 minutes were considered, the droop must be increased as a consequence of a larger allowed voltage range. It was then found that the droop tuning in Hove should be of 15%,

while a droop of 8% should be applied in Refsdal. The resulting droops at the secondary sides then became approximately 25.8% and 21.8% respectively. The simulations indicated that the generators in Refsdal could give a larger contribution to voltage control, due to their larger capacity compared to the generators in Hove. I.e., as these generators are capable of delivering a larger amount of reactive power, a smaller droop is needed in order to comply with the excitation limits.

These simulations indicated that the tuning of the droop should be changed. With a larger droop, as the one obtained from the regulation scheme, the generators would not give a good contribution as the reactive power contribution is distributed over a large voltage range. By considering a smaller voltage range, as the ones considered in this section, the contribution to voltage and reactive power control will be improved. Also, the number of set point adjustments that have to be done are reduced, compared to today's procedure.

10 Discussion of Other Topics

In this chapter, suggestions to solutions that might provide an improved regulation of the power stations, that are not investigated in this thesis, will be discussed. There are probably other possibilities that could improve the regulation as well, but in the following section some different strategies will be mentioned. Also different control strategies and Statnett's requirements regarding voltage control will be evaluated.

10.1 Other Suggestions for Possible Solutions to Improve the Regulation

Based on the knowledge acquired in the work with the specialization project and this master thesis, other solutions to improve the regulation will be discussed in this section. One suggestion to regulation procedure could be to apply a secondary control loop. This loop could calculate a new set point, based on the measurements, and give it to the AVRs. Hence, there would be no need to manually give a new set point as the secondary control loop would handle this. Based on how the set points are calculated, different values for droop could be utilized. By using such a control strategy, the principles for control utilized in the power stations today will be pursued. As the regulation would not depend on manual adjustments, the control will be simplified and easier to carry out for the power producer. Such a strategy might provide a better coordinated regulation, that would also be easier to manage. It would have been very interesting to investigate this manner of regulation, and if there were more time this should have been prioritized.

Another possibility is to use a common AVR to control the paralleled generators. By utilizing such a strategy the generators would receive the exact same signals. The generators would consequently not oppose each other as they are always controlled and operated in the same manner. A clear disadvantage with this strategy is that it presumes identical operation of the two generators, as the AVR can not give different control signals to each of the paralleled generators. This will therefore probably not be a good solution, as it should be possible to have different operations for the generators. Hence, other control strategies should be applied, such as utilizing a common secondary loop. Still it could have been interesting to test this strategy.

In addition to suggestions providing an easier control when considering the power producer, a suggestion that may also improve the overall voltage control will be

presented. Based on the simulations discussed in sections 9.2.2, 9.3.1 and 9.4.1, it was found that single operated generators could give some contribution to keeping a constant voltage at the transformer's grid side. This would, as already mentioned, depend on the grid's and the generator's capacity. Still, if the generators were able to compensate for some of the voltage drop across a transformer this could be useful considering the overall control of the system. It would therefore have been interesting to investigate the possibility of utilizing a software to change the AVR's tuning, dependent on the number of generators connected to a common transformer, that were operated. When operating several machines droop must be applied, as stated in the previous simulations. But for situations where only one generator is operated, no droop is needed and some compensation could possibly be applied, dependent on the system in which the generator is connected. Hence, the contribution to voltage and reactive power control in the system might be improved.

Another possibility that might be advantageous, is to modify the power stations such that each generator has its own transformer. In this way the problems related to the control of paralleled generators can be avoided. In addition, the generators would not need to have droop applied. Hence, they might be able to provide more reactive power, in order to improve the overall voltage control in the system. This will though be a costly solution for Statkraft, compared to e.g. installing a secondary control loop.

10.2 Evaluation of Different Control Strategies

Preferably reactive power should be balanced at the point of consumption. This requires several reactive power compensating devices in the grid, e.g. such as those mentioned in section 2.1.9. The benefits of compensating reactive power at the point of consumption is that transmission of reactive power is not necessary. This makes it possible to utilize more of the line capacity for transmission of active power. Also, the transmission losses are reduced. A disadvantage with this control strategy is that it requires investments in additional components in the grid.

By utilizing the synchronous generators to control voltage and reactive power, the costs related to other compensating elements can be lowered, as the need for additional compensating devices is reduced. Also the number of components in the grid to be monitored and maintained is reduced. A disadvantage with the strategy utilizing synchronous generators for regulation in a larger scale, is that the generation or absorption of reactive power in the generator causes slightly increased production losses. Increased transmission losses is of course another drawback.

Which strategy to be used should therefore be determined dependent on the grid's construction, loading, and condition. Voltage variations and the generators' ability to deliver or absorb reactive power should also be considered. I.e., the strategy to be used should be chosen based on the system as a whole.

10.3 Evaluation of Statnett's Requirements Regarding Voltage and Reactive Power Control

In chapter 4 the current voltage control of the power stations were described. In addition, the requirements from Statnett regarding voltage control and provision of reactive power reserves, were explained. It was found that Statnett's demands, when considering the voltage limits for continuous operation, implied a resulting droop at the transformers' secondary side of 8.51%. When considering the transformer reactances in the two power stations, when operating both paralleled generators, it was found that the reactances themselves were larger than this resulting droop. When operating single generators Statnett's requirements could be fulfilled by applying compensation, if the reactance provides a voltage drop that is too large. That is though not an option for parallel operation. This implies that it would be difficult for the power producers, operating multiple generators connected to a common transformer, to meet this demand. If the power producers want to provide a regulation according to Statnett's requirements, unstable generator operation will be the result if a net compensation is applied at the terminals of paralleled generators. Otherwise, a control strategy frequently adjusting the AVRs' set points is needed. Based on this, and the fact that transformer reactances of about 11% is common, Statnett's demands should perhaps allow a larger droop on the transformer's grid side. In other words, Statnett's requirements should maybe be reconsidered for generators operated in parallel.

On the other hand, if Statnett's requirements were eased for generators connected to a common transformer, and more power producers chose to operate their power stations with multiple generators connected to a common main transformer, there might occur problems in the power system due to a lack of reactive power supply. Such a development is not desirable. In order to be able to discuss this further, and give recommendations for how to meet the challenges related to Statnett's requirements and the control of paralleled generators, more simulations should be done, considering the cooperation between Statnett and the power producers. Hence, it could be interesting to study how the voltage control would be in cases where either all power stations were providing reactive power, according to what was needed in the grid, or where the provision of reactive power was minimal.

11 Conclusion

For this system it was found that the voltage variations at the generators' terminals and the voltage drop across the transformers, were mainly related to the change in reactive power. The voltage variations were almost unaffected by the active power supply. This was expected as the supply of reactive power depends on the voltage at the terminals and in the grid. It was also found that the voltages at the transformers' grid side varied less than the voltages at the generators' terminals, due to the impact of the grid.

The simulations done in this thesis investigating the effect of utilizing measurements from the transformer's grid side, showed that there were no clear advantages with using this strategy. The stability was not improved, and the variations in voltage and reactive power remained equally large. This was found both for the cases considering one generator operating alone, and for the cases where two generators were connected to a common transformer. When considering paralleled generators, it was also found that utilization of secondary side measurements did not contribute to improve the communication between the machines, and stable generator operation when droop was not applied was not obtained. It was therefore not possible to utilize secondary side measurements to improve the voltage stability at the secondary side, by applying compensation when operating paralleled generators. As the regulation was not improved by using measurements from the secondary side, it might be easier to utilize measurements from the generators' terminals in the control of voltage and reactive power for this system. Measuring further away from the generator might be advantageous for some cases, though. The measurements could then be taken from a bus with important loads connected, etc., and the voltage at this point might be controlled in a more precise manner. This was though not studied in this thesis.

The simulations investigating tuning of the AVRs with respect to various voltage intervals, showed that different droop settings should be applied in order to improve the regulation. In today's system the droop in Hove and Refsdal is of 5% and 10% respectively at the generators. But when considering the current regulation procedure, the resulting droop at the secondary side is of about 33% in Hove and 38% in Refsdal. These droops are large, and the generators will hence not give much of a contribution to voltage and reactive power control. In order to obtain a better tuning of the AVRs, the power producer must first determine what voltage variations the droop should be adjusted to. If the power producer wants to avoid changing the AVR's set points, even when large voltage variations are considered, a large droop is needed. On the other hand, if a smaller voltage range is considered,

a larger contribution to regulation could be given if the droop is reduced. It should though be mentioned that the resulting droop on the grid side is dependent on both the droop at the generators and the transformer voltage drop. If the tuning is based on the voltage variations given by Statkraft, only a small droop is needed in order to ensure stable operation of the paralleled machines. When considering the limits for continuous operation a larger droop of 7% should be applied at the generators in Hove. The generators in Refsdal have a larger capacity, and hence a droop of only 1% is needed for this voltage range.

The simulations investigating one generator operating alone, showed that the generators might be able to contribute to improve the overall voltage control in the system. For a single operated generator compensation could be applied, and hence a more constant voltage might be obtained at the transformer's secondary side, dependent on the grid in which the generator is connected. At least the generators were able to keep a constant voltage at the terminals without exceeding the excitation limits. To utilize this possibility in a way that is easy to handle for the power producer, a software able to adjust the tuning of droop and compensation, with respect to the operating state, should be developed. This possibility was also commented in section 10.1.

It should also be mentioned that Statnett's requirements for voltage control and provision of reactive power reserves, might be difficult for the power producers to meet, when operating paralleled generators. The simulations and analytical evaluations indicated that the resulting droop at the transformers' grid side, when taking the transformer reactance into account, were larger than what was found considering Statnett's requirements. I.e., in order to meet these demands the power producers, operating multiple generators connected to a common transformer, might have to utilize less common control strategies, such as applying secondary control loops. Another possibility might be to modify the power stations, such that each generator has it's own transformer. As mentioned in section 10.3, it would also be advantageous to study the cooperation between Statnett and the power producers further, in order to investigate other aspects of this topic. This might be done by carrying out system simulations, considering Statnett's requirements regarding voltage and reactive power control, and the power stations' contribution to regulation.

12 Suggestions for Further Work

In order to give specific advices to how the voltage control ought to be done, a more detailed model should might be made. In this thesis more probable voltage intervals were studied compared to the specialization project, and the secondary side voltages were taken into account. Still, it could be advantageous to make a more accurate model. Various operating states, and the system's behaviour when exposed to more extreme scenarios, should might be investigated as well, as this thesis mainly considers operating states which can be characterized as normal. In addition it could be interesting to investigate the effect of utilizing measurements from a point in the grid when the aim is to compensate for voltage drop across both a transformer and a line. This could be interesting to study, as it is assumed that measurements from other points than the generator's terminals would be more beneficial in such a case. Such a control strategy would perhaps be most advantageous for industries that depend on a stable power supply, such as aluminium production. I.e., for a company like Hydro, having both power production and aluminium production, this might be a favourable control strategy to apply. This strategy should though be avoided for power stations with multiple generators connected to a common transformer, as it reduces the stability.

Other suggestions for further work could be to develop a software that allows the tuning of the AVR, with respect to droop and compensation, to be changed in correspondence with the operating state. I.e., the software should make it possible to apply a suitable compensation when only one of the multiple generators is operated, and also apply the necessary droop when several machines are operated. This was also mentioned in section 10.1. Section 10.1 also discussed a possible solution to improved and simplified regulation by applying a secondary control loop, that is able to calculate the set points given to the AVRs. The principles of today's control strategy would then be pursued, but the regulation will not depend on manual operation. Hence, the regulation will be easier to carry out for the power producer. This could therefore be advantageous to study further.

In addition it might be interesting to study the cooperation between Statkraft and Statnett further, as mentioned in section 10.3. This might be done by carrying out system simulations, in order to investigate how the voltage control would be if all power producers adjusted their reactive power supply according to what was needed in the grid, or if no power stations were supplying reactive power. Such simulations could also indicate what amount of additional control, provided by FACTS devices, etc., would be needed in the different scenarios. For such simulations it could be advantageous to use another simulation program, e.g. PSS®E.

References

- [1] Statnett, “Funksjonskrav i kraftsystemet (fiks),” 2012.
- [2] E. Veum, “Voltage control and sharing of reactive power,” 2015.
- [3] J. Machowski, J. W. Bialek, and J. R. Bumby, *Power system dynamics: stability and control*. Chichester: Wiley, 2nd ed. ed., 2008.
- [4] P. Kundur, J. Paserba, V. Ajjarapu, G. Andersson, A. Bose, C. Canizares, N. Hatziargyriou, D. Hill, A. Stankovic, C. Taylor, T. Van Cutsem, and V. Vittal, “Definition and classification of power system stability,” *IEEE*, vol. 19, pp. 1387–1401, 2004.
- [5] O. B. Fosso and K. Uhlen, “Generator controls - excitation systems and voltage control, turbines and turbine governors.” Lecture notes TET4180, 2015-03-02, 2015.
- [6] N. Martins, S. Corsi, C. Taylor, C. Vournas, C. Cañizares, G. N. Taranto, G. Fabrice, H. Lefebvre, J. Paserba, J. van Hecke, J. Sanchez-Gasca, J. C. R. Ferras, K. Uhlen, L. Pereira, M. Pozzi, M. C. Perdomo, N. Miller, P. Kundur, T. van Cutsem, and V. Ajjarapu, “Coordinated voltage control in transmission networks,” tech. rep., Cigre Task Force C4.602, 2007.
- [7] W. K. Chen, *The Electrical Engineering Handbook*. Burlington: Elsevier Science, 2004.
- [8] A. v. Meier, *Electric power systems: a conceptual introduction*. Hoboken, N.J: IEEE Press Wiley-Interscience, 2006.
- [9] *Handbook of Electrical Power System Dynamics: Modeling, Stability, and Control*. Hoboken, NJ, USA: John Wiley & Sons, Inc., 2013.
- [10] S. J. Chapman, *Electric machinery fundamentals*. New York: McGraw-Hill, 5th ed. ed., 2012.
- [11] P. Kundur, N. J. Balu, and M. G. Lauby, *Power system stability and control*. The EPRI power system engineering series, New York: McGraw-Hill, 1994.
- [12] S. Corsi, *Voltage Control and Protection in Electrical Power Systems : From System Components to Wide-Area Control*. Voltage Control and Protection in Electrical Power Systems, London: Springer London, 2015.

- [13] “Recommended models for overexcitation limiting devices,” *Energy Conversion, IEEE Transactions on*, vol. 10, no. 4, pp. 706–713, 1995.
- [14] G. R. Berube, L. M. Hajagos, and R. E. Beaulieu, “A utility perspective on under-excitation limiters,” *Energy Conversion, IEEE Transactions on*, vol. 10, no. 3, pp. 532–537, 1995.
- [15] M. Kvistad and Nilsen, *Elektriske maskiner og magnetiseringsutstyr*. Oslo: Elforl., 1999.
- [16] J. G. Balchen, B. A. Foss, T. Andresen, and N. teknisk-naturvitenskapelige universitet Institutt for teknisk kybernetikk, *Reguleringsteknikk*. Trondheim: Institutt for teknisk kybernetikk, Norges teknisk-naturvitenskapelige universitet, 5th ed., 2003.
- [17] “Ieee recommended practice for excitation system models for power system stability studies,” *IEEE Std 421.5-2005 (Revision of IEEE Std 421.5-1992)*, 2006.
- [18] P. Schavemaker and L. van der Sluis, *Electrical Power System Essentials*. Chicester: Wiley, 2008.
- [19] “Discover the world of facts technology.” http://www.energy.siemens.com/hq/pool/hq/power-transmission/FACTS/FACTS_Technology_.pdf. Accessed: 2016-2-10.
- [20] “Static var compensation (svc).” [http://new.abb.com/facts/static-var-compensation-\(svc\)](http://new.abb.com/facts/static-var-compensation-(svc)). Accessed: 2016-2-8.
- [21] “Proposed terms and definitions for flexible ac transmission system (facts),” *IEEE Transactions on Power Delivery*, vol. 12, pp. 1848–1853, Oct 1997.
- [22] “Statcom - svc light.” <http://new.abb.com/facts/statcom>. Accessed: 2016-2-8.
- [23] J. L. Kirtley, *Transformers*. Chichester, UK: Chichester, UK: John Wiley Sons, Ltd, 2011.
- [24] “Digsilent powerfactory - power system dynamics.” http://www.digsilent.de/index.php/products-powerfactory-power_system_dynamics.html#bottom. Accessed: 2015-12-15.

A Appendix

A.1 Modelling of the System

A.1.1 AVR, Droop and Compensation

As mentioned in section 6.2 the droop functionality was not implemented for the AVRs available in PowerFactory, and a new droop model was therefore made. The droop functionality, utilizing primary side measurements, was implemented by PhD candidate Lester Kalemba for the specialization project autumn 2015. It was decided to implement the droop function, when the measurements were taken from the generator side, in the PSS slot of the generator frame. In this way the adjusted voltage signal was given as an input to the AVR through the PSS gate. This was done because it simplified the practical implementation of the function. By utilizing the PSS slot for the droop functionality, a PSS could not be applied in the models, and hence the simulations were done without any PSSs. The resulting droop frame is shown in the following figure.

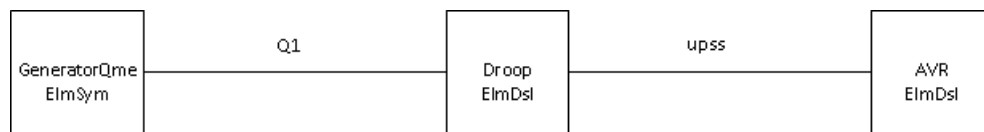

Figure 70: Droop frame

As shown in figure 70, the droop function was implemented such that it received measurements of reactive power from the generator terminal. The difference between the measured reactive power and the reference value was multiplied with a droop constant, and then given as input to the AVR. In the actual system the HPC 185 AVRs receive measurements of voltage and current, but for simplicity it was chosen to use the reactive power measured on the generator terminal as input to the AVRs in this model.

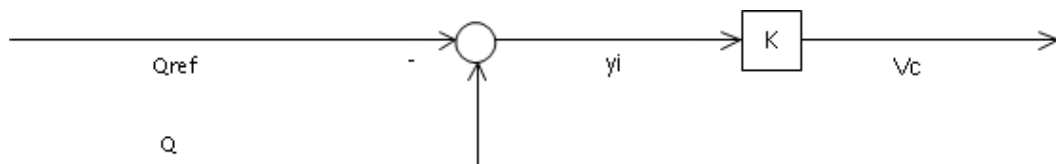

Figure 71: The loop utilized for applying droop and compensation, when the measurements are taken from the transformer's primary side

In section 6.2 it was also mentioned that this thesis should investigate the effect of moving the measurements to the transformer’s secondary side as well. Consequently, the models had to be adjusted such that it was possible to utilize this type of measurements, and PhD candidate Lester Kalemba was helpful in order to make the new models working. The use of secondary side measurements was implemented by using a function in PowerFactory called *drp_COMP*, which made it possible to estimate the voltage in some point outside the generator, e.g. at the transformer’s secondary side. The *drp_COMP* function will in these models take the voltage reference and the current measurement from the secondary side. In order to be able to utilize measurements from the secondary side, the composite model frame that was to be used, SYM Frame 1, must be changed. I.e., instead of taking the current measurement from the generator terminal, an additional current measurement must be included to be able to get measurements from the secondary side. Equation (28) and figure 72 below shows how the *drp_COMP* function works.

$$V_c = V_{term} - jX_e I_{gen} \tag{28}$$

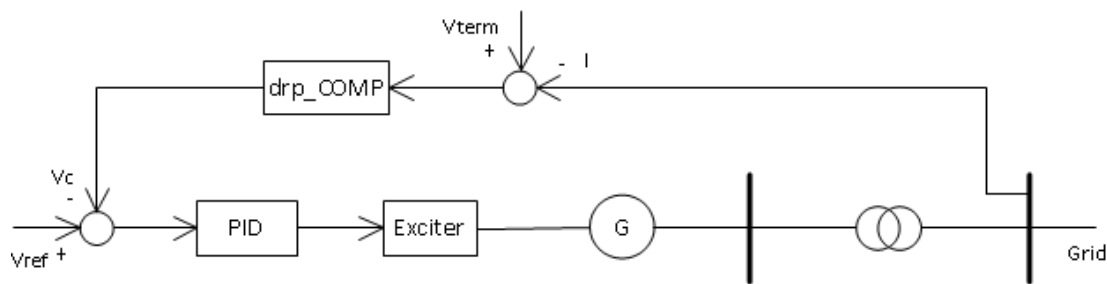

Figure 72: The loop utilized for applying droop and compensation, when the measurements are taken from the transformer’s secondary side

As explained in section 6.2, variable V_c in the equation above represents the compensated voltage, i.e. the voltage given as input to the AVR. The AVR will hence try to control the voltage based on this input. V_{term} represents the voltage at the generator terminal, while I_{gen} is the current from the generator. When studying generators operated in parallel, this current will be the total current delivered by both generators.

Parameter X_e can be adjusted depending on the transformer reactance and what amount of droop or compensation is wanted. I.e., both droop and compensation could be investigated by using this function, and hence the transformer voltage drop could be taken into account in order to obtain a more constant voltage at the transformer’s grid side. When the X_e parameter was set to the negative transformer

reactance, a constant voltage was obtained at the transformer's secondary side. I.e., there was no additional droop or compensation applied in the *drp_COMP* function. When applying a positive value for X_e a net droop was applied at the primary side, whereas a negative X_e parameter provided compensation. If the negative X_e parameter had an absolute value larger than the transformer reactance, a net compensation was applied at the primary side. By testing this function it was found that it worked quite well.

A.2 Simulations, Results and Discussion

A.2.1 Investigating Voltage Variations with Respect to Active and Reactive Power Supply for Refsdal Power Station

As for the the study on Hove power station in section 8.2.1, the voltages at the transformer in Refsdal's primary and secondary side were to be studied for different active and reactive power supplies. In the figures the active power supply was set to 0%, 50% and 100%, and the curves show how the voltage at the primary side, i.e. at the generator terminals, varied for increasing supply of reactive power. Also, three different system voltages were considered, that is 0.97 p.u., 1.00 p.u. and 1.03 p.u. The results were obtained by using the ordinary load flow analysis for different cases. Figures 73-75 below show the voltage curves for the transformer in Refsdal power station, when the voltage at the generators' terminals and the voltage drop across the transformer were studied. In the figures the lower dots represented absorption of reactive power, whereas the upper dots represented large generation of reactive power.

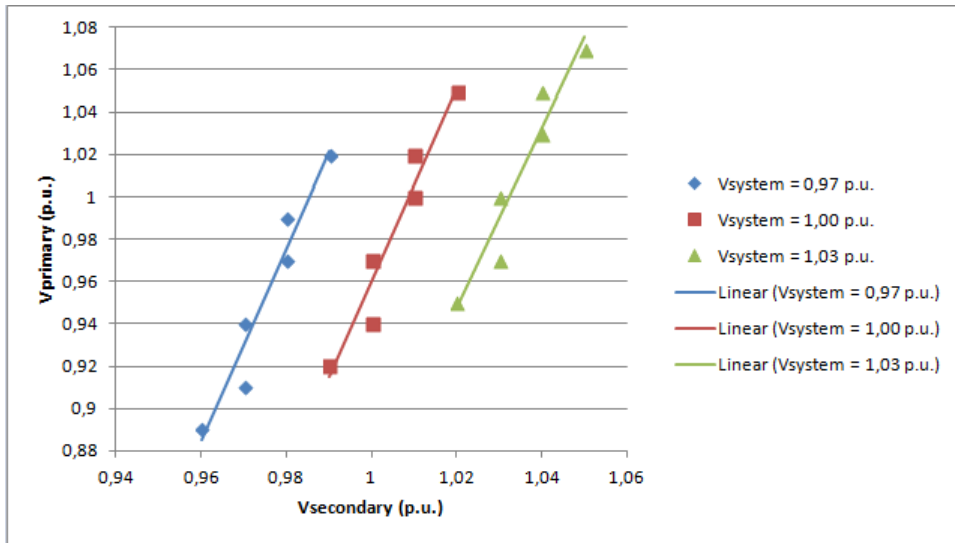

Figure 73: Voltage drop across the transformer in Refsdal when the generators are not delivering any active power

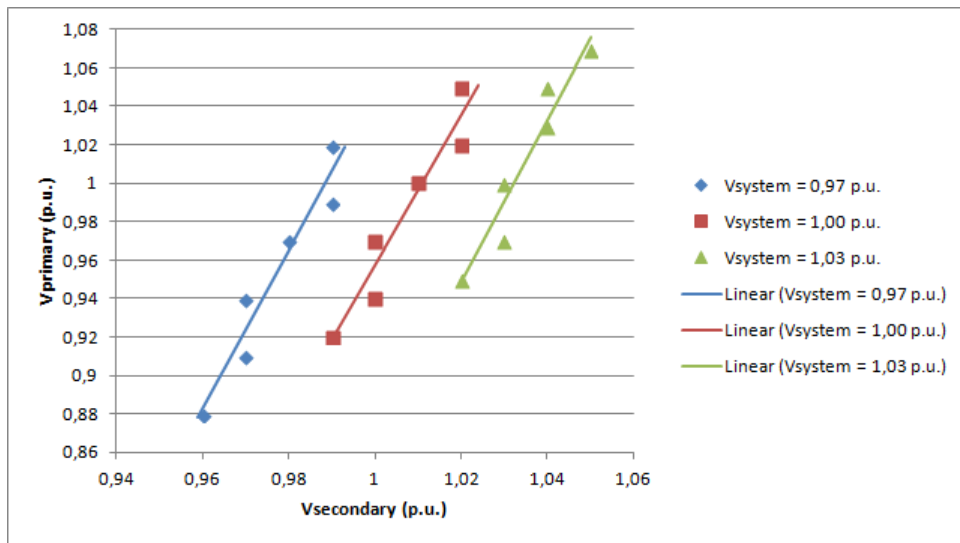

Figure 74: Voltage drop across the transformer in Refsdal when the generators are delivering 50% active power

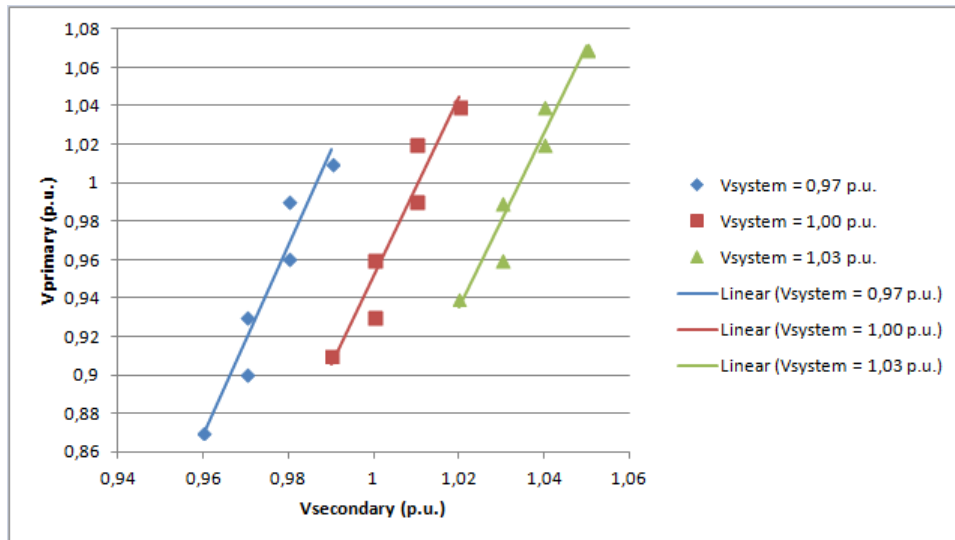

Figure 75: Voltage drop across the transformer in Refsdal when the generators are delivering 100% active power

When studying these figures, it was found that large absorption or generation of reactive power brought the voltage at the secondary side somewhat away from the system voltage. The change in secondary side voltage was about 3%, when comparing the cases with maximum absorption and maximum generation. This change was quite small compared to the voltage change that occurred at the generators' terminals. Here the voltage varied with approximately 12-14%. This was quite similar to what was found for the transformer in Hove, in section 9.2.1. The voltage variations at the generator bus were slightly higher than what is considered as a typical range for the generators' terminal voltage of $\pm 5\%$, as was mentioned in section 2.1.9.

As for the transformer in Hove, the results implied that the reactive power supply had a large impact on the voltage at the generators' terminals. When comparing the three figures 73-75, and considering the variations in active power, it was found that the voltages were almost unaffected by the change in active power supply. I.e., the study showed that the voltage variations and voltage drop were mainly caused by the reactive power exchange. The voltage variations were expected when considering load flows, as the voltage at the generator's terminals must be higher when much reactive power is supplied and injected in the grid, and consequently the voltage at the transformer's secondary side will become higher due to the injected reactive power, and vice versa. As mentioned in section 9.2.1, the reason for why the secondary side voltage varied less compared to the terminal voltage, was the

grid's impact. As the voltage in the connected grid was kept constant, at different levels, this contributed to stabilize the voltage at the secondary side, despite the relatively large voltage variations at the terminals.

A.2.2 Changing the System Voltage When Compensation Is Studied for One Generator in Refsdal Power Station, and Primary Side Measurements Are Utilized

As for the simulation in section 8.3.1, compensation was applied in order to obtain a constant voltage at the transformer's grid side. The purpose of doing the simulation was to investigate what contribution the generator was capable of giving, considering voltage control. The system voltage was changed by adjusting the large synchronous machine's voltage set point from 0.98 p.u. to 1.02 p.u., and as a consequence the reactive power supply from the generator in Refsdal was changed. Figure 76 below shows the relation between voltage and reactive power when the system voltage varied. The figure is based on the measurements presented in table 22.

U_{setp} [p.u.]	$V_{primary}$ [p.u.]	$V_{secondary}$ [p.u.]	Q_{G1} [MVar]
0.98	1.001	1.011	20.594
0.99	0.993	1.011	13.518
1.00	0.985	1.011	6.524
1.01	0.978	1.011	-0.274
1.02	0.970	1.011	-6.902

Table 22: Q and V for a generator in Refsdal connected to a weaker grid, when the measurements are taken from the transformer's primary side

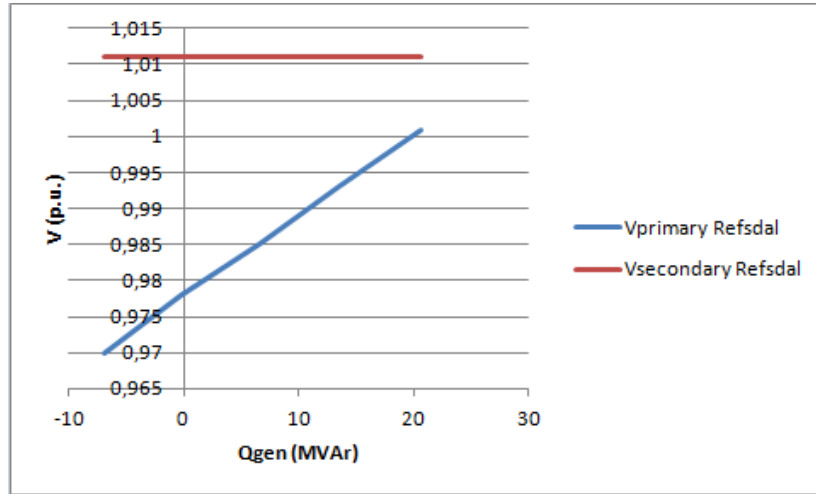

Figure 76: VQ-characteristic for a generator in Refsdal when a weaker grid is considered, and the measurements are taken from the transformer’s primary side

In addition, it was decided to investigate the generator’s behaviour when connected to a strong grid drawing more reactive power, to see what compensation the generator was capable of providing then. The values for voltage and reactive power for this case are given in table 23, and the corresponding VQ-characteristic is given in figure 77.

U_{setp} [p.u.]	$V_{primary}$ [p.u.]	$V_{secondary}$ [p.u.]	Q_{G1} [MVar]
0.98	0.986	0.986	28.827
0.99	0.981	0.994	17.603
1.00	0.976	1.002	6.416
1.01	0.971	1.009	-4.405
1.02	0.966	1.017	-15.157

Table 23: Q and V for a generator in Refsdal connected to a strong grid, when the measurements are taken from the transformer’s primary side

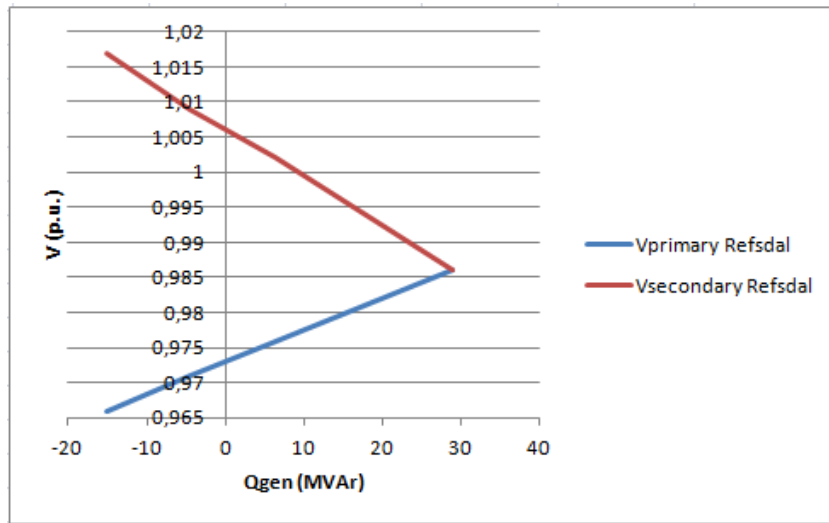

Figure 77: VQ-characteristic for a generator in Refsdal when a strong grid is considered, and the measurements are taken from the transformer’s primary side

As for the simulation discussed in section 9.3.1, the goal of this simulation was to try to obtain a constant voltage at the transformer’s secondary side, but now the transformer in Refsdal was considered. To achieve this, compensation was added as described in section 8.3.1. The relation between voltage and reactive power, when compensating the transformer reactance referred to the generator’s rating, became as shown in figure 76 when a weak grid was considered. The resulting compensation at the generator side was calculated to be approximately 6.44%. I.e., in order to obtain a constant voltage at the transformer’s secondary side, when only one generator was operated, a compensation of 6.44% must be applied at the generator. This corresponded quite well to the value for the transformer’s reactance, when referred to the generator’s rating, of 6.28%. In this weak grid the generator had some capacity left. Hence, the generator had the ability to manage larger voltage variations, or a grid drawing more reactive power, without going into saturation.

When considering a strong grid, drawing more reactive power, the generator was not able to give a similar contribution without exceeding the excitation limits. The applied compensation should therefore be reduced. The amount of compensation that should be applied in order to meet Statnett’s demands regarding voltage control was of 2.60%, and hence the resulting droop on the transformer’s grid side would be approximately 4,02%. When comparing the generator’s operation in this system to the one in the weaker system, it is clear that the generator must now utilize more of it’s capacity, and it can consequently not handle increased reactive power demand in the same way.

A.2.3 Changing the System Voltage When Compensation Is Studied for One Generator in Refsdal Power Station, and Secondary Side Measurements Are Utilized

For the following simulations only one generator in Refsdal power station was operated. The other machines in the power stations were disconnected. As for the simulations in section 8.4.1, the aim was to investigate the effect of taking the measurements from the secondary side when one generator was operating alone. The system voltage was changed from 0.98 p.u. to 1.02 p.u.. In order to change the compensation for the different cases, the estimation function's reactance was adjusted.

The first simulation for the generator in Refsdal, investigated the voltage drop across the transformer when the generator was connected to a weak grid, as explained in section 8.4.1. Table 24 shows the values for voltage and reactive power, and figure 78 shows the relation between voltage and reactive power for this simulation.

U_{setp} [p.u.]	$V_{primary}$ [p.u.]	$V_{secondary}$ [p.u.]	$Q_{G1(1)}$ [MVar]
0.98	0.989	1.004	15.257
0.99	0.981	1.004	8.675
1.00	0.974	1.004	2.187
1.01	0.967	1.004	-4.203
1.02	0.959	1.004	-10.495

Table 24: Q and V for a generator in Refsdal connected to a weaker grid, when the measurements are taken from the transformer's secondary side

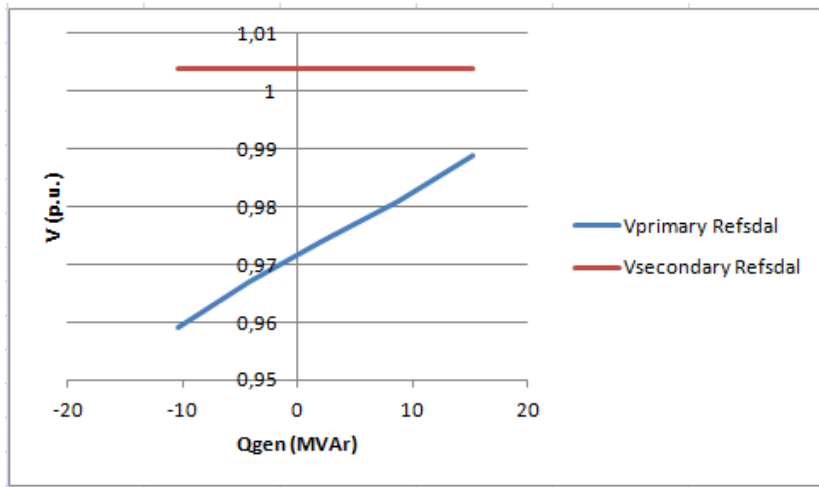

Figure 78: VQ-characteristic for a generator in Refsdal when a weaker grid is considered, and the measurements are taken from the transformer’s secondary side

The second simulation also investigated the voltage drop, but the generator was now connected to a strong grid, drawing more reactive power. Figure 79 shows the voltages at the transformer’s primary and secondary side with respect to reactive power generation, and is based on the values presented in table 25.

U_{setp} [p.u.]	$V_{primary}$ [p.u.]	$V_{secondary}$ [p.u.]	$Q_{G1(1)}$ [MVar]
0.98	0.973	0.984	18.366
0.99	0.971	0.992	9.466
1.00	0.968	1.000	0.598
1.01	0.966	1.008	-8.229
1.02	0.964	1.016	-17.014

Table 25: Q and V for a generator in Refsdal connected to a strong grid, when the measurements are taken from the transformer’s secondary side

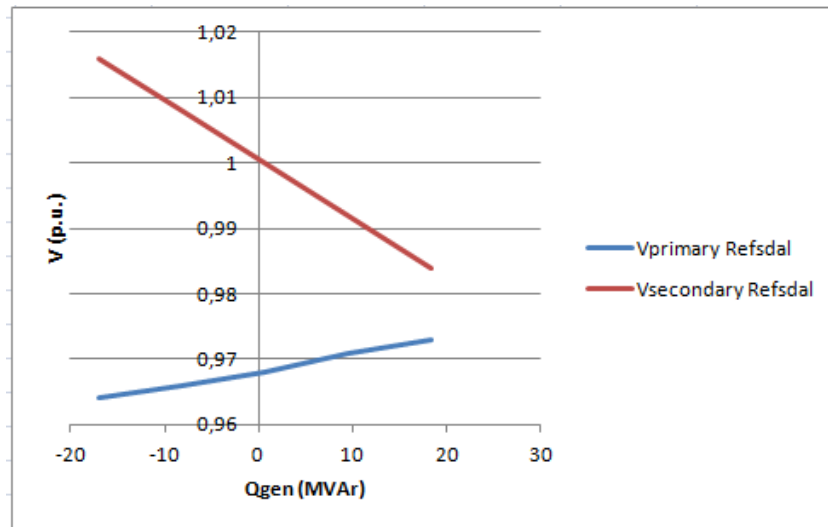

Figure 79: VQ-characteristic for a generator in Refsdal when a strong grid is considered, and the measurements are taken from the transformer’s secondary side

When considering a weak grid the voltage at the transformer’s grid side, or secondary side, became stable. This was shown in figure 78 above. The generators were taking the voltage drop across the transformer into account, as the measurements were now taken from the secondary side. When referring the transformer reactance in Refsdal to the generator’s rating, the reactance was found to be of approximately 6.28%. To obtain a constant voltage at the transformer’s grid side the reactance in the estimation function was adjusted such that this reactance was taken into account, providing a net compensation at the primary side. I.e., no additional compensation was applied. The simulation showed that a small additional compensation must be applied in order to obtain a constant secondary side voltage. The resulting primary side compensation was of 6.65%. I.e., there was a small deviation for this simulation.

As mentioned in section 9.4.1, the net compensation at the generator side must be increased if the secondary side voltage should become constant when the generator was connected to a strong grid drawing more reactive power. Various values for the reactance in the estimation function were tested, but as for the generator in Hove, the grid was too strong. Consequently, the secondary side voltage did not become constant. The generator was in this case only capable of giving a compensation of approximately 1.45%, and it was hence not able to account for the transformer reactance. The droop at the secondary side then became about 5.16%. I.e., the generator did not have the necessary capacity to ensure a constant voltage at the transformer’s grid side when connected to a strong grid. When comparing these

results to the ones in section A.2.2 it was found that there was no clear advantages of utilizing secondary side measurements. This was also expected when considering one generator operating alone.