



Norwegian University of
Science and Technology

Condition Monitoring for Predictive Maintenance:

A Tool for Systems Prognosis within the
Industrial Internet Applications

Douglas Okafor
Chukwuekwe

Reliability, Availability, Maintainability and Safety (RAMS)

Submission date: August 2016

Supervisor: Per Schjøllberg, IPK

Co-supervisor: Tommy Glesnes, Karsten Moholt AS

Norwegian University of Science and Technology
Department of Production and Quality Engineering

By order of Rector: 20 January 2012

STANDARD AGREEMENT

concerning work on a master's thesis/project assignment (academic work) done in cooperation with a company/external organization (organization).

This is the authoritative agreement that governs academic work by students at the Norwegian University of Science and Technology (NTNU) that is carried out in cooperation with an organization.

The involved parties have the responsibility to clarify whether or not a third party (that is not a party to this agreement) may have intellectual property rights to the project background before the latter is used in connection with the academic work.

Agreement between

Student: <i>CHUKWUEKWE, Douglas Okafor</i>	Date of birth: dd-mm-yy <i>11-03-79</i>
---	--

Supervisor at NTNU: <i>PER SCHJØLBERG</i>

Company/external organization: <i>KARSTEN MOHOLT AS</i>

and

Norwegian University of Science and Technology (NTNU), represented by the Head of Department
--

concerning the use and exploitation of the results from a master's thesis/project assignment.

1. Description of the academic work

The student is to carry out

Master's thesis	<input checked="" type="checkbox"/>
Project assignment	<input type="checkbox"/>

(insert cross)

In cooperation with

<i>KARSTEN MOHOLT AS</i>

company/external organization:

26-02-16 to 22-07-16

starting date – completion date (dd-mm-yy)

Title of the academic work:

Condition Monitoring for Predictive Maintenance:
A TOOL for Systems Prognosis within the Industrial Internet Paradigm

The responsible supervisor at NTNU has overall academic responsibility for structuring and approving the description of the academic work and the student's learning.

2. Responsibilities of the organization

The organization is to appoint a contact person who has the necessary experience in supervision and will give the student adequate supervision in cooperation with the supervisor at NTNU. The contact person at the organization is:

Mr. TOMMY GLESNES

The purpose of completing the academic work is academic training for the student. The academic work is part of a student's course of study and the student is not to receive wages or similar compensation from the organization. The organization agrees to cover the following expenses that are associated with carrying out the academic work:

3. Rights of the parties

a) The student

The student holds the copyright to his/her academic work. All intellectual property rights to the results of the academic work done by the student alone during the academic work are held by the student with the reservations stated in points b) and c) below.

The student has the right to enter into an agreement with NTNU concerning the publication of his/her academic work in NTNU's institutional archive on the Internet. The student has also the right to publish his/her academic work or parts of it in other media providing the present agreement has not imposed restriction concerning publication, cf. Clause 4.

b) The organization

If the academic work is based on or develops materials and/or methods (project background) that are owned by the organization, the project background is owned by the organization. If the development work that includes the project background can be commercially exploited, it is assumed that a separate agreement will be drawn up concerning this between the student and the organization.

The organization is to have the right to use the results of the academic work in its own activities providing the commercial exploitation falls within the activities of the organization. This is to be interpreted in accordance with the terminology used in Section 4 of the Act Respecting the Right to Employees' Inventions (Arbeidstakeroppfinnelsesloven). This right is non-exclusive.

The use of the results of the academic work outside of the activities of the organization, cf. the last paragraph above, assumes that a separate agreement will be drawn up between the student and the organization. The agreement between the student and the organization concerning the rights to the results of the academic work produced by the student is to be in writing and the agreement is invalid until NTNU has received a copy of the agreement in writing.

If the value of the results of the academic work is considerable, i.e. it is more than NOK 100 000, the student is entitled to receive reasonable compensation. Section 7 of the Act Respecting the Right to Employees' Inventions states how the amount of compensation is to be calculated. This right to compensation also applies to non-patentable results. Section 7 of the Act also states the applicable deadlines.

c) NTNU

All copies of the submitted academic work/files containing the academic work and any appendices that are necessary for determining a grade and for the records at NTNU, are the property of NTNU. The academic work and any appendices to it can be used by NTNU for educational and scientific purposes free of charge, except when the restrictions specified in Clause 4 are applicable.

4. Delayed publication

The general rule is that academic work by students is to be available in the public domain. If there are specific circumstances, the parties can agree to delay the publication of all or part of the academic work for a maximum of 3 years, i.e. the work is not available for other students or organizations during this period.

The academic work is subject to delayed publication for:

one year	
two years	
three years	

(insert cross next to the number of years if this clause applies)

The grounds for delayed publication are as follows:

--

The parts of the academic work that are not subject to delayed publication can be published in NTNU's institutional archive, cf. Clause 3 a) second paragraph.

Even if the academic work is subject to delayed publication, the organization is to make it possible for the student to use all or part of his/her academic work in connection with a job application or follow-up work in connection with doctoral study.

5. General

This agreement takes precedence over any other agreements that are or will be entered into by two of the parties mentioned above. In case the student and the organization are to enter into a confidentiality agreement concerning information the student obtains while he/she is at the organization, NTNU's template for a confidentiality agreement is to be used for this purpose. If there is such an agreement, it is to be appended to the present agreement.

Should there be any dispute relating to this agreement, it should be resolved by negotiation. If this does not lead to a solution, the parties agree to the matter being resolved by arbitration in accordance with Norwegian law. Any such dispute is to be decided by Sør-Trøndelag District Court or a body appointed by this court.

This agreement is signed in 4 - four - copies, where each party to this agreement is to keep one copy. The agreement comes into effect when it has been approved and signed by NTNU represented by the Head of Department.

Note that the Norwegian version of this standard agreement is the authoritative version.

Trondheim (08 Apr 16) 
place, date (dd-mm-yy) student

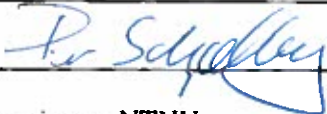
Trondheim 08-04-16 
place, date (dd-mm-yy) supervisor at NTNU

Trondheim, 21.04.2016 
place, date (dd-mm-yy) Head of Department, NTNU

Askoy (19-04-16) 
place, date (dd-mm-yy) for company/organization

signed and stamped



Tel: +47 55 94 34 00
24h emergency: +47 468 55535
firmapost@kmoas.no

STANDARDMAL

ved avtale om konfidensialitet mellom student og bedrift/ekstern virksomhet i forbindelse med studentens utførelse av oppgave (masteroppgave/prosjektoppgave) i samarbeid med bedrift/ekstern virksomhet, jf. punkt 5 i avtale om oppgave i samarbeid med bedrift/ekstern virksomhet. Malen er fastsatt av Rektor ved NTNU 29.08.2011.

AVTALE mellom

Student ved NTNU: <i>CHUKWUEKWE, Douglas Okafor</i>	født: <i>11-03-79</i>
--	--------------------------

Bedrift/ekstern virksomhet: <i>KARSTEN MOHOLT AS</i>

om konfidensialitet.

1. Studenten skal utføre oppgave i samarbeid med bedrift/ekstern virksomhet som ledd i sitt studium ved NTNU.
2. Studenten forplikter seg til å bevare taushet om det han/hun får vite om tekniske innretninger og fremgangsmåter samt drifts- og forretningsforhold som det vil være av konkurransemessig betydning å hemmeligholde for bedriften/den eksterne virksomheten. Det er bedriftens ansvar å sørge for å synliggjøre og tydeliggjøre hvilken informasjon dette omfatter.
3. Studenten er forpliktet til å bevare taushet om dette i 5 år regnet fra sluttdato, jf. standardavtale om utføring av oppgave i samarbeid med bedrift/ekstern virksomhet punkt 1.
4. Kravet om konfidensialitet gjelder ikke informasjon som:
 - a) var allment tilgjengelig da den ble mottatt
 - b) ble mottatt lovlig fra tredjeperson uten avtale om taushetsplikt
 - c) ble utviklet av studenten uavhengig av mottatt informasjon
 - d) partene er forpliktet til å gi opplysninger om i samsvar med lov eller forskrift eller etter pålegg fra offentlig myndighet

Trondheim (08-04-16)

sted, dato

[Signature]

student

Askøy (19-04-16)

sted, dato

Tommy Glesnes (Karsten Moholt AS)

for bedrift/ekstern virksomhet
stempel og signatur



Tel: +47 55 94 34 00

NTNU 2011-08-29

24h emergency: +47 468 55535

firmapost@kmoas.no

Intentionally left blank

Part 1: Main Report

RAMS
Reliability, Availability,
Maintainability, and Safety



NTNU – Trondheim
Norwegian University of
Science and Technology

Condition Monitoring for Predictive Maintenance: A Tool for Systems Prognosis within the Industrial Internet Applications

Douglas Okafor Chukwuekwe

July 2016

MASTER THESIS (TPK4950)

Department of Production and Quality Engineering

Norwegian University of Science and Technology

Supervisor: Per Schjølberg (Associate Professor, NTNU-Trondheim)

Co-Supervisor: Tommy Glesnes (Chief Technical Officer, Karsten Moholt AS)

Preface

This report is submitted in partial fulfilment of the requirements for the award of an MSc degree in the study programme: Reliability, Availability, Maintainability and Safety (RAMS). The thesis was carried out during the Spring semester of 2016. It is particularly focused on using condition monitoring as a maintenance activity to the benefit of predictive maintenance and prognosis within the Industrial Internet of Things (IIoT).

I was inspired to pursue this project topic in the course of my work as a Research Assistant at the NTNU's department of Production and Quality Engineering (IPK) during the Summer of 2015. The theme of the study was proposed by my supervisor, Associate Professor Per Schjølborg. The thesis was carried out in partnership with Karsten Moholt AS with active support from Mr. Tommy Glesnes, the Chief Technical Officer of the company and my co-supervisor. The head of department, Professor Jørn Vatn, also played a key role in this research.

The readers of this report should have some basic knowledge in maintenance engineering principles, fundamental physics and stochastic processes. Two peer-reviewed papers form part of this report. As a whole, the report represents my main research achievements during my MSc study. The theories and models developed in the report/papers were based on other existing theories and models. You should pay attention to the common aphorism often attributed to the famous statistician, George Box, who was quoted to have clarified his claims by saying, "All models are wrong, some are useful."

Trondheim, 29-Jul-2016

Douglas Okafor Chukwuekwe

Acknowledgements

I am grateful to my supervisor, Associate Professor Per Schjølberg, who provided useful insights while guiding me in this thesis. I am equally grateful to my co-supervisor, Mr. Tommy Glesnes, for his contributions and support through his wealth of experience and loads of study materials and training manuals provided for this research. I am grateful to the staff and management of Karsten Moholt AS for contributing their facility and resources to aid the successful completion of this report.

Prior to this final report I extracted a paper which was peer-reviewed and accepted for presentation at the Euro Maintenance Conference 2016. The RAMS group offered me a grant to attend the Conference in Athens, Greece. I wish to thank Professor Jørn Vatn for all his moral support and for facilitating the department's financial support for my research and conference participation. I also wish to thank the European Federation of National Maintenance Societies (EFNMS), with special thanks to Mr. Cosmas Vamvalis, the Chairman and CEO of the EFNMS for his encouragement during the process. A second peer-reviewed paper based on this thesis has been accepted and would be presented at the International Conference on Maintenance Engineering (InCoME), August 2016 at the University of Manchester, UK.

I gained lots of inspiration from Marvin Rausand (Professor emeritus), I remain grateful to him and all the other professors who taught me at the NTNU in the course of this MSc study.

After thirteen years of completing my bachelor's degree, an industry work experience of twelve years, and five years of marriage blessed with two children, the decision to come to the NTNU (arguably one of the best technical universities in Europe) for my master's degree was always going to be a tough call. I am to that end profoundly grateful to my loving wife, Amaka, and our lovely children, Royal and Honour, for their understanding and support throughout this challenging episode.

I would like to thank my friends, colleagues and members of the Overcomers' Chapel International for their numerous assistance.

And, ... to my parents *Maazi na Lolo Moses & Mary Ani (in memoriam)*.

God bless you all!

Summary

As organisations strive to reach their production targets there are assets that are critical to their operations. The reliability and availability of these critical assets directly impact the profit margins of the organisations and by implication their continued existence. Within an organisation's maintenance function, predictive maintenance techniques such as condition monitoring and prognosis have today gained an increased attention because they are important to balance the dilemma between maintenance costs and technical acceptability. The level of competence and success recorded with the vibration based condition monitoring techniques means that they have found useful applications within varied industries from aerospace to manufacturing as well as the oil and gas industry in recent times.

However, as the transition is made away from traditional manufacturing and standalone systems, a major concern expressed within the industry is that the current approach presented within Industry 4.0 (the Industrial Internet of Things (IIoT)) for implementing predictive maintenance places too much emphasis on low level data monitoring to a degree that compromises the level of competence already achieved within the industrial application of vibration based condition monitoring, and there is so far no proven method to overcome the challenge.

The ultimate goal of any condition monitoring system is to gain capability to predict the future of the equipment monitored. Such a goal would be hard to reach by simply monitoring low level data such as temperature and pressure as currently suggested in the literature related to Industry 4.0 although there are still not many publications available in this area. The Industrial Internet of Things is a new and evolving paradigm, therefore research and implementation are still in their formative stages. Previous publications are quick to highlight the strategic importance of big data but fail to demonstrate how it can be organised and analysed for the purpose of predictive maintenance and for completing the maintenance decision loop. From the perspective of maintenance, the obvious weakness in the present big data exists in the fact that they are collected mainly for operational reasons and only serve maintenance purposes often "accidentally" or as an afterthought at the best.

In this thesis, investigations have been carried out and the results reported can bridge some of the existing gaps. Using vibration monitoring of rotating equipment as a case study, it was

demonstrated that the next generation of condition monitoring can integrate well into the Industrial Internet beyond low level data monitoring which is currently the case. It was shown that the application of a systematically selected stochastic process to low level data provides the required scaling up of vibration data to produce a more realistic and more practicable solution compared with any existing technique for the implementation of predictive maintenance within the Industry 4.0 environment. Machine generated real data and an industry grade software were deployed to obtain results which are not only compatible with the proposed Industry 4.0 reference architecture but also show a higher level of service when utilising the proposed condition monitoring technique. Using modern sensors and instrumentation techniques, vibration data is collected in a structured manner for the main purpose of predictive maintenance. The collected data is dimensioned and treated in a form compatible with Industry 4.0 requirement for single value data while retaining the original properties of vibration data. It was proposed to capture multiple snapshots of vibration patterns to which a single average value is assigned to the frequency spikes for every successive and corresponding time horizon. These values are aggregated over time and a regression is run adopting the technique of the autoregressive moving average (ARMA) to predict future failures. This is essentially a machine learning model that follows the propagation of an existing degradation over time and then estimates a future time when the degradation is beyond a predefined threshold. This gives room for planning and arranging for logistics in advance to minimise or totally avoid downtime.

Hence this new approach is expected to radically redefine the use of vibration based condition monitoring techniques within the Industrial Internet of Things without any loss of fidelity in its application to predictive maintenance and thereby ensuring safe cost reduction and the optimal utilisation of asset value. It is expected that the proposed solutions are refined further through collaborative efforts of researchers and the end-users in the industry.

Recommendations

The concept of end-of-life or remaining useful life prediction is not an easy technique. The challenges listed in this section are not exhaustive but they help to highlight the difficulties encountered in predictive maintenance applications. Integrating this into the new and evolving paradigm referred to as Industry 4.0 or more generally the Industrial Internet of Things (IIoT) can be very challenging as well. This thesis is valuable for future research, the following recommendations are hereby made for further investigation:

- The aspect dealing with lifetime modelling faced the challenge of incomplete observation, a term generally referred to as censoring and data truncation. It is necessary to investigate better ways to handle this problem that would lead to a more robust lifetime model.
- In order to derive full benefits from the vibration based condition monitoring of rotating equipment, the vibration signature should be analysed for its descriptive accuracy, diagnostic powers and prognostic capabilities. Diagnosis was not adequately covered in this study. Researching different imaging techniques and computer vision systems would enhance the results when integrated into the machine learning algorithm for the IIoT.
- The quality of data used affects the final results, it is important to research more advanced and more compatible signal processing and instrumentation techniques.
- Integration of predictive maintenance capabilities from an early design phase in future products and in future production lines. Industry 4.0 implementation pays attention to both products and production equipment because the product of one company could be the production equipment of another company.
- By design, robustness and resilience of products and production assets must address issues of cyber security, activities of criminal hackers and unethical competitors. Advanced encryption techniques should be investigated and comprehensive risk assessment must be carried out to establish the links between individual risks and the possible consequences.
- Further research is required to address the needs of standardisation, interoperability, open systems applications, and adaptability.

Structure of the Report

This master thesis has two main parts:

- **Main report:** this is the main part of the report. It covers the background, the problem description and thesis objectives. It includes the research methodology, the main results, discussion, recommendations and summary.
- **Papers/articles:** This part includes two peer-reviewed papers written and presented at international conferences. This is in fulfilment of one of the thesis' sub-objectives to present at least one paper at a reputable International conference. The articles are undergoing further review for publication in scientific/technological journals. These articles document my main research achievements during the MSc programme. They are related to the theme of this thesis and the specialisation project completed earlier during the Autumn semester of 2015.

List of Papers

Paper 1:

Reliable, Robust and Resilient Systems – Towards Development of a Predictive Maintenance Concept within an Industry 4.0 Environment

Paper 2:

Condition Monitoring for Predictive Maintenance – Towards Systems Prognosis within the Industrial Internet of Things

Contents

Preface	i
Acknowledgements	ii
Summary	iii
Recommendations	v
Structure of the Report	vi
List of Papers	vii
1 Introduction	1
1.1 Background	1
1.2 Objectives	2
1.3 Limitations	3
1.4 Approach	4
1.5 Structure of the Main Report	4
2 A Review of Maintenance Philosophies: Ancient and Modern	6
2.1 Corrective Maintenance	7
2.2 Preventive Maintenance	8
2.3 Predictive Maintenance	9
2.4 Condition Based Maintenance (CBM)	11
2.5 Reliability Centred Maintenance (RCM)	12
2.6 Failure Modes, Effects and Criticality Analysis (FMECA)	14
3 Fundamentals of Vibration Analysis and the Lifetime Models	16
3.1 Fundamentals of Vibration Analysis	16

3.1.1	The Root Mean Square (RMS) Value	18
3.1.2	The Fast Fourier Transform (FFT)	20
3.2	Lifetime Models	21
3.2.1	Parametric Families of Lifetime Distribution	22
3.2.2	Non-Parametric Families of Lifetime Distribution	24
3.2.3	Case Study: Analysing the Ball Bearings Failure Data	26
4	Rotating Machines Prognostics: The Science & Art of Vibration Technique	29
4.1	Mechanical Vibration and the ISO 10816 and ISO 7919	30
4.1.1	ISO 10816 (Parts 1 and 3)	30
4.1.2	ISO 7919 (Parts 1 to 5)	32
4.2	Frequency Peaks as Discrete Values	32
4.3	The Autoregressive Moving Average (ARMA) Models	36
4.4	Case Study: Implementing System Prognosis with the Thruster Gearbox Bearing Spectra	37
5	A Business Case Study for PdM: The Karsten Moholt Experience	42
6	Smart Maintenance: Interfacing Vibration Data with the IIoT	47
6.1	Computerised Maintenance Management System (CMMS)	48
6.2	Machine Learning and M2M Communication	50
6.3	The Industry 4.0 and its Key Enabling Technologies (KETs)	50
6.4	Smart Maintenance in the Context of Industry 4.0	55
7	Discussion and Conclusion	58
7.1	Discussion	58
7.2	Conclusions	60
A	Acronyms	61
B	Figures from the ISO 10816-1:1995(E) and Karsten Moholt	66
B.1	General form of vibration velocity acceptance criteria	66

B.2 Comparison of vector change and change in magnitude for a discrete frequency component 66

B.3 Vibration analysis flow chart 66

Bibliography **70**

Resume **75**

List of Figures

2.1	Maintenance Overview (Adapted from the maintenance terminology standard, EN-13306 (2010))	7
2.2	The bath tub curve for machine wear (wear rate indicates failure rate)	9
2.3	The P-F Curve (The Figure depicts the three maintenance philosophies described in the report. PM is a naive maintenance activity carried out at some conservative and arbitrary point "2" where the machine condition still has a high survival probability. The PdM/CBM is implemented to prevent the machine from reaching point "F" unexpectedly. After point "F" a functional failure has occurred and corrective maintenance is initiated to restore the lost function. Note that point "1" is not necessarily related to the age of the machine.)	10
2.4	Maintenance Task Assignment/Decision Logic Vatn (2007)	13
3.1	Time Waveforms, Frequency Spectrum and the Fast Fourier Transform	19
3.2	Ball Bearings	25
3.3	Minitab Output for the Ball Bearings Failure Distribution ID Plot (The Figure shows that the lifetime distribution model assumed for an analysis will influence the results. The MTTF estimates for example gave slightly different values across the distribution models.)	28
4.1	Points for Measuring Vibration	31
4.2	Spectral Patterns for Parallel/Angular Misalignment of a Shaft Rotating at the Shaft Rate Frequency "1X".	33

4.3 Forcing Frequencies and Frequency Peaks in Spectrum (The Figure shows three simple sinusoidal waveforms from the shaft, blades and coils combining into a complex overall vibration signal. When the FFT is applied to the complex vibration signal, the frequencies are separated into their respective peaks, note: 55 Hz for the shaft (corresponding to "1X"), 220 Hz for the Coils (corresponding to "4X") and 385 Hz for the blades (corresponding to "7X.")) 35

4.4 Waterfall Plot of Spectra from Different Survey Periods (The Figure is a screen shot from the Omnitrend software analytical tool used for this thesis courtesy of Karsten Moholt AS. It shows the spectra from survey periods indicated by date. 5 peaks occurring between 250 Hz and 300 Hz were averaged to smoothen the data's variability) 38

4.5 First Order Linear Regression of Vibration Severity/Peaks (The Figure shows an insert of the final tables used to implement first order linear regression on the vibration severity data. The model for predicting next period vibration severity is derived and shown. The line fit plot gives an indication of how the predicted and observed values match each other. The model is valid as the p-value is less than 0.05.) 40

5.1 A Thruster's Pinion Bearing and Rollers show extensive damage: a confirmation of an earlier vibration analysis carried out by Karsten Moholt predicting the damage 45

6.1 A Screen Shot of a CAMP System Input Window 49

6.2 Collaborative Interactions within the Smart Factory (from Kagermann et al. (2013)) 51

6.3 The Smart Maintenance Concept 56

B.1 General form of vibration velocity acceptance criteria 67

B.2 Comparison of vector change and change in magnitude for a discrete frequency component 68

B.3 Vibration analysis flow chart 69

List of Tables

- 3.1 Conversion Table for Harmonics Vibration 18
- 3.2 Millions of Revolution to Fatigue Failure for 23 Units of Ball Bearings 27

- 5.1 Machines and the Suitable CM Technologies for Defects Identification (adapted from the Mobius Institutes' Category I Vibration Training Course Book) 43

Chapter 1

Introduction

Maintenance is one of the most elusive subjects in the modern business enterprises. Whereas the concept has evolved over the decades, there are still many grey areas with some business executives still viewing the maintenance function with the suspicion of being a necessary evil. As we approach the 4th industrial revolution, the situation becomes more challenging with the promise of interconnecting many machines in an interdependent system of networks. This thesis focuses on the novel aspect of predictive maintenance within such collaborative networks. This chapter lays out the background to the tasks answered in this report, specifies the project's problem description and its objectives. The limitations of the report are presented, the approach is described and the structure of the main report is outlined.

1.1 Background

Competition between businesses is driving both cost and innovation. Companies want to do business at minimal costs and thus often adopt innovative technologies as a part of the strategy to reach their long term goal. As maintenance is a major cost element in any organisation's balance sheet, any solution with the possibility to reduce maintenance costs is often actively pursued. One of such maintenance strategies is predictive maintenance. The [EN-13306 \(2010\)](#) defines predictive maintenance as *"condition based maintenance carried out following a forecast derived from repeated analysis or known characteristics and evaluation of the significant parameters of the degradation of the item."* Several researchers have investigated condition monitoring

as a key maintenance activity necessary for the implementation of predictive maintenance on production assets. What is common between these researchers is their utilisation of the optimisation model to achieve their objective functions, [Rausand and Vatn \(2008\)](#), [Wang \(2008\)](#), [Schef-fer and Girdhar \(2004\)](#). The gap between existing optimisation models' theories and practice will increase as systems become more complex within the Industrial Internet of Things (IIoT). So far, there is no proven technique to bridge this gap.

This thesis uses condition monitoring of rotating machinery (by means of the vibration technique) as a case study. As discussed in [Lu et al. \(2009\)](#) and [Márquez et al. \(2012\)](#), the vibration based condition monitoring has a proven track record in wind turbines as well as other rotating equipment applications. However, at the dawn of Industry 4.0 [Kagermann et al. \(2013\)](#), [Evans and Annunziata \(2012\)](#), a major concern expressed by my industry partner in this thesis is that there is a high chance of loss of fidelity in the representation of vibration data. The reason is that under current Industry 4.0 propositions, focus is on monitoring low level data such as temperature, pressure, flow rate, vibration root mean square (RMS) values, and so on. On the contrary, the success of the vibration based condition monitoring is derived from its capability to handle a multiple dimension of data from time waveforms, frequency spectra and phasors. The vibration signature is analysed not just as a science but also as an art and the outcome is used for maintenance decision support. With an improved data representation technique and the application of smart machine learning algorithms within the sphere of the IIoT, the science aspect of the data analysis can be overcome but the art part is intractable because it is based on human experience, intuition and subjective reasoning. Rotating machine prognostics is discussed in a greater detail in chapter 4 and in chapter 6 it was argued that an efficient integration of vibration data with the IIoT is an irreducible minimum for smart maintenance, chapter 5 provides the cost benefits for implementing predictive maintenance.

1.2 Objectives

The main objective of this master thesis is to present how predictive maintenance can be used for prognosis by relying on the vibration based condition monitoring of rotating machinery while recording data in an Industry 4.0 compliant manner. The peer-reviewed conference pa-

pers presented in the course of this thesis and master programme are integrated into the objective of the study. The main objective is achieved by performing the following tasks which form part of the thesis sub-objectives:

1. Identify and clarify the main maintenance philosophies applied to production assets, state the key underlying assumptions and the pros and cons associated with each.
2. Discuss the fundamental basis of the science for vibration analysis and present some general lifetime models.
3. Study how the vibration technique is used for rotating machinery condition monitoring and present how this can be used for diagnosis and prognosis – causes of failure and remaining useful life (RUL) prediction.
4. Provide a case study to justify the utilisation of condition monitoring on critical assets as a means to reduce costs safely.
5. Identify and present possible approaches and the benefits of integrating vibration data with the IIoT to achieve smart maintenance.

1.3 Limitations

This master thesis is time limited to twenty weeks based on the applicable rules at the university. The main audiences are college students, professors and members of the industry with some backgrounds in maintenance engineering theories and practice, rotating machinery, vibration analysis, data sciences and stochastic processes.

The IIoT is a new and evolving paradigm, literature in the area was scarce and hard to find. Only a limited amount of vibration data was available as a conscious effort was made to use actual measurements from real assets. Where the amount of available information was deemed insufficient or out of step with the desired format, certain assumptions and honest estimates were made and documented. Signal processing, programming and advanced instrumentation/automation techniques are beyond the scope of this report.

1.4 Approach

A review of relevant literature was carried out in order to reach the thesis sub-objectives. This approach was combined with theoretical research and case study to achieve the main objective. I worked with an industry partner, Karsten Moholt AS, to collect and analyse real vibration data and ran simulations using the Omnitrend software licenced to the company as well as the Minitab package licenced to the NTNU. Simulation results illustrated the validity of my argument and are expected to enhance readers' understanding. I visited the partner company to make personal observations and to interview experts. I followed the insights and informed recommendations made by my supervisor and co-supervisor while carrying out those tasks initially thought to be beyond my competence and availed myself of every learning opportunity provided throughout the process of completing this thesis.

1.5 Structure of the Main Report

The rest of the *main report* is organised as follows:

- Chapter 2 provides an overview of maintenance philosophies and clarifies related terminologies;
- chapter 3 covers the fundamentals of vibration analysis and introduces some illustrative lifetime models;
- in chapter 4, the vibration based condition monitoring methodology is described in detail and the autoregressive moving average (ARMA) technique is used to support machine learning capability for a rotating equipment prognosis;
- chapter 5 presents a case study using real data to highlight the importance of predictive maintenance as a safe cost cutting mechanism;
- chapter 6 discusses the necessary approaches and the requirements to interface vibration data and the IIoT, that is to provide the basis for smart maintenance application within Industry 4.0;

- and chapter 7 presents a discussion of the main results and concludes the report with some insights.

Chapter 2

A Review of Maintenance Philosophies: Ancient and Modern

The maintenance terminology standards ([EN-13306 \(2010\)](#)) defines maintenance as *“the combination of all technical, administrative and managerial actions during the life cycle of an item intended to retain it in, or restore it to, a state in which it can perform the required function”*. Maintenance management on the other hand determines the maintenance objectives, strategies and responsibilities, execution of consciously selected action plans to meet the overall organisational and maintenance objectives. It was equally shown in [Wilson \(2002\)](#) that effective maintenance means carrying out tasks at the right time with both speed and skill. When discussing maintenance theory it is necessary to clarify the terminology, structure and objectives of different maintenance philosophies. In a broad sense, three maintenance practises, namely corrective maintenance, preventive maintenance, and predictive maintenance are discussed in this chapter. The three broad categories of maintenance philosophies presented were further linked with other maintenance concepts such as condition based maintenance (CBM), reliability centred maintenance (RCM), reactive, proactive and precision maintenance. Figure 2.1 provides an overview. The average percentages of the different maintenance types shown, based on data available from industry, indicates that more than 55 percent of all maintenance related activities fall within corrective maintenance and that means that more than half of the times, maintenance activities happen as a surprise to maintenance managers with its natural consequence of suboptimal value realisation on physical assets. A well structured predictive mainte-

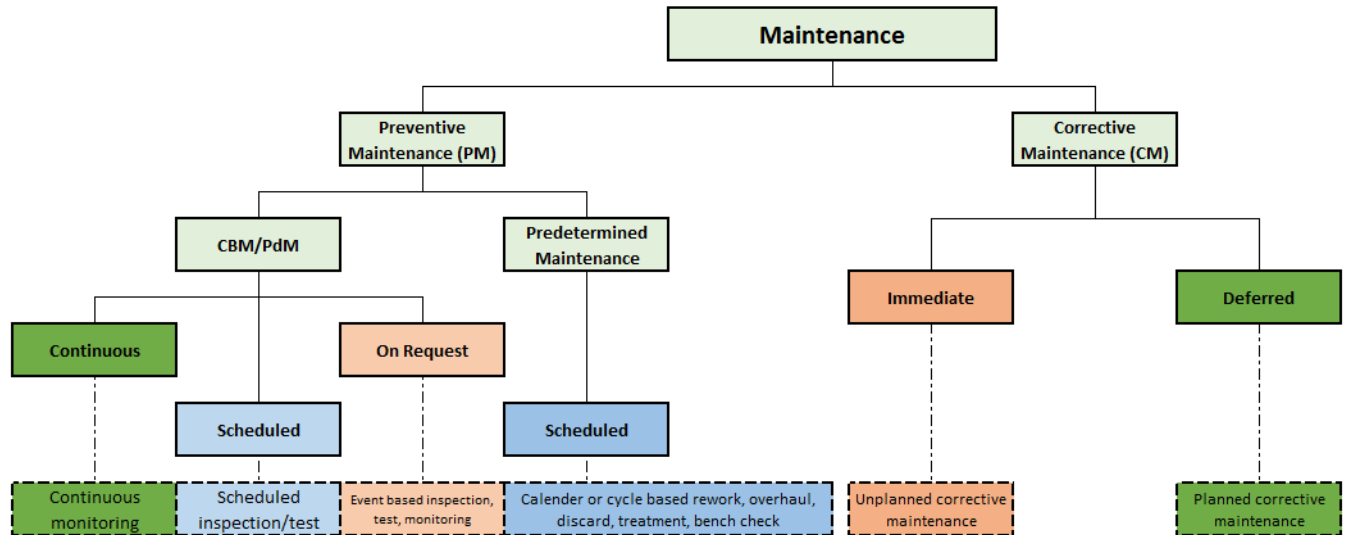

Figure 2.1: Maintenance Overview (Adapted from the maintenance terminology standard, EN-13306 (2010))

nance system is important to avoid unplanned stops or mitigate the consequences of sudden failures. Increasing the percentage of CBM driven maintenance activities from its current 12 percent level (as per industry survey) will have a direct positive impact on the safety and profitability factors of maintainable assets.

2.1 Corrective Maintenance

The philosophy here is "fix it when it breaks." Other terms used to refer to corrective maintenance are run-to-failure (RTF), breakdown maintenance, hysterical or reactive maintenance, and so on [Wilson \(2013\)](#), [Zaal and Newton \(2011\)](#), [Mobley \(2002\)](#). It is not wrong just because it is reactive maintenance; there are a few instances where corrective maintenance might be viable, what is important is to have a due consideration to the maintenance and organisational goals. In other words, define your objectives. Pay attention to the asset criticality. Answer the question, "how does the failure of a machine affect my production?" And other related questions, "how does a sudden loss of an essential function affect the organisation's overarching objectives?" "What are the important safety or cost considerations to drive maintenance policy?" "How does a breach affect the maintenance department's reputation or the organisation's profitability?"

Rather than carefully anticipating and planning in advance for events, reactive maintenance is a fire brigade approach. Generally speaking, running a production asset primarily based on reactive or corrective maintenance mode is not the right way to do business today. This is because a production facility run in this way always finds itself merely reacting to situations and trying to catch up with stakeholders' expectations. It is important to take advantage of technology and more sophisticated maintenance processes to achieve better results.

2.2 Preventive Maintenance

In order to prevent a maintainable asset from failing, reduce the probability of loss of function or attain a reasonable level of dependability it requires the performance of certain maintenance tasks, given that the item is used within its intended design. Other terms commonly used to refer to preventive maintenance (PM) includes scheduled or predetermined maintenance, historical, calendar or cycle based maintenance, *inter alia*. The maintenance tasks performed before an asset enters a failed state is referred to as preventive maintenance [Rausand and Høyland \(2004\)](#), [Scheffer and Girdhar \(2004\)](#). The guiding theory of the PM philosophy is to "fix it before it fails." The underlying assumption thus is that every machine will suffer certain amounts of degradation as it ages in operation and will eventually fail with time and/or use.

Predetermined maintenance is a preventive maintenance activity carried out on hard time basis by assigning lifetime distributions to components based on assumptions or experiments. Typically, the facts of these assumptions are observations carried out on another related component. The current maintenance activity is "called out" based on that historically documented information but without any recourse to the actual performance of the item, it does not matter whether the item is presently functioning or is in a failed state, it has to be discarded, serviced or overhauled so long as the predetermined interval has been attained. Predetermined maintenance is not proven to be founded on sophisticated technology or procedure. It is often criticised for being a wasteful maintenance philosophy. It has become less popular over the last decades. The rising popularity of smart sensors and advanced instrumentation techniques mean that the advantages of condition based maintenance have become more obvious. Another disadvantage of PM as proven by [Okoh and Haugen \(2013\)](#) is that maintenance activities

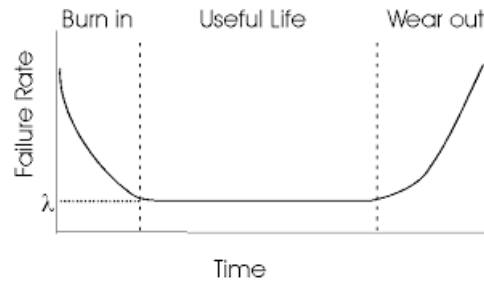

Figure 2.2: The bath tub curve for machine wear (wear rate indicates failure rate)

can lead to failure due to human error or infant mortality, for example. The region marked as "burn in" in Figure 2.2 represents the infant mortality events. That is why it is important to perform maintenance only as required, that is, based on actual condition of the equipment under consideration and not just historical deductions.

2.3 Predictive Maintenance

Predictive maintenance is predicated upon the philosophy: "if it is not broken, don't fix it." Rotating machines typically show signs of impending failure before the occurrence of an eventual breakdown if appropriate actions are not taken timely. For example, there could be an increase in temperature or cracks in the hot sections, rise in vibration level, or change in vibration spectral patterns and time waveforms. There might be a drop in performance, an increased noise level, increased rotor stiffness, or changes in motor currents and voltages amongst several other signs. There are many techniques in use today that can provide early signs of these degradation modes [Chukwuekwe et al. \(2016\)](#). The spectrometric oil analysis programme (SOAP) can detect the erosion of metal surfaces in aircraft engines by analysing the lubricant. Improper lubrication, rotating members' imbalance and excessive play are common causes of component wear in machines especially among mating members or metals in contact. Vibration analysis which is discussed in detail in this report (see chapters 3, 4 and 6) can provide early warning indications and help detect these failure mechanisms before they reach an alarming level. Predictive maintenance is the systematic application of these condition based early warnings to the maintenance of the production assets under consideration. A system that provides an early sign of failure helps to mitigate surprises. Maintenance activities and repair works are planned in ways

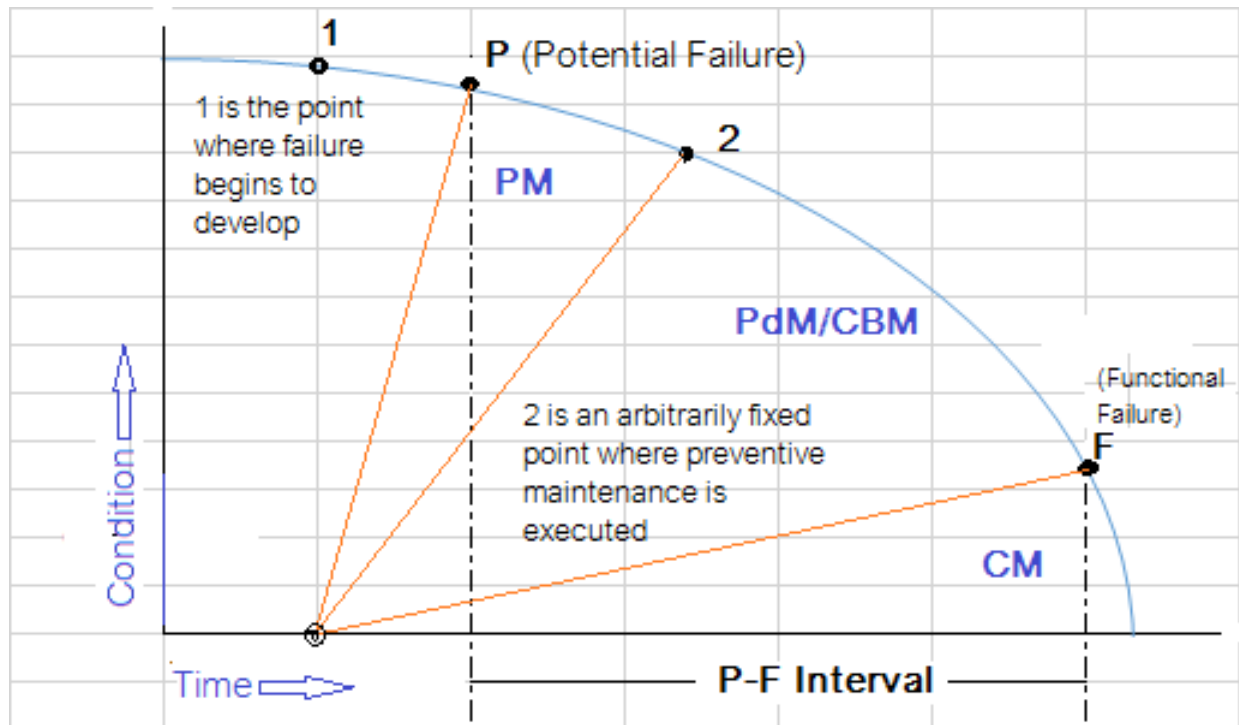

Figure 2.3: The P-F Curve (The Figure depicts the three maintenance philosophies described in the report. PM is a naive maintenance activity carried out at some conservative and arbitrary point "2" where the machine condition still has a high survival probability. The PdM/CBM is implemented to prevent the machine from reaching point "F" unexpectedly. After point "E," a functional failure has occurred and corrective maintenance is initiated to restore the lost function. Note that point "1" is not necessarily related to the age of the machine.)

that consider not only maintenance needs but also production schedules. Ideally, there will be a higher machine availability, increased profit, lower cost of holding inventories of spare parts and a drastically lower maintenance costs. Predictive maintenance is more than just condition monitoring. It involves changes in maintenance philosophy orientations and management procedures to allow maintenance activities to be triggered by real maintenance needs rather than carrying out maintenance based on what time it is on the manager's clock or calendar. Figure 2.3 provides an additional insight into the three major maintenance philosophies with respect to the P-F interval.

2.4 Condition Based Maintenance (CBM)

The EN-13306 (2010) defines condition monitoring as *any activity or set of activities, performed either manually or automatically, intended to measure at predetermined intervals the characteristics and parameters of the actual state of an item*. One of the main application areas of the CM technique is in condition based maintenance (CBM). CBM is a preventive maintenance which includes a combination of condition monitoring and/or inspection and/or testing, analysis and the required maintenance actions. These activities may be scheduled, on request or on a continuous basis. The principal objective of the CBM technique is that the condition of the asset is the driver for its maintenance Zaal and Newton (2011). In order for condition monitoring and by extension condition based maintenance to be implementable, the following are necessary and sufficient preconditions to be met:

1. There must be a possibility to detect reduced failure resistance related to any identified failure mode
2. There must be a possibility to unambiguously define potential failure conditions that are detectable by systematic and explicit task(s)
3. The system is not prone to shock failures instead there is a reasonably consistent age interval or lapse of time between the potential failure and actual or functional failure. This is related to the concept of fault latency Simeu-Abazi and Bouredji (2006).

Rausand and Vatn (2008), Vatn (2007) and Mobley (2002) present a more detailed discussion on the concept of CBM.

It is necessary to highlight that condition monitoring only tells us the functional status of the machine and helps us to be able to plan in advance to respond to any maintenance demands, it does not help in any way to enhance the reliability of the machine or delay its failure (except if additional measures were taken). In other words, it helps to anticipate and meet maintenance needs before equipment breakdown. This is proactive maintenance, a term which also defines other strategies such as precision maintenance, root cause failure analysis and reliability centred maintenance. The term "proactive" is instructive because in that sphere, rather than just reacting to the impulse of a sudden failure, a conscious effort is made not only to predict and re-

spond to the possibility of a failure but also to address its root cause for the purpose of learning and to forestall future events. It is great to be able to use the CBM to identify failures before they occur but it is even more beneficial to dig into the roots of the failure causes and use that knowledge to improve the reliability of the machine. That leads to a new paragraph and a discussion on reliability centred maintenance.

2.5 Reliability Centred Maintenance (RCM)

Reliability Centred Maintenance (RCM) is a method for maintenance planning developed in the sixties within the aviation industry and later adapted to other industries and military departments [Rausand and Vatn \(2008\)](#). The logic of an RCM analysis as a maintenance management method is to use the failure mode/failure cause in the *Failure Modes, Effects and Criticality Analysis* (FMECA) to establish ways by which the appropriate maintenance actions can be used to overcome failures or degradation tendencies in an asset.

As pinpointed by [Vatn \(2007\)](#), the main objectives of RCM analysis are:

- Identification of effective maintenance tasks;
- Evaluation of the identified tasks by performing some cost–benefit analysis, and
- Preparation of a plan for carrying out the identified maintenance tasks at optimal intervals.

Figure 2.4 shows a typical application of RCM analysis in maintenance task assignment leading to a scheduled function test (SFT) [Vatn \(2007\)](#).

The basic assumption of the RCM analysis is that every machine has a limited useful life and will eventually degrade to a failed state (P-F curve, ref. Figure 2.3). The absolute validity of these assumptions has been challenged by [Mobley \(2002\)](#) who argues that if a physical asset was properly designed; installed, operated and maintained the right way, that asset can have a perpetual availability and an endless life except for a few random failures or external factors such as an operator error.

The RCM analysis is not a quantitative method [Vatn \(2007\)](#) and thus cannot be used to determine an optimum maintenance interval. Professors Rausand and Vatn identified 12 steps

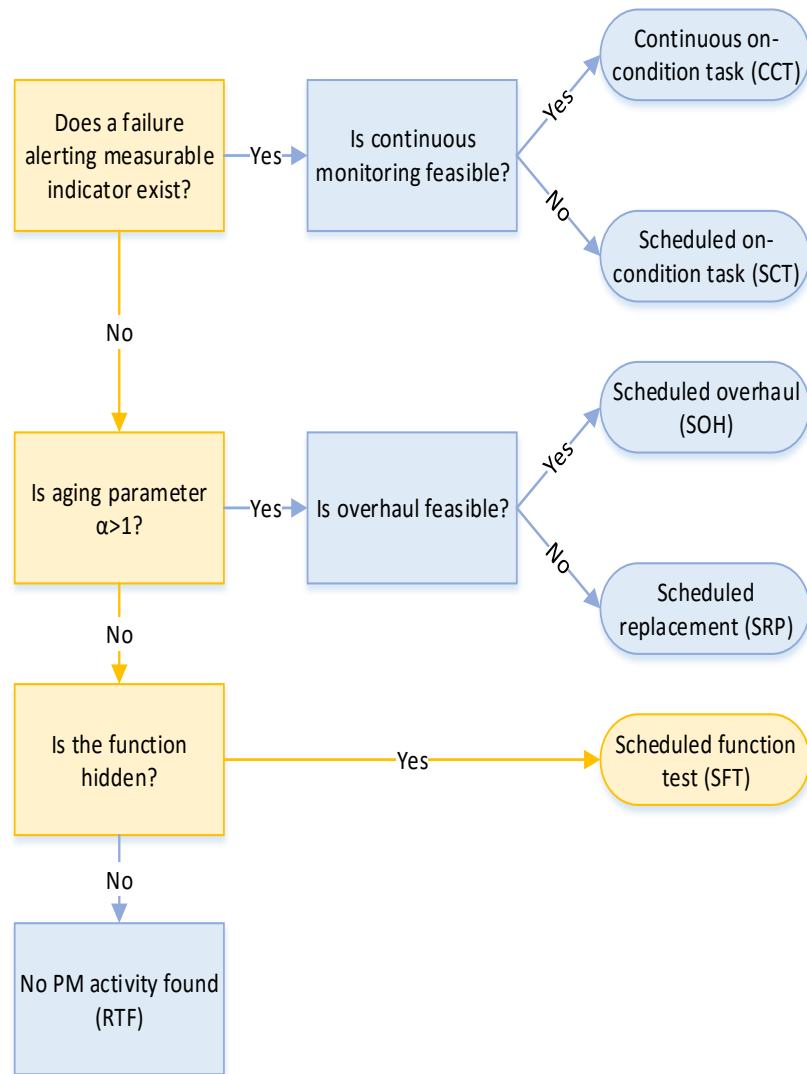

Figure 2.4: Maintenance Task Assignment/Decision Logic Vatn (2007)

for carrying out the RCM analysis some of which are: identification and selection of systems, Functional Failure Analysis (FFA), selection of critical item(s) or maintenance significant items (MSI), collection and analysis of data, FMECA, selection of maintenance actions, maintenance interval determination, and in-service data collection and updating [Rausand and Vatn \(2008\)](#). The reliability centred maintenance is in many respects a classical example of proactive maintenance tool. It incorporates, at some stages, certain aspects of root cause analysis and the failure modes and effects analysis, for example.

2.6 Failure Modes, Effects and Criticality Analysis (FMECA)

Predictive maintenance requires condition monitoring on the components and systems that make up a production plant. It is however both costly and unrealistic to monitor every single piece of item in complex production plants. The FMECA provides a technique to select the components or systems with the highest importance while prioritising for the predictive maintenance applications. FMECA is a semi quantitative (often, bottom-up) analysis used to assess what effects the failure of particular components will have on the functioning of the whole system as designed [Rausand \(2014\)](#), [Rausand and Vatn \(2008\)](#). The FMECA is often adapted as a part of RCM activities and has proven use in functional failure identification and maintenance significant item (MSI) categorisation. The FMECA is a good first step for reliability engineers to estimate system structures and parameters such as mean time to repair (MTTR), mean time to failure (MTTF), mean time between repair (MTBR), failure rate or force of mortality (FOM), among others. It is used to identify components or systems with significant importance to be placed under condition monitoring or to draw up preventive maintenance strategy.

Experience with the application and use of the FMECA technique has proven that the use of the so-called TOP event (a term associated with fault tree analysis (FTA) as a basis for the analysis can significantly simplify the analysis and make the workload less cumbersome. The TOP event may be defined, for example, as safety, system availability, environmental hazard, punctuality, production loss or an accident. By considering an applicable TOP event in a consequence analysis, the FMECA finds useful application in the barrier model for safety as shown in the Swiss cheese model by [Reason and Reason \(1997\)](#) to balance production and protection.

Several published standards and procedures provide useful guidance and a more detailed information on how to conduct the FMEA/FMECA [MIL-STD-1629A \(1980\)](#), [MIL-STD-2155 \(1985\)](#), [IEC-60812 \(1985\)](#), [BS-5760-5 \(1996\)](#), and [SAE-ARP-5580 \(2001\)](#).

The current chapter provides a review of some relevant maintenance concepts and philosophies. The discussion is by no means exhaustive but a motivation was provided as a basis for understanding the applications presented in later chapters. It is also intended in parts to answer the question, "why is maintenance important?" and "why is it necessary to consider production concerns while scheduling maintenance?" The latter question form part of the issues addressed with predictive maintenance. Other challenges that could be overcome by following effective maintenance philosophies were also highlighted. The key objectives include reliability growth and improvement, energy and resource efficiency, maintenance costs reduction, improved product quality, optimised asset value and increased profitability.

Chapter 3

Fundamentals of Vibration Analysis and the Lifetime Models

Whilst there is an increased focus on big data, it has been noted that most organisations do not have a proven system for running data analytics and getting the best out of the prevalent big data. The reason is often that the industry has not done enough to integrate stochastic processes into their maintenance decision models. This chapter introduces the fundamentals of vibration analysis and proposes how the data generated can be treated with existing statistical methods. A few practical interpretations are provided to illustrate the discussion.

3.1 Fundamentals of Vibration Analysis

Production facilities are replete with rotating and reciprocating machines. For that reason, vibration based condition monitoring is arguably the most popular technique in the industry today. It is used to give an indication of system malfunction by measuring vibration signals [Wang \(2008\)](#). The two important quantities often measured are frequency and magnitude of vibration. The displacement, velocity (often the preferred choice) and acceleration parameters are related to one another and are representations of magnitude [Mobley \(2002\)](#). Vibrations are measured in time domain and then converted to the frequency domain by means of frequency analysers for example the mathematical algorithm known as Fast Fourier Transform (FFT) analysers.

If we consider vibration as our *monitored quantity* to be periodic and about an equilibrium

position then we can make a prediction based on the laws of physics. If T is the period of vibration, $V(t)$ its velocity measured at time, t then the *root mean square (RMS)* value of this velocity is proportional to the *vibration energy* given as:

$$V_{\text{rms}} = \sqrt{\frac{1}{T} \int_0^T V(t)^2 dt} \quad (3.1)$$

it follows that the average value is given as:

$$V_{\text{avg}} = \frac{1}{T} \int_0^T V(t) dt \quad (3.2)$$

and the fundamental frequency,

$$f = \frac{1}{T}$$

By following the Laws of Physics, we define the crest factor as

$$F_c = \frac{V_{\text{peak}}}{V_{\text{rms}}}$$

and the form factor as

$$F_t = \frac{V_{\text{rms}}}{V_{\text{avg}}}$$

If we assume that the vibration function $V(t)$ under investigation is sinusoidal, then

$$V(t) = V \cdot \sin(\omega t) \quad (3.3)$$

which returns the following values:

$$V_{\text{peak}} = V$$

$$V_{\text{avg}} = \frac{2V}{\pi} = 0.636V$$

$$V_{\text{rms}} = \frac{V}{\sqrt{2}} = 0.707V$$

$$F_c = \sqrt{2} = 1.414$$

$$F_t = 1.11$$

Table 3.1: Conversion Table for Harmonics Vibration

From	To	Peak to Peak	Peak	RMS	Mean
Peak to Peak Value		1.00	0.5	0.35	0.32
Peak Value		2.00	1.0	0.71	0.64
RMS Value		2.83	1.41	1.00	0.90
Mean Value		3.14	1.57	1.11	1.00

Table 3.1 (from [Rao \(1996\)](#)) provides a basis for converting peak-to-peak value to RMS value and vice versa. In modern vibration analysis systems, the RMS value is obtained automatically with the help of a special software but the discussion has been included here to provide a motivation to understand the physics behind the RMS value conversion. At Karsten Moholt AS, the software currently in use for vibration analysis is the "Omnitrend" developed by the German company, Prüftechnik.

3.1.1 The Root Mean Square (RMS) Value

The mathematical definition of RMS as shown in earlier equations is the peak value divided by the square root of 2, assuming a sinusoidal waveform. It is a measure of the average amount of energy contained in the vibration waveform. It is assumed that readers have basic understanding about simple harmonic motion, but as the RMS value is important for describing vibration data, this paragraph is dedicated to clarify the RMS terminology with respect to vibration analysis. The vibration data can be presented in a way that simply sums it up as a single number called "overall RMS or overall level." The procedure to organise and trend the aggregation of these single number overall values over a period of time can provide an indication of fault or deviation [Kuemlee et al. \(2013\)](#), [Lim et al. \(2010\)](#). By comparing these trended overall RMS values to a predefined alarm level it is possible to get an early indication of impending failure. What is common in practice is to capture and trend velocity readings. These readings are then referenced against some alarm charts (for example in ISO 10816-3 and ISO 7919-1). The idea is that when a mechanical fault is present in any component of the rotating machinery, the level of vibration will trend following an upward pattern. The alarm level is therefore selected to correspond to some upward value prior to what is predefined as a functional failure. When the mechanical fault leads to an amount of degradation that trends up to this predefined alarm

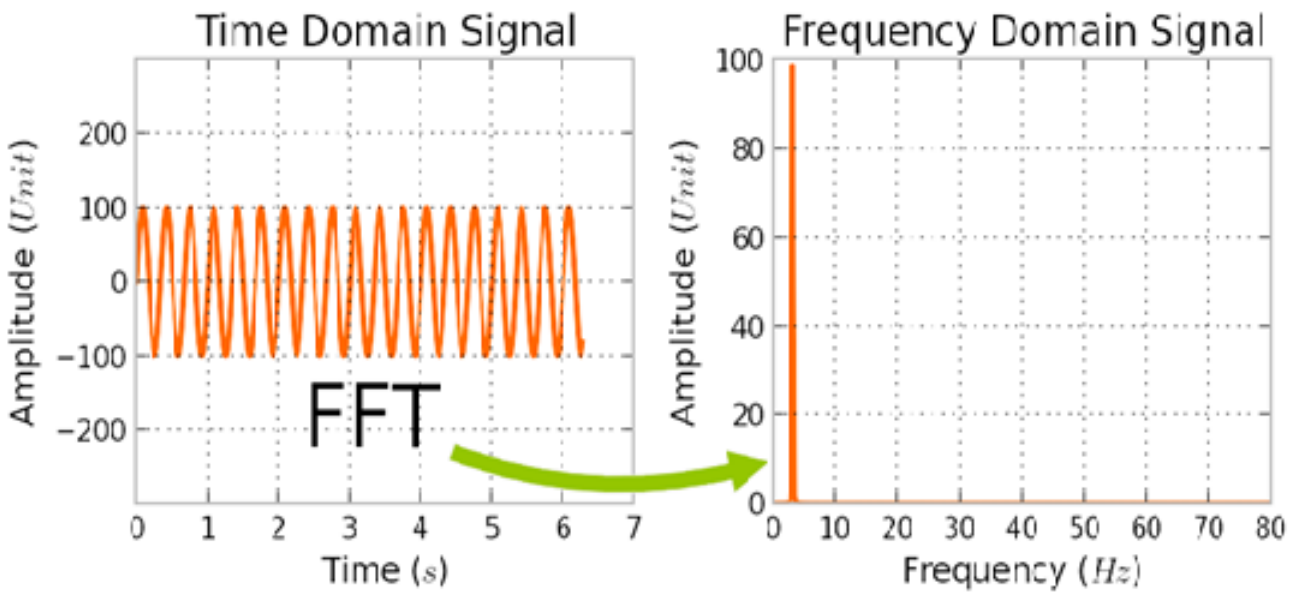
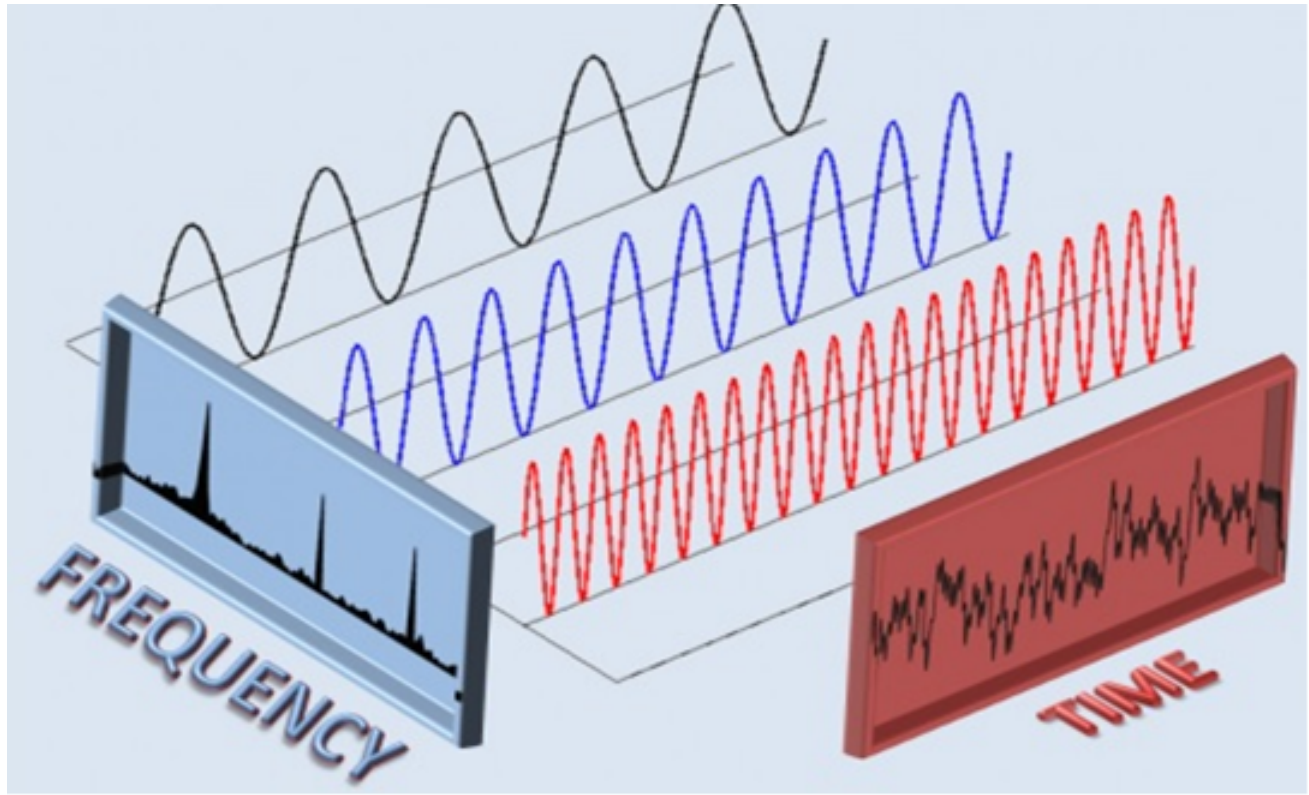

Figure 3.1: Time Waveforms, Frequency Spectrum and the Fast Fourier Transform

level, it creates the necessary awareness not only to use the machine with greater caution going forward but also to trigger the necessary planning process in order to carry out maintenance at a time conducive to the production demand of the plant. However, the approach to trend the RMS amplitude is rather unsophisticated and based on the experience at Karsten Moholt AS, it does not always produce the correct results. There were instances where faults could not be detected with the trended RMS values although the system was confirmed to have faults by other means. There were also examples of trended values showing signs of faults whereas there was none. The reason is that there are other factors that could cause mechanical faults not to manifest in the overall trend and the contrary is also true that some factors could cause the overall trend to increase which are totally unrelated to any mechanical faults. In order to make the measurements to be more robust, it is necessary to consider the frequency spectrum in addition to the time waveforms. The Fast Fourier Transform provides a technique to convert from time to frequency domain and vice versa (ref. Figure 3.1).

3.1.2 The Fast Fourier Transform (FFT)

The Fast Fourier Transform (FFT) is an important terminology in the discussion of rotating machinery vibration signal processing and the analysis of the resulting data. The upper part of Figure 3.1 shows a complex time waveform displayed on the red board. That sort of complex vibration signal often comes from multiple sources in a rotating machine: the prime mover or rotor, bearings, pulleys, gears, fan blades, and so on. These different components vibrate at different frequencies and amplitudes to create the complex waveform. In order to make use of the vibration signal for any practical purpose, there has to be a way, for example, to separate the vibration signal coming from the bearing from the one coming from the gear, and so on. That means we cannot directly analyse the time waveform and associate faults to any particular component. That challenge is overcome with the vibration spectrum and spectral analysis. The process for converting the time waveform into the frequency spectrum is called the Fast Fourier Transform (FFT). The left hand side of the upper part of Figure 3.1 shows the frequency peaks from the three sinusoidal waveforms that made up the complex time waveform on the right hand side. The FFT technique was used to separate the complex waveform which are then displayed on the blue board according to their individual frequencies. The lower part of the figure

shows a transformation from time domain (time versus amplitude) to the frequency domain (frequency versus amplitude) using the FFT. [McInerny and Dai \(2003\)](#), [Fessler and Sutton \(2003\)](#) are among a rich encyclopedia of materials written on signal processing and the role of the FFT in signal analysis.

In the context of Industry 4.0, what has been proposed in this report (see chapters 4 and 6) is to use the frequency peaks from the FFT spectral analysis as a basis for determining the extent of tolerable degradations and the setting of the alarm limits. Because these are single values, they are automatically compatible with the current proposals within Industry 4.0 for the use of single, discrete numbers. The sidebands and harmonics from the spectral analysis will also be modelled as single values and the data can be organised and treated together in a structured way using already well studied lifetime models and stochastic processes.

3.2 Lifetime Models

This section highlights the importance of data in machine health monitoring including activities related to prognosis or predictive maintenance [Lindqvist \(2006\)](#). The purpose is not to write an in-dept report on stochastic processes (such topics have been rigorously treated in the mathematical/statistical body of knowledge), instead a motivation is provided for understanding the basis for the lifetime distributions of maintainable assets. The concept of lifetime modelling is used to study how machine failures and the representative data are distributed over a time period. This essentially entails that data is first of all collected and further that a statistical model is fitted on the data or estimated for it. The emphasis is on the failure and maintenance data for repairable components such as ball bearings or systems such as rotating machinery. Depending on one of two approaches, we have either the parametric or the non-parametric families of lifetime distributions. Both are covered in many standard statistics textbooks. At the end of the chapter, the Minitab statistical software is used to test a standard data set from ball bearings. By observing and plotting the ball bearings failure data, four different lifetime distribution models were separately assumed. The results were compared with each other to help identify which models fit the data best. It was easy to see by inspection that the data set is best described by the lognormal distribution but in more complex cases a test is required. The Anderson-Darling's

goodness-of-fit is included in Minitab but can also be computed manually and may satisfy the requirement for such a test. The lower the Anderson-Darling goodness-of-fit value the better the assumed model fit the analysed data. The general focus is on the analysis of machine data for maintenance decision purposes not the statistical inferences. Equations and relationships between functions are stated in this report without any further proof.

3.2.1 Parametric Families of Lifetime Distribution

The lifetime, T of a machine component or system is a positive and continuously distributed random variable that can be modelled by its probability density function (pdf), cumulative distribution function (cdf), reliability or survival function, $R(t)$ and the hazard function, $z(t)$ often referred to as failure rate or the force of mortality (FOM). The parametric models make the assumption that the lifetime distribution of a machine data-set is characterised with a known parameter within some specific distributions such as the exponential, Weibull, Gumbel, normal, lognormal, logistics, log-logistics distributions among others.

For a lifetime, T the mean time to failure ($MTTF$) equals the expected lifetime $E(T)$, thus:

$$MTTF = E(T) = \int_0^{\infty} t f(t) dt = \int_0^{\infty} R(t) dt \quad (3.4)$$

If we further make the assumption that T is exponentially distributed, then its probability density function, pdf is given as:

$$f(t) = \lambda e^{-\lambda t}$$

Which results in the computation

$$MTTF = \frac{1}{\lambda}$$

The above equations hold true for the exponential lifetime distributions. λ is the failure rate. The practical implication of the MTTF being the reciprocal of the failure rate in an exponentially distributed lifetime is that the failure of such components is constant and does not depend on time. This is the so-called "memoryless" property of the exponential distribution. Another reason why the exponential distribution is popular with system reliability engineers is that it is easy to analyse, for example in the Markov chains and Markov processes. It is often used to

describe the times to failure of components that experience wear out after some expected time in service. Common examples are high grade integrated circuits and capacitors used in special applications such as space missions. If the criticality of components known to have exponential lifetime distributions permits, the most efficient maintenance policy would be to run such components till they fail and then a repair or replacement is carried out. There is a debate in the maintenance engineering community as to what state the system is restored after the failure event. Some are pessimistic and say that it is restored to the state it was immediately before it failed; whereas some are optimistic and argue that the system was renewed, in other words, it was restored to an as good as new condition. Maybe the true state after the so-called renewal process is somewhere between what the pessimists and the optimists postulate but so far there is neither a methodology nor a literature to point out where this compromise position might be.

The Weibull distribution is also another type of lifetime distribution that is studied very often by reliability and maintenance engineers. Unlike the exponential distribution, it is modelled with at least two parameters. The lifetime T of any component can be modelled as coming from a Weibull distribution with a *shape parameter* α and a *scale parameter* β (both α and β are greater than zero). It is shown in [Rausand and Høyland \(2004\)](#) that for a Weibull distributed lifetime, its survival function

$$R(t) = e^{-(\lambda t)^\alpha}$$

And the expected lifetime is computed as

$$E(T) = \int_0^\infty R(t) dt = \int_0^\infty e^{-(\lambda t)^\alpha} dt \quad (3.5)$$

The theory of extreme values provides an understanding that enables the Weibull distribution to be used to model the minimum of a certain class of distribution if the data-set represent a large number of independent positive variables. The extreme value could be the failure of the weakest link in a chain with each chain exposed to an independent failure mode such as stress or fatigue. It could also be the failure of a system which is comprised of a large number of components in series assuming that the failure mechanisms in the individual components are approximately independent. Above all, the greatest attraction of the Weibull distribution to engineers and system analysts is empirical. The Weibull distribution has been used to successfully model failure

data with either an increasing or decreasing failure rate. The Weibull regression model ([Attardi et al. \(2005\)](#)) also has the so-called proportional hazard property and it is the only log-location-scale-survival-regression model known to have this property. That means that the hazard rate is a product of two factors: one factor is a function of time but not of a certain covariate vector and the second factor is a function of a certain covariate vector but not of time. This is an important analytical technique when considering the concept of relative or competing risks. In the analysis of the failure of a rotating equipment, it may be necessary to answer the question of a particular component's failure resulting from the factors of fatigue or corrosion among other failure mechanisms.

The lognormal distribution ([Pascual and Montepiedra \(2005\)](#), [Peng and Tseng \(2009\)](#)) is the last of the survey of common distribution models discussed in this section to provide the motivation for using parametric models in data analysis. The lognormal distribution is widely considered to be an appropriate model for the times to failure when the failures result from degradation processes in a multiplicative combination with some random rates. This model has been used widely to describe the time to fracture resulting from fatigue crack propagation in metals. It is an important model to consider while carrying out vibration analysis of rotating equipment in the context of this report.

3.2.2 Non-Parametric Families of Lifetime Distribution

The non-parametric model is used when nothing is known about the distribution of the studied lifetimes or when the available knowledge is not sufficient to assume any lifetime model. However, it is often useful in practice for analysts to compare the results from the parametric and non-parametric models of the same data-set. The aim of the non-parametric technique is to estimate some of the functions earlier discussed under the parametric models: the probability density function (pdf), cumulative distribution function (cdf), reliability or survival function, $R(t)$ and the hazard function, $z(t)$. Two methods (the Kaplan-Meier Estimator and the Nelson-Aalen Estimator) used widely in the non-parametric technique for data analysis are presented below. [Lindqvist and Doksum \(2003\)](#) and [Lindqvist and Langseth \(2005\)](#) provide additional materials to aid the understanding of the basis for these estimation methods and other related topics.



Figure 3.2: Ball Bearings

The Kaplan-Meier Estimator

Assume that the lifetimes $T_1, T_2, T_3, \dots, T_n$ have a common survival function $R(t)$ and are independent and identically distributed. Consider also that the property of independent censoring was satisfied. By definition, the property of independent censoring is said to be satisfied in a censoring scheme, "if, at any time t , the components at risk are representative for the distribution of T , that is, their probability of failing in a small interval of time $(t, t+h)$ is equal to the failure rate $z(t)$ multiplied by the small interval h as h tends to zero" [Borgan \(2005\)](#). If $T_1 < T_2 < T_3 < \dots < T_n$ are the ordered time observations where at least one failure was recorded, and n_i, d_i are the numbers at risk and the numbers that failed respectively at T_i then, in general, the Kaplan-Meier estimator is computed as:

$$\hat{R}(t) = \prod_{T_i \leq t} \frac{n_i - d_i}{n_i} \quad (3.6)$$

The function $\hat{R}(t)$ thus estimated by the Kaplan-Meier (KM) technique is known as the empirical survival function which practically is equivalent to the reliability or survival function discussed earlier in the parametric models. The KM method can be used to estimate the MTTF of components such as bearings (Figure 3.2).

The Nelson-Aalen Estimator

The Nelson-Aalen technique is used as an estimator for the cumulative hazard function, $Z_{NA}^{\hat{}}$ and it is defined as

$$Z_{NA}^{\hat{}} = \sum_{T_i \leq t} \frac{d_i}{n_i} \quad (3.7)$$

In [Meeker and Escobar \(2014\)](#), it is shown that the Nelson-Aalen estimator (or simply, the Nelson estimator), $Z_{NA}^{\hat{}}$ is asymptotically equivalent to the Kaplan-Meier estimator, $\hat{R}(t)$. The Nelson-Aalen estimator is not included in the 2015 version of the Minitab statistical software (Minitab version 17.2.1) used to demonstrate the discussed concepts in the next section but it does include the so-called "hazard-plot," which in fact is not a correct approximation to the cumulative hazard function estimated by Nelson-Aalen.

The ideas discussed in the preceding paragraphs are further illustrated through a case study using publicly available standard data from ball bearing observations. The main focus of this report is not on the statistical inferences instead the objective is to find a valid ground upon which to base the maintenance decision process. Discussions on hypothesis testing, confidence intervals, censoring, standard deviation and variance are well covered in statistical textbooks hitherto referenced in this report.

3.2.3 Case Study: Analysing the Ball Bearings Failure Data

The purpose of this section is to illustrate the topics discussed in the two immediately preceding sections with the use of a case study. The analysis is carried out using the Minitab statistical software. The numbers used are from a standard data-set generated from ball bearings in the case where 23 units were monitored for how many million revolutions were made before a fatigue failure was recorded. The data is tabulated and presented on Table 3.2.

One common task is to plot the hazard rate and test the model. The test shows whether or not there was an increasing failure rate (IFR) or a decreasing failure rate (DFR). By observation, if the curve of the hazard rate function is convex it means the failure rate is increasing and when it is concave it means the failure rate is decreasing. In this case study, however, the aim is to show that the assumed model in a parametric analysis will influence the the results obtained. Since these results feed into the maintenance decision loop it is always a careful consideration to es-

Table 3.2: Millions of Revolution to Fatigue Failure for 23 Units of Ball Bearings

Unit #	Revolutions	Unit #	Revolutions
1	17.88	13	68.64
2	28.92	14	68.64
3	33.00	15	68.88
4	41.52	16	84.12
5	42.12	17	93.12
6	45.60	18	98.64
7	48.40	19	105.12
8	51.84	20	105.84
9	51.96	21	127.92
10	54.12	22	128.04
11	55.56	23	173.40
12	67.80		

timate accuracy. Figure 3.3 shows the four scenarios where the data was treated based on the Weibull, normal, lognormal and exponential models assumptions. It provides a table of MTTF as well as percentiles. The Anderson-Darling's measure of goodness-of-fit shows that the lognormal model has the smallest value which means it is the best fit for the data. The implication is that the MTTF of 72.7 months estimated by the lognormal model should be trusted more than the MTTF of 72.2 months estimated by the exponential model and so on.

The analysis was conducted based on the 95% confidence interval (CI) but Minitab has the option to change this if the analyst has another preferred choice. In other instances, it is the case that the analysed data was derived from an experiment. In such cases it might be required to make total time on test (TTT) plots or the accelerated life tests analysis. The homogeneous and non homogeneous Poisson processes are also important stochastic techniques used for data analysis. Within the big data paradigm, maintenance practice for the future stands to benefit from rigorous data analysis for a more efficient maintenance function.

The challenge to industry is how to structure and organise the data in a form that it can be analysed to provide useful inputs for maintenance decision support. In the case of vibration data, Industry 4.0 provides another level of challenge, the data has to be processed and presented in formats that are compatible with the Industrial Internet of Things (IIoT) systems. Some aspects of that challenge was studied in this report and a proposal was made for tackling the challenge in chapters 4 and 6.

Minitab Output for the Ball Bearings Failure Distribution Plot:

Goodness-of-Fit

Distribution	Anderson-Darling (adj)
Weibull	0,895
Lognormal	0,741
Exponential	3,381
Normal	1,181

Note that decimal points are shown with commas.

Table of Percentiles

Distribution	Percent	Percentile	Standard Error	95% Normal CI Lower	95% Normal CI Upper
Weibull	1	9,17577	3,57505	4,27561	19,6919
Lognormal	1	18,8546	3,94833	12,5074	28,4228
Exponential	1	0,725844	0,151349	0,482342	1,09227
Normal	1	-13,0792	14,7184	-41,9267	15,7684
Weibull	5	19,9265	5,46188	11,6444	34,0994
Lognormal	5	26,9043	4,48907	19,3997	37,3119
Exponential	5	3,70445	0,772430	2,46170	5,57457
Normal	5	11,9091	11,7274	-11,0761	34,8944
Weibull	10	28,0651	6,31510	18,0564	43,6215
Lognormal	10	32,5187	4,77371	24,3881	43,3599
Exponential	10	7,60923	1,58663	5,05653	11,4506
Normal	10	25,2303	10,3178	5,00776	45,4529
Weibull	50	68,7730	8,03885	54,6917	86,4798
Lognormal	50	63,4583	6,90294	51,2738	78,5383
Exponential	50	50,0597	10,4382	33,2660	75,3314
Normal	50	72,2209	7,64558	57,2358	87,2059

Table of MTF

Distribution	Mean	Standard Error	95% Normal CI Lower	95% Normal CI Upper
Weibull	72,5154	7,5939	59,0596	89,037
Lognormal	72,7087	8,4302	57,9288	91,260
Exponential	72,2209	15,0591	47,9927	108,680
Normal	72,2209	7,6456	57,2358	87,206

Ball Bearings Failure Data Plots:

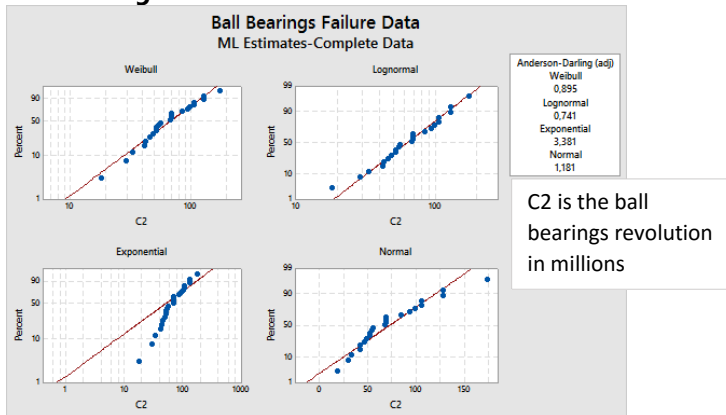

Figure 3.3: Minitab Output for the Ball Bearings Failure Distribution ID Plot (The Figure shows that the lifetime distribution model assumed for an analysis will influence the results. The MTF estimates for example gave slightly different values across the distribution models.)

Chapter 4

Rotating Machines Prognostics: The Science & Art of Vibration Technique

Vibration is characterised with frequency (measured in Hertz, CPM or RPM) and amplitude (measured either as peak, peak-to-peak or RMS values). The vibration energy can be described in terms of either the displacement (measured in micrometres), velocity (measured in millimetres per second) or acceleration (measured in metres per square second) caused by its transmission. A vibration signal can be related to another vibration or reference signal in terms of phase. There are several international standards dedicated to best practises in vibration analysis. They are mostly focused on the area of using vibration analysis for the purpose of operational monitoring and acceptance testing of rotating equipment or reciprocating machines. They often generally cover diagnosis but there is so far neither an existing standard nor is there available any proven technique to use vibration analysis to implement system prognosis. This is important because gaining an early awareness about an impending failure provides the opportunity to mitigate surprises and plan maintenance based on a schedule to optimise production time and reduce downtime. This chapter proposes a technique that provides a basis for using vibration analysis to carry out system prognosis within the framework of a predictive maintenance policy. The result can be treated with the stochastic processes and lifetime models introduced earlier in chapter 3 but as shown later in chapter 6 it is equally compatible with Industry 4.0 proposals and reference architecture. The discussion begins with an introduction to two important standards to aid a better understanding of the topic.

4.1 Mechanical Vibration and the ISO 10816 and ISO 7919

4.1.1 ISO 10816 (Parts 1 and 3)

The ISO 10816 is one of the key international standards that set out the procedures and conditions for measurement and evaluation of vibration data. The ISO 10816 specifically focuses on measurements made on non-rotating/nonreciprocating parts of the machine. It stipulates two evaluation criteria. These are the magnitude of vibration and the change of vibration. The vibration signal captured from a machine is specified to be broadband in the sense that the frequency spectrum of the equipment under consideration is reasonably covered. The appropriate frequency range for any given type of machine will depend on its configuration and the experience with its vibratory behaviour.

The overarching objective of any vibration analysis system is to determine the vibration severity of a machine and the trend of the vibration over time, increasing or decreasing. In order to meet this objective, measurements are made at carefully selected measurement points and often in two or three different directions which are mutually perpendicular (ref. Figure 4.1). This results in a set of vibration data representing vibration magnitude. By definition, vibration severity is the *maximum broadband magnitude value measured under agreed machine support and operating conditions* [ISO10816-3 \(2009\)](#). In many machines a single vibration severity value is enough to characterise the vibration level however in other cases it will be insufficient and a more accurate representation will depend on a number of severity values from several locations. The vibration severity at each bearing housing or pedestal is compared with the four predetermined evaluation zones (Zones A, B, C and D) stipulated by the ISO 10816-1 and ISO 10816-3 standards to give the indication of normalcy, alarm or trip [ISO10816-1 \(1995\)](#). More information and charts are provided in the appendices to this report. The measuring positions are marked and subsequent measurements are taken from the same positions with the same transducer orientations and similar operating conditions, otherwise it may produce an erroneous result when trended over time. When these conditions are met, significant changes from the established normal vibration readings must be investigated further to avoid reaching a position which could be dangerous to the continued operation of the machine. It is however important to note that in some cases some deviations cannot be detected unless the frequency components

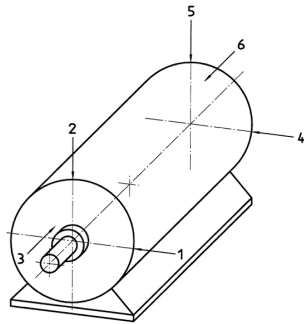

Item 1: Measuring points for small electrical machines

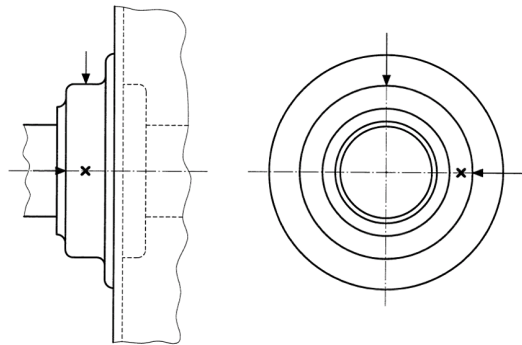

Item 2: Measuring points for housing-type bearings

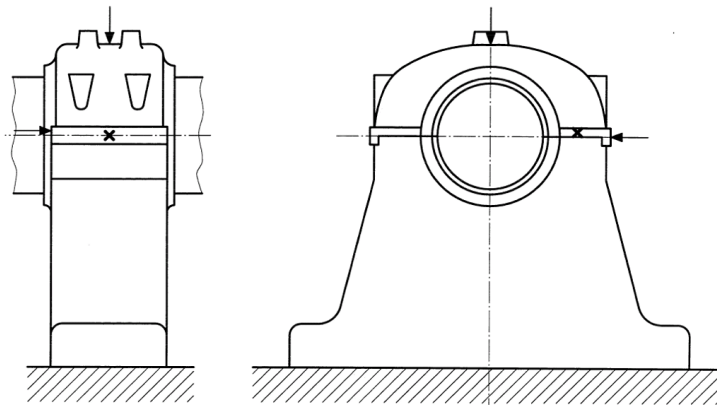

Item 3: Measuring points for pedestal bearings

Figure 4.1: Points for Measuring Vibration

ISO10816-1 (1995)

of the vibration signal is analysed. A case study at the end of this chapter shows the benefits of such analysis.

4.1.2 ISO 7919 (Parts 1 to 5)

The ISO 7919 standards cover the so-called "shaft vibration" and are formerly entitled: "*Mechanical Vibration of non-reciprocating machines - Measurements on rotating shafts and evaluation criteria.*" Thus, the ISO 7919 standards compliment the ISO 10816 standards though with the key difference that the ISO 7919 address measurement of vibration on rotating parts whereas the ISO 10816 address measurement of vibration on non-rotating/nonreciprocating parts. Machines with flexible rotor arrangements are typical of scenarios where vibration measurements are preferably made on the rotating parts in order to obtain a better result. Shaft vibration measurements are also the preferred choice when the casings are relatively more stiff or heavier compared to the machine's rotor mass. Measuring shaft vibration directly on the rotating parts helps to determine: *changes in the behaviour of vibration, disproportionate kinetic loading, and radial clearance monitoring* [ISO7919-1 \(1996\)](#). Issues of kinetic loading and radial clearances are not within the scope of this report; the technicalities of the ISO 7919 is not investigated further.

4.2 Frequency Peaks as Discrete Values

There are several rigorous mathematical theories which have been developed and applied in the field of vibration analysis. Such theories, some of which are grounded in classical physics or calculus, have been proven in other credible sources and would not be repeated here. However, vibration analysis is not all about mathematics and the sciences, it generally also engages the human creative and imaginative energy. Such creative, imaginative skills are elements of the arts which the vibration analysts must include in their analytical tool boxes. I earlier mentioned that frequency is measured either in hertz (which by definition means cycles per second) or in CPM/RPM. The third unit of frequency is "Orders," an important measure that aids a more imaginative and more useful interpretation of the relationship between the rotating members' turning speeds/frequencies, forcing frequencies/excitation energies and their frequency responses in the spectrum. Figure 4.2 shows a rotating machine and the frequency spectrum

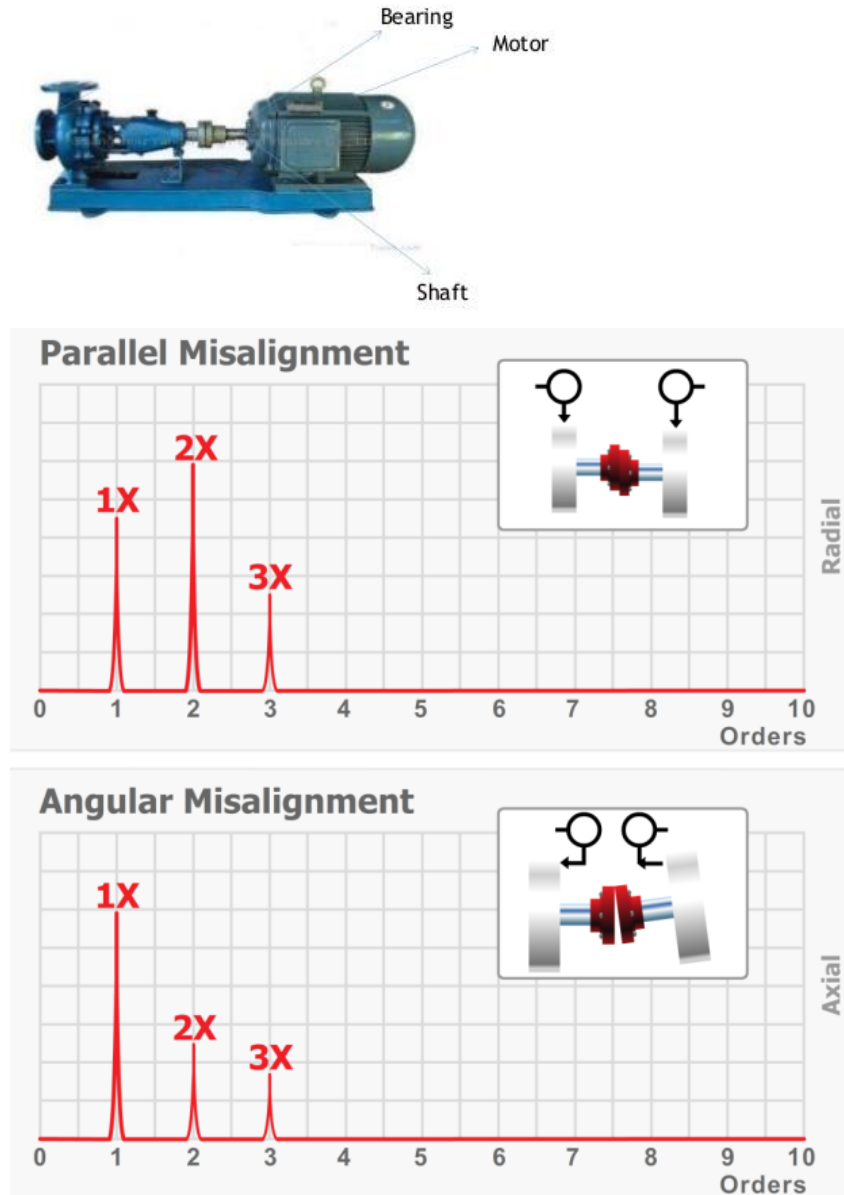

Figure 4.2: Spectral Patterns for Parallel/Angular Misalignment of a Shaft Rotating at the Shaft Rate Frequency "1X".

patterns (peaks shown in "orders"). A trained vibration analyst can distinguish between a parallel or angular misalignment of the shaft by observing the patterns.

The fundamental question is what is order? Imagine sitting a set of twins (a girl and a boy) on a four-arm merry-go-round rotating on a shaft at a certain frequency. Imagine that the initial orientation of the four arms align with the cardinal points (north, south, east, and west). Imagine that the boy and the girl sit on the north and south arms facing each other. Each of the twins will pass in front of an observer standing at a fixed position nearby once each time the merry-go-round makes one full revolution irrespective of its frequency. In terms of order, the girl or the boy considered separately passes at one times the shaft rate; and considered together they pass at two times the shaft rate, conventionally abbreviated "1X" and "2X" respectively. It does not matter if the actual turning speed of the merry-go-round was 50 Hz, 1000 Hz or changing. Knowing the frequency of occurrence of an event relative to the turning speed is very useful in vibration analysis. Units of orders provide a clue to the source of peaks in the frequency spectrum. From the merry-go-round example cited above, a peak present at 2 orders (that is, 2X) can be easily related to the "twins" pass frequency and thereby helping to eliminate other sources as possible causes of the fault. The example can be expanded to include an electric motor, a pump or compressor and so on. In an induction motor where the rotor was wound with 38 bars, a peak present at "38X" could relate to a trouble with one of the bars; it does not matter if it is used with a variable-frequency drive (VFD) or fixed-speed systems, the absolute frequency in hertz or CPM is not of any practical interest. Therefore, it is valuable to relate every peak in the spectrum to the motor shaft rate ("1X") and also to relate one peak to the other. Another benefit of measuring frequency unit in "orders" is that it makes it easier to compute forcing frequencies. In general, forcing frequencies (also known as defect or fault frequencies) is computed by multiplying the number of components by the shaft rate. Refer to Figure 4.3, the blade pass rate is equal to the number of blades times the shaft rate of the shaft the blades are mounted on (that is, $7 \times 3,300 = 23,100$ RPM or $7 \times 55 = 385$ CPS, as in the current example). The lengths of the respective peaks are single discrete values which represent the magnitude or severity of vibration. If, for example, something goes wrong with the blades but not with the shaft and coil such that the vibration energy from the blades should increase, the magnitude of the frequency peak at 385 Hz increases in response. If the vibration energy increases even further, peak equally increases

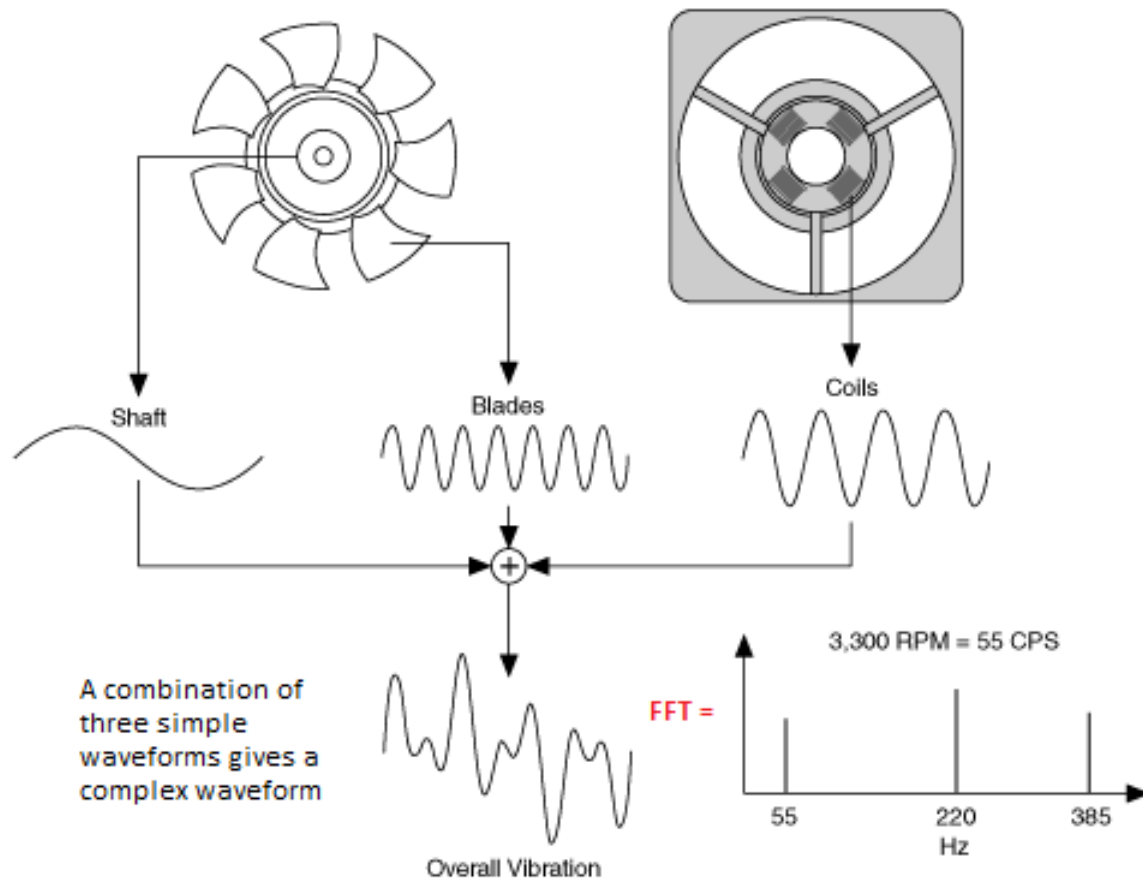

Figure 4.3: Forcing Frequencies and Frequency Peaks in Spectrum (The Figure shows three simple sinusoidal waveforms from the shaft, blades and coils combining into a complex overall vibration signal. When the FFT is applied to the complex vibration signal, the frequencies are separated into their respective peaks, note: 55 Hz for the shaft (corresponding to "1X"), 220 Hz for the Coils (corresponding to "4X") and 385 Hz for the blades (corresponding to "7X."))

in response. The study conducted in thesis shows that there is a possibility to use this frequency response feature for prognosis by applying some stochastic techniques. The remaining part of the current chapter is dedicated to discussing how to follow this pattern over time and predict when in the future the peak from the blades becomes dangerous to the continued operation of the machine.

4.3 The Autoregressive Moving Average (ARMA) Models

ARMA is a popular time series analysis tool for forecasting because it provides a reasonably more accurate result than the cumulative and naive models and is simple to implement. The major drawback often encountered in the use of the ARMA model is its requirement for a large amount of historic data in order to be able to produce an accurate result. [Abrahart and See \(2000\)](#) and [Khashei et al. \(2009\)](#) among others proffer a combination of the "moving averages" with the artificial neural networks (ANN) and fuzzy logic as a possible solution. This report does not focus on that integration instead it advocates the correct use of prevalent "big data" to overcome the hurdle of historic data. It can be decided how many periods should be included in the model. For example, a 2 period moving average (MA) or 14 period MA could be the preferred choice. The main driver for how many periods to include is the length of time for which the history is relevant. Adapting this model for the purpose of prognosis on a maintainable system, any record of history held prior to an overhaul is not relevant in the next round of prognosis after the overhaul though the data may be useful for benchmarking or comparison in the future. The general form of an M-Period ARMA model is shown in equation 4.1.

$$x_{t,\hat{t}+1} = \frac{\sum_{i=t+1-M}^t x_i}{M} \quad (4.1)$$

where

$x_{t,\hat{t}+1}$ = is the forecast for period $t+1$ (that is the future) from period t (today)

x_i = the value of the measurement made at the earliest period of the M-period considered

M = number of relevant periods

There is no hard and fast way for choosing M . A large M is generally preferred when the goal is to predict way into the future. Period as used here is not defined. It can be a month, a quarter or a year. It is important to note that it is more practicable to predict a range of values rather than just predicting a single value. That is, it is more realistic to predict that an equipment will fail 30 to 34 weeks from now rather than predicting that the equipment will fail on the evening of the 32nd week from today, and so on. The challenge is overcome by the introduction of "confidence intervals" and the consideration of random fluctuations but that aspect was left out of this report for a future investigation.

4.4 Case Study: Implementing System Prognosis with the Thruster Gearbox Bearing Spectra

The ARMA model introduced in the previous section and the lifetime models discussed in chapter 3 are validated in this section through a case study of measurements made on a roller element bearing at one of Karsten Moholt customer's machines. The velocity spectrum for a component of the thruster system, that is one of the gearbox bearings was analysed. The waterfall plot of the spectra from the bearing is shown in Figure 4.4. Each spectrum represents the frequency response in a specific survey period shown against the date of the survey. The passing and successive survey period spectra are superimposed for easier visualisation. The survey periods are assumed to be at six months interval. That is a logical deduction but it was not exactly the case. It is important to assume an equal interval to proceed with the regression analysis. The results of the regression analysis is shown on Figure 4.5. The numbers used for the regression were obtained by taking the average of 5 peaks on a survey period: the maximum peak for the period, two next lower peaks on the left and two next lower peaks on the right. The frequency range of interest was from 250 Hz to 300 Hz (this frequency range is associated with the bearing of interest). The vibration severity or peaks are measured in millimetres per second.

From the regression analysis, the model for predicting the next period's expected vibration severity was derived as $1.096117 + 0.795704 * Y_t$ (where Y_t is the vibration severity of the most recent survey period.) The model predicted the vibration severity for period 9 as 4.96 millimetres per second. Having a systematic way to carry out such predictions has many benefits. In the

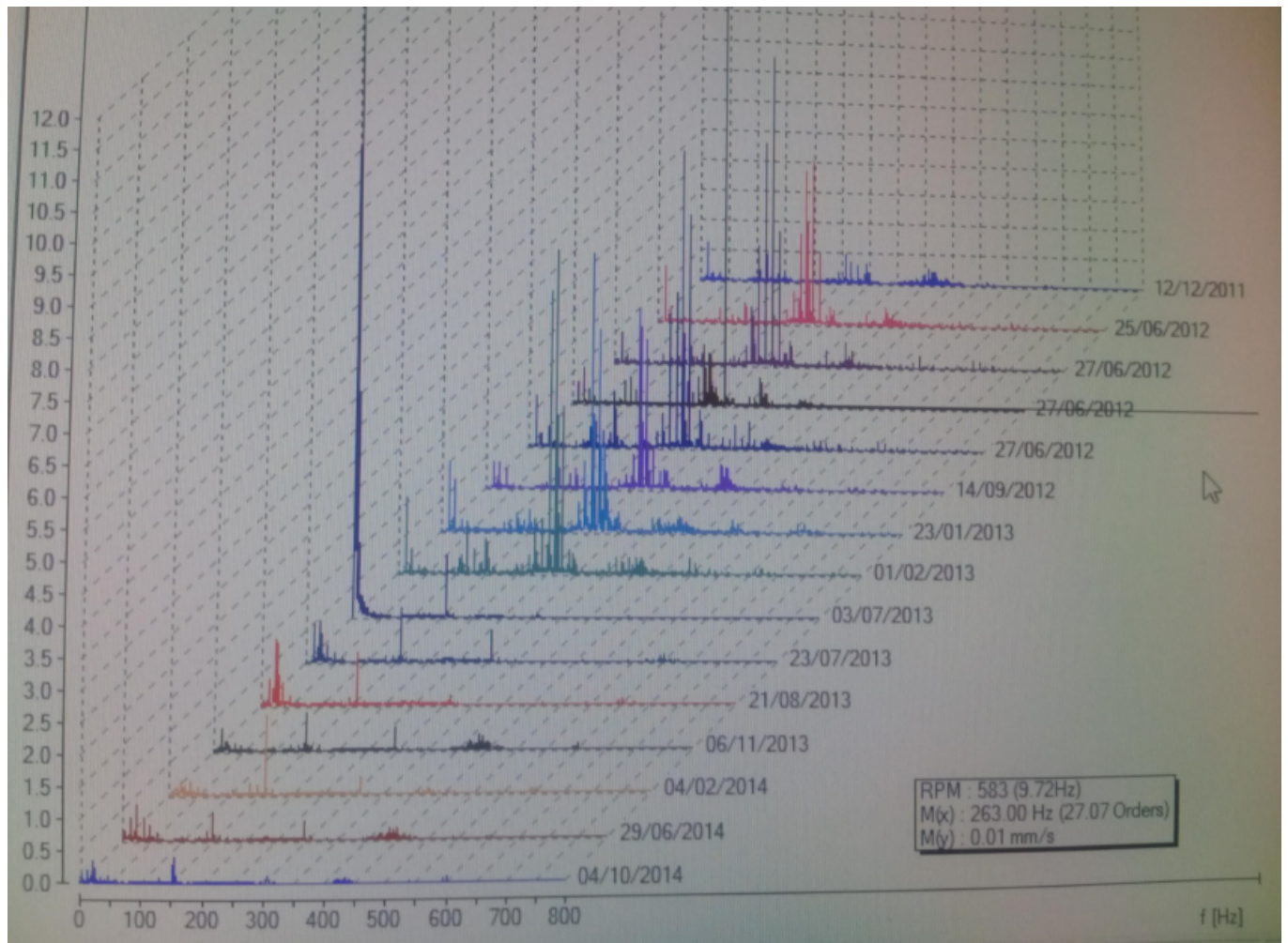

Figure 4.4: Waterfall Plot of Spectra from Different Survey Periods (The Figure is a screen shot from the Omnitrend software analytical tool used for this thesis courtesy of Karsten Moholt AS. It shows the spectra from survey periods indicated by date. 5 peaks occurring between 250 Hz and 300 Hz were averaged to smoothen the data's variability)

current case study, surveys were repeated at six months interval. At the end of each survey, it is possible to predict what we expect the vibration severity to be six months from the most recent survey campaign. Should the predicted vibration severity be significantly higher than the predetermined acceptable levels, the asset managers have the benefit of initiating the plan to carry out maintenance long before the possible failure of the component. While working in partnership with the industry for this research some experts within the field of vibration analysis were interviewed, it was observed that maintenance engineering service providers may have reason to permit the continued use of an equipment even when a trend that could lead to failure has been observed. The main reason for not carrying out maintenance as soon as the first sign of possible failure is known was found to be predicated upon considerations for production interruption. In such situations where it was necessary to escalate the maintenance requirements, the engineering company was observed to have offered the equipment utilisation extension based on "expert judgement and best guesses or honest estimates." The systematic approach proposed in this report offers a more scientific and objective technique for reaching such decisions. Another question that is necessary to address is what the appropriate survey interval should be. This is a difficult question as it will generally involve commercial and contractual considerations. The accessibility of the equipment and the cost to personnel or in extreme cases interruption to production flow are among important factors to consider before the survey interval is selected. Due to random events, it might sometimes be necessary to embark on vibration data collection at a time that is off the agreed interval. In such cases, the asset managers have to document and implement the schedules without distorting the planned survey periods. It might sound like painstaking bookkeeping but that is where the CMMS comes into play.

Model Limitations

The model has the following limitations:

- Only a few data points (7 observations) were used to train the model.
- The recorded readings were made at different machine revolutions. It was only after July 3rd 2013 that measurements were made consistently at 680 RPM. Between December 12, 2011 and February 1st 2013 the RPM ranged from 583 to 710. This is contrary to the rec-

Survey Period	Y	X	Survey Period	Y	X
1	0.65		2	2.29	0.65
2	2.29	0.65	3	2.55	2.29
3	2.55	2.29	4	2.34	2.55
4	2.34	2.55	5	2.42	2.34
5	2.42	2.34	6	2.84	2.42
6	2.84	2.42	7	3.86	2.84
7	3.86	2.84	8	4.86	3.86
8	4.86	3.86	Model Prediction for: 9	4.96	

Prediction model based on regression analysis = Intercept + Coefficient of X * the last Y observation
 = 1.096117 + 0.795704 * 4.86 = 4.96 mm/s vibration severity

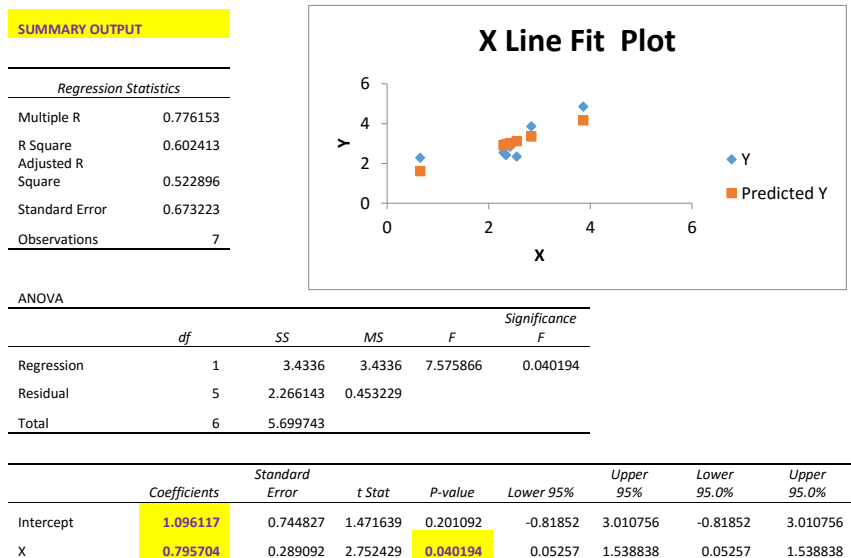

RESIDUAL OUTPUT

Observation	Predicted Y	Residuals
1	1.613324	0.676676
2	2.918279	-0.36828
3	3.125162	-0.78516
4	2.958064	-0.53806
5	3.02172	-0.18172
6	3.355916	0.504084
7	4.167534	0.692466

PROBABILITY OUTPUT

Percentile	Y
7.142857	2.29
21.42857	2.34
35.71429	2.42
50	2.55
64.28571	2.84
78.57143	3.86
92.85714	4.86

Figure 4.5: First Order Linear Regression of Vibration Severity/Peaks (The Figure shows an insert of the final tables used to implement first order linear regression on the vibration severity data. The model for predicting next period vibration severity is derived and shown. The line fit plot gives an indication of how the predicted and observed values match each other. The model is valid as the p-value is less than 0.05.)

ommendations made in [ISO7919-1 \(1996\)](#) and [ISO10816-3 \(2009\)](#) and certainly has an influence on the derived model.

- Frequency peaks were measured without linking them with their corresponding phase angles. Treating frequency as a vector quantity rather than as a scalar produces better results as shown in the standards referenced in the above bullet point.
- The interval between the survey periods were not equal. In some cases it was approximately six months but it was not generally the case.
- The regression analysis has been carried out using the data analysis function in Microsoft Excel. It was sufficient to demonstrate the result but a commercial application would require a more advanced software perhaps application tailored computing.

In order to overcome the aforementioned limitations, the pursuit of predictive maintenance and prognostic techniques need be a rigorously implemented policy. Lots of data are now being generated within industrial applications and with the continued improvements in sensor technology, data mining will witness an upward trend. It is necessary to look into the generated data, structure and analyse it to help in maintenance decision support as well as other value added services. Data scientists will play an increasingly important role in the future of maintenance practice. Analysing a sufficient amount of data from the same or similar machines with some statistical techniques such as the lifetime models introduced in chapter 3 will improve asset reliability and availability. The application of the Nelson-Aalen estimator and the Kaplan-Meier estimator techniques introduced also in chapter 3 to the relevant data sets can aid better understanding of components' failure trajectories and a more accurate estimation of the machine's MTTF for example. The big data is important but the systematic analysis of the big data provides the value adding perspective that would help organisations to realise their overarching business functions to maximise stakeholders' value.

Chapter 5

A Business Case Study for PdM: The Karsten Moholt Experience

This chapter answers one of the report's sub-objectives. It seeks to justify why predictive maintenance (PdM) regime provides better incentives for businesses compared to plants running in predominantly corrective and/or preventive maintenance modes. The sub-objective is reached by means of cost assumptions on a thruster assembly based on Karsten Moholt's experience. The numbers and costs used were derived from actual engineering specifications and current market index.

Whereas this report is primarily focused on vibration analysis (VA) and the vibration based condition monitoring (VBCM), the current chapter has a broader coverage of the predictive maintenance philosophy. In practice, a PdM regime embraces more than one form of condition monitoring (CM). For example, the typical defects that can be detected by means of a VA are gear wear or broken tooth and bearing defects. Seal wear or leakages are better detected through oil analysis techniques or by means of other sensor technologies. Table 5.1 provides a more comprehensive picture of some machine components and the suitable CM techniques for detecting faults. A physical plant is often comprised of different components from tens of components to thousands of components depending on the complexity and scale of operation. Maintenance in such circumstances entail mixing and matching of different maintenance philosophies. At the scale of hundreds or thousands of components, the computerised maintenance management systems (CMMS) are usually almost inevitable. The CMMS is important to organise tasks,

Table 5.1: Machines and the Suitable CM Technologies for Defects Identification (adapted from the Mobius Institutes' Category I Vibration Training Course Book)

	Technology						
	Vib	Lube	Wear	MCA	IR	US	Vis
Generator	YES	YES	YES	NO	YES	YES	YES
Turbine	YES	YES	YES	NO	YES	YES	YES
Pump	YES	YES	YES	YES	YES	YES	YES
Elec. motor	YES	YES	YES	YES	YES	YES	YES
Diesel eng.	YES	YES	YES	YES	YES	YES	YES
Fan	YES	YES	YES	YES	YES	YES	YES
Gearbox	YES	YES	YES	NO	YES	YES	YES
Cranes	YES	YES	YES	YES	YES	YES	YES
Elec. Circ.	NO	NO	NO	YES	YES	YES	YES
Transformer	NO	YES	NO	YES	YES	YES	YES

track and document maintenance in structured manner to minimise maintenance costs while optimising up-time for production in accordance with established objective functions.

Using The Predictive Maintenance Regime to Minimise Maintenance Costs – A Case Study of Thruster Assemblies

The following assumptions were made based on the OEM's (manufacturer's) recommendations and the operator's field experience:

- Background: one of Karsten Moholt's customers, The NTNU Good Diggers (not their real name) is a drilling company based on the Norwegian continental shelf portion of the North Sea. The company has adopted a PdM policy for the thruster assemblies on their drillships and semi-submersibles. The company deploys 8 thruster assemblies per rig across a total of 22 rigs.
- The MTBR for a thruster is 5 years
- The cost to overhaul one thruster assembly is 1,060,000 USD (a thruster assembly is as good as new after an overhaul)
- An overhaul is due every 5 years as per calendar based preventive maintenance (PM).

- Estimated PM per year (covering the costs for routine inspections, filter change, fluid change/top up among other PM tasks = 25,000 USD
- The dry dock cost per rig (that is 8 thrusters) is 400,000 USD per day
- Docking mean downtime is estimated to be 20 days

For the PM policy:

- The cost to overhaul one thruster = 1,060,000 USD every 5 years (or 212,000 USD per year)
PM tasks = 125,000 USD every 5 years (25,000 USD per year)
- For one rig (total of 8 thrusters), dry dock cost per day for 20 days MDT = 400,000 X 20 = 8,000,000 USD per rig every 5 years or 1,000,000 USD per thruster every 5 years (that is 1,600,000 USD per rig per year or 200,000 per thruster per year)
- In 5 years, the **estimated total maintenance cost** per thruster = Cost of PM + cost of overhaul + cost of dry dock for the period = 125,000 + 1,060,000 + 1,000,000 = **2,185,000 USD** per thruster every 5 years (or **437,000 USD** per thruster per year)
- This gives 2,185,000 X 8 = **17,480,000 USD** per rig every 5 years (or 3,496,000 USD per rig per year)
- and 17,480,000 X 22 = **384,560,000 USD** in 5 years (or 76,912,000 USD per year) for the entire platform operated by the NTNU Good Diggers but only with respect to the maintenance of thrusters.

For the PdM policy:

With the implementation of a predictive maintenance policy, it is practicable to extend the MTBR by a factor of 1.2 from 5 years to 1.2 X 5 = 6 years. That gives the following computations:

- The one year total average maintenance cost of each thruster = Cost PM + cost of overhaul + cost of dry dock (yearly average each) = 25,000 + (1,060,000/6) + (1,000,000/6) = 25,000 + 176,667 + 166,667 = **368,334 USD** per thruster per year.

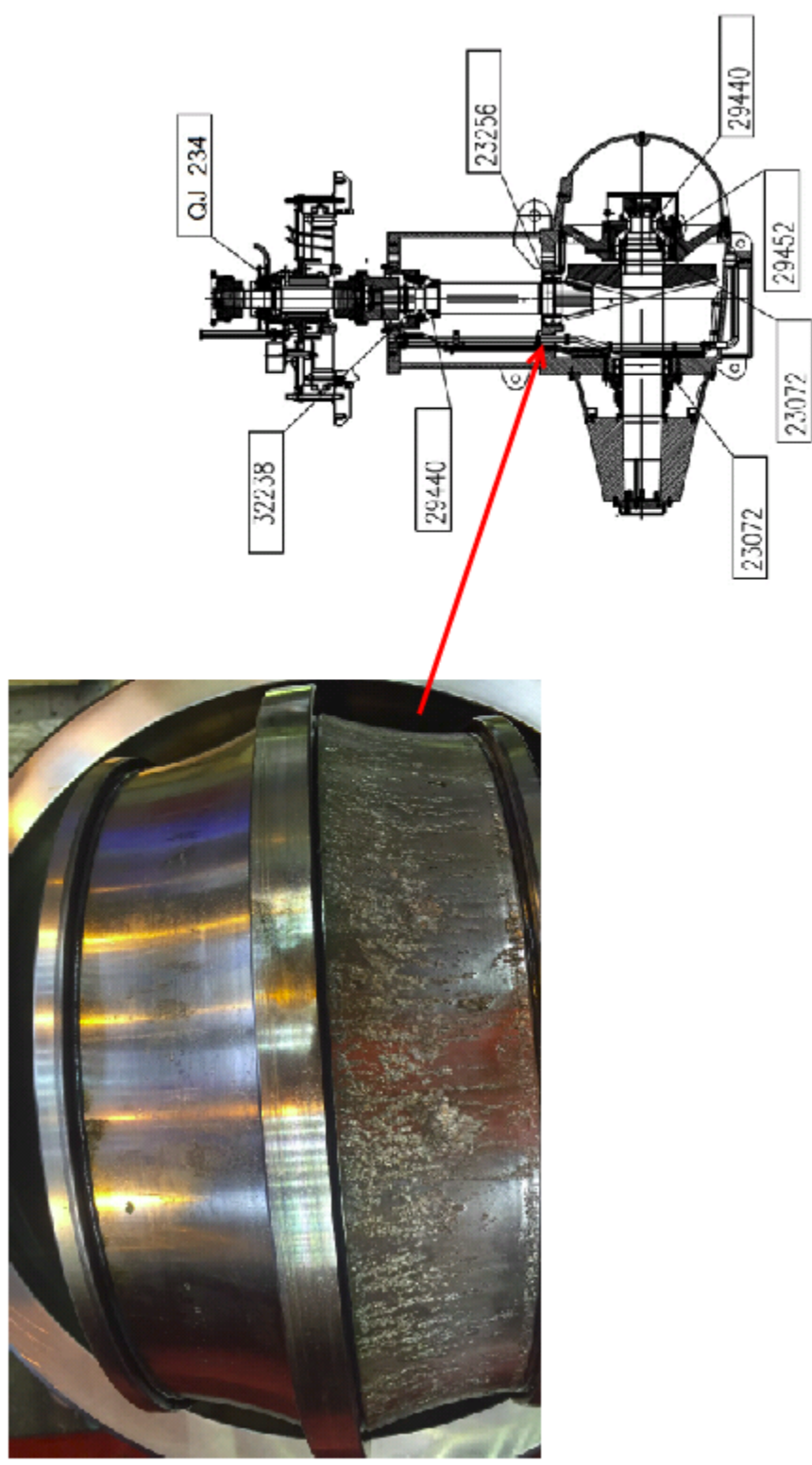

Figure 5.1: A Thruster's Pinion Bearing and Rollers show extensive damage: a confirmation of an earlier vibration analysis carried out by Karsten Moholt predicting the damage

Alternatively, rather than extending by a factor of 1.2 as earlier proposed, it was argued that a sufficient evidence exists to support extending the MTBR by a factor of 1.5, that is from 5 years to $1.5 \times 5 = 7.5$ years. In that case, the following computations will apply:

- The one year total average maintenance cost of each thruster = Cost PM + cost of overhaul + cost of dry dock (yearly average each) = $25,000 + (1,060,000/7.5) + (1,000,000/7.5) = 25,000 + 141,333 + 133,333 = \underline{\mathbf{299,666\ USD}}$ per thruster per year.

The NTNU Good Digger's maintenance budget for a total asset of 22 rigs (focusing only on the thrusters – 8 per rig) the three cost scenarios outlined above compares as follows:

1. The calendar driven PM policy (5 years interval) = $437,000 \times 8 \times 22 = 76,912,000$ USD total per year
2. PdM 6 years policy = $368,334 \times 8 \times 22 = 64,826,784$ USD total per year
3. PdM 7.5 years policy = $299,666 \times 8 \times 22 = 52,741,216$ USD total per year
4. Compared to the ordinary calendar PM, the PdM programme with a 6 years renewal policy offers cost savings of 12,085,216 USD per year and the alternative 7.5 years renewal policy offers cost savings of 24,170,784 USD per year to the operators from the thruster maintenance budget alone.

During the actual investigation by Karsten Moholt, it was found that only 9 thrusters showed signs of deviation after 5 years and required maintenance. However, because PdM is still an ongoing investigation within the oil and gas sector, the calendar PM was followed and all the thrusters were overhauled as per the operator's maintenance programme recognised by the Norwegian regulatory authorities. Figure 5.1 shows one of the thrusters that was found to have a damaged bearing. Modifying the assumptions made in this case study will produce slightly different cost savings but under any reasonable set of assumptions, the savings will always be substantial. In contrast, the total cost of acquiring a world class CM technology is likely to be a fraction of a million USD. The conclusion is that predictive maintenance is an economically beneficial policy for every production asset. It is recommended that every asset manager should investigate the use of PdM to increase asset availability and boost productivity.

Chapter 6

Smart Maintenance: Interfacing Vibration

Data with the IIoT

There is a paradigm shift away from traditional manufacturing and standalone systems towards more integrated and smart factory concepts known as Industry 4.0 or advanced manufacturing. However, a major concern expressed within the industry is that the current approach presented within Industry 4.0 (that is, the Industrial Internet of Things (IIoT) [Evans and Annunziata \(2012\)](#)) for implementing predictive maintenance places too much emphasis on low level data monitoring to a degree that compromises the level of competence already achieved within the industrial application of vibration based condition monitoring, and there is so far no proven method to overcome the challenge. Advanced signal processing techniques have been rigorously derived elsewhere and there is no doubt that the requirements for the digitisation of analogue signals have been met in other applications. The knowledge gap formulated as one of the sub-objectives and addressed in this report is the articulation of a method that provides the possibility to apply vibration analysis solutions to predictive maintenance services within the Industry 4.0 frameworks. The reference architectures proposed within Industry 4.0 advocate the use of single values for measured parameters. When applied to vibration based condition monitoring, it is important that the single value digital data interfaced with the Industry 4.0 smart maintenance loops does not lead to results which are considerably less accurate than today's level of competence in vibration analysis. The method proposed in this report is to use the "peaks" from spectral analysis as a representation of this single values. Future developments should ensure

that each peak is associated with its phase angle and the vector is resolved to obtain the resultant peak which is the actual value used for the analysis or results computation when fed into an algorithm. The result is a system that makes use of a single value data and also provides an accurate representation of the vibration energy produced by the rotating machinery. The Computerised Maintenance Management System (CMMS) forms an important foundational basis for the success of the proposed solution. For the purpose of clarification of terminologies, machine learning and machine-to-machine (M2M) communication are discussed. The enabling technologies that are driving the progress towards Industry 4.0 are defined and finally the concept of smart maintenance is presented in the context of these evolving paradigms.

6.1 Computerised Maintenance Management System (CMMS)

CMMS underscores the importance of computer tools in the execution of asset integrity systems and maintenance functions. It offers platforms for information storage and retrieval, data analysis and synthesis, as well as events coordination. There are many useful applications of the CMMS in the industry today but it is still believed to be greatly under utilised and limited well below its capability. In current industry applications, the CMMS is often used as equipment information storage tool and to hold data necessary for PM decisions and maintenance planning. [Gabbar et al. \(2003\)](#), for example, propose a more extended use, a system of an automated RCM which aims to integrate the RCM process with the CMMS. In an Industry 4.0 environment, the current sub-optimal use of the CMMS will be extended in two important ways. First, its design will make it possible to integrate actual equipment and maintenance key performance indicators (KPIs) directly into the decision loop for an effective coordination between maintenance and operational activities. Currently, interfaces are achieved with maintenance planning personnel in plants where such systems exist otherwise lack of proper coordination will gradually develop into an undesirable event. Direct link between actual performance measurements and the CMMS will boost confidence in the results obtained from an analysis and help to achieve a more realistic physical systems approximation. It will have a direct positive impact on safety and asset availability as well as lower operating and support costs. The second area is the incorporation of an artificial neural network (ANN) based on the cloud system and other KETs

Factory's Common Name	Mfg's Name	Model Number	Serial Number	Equip Description
FURNACE C14	THERMCO	TMXX	1657-14	Tube 14 in the Area

System will take Equipment Down				
Every Time 1000 Parts Are Produced	Rule is Enforced <input checked="" type="checkbox"/>	Currently 979 Parts Have Been Produced	Need to strip and replace tube every 1000 parts.	
Every Time 100 Lots Are Produced	Rule is Enforced <input checked="" type="checkbox"/>	Currently 62 Lots Have Been Produced	Or -- Need to strip and replace tube every 100 Lots.	
The Next Scheduled PM				
On This Date mm/dd/yyyy 01/31/2013	At This Time hh:mm 12:00	Rule is Enforced <input checked="" type="checkbox"/>	Full break down and rebuild of pumps and MFCs and gas lines and plumbing.	
The Next Scheduled CALIBRATION				
On This Date mm/dd/yyyy 03/15/2013	At This Time hh:mm 12:00	Rule is Enforced <input checked="" type="checkbox"/>	MFCs need recalibration.	
When 60 Days Pass Without PM	Rule is Enforced <input checked="" type="checkbox"/>	Check on the gas cabinets if no one has serviced this furnace in the last 60 days.		
310.612.7889@att.net, maint@semifab.c EMail to Notify When Equipment goes Down <input type="button" value="Save Changes"/> <input type="button" value="Go Back"/>				

Figure 6.1: A Screen Shot of a CAMP System Input Window

discussed below in the subsequent paragraphs.

Commercially available CMMS based on current applications include but are not limited to Systems Applications and Products (SAP), Computerised Aircraft Maintenance Programs (CAMP), emaint, Maintenance Connection, Aircraft Maintenance & Engineering System (AMOS) although the abbreviation is retained for historical reasons as it originally stood for Airline Maintenance & Operational Systems. I have worked with the CAMP system where I was responsible for managing heavy maintenance projects on the fleet of a commercial passenger airline. The CAMP system just like many other CMMS have different suits that allow subscribers to pay for what they need based on their budget and the unique requirements of their operation. In my former company we used the maintenance tracking or maintenance management suit for PM purposes, the Inventory Management System (IMS) for spare parts and related materials needs, and the engine health monitoring suit for Engine Condition Trend Monitoring (ECTM). More information on the CAMP system is available on the company's website: <http://www.campsystems.com>. A screen shot of a CAMP window is shown in Figure 6.1.

6.2 Machine Learning and M2M Communication

The current best practice within maintenance is to record faults or failures and the actions taken to rectify the snags on some dedicated log books. The CMMS introduced in the previous section can provide an additional capability of presenting these records in an electronic and searchable form. In addition, some sectors are well organised in their approach, for example, the aviation industry uses the Airlines Transport Association ATA chapters (see [ATA \(2001\)](#)) which helps aircraft engineers to group events in accordance with predefined systems. But it is basically an open reporting and documentation process that does not provide communication back to the equipment to close the loop and thereby leading to a missed opportunity for learning. It sounds valid to argue that every maintenance event provides a learning opportunity not only to better understand the machines in question but also for the organisation to continuously improve its maintenance concept in general. In the paper 1 of the part 2 of this report, it is proposed that some representative information from the event output should be fed back into the machine to facilitate this learning process. Possible outcomes of feeding back output signals to the process system include better knowledge about the machine and production process, automatic control of output quality based on some preset values, and a capability to predict possible future outcomes by comparing current state with historical characteristics of the process or system and system structure. In effect, the process is trained with its own sensor data and feedback information to identify patterns and provide a tool for system prognosis by following the trend of data over a period of time.

6.3 The Industry 4.0 and its Key Enabling Technologies (KETs)

Industry 4.0 is a strategic initiative that aims to radically combine manufacturing, automation and ICT into a vertical network within one entity, network two or more of such entities in a horizontal chain to create organisational end-to-end transparency (seamless value adding chain) for production. This section presents some of the key enabling technologies and the appurtenant evolving paradigms.

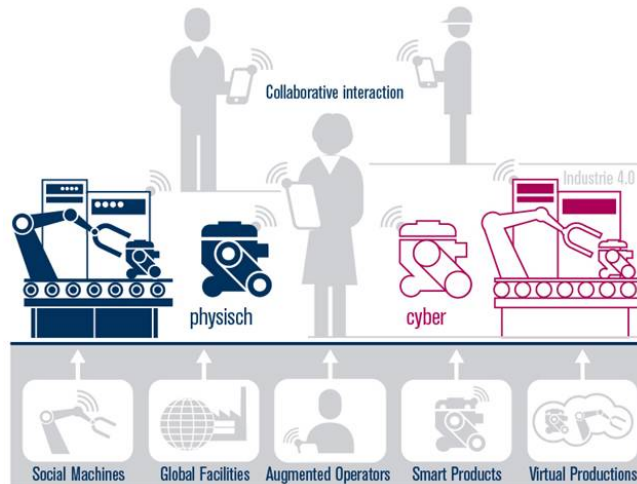

Figure 6.2: Collaborative Interactions within the Smart Factory (from [Kagermann et al. \(2013\)](#))

Internet of Things (IoT)

The traditional Internet today provides “connection” for over one billion people through platforms such as Facebook, Twitter and Google Hangout. However, the era of advanced and cheap sensors coupled with the successful derivation of the Internet Protocol IPv6 in 2012 means that there are now enough IP addresses to assign to every device (sensor, actuator or any object) configured in a way as to be networked directly with the Internet [Kagermann et al. \(2013\)](#). The Internet of Things refers to a pervasive, perhaps ubiquitous, network society in which a lot of objects are “connected” [Yan et al. \(2008\)](#). The concept of the smart factory to have a large network of small, decentralised intelligent embedded devices is driven by the IoT paradigm (see Figure 6.2).

The Cyber-Physical Systems (CPS)

The cyber-physical systems (CPS) are integrations of computation and physical processes [Lee et al. \(2008\)](#). Today, several systems are embedded with autonomous chips which are wirelessly networked with one another and also able to access the Internet thereby providing a tight and definite link between the cyberspace and the physical world. Such seamless interactions define the notion of cyber-physical systems (CPS). The benefits of CPS are obvious. Imagine that you have a smart device built into your mobile phone that continuously monitors/records your

blood pressure and is capable of not only being able to alert you in the event that measurements are not normal but is also able to schedule an appointment for you with a doctor or even call an ambulance in the event of an emergency; imagine also that this device is intelligent enough (maybe big data driven) to know that the sudden rise in your blood pressure was because you were being attacked by some bandits and also calls in the police; imagine as well that this device detects that you have not had enough sleep and resets your alarm clock two hours ahead and cancels your earliest appointments for the day. These are all realistic examples. Thus, systems or system of systems in a CPS scenario are able to communicate and control one another in a collaborative manner. The CPS has the novel advantage of being able to offer early warnings, mitigate surprises and is therefore well suited to predictive maintenance applications within the environments of the industrial Internet.

Big Data

Big data has been the *going concern* of many companies since the advent of the social media but the eventual implementation of Industry 4.0 will inadvertently lead to an actual data explosion resulting from machine generated big data. In that context, big data may be likened to cassava root or yucca which until it has been processed remains useless or even harmful no matter how succulent it appears to the owner. Big data analytics will become an important field with business opportunities in the future. Big data will be at the core of the predictive maintenance concept and the development of prognostic systems within the Industry 4.0 environment but it has to be processed and analysed. There is no doubt that advanced analytics can greatly enhance the decision-making quality as managers become armed with more data and are better informed. Big data is generated from small data obtained from sensors embedded into products such as subsea valves or automobile wheels to measure some desired physical quantities like temperature or flow-rate which are in turn analysed to support decision-making including maintenance decisions. A Boeing 737 NextGen airplane for example will generate about 240 terabytes of data during a one hour flight between two airports. These sensor data if properly analysed can provide good insight into the state of health of the airplane, its exposure to risk or its level of performance and thereby help the airline operator to prioritise maintenance decisions in a proactive manner ([Manyika et al. \(2011\)](#)).

Cloud Computing (CC)

Industry 4.0 will leverage on existing technologies such as cloud computing which actually is a cluster of services [Bai et al. \(2012\)](#). In relation to services, the discussion will be expanded further in the next paragraph dealing with the Internet of Services. The definition of cloud computing is rather cloudy perhaps because it is an evolving paradigm. However, the definition provided by the National Institute of Standards and Technology (NIST) is though not perfect but it is good enough for today's use. Cloud computing is a model for enabling ubiquitous, convenient, on-demand network access to a shared pool of configurable computing resources (for example, networks, servers, storage, applications, and services) that can be rapidly provisioned and released with minimal management effort or service provider interaction [Mell and Grance \(2011\)](#). It identified the three main components of this cloud model to have the following compositions:

- Five essential characteristics (On-demand self-service, Broad network access, Resource pooling, Rapid elasticity, Measured service);
- Three service models (Software as a Service (SaaS), Platform as a Service (PaaS), Infrastructure as a Service (IaaS)); and
- Four deployment models (Private cloud, Community cloud, Public cloud, and Hybrid cloud).

Internet of Services (IoS)

The Internet of data evolved into the Internet of information which has now largely developed into the Internet of Services (IoS). Web service interface and the service-oriented architecture (SOA) are the key drivers of the concept of loosely coupling services used either for technological or business purposes [Schroth and Janner \(2007\)](#). The application services available on these platforms will connect people, objects and systems and further possess specific features such as adaptability, support for collaborative use and diverse mobile end devices, process deployment along the lines of the App stores model, and should provide safety, security and reliability guarantee [Kagermann et al. \(2013\)](#). This can be illustrated using a human-system or system-system interaction. For example, if a group of tourists decide to travel from point A to point B, there are

several Apps they can leverage to make good choices. These Apps will combine services from several companies (airlines, hotels, taxis) and provide comparisons. It will show which airlines are cheaper or have shorter layovers or travel durations. You will know what type of aircraft will be used on your route; you can select your seat in the cabin and order a meal in advance. The Apps can also provide weather information and help the tourists decide on indoor or outdoor activities at their destination during their visit. If point A and point B are in different countries the Apps may also provide information on entry Visa requirements for the tourists. The concept of IoS revolves around the basic idea that systems should be able to locate useful resources online and utilise them for their application or benefit. For example, the oil company, Total, will be able to execute maintenance actions (or gain some maintenance decision support) in their new Martin Linge Field in Norway based on cloud based data service partly populated from their older Ofon Field in River Niger's delta area of Nigeria.

Smart Factory

The paradigm shift referred to as smart factories are the “end products” of the practical application of the continuing advances made in the areas of cyber-physical systems and modern ICT tools. It will constitute a key feature of Industry 4.0 [Kagermann et al. \(2013\)](#). Based on Mark Weiser's vision of ubiquitous computing [Lucke et al. \(2008\)](#) and [Zuehlke \(2010\)](#), it is convenient to identify the main components of the smart factory as calm-systems (or hardware) and the context-aware applications (software) using networking logic and advanced computing to create a virtual duplicate of physical systems. The use of sensor data from physical processes to continually update the virtual representations in real-time means that the systems are robust, resistant to disturbances and may include self-healing processes that enable it to recover from failures and thereby showing the attribute of resilience. The applicable data is processed in cyberspace through some smart algorithms in such a format as to calculate and synchronise information about the equipment's performance, risks and health conditions in real-time [Lee \(2015\)](#). The smart factory is a vision for the factory of the future where both the manufactured products and the engineered production lines form part of an intelligent system that can talk to or control each other by means of machine-to-machine (M2M) communication or other intelligent algorithms. Consciously designed, easily replaceable modules deployed on a wireless

network will enhance production processes and increase efficiency. In addition to achieving shorter product life cycles and more product variants, the smart factory environment offers improved performance, quality and system availability.

6.4 Smart Maintenance in the Context of Industry 4.0

The purpose of this section is to show how the aforementioned paradigm shifts can integrate into the concept of smart maintenance and to discuss the compatibility of the single values proposed in chapter 4 within this smart environment. The proposed smart maintenance concept (see Figure 6.3) is a system where maintenance personnel (or the production assets) no matter their location are tightly integrated into the rest of the maintenance function in particular and the entire business function in general. The onsite maintenance personnel are equipped with cutting-edge tools, including augmented reality and other innovative technologies. Remote service engineers and system analysts provide the needed interface between the maintenance back office, CMMS and the onsite engineers. This is important because the onsite engineer may have only a limited access to the cloud based services via mobile devices which are considerably more restrictive than the full compliments of computers available to the remote service engineers and other base station support staff. The production asset, onsite and remote based engineers and the operation people are all interconnected via cloud based services such as the IoT/IoS and the big data among others. There is a seamless transparency and valuable coordination between maintenance and operation. At the level of the machine, not only are the production assets able to locate and use services from the cloud automatically they are equipped with advanced sensor technologies to transform into and function as cyber-physical systems. The machines have machine-to-machine communication, machine learning and radio frequency identification capabilities. The machines are able to communicate internally, autonomously as well as provide a feedback interface to the remote human elements in the loop. Such end-to-end transparency ensures that every operational or maintenance activity is synchronised in the manner that the overarching business objective function is optimised to gain higher production throughputs.

The rotating machinery form an integral part of most production assets. Pumps, compressors, electrical motors and generators, separators, and gas turbines are common examples of

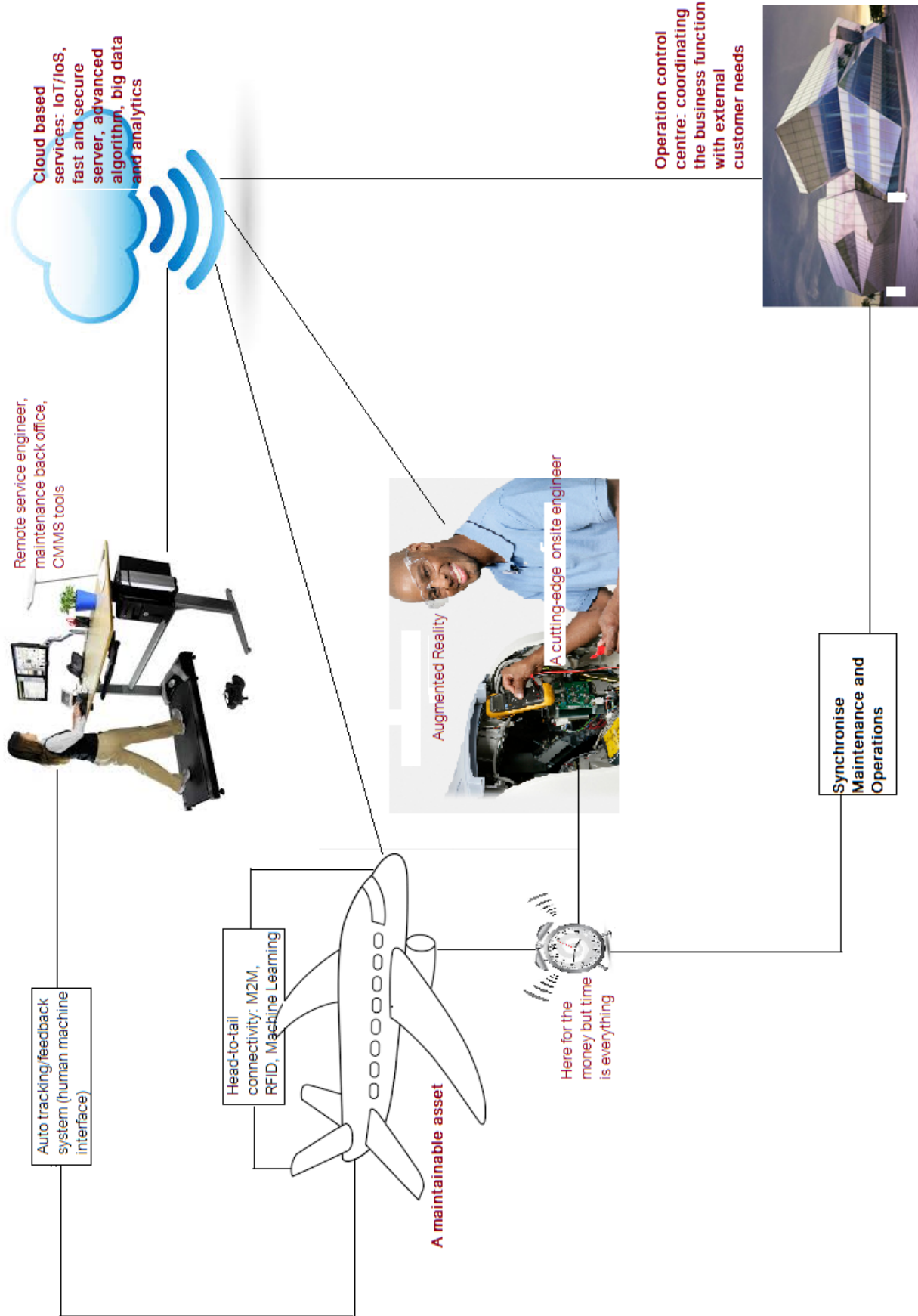

Figure 6.3: The Smart Maintenance Concept

rotating machinery used in industries. The use of vibration analysis for purposes of condition monitoring and diagnostics has been very successful within standalone systems in conventional applications. However, the concept of smart maintenance based on Industry 4.0 requires an extensive use of data. The challenge is to present the data in a format that is compatible with the design philosophies and the reference architecture for the Industrial Internet of Things (IIoT). This report has provided an initial proposal for tackling the stated challenge. It further shows a technique that makes use of structured data to implement systems prognosis based on the frequency spectrum of vibration data. The procedure outlined for implementing predictive maintenance was simple but a limited amount of data was used. That limitation makes it difficult to argue that the results obtained would be valid in all circumstances. The next phase of improvement must utilise a more extensive data coverage that would help determine the degree of accuracy of the results of the prognosis. In addition to expanding the data coverage, there is a need to calculate and provide the confidence intervals associated with every prediction. The gradual progression from condition monitoring to condition based maintenance and predictive maintenance up to prescriptive maintenance is both worthy and realisable within the sphere of smart maintenance. In order for the idea to reach a proven technology and a regulatory level of service there has to be a consciously targeted effort by all sectors to improve the techniques for measuring parameters and running the analysis. A further refinement of the ideas proposed in this report to a point of filing for a patent is recommended along with the inclusion of those partner companies who are willing to set up pilot services to validate the proposed ideas.

Chapter 7

Discussion and Conclusion

7.1 Discussion

Condition monitoring is intended to measure the current status of an operational item but it does not automatically imply that a predictive maintenance policy is in place. There has to be a system that receives the parameter values measured by the condition monitoring technique and utilise these values as an input to the predictive maintenance strategy. A condition monitoring programme is an irreducible minimum for the predictive maintenance strategy to hold but a successful predictive maintenance concept is a consciously applied policy. The evolving paradigms of the Industrial Internet of Things (IIoT) gives credence to the prediction of the 4th industrial revolution which was first identified in Germany as Industry 4.0. The disruptive nature of an industrial revolution means that there will be a shift in the general ways of doing things and there has been discussions in the maintenance engineering communities as per the impacts of these shifts in practice. The relevance of this report and the results obtained from the investigations are grounded in the reach to provide some basic proposals on how to structure and analyse vibration data for the purpose of predictive maintenance and systems prognosis. It is expected to be a means to bridge the state-of-the-art in maintenance and the future maintenance practice which is smart by its perspective and data driven by application. It was established that the frequency spectrum correctly captures the vibration energy in the rotating machinery when subjected to vibration analysis. The use of frequency peaks in spectral analysis for trending provided better results than conventional trended overall values. Spectral

analysis provides a means to separate a complex vibration time waveform into its component frequency spectra which in turn offer the benefit to identify and isolate specific frequencies resulting from each and every component in a complex rotating machine. This was traditionally used for troubleshooting and diagnosis. The investigations conducted for this thesis revealed that these frequency peaks can also be used to predict the future behavioural patterns of the rotating machinery and estimate its future vibration severity based on ordinary linear regression.

The case study used was based on data downloaded from the database of the industry partner to this thesis project. The particular data-set used for the case study came from a roller bearing which formed part of a thruster assembly on a drill ship. The relevant data used for the regression analysis had a span of eight periods. The interval between two successive periods was approximately six months. When a first order linear regression analysis was conducted based on the data from the eight periods (that is only 8 observations), a prediction model was established. From the regression analysis, the model for predicting the next period's expected vibration severity was derived as $1.096117 + 0.795704 * Y_t$ (where Y_t is the vibration severity of the most recent survey period.) The model predicted the vibration severity for period 9 as 4.96 millimetres per second. If this mathematical model is validated to hold true in similar operating conditions it becomes easy to write an algorithm that is capable of implementing system prognosis. The derived model has the limitation that it was based only on 8 observations which is grossly insufficient. The framework nonetheless provides a basis for further investigations as more data become available. With only a few data points, it was only reasonable to run a linear regression. However, in another report [Chudnovsky et al. \(2008\)](#) suggested that the quadratic model offered better results than linear ones. This report lacked sufficient data to either confirm or refute the claim that quadratic models are better than linear models. The strength of this investigation is that it has provided a proposal which can be easily adapted to create models which can be used for predictive maintenance and prognosis as the sensor technology continues to revolutionise condition monitoring whilst also driving both the big data and big data analytics for the smart maintenance applications.

7.2 Conclusions

The acceptance of two peer-reviewed papers based on this study for presentation at two international conferences is a proof of the report's originality, solidity and informativity. The derived mathematical model for predicting the future vibration severity was based on single values which are compliant with the proposed Industry 4.0 reference architecture. The vibration data stored, processed and analysed in the compliant format helps to populate the big data which in turn is used for the data driven smart maintenance with a great descriptive accuracy, predictive powers and prescriptive capabilities. Through the use of case studies, the sub-objectives of the thesis were met. Condition monitoring was shown to be a safe cost cutting mechanism. The possible approaches that can be used to integrate vibration analysis with the Industrial Internet of Things were outlined in the context of smart maintenance.

Appendix A

Acronyms

3DP Three Dimensional Printing

5S Sort, Straighten, Shine, Standardise and Sustain

AMOS Aircraft Maintenance and Engineering System

ANN Artificial Neural Network

ARMA Autoregressive Moving Average

ATA Airline Transport Association

BBN Bayesian Belief Network

CAD Computer Aided Design

CAMP Computerised Aircraft Maintenance Program

CBM Condition Based Maintenance

CC Cloud Computing

CCT Continuous on-Condition Task

CI Confidence Interval

CMMS Computerised Maintenance Management System

CPM Cycles per minute

CPS Cycles per second

CPS Cyber-Physical Systems

DDPdM Data Driven Predictive Maintenance

DoD Department of Defense

DOM Design-Out-Maintenance

ECTM Engine Condition Trend Monitoring

EFFRA The European Factories of the Future Research Association

EUC Equipment Under Consideration

FFA Functional Failure Analysis

FFT Fast Fourier Transform

FMEA Failure Mode and Effects Analysis

FMECA Failure Mode, Effects and Criticality Analysis

FoF Factories of the Future

FOM Force of Mortality

FRACAS Failure Reporting, Analysis, and Corrective Action System

GTE Gas Turbine Engine

IaaS Infrastructure as a Service

ICT Information & Communications Technology

IMS Inventory Management System

IoS Internet of Services

IoT Internet of Things

IP Internet Protocol

IR infra red

ISO International Standards Organisation

KET Key Enabling Technology

KPI Key Performance Indicator

LCC Life Cycle Cost

LCP Life Cycle Profit

M2M machine-to-machine

MCA Motor Circuit Analysis

MiRA The Mixed Reality Application

MSI Maintenance Significant Item

MTBR Mean Time Between Repair

MTTF Mean Time To Failure

MTTR Mean Time To Repair

NIST National Institute of Standards and Technology

NTNU Norges Teknisk-Naturvitenskapelige Universitet (Norwegian University of Science & Technology)

OEE Overall Equipment Effectiveness

OEM Original Equipment Manufacturer

PaaS Platform as a Service

PDCA Plan-Do-Check-Adjust

PdM Predictive Maintenance

PM Preventive Maintenance

PPP Public Private Partnership

R & D Research & Development

R & I Research & Innovation

RAC Reliability Analysis Center

RAMS Reliability, Availability, Maintainability and Safety

RCM Reliability Centred Maintenance

rms root mean square

RPM revolutions per minute

RTF Run to Failure

SAP Systems Applications and Products

SCT Scheduled on-Condition Task

SFT Scheduled Function Test

SOA Service-oriented architecture

SOH Scheduled Overhaul

SRP Scheduled Replacement

TPM Total Productive Maintenance

TQM Total Quality Management

TSN Time Since New

US ultra sound

VFD Variable-Frequency Drive

Appendix B

Figures from the ISO 10816-1:1995(E) and Karsten Moholt

B.1 General form of vibration velocity acceptance criteria

**B.2 Comparison of vector change and change in magnitude for
a discrete frequency component**

B.3 Vibration analysis flow chart

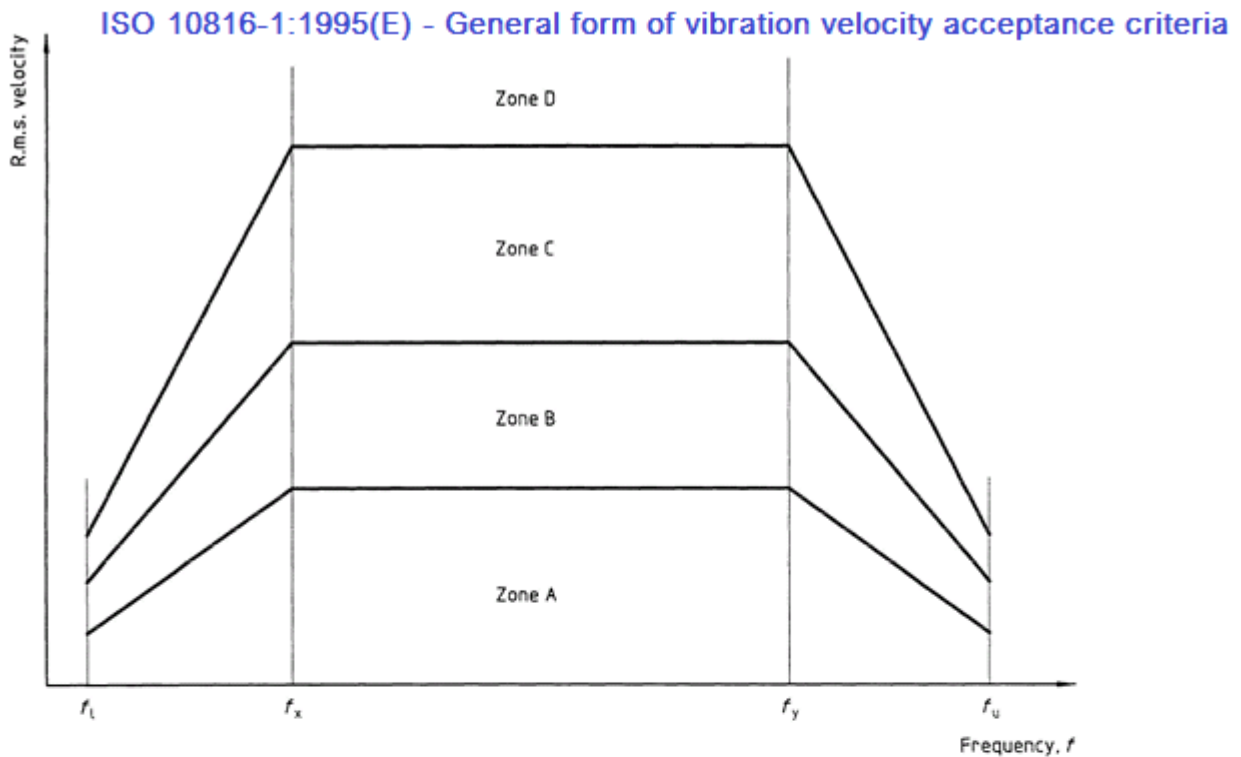

For many machines, the broad-band vibration consists primarily of a single frequency component, often shaft rotational frequency. In this case, the allowable vibration is obtained from figure 6 as the vibration velocity corresponding to that frequency.

For less-common machines, where there may be significant vibratory energy beyond the breakpoints f_x and f_y of figure 6, a number of different approaches are possible. Examples are the following.

- a) In addition to the usual broad-band velocity, broad-band displacement may be measured when there is significant energy below f_x . Similarly, broad-band acceleration may be measured when there is significant energy above f_y . The allowable vibration displacement and acceleration should be consistent with the velocity corresponding to the sloped portions of figure 6.
- b) The velocity, displacement or acceleration at each significant component throughout the frequency spectrum may be determined using a frequency analyser. The equivalent broad-band velocity can be obtained using equation (A.2) after applying

appropriate weighting factors, consistent with figure 6, for those components whose frequencies are below f_x or above f_y . This value should then be evaluated relative to the constant velocity between f_x and f_y . It should be noted that, except for the case when the broad-band vibration consists primarily of a single frequency component, a direct comparison of the frequency spectrum components with the curves of figure 6 would yield misleading results.

- c) A composite broad-band measurement encompassing the entire spectrum may be carried out using an instrument incorporating weighting networks consistent with the shape of figure 6. This value should then be evaluated relative to the constant velocity between f_x and f_y .

The evaluation criteria for specific machine types will be given in the additional parts of ISO 10816 as they become available. Annex C provides additional guidance. For certain machine types, it may be necessary to define further criteria beyond those described by figure 6 (see for example, 5.6.3).

Figure B.1: General form of vibration velocity acceptance criteria

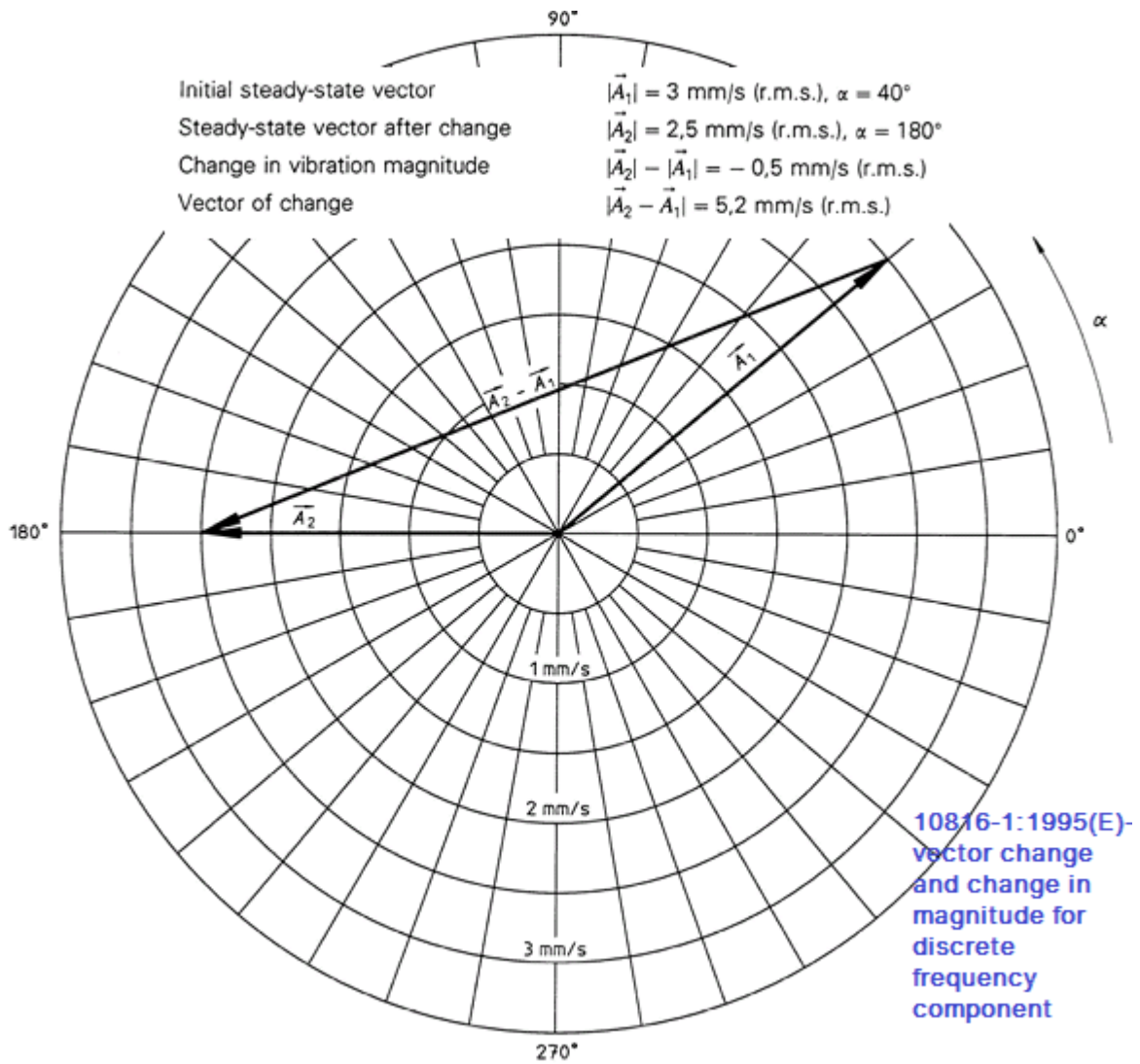
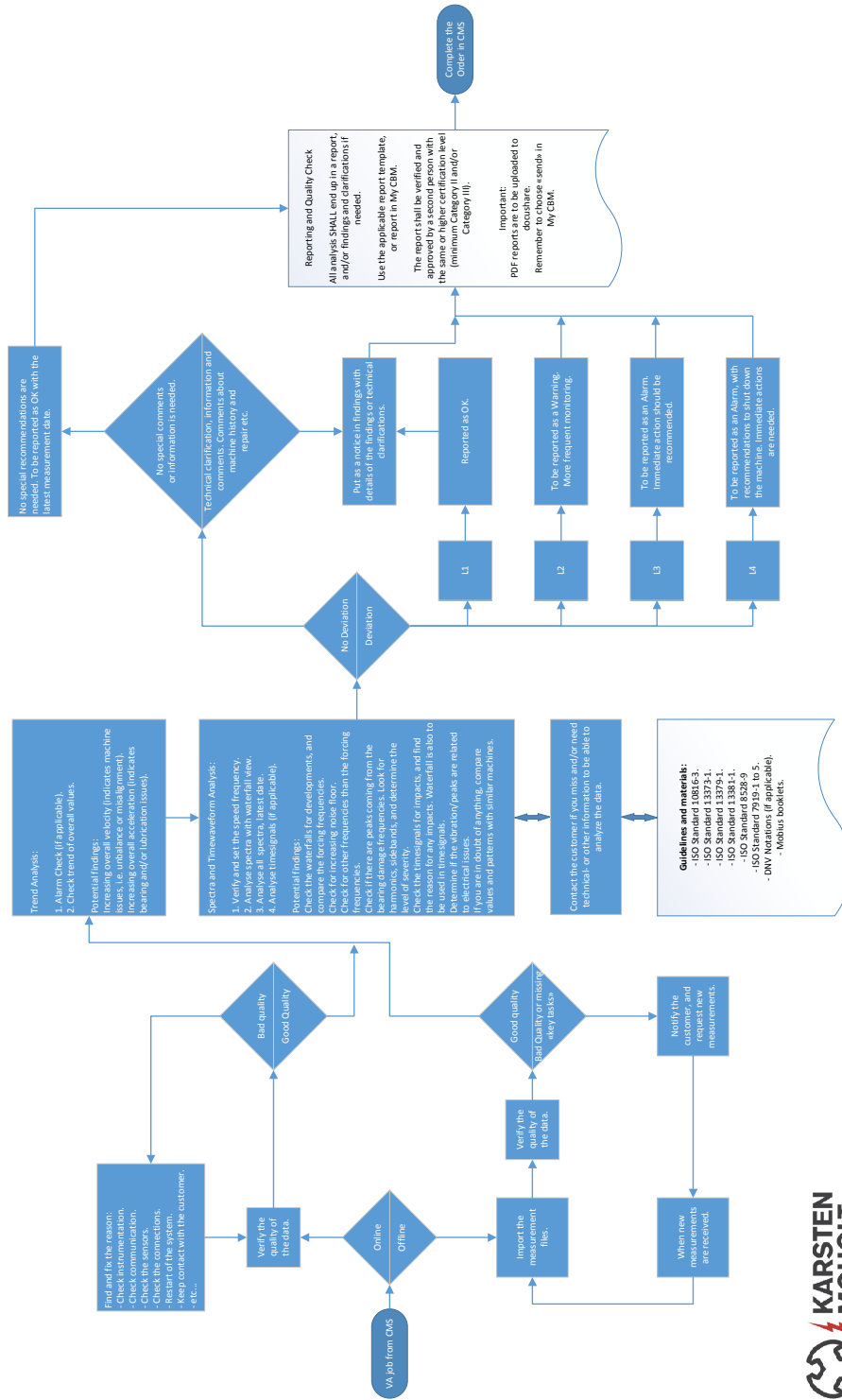

Figure B.2: Comparison of vector change and change in magnitude for a discrete frequency component

VIBRATION ANALYSIS FLOW CHART



Rev.01, Bård Kausland, 27.11.2015



Figure B.3: Vibration analysis flow chart

Bibliography

Abrahart, R. J. and See, L. (2000). Comparing neural network and autoregressive moving average techniques for the provision of continuous river flow forecasts in two contrasting catchments. *Hydrological processes*, 14(11-12):2157–2172.

ATA (2001). *The Airline Handbook*. Air Transport Association of America.

Attardi, L., Guida, M., and Pulcini, G. (2005). A mixed-weibull regression model for the analysis of automotive warranty data. *Reliability Engineering & System Safety*, 87(2):265–273.

Bai, H., Ma, Z., and Zhu, Y. (2012). The application of cloud computing in smart grid status monitoring. In *Internet of Things*, pages 460–465. Springer.

Borgan, Ø. (2005). Kaplan–meier estimator. *Encyclopedia of biostatistics*.

BS-5760-5 (1996). British standard: Reliability of constructed or manufactured products, systems, equipments and components.

Chudnovsky, B. H., Livshitz, A., and Chudnovsky, B. A. (2008). Thermal model of electrical contacts based on experimental data. In *2008 Proceedings of the 54th IEEE Holm Conference on Electrical Contacts*, pages 205–211. IEEE.

Chukwuekwe, D., Schjølberg, P., Harald, R., and Alex, S. (2016). Reliable, robust and resilient systems: Towards development of a predictive maintenance concept within the industry 4.0 environment. In *24th Biennial Euro Maintenance Conference*, pages 1–11. EFNMS.

EN-13306 (2010). Maintenance terminology standards.

- Evans, P. C. and Annunziata, M. (2012). Industrial internet: Pushing the boundaries of minds and machines. *General Electric*, page 21.
- Fessler, J. A. and Sutton, B. P. (2003). Nonuniform fast fourier transforms using min-max interpolation. *IEEE Transactions on Signal Processing*, 51(2):560–574.
- Gabbar, H. A., Yamashita, H., Suzuki, K., and Shimada, Y. (2003). Computer-aided rcm-based plant maintenance management system. *Robotics and Computer-Integrated Manufacturing*, 19(5):449–458.
- IEC-60812 (1985). Analysis techniques for system reliability – procedures for failure mode and effect analysis (fmea).
- ISO10816-1, I. (1995). Iso 10816-1: Mechanical vibration—evaluation of machine vibration by measurements on non-rotating parts—part 1: General guidelines. *ISO, Switzerland*.
- ISO10816-3, I. (2009). Iso 10816-3: Mechanical vibration—evaluation of machine vibration by measurements on non-rotating parts—part 3: Industrial machines with nominal power above 15 kw and nominal speeds between 120 r/min and 15,000 r/min when measured in situ iso. *ISO, Switzerland*.
- ISO7919-1, I. (1996). Mechanical vibration of non-reciprocating machines - measurements on rotating shafts and evaluation criteria—part 1: General guidelines. *ISO, Switzerland*.
- Kagermann, H. et al. (2013). Recommendations for implementing the strategic initiative industrie 4.0.
- Khashei, M., Bijari, M., and Ardali, G. A. R. (2009). Improvement of auto-regressive integrated moving average models using fuzzy logic and artificial neural networks (anns). *Neurocomputing*, 72(4):956–967.
- Kuemlee, H., Gross, T., and Kolerus, J. (2013). Machine vibrations and diagnostics the world of iso. In *Industry Applications Society 60th Annual Petroleum and Chemical Industry Conference*, pages 1–13. IEEE.

- Lee, E. et al. (2008). Cyber physical systems: Design challenges. In *Object Oriented Real-Time Distributed Computing (ISORC), 2008 11th IEEE International Symposium on*, pages 363–369. IEEE.
- Lee, J. (2015). Smart factory systems. *Informatik-Spektrum*, pages 1–6.
- Lim, W., Zhang, D., Zhou, J., Belgi, P., and Chan, H. (2010). Vibration-based fault diagnostic platform for rotary machines. In *IECON 2010-36th Annual Conference on IEEE Industrial Electronics Society*, pages 1404–1409. IEEE.
- Lindqvist, B. H. (2006). On the statistical modeling and analysis of repairable systems. *Statistical science*, pages 532–551.
- Lindqvist, B. H. and Doksum, K. A. (2003). *Mathematical and statistical methods in reliability*, volume 7. World Scientific.
- Lindqvist, B. H. and Langseth, H. (2005). Statistical modelling and inference for component failure times under preventive maintenance and independent censoring. *Modern Statistical and Mathematical Methods in Reliability (Wilson A, Limnios N, Keller-McNulty S, Armijo Y)*. World Scientific Publishing, Singapore, pages 323–337.
- Lu, B., Li, Y., Wu, X., and Yang, Z. (2009). A review of recent advances in wind turbine condition monitoring and fault diagnosis. In *Power Electronics and Machines in Wind Applications, 2009. PEMWA 2009. IEEE*, pages 1–7. IEEE.
- Lucke, D., Constantinescu, C., and Westkämper, E. (2008). Smart factory-a step towards the next generation of manufacturing. In *Manufacturing Systems and Technologies for the New Frontier*, pages 115–118. Springer.
- Manyika, J., Chui, M., Brown, B., Bughin, J., Dobbs, R., Roxburgh, C., and Byers, A. H. (2011). Big data: The next frontier for innovation, competition, and productivity.
- Márquez, F. P. G., Tobias, A. M., Pérez, J. M. P., and Papaelias, M. (2012). Condition monitoring of wind turbines: Techniques and methods. *Renewable Energy*, 46:169–178.

- McInerny, S. A. and Dai, Y. (2003). Basic vibration signal processing for bearing fault detection. *IEEE Transactions on education*, 46(1):149–156.
- Meeker, W. Q. and Escobar, L. A. (2014). *Statistical methods for reliability data*. John Wiley & Sons.
- Mell, P. and Grance, T. (2011). The nist definition of cloud computing.
- MIL-STD-1629A (1980). Procedures for performing a failure mode, effects and criticality analysis.
- MIL-STD-2155 (1985). Procedures for performing a failure mode, effects and criticality analysis.
- Mobley, R. K. (2002). *An introduction to predictive maintenance*. Butterworth-Heinemann.
- Okoh, P. and Haugen, S. (2013). Maintenance-related major accidents: classification of causes and case study. *Journal of Loss Prevention in the Process Industries*, 26(6):1060–1070.
- Pascual, F. G. and Montepiedra, G. (2005). Lognormal and weibull accelerated life test plans under distribution misspecification. *IEEE Transactions on Reliability*, 54(1):43–52.
- Peng, C.-Y. and Tseng, S.-T. (2009). Mis-specification analysis of linear degradation models. *IEEE Transactions on Reliability*, 58(3):444–455.
- Rao, B. (1996). *Handbook of condition monitoring*. Elsevier.
- Rausand, M. (2014). *Reliability of Safety-Critical Systems: Theory and Applications*. Wiley, Hoboken, NJ.
- Rausand, M. and Høyland, A. (2004). *System Reliability Theory: Models, Statistical Methods, and Applications*. Wiley, Hoboken, NJ, 2nd edition.
- Rausand, M. and Vatn, J. (2008). Reliability centred maintenance. In *Complex system maintenance handbook*, pages 79–108. Springer.
- Reason, J. T. and Reason, J. T. (1997). *Managing the risks of organizational accidents*, volume 6. Ashgate Aldershot.

- SAE-ARP-5580 (2001). Recommended failure modes and effects analysis (fmea) practices for non-automobile applications.
- Scheffer, C. and Girdhar, P. (2004). *Practical machinery vibration analysis and predictive maintenance*. Elsevier.
- Schroth, C. and Janner, T. (2007). Web 2.0 and soa: Converging concepts enabling the internet of services. *IT professional*, 9(3):36–41.
- Simeu-Abazi, Z. and Bouredji, Z. (2006). Monitoring and predictive maintenance: Modeling and analysis of fault latency. *Computers in industry*, 57(6):504–515.
- Vatn, J. (2007). Maintenance optimisation (ntnu lecture compendium).
- Wang, W. (2008). Condition-based maintenance modelling. In *Complex system maintenance handbook*, pages 111–131. Springer.
- Wilson, A. (2002). *Asset maintenance management: a guide to developing strategy & improving performance*. Industrial Press Inc.
- Wilson, A. (2013). *Asset Management: focusing on developing maintenance strategy and improving performance*. Conference Communication.
- Yan, L., Zhang, Y., Yang, L. T., and Ning, H. (2008). *The Internet of things: from RFID to the next-generation pervasive networked systems*. CRC Press.
- Zaal, T. M. and Newton, S. (2011). *Profit-driven maintenance for physical assets*. Maj Engineering Publishing.
- Zuehlke, D. (2010). Smartfactory—towards a factory-of-things. *Annual Reviews in Control*, 34(1):129–138.

Resume

Name: **Douglas Okafor Chukwuekwe**
Gender: Male
Date of birth: March 11, 1979
Address: Hårstadreina 2B, Tiller, 7092 Trondheim, Norway
Home address: Block 60 Flat 2, Ojokoro Estate, Ijaiye–Lagos, Nigeria
Nationality: Nigerian
Email (1): douglas.o.chukwuekwe@ntnu.no
Email (2): douglasco@engineer.com
Telephone: +47 457 94 884, +234 803 382 8105



Language Skills

English: Full professional proficiency
Igbo: Native or bilingual proficiency
Norwegian: Elementary proficiency

Education

- Norwegian University of Science and Technology (NTNU), Trondheim – MSc in RAMS
- Nigerian College of Aviation Technology, Zaria – Diploma in Aircraft Maintenance
- Nnamdi Azikiwe University, Awka – BEng in Electrical/Electronics Engineering

Computer Skills

- Minitab, Latex and Microsoft packages
- Cara Fault Tree and Omnitrend
- Matlab/Simulink
- DIgSILENT Power Factory

Experience

- Research Assistant – 2015 summer job at the NTNU
- Teaching Assistant – NTNU courses (TPK4120, TPK4140 and TPG4200)
- Member of the Reference Group in TPK4140, TPK5160, TPG4200, TPK4126 and TPK5170
- President of International Students' Union of Norway, ISU – Trondheim Local Chapter
- National Chairman of International Students' Union of Norway, ISU – Norway
- Member of the Board, Industri Energi NTNU-Trondheim
- Member of the NTNU Students' Parliament (2014 – 2015)
- Aircraft Maintenance Engineer – Arik Air Limited (2007 – 2014)
- Production & Planning Engineer – Bellview Airlines Limited (2005 – 2007)

Hobbies and Other Activities

- Reading, football, swimming and table tennis

Intentionally left blank

Part 2: Peer-Reviewed Papers

Paper ONE



EURO
MAINTENANCE 2016

30 May - 1 June 2016

Athens Ledra Hotel

Athens, Greece

www.euromaintenance2016.org

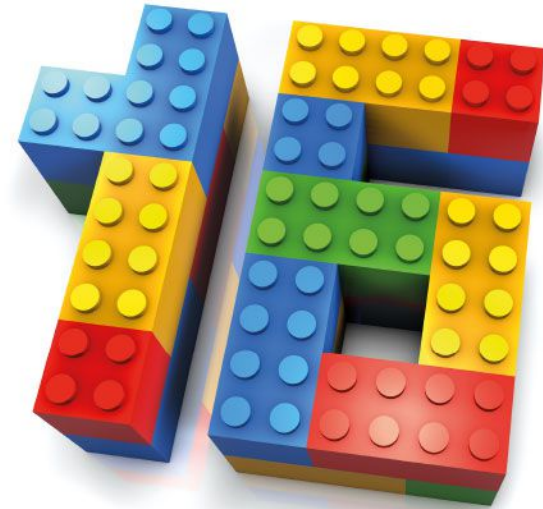

Title:

Reliable, Robust and Resilient Systems: Towards
Development of a Predictive Maintenance Concept within
the Industry 4.0 Environment

Speaker:

Douglas Okafor Chukwuekwe



NTNU

Norwegian University of
Science and Technology

Organisers

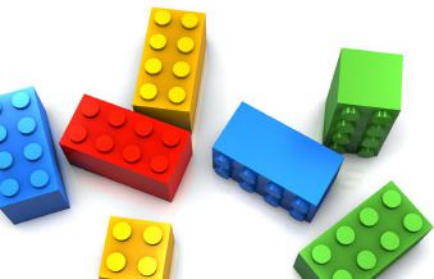

Outline:

- Industry 4.0: What is it?
- Key Enabling Technologies (KETs)
- Smart Things Everywhere, Even Smart Maintenance
- The Maintenance Evolution within an Industrial Revolution
- Key Benefits and some Challenges
- Summary & Conclusions



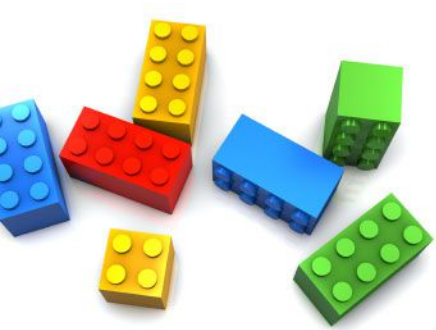

Industry 4.0: What is it?

Industrial Revolutions						Hierarchy of human needs	
???				Apocalypse		???	
5th ?			Intuitive Machine	Self-actualisation		5th	
4th			Use of Cyber-physical systems	Esteem		4th	
3rd			Use of programmable electronics & IT	Networking and friendship		3rd	
2nd			Electrical energy, mass production & div. of labour	Safety needs		2nd	
1st			Water/steam powered mechanical production equipment	Physiological needs, e.g. clothing and shelter		1st	
	1800	1900	1970	Today	Future		Undefined continuum

- Focus on the manufacturing sector
- Mass customization (extreme case = lot size 1)
- Smart systems plus high performance computing interfaced with humans or other intelligent agents



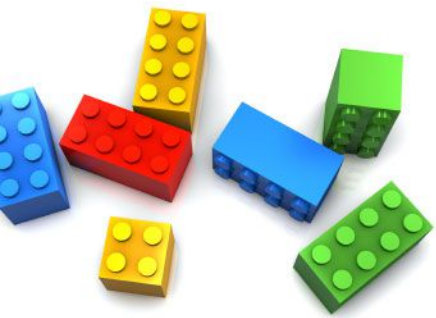

Reliable, Robust and Resilient Systems: Towards Development of a Predictive Maintenance Concept within the Industry 4.0 Environment



From Spinning Machines to the Industrial Internet of Things (IIoT)

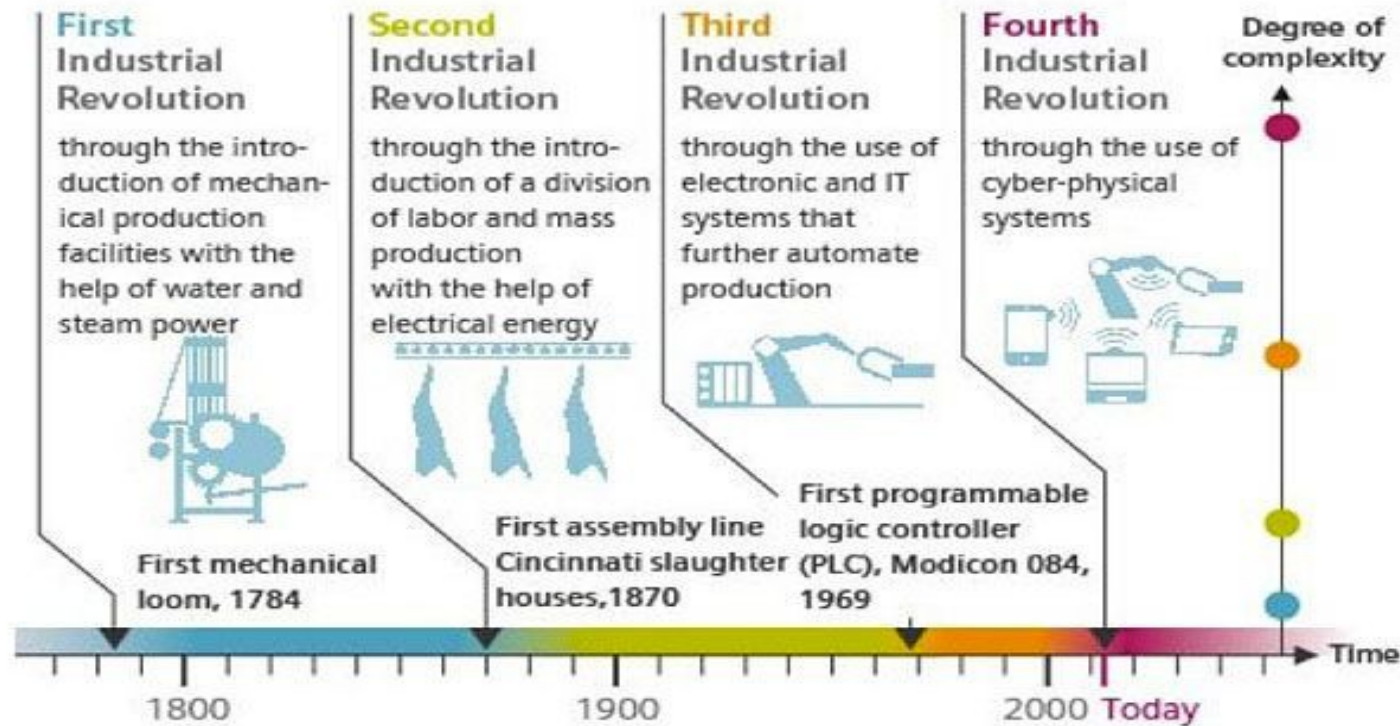



Key Enabling Technologies:

- Big Data
 - Aggregated small data e.g. from sensors
 - Data analytics and data science
 - Value added for smart/predictive maintenance
- Cloud Computing
 - A cluster of services with the following compositions:
 - ✓ 5 essential xtics (On-demand self-service, Broad network access, Resource pooling, Rapid elasticity, Measured service)
 - ✓ 3 service models (Software as a Service (SaaS), Platform as a Service (PaaS), Infrastructure as a Service (IaaS))
 - ✓ 4 deployment models (Private cloud, Community cloud, Public cloud, and Hybrid cloud)
- 3D Printing
 - Meet need to generate design iterations
 - Create cheap metal parts directly from a CAD file
 - Concept modelling
 - Rapid prototyping



Key Enabling Technologies:

- Internet of Services (IoS)
 - Internet of data → Internet of information → IoS
 - Loosely coupled services often based on web service interface/service oriented architecture (SOA)
 - Locate useful resources online and utilize them for specific applications (e.g., for predictive maintenance)
- Internet of Things (IoT)
 - Pervasive network society connecting a lot of objects
 - Each device has a unique IP address
- Cyber-Physical Systems (CPS)
 - Integration of computation and physical processes
 - Tight and definite link between the cyberspace and the physical worlds
 - Provides systems ability to communicate and control one another in a collaborative manner
 - Well suited to provide early warnings and useful for PdM applications



Smart Things Everywhere, even Smart Maintenance:

- An era of cheap, smart sensors
- Ubiquitous computing
- Virtual duplicates of physical systems/processes
- Consciously designed, easily replaceable modules deployed over wireless networks
- Transition from embedded systems to cyber-physical systems
- Evolution from machines embedded with software to software “embedded” with machines



**Equal pay
for equal
work,
welcome
the
Robots!**



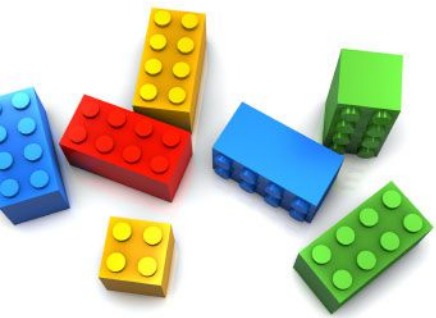

The Maintenance Evolution in an Industrial Revolution:

Maintenance Philosophies:

- Corrective Maintenance → Run to failure
- Preventive Maintenance → Planned maintenance based on the assumption that every equipment will fail at some points!
- Predictive Maintenance → Based on condition monitoring and following some predefined rules and strategies

Future Maintenance:

- Data driven versus model based (a novel combination of both)
- Greatly influenced by value added data
- Diagnostics: Industry 3.0 machines featured BITEs but no system to add value to the measurements or the symptoms detected
- The future is closed loop, feedback system with a prediction capability
- Improved system knowledge, better work place safety, greater resource and energy efficiencies.



A Conceptual Model for the Data Driven, Closed Loop, Feedback Predictive Maintenance System:

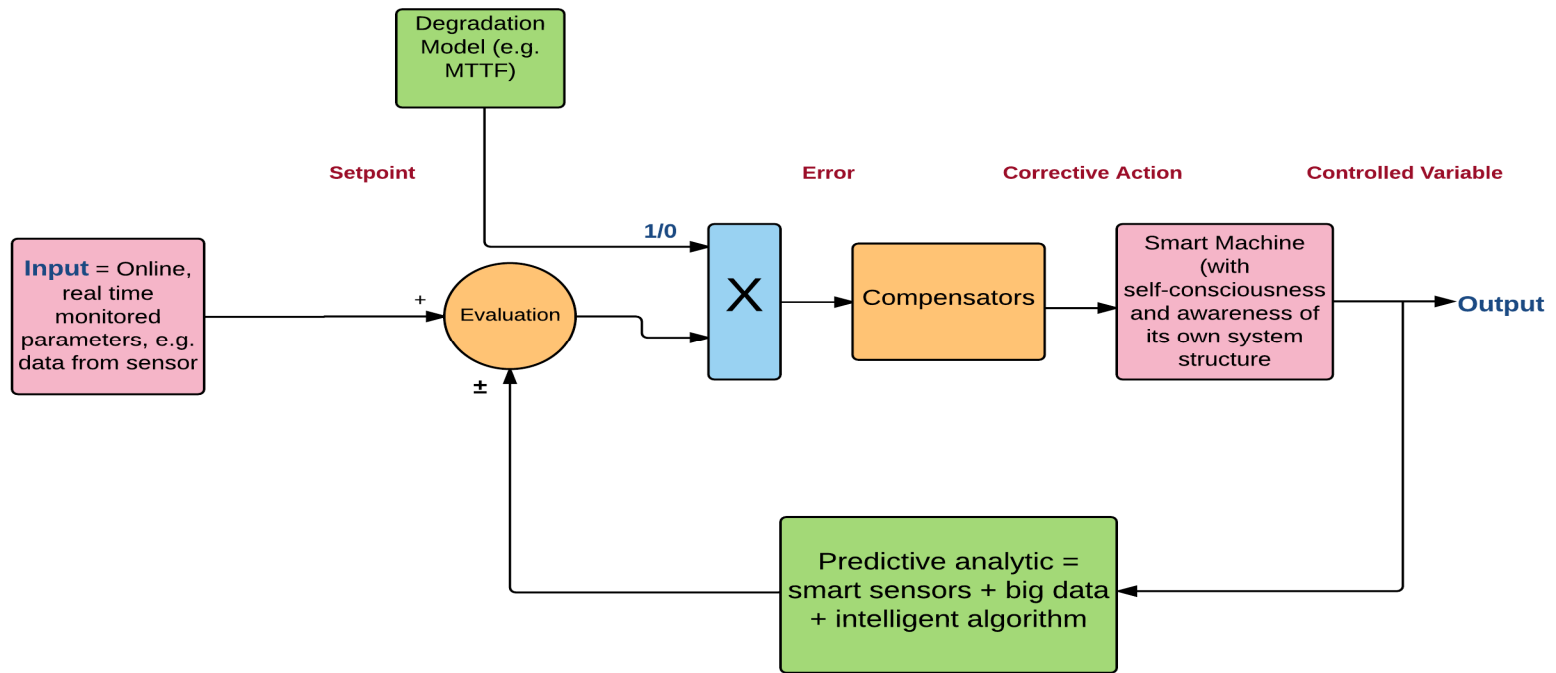

Reliable, Robust and Resilient Systems: Towards Development of a Predictive Maintenance Concept within the Industry 4.0 Environment

Prognosis

- Pattern identification
- Trending
- Continuous monitoring, data mining and repeated analysis
- Accumulated system knowledge and intelligent analytics
- Possibility for more accurate EoL and RUL estimations
- Feedback through a closed loop system
- Cloud based service platforms for data storage and analysis
- Integration with augmented reality, artificial neural networks, or the hidden Markov Chain, etc

sharing

- Machine to machine and machine learning algorithms to reinforce systems characteristics
- Creation of new business models, sale of data for revenue

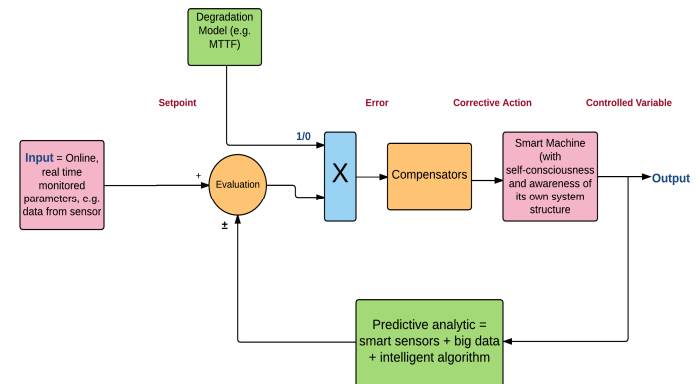

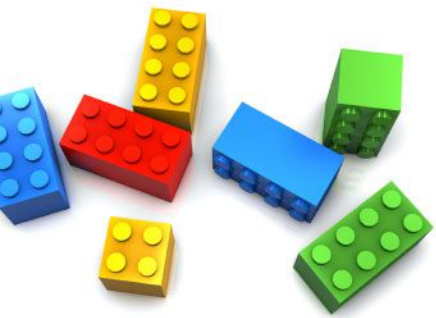

Key Benefits and some Challenges:

- Multi dimensional system characteristics improvements: reliability, robustness and resilience

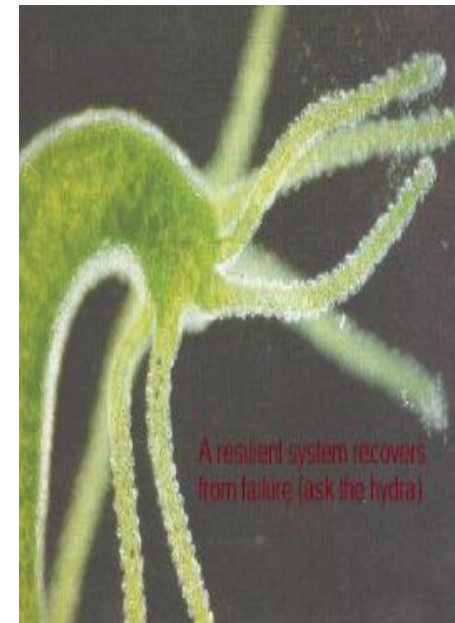

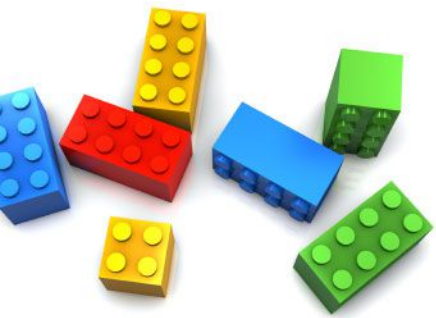

More Benefits:

- Dramatic reduction in the probability of a sudden loss of system function
- An “only as required” maintenance strategy results in better safety performance and higher equipment availability
- Improved productivity and profitability

Some Challenges:

- Many of the technologies used are not proven
- Who owns the generated data?
- Can we really ever bet on the security of the network?
- More research and more funds



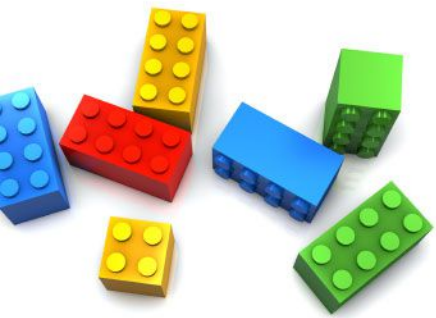

Summary & Conclusions

- Presented an overview of Industry 4.0 and its key drivers
- Demonstrated how maintenance is expected to evolve within this shifting paradigm
- Proposed a basic structure for a data-driven predictive maintenance framework
- Argued for some benefits to credit the proposed framework and highlighted a few challenges.



Reliable, Robust and Resilient Systems: Towards Development of a Predictive Maintenance Concept within the Industry 4.0 Environment



Thank you for listening



Reliable, Robust and Resilient Systems: Towards Development of a Predictive Maintenance Concept within the Industry 4.0 Environment

Douglas Okafor Chukwueke¹, Per Schjøberg², Harald Rødseth³, Alex Stuber⁴

¹ Department of Production and Quality Engineering, NTNU, Norway, douglasco@engineer.com

² Department of Production and Quality Engineering, NTNU, Norway, per.schjolberg@ntnu.no

³ Department of Production and Quality Engineering, NTNU, Norway, harald.rodseth@ntnu.no

⁴ Academic Research & Education Network (AREN), Switzerland, astuber@aspartner.ch

Keywords – Big data, CPS, IoT, Prognosis, Smart Factory

Abstract

The world is at the threshold of yet another industrial revolution. It is the 4th industrial revolution presently being promoted as “Industry 4.0” in Germany or “Advanced Manufacturing” in the USA. Both ideas are similar, in essence, they refer to smart systems and high performance computing interfaced with people. It was previously dismissed as science fiction at its best but there are now a few visible elements of Industry 4.0 in practice. However the concept is still in its formative stage and would take an extensive troubleshooting and fine-tuning to eventually come of age. The disruptive nature of an industrial revolution means that it will affect our general ways of life and means of livelihood. This paper reviews the major technological drivers (such as big data, cloud computing, cyber-physical systems, Internet of Things and Internet of Services) leading up to Industry 4.0 and presents Smart Factory as its core beneficiary. The paradigm shift driven by cheap and powerful sensors/actuators, enhanced man-machine interaction and ubiquitous computing will result in a new approach to the maintenance of physical assets. The challenge with routine or time-based maintenance philosophies is that they have potential to drive the cost of maintenance steeply upwards. Predictive maintenance can cut maintenance down only to the level necessary. It is however not easy to determine this “necessary” level but in the proposed Industry 4.0 reference architecture it is important to factor in maintenance from the early design stages of equipment fabrication, assembly or integration so that systems can benefit from predictive analytics. Thus, the paper further presents a conceptual framework for the development of a predictive maintenance technique using big data mining and smart algorithms. The significance is that

designers will gain some insights to reach the ultimate goal of reliable, robust and resilient systems offering equipment operators improved life cycle benefits.

1. Introduction

The constant evolution of science means that it continues to break new frontiers and reach new horizons. The current hype about Industry 4.0 (Industrie 4.0 Working Group, 2013) has led to some doubts and generated several debates within the industry as well as the academia. It is noted that unlike its three predecessors (Figure 1), Industry 4.0, commonly called the fourth industrial revolution, is different from previous industrial revolutions because it is orchestrated through a consciously pursued effort which in effect ‘forces’ its actual manifestation to speed up. The orchestration of Industry 4.0 has been a joint collaboration between government agencies, the industry, research and academic institutions. Germany and the USA are clearly in the lead to bring about this next evolution in technological applications though the Americans prefer the term “advanced manufacturing.” There are equally other terms in common use such as “Industrial Internet” (Evans & Annunziata, 2012) or intelligent factories but the basic ideas are in sync with Industry 4.0, in essence, embodying smart systems and high performance computing interfaced with people.

Industry 4.0 is a strategic initiative that aims to radically combine manufacturing, automation and information & communications technology (ICT) into a vertical network within one entity, network two or more of such entities in a horizontal chain to create organisational transparency and seamless production. However novel, Industry 4.0 is not meant to be a tsunami that would sweep away everything we already know overnight and

replace it with a brand new system instead it would be an incremental development that would survive through a period of transition based on two main approaches. First, design effort aimed at bridging the gap between Industry 3.0 practices and Industry 4.0 ideas by adapting, modifying and retrofitting that would take us initially to the midpoint Industry 3.5. Second, pursuing a fully innovative design concept based on the proposed Industry 4.0 reference architecture. Result from previous study by Industrie 4.0 Working Group, 2013 identified standardisation, work organisation and product availability as the three major challenges facing the implementation of Industry 4.0. Product availability is not only a function of operation and maintenance it also depends on the system's characteristics such as its reliability, robustness and resilience. In the next phase of manufacturing evolution, the importance of these characteristics for equipment effectiveness will become more evident. Operators will place more emphasis on their desire that engineered systems should exhibit certain characteristic properties, e.g., that they seldom fail (reliability), be able to perform in the presence of noise and remain elastic under changing load (robustness); and autonomously recover from fault or failure situations (resilience). Through the application of big data mining techniques and smart algorithms following the iteration concept proposed in this paper, designers can achieve such system characteristics. In the current paper, predictive maintenance strategies are considered in the context of Industry 4.0, but the approaches advanced here will be influenced partly by current practices. In the general scope, asset integrity engineering and maintenance management encompass the development of a maintenance programme in line with production forecast, asset utilization and best practices; dealing with inventory management and logistic issues, developing action plans to close previous findings such as may have resulted from routine inspections, condition monitoring, etc. Today's industrial environments aspire to optimize multiple objectives and apply the computerized maintenance management systems, CMMS, tools to their benefit. Successful implementations of the Intelligent Maintenance System (IMS), Failure Reporting, Analysis, and Corrective Action System (FRACAS), production planning automation and allied advanced maintenance tools historically depended on the use of the CMMS. The Industry 4.0 engineered environment will take the integration to a higher level and provide a common platform to combine disparate tools and create transparency across board.

The objective of the paper is to propose concepts for predictive maintenance and prognosis within an industry 4.0 environment and review how the key drivers such as cloud computing, smart factory, Cyber-physical systems, Internet of Things, Internet of Services, Big Data, etc can influence and shape the maintenance management of the future. This is expected to improve product availability and guarantee asset integrity. The paper is structured as follows: Section 2 presents basic materials on the key drivers of Industry 4.0 and gives some backgrounds; Section 3 presents the new approach within Industry 4.0 referred to as the smart factories; Section 4 proposes a theoretical conceptual framework for implementing a data driven predictive maintenance system within Industry 4.0 environments; Section 5 states some credits for the proposed predictive maintenance structure and highlights key challenges and recommended actions to overcome current limitations; Section 6 concludes the paper with some insights.

2. From Spinning Machines to Industry 4.0: The Trends and Drivers of an Industrial Evolution

The first industrial revolution started in the late 1700s (Figure 1, left hand side) following the introduction of the spinning machine, conveyor belt, and other machinery powered by water or steam used mainly in the textile factories of that era. It sounds valid to argue that the first industrial revolution addressed some of man's physiological needs, increased food production through mechanized agriculture and clothing from the textile industries (Figure 1, right hand side). Subsequent industrial revolutions equally showed links with the Abraham Maslow's hierarchy of needs (Thielke, et al 2011). The second industrial revolution which started at the dawn of the 20th century was characterised by the use of electrical machines for mass production and the division of labour. This offered humanity both safety and security. The third industrial revolution, sometimes referred to as the digital revolution, began at the early 1970s with the increased automation of manufacturing processes using advanced electronics and ICT (information and communication technology) techniques which led to a better man-machine interface over process networks. Technologies however evolve in a continuous way. Today, the world has reached the threshold of yet another industrial revolution. Below we present a brief discussion on the key technological drivers leading to Industry 4.0.

1.1 Big Data

Big data has been the going concern of many companies since the advent of the social media but the eventual implementation of Industry 4.0 will inadvertently lead to an actual data explosion resulting from machine generated big data.

Industrial Revolutions					Hierarchy of human needs				
1800	1900	1970	Today	Future	1st	2nd	3rd	4th	5th
					1st	2nd	3rd	4th	5th
					Physiological needs, e.g. clothing and shelter	Safety	Networking and friendship	Esteem	Self-actualisation
									Apocalypse
									Intuitive Machine
									Use of Cyber-physical systems
									Use of programmable electronics & IT
									Electrical energy, mass production & div. of labour
									Water/steam powered mechanical production equipment
									Undefined continuum
									???
									???
									5th ?
									4th
									3rd
									2nd
									1st

Figure 1: Drawing a parallel between industrial revolutions and man's instincts for survival

In that context, we will liken big data to cassava root or yucca which until it has been processed remains useless or even harmful no matter how succulent it appears to the owner. Big data

analytics will become an important field with business opportunities in the future. Big data will be at the core of predictive maintenance concept development within the Industry 4.0 environment but it has to be processed and analysed. There is no doubt that advanced analytics can greatly enhance decision-making quality. Big data is generated from small data obtained from sensors embedded into products such as subsea valves or automobile wheels to measure some desired physical quantities like temperature or flow-rate which are in turn analysed to support decision-making including maintenance decisions. A Boeing 737 NextGen airplane for example will generate about 240 terabytes of data during a one hour flight between two airports. These sensor data if properly analysed can provide good insight into the state of health of the airplane, its exposure to risk or its level of performance and help the airline operator to prioritise maintenance decisions in a proactive manner (Manyika, et al 2011).

1.2 Cloud Computing

Industry 4.0 will leverage on existing technologies such as cloud computing which actually is a cluster of services (Bai, et al 2012). In relation to services, the discussion will be expanded further in the next paragraph dealing with the Internet of Services. The definition of cloud computing is rather cloudy perhaps because it is an evolving paradigm. However, the definition provided by the National Institute of Standards and Technology (NIST) is though not perfect but it is good enough for today's use. Cloud computing is a model for enabling ubiquitous, convenient, on-demand network access to a shared pool of configurable computing resources (e.g., networks, servers, storage, applications, and services) that can be rapidly provisioned and released with minimal management effort or service provider interaction (Mell & Grance, 2011). It identified the three main components of this cloud model to have the following compositions:

- Five essential characteristics (On-demand self-service, Broad network access, Resource pooling, Rapid elasticity, Measured service);
- Three service models (Software as a Service (SaaS), Platform as a Service (PaaS), Infrastructure as a Service (IaaS)); and
- Four deployment models (Private cloud, Community cloud, Public cloud, and Hybrid cloud).

1.3 Internet of Services (IoS)

The Internet of data evolved into the Internet of information which has now largely developed into the Internet of Services (IoS). Web service interface and the service-oriented architecture (SOA) are the key drivers of the concept of loosely coupling services used either for technological or business purposes (Schroth & Janner, 2007). The application services available on these platforms will connect people, objects and systems and further possess specific features such as adaptability, support for collaborative use and diverse mobile end devices, process deployment along the lines of the App stores model, and should provide safety, security and reliability guarantee (Industrie 4.0 Working Group, 2013). This can be illustrated using a human-system or system-system interaction. For example, if a group of tourists decide to travel from point A to point B, there are several Apps they can leverage to make good choices. These Apps will combine services from several companies (airlines, hotels, taxis) and provide comparisons. It will show which airlines are cheaper or have shorter layovers or travel durations. They will know what type of aircraft will be used on their route; they can select their seats in the cabin and order their meals in advance. The Apps can also provide weather information and help the tourists decide on indoor or outdoor activities at their destination during their visit. If point A and point B are in different countries the Apps may also provide information on entry Visa requirements for the tourists. The concept of IoS revolves around the basic idea that systems should be able to locate useful resources online and utilise them for their application or benefit. For example, the oil company, Total, will be able to execute maintenance actions (or gain some maintenance decision support) in their new Martin Linge Field in Norway based on cloud based data service partly populated from their older Ofon Field in River Niger's delta area of Nigeria.

1.4 Internet of Things (IoT)

The traditional Internet today provides "connection" for over one billion people through platforms such as Facebook and Twitter. However, the era of advanced and cheap sensors coupled with the successful derivation of the Internet Protocol IPv6 in 2012 means that there are now enough IP addresses to assign to every device (sensor, actuator or any object) configured in a way as to be networked directly with the Internet (Industrie 4.0 Working Group, 2013). The

Internet of Things refers to a pervasive, perhaps ubiquitous, network society in which a lot of objects are "connected" (Yan, et al 2008). IoT in essence may be viewed as a subset of the CPS i.e. the cyber-physical systems (discussed in the next paragraph) though both terms may be used interchangeably by different authors often influenced by the region in which they work or carry out research. The concept of the smart factory to have a large network of small, decentralised intelligent embedded devices is driven by the IoT paradigm.

1.5 Cyber-Physical Systems (CPS)

Cyber-Physical Systems (CPS) are integrations of computation and physical processes (Lee & Wang, 2008). Today, several systems are embedded with autonomous chips which are wirelessly networked with one another and also able to access the Internet thereby providing a tight and definite link between the cyberspace and the physical world. Such seamless interactions define the notion of cyber-physical systems (CPS). The benefits of CPS are obvious. Imagine that you have a smart device built into your mobile phone that continuously monitors and records your blood pressure and is capable of not only being able to alert you in the event that measurements are out of range with respect to some predefined references but is also able to schedule an appoint for you with a doctor or even calling an ambulance in the event of an emergency; imagine also that this device is intelligent enough (maybe big data driven) to know that the sudden rise in your blood pressure was because you were being attacked by some unruly youngsters and also calls in the police; imagine as well that this device detects that you have not had enough sleep and resets your alarm clock two hours ahead and cancels your earliest appointments for the day. These are all realistic examples. Thus, systems or system of systems in a CPS scenario are able to communicate and control one another in a collaborative manner. The CPS has the novel advantage of being able to offer early warnings, mitigate surprises and is therefore well suited to predictive maintenance applications within the environments of the Industrial Internet.

1.6 The Three Dimensional Printing (3DP) Technology

The 3DP is an important technology for the implementation of Industry 4.0. It is shown in (Bak, 2003) and (Dimitrov, et al 2006) that the

original motivation for the 3DP was the need to generate design iterations or to create cheap metal parts directly from a Computer Aided Design (CAD) file. However, the state-of-the-art of the 3DP technology has clearly gone beyond a mere concept modelling or rapid prototyping tool into the realm of commercial manufacturing. There is an existing technology for making carbide parts which are used in diesel engines and aircraft parts manufacturing because of their high thermal and electrical conductivity. However, it is also worthy to comment that 3DP is far from proven technology. Further research to fine-tune the 3DP technology is currently being pursued but so also are research effort geared towards the maturity of the aforementioned Internet 4.0 enabling technologies highlighted and discussed in this section.

There is therefore a need to make a conscious effort to integrate Industry 4.0 compliant technologies in ways that would engender synergy leading to the creation of new and novel Industrial Internet services. Cloud computing and big data analytics, for example, are key enablers for the data driven predictive maintenance within Industry 4.0. Consequently, research and development (R & D) efforts in companies that understand the significance of these shifting paradigms are helping to drive innovation and create services such as machine-to-machine (M2M) sensor-based data for status monitoring and system prognosis. Combining the results of a data analysis with the system structure and online condition monitoring, the technique can be used as a basis to reduce inspection/maintenance required to sustain the reliability of critical systems. The ultimate end product of integrating these technologies and novel services is the evolutionary emergence of today's manufacturing floors into the smart factories of the future.

3. Smart Factories: A New Approach within Industry 4.0

The paradigm shift referred to as smart factories are the "end products" of the practical application of the continuing advances made in the areas of cyber-physical systems and modern ICT tools. It will constitute a key feature of Industry 4.0. Based on Mark Weiser's vision of ubiquitous computing (Lucke, et al 2008, and Zuehlke, 2010) it is convenient to identify the main components of the smart factory as calm-systems (or hardware) and the context-aware applications (software) using

networking logic and advanced computing to create a virtual duplicate of physical systems. The use of sensor data from physical processes to continually update the virtual representations in real-time means that the systems are robust, resistant to disturbances and may include self-healing processes that enable it to recover from failures and thereby showing the attribute of resilience. The applicable data is processed in cyberspace through some smart algorithms in such a format as to calculate and synchronise information about the equipment's performance, risks and health conditions in real-time (Lee, 2015). Smart factory is a vision for the factory of the future where both the manufactured products and the engineered production lines form part of an intelligent system that can talk to or control each other by means of machine-to-machine (M2M) communication or other intelligent algorithms. Consciously designed, easily replaceable modules deployed on a wireless network will enhance production processes and increase efficiency. In addition to achieving shorter product life cycles and more product variants, the smart factory environment offers improved performance, quality and availability.

Factories of the future (FoF) will be an environment populated with a large amounts of small intelligent devices interconnected and interacting in a collaborative way to create an overall smart system as opposed to the present but fast fading practice of concentrating a huge computing power inside a single frame of a computer system. Colombo & Karnouskos, 2009 argue that the approach whereby intelligence is shared amongst a large number of loosely coupled and decentralised intelligent devices makes it easier for a system to be both adaptable and reconfigurable to meet several demands of business which at the time of the system's design may not have been conceived. This unique feature means that the factories of the future are in tune with today's market trend where consumers are becoming the focus of the businesses and in doing so are driving the products design (Souza, et al 2006). The increased use of advanced technology in manufacturing means that products are made in a resource efficient manner and within a much shorter time from conception to the market. According to the report of the European Factories of the Future Research Association, 2013: *"The purpose of manufacturing is to create value while the factory may be defined as the place where society concentrates its repetitive value creation process."* The FoF envisions that a sustainable

way of creating value through manufacturing should encompass high performance production, a zero-defect tolerance with a high degree of both energy and resource efficiencies. To that extent, the FoF public private partnership (PPP) project has its specific objectives channelled towards research and innovation (R & I). The R & I efforts will harmonise different advances in the technological field for the benefit of advanced manufacturing. This includes the use of exoskeletons to safely interact and assist humans from the factory floor to the warehouse. The FoF cannot afford to underestimate the benefits of mechatronic systems and advanced robotics in manufacturing. The airframe manufacturer, Airbus has demonstrated the use of a robotics application named MiRA which is an acronym for the Mixed Reality Application (Álvarez, et al 2016). MiRA has now been deployed in commercial use on the company's A380 and A350 XWB aircraft types' production lines currently to help with inspections on secondary structural brackets. Such brackets are used in the aircraft to hold systems (e.g. hydraulic or oxygen systems) and the piping systems securely together. The A380 fuselage for example has up to eighty thousand (80,000) of such brackets with the unique demand that each must be checked/inspected before every aircraft's entry into service (the law of sampling does not apply). MiRA has reduced the inspection time for these brackets from 3 weeks to 3 days, providing savings in labour costs but at the same time helping with a quicker detection of missing brackets, as well as wrongly positioned or damaged ones.

Research into the use of humanoid robotics is an ongoing investigation but MiRA and similar applications are obvious demonstrations of benefits that can accrue from integrating robots as team members in manufacturing generally or maintenance in a narrower sense. Robots can lift heavy tools and equipment and help its human counterparts to work in a more effective manner, it can access difficult to access areas for example hot sections of industrial boilers or some designated "hell holes" in some small aircraft. By taking away boring routines from humans and lowering labour costs at the same time, this application synchronises with the specific objectives of the FoF to lead in researches to reverse the deindustrialisation of Europe, create social impact and promote entrepreneurship. However, whereas the manufacturing innovations as advocated in the FoF Roadmap 2020 has a primarily regional target its actual relevance has by all means and measures a global impact.

4. A Theoretical Conceptual Framework for Predictive Maintenance within Industry 4.0

When describing the theoretical concept of predictive maintenance it is important to clarify the terminology, behaviour and structure of predictive maintenance. According to the European Standard EN 13306, predictive maintenance is defined as (CEN, 2010): "*Condition based maintenance carried out following a forecast derived from repeated analysis or known characteristics and evaluation of the significant parameters of the degradation of the item.*" In that sense, a predictive maintenance concept can be realized by combining the dual objectives of fault diagnosis and prognosis of a system's future behavioural patterns. Whereas diagnosis deals with fault detection including its location and the possible causes of such deviations from predefined thresholds, fault prognosis follows the trajectory of the fault over time and estimates the end of life (EOL) or remaining useful life (RUL) of the component or system under consideration. In the current paper therefore, we use predictive maintenance in the sense that it also includes system prognosis. Prognostic techniques are broadly categorized into data-driven (when available data is used) or model-based (when system structure is the basis) (Marjanović, et al 2011). Although our proposed approach is a novel combination of both categories, we do not go into a detailed discussion of the various prognostic techniques, however we point out that in order to be able to make any logical prediction it must be possible to spot some patterns and to verify that these patterns are reasonably consistent both horizontally (from equipment to equipment on a sizeable fleet of similar machines) and vertically (from time to time and/or place to place). It might be challenging to define what a sizeable fleet means but to use a number, 40 or more would be reasonable. A fleet as used here refers to a collection of items of same or corresponding part numbers distinguished by their respective serial numbers. These equipment or subassemblies may have been made by the same or different manufacturers for the same or different owners or operators. The important point is that each of the equipment generates data into a common database. Therefore, the predictive maintenance concept will rely heavily on the utilised algorithm's ability to establish patterns from the processed sensor data in real-time. This pattern is then compared with stored patterns generated both from laboratory or model based data and historic data based on previous actual field experience.

Cloud based service platforms will be essential both for data storage and analysis. The result will give an indication of the equipment performance and proactively pinpoint maintenance needs where necessary. In (Lee, et al 2014) it is argued that embedded intelligence in industrial applications means that systems become more adaptive and increasingly compliant with technologies that can be used to predict an equipment's future, rank its performance, measure its health condition or degradation and autonomously or semi autonomously boost the equipment effectiveness. Applied within maintenance, the aim will be to identify critical issues through systematic diagnostics and data analytics. The maintenance manager will be able to act responsibly, knowledgeably and quickly in the events of any in-service faults or failures. Such early warning systems will be helpful in reducing down times, improving maintenance scheduling and spare parts provisioning. Rather than being a mere unorganised symptom data which is the state-of-the-art today, the data driven closed loop predictive maintenance system shown in Figure 2 is based on the idea that the generated data can be recorded, stored, structured and analysed for the purpose of fault identification and system prognosis.

The closed loop predictive maintenance concept developed involves different systems. The closed loop ensures that all the different systems function as a whole. It is further assumed that, in the long run, the aim of achieving a self-regulating system is met. The feedback system incorporates both leading indicators (e.g. mean time to failure (MTTF) and forward looking feedback signals) and lagging indicators (e.g. degradation indication feedback signal). The system structure can be derived partly from a Failure Mode, Effects and Criticality (FMECA) procedure with the block also providing a possibility for integrating an automatic Reliability Centred Maintenance (RCM) or CMMS.

Each part of the feedback loop has the capability to record and store its own history in a queryable database. An error or deviation signal is generated during evaluation by comparing feedback signal to the input signal and degradation model. By way of illustration, we consider our smart machine to be some sort of a "smart room" with an infant sleeping in it; if the deviation signal is "temperature too low" the compensator could be a heater which then comes on to warm up the room. This is based on the concepts of CPS and IoT described earlier. The controlled variable in this example is therefore the

room temperature. The adjusted room temperature as a result of the compensation action is fed back for further evaluation to either continue to keep the heater running or to shut it down pending when it receives another demand to operate. This is an iterative process that ensures that resources and energy are utilised efficiently, with minimised costs, improved workplace safety and increased equipment availability. In the course of the iteration, what the predictive analytics tool on the return leg of the feedback loop does is to take into account, for example, how long it took the room temperature to normalise after the initial demand or how often the demands come; it then probes the big data to find

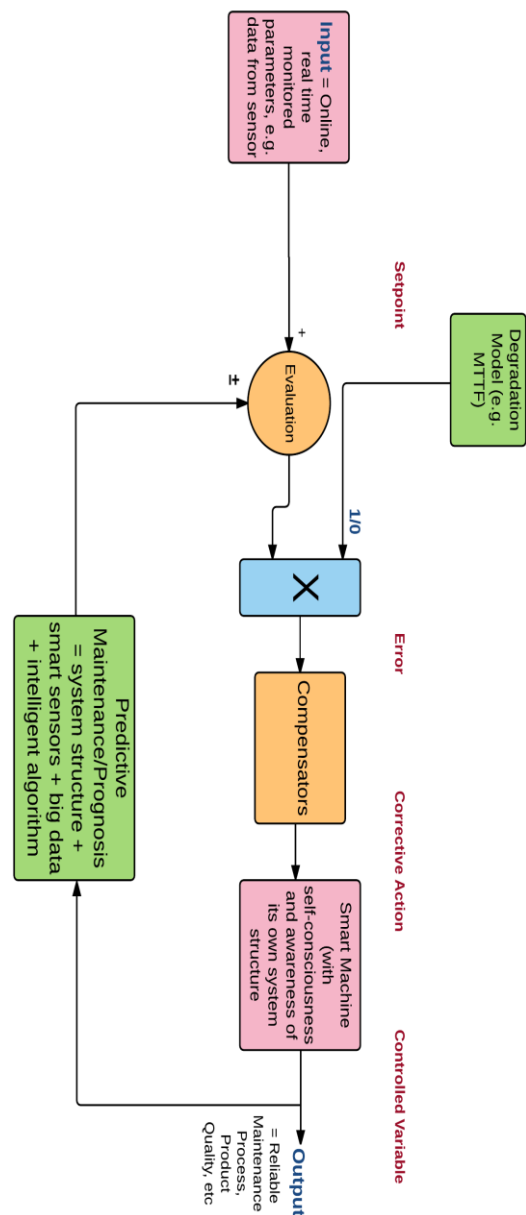

Figure 2: Model Feedback Predictive Maintenance and System Prognosis Loop

out what is "normal" based on previous experience (pattern recognition), pass it through the intelligent algorithm which then gives an indication of system performance level or an indication of a degraded state and raise a flag to call for a maintenance action if necessary. The closed loop maintenance concept is therefore an on-demand, data-driven maintenance technique that ensures that maintenance is carried out only as required and based on actual field data. This novel system will build upon advances made in the area of machine learning and machine-to-machine interaction. The current practice within maintenance is to record faults or failures and the actions taken to rectify these snags on some dedicated log books. The CMMS, Computerized Maintenance Management System, can provide an additional capability of presenting these records in an electronic and searchable form. In addition, some sectors are well organised in their approach, for example the aviation industry uses the Airlines Transport Association ATA chapters which helps aircraft engineers to group events in accordance with predefined systems. But these are all open systems that do not provide communication back to the equipment to close the loop. We hope that every maintenance event provides a learning opportunity not only for the machines in question but also for the organisation in general. Therefore, we propose that some representative information from the process output should be fed back into the machine to facilitate this learning or modify the machine's software or other attributes in some ways. The representative output may be the final product quality or other measurable parameters such as voltage regularity and temperature for example which are digitized and fed back through the machine in either qualitative or quantitative format depending on the system configuration, complexity and need.

5. Towards Asset Maintenance Needs of the Future: Expectations and Results

Industry 4.0 will revolutionise manufacturing and increase productivity. It will lead to the creation of new business models and present a basis for new and novel services. A typical example of such services which are already beginning to emerge in the industry is the application of distributed cloud systems in asset maintenance. The current paper assesses the effect of the integration of some Industry 4.0 key enabling technologies, intelligent

devices, pervasive computing and of course classical physics, as a result, a closed loop data driven predictive maintenance system is developed. The major contribution of this feedback system is that the loop is closed at the machine-to-machine level rather than just at an organisational level which is today's industry state-of-the-art. The data driven closed loop predictive maintenance system developed can be credited with some important results which we have summarised as follows:

- An increased automation in maintenance will benefit from machine generated data as in Industry 4.0 most machines have extensive capabilities for self-diagnosis but most times the results of such diagnosis are used as mere representations of symptoms and do not help in any way for predicting or giving an indication of future failures. The reason being that, in such open loop systems, the effect of a diagnosis that has revealed a fault state is that the snag is simply cleared and forgotten. In contrast, the closed loop feedback loop for predictive maintenance developed here, remembers each fault or failure event and uses it in the future not only for the same machine but also for all similar machines linked to its network via the distributed cloud globally or through a small company's intranet locally, depending on its functional configuration. The developed predictive maintenance feedback loop integrates well into the framework of the European Union's Factories of the Future projects and proposals briefly highlighted in section 3.
- Maintenance task execution often introduces some consequential hazards through human error or wrong operational or organisational procedures. Developing a system such as the feedback predictive maintenance system that helps to reduce maintenance needs has an instant effect on improving the safety performance not only of the production equipment but also that of the workplace as well.
- The systems developed in this project leverage on Industry 4.0 key enabling technologies such as the distributed cloud system, big data mining and analysis, Internet of Things, Cyber-Physical Systems, three dimensional printing technology, and other innovative technologies and intelligent devices to deliver solutions which are not only more

efficient and effective but also have positive cost benefits. For example, the cost benefit to a Nigerian oil and gas company which has an operational base in Norway will be enormous based on travel and logistic costs alone if an Industry 4.0 cloud based asset maintenance system is implemented across the value chain of the company and thereby limiting the need to travel.

As companies continue to focus on novel and efficient ways of doing business, there will be an ever increasing appetite for novel technologies such as the data driven closed loop predictive maintenance system proposed in this paper. The proposed maintenance structure can only succeed if it is undertaken as a multi-disciplinary project, collaborative effort is required in disparate fields from robotics engineering to computer science all the way down to sociology and psychology. The system hinges on several innovations most of which are far from being proven technologies. Further research is therefore required in the following areas:

- Integration effort to harmonise mechatronic systems and computer programming to suit the Industry 4.0 production factory
- There should be a clearly defined road-map for the implementation of Industry 4.0 that meets the needs of different industry sectors. This can be achieved through publicly available published guidelines and standards
- Development of industry-grade software and smart algorithms that would meet demands of Industry 4.0 companies
- Address the needs of standardisation, interoperability, open systems applications, and adaptability
- Adapting today's production floor to suit the smart factory specifications is an urgent research challenge that must be tackled
- Integration of predictive maintenance capabilities from an early design phase in future products and in future production lines. Industry 4.0 implementation pays attention to both products and production equipment because the product of one company could be the production equipment of another company.
- By design, robustness and resilience of products and production assets must address issues of cyber security, activities of criminal hackers and unethical

competitors. Advanced encryption techniques should be investigated and comprehensive risk assessment must be carried out to establish the links between individual risks and the possible consequences.

6. Conclusions

The basic structures proposed in this paper set out general frameworks for a data driven closed loop feedback predictive maintenance system for implementation within an Industry 4.0 environment. It is sufficient to conclude based on the results expected from the developed system that its integration with the system structures and degradation models of the aggregating components or assemblies has the potential to reduce maintenance frequency on critical assets or increase the interval of offline inspections, increase safety around production equipment in the workplace, increase asset availability and boost both productivity and profitability. The ultimate end products will be reliable, robust and resilient systems that offer asset operators the best life cycle benefits.

7. Acknowledgements

The lead author became motivated to write this paper while working as a research assistant in the summer of 2015 at the Production and Quality Engineering Department of the Norwegian University of Science and Technology, NTNU under an umbrella of funding provided through the European Union's Green Monitor Project. We are profoundly grateful to the NTNU, the EU Green Monitor Project and our families.

8. References

1. Álvaro, F., Favila, R., & Hugo, A. (2016). Factory of the future – New ways of manufacturing. Airbus Group. <http://www.airbusgroup.com/int/en/story-overview/factory-of-the-future.html> .
2. Bai, H., Ma, Z., & Zhu, Y. (2012). The application of cloud computing in smart grid status monitoring. In *Internet of Things* (pp. 460-465). Springer Berlin Heidelberg.
3. Bak, D. (2003). Rapid prototyping or rapid production? 3D printing processes move industry towards the latter. *Assembly Automation*, 23(4), 340-345.
4. CEN 2010. NS-EN 13306: Maintenance Terminology Standard.
5. Colombo, A. W., & Karnouskos, S. (2009). Towards the factory of the future: A service-oriented cross-layer infrastructure. *ICT Shaping the World: A Scientific View. European Telecommunications Standards Institute (ETSI), John Wiley and Sons*, 65, 81.
6. Dimitrov, D., Schreve, K., & De Beer, N. (2006). Advances in three dimensional printing-state of the art and future perspectives. *Rapid Prototyping Journal*, 12(3), 136-147.
7. European Factories of the Future Research Association. (2013). Multi Annual Roadmap for the Contractual PPP under Horizon 2020.
8. Evans, P. C., & Annunziata, M. (2012). Industrial internet: Pushing the boundaries of minds and machines. *General Electric. November*, 26.
9. Industrie 4.0 Working Group. (2013). Recommendations for implementing the strategic initiative INDUSTRIE 4.0. *Final report, April*.
10. Lee, J. (2015). Smart Factory Systems. *Informatik-Spektrum*, (pp. 1-6). Springer.
11. Lee, J., & Wang, H. (2008). New technologies for maintenance. In *Complex System Maintenance Handbook* (pp. 49-78). Springer London.
12. Lee, J., Kao, H. A., & Yang, S. (2014). Service innovation and smart analytics for industry 4.0 and big data environment. *Procedia CIRP*, 16, 3-8.
13. Lucke, D., Constantinescu, C., & Westkämper, E. (2008). Smart factory-a step towards the next generation of manufacturing. In *Manufacturing systems and technologies for the new frontier* (pp. 115-118). Springer London.
14. Manyika, J., Chui, M., Brown, B., Bughin, J., Dobbs, R., Roxburgh, C., & Byers, A. H. (2011). Big data: The next frontier for innovation, competition, and productivity.
15. Marjanović, A., Kvaščev, G., Tadić, P., & Đurović, Ž. (2011). Applications of predictive maintenance techniques in industrial systems. *Serbian Journal of Electrical Engineering*, 8(3), 263-279.
16. Mell, P., & Grance, T. (2011). The NIST definition of cloud computing.
17. Schroth, C., & Janner, T. (2007). Web 2.0 and SOA: Converging concepts enabling the internet of services. *IT professional*, 9(3), 36-41.
18. Souza, M. C. F., Sacco, M., & Porto, A. J. V. (2006). Virtual manufacturing as a way for the factory of the future. *Journal of Intelligent Manufacturing*, 17(6), 725-735.
19. Stuber, A. & Ferreira, L. (2016). Smart maintenance – A novel platform for maintenance management within asset management.
20. Thielke, S., Harniss, M., Thompson, H., Patel, S., Demiris, G., & Johnson, K. (2012). Maslow's hierarchy of human needs and the adoption of health-related technologies for older adults. *Ageing international*, 37(4), 470-488.
21. Yan, L., Zhang, Y., Yang, L. T., & Ning, H. (Eds.). (2008). *The Internet of things: from RFID to the next-generation pervasive networked systems*. CRC Press.
22. Zuehlke, D. (2010). SmartFactory — Towards a factory-of-things. *Annual Reviews in Control*, 34(1), 129-138.

Intentionally left blank

Paper TWO

Condition Monitoring for Predictive Maintenance – Towards Systems Prognosis within the Industrial Internet of Things

Douglas O. Chukwuekwe¹, Tommy Glesnes², Per Schjøberg¹

¹Department of Production and Quality Engineering, The Norwegian University of Science and Technology (NTNU), S.P. Andersen veg 5, 7491 Trondheim, Norway

² Karsten Moholt AS, Storebotn 90, 5309 Kleppstoe, Askoy, Bergen, Norway

Email: douglasco@engineer.com; tommy.glesnes@karsten-moholt.no; per.schjolberg@ntnu.no

Abstract Vibration based condition monitoring (VBCM) is a well-established technique for the application of predictive maintenance to the rotating machinery. The use of this technique for the purpose of machine diagnosis is well researched but there is so far no proven technique for using the same vibration data for systems prognosis. This paper proposes an approach that uses a linear regression technique to derive a mathematical model which is in turn used to predict the future vibration severity of a rotating machine. The frequency peaks of the velocity spectra were used in a real plant case study where the VBCM was applied to the roller element bearing component of a drillship's thruster system. The results obtained were dramatically better than when the overall root-mean-square values of the time waveform were trended over the same period.

Key words Big data, Condition monitoring, IIoT, Industry 4.0, Predictive Maintenance, Prognosis.

1.0 Introduction

As organizations strive to reach their production targets there are assets that are critical to their operations. The reliability and availability of these critical assets directly impact the profit margins of the organizations and by implication their continued existence. Within an organization's maintenance function, predictive maintenance techniques such as condition monitoring and prognosis have today gained an increased attention because they are important to balance the dilemma between maintenance costs and technical acceptability. The level of competence and success recorded with the vibration based condition monitoring techniques means

that they have found useful applications within varied industries from aerospace to manufacturing as well as the oil and gas industry in recent times.

However, as the transition is made away from traditional manufacturing and standalone systems, a major concern expressed within the industry is that the current approach presented within Industry 4.0 (the Industrial Internet of Things (IIoT)) [7] for implementing predictive maintenance places too much emphasis on low level data monitoring to a degree that compromises the level of competence already achieved within the industrial application of vibration based condition monitoring and there is so far no proven method to overcome the challenge.

The ultimate goal of any condition monitoring system is to gain the capability to predict the future of the equipment monitored [2]. Such a goal would be hard to reach by simply monitoring low level data such as temperature and pressure as currently suggested in the literatures related to Industry 4.0 although there are still not many publications available in this area. The IIoT is a new and evolving paradigm, therefore research and implementation are still in their formative stages. Previous publications are quick to highlight the strategic importance of big data but fail to demonstrate how it can be organized and analyzed for the purpose of predictive maintenance and for completing the maintenance decision loop. From the perspective of maintenance, the obvious weakness in the present big data exists in the fact that they are collected mainly for operational reasons and only serves maintenance purposes often “accidentally” or as an afterthought at the best.

In this paper, investigations have been carried out and the results reported can bridge some of the existing gaps. Using vibration monitoring of rotating equipment as a case study, it was demonstrated that the next generation of condition monitoring can integrate well into the Industrial Internet beyond low level data monitoring which is currently the case. It was shown that the application of a systematically selected stochastic process to low level data provides the required scaling up of vibration data to produce a more realistic and more practicable solution compared with any existing technique for the implementation of predictive maintenance within the Industry 4.0 environment. Machine generated real data and an industry grade software were deployed to obtain results which are not only compatible with the proposed Industry 4.0 reference architecture but also show a higher level of service when utilizing the proposed condition monitoring technique. Using modern sensors and instrumentation techniques, vibration data is collected in a structured manner for the main purpose of predictive maintenance. The collected data is dimensioned and treated in a form compatible with Industry 4.0 requirement for single value data while retaining the original properties of vibration data. It was proposed to capture multiple snapshots of vibration patterns to which a single average value is assigned to the frequency spikes for every successive and corresponding time horizon. These

values are aggregated over time and a regression is run adopting the technique of the autoregressive moving average (ARMA) to predict future failures. This is essentially a machine learning model that follows the propagation of an existing degradation over time and then estimates a future time when the degradation is beyond a predefined threshold. This gives room for planning and arranging for logistics in advance to minimize or totally avoid downtime.

Hence this new approach is expected to radically redefine the use of vibration based condition monitoring techniques within the Industrial Internet of Things without any loss of fidelity in its application to predictive maintenance and thereby ensuring safe cost reduction and the optimal utilization of asset value. It is expected that the proposed solutions are refined further through collaborative efforts of researchers and the end-users in the industry to reach a regulatory level of acceptability.

2.0 Rotating Machines Prognostics: The Science & Art of Vibration Technique

Vibration is characterized with frequency (measured in Hertz, CPM or RPM) and amplitude (measured either as peak, peak-to-peak or RMS values). The vibration energy can be described in terms of either the displacement (measured in micrometers), velocity (measured in millimeters per second) or acceleration (measured in meters per square second) caused by its transmission. A vibration signal can be related to another vibration or reference signal in terms of phase. There are several international standards dedicated to best practices in vibration analysis. They are mostly focused on the area of using vibration analysis for the purpose of operational monitoring and acceptance testing of rotating equipment or reciprocating machines. They often generally cover diagnosis but there is so far neither an existing standard nor is there available any proven technique to use vibration analysis to implement system prognosis. This is important because gaining an early awareness about an impending failure provides the opportunity to mitigate surprises and plan maintenance based on a schedule to optimize production time and reduce downtime. This section proposes a technique that provides a basis for using vibration analysis to carry out system prognosis within the framework of a predictive maintenance policy. The discussion begins with an introduction to ISO 10816-1 standard to aid a better understanding of the topic.

2.1 Mechanical Vibration and the ISO 10816

The ISO 10816 is one of the key international standards that set out the procedures and conditions for measurement and evaluation of vibration data. The ISO 10816 specifically focuses on measurements made on non-rotating/nonreciprocating parts of the machine. It stipulates two evaluation criteria. These are the magnitude of vibration and the change of vibration. The vibration signal captured from a machine is specified to be broadband in the sense that the frequency spectrum of the equipment under consideration is reasonably covered. The appropriate frequency range for any given type of machine will depend on its configuration and the previous experience gained with its vibratory behavior.

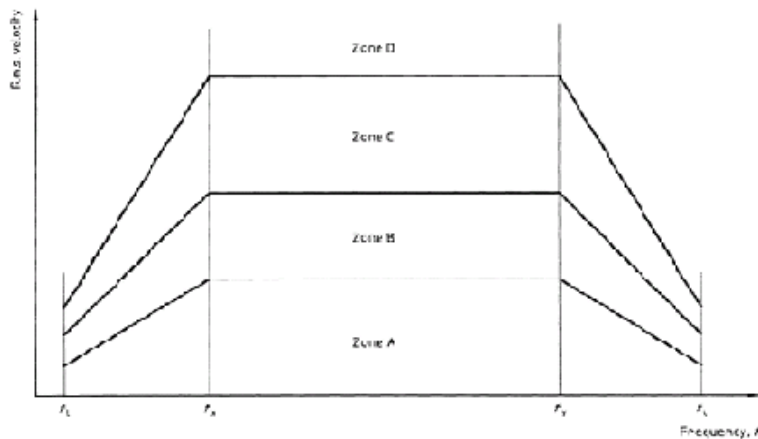

Figure 2.1: ISO 10816 – General form of vibration velocity acceptance criteria

The overarching objective of any vibration analysis system is to determine the vibration severity of a machine and the trend of the vibration over time, increasing or decreasing. In order to meet this objective, measurements are made at carefully selected measurement points and often in two or three different directions which are mutually perpendicular to each other. This results in a set of vibration data representing vibration magnitude. By definition, vibration severity is the “*maximum broadband magnitude value measured under agreed machine support and operating conditions*” (ISO 10816-1). In many machines a single vibration severity value is enough to characterize the vibration level however in other cases it will be insufficient and a more accurate representation will depend on a number of severity values from several locations. The vibration severity at each bearing housing or pedestal is compared with the four predetermined evaluation zones (Zones A, B, C and D) stipulated by the ISO 10816-1 and ISO 10816-3 standards to give the indication of normalcy, alarm or trip (ref. Figure 2.1). The measuring positions are marked and subsequent measurements are taken from the same positions with the same transducer orientations and similar operating conditions, otherwise it may produce an erroneous result when trended over time. When these conditions are met, significant

changes from the established normal vibration readings must be investigated further to avoid reaching a position which could be dangerous to the continued operation of the machine. It is however important to note that in some cases some deviations cannot be detected unless the frequency components of the vibration signal is analyzed. This is further illustrated with the use of a case study in the following section.

2.2 Case Study: Implementing System Prognosis with the Thruster Gearbox Bearing Velocity Spectra

The vibration data used in this case study were obtained from measurements made on a roller element bearing at one of Company A's machines. The velocity spectrum for a component of the thruster system, that is one of the gearbox bearings was analyzed. The survey periods are assumed to be at six months interval. That is a logical deduction but it was not exactly the case. It is important to assume an equal interval to proceed with the regression analysis. The results of the regression analysis is shown on Figure 2.2. The numbers used for the regression were obtained by taking the average of 5 peaks on a survey period: the maximum peak for the period, two next lower peaks on the left and two next lower peaks on the right. The frequency range of interest was from 250 Hz to 300 Hz (this frequency range is associated with the bearing of interest). The vibration severity or peaks are measured in millimeters per second.

Survey Period	Peaks: Y,X		Survey Period	Peaks: Y,X	
1	0.65		2	2.29	0.65
2	2.29	0.65	3	2.55	2.29
3	2.55	2.29	4	2.34	2.55
4	2.34	2.55	5	2.42	2.34
5	2.42	2.34	6	2.84	2.42
6	2.84	2.42	7	3.86	2.84
7	3.86	2.84	8	4.86	3.86
8	4.86	3.86	Model Prediction for: 9	4.96	

ANOVA					
	df	SS	MS	F	Significance F
Regression	1	3.4336	3.4336	7.575866	0.040194
Residual	5	2.266143	0.453229		
Total	6	5.699743			

	Coefficients	Standard Error	t Stat	P-value	Lower 95%	Upper 95%	Lower 95.0%	Upper 95.0%
Intercept	1.096117	0.744827	1.471639	0.201092	-0.81852	3.010756	-0.81852	3.010756
X	0.795704	0.289092	2.752429	0.040194	0.05257	1.538838	0.05257	1.538838

Figure 2.2: First Order Linear Regression of Vibration Severity/Peaks

From the regression analysis, the model for predicting the next period's expected vibration severity was derived as $1.096117 + 0.795704 Y_t$ (where Y_t is the vibration severity of the most recent survey period.) The model predicted the vibration severity for period 9 to be 4.96 millimeters per second. Having a systematic way to carry out such predictions has many benefits. In the current case study, surveys were repeated at six months interval. At the end of each survey, it is possible to predict what we expect the vibration severity to be six months from the most recent survey campaign. Should the predicted vibration severity be significantly higher than the predetermined acceptable levels, the asset managers have the benefit of initiating the plan to carry out maintenance long before the possible failure of the component. While working in partnership with the industry for this paper it was observed that maintenance engineering service providers may have reason to authorize the continued use of an equipment even when a trend that could lead to failure has been observed. The main reason for not carrying out maintenance as soon as the first sign of possible failure is known was found to be predicated upon considerations for production interruption. In such situations where it was necessary to escalate the maintenance requirements, the engineering company was observed to have offered the equipment utilization extension based on "expert judgement and best guesses or honest estimates." The systematic approach proposed in this paper offers a more scientific and objective technique for reaching such decisions. Another question that is necessary to address is what the appropriate survey interval should be. This is a difficult question as it will generally involve commercial and contractual considerations. The accessibility of the equipment or its known reliability performance and the cost to personnel or in extreme cases interruption to production flow are among important factors to consider before the survey interval is selected. Due to random events, it might sometimes be necessary to embark on vibration data collection at a time that is off the agreed interval. In such cases, the asset managers have to document and implement the additional survey campaigns without distorting the planned survey periods.

2.2.1 The model has the following limitations:

- Only a few data points (7 observations) were used to train the model.
- The recorded readings were made at different machine revolutions. It was only after July 3rd 2013 that measurements were made consistently at 680 RPM. Between December 12, 2011 and February 01, 2013 the range of RPM where vibration readings were taken varied from 583 to 710. This is contrary to the recommendations made in [4], [5], [6] and certainly has an influence on the derived model.
- Frequency peaks were measured without linking them with their corresponding phase angles. Treating frequency as a vector quantity rather than as a scalar produces better results as shown in the standards referenced in the above bullet point.

- The interval between the survey periods were not equal. In some cases it was approximately six months but it was not generally true.
- The regression analysis has been carried out using the data analysis function in Microsoft Excel. It was sufficient to demonstrate the result but a commercial application would require a more advanced software perhaps application tailored computing.

In order to overcome the aforementioned limitations, the pursuit of predictive maintenance and prognostic techniques need be a rigorously implemented policy. Lots of data are now being generated within industrial applications [3], [7] and with the continued improvements in sensor technology, data mining will witness an upward trend [8], [9]. It is necessary to look into the generated data, structure and analyze it to help in maintenance decision support as well as other value added services. Data scientists will play an increasingly important role in the future of maintenance practice. Analyzing a sufficient amount of data from the same or similar machines with some statistical techniques such as the lifetime models which have been rigorously treated in standard statistical literatures will improve asset reliability and availability. The application of the Nelson-Aalen estimator and the Kaplan-Meier estimator techniques, for example, to the relevant data sets can aid better understanding of components' failure trajectories and a more accurate estimation of the machine's mean time to failure (MTTF) or other important system structures and parameters. The big data is important but the systematic analysis of the big data provides the value adding perspective that would help organizations to realize their overarching business functions to maximize stakeholders' value.

3.0 Smart Maintenance: The Discussion Continues

Condition monitoring is intended to measure the current status of an operational item but it does not automatically imply that a predictive maintenance policy is in place [2]. There has to be a system that receives the parameter values measured by the condition monitoring technique and utilise these values as an input to the predictive maintenance strategy. A condition monitoring programme is an irreducible minimum for the predictive maintenance strategy to hold but a successful predictive maintenance concept is a consciously applied policy. The evolving paradigms of the Industrial Internet of Things (IIoT) gives credence to the prediction of the 4th industrial revolution which was first identified in Germany as Industry 4.0. The disruptive nature of an industrial revolution means that there will be a shift in the general ways of doing things and there has been discussions in the maintenance engineering communities as per the impacts of these shifts in practice. The relevance of this paper and the results obtained from the investigations are grounded in the reach to provide some basic proposals on how to structure and analyse vibration data for the purpose of predictive maintenance and systems prognosis. It is expected to be a means to bridge the state-of-the-art in maintenance

and the future maintenance practice which is smart by its perspective and data driven by application. It was established that the frequency spectrum correctly captures the vibration energy in the rotating machinery when subjected to vibration analysis. The use of frequency peaks in spectral analysis for trending provided better results than conventional trended overall values. Spectral analysis provides a means to separate a complex vibration time waveform into its component frequency spectra which in turn offer the benefit to identify and isolate specific frequencies resulting from each and every component in a complex rotating machine. This was traditionally used for troubleshooting and diagnosis. The investigations conducted for this paper revealed that these frequency peaks can also be used to predict the future behavioural patterns of the rotating machinery and estimate its future vibration severity based on ordinary linear regression.

The particular data-set used for the case study came from a roller bearing which formed part of a thruster assembly on a drill ship. The relevant data used for the regression analysis had a span of eight periods. The interval between two successive periods was approximately six months. When a first order linear regression analysis was conducted based on the data from the eight periods (that is only 8 observations), a prediction model was established. From the regression analysis, the model for predicting the next period's expected vibration severity was derived as $1.096117 + 0.795704 Y_t$ (where Y_t is the vibration severity of the most recent survey period.) The model predicted the vibration severity for period 9 as 4.96 millimetres per second. If this mathematical model is validated to hold true in similar operating conditions it becomes easy to write an algorithm that is capable of implementing system prognosis. The derived model has the limitation that it was based only on 8 observations which is grossly insufficient. The framework nonetheless provides a basis for further investigations as more data become available. With only a few data points, it was only reasonable to run a linear regression. However, in another report [1] it was suggested that the quadratic model offered better results than linear ones. This report lacked sufficient data to either confirm or refute the claim that quadratic models are better than linear models. The strength of this investigation is that it has provided a proposal which can be easily adapted to create models which can be used for predictive maintenance and prognosis as the sensor technology continues to revolutionise condition monitoring whilst also driving both the big data and big data analytics for the smart maintenance applications.

The rotating machinery form an integral part of most production assets. Pumps, compressors, electrical motors and generators, separators, and gas turbines are common examples of rotating machinery used in industries. The use of vibration analysis for purposes of condition monitoring and diagnostics has been very successful within standalone systems in conventional applications. However, the concept of smart maintenance based on Industry 4.0 requires an extensive use of data [7]. The challenge is to present the data in a format that is compatible with the design philosophies and the reference architecture for the Industrial Internet of Things (IIoT) [3]. This report has provided an initial proposal for tackling the stated challenge. It further shows a technique that makes use of structured data to

implement systems prognosis based on the frequency spectrum of vibration data. The procedure outlined for implementing predictive maintenance was simple but a limited amount of data was used. That limitation makes it difficult to argue that the results obtained would be valid in all circumstances. The next phase of improvement must utilise a more extensive data coverage that would help determine the degree of accuracy of the results of the prognosis. In addition to expanding the data coverage, there is a need to calculate and provide the confidence intervals associated with every prediction. The gradual progression from condition monitoring to condition based maintenance and predictive maintenance up to prescriptive maintenance is both worthy and realisable within the sphere of smart maintenance. In order for the idea to reach a proven technology and a regulatory level of service there has to be a consciously targeted effort by all sectors to improve the techniques for measuring parameters and running the analysis. A further refinement of the ideas proposed in this paper to a point of commercial viability is recommended along with the inclusion of those partner companies who are willing to set up pilot services to validate the proposed ideas.

4.0 Conclusion

The derived mathematical model for predicting the future vibration severity was based on single values which are compliant with the proposed Industry 4.0 reference architecture. The vibration data stored, processed and analyzed in the compliant format helps to populate the big data which in turn is used for the data driven smart maintenance which has a great descriptive accuracy, predictive powers and prescriptive capabilities. Condition monitoring was shown to be a safe cost cutting mechanism to the benefit of operators and asset managers because it provides a mechanism to avoid or mitigate surprises. Having an advance awareness about the degraded state of a production asset offers the valuable advantage of synchronizing maintenance needs and operational demands.

References

- [1] Chudnovsky, B.H., Livshitz, A. and Chudnovsky, B.A., 2008, October. Thermal model of electrical contacts based on experimental data. In 2008 Proceedings of the 54th IEEE Holm Conference on Electrical Contacts (pp. 205-211). IEEE.
- [2] Chukwuekwe, D.O., Schjølberg, P., Rødseth H. and Stuber A., 2016. Reliable, Robust and Resilient Systems: Towards Development of a Predictive Maintenance Concept within the Industry 4.0 Environment. EFNMS Euro Maintenance Conference 2016, May 30 – June 2. Athens, Greece.
- [3] Evans, P.C. and Annunziata, M., 2012. Industrial internet: Pushing the boundaries of minds and machines. General Electric. November, 26.
- [4] ISO 10816-1: Mechanical vibration—Evaluation of machine vibration by measurements on non-rotating parts—Part 1: General guidelines. ISO Switzerland, 1995.
- [5] ISO 10816-3: Mechanical vibration—Evaluation of machine vibration by measurements on non-rotating parts—Part 3: Industrial machines with nominal power above 15 kW and nominal speeds between 120 r/min and 15,000 r/min when measured in situ. ISO Switzerland, 2009.
- [6] ISO 7919-1: Mechanical Vibration of non-reciprocating machines - Measurements on rotating shafts and evaluation criteria—Part 1: General guidelines. ISO Switzerland, 1996.
- [7] Industrie 4.0 Working Group, 2013. Recommendations for implementing the strategic initiative INDUSTRIE 4.0. Final report, April.
- [8] Lee, J., Kao, H.A. and Yang, S., 2014. Service innovation and smart analytics for industry 4.0 and big data environment. *Procedia CIRP*, 16, pp.3-8.
- [9] Manyika, J., Chui, M., Brown, B., Bughin, J., Dobbs, R., Roxburgh, C. and Byers, A.H., 2011. Big data: The next frontier for innovation, competition, and productivity.

Authors' Biography

	<p>Douglas O. Chukwuekwe</p> <p>Engr. Douglas O. Chukwuekwe is an aircraft and project engineer with over ten years of experience. He worked as a Teaching and Research Assistant at the Norwegian University of Science & Technology, Trondheim while taking the MSc in Reliability, Availability, Maintainability and Safety (RAMS) Engineering, a programme from which he recently graduated. He is a motivated and budding researcher with interests in novel condition monitoring techniques, predictive maintenance and reliability by design. He was a speaker at the European Federation of National Maintenance Societies' (EFNMS) 24th Biennial Euro Maintenance Conference, 2016 in Athens, Greece.</p>
	<p>Tommy Glesnes</p> <p>Engr. Tommy Glesnes is the Chief Technical Officer (CTO) of Karsten Moholt AS, a leading technology provider with specialties in electro-mechanical machinery, motors and generators. An approved vibration training instructor and a Category III vibration analyst with over 25 years of practice, he is certified by the EFNMS as a European Expert in Maintenance Management.</p>
	<p>Per Schjølberg</p> <p>Dr Per Schjølberg is an Associate Professor and the former Head of the Production and Quality Engineering Department at the Norwegian University of Science and Technology, NTNU-Trondheim. He sits on the Board of several organisations.</p>

Intentionally left blank

". . . it is not
enough to be up
to date you have
to be up to
tomorrow."

David Ben Gurion, 1st Prime Minister of
Modern Israel

