



**NTNU – Trondheim**  
Norwegian University of  
Science and Technology

# Horizontal well length optimization considering wellbore hydraulics

**Adnan Syed**

Petroleum Engineering

Submission date: June 2014

Supervisor: Jon Kleppe, IPT

Norwegian University of Science and Technology  
Department of Petroleum Engineering and Applied Geophysics



**HORIZONTAL WELL LENGTH OPTIMIZATION**  
**CONSIDERING WELL BORE HYDRAULICS**

By: Adnan, Syed

A Thesis submitted in partial fulfillment of  
the requirements for the degree of

Master of Science in  
Petroleum Engineering

At



(Submitted: June 2014)

## **ACKNOWLEDGEMENT**

I would like to express my extreme gratitude to Prof. Jon Kleppe who has provided his utmost guidance and support to me throughout my master project. He has delivered his valuable suggestions throughout completion of this research work. Without his supervision and keen interest, this thesis would not have been possible.

I also would like to thank Assistant Prof. Jan Ivar Jensen who has helped me understanding Eclipse Software.

In addition, a thank you to Adviser Lisbeth Hultmann for her supports, a thank you to senior Engineers Lars Johan Sandvik and Erlend Våtevik for their help in technical issues.

I will also remain grateful to NTNU University who has provided a very peaceful environment for studies and research.

## **ABSTRACT**

Horizontal wells covering entire length of the reservoirs are not economically suitable. Frictional pressure drops increase with the increase in well length and flow rates. Optimal horizontal length is estimated through economic analysis i.e. Net present Value of the project (NPV). Well construction costs including incremental costs of drilling horizontal section, friction losses in horizontal section, Hydrocarbon prices and Drainage area affect NPV.

This thesis work estimates NPV and Productivity Indices of horizontal well projects with the use of simulation results under operating conditions of drawdown limits and constant bottom hole flowing pressures using Finite conductivity concept. Horizontal wells assuming frictionless wellbores are also discussed.

The results of NPV and PI are used to estimate the optimal length of horizontal wellbore in this work.

Relatively shorter well lengths were found to be more economical than the lengthier ones in every case. Well bore flow rates of 1600 stb/day in the case of well bore roughness variation didn't decrease productivity to high extent. Higher flow rates such as a minimum of 2600 stb/day were reported to be involved in decreasing productivity for well lengths of 3000-4000 ft. for diameter of 2.5 inches.

Well length optimization through objective functions based on NPV, flow rates and bottom hole flowing pressures are possible future works.

## TABLE OF CONTENTS

S.NO		Page
1.	INTRODUCTION	1
2.	PREVIOUS WORK ON HORIZONTAL WELL PRESSURE DROPS, LENGTH OPTIMIZATION AND ECONOMIC ANALYSIS	2
2.1	Steady state pressure profile of Horizontal wells (Undamaged Horizontal well)	2
2.2	Formation Anisotropy	3
2.3	Damaged Horizontal well	3
2.4	Frictional Flow in the Horizontal well bore	4
2.5	Determination of Wellbore Hydraulic Effects by Anklam and Wiggins	5
2.6	Friction Factor and Reynolds number	7
2.7	Productivity Index	8
2.8	Optimization of Well length	9
2.9	Economic Evaluation by Hyun Cho, SPE, Kellogg Brown & Root Inc.	9
2.9.1	Well Construction Cost	10
2.9.2	Results by Hyun Cho, SPE, Kellogg Brown & Root Inc.	13
2.9.3	Optimum Well Length	14
2.9.4	Comparison of Results with Novy Method	16
3.	THESIS WORK	17
3.1	Data File	17
3.2	Simulation Software	17
3.3	Model Description	18
3.4	Control Data for Production Wells	19
3.4.1	Case-1: Well bore Hydraulic Effects (Constant Bottom hole Flowing Pressures)	19
3.4.2	Case-2: Well bore Hydraulic Effects (Drawdown Limits)	19
3.4.3	Case-3: Infinite Conductivity (Drawdown Limits)	19
3.4.4	Case-4: Well bore Hydraulic Effects (Wellbore roughness)	20
3.4.5	Case-5: Well bore Hydraulic Effects (Wellbore diameter)	20
3.4.6	Case-6: Well bore Hydraulic Effects (Injection Well Support)	21
3.7	Black Oil and Relative Permeability data	22
3.7.1	Fluid Property Data	22
3.7.2	Relative Perm. and Capillary Pressure	22

<b>S.NO</b>		<b>Page</b>
3.8	Reservoir Data	23
	3.8.1 Grid Block Dimensions in x-direction	23
	3.8.3 Grid Block Dimensions in y-direction	23
	3.8.3 Grid Block Dimensions in z-direction	24
3.9	Well location/Completion data	24
3.10	Densities, Viscosities and Compressibility Data	25
3.11	Well Specification Data	25
3.12	3-D Model Appearance	26
3.13	Calculation of productivity index	29
3.14	NPV Calculations	30
	3.14.1 For Single Well	30
	3.14.2 Drainage Area for Single Horizontal Well	32
	3.14.3 NPV for more than 1 well	33
3.15	Plotting of Graphs	34
4.	SIMULATION RESULTS	35
4.1	Case-1 (a)	35
4.2	Case-1 (b)	36
4.3	Case-1 (c)	37
4.4	Case-2 (a)	38
4.5	Case-2 (b)	39
4.6	Case-2 (v)	40
4.7	Case-3 (a)	41
4.8	Case-3 (b)	42
4.9	Case-3 (c)	43
4.10	Case-4 (a)	44
4.11	Case-4 (b)	45
4.12	Case-4 (c)	46
4.13	Case-5 (a)	47
4.14	Case-5 (b)	48
4.15	Case-5 (c)	49
4.16	Case-6 (a)	50
4.17	Case-6 (b)	50
4.18	Case-6 (c)	50
5.	DISCUSSION OF RESULTS	51
5.1	Case-1 (a), Case-1 (b) and Case-1 (c)	51
5.2	Case-2 (a), Case-2 (b) and Case-2 (c)	51
5.3	Case-3 (a), Case-3 (b) and Case-3 (c)	52
5.4	Case-4 (a), Case-4 (b) and Case-4 (c)	53
5.5	Case-5 (a), Case-5 (b) and Case-5 (c)	53
5.6	Case-6 (a), Case-6 (b) and Case-6 (c)	54
6.	SIMULATOR LIMITATIONS	55
6.1	Discussion on Allowable Drawdown Limit	55
6.2	Discussion on Average Reservoir Pressure	56

<b>S.NO</b>		<b>Page</b>
7.	SOURCES OF ERRORS	57
	7.1 Well Costs	57
	7.2 Well bore pressure drops	57
	7.3 Steady state or transient Productivity Index	58
8.	CONCLUSION	59
9.	RECOMMENDATION/FUTURE WORK	60
10.	REFERENCES	61
11.	APPENDIX	64



## List of Figures

Fig.NO.		Page
2.1	Schematic of Horizontal well Drainage Area	2
2.2	Comparison of Productivity Index v/s well length	7
2.3	Schematic of Horizontal well showing constant wellbore pressure and infinite conductivity produced by Novy [9]	8
2.4	Vertical depth and Drilling Cost	18
2.5	Effects of Horizontal well length and drawdown pressures on productivity index <b>[1]</b> (4-1/2-in wellbore, $k_v = 1$ md, $k_h = 10$ md)	13
2.6	Effects of wellbore diameters on prod. rate <b>[1]</b> (150 psi drawdown pressure , $k_v = 1$ md & $k_h = 10$ md)	14
2.7	Effects of wellbore roughness on prod. rate <b>[1]</b> (4-1/2- in wellbore, 150 psi drawdown pressure, $k_v = 1$ md, $k_h = 10$ md)	14
2.8	NPV Revenue and Total Cost <b>[1]</b>	15
2.9	NPV of the project with optimum horizontal well length v/s single well construction cost [1]	16
2.10	Productivity rate v/s horizontal well length calculated with the Novy Method	16
3.1(a)	Initial Pressure distribution of the simulation model for Cases-1 to 5	26
3.1(b)	Initial Pressure distribution of the simulation model for Case-6	26
3.2(a)	100 ft. well length	27
3.2(b)	450 ft. well length	27
3.2(c)	2250 ft. well length	27
3.2(d)	5400 ft. well length	28
3.2(e)	7200 ft. well length	28

<b>Fig.NO.</b>		<b>Page</b>
3.3	Drainage areas for Horizontal well presented by Joshi [2]	32
4.1	NPV and Total Cost v/s Horizontal Well Length for Case-1(a)	35
4.2	NPV project and Single Well Construction Cost v/s Horizontal Well Length for Case-1(a)	35
4.3	Productivity Index v/s Horizontal Well Length for Case-1(a)	35
4.4	NPV and Total Cost v/s Horizontal Well Length for Case-1(b)	36
4.5	NPV project and Single Well Construction Cost v/s Horizontal Well Length for Case-1(b)	36
4.6	Productivity Index v/s Horizontal Well Length for Case-1(b)	36
4.7	NPV and Total Cost v/s Horizontal Well Length for Case-1(c)	37
4.8	NPV project and Single Well Construction Cost v/s Horizontal Well Length for Case-1(c)	37
4.9	Productivity Index v/s Horizontal Well Length for Case-1(c)	37
4.10	NPV and Total Cost v/s Horizontal Well Length for Case-2(a)	38
4.11	NPV project and Single Well Construction Cost v/s Horizontal Well Length for Case-2(a)	38
4.12	Productivity Index v/s Horizontal Well Length for Case-2(a)	38
4.13	NPV and Total Cost v/s Horizontal Well Length for Case-2(b)	39
4.14	NPV project and Single Well Construction Cost v/s Horizontal Well Length for Case-2(b)	39
4.15	Productivity Index v/s Horizontal Well Length for Case-2(b)	39

<b>Fig.NO.</b>		<b>Page</b>
4.16	NPV and Total Cost v/s Horizontal Well Length for Case-2(c)	40
4.17	NPV project and Single Well Construction Cost v/s Horizontal Well Length for Case-2(c)	40
4.18	Productivity Index v/s Horizontal Well Length for Case-2(c)	40
4.19	NPV and Total Cost v/s Horizontal Well Length for Case-3(a)	41
4.20	NPV project and Single Well Construction Cost v/s Horizontal Well Length for Case-3(a)	41
4.21	Productivity Index v/s Horizontal Well Length for Case-3(a)	41
4.22	NPV and Total Cost v/s Horizontal Well Length for Case-3(b)	42
4.23	NPV project and Single Well Construction Cost v/s Horizontal Well Length for Case-3(b)	42
4.24	Productivity Index v/s Horizontal Well Length for Case-3(b)	42
4.25	NPV and Total Cost v/s Horizontal Well Length for Case-3(c)	43
4.26	NPV project and Single Well Construction Cost v/s Horizontal Well Length for Case-3(c)	43
4.27	Productivity Index v/s Horizontal Well Length for Case-3(c)	43
4.28	NPV and Total Cost v/s Horizontal Well Length for Case-4(a)	44
4.29	NPV project and Single Well Construction Cost v/s Horizontal Well Length for Case-4(a)	44
4.30	Productivity Index v/s Horizontal Well Length for Case-4(a)	44
4.31	NPV and Total Cost v/s Horizontal Well Length for Case-4(b)	45

<b>Fig.NO.</b>		<b>Page</b>
4.32	NPV project and Single Well Construction Cost v/s Horizontal Well Length for Case-4(b)	45
4.33	Productivity Index v/s Horizontal Well Length for Case-4(b)	45
4.34	NPV and Total Cost v/s Horizontal Well Length for Case-4(c)	46
4.35	NPV project and Single Well Construction Cost v/s Horizontal Well Length for Case-4(c)	46
4.36	Productivity Index v/s Horizontal Well Length for Case-4(c)	46
4.37	NPV and Total Cost v/s Horizontal Well Length for Case-5(a)	47
4.38	NPV project and Single Well Construction Cost v/s Horizontal Well Length for Case-5(a)	47
4.39	Productivity Index v/s Horizontal Well Length for Case-5(a)	47
4.40	NPV and Total Cost v/s Horizontal Well Length for Case-5(b)	48
4.41	NPV project and Single Well Construction Cost v/s Horizontal Well Length for Case-5(b)	48
4.42	Productivity Index v/s Horizontal Well Length for Case-5(b)	48
4.43	NPV and Total Cost v/s Horizontal Well Length for Case-5(c)	49
4.44	NPV project and Single Well Construction Cost v/s Horizontal Well Length for Case-5(c)	49
4.45	Productivity Index v/s Horizontal Well Length for Case-5(c)	49
4.46	Productivity Index v/s Horizontal Well Length for Case-6(a)	50
4.47	Productivity Index v/s Horizontal Well Length for Case-6(b)	50

**Fig.NO.**

**Page**

4.48      Productivity Index v/s Horizontal Well Length  
for Case-6(c)

50

## **List of Tables**

<b>S.NO.</b>		<b>Page</b>
3.1	Control data for Case-1	19
3.2	Control data for Case-2	19
3.3	Control data for Case-4	20
3.4	Control data for Case-5	20
3.5	Control data for Case-6	21
3.6	Fluid Property Data for simulation data file	22
3.7	Relative Permeability Data for simulation data file	22
3.8	y-Direction grid block sizes in simulation input	23
3.9	z-Direction grid block sizes in simulation input	24
3.10	Well Location/Completion Data in simulation input	24
3.11	Densities, Viscosities and compressibility Data in simulation input	25
3.12	Well Specification data in simulation input	25
3.13	Summary Keyword used in Data file	29

## **NOMENCLATURE**

$p_e$  = external boundary pressure, psi [F/L<sup>2</sup>]

$p_F$  = immediate arbitrary pressure in wellbore, psi [F/L<sup>2</sup>]

$p_h$  = pressure at heel of wellbore with friction loss, psi [F/L<sup>2</sup>]

$p_h'$  = pressure at the heel of wellbore without friction loss, psi [F/L<sup>2</sup>]

$\Delta p_f$  = friction pressure loss [F/L<sup>2</sup>]

$Q'$  = Oil Production rate without Friction loss, stb/d [L<sup>3</sup>/T]

$\mu$  = fluid viscosity, cp [M/Lt]

$B_o$  = Oil Formation Volume Factor, bbl/stb

$K_H$  = Horizontal permeability, md [L<sup>2</sup>]

$h$  = formation thickness, ft [L]

$X$  = Drainage Configuration parameter, dimensionless

$L$  = horizontal well length, ft [L]

$r_w$  = radius of well, ft [L]

$\rho$  = fluid density, [M/L<sup>3</sup>]

$\mu$  = dynamic viscosity [M/Lt]

$v$  = fluid mean velocity [L/T]

$D$  = Characteristic length (Hydraulic diameter of pipe) [L]

$f$  = fanning friction factor

$N_{RE}$ ,  $Re$  = Reynolds number

$J_s$  = Specific PI, [L<sup>3</sup>/T]

$p_i$  = pressure at constant pressure boundary, [F/L<sup>2</sup>]

$(d/d_x) q_w(x)$  = change in well rate

$q_e$  = influx into horizontal well per unit length [L<sup>2</sup>/T]

$(d/d_x) p_w$  = pressure gradient inside the well

$R_w$  = flow resistance caused by turbulence

$V_{in}$  = influx velocity, ft/s [L/T]

$r_w$  = wellbore radius, ft [L]

$v$  = velocity, ft/s [L/T]

$x$  = length of horizontal section, ft [L]

$K$  = influx loss coefficient

$V$  = fluid velocity in horizontal section [L/T]

$V_{in}$  = influx velocity, ft/s [L/T]

$dp/dx$  = pressure gradient

$D$  = pipe diameter, ft [L]

$\varepsilon$  = absolute tubing roughness having same units as  $D$ .

$\frac{dp_w}{dx}$  = wellbore pressure drop [F/L<sup>2</sup>]

$g_c$  = conversion factor

$\$Cost_v$  = Cost of Vertical section per foot , \$

$D_{tv}$  = Depth of Vertical Section, ft [L]

$\$Cost_H$  = Cost of Horizontal section, \$

$A$  = Estimated unit construction cost for horizontal wells

$L$  = Horizontal well length, ft [L]

$B$  = Coefficient as the fixed cost

$n$  = Construction Cost Exponent

$DR$  = Discount rate (%)

$t$  = producing life of well [T]

$k$  = year

$R$  = Gross Revenue, \$

$Q^k$  = Yearly Production

$\$_{oil}^k$  = average oil price of the year

$N$  = number of wells

$q$  = unit flow rate [L<sup>3</sup>/T]

$D_k$  = Production decline rate



$C_o$  = operating cost in dollars per year

$C_h$  = Overhead cost in dollars per per

$C_c$  = Construction cost in dollars per unit length

$C_p$  = Capital Cost of the project in dollars per year

$C_t$  = Taxes in dollars per year

FOPR = Field Oil Production Rate, stb/day [ $L^3/T$ ]

FWPR = Field Water Production Rate, stb/day [ $L^3/T$ ]

FGPR = Field Gas Production Rate, Mscf/day [ $L^3/T$ ]

FLPR = Field Liquid Production Rate, stb/day [ $L^3/T$ ]

FOPT = Field Oil Production Total, stb [ $L^3$ ]

FWPT = Field Water Production Total, stb [ $L^3$ ]

FGPT = Field Gas Production Total, Mscf [ $L^3$ ]

FLPT = Field Liquid Production Total, stb [ $L^3$ ]

FWCT = Field Water Cut Total [ $L^3$ ]

FGOR = Field Gas Oil Ratio, Mscf/stb

FOE = Field Oil Efficiency

FPR = Field Pressure average Value, psia [ $F/L^2$ ]

WBHP = Well Bottom hole pressure, psia [ $F/L^2$ ]

CPR = Connection pressure, psia [ $F/L^2$ ]

CPR<sub>at toe</sub> = Connection pressure at toe of horizontal section, psia [ $F/L^2$ ]

CPR<sub>at heel</sub> = Connection pressure at heel of horizontal section, psia [ $F/L^2$ ]

$\alpha$  = an empirical correlation parameter

$\bar{p}$  = Average reservoir pressure at drainage radius, psia [ $F/L^2$ ]

$P_{wf}$  = flowing bottom hole pressure, psia [ $F/L^2$ ]

$r_{ev}$ : 745 ft (effective vertical well radius for 40 acre well spacing)

$Q_{max}$  = maximum flow rate at each timestep

$D_{max}$  = maximum allowable drawdown at each time step

$T_{wj}$  = well connection transmissibility factor

$M$  = Mobility of selected phase

$P_{av}$  = average reservoir pressure, psia

$P_w$  = well flowing pressure, psia

$P_{w,min}$  = minimum well flowing pressure, psia

$H_{wj}$  = Hydrostatic wellbore pressure head between the connection  $j$  and well's bottom hole pressure reference depth.

### **SUBSCRIPTS**

$x, y$  = horizontal axes

$z$  = vertical axis

$h$  = horizontal



## 1. INTRODUCTION

Pressure drops in the horizontal section of the wellbore varies with the approach used in the calculations or simulations. Infinite conductivity or constant wellbore pressure neglects the drops in horizontal conduits and exaggerates the amounts of pressures or flow rates at the heel of the horizontal wells.

This thesis work is the continuation or the extension of the work carried out by the author in the previous semester project

In reality, frictional effects play its role on productivity and these give rise to Finite conductivity concept. This means that the continued increase in horizontal well lengths with the expectation of increased in Net present value of the project is not a realistic one.

This thesis report has discussed the work of the authors who have studied methods for optimization of horizontal wells.

Further, with the help of simulation results, this thesis work estimates NPV and Productivity Indices (PI) of following projects:

1. Wells operating on Pressure control mode considering wellbore hydraulics
2. Drawdown limits on production wells using finite conductivity concept
3. Drawdown limits on production wells assuming constant well bore pressure
4. Variations in Wellbore roughness and tubing diameters using finite conductivity concept

PI of the case when Pressure supplements to production well through injection well is also discussed.

As Economical analysis estimating Net present Values of horizontal well projects is an excellent tool in order to make decisions of the favorable project, therefore the discussions on choosing the appropriate cases are made in the end.

Designing Objective functions based on optimization of NPV, flow rates and bottom hole flowing pressures are possible future work.

**2. PREVIOUS WORK ON HORIZONTAL WELL PRESSURE DROPS, LENGTH OPTIMIZATION AND ECONOMIC ANALYSIS**

In this section, historical work done in the past on the above topic by several authors is discussed.

**2.1 Steady state pressure profile of Horizontal wells (Undamaged Horizontal well)**

Giger [3] and Joshi [2] analyzed 3D steady state flow to Horizontal wells in 2D flow that caused separation of the flow area in two zones inside the ellipsoidal drainage area. The solutions for ellipsoidal drainage (fig 2.1) area being effective for smaller horizontal well lengths only, Giger [3] took this concept to rectangular drainage area (fig 2.1) for larger well lengths.

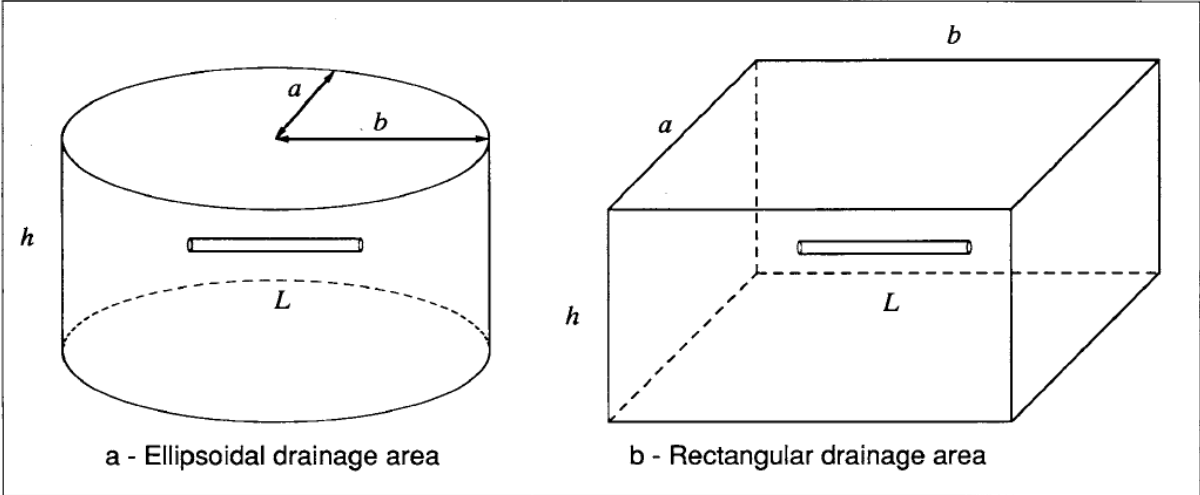

*Figure2.1 - Horizontal well Drainage areas*

To break 3D to two 2D problem zones, 1<sup>st</sup> of these two zones were the nearby well section in which flow is in vertical planes perpendicular to well axis. Flow in 2<sup>nd</sup> zone was studied further from the well bore in horizontal planes. Summation of pressure drop in two sections provided composite wellbore pressure drops as:

$$\frac{p_e - p_h}{3D - xyz} = \frac{p_e - p_F}{2D - xy} + \frac{p_F - p'_h}{2D - yz} + \frac{\Delta p f}{2D - xy} \text{ ----- Eq.1}$$

In the zone (2D-xy), [4], [3] gave pressure drop as:

$$p_e - p_F = \frac{Q' \mu B_o}{2\pi K_H h} \text{Cosh}^{-1}(X) \text{-----Eq.2(a)}$$

In the zone (2D-yz), [3] formulated pressure drop as:

$$p_F - p'_h = \frac{Q' \mu B_o}{2\pi K_H L} \ln\left(\frac{h}{2\pi r_w}\right) \text{-----Eq.2(b)}$$

Adding Eq. 2(a) and Eq. 2(b), composite pressure drop was calculated:

$$p_e - p'_h = \frac{Q' \mu B_o}{2\pi K_H h} \left[ \text{Cosh}^{-1}(X) + \frac{h}{L} \ln\left(\frac{h}{2\pi r_w}\right) \right] \text{-----Eq.3}$$

## 2.2 Formation Anisotropy

Muscat [5] brought vertical anisotropy concept  $\beta = \sqrt{(K_H/K_V)}$  and applied it to 2 dimensional vertical flow pressure drops in horizontal wells. With its application, well became elliptical and need and axes distance needed to be multiplied by  $\sqrt{K_{eq}/K_H}$  and  $\sqrt{K_{eq}/K_V}$ , where  $K_{eq} = \sqrt{K_H K_V}$ . Radius of the well changed from  $r_w$  to  $r'_w$ , so Eq.3 transformed to:

$$p_e - p'_h = \frac{Q' \mu B_o}{2\pi K_H h} \left[ \text{Cosh}^{-1}(X) + \beta \frac{h}{L} \ln\left(\frac{h}{2\pi r'_w}\right) \right] \text{-----Eq.4}$$

Where :

$$r'_w = (1+\beta) / 2\sqrt{\beta}$$

## 2.3 Damaged Horizontal well

Skin effects the near well bore flow and caused either addition or reduction in the pressure drop in the wellbore vicinity due to development of Modified radius ( $r_s$ ). Joshi [2], Renard and Dupuy [6] introduced skin factor (s) for calculation of pressure drops near the well and came up with this equation:

$$p_e - p'_h = p_e - p(r_s) + p(r_s) - p'_h \text{-----Eq.5}$$

After substitution of pressures, above equation changes to:

$$p_e - p'_h = \frac{Q' \mu B_o}{2\pi K_H h} \left[ \frac{\pi a}{2L} + \frac{h}{L} \ln \left( \frac{h}{2\pi r_s} \right) \right] + \frac{Q' \mu B_o}{2\pi k_s L} \left[ -\ln \left( \frac{h}{2\pi r_s} \right) + \ln \left( \frac{h}{2\pi r_w} \right) \right]$$

By introducing  $S_H$  (Horizontal skin) in the equation:

$$p_e - p'_h = \frac{Q' \mu B_o}{2\pi K_H h} \left[ \frac{\pi a}{2L} + \frac{h}{L} \ln \left( \frac{h}{2\pi r_w} \right) + S_H \right]$$

Where;

$$S_H = \frac{h}{L} \left( \frac{k}{k_s} - 1 \right) \ln \left( \frac{r_s}{r_w} \right) = \frac{h}{L} S_v \text{ -----Eq.6}$$

To account for anisotropy, Eq.3 transforms to

$$p_e - p'_h = \frac{Q' \mu B_o}{2\pi K_H h} \left[ \text{Cosh}^{-1}(X) + \beta \frac{h}{L} \ln \left( \frac{2\beta}{1+\beta} \frac{h}{2\pi r_w} \right) + \beta \frac{h}{L} S_v \right]$$

Using effective wellbore radius concept;

$$p_e - p'_h = \frac{Q' \mu B_o}{2\pi K_H h} \left[ \text{Cosh}^{-1}(X) + \beta \frac{h}{L} \ln \left( \frac{h}{2\pi r'_{we}} \right) \right] \text{ -----Eq.7}$$

Where;

$$r'_{we} = \left[ \frac{1+\beta}{2\beta} \right] r_w \exp(-S_v)$$

## 2.4 Frictional flow in the horizontal well bore

Dikken [7] stated that flow in horizontal well usually observes the increase in mean velocity downstream the wellbore i.e. Horizontal well observes turbulent flow. He pointed out that turbulent flows happen when flow rates are the magnitudes of thousands of cubic feet per day and those give rise to higher Reynolds Number values. Reynolds number is defined as the ratio of inertial forces to viscous forces. Mathematically:

$$N_{Re} = \frac{\rho v D}{\mu} \text{ -----Eq.8}$$

If flow turns from Laminar to Turbulent, the latter causes quite higher pressure drops in horizontal well bore.

Dikken presented his model by dividing the reservoir into vertical cross sections and gave three equations to connect well and reservoir.

$$q_e(x) = J_s [p_i - p_w(x)] \quad \text{-----Eq. 9}$$

$$\left(\frac{d}{dx}\right) q_w(x) = -q_e(x) \quad \text{-----Eq. 10}$$

$$\left(\frac{d}{dx}\right) p_w(x) = R_w q_w(x)^{2-\alpha} \quad \text{-----Eq. 11}$$

By solving above three equations, he came up with the following equation;

$$\left(\frac{d^2}{dx^2}\right) q_w(x) = J_s R_w q_w(x)^{2-\alpha} \quad \text{-----Eq. 12}$$

$\alpha$  = an empirical correlation parameter between friction factor (f) and  $N_{Re}$ . It ranged from 0-0.25 where 0 corresponded to rough inner surface and 0.25 corresponded to smooth surfaces.

Dikken, using boundary conditions, suggested the following solution for flow rate while solving his 1<sup>st</sup> and 4<sup>th</sup> equations.

$$Q_{x=0} = \frac{2J_s(x)\Delta pL}{\exp[L\sqrt{J_s(x)R_s}]} \quad \text{-----E q. 13}$$

Dikken expressed that pressure drops caused by turbulent flow reduced drawdown appreciably at locations further from the toe of horizontal well and increasing well length would level off the total production.

## 2.5 Determination of Wellbore Hydraulic Effects by Anklam and Wiggins

Anklam and Wiggins [8] presented a new way of performance determination of horizontal well using wellbore hydraulics. Their model incorporated the effects of gravity, acceleration, gravity and fluid influx. Using Continuity Equation for steady state flow of incompressible liquid, they produced the following equation:



$$V_{in} = \frac{r_w dV}{2 dx} \text{-----Eq.14}$$

They also introduced following energy equation:

$$\frac{dp}{dx} = -\rho V \frac{dV}{dx} - \rho g \sin\theta - \frac{f \rho \bar{V}^2}{2D} - \frac{k\rho V_{in}^2}{2} \text{-----Eq.15}$$

Terms on right hand side of the Eq.9 represented acceleration, gravity, friction and influx losses respectively. They used the friction factor without any revision as the revised factors was used by Yaun [9] and Asheim [10] for better predictions.

Incorporating Darcy's law in their model, they used:

$$q_{res} = -\frac{k dp}{\mu dr} \text{-----Eq.16}$$

They solved Eq. 10 for single phase, incompressible, steady state laminar flow and rewrote as Eq.9. This solution took the following form:

$$\frac{dp}{dx} = -\frac{2\rho V J_s}{r_w A_m} (\bar{p} - p) - \rho g \sin\theta - \frac{f \rho \bar{V}^2}{2D} - \frac{k\rho}{2} \left(\frac{J_s}{A_m}\right)^2 (\bar{p} - p)^2 \text{-----Eq.17}$$

These systems of Equations were solved numerically using a Runge-Kutta fourth order method. The data set was taken from Brekke [11]. To avoid gas coning, the maximum draw down was limited to 15-20 psi. They used Novy [12] charts in order to see if well bore hydraulics would play its part or not. When compared Novy graph with data set, it was found out that well bore hydraulics would have its effect on productivity. Anklam and Wiggins found out that by increasing well length, productivity index first reached a maximum value and then it started decreasing and ultimately reached to zero. For the particular data set [11], well length that yielded maximum productivity index was found to be approximately 1000 ft (fig 2.2)

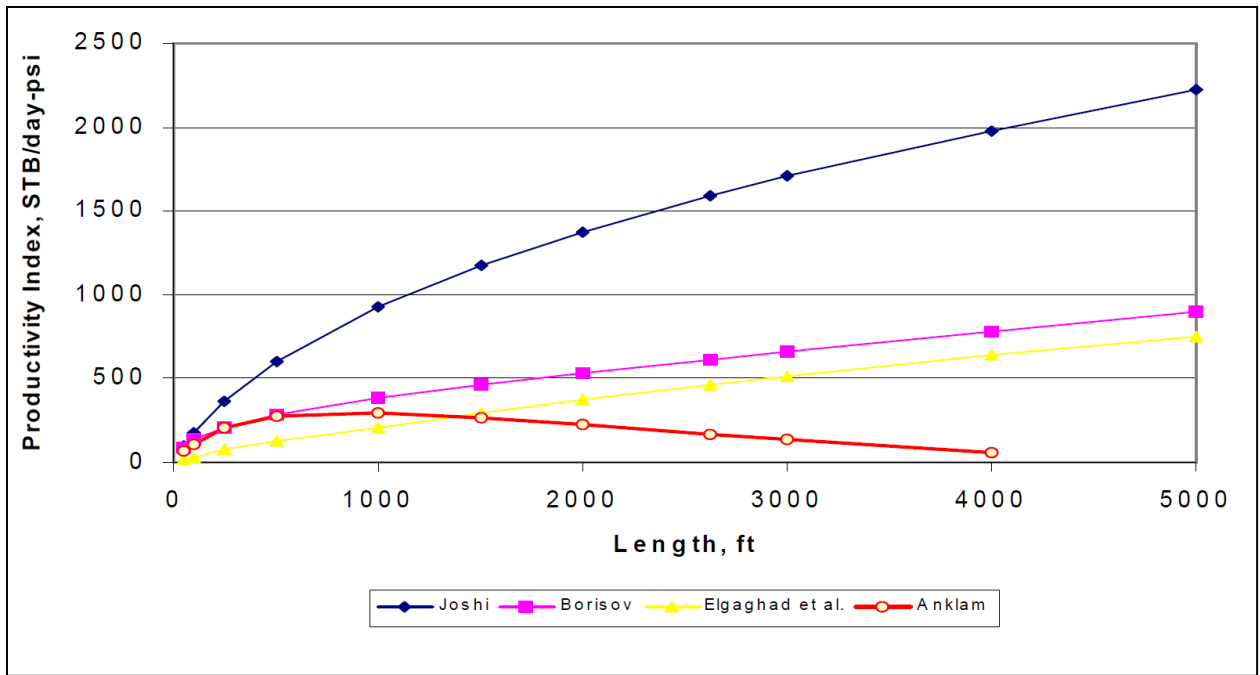

Figure 2.2 Comparison of Productivity Index v/s Well length

## 2.6 Friction Factor and Reynolds number

The friction factor is a function of Reynolds number and effective roughness of pipe.

For Laminar flow, friction factor is obtained through:

$$f = \frac{16}{N_{Re}} \quad \text{-----Eq. 18}$$

For turbulent flow, following friction factor correlations were put forward by Dikken [7], Haaland [13], Seins [14] and Jain [15]:

$$f = 0.079 N_{Re}^{-0.25} \quad \text{-----Eq. 19(a)}$$

$$\sqrt{\frac{1}{f}} = -3.6 \log_{10} \left( \frac{6.9}{N_{Re}} + \left( \frac{\epsilon}{3.7D} \right)^{10/9} \right) \quad \text{-----Eq. 19(b)}$$

$$f = 0.25 \left[ 1.8 * \log \left\{ \frac{6.9}{N_{Re}} + \left( \frac{\epsilon}{3.7D} \right)^{10/9} \right\} \right]^{-2} \quad \text{-----Eq. 19(c)}$$

$$f = 0.25 \left[ 1.14 - 2 \log \left( \frac{\epsilon}{D} + 21.25 N_{Re}^{-0.9} \right) \right]^{-2} \quad \text{-----Eq. 19(d)}$$

Well Bore pressure drop as a function of fanning friction factor is expressed as:

$$\frac{dp_w}{dx} = \frac{2f\rho V_x^2}{g_c D} \text{ -----Eq.20}$$

**2.7 Productivity Index**

Productivity Index, PI (J) is defined as the ratio of flow rate to the drawdown. This ratio can be measured either in steady state, transient or pseudo steady state but pseudo steady state gives a realistic estimate of PI. For Horizontal wells, this conventional PI is not suitable if well lengths exceeding approx. 3000 ft. because it neglects pressure drops from toe horizontal well to its heel.

Specific Productivity Index,  $J_s$  (Flow rate to drawdown in the toe to heel wellbore section) is the one used for Horizontal wells case (Fig 2.3). Following equation calculates Specific PI.

$$PI (J_s) = \frac{q}{p_e - p_F + p_F - p_{h'} + \Delta p_f} \text{ -----Eq.21}$$

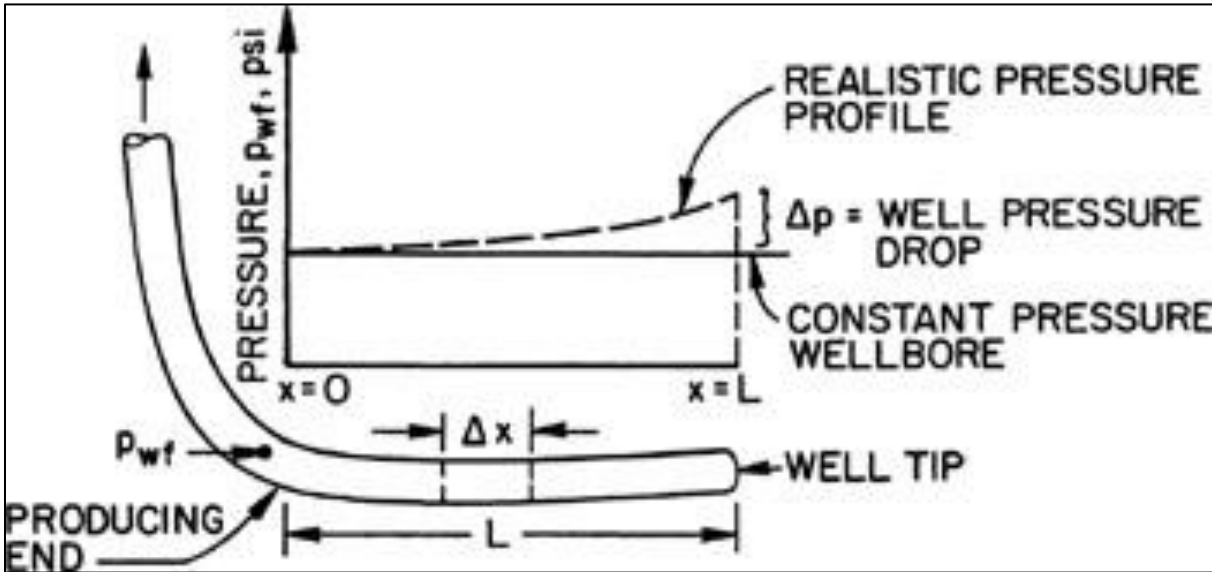

Figure 2.3- Schematic of Horizontal well showing constant wellbore pressure and infinite conductivity produced by Novy [9]

## **2.8 Optimization of well length**

Drainage area for the horizontal well increases as more lengthy conduits or the wells are drilled in the reservoir. With the advancements in the drilling engineering, horizontal wells up to the length of several thousands of feet such as up to 10,000 ft can be drilled. As frictional effects continue to increase with the increase in the well length [16], and wells after a certain threshold length are not economical one, therefore, optimization of horizontal well length is necessary in order to minimize the role of frictional effects.

According to studies, success rates of horizontal wells can be different in different reservoirs. 54% of the surveyed horizontal wells were found to be economically successful [17]. One important factor in determining the economics are the incremental expenses that incur over the drilling of horizontal wells over vertical drilling. This incremental cost can reach up to 1.4 to 3 times the cost of vertical drilling [2] [18] [19].

Other studies showed the statistics of horizontal wells length covering the full or partial length of the reservoir. It stated that 62 wells over the sampling of 91 wells were drilled up to whole length of reservoir [20].

## **2.9 Economic Evaluation by Hyun Cho, SPE, Kellogg Brown & Root Inc.**

It was suggested that important factors that determine economic analysis are [1]:

- Revenue increase
- Drainage area
- Hydrocarbon price
- Friction loss
- Productivity Index
- Early time production increase
- Well Construction Costs
- Reserves increase

**2.9.1 Well Construction Cost**

There were several costs associated with the total cost of drilling either Horizontal or vertical drilling. Those were divided into [1]:

- Construction Cost
- Capital Cost
- Operating Costs
- Company Overhead
- Taxes

Construction cost was calculated separately for vertical and horizontal sections. Vertical construction cost data was selected from the details of the historical wells drilled in different parts of world [21]. This data was integrated to produce a graphical form of Relationship b/w cost and vertical section as shown in the figure 2.4.

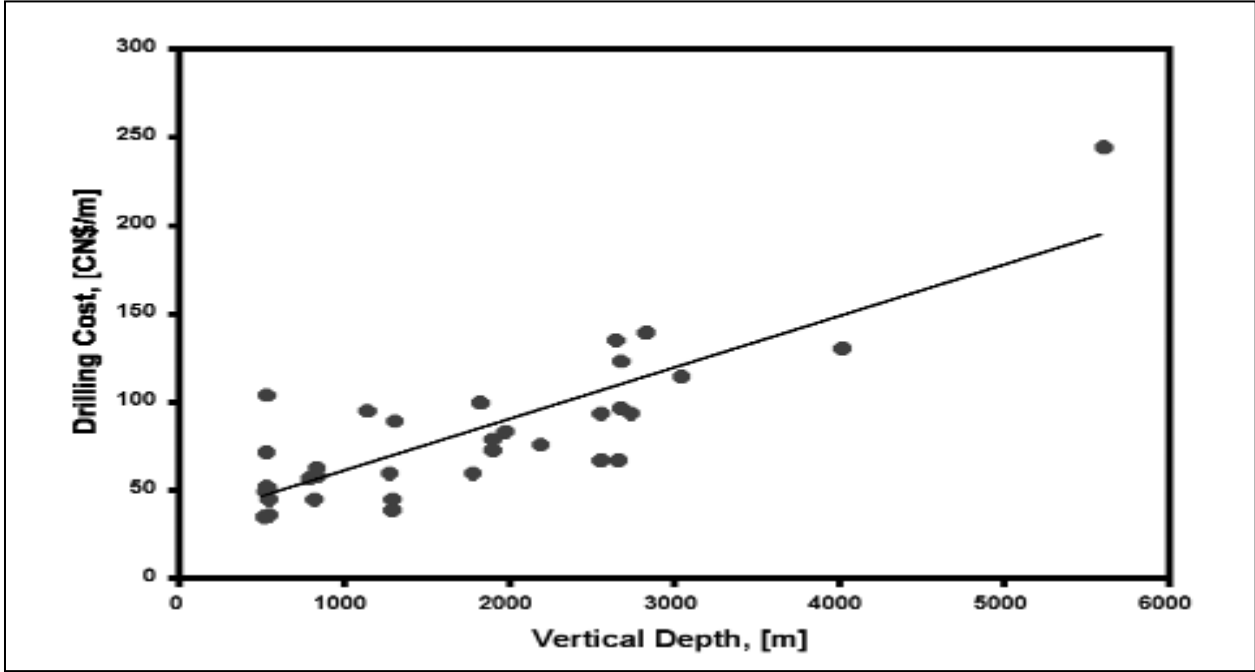

*Figure 2.4- Vertical depth and Drilling Cost*

The following equation form was used in the study to estimate cost of vertical section [22]:

$$\$Cost_v = 0.007 * D_{tv} + 12.069 \quad \text{-----Eq.22}$$

Expenses incur upon increased length of Horizontal drilling keep on increasing and the length to cost relationship can be specified as:

$$\text{\$Cost}_H = AL^n + B \quad \text{-----Eq.23}$$

The above relationship b/w horizontal well cost and length of horizontal section may not produce a linear relationship between the two variables but in this study, a linear relationship was used in between these two and a fixed rate of 1.5 times [1] the vertical cost was allocated to horizontal drilling and completion cost.

Construction cost per unit length was calculated as:

$$C_c = \frac{\text{\$Cost}_V}{D_{tV}} + \frac{\text{\$Cost}_H}{L} \quad \text{-----Eq.24}$$

Another assumption was made for Capital Cost allocation [1] and a rate of 15% of total investment cost or the construction cost was used.

Operating cost and Company overhead [1] was kept constant for all horizontal well lengths and numbers of wells drilled.

Taxes were calculated on the basis of before-federal-income-tax [1].

After assigning all the costs, Net Cash Flow (NCF) was obtained as a deduction of all costs from revenues which were expected to be obtained from trading of Hydrocarbon Products. Formula of NCF is presented as:

$$\begin{aligned} \sum NCF &= \sum \text{Revenue} - \sum \text{Operating Cost} - \sum \text{Overhead} \\ &\quad - \sum \text{Construction Cost} - \sum \text{Capital Cost} \\ &\quad - \sum \text{Taxes} \quad \text{-----Eq.25} \end{aligned}$$

NPV for NCF was calculated to account for depreciation of cash values using discount rates:

$$\sum NPV = (NCF_1)(DR_1) + (NCF_2)(DR_2) + \dots + (NCF_t)(DR_t)$$

$$\sum NPV = \sum_k^t (NCF_k)(DR_k) \quad \text{-----Eq.26}$$

$$\sum NPV = \sum_k^t \frac{NCF}{(1+i)^t} \quad \text{-----Eq.27}$$

Eq.27 can be used in place of Eq.26 if Discount rates are equal.

Revenues or the source of incomes are the selling of crude oil or Hydrocarbon products and it was calculated to be the product of Oil price and its production.

$$\sum Revenue (R) = Q^k \$_{oil}^k \text{-----Eq.28}$$

Yearly production was calculated as a function of following variables:

$$Q^k = f (N, L, q, D_k) \text{-----Eq.29}$$

Combining Eq.4, 6, 7 and 8, following equation was obtained:

$$(1 + i)^t \sum NPV = f (N, L, q, D_k) * \$_{oil}^k - C_o * t - C_h * t - C_c * t - C_p * t - C_t * t \text{ Eq.30}$$

Differentiating Eq.9 with respect to well length and putting its slope to zero provided optimum well length that would yield maximum NPV in the presence of well bore hydraulics i.e. frictional effects and well construction costs.

$$\frac{d[(1 + i)^t \sum NPV]}{dL} = \frac{d[f (N, L, q, D_k) * \$_{oil}^k - C_o * t - C_h * t - C_c * t - C_p * t - C_t * t]}{dL}$$

$$\frac{d[(1 + i)^t \sum NPV]}{dL} = \frac{d[f (N, L, q, D_k) * \$_{oil}^k]}{dL} - C_c \text{-----Eq.31}$$

By putting  $\frac{d[(1+i)^t \sum NPV]}{dL}$  equal to zero, optimal well length can be calculated as:

$$\frac{d[f (N, L, q, D_k) * \$_{oil}^k]}{dL} = C_c \text{-----Eq.32}$$

**2.9.2 Results by Hyun Cho, SPE, Kellogg Brown & Root Inc.**

Hyun Cho [1] obtained results of Productivity Index variation shown in fig 2.5 with well length using different drawdowns. He pointed out that the PI curves flattened in each case after reaching a certain point and no more productivity was obtained after this point by increasing well lengths.

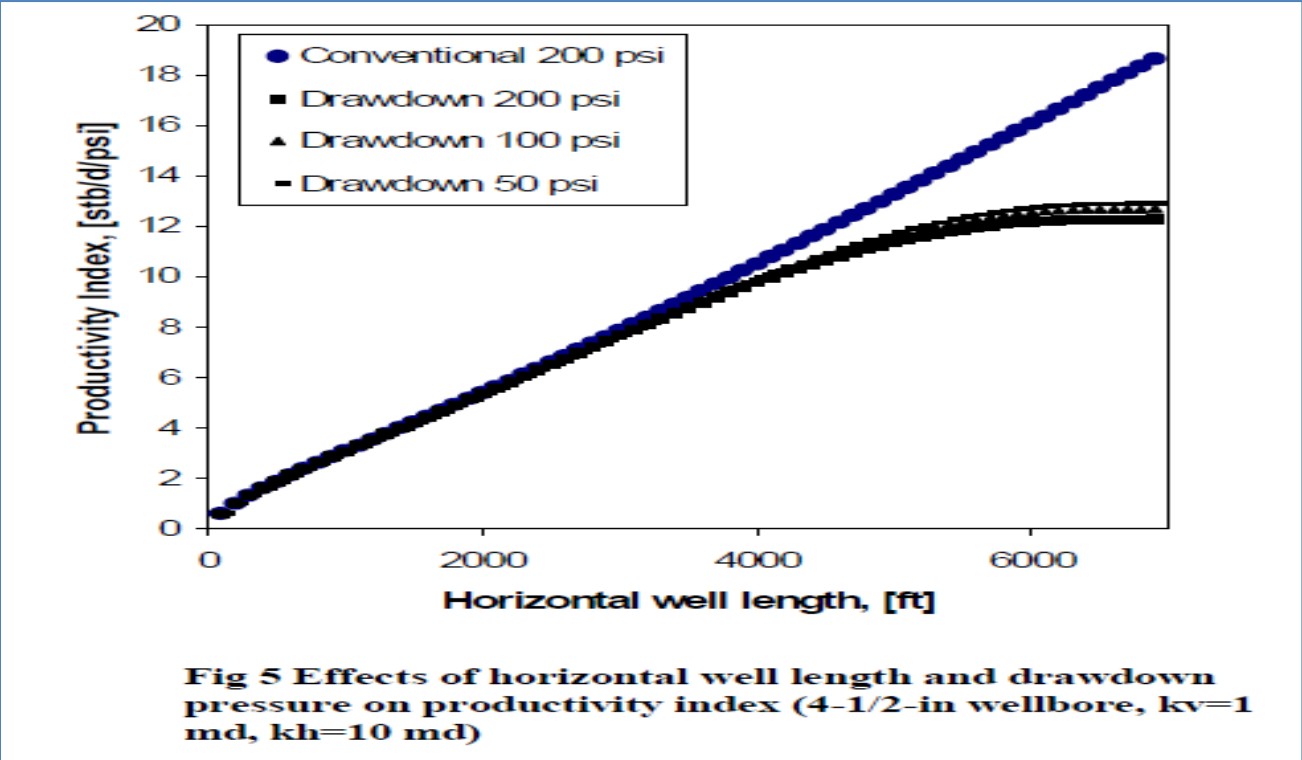

*Figure 2.5 Effects of Horizontal well length and drawdown pressures on productivity index [1] (4-1/2-in wellbore,  $k_v=1$  md,  $k_h = 10$  md)*

He [1] stated that increase in wellbore diameter operating under different (fig 2.6) drawdowns with variations in Horizontal and vertical permeability yielded different oil production rates after the threshold length. Although each production rate curve flattened after some time, but the bigger diameter well lengths were less influenced by wellbore frictional pressure drops.



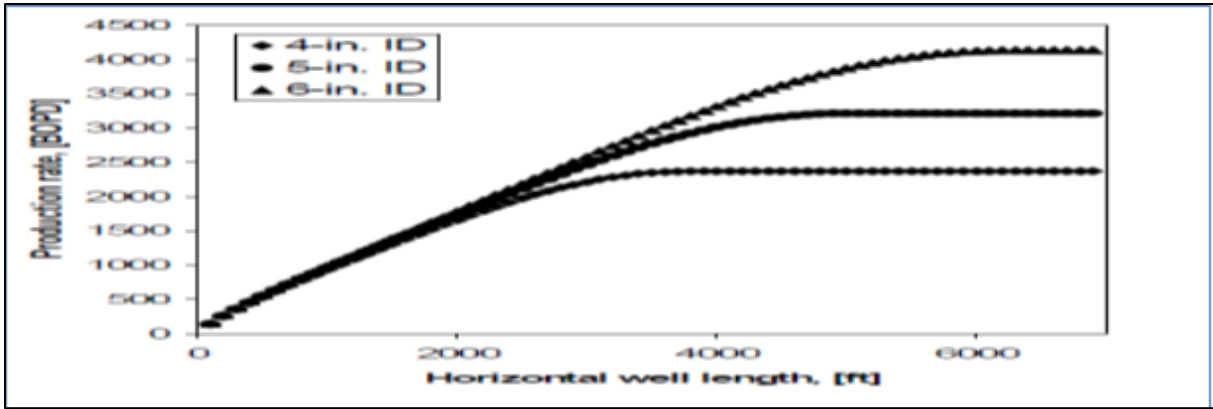

*Figure 2.6 Effects of wellbore diameters on production rate [1]  
(150 psi drawdown pressure,  $k_v = 1$  md and  $k_h =$  md)*

Well bore roughness also had its impact on results (fig 2.7) and the well length having highest amount of wellbore roughness was most affected by wellbore pressure drops.

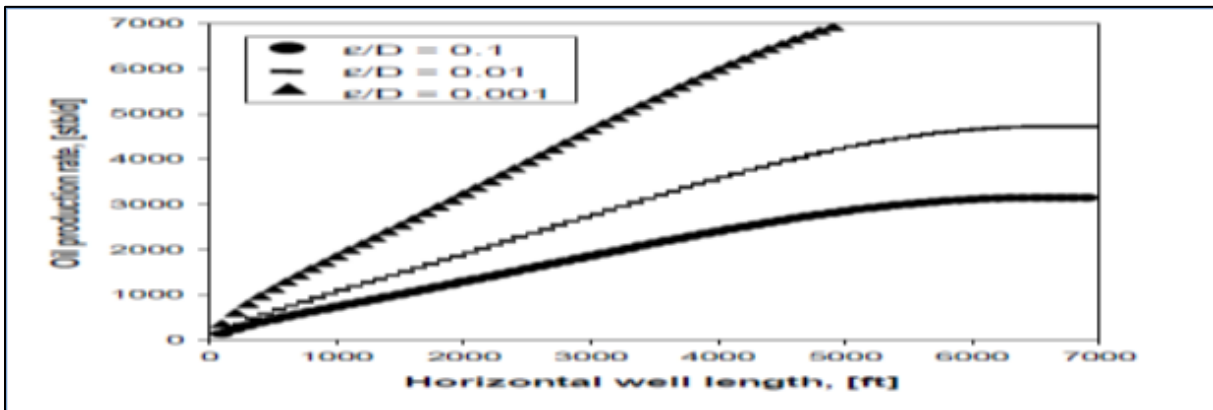

*Figure 2.7 Effects of wellbore roughness on production rate [1] (4-1/2- in wellbore, 150 psi drawdown pressure,  $k_v = 1$  md,  $k_h = 10$  md)*

### 2.9.3 Optimum well length

Hyun Cho [1] mentioned that after any field discovery, parameters such as economics of development wells, hydrocarbon markets and regulatory requirements affect field development progress.

He added that although the parameters such as reserves estimation, aquifer support, inflow performance, well spacing and tubing performance also affect Economics, but those were out of this study scope.

Fig 2.8 from Hyun Cho results [1] shows the effect of NPV Revenue and Total cost variations with well length increase.

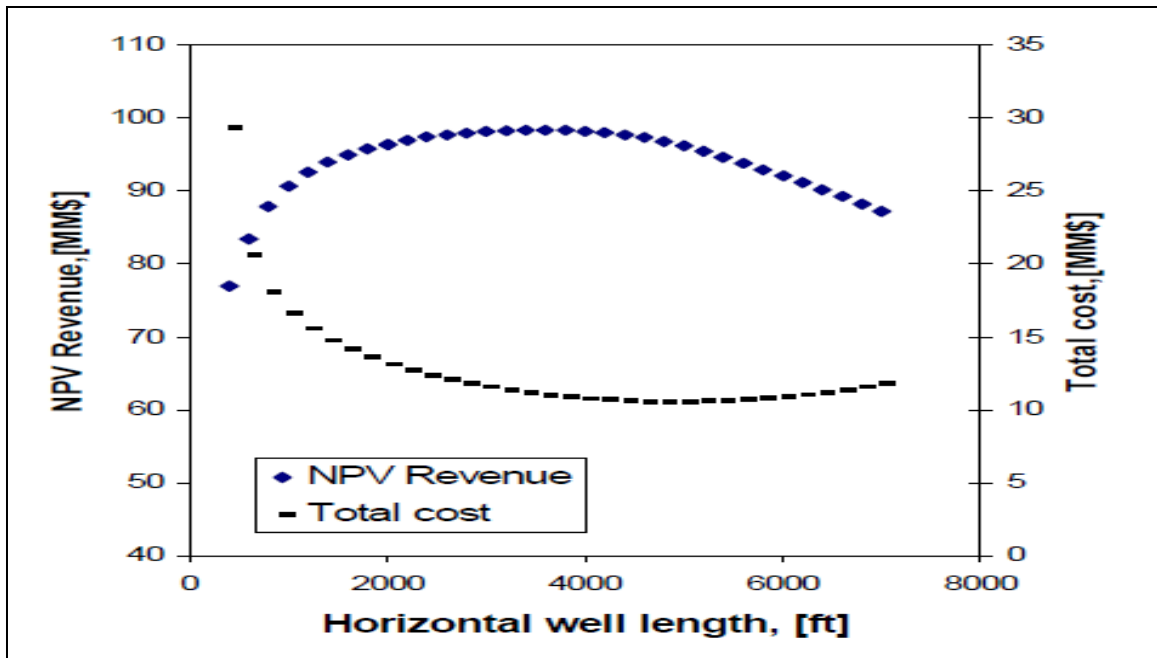

**Figure 2.8 NPV Revenue and Total Cost [1]**

Total cost is higher in shorter well lengths because large number of well were required to drain the total area. Although, as well length increased, this cost continued to decrease because of reduction in number of wells. In later stages, total cost increased slightly.

NPR Revenue continued to increase with increase in well lengths and number of wells before reaching a point where it started to decline. The difference of NPV revenue and total cost was found out to maximum for the 5 wells of lengths 4,000 ft each, therefore this length was reported as the optimal well length.

Fig 2.9 also showed the same results where NPV Project (NPV Revenue - Total Cost) reached its maximum point for 5 wells of length 4,000 ft each. The single well construction was reported in the figure as a linear function of well length.

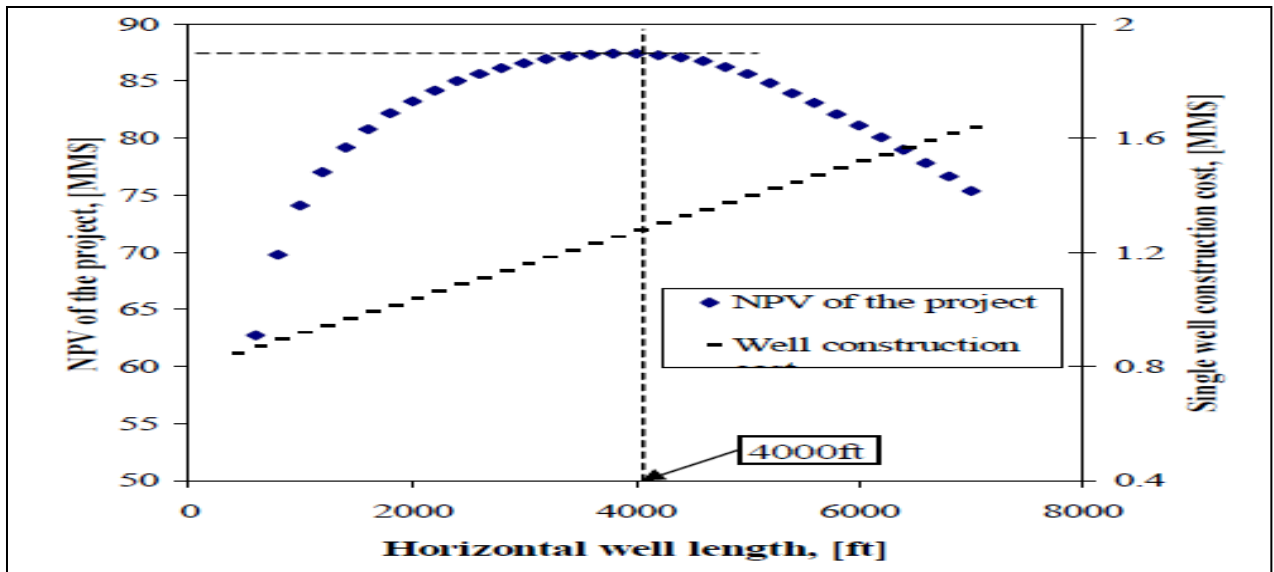

Figure 2.9 NPV of the project with optimum horizontal well length v/s single well construction cost [1]

#### 2.9.4 Comparison of results with NOVY method

Optimum well length obtained with the method proposed by Novy [12] were compared and found to be in good agreement. Novy, through his research based on well lengths, well diameters and production rates, provided a quick estimation of optimum well length as the one which produces 90% of maximum flow rate.

Fig 2.10 shows the comparison of two methods.

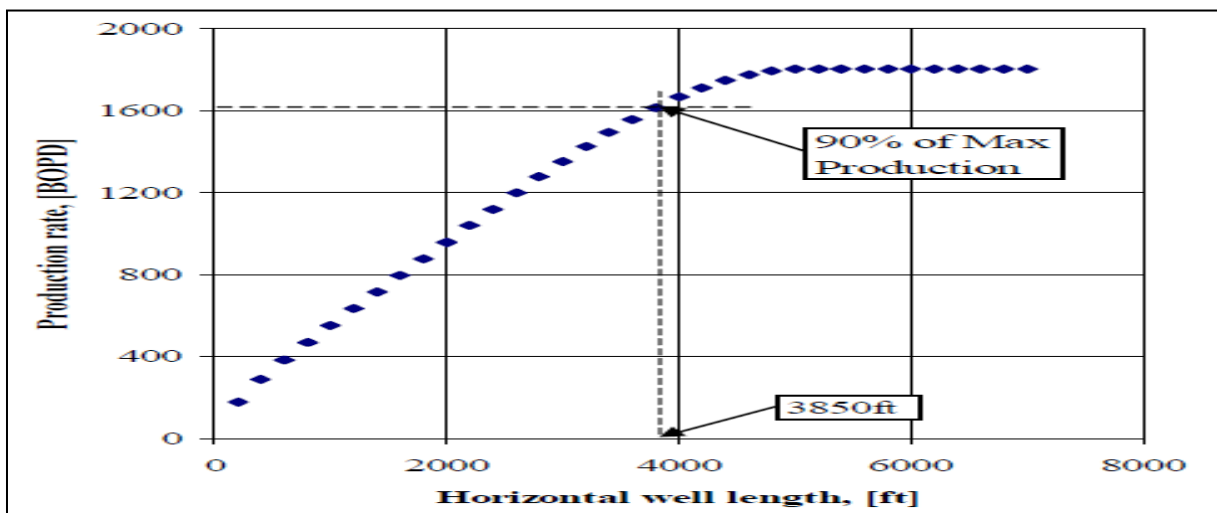

Figure 2.10 Productivity rate v/s horizontal well length calculated with the Novy Method

The difference of optimal lengths by Hyn Cho (4000 ft.) and Novy (3850 ft.) was only 150 ft.

### **3. THESIS WORK**

In this thesis work, I have tried to find out the optimum well length of the Horizontal well i.e. the length which would yield maximum productivity. This objective was carried out by this estimating NPV and Productivity Indices (PI) of following projects:

1. Drawdown limits on production wells using finite conductivity concept
2. Drawdown limits on production wells assuming constant well bore pressure
3. Variations in Wellbore roughness and tubing diameters using finite conductivity concept
4. Wells operating on Pressure control mode considering wellbore hydraulics

PI of the case when Pressure supplements to production well through injection well is also discussed.

#### **3.1 Data file**

The data file was taken from the Horizontal Well Simulation file in index of John Kleppe [23] SPE Comparative Eclipse data. The data file is used to simulate the performance of Horizontal well and compare it with results of simulation runs reported in Seventh SPE Comparative Solution Project [24]. This data file was designed to simulate production from the horizontal well in an area where coning behavior was essential and the effects of well length & effects of flow rates on the recovery were to be determined.

#### **3.2 Simulation Software**

Simulation was performed in software Eclipse. Eclipse, a black oil simulator that can be used to model one, two or three-phases. It's a fully implicit simulator that can handle gas condensate options.

### 3.3 Model Description

The model deals with the oil recovery by depletion in a thin reservoir. 3-D model was formed by 19x9x6 grid system. A Horizontal well is drilled in the first layer at the depth of 3600 ft. and its length has changed considerably throughout the work. Comprising of 17 different lengths, from a minimum length of 100 ft., a well up to the length of 7200 ft. is considered.

This thesis work has run 6 cases, 5 of which have used all well lengths i.e. from 100 ft. to 7200 ft. whereas the last one has considered lengths from 100 ft. to 3600 ft. Each of 6 mentioned cases have 3 subcases as well. The cases have the following salient features:

- Case-1 simulates wellbore hydraulic effects on NPV and productivity index on wells producing in 3 different drawdown limits.
- Case-2 simulates Infinite Conductivity effects on NPV and productivity index on wells producing in 3 different drawdown limits.
- Case-3 simulates wellbore hydraulic effects on NPV and productivity index on wells producing from wellbores having 3 different values of roughness.
- Case-4 simulates wellbore hydraulic effects on NPV and productivity index on wells producing from wellbores having 3 different values of wellbore diameters.
- Case-5 simulates wellbore hydraulic effects on NPV and productivity index on wells producing in 3 different bottom hole flowing pressure conditions.
- Case-6 simulates wellbore hydraulic effects on productivity index on wells producing in 3 different flow rate conditions with support from injection wells.

### 3.4 Control Data for Production Wells

#### 3.4.1 Case-1: Well bore Hydraulic Effects (Bottom hole flowing pressures)

Table 3.1 Control data for Case-1

Control Data	Case-1 (a)	Case-1 (b)	Case-1 (c)
Name of well	PROD	PROD	PROD
Horizontal Length	100-7200 ft.	100-7200 ft.	100-7200 ft.
Wellbore Friction	Yes	Yes	Yes
Horizontal perm	300 md	300 md	300 md
Vertical Perm	30 md	30 md	30 md
Minimum BHP	3000 Pisa	3200 Pisa	3400 Pisa
Well Control Mode	BHP	BHP	BHP
Simulation Time	5 years	5 years	5 years
Wellbore diameter	2.5 inch ID.	2.5 inch ID.	2.5 inch ID.
Well bore roughness	0.0002083	0.0002083	0.0002083

#### 3.4.2 Case-2: Well bore Hydraulic Effects (Drawdown Limits)

Table 3.2 Control data for Case-2

Control Data	Case-2 (a)	Case-2 (b)	Case-2 (c)
Name of well	PROD	PROD	PROD
Horizontal Length	100-7200 ft.	100-7200 ft.	100-7200 ft.
Oil rate	2000 stb/day	2300 stb/day	2500 stb/day
Wellbore Friction	Yes	Yes	Yes
Horizontal perm	300 md	300 md	300 md
Vertical Perm	30 md	30 md	30 md
Minimum BHP	500 Pisa	500 Pisa	500 Pisa
Well Control Mode	Oil rate	Oil rate	Oil rate
Simulation Time	5 years	5 years	5 years
Drawdown Limit	50 psia	300 psia	700 psia
Wellbore diameter	2.5 inch ID.	2.5 inch ID.	2.5 inch ID.
Well bore roughness	0.0002083	0.0002083	0.0002083

#### 3.4.3 Case-3: Infinite Conductivity (Drawdown Limits)

All parameters of Case-3(a), Case-3(b) and Case-3(c) are same when compared to respective cases in Case-2 except that the Wellbore Friction Extension which is turned off.

### 3.4.4 Case-4:

#### Well bore Hydraulic Effects (Wellbore roughness)

*Table 3.3 Control data for Case-4*

Control Data	Case-4 (a)	Case-4 (b)	Case-4 (c)
Name of well	PROD	PROD	PROD
Horizontal Length	100-7200 ft.	100-7200 ft.	100-7200 ft.
Oil rate	1600 stb/day	1600 stb/day	1600 stb/day
Wellbore Friction	Yes	Yes	Yes
Horizontal perm	300 md	300 md	300 md
Vertical Perm	30 md	30 md	30 md
Minimum BHP	500 Pisa	500 Pisa	500 Pisa
Well Control Mode	Oil rate	Oil rate	Oil rate
Simulation Time	5 years	5 years	5 years
Drawdown Limit	100 psia	100 psia	100 psia
Wellbore diameter	2.5 inch ID.	2.5 inch ID.	2.5 inch ID.
Well bore roughness	0.001	0.01	0.01

### 3.4.5 Case-5:

#### Well bore Hydraulic Effects (Wellbore diameter)

*Table 3.4 Control data for Case-5*

Control Data	Case-5 (a)	Case-5 (b)	Case-5 (c)
Name of well	PROD	PROD	PROD
Horizontal Length	100-7200 ft.	100-7200 ft.	100-7200 ft.
Oil rate	2600 stb/day	2600 stb/day	2600 stb/day
Wellbore Friction	Yes	Yes	Yes
Horizontal perm	300 md	300 md	300 md
Vertical Perm	30 md	30 md	30 md
Minimum BHP	500 Pisa	500 Pisa	500 Pisa
Well Control Mode	Oil rate	Oil rate	Oil rate
Simulation Time	5 years	5 years	5 years
Drawdown Limit	100 psia	100 psia	100 psia
Wellbore diameter	3.6 inch ID.	4.8 inch ID.	6.0 inch ID.
Well bore roughness	0.01	0.01	0.01

### 3.4.6 Case-6:

#### Well bore Hydraulic Effects (Injection Well Support)

Table 3.5 Control data for Case-6

Control Data	Case-6 (a)	Case-6 (b)	Case-6 (c)
<b>Name of well</b>	PROD	PROD	PROD
<b>Horizontal Length</b>	100-3600 ft.	100-3600 ft.	100-3600 ft.
<b>Liquid Rate</b> (oil + water)	1000 stb/day	2000 stb/day	3000 stb/day
<b>Wellbore Friction</b>	Yes	Yes	Yes
<b>Horizontal perm</b>	300 md	300 md	300 md
<b>Vertical Perm</b>	30 md	30 md	30 md
<b>Minimum BHP</b>	500 Pisa	500 Pisa	500 Pisa
<b>Well Control Mode</b>	Liquid rate	Liquid rate	Liquid rate
<b>Simulation Time</b>	5 years	5 years	5 years
<b>Wellbore diameter</b>	4.5 inch ID.	4.5 inch ID.	4.5 inch ID.
<b>Well bore roughness</b>	0.000375	0.000375	0.000375

#### Case-6 Injection Well Details

Operational Condition	Case-6 (a)	Case-6 (b)	Case-6 (c)
<b>Name of well</b>	INJ	INJ	INJ
<b>Horizontal Length</b>	2700 ft.	2700 ft.	2700 ft.
<b>Well Control Mode</b>	BHP	BHP	BHP
<b>Maximum BHP</b>	3700 psia	3700 psia	3700 psia



### 3.7 Black Oil and Relative Permeability data

Black Oil and Relative permeability data was taken from the second SPE Comparative Solution Project [25] after Slight modification in table 3.7.2.

#### 3.7.1 Fluid Property Data

*Table 3.6 Fluid Property Data for simulation data file*

Pressure	$B_o$	$B_g$	$R_s$	$\mu_o$	$\mu_g$
psia	rb/stb	Rb/scf	scf/stb	cp	Cp
800	1.0255	0.00295	335	1.14	0.0135
1200	1.0380	0.00196	500	1.11	0.0140
1600	1.0510	0.00147	665	1.08	0.0145
2000	1.0630	0.00118	828	1.06	0.0150
2400	1.0750	0.00098	985	1.03	0.0155
2800	1.0870	0.00084	1130	1.00	0.0160
3600	1.1100	0.00065	1390	0.95	0.0170
4000	1.1200	0.00059	1500	0.94	0.0175
4400	1.1300	0.00054	1600	0.92	0.0180
4800	1.1400	0.00049	1676	0.91	0.0185
5200	1.1480	0.00045	1750	0.90	0.0190
5600	1.1550	0.00042	1810	0.89	0.0195

#### 3.7.2 Relative Permeability and Capillary Pressure

*Table 3.7 Relative Permeability Data for simulation data file*

$S_w$	$k_{rw}$	$K_{row}$	$P_{cow}$ (psia)
0.20	0.00	1.0000	0.90
0.35	0.07	1.4000	0.80
0.40	0.15	0.1250	0.70
0.50	0.24	0.0649	0.60
0.60	0.33	0.0048	0.50
0.70	0.49	0.0000	0.40
0.80	0.65	0.0000	0.3
1.00	1.00	0.0000	0.00

$S_g$	$k_{rg}$	$k_{rog}$	$P_{cgo}$ (psia)
0.00	0.0000	1.00	0.0
0.10	0.0220	0.33	0.5
0.20	0.1000	0.10	1.0
0.30	0.2400	0.02	1.5
0.40	0.3400	0.00	2.0
0.50	0.4200	0.00	2.5
0.60	0.5000	0.00	3.0
0.78	1.0000	0.00	3.9

### 3.8 Reservoir Data

Following data was taken form [23]

#### 3.8.1 Grid Block Dimensions in x direction

No. of Grid blocks differ from the [23] and dimensions of 19 grid block dimensions were set to be 450 ft. each. (300 ft. for Case-6).In the cases, where well length were taken 100 ft., 18<sup>th</sup> grid block in the x-direction has changed to 100 ft.

#### 3.8.2 Grid Block Dimensions in y direction

No. of Grid Blocks in y-direction was set same as [23] and dimensions were also unchanged.

*Table 3.8 y-Direction grid block sizes in simulation input*

Y-direction grid blocks	Dimensions (ft.)
1	620
2	400
3	200
4	100
5	60
6	100
7	200
8	400
9	620

### 3.8.3 Grid Block Dimensions in z direction

*Table 3.9 z-Direction grid block sizes in simulation input*

Layer	Thickness ( $\Delta z$ ) ft.	Depth to center of layer (ft.)
1	20	3600
2	20	3620
3	20	3640
4	20	3660
5	30	3685
6	50	3725

### 3.9 Well location/Completion data

As there were 17 different lengths of horizontal wells considered in Case-1 to Case-5 and 13 lengths for Case-6, following are those details:

*Table 3.10 Well Location/Completion Data in simulation input*

(Case-1to5) length	(Case-6) length	x-direction grid block	x-direction grid block	y-direction grid block	z-direction grid block
(ft.)	(ft.)	(heel)	(toe)	-	-
100	100	18	18	5	1
450	300	18	18	5	1
900	600	18	17	5	1
1350	900	18	16	5	1
1800	1200	18	15	5	1
2250	1500	18	14	5	1
2700	1800	18	13	5	1
3150	2100	18	12	5	1
3600	2400	18	11	5	1
4050	2700	18	10	5	1
4500	3000	18	9	5	1
4950	3300	18	8	5	1
5400	3600	18	7	5	1
5850	-	18	6	5	1
6300	-	18	4	5	1
6750	-	18	5	5	1
7200	-	18	3	5	1

All Connections were set OPEN to flow. Well in each run was set to penetrate in x-direction. Well length was kept altered by using keyword COMPDAT.

### 3.10 Densities, Viscosities and Compressibility Data

*Table 3.11 Densities, Viscosities and compressibility Data in simulation input*

Stock tank Oil Density	45 lbm /ft <sup>3</sup>
Standard Condition gas density	0.0702 lbm/ft <sup>3</sup>
Standard condition water density	62.14 lbm/ft <sup>3</sup>
Under saturated oil compressibility	10 <sup>-5</sup> psia <sup>-1</sup>
Water Compressibility	3x10 <sup>-6</sup> psia <sup>-1</sup>
Water Viscosity	0.96
Water formation volume factor	1.0142 rb/stb

### 3.11 Well Specification data

*Table 3.12 Well Specification data in simulation input*

Reference depth for BHP	3600 ft.
Preferred phase for the well	Oil
Inflow equation	Standard

### 3.12 3-D Model Appearance

This is how the initial pressure distribution looks like at the start of the simulation i.e. 1<sup>st</sup> Jan 1990. Simulation results were viewed through software which is called S3-graf. Fig3.1 shows pressure distribution for the Case-1 when the well length was 100 ft and liquid flow rate was 2000 stb/day.

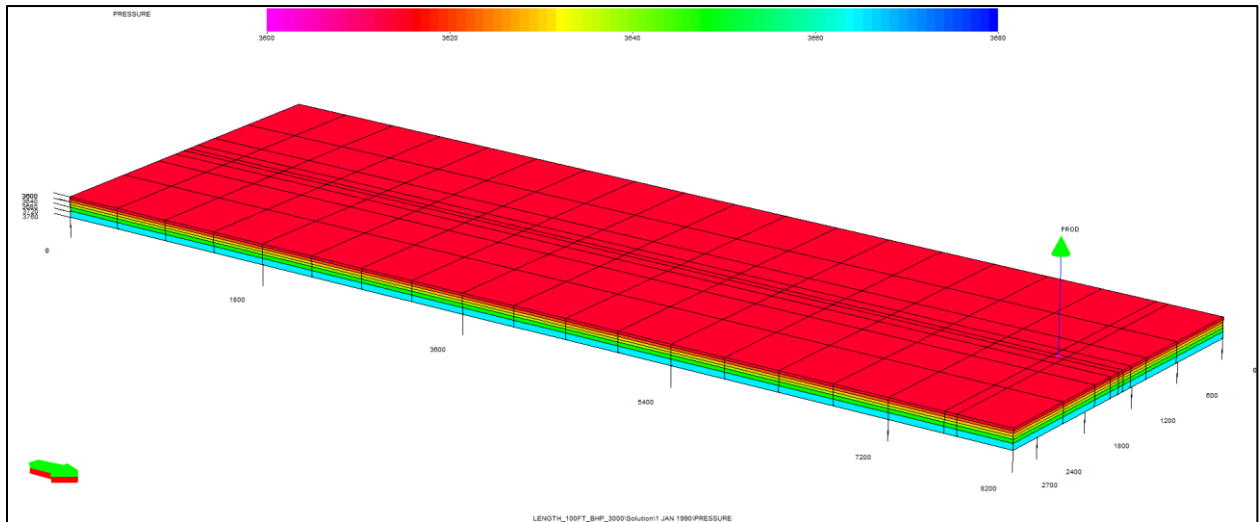

*Fig 3.1(a): Initial Pressure distribution of the simulation model for Cases-1 to 5*

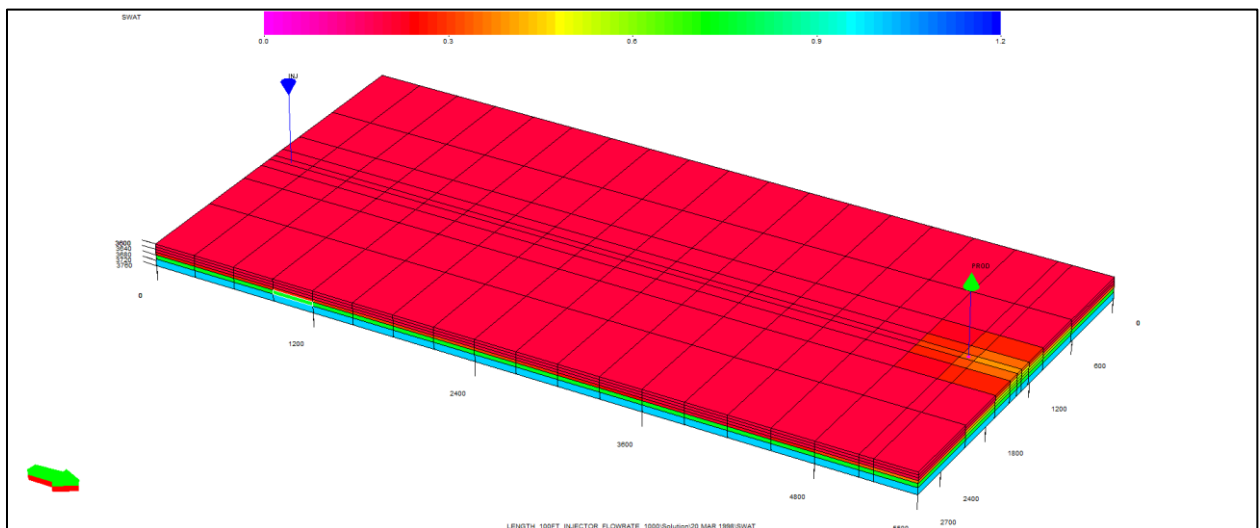

*Fig 3.1(b): Initial Pressure distribution of the simulation model for Case-6*

Only 5 Well Locations from 17 locations are represented below  
form Fig 3.2(a) to Fig 3.2(e)

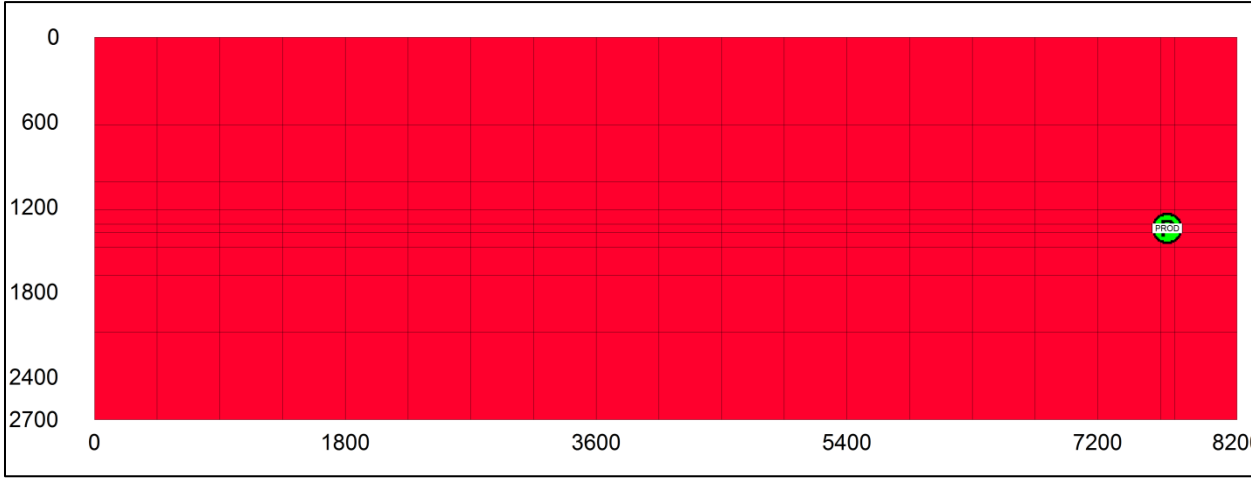

Figure 3.2(a) 100 ft. well length

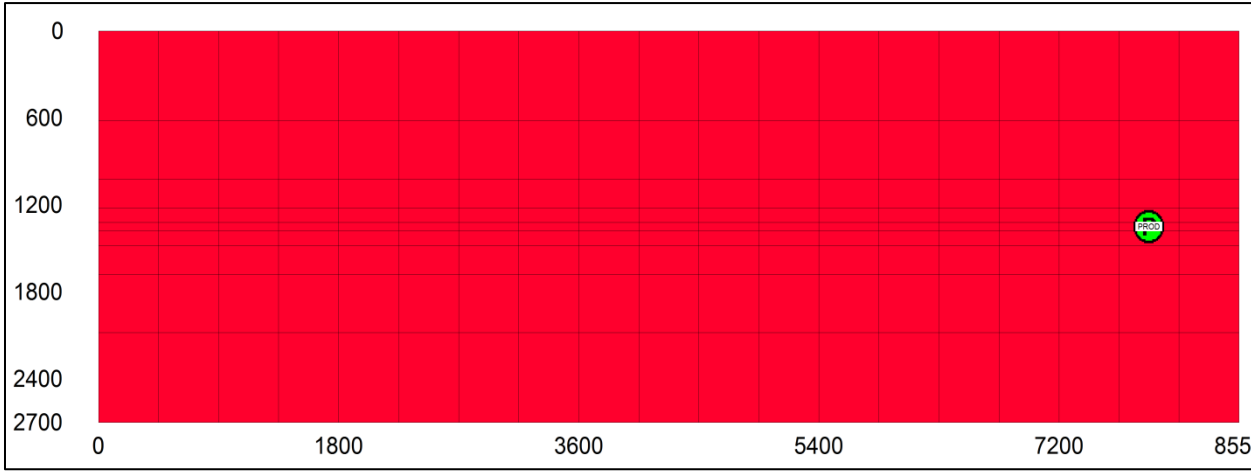

Figure 3.2(b) 450 ft. well length

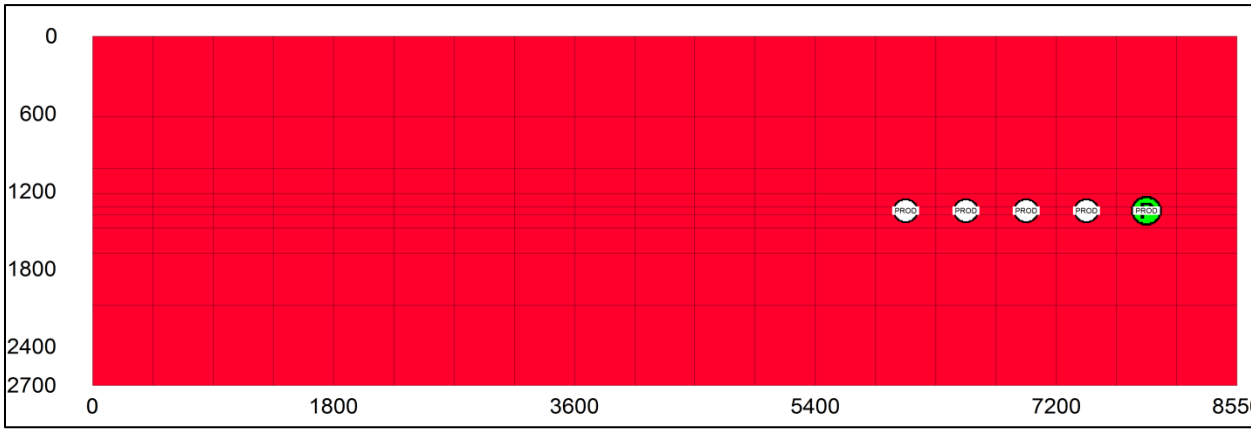
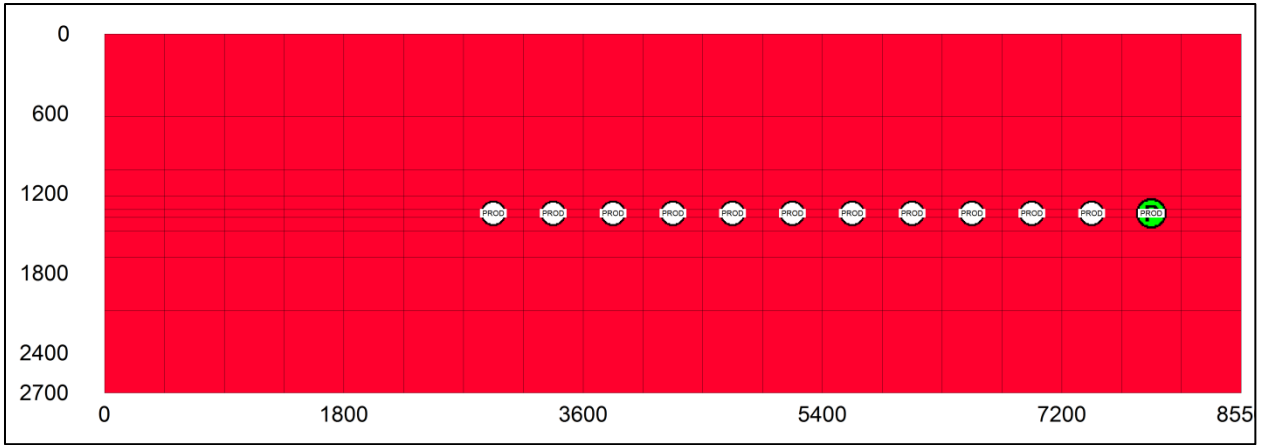
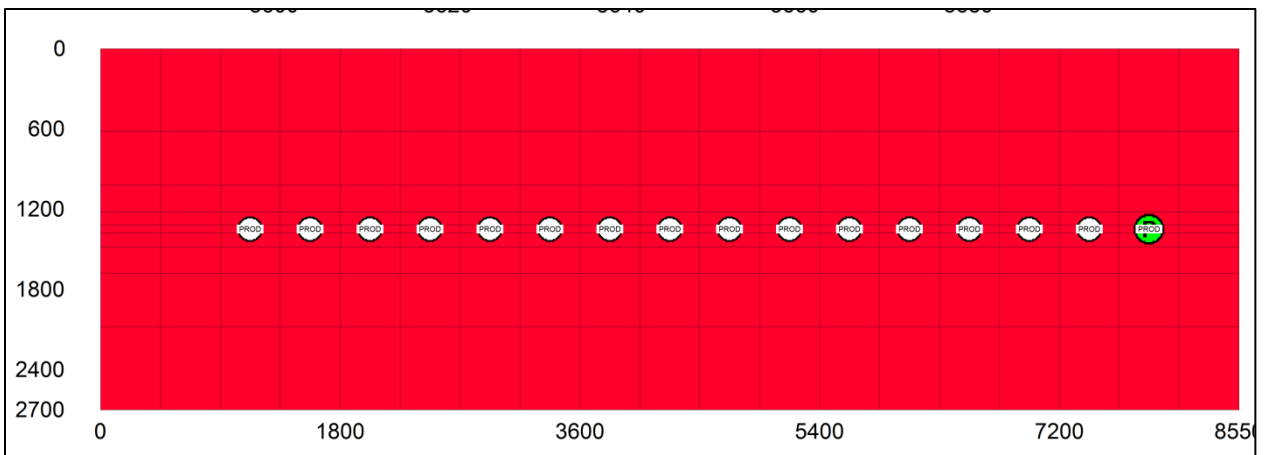

Figure 3.2(c) 2250 ft. well length



*Figure 3.2(d) 5400 ft. well length*



*Figure 3.2(e) 7200 ft. well length*

### 3.13 Calculation of Productivity Index

Productivity index,  $J$ , of the well is simply calculated through the ratio of flow rate to the drawdown.

$$J = \frac{q}{\bar{p} - p_{wf}} \quad \text{Eq. 33}$$

Flow rate ( $q$ ) is the function of number of flowing fluids, velocities, densities and viscosities of the fluids and in short the flow properties and the wellbore properties.

Average reservoir pressure,  $\bar{p}$  is the volumetric average pressure deployed by the reservoir fluids during depletion [26] and flowing bottom hole pressure,  $p_{wf}$  is the pressure measured at the top of the perforated interval. In case of horizontal well, bottom hole pressure is the pressure at or near the heel of the well.

Using Summary Section of Eclipse data file, outputs of the following keywords were obtained for all simulation time steps:

**Table 3.13 Summary Keyword used in Data file**

Keyword	Information	Units
FOPR	Field Oil Production Rate	stb/day
FWPR	Filed Water Production Rate	stb/day
FGPR	Field Gas Production Rate	stb/day
FLPR	Field Liquid Production Rate	stb/day
FOPT	Field Oil Production Total	stb
FWPT	Field Water Production Total	stb
FGPT	Field Gas Production Total	Mscf
FLPT	Field Liquid Production Total	Stb
FWCT	Field Water Cut Total	-
FGOR	Field Gas Oil Ratio	Mscf/stb
FOE	Field Oil Efficiency	-
FPR	Field Pressure average Value	psia
WBHP	Well Bottom hole pressure	psia
CPR (x, y, z)	Connection pressure at toe	psia



Drawdown pressures at each time step were calculated as:

$$\text{Drawdown} = (FPR - WBHP) \quad \text{in psia} \quad \text{Eq.34}$$

At each time step, PI was calculated through the following formula:

$$PI = \frac{FLPR}{(FPR - WBHP)} \quad \text{in} \quad \frac{\text{stb}}{\text{day}}/\text{psia} \quad \text{Eq.35}$$

Wellbore pressure drops at each time step were calculated as:

$$(\Delta p) = (CPR_{toe} - WBHP) \quad \text{in psia} \quad \text{Eq.36}$$

Wellbore pressure drops at the percentage of the drawdown were calculated as:

$$\Delta p \text{ (in \%)} = \frac{CPR_{toe} - WBHP}{FPR - WBHP} * 100 \quad \text{Eq.37}$$

### 3.14 NPV Calculations

#### 3.14.1 For single well

All Revenues were calculated from the production amounts of oil and gas. Using keywords 'FOPT' and 'FGPT', Field Oil and Gas Production per year were obtained and multiplied with yearly average oil and gas to come up with Revenues.

Operating Costs (keeping constant for all lengths) were obtained from a report [27] discussing operating and equipment cost of vertical wells in different parts of world. These operating costs were transformed to vertical costs with a help of following formula:

$$O.C.(\text{Horizontal}) = O.C.(\text{vertical}) \left( 1 + \frac{\text{Vertical depth}}{\text{shortest well length}} \right) \quad \text{---Eq.38}$$

Overhead Cost was calculated with the same Eq.38 after obtaining those from PSAC Well Cost Study [28].

Construction Cost and Capital Costs were calculated in the same manner suggested by [1].

Two types of taxes were used in the study. One of those was the fixed one (Royalty) and the 2<sup>nd</sup> one was concerned with selling of Wellhead Oil and Gas products. Royalty was charged with the rate of 3400 \$ per acre per year and selling of wellhead products was charged with 28%.

Net Cash flows were calculated through deducting all costs and taxes from Revenues as given in Eq.25.

$$\begin{aligned} \sum NCF = & \sum Revenue - \sum Operating Cost - \sum Overhead \\ & - \sum Construction Cost - \sum Capital Cost \\ & - \sum Taxes \quad \text{-----Eq.25} \end{aligned}$$

Net Cash flows were converted to Net Present Values using Eq. 27. Discount rate of 8% was used for all years.

$$\sum NPV = \sum_k^t \frac{NCF}{(1+i)^t} \quad \text{-----Eq.27}$$

NPV Revenue and NPV cost were calculated in the same manner as given in Eq. 27. For the case of NPV Revenue, NCF from Eq.27 was replaced with yearly revenue and for NPV Cost, NCF was substituted by total cost incurred per year.

### 3.14.2 Drainage area for a single horizontal well

Drainage area for a single horizontal well was obtained through method given by Joshi [2].

Joshi, in the first method represented drainage area for a single well as two half circles of radius equal to effective vertical well radius. Effective vertical well radius for 40 acre well spacing was calculate to be 745 ft. [2]

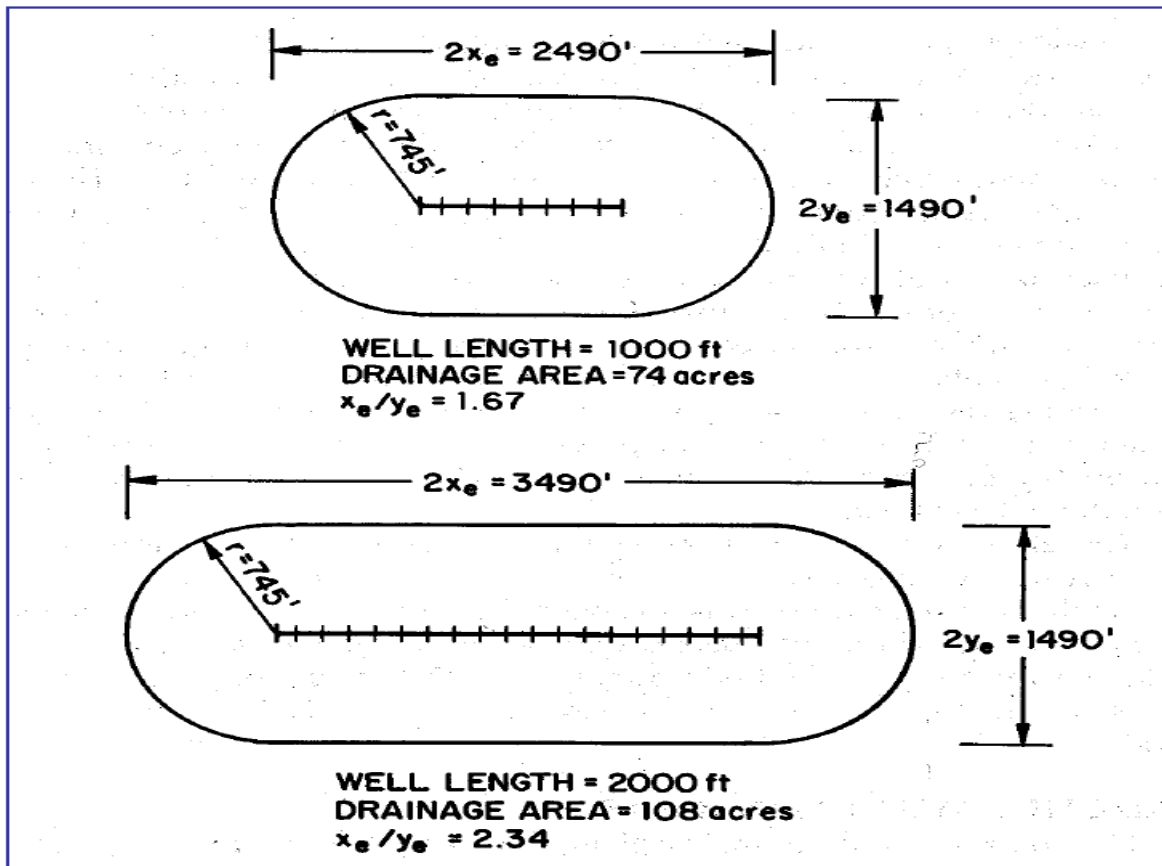

Figure 3.3 Drainage areas for Horizontal well presented by Joshi [2]

Following formula was used for calculating Horizontal well drainage area:

$$\text{Drainage area} = \frac{[\text{Area of 2 semi circles} + \text{Area of Rectangle}]}{43560}$$

$$\text{Drainage area} = \frac{[2(\pi r_{ev})^2 + 2 * r_{ev} * (\text{horizontal well length})]}{43560}$$

$$\text{Drainage area} = 2 * r_{ev} \frac{[(\pi r_{ev}) + (\text{horizontal well length})]}{43560} \text{ ----- Eq. 39}$$

In 2<sup>nd</sup> method, Joshi presented Drainage area of Horizontal well as an ellipse having major and minor axis of length 2a and 2b respectively.

Half of major and minor axes were calculated as:

$$a = \frac{\text{Horizontal well length}}{2} + r_{ev} \quad \text{----- Eq. 40(a)}$$

$$b = r_{ev} \quad \text{----- Eq. 40 (b)}$$

Further, Drainage area was obtained as:

$$\text{Drainage area} = \frac{[\pi(\text{half of major axis})(\text{half of minor axis})]}{43560}$$

$$\text{Drainage area} = \frac{[\pi ab]}{43560} \quad \text{----- Eq. 41}$$

As these two methods gave different estimates of drainage radius, average of these was taken. This average value of drainage area was then divided by field area to obtain number of wells required for each well length.

### 3.14.3 NPV for more than 1 well

NPV project, NPV Revenue and NPV cost for single wells were multiplied by number of wells required in the case of different well lengths.

### 3.15 Plotting of Graphs

Following graphs were plotted in Case-1 to Case-5

1. NPV revenue and Total cost v/s Horizontal well length
2. NPV project & single well construction cost v/s Horizontal well length
3. Productivity Index v/s Horizontal well length
4. Oil Well production rate v/s Horizontal well length  
(See Appendix)
5. Oil recovery v/s Horizontal well length (See Appendix)
6. Well bottom hole pressure v/s Horizontal well length  
(See Appendix)

Following graphs were plotted in Case-6

1. Productivity Index v/s Horizontal well length
2. Oil Well production rate v/s Horizontal well length  
(See Appendix)
3. Oil recovery v/s Horizontal well length (See Appendix)
4. Well bottom hole pressure v/s Horizontal well length (See Appendix)

## 4. SIMULATION RESULTS

### 4.1 Case-1 (a)

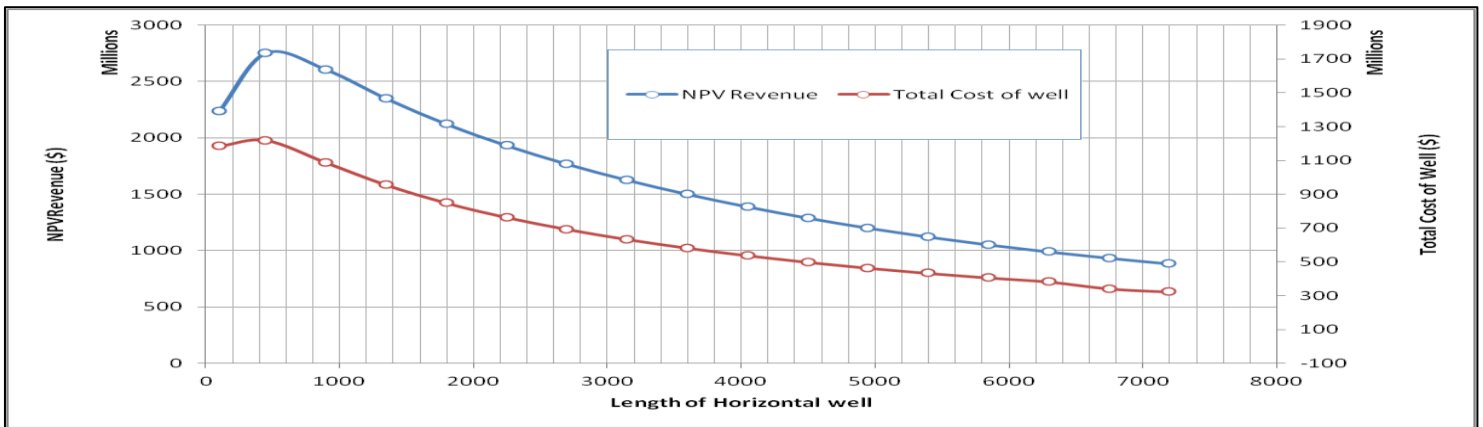

Fig 4.1 NPV and Total Cost v/s Horizontal Well Length for Case-1(a)

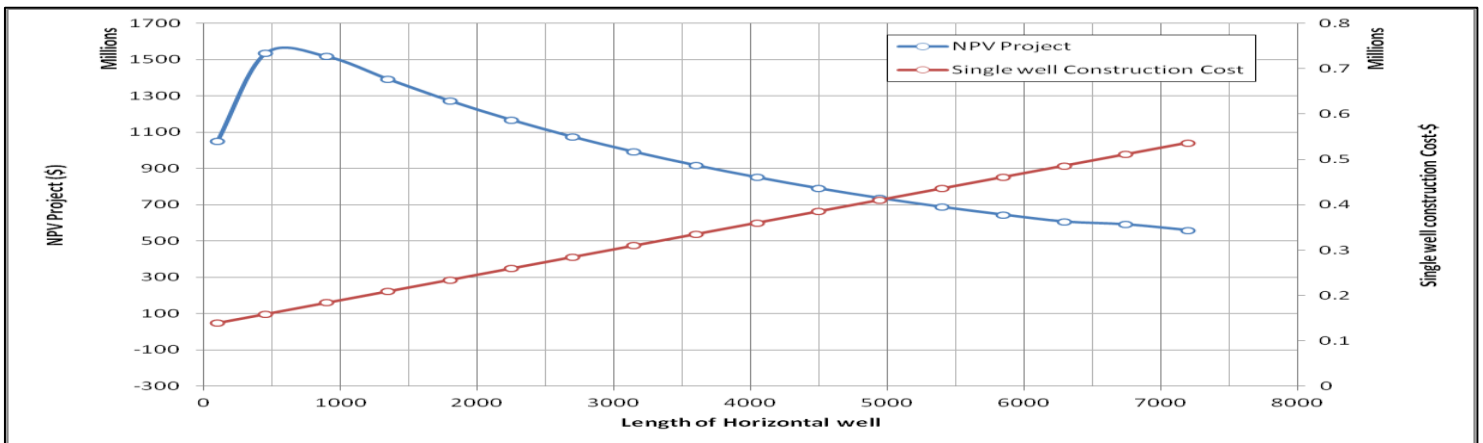

Fig4.2 NPV project and Single Well Construction Cost v/s Horizontal Well Length for Case-1(a)

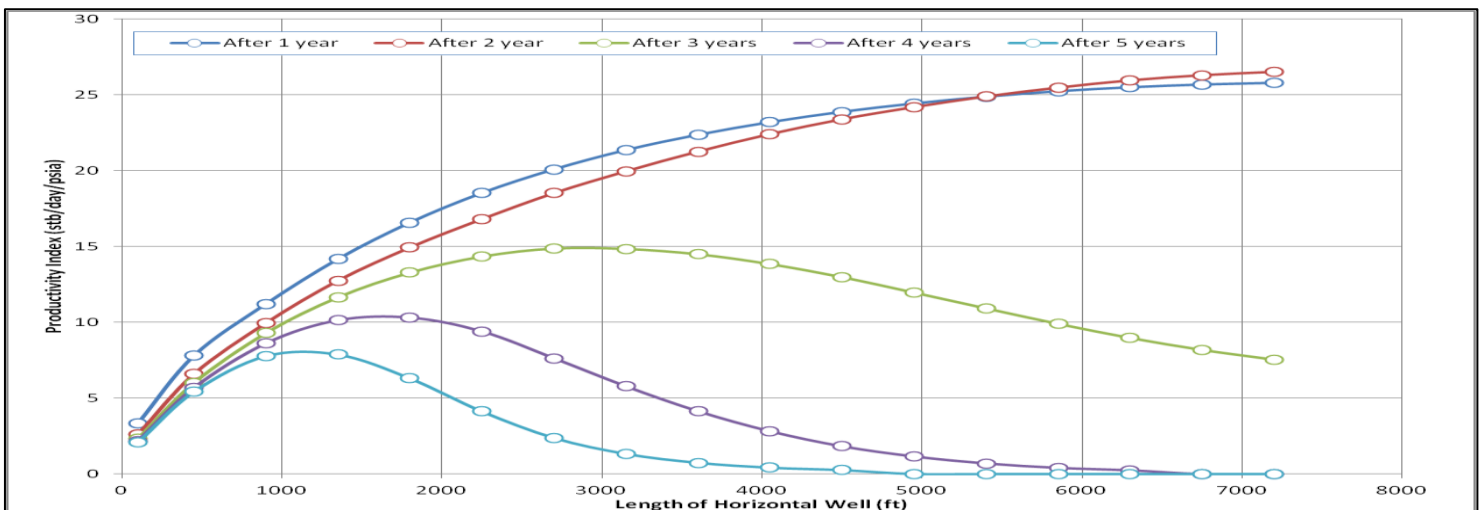

Fig4.3 Productivity Index v/s Horizontal Well Length for Case-1(a)

## 4.2 Case-1 (b)

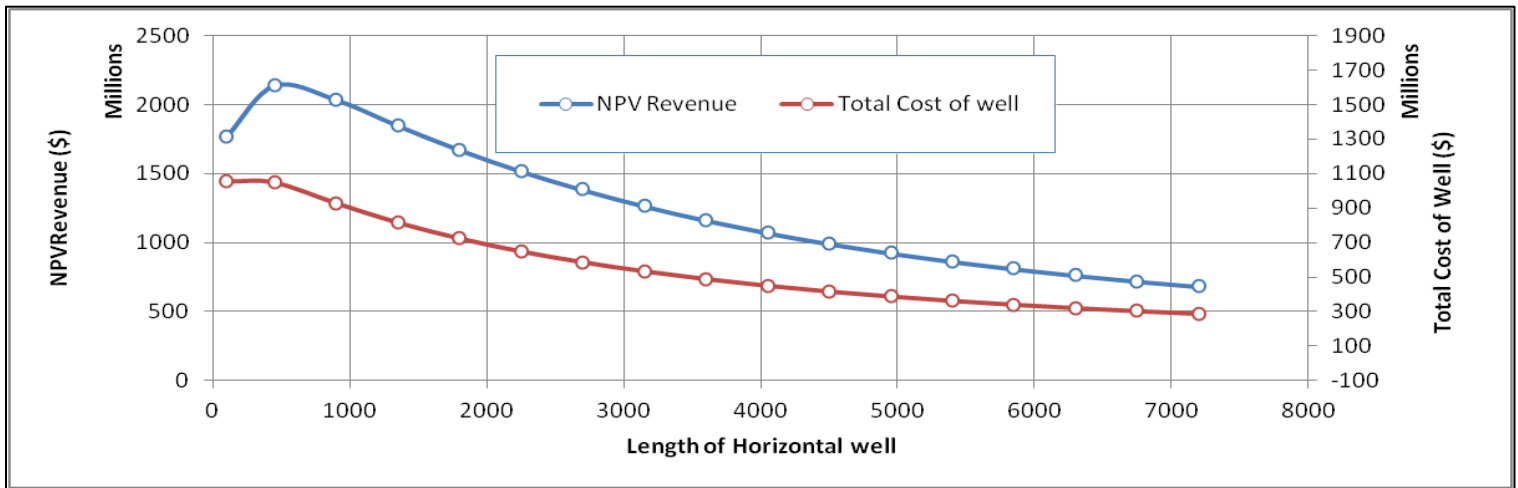

Fig 4.4 NPV and Total Cost v/s Horizontal Well Length for Case-1(b)

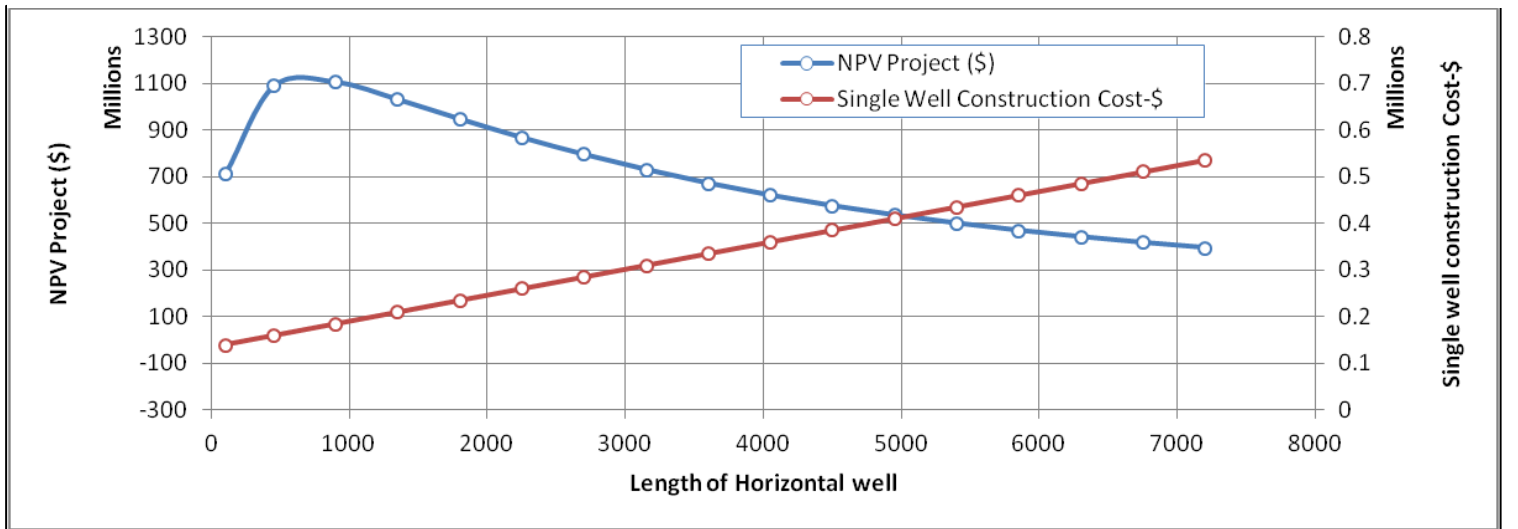

Fig4.5 NPV project and Single Well Construction Cost v/s Horizontal Well Length for Case-1(b)

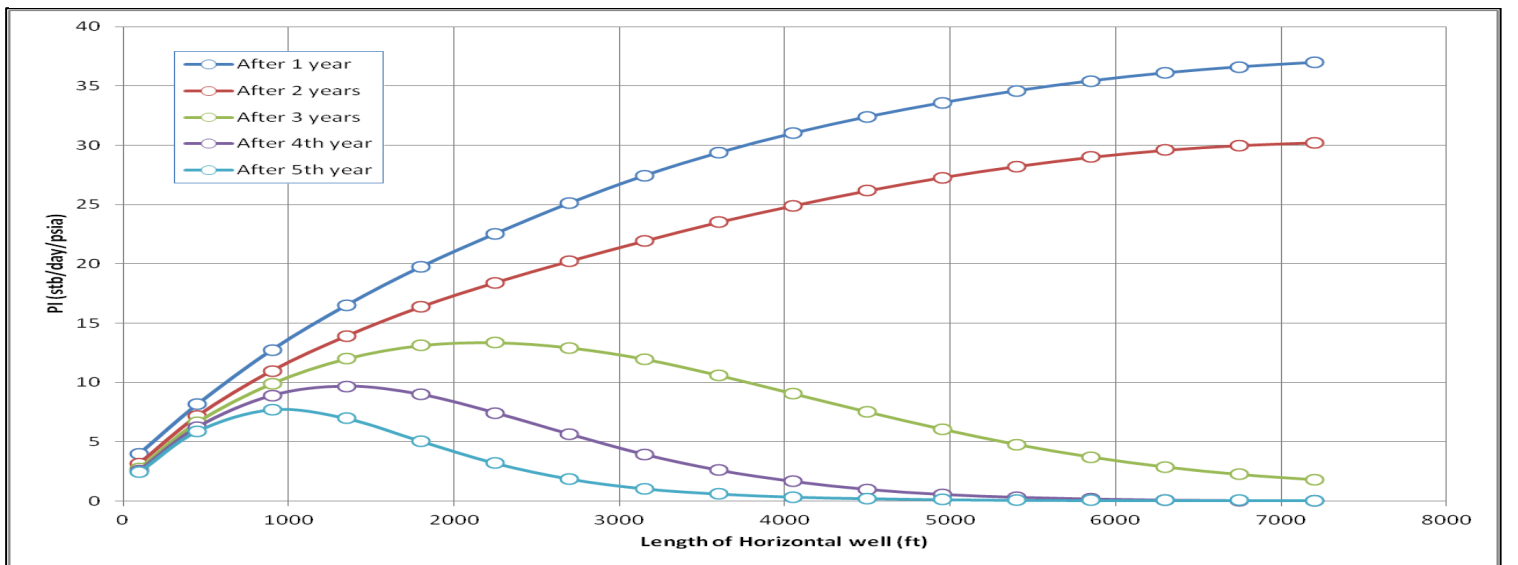

Fig4.6 Productivity Index v/s Horizontal Well Length for Case-1(b)

### 4.3 Case-1 (c)

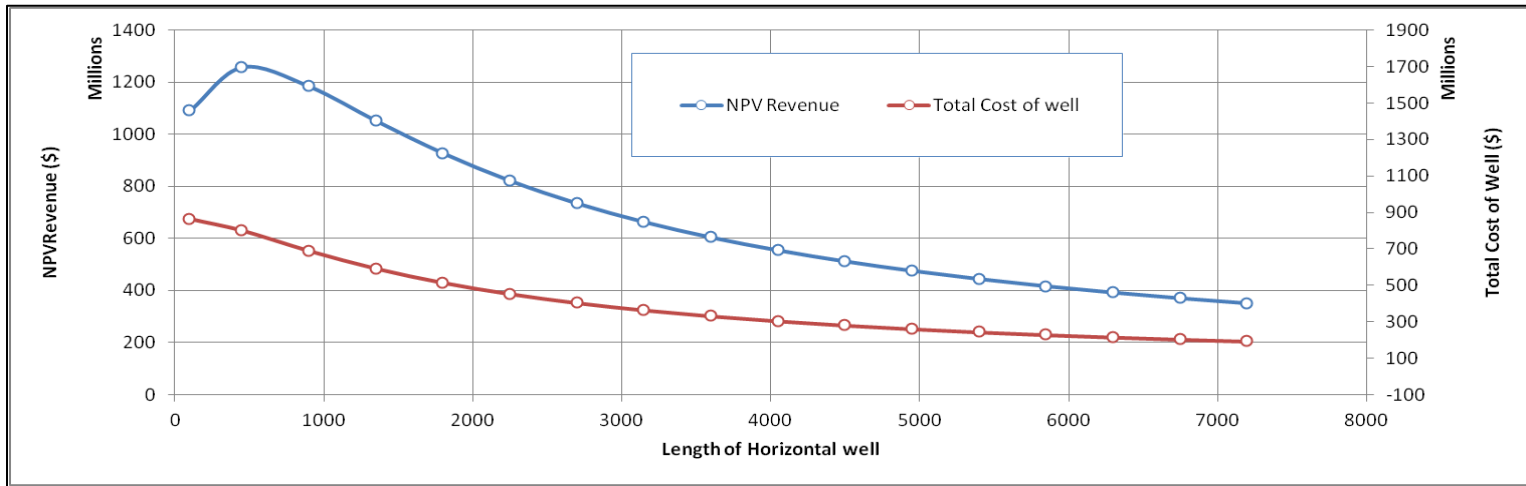

Fig 4.7 NPV and Total Cost v/s Horizontal Well Length for Case-1(c)

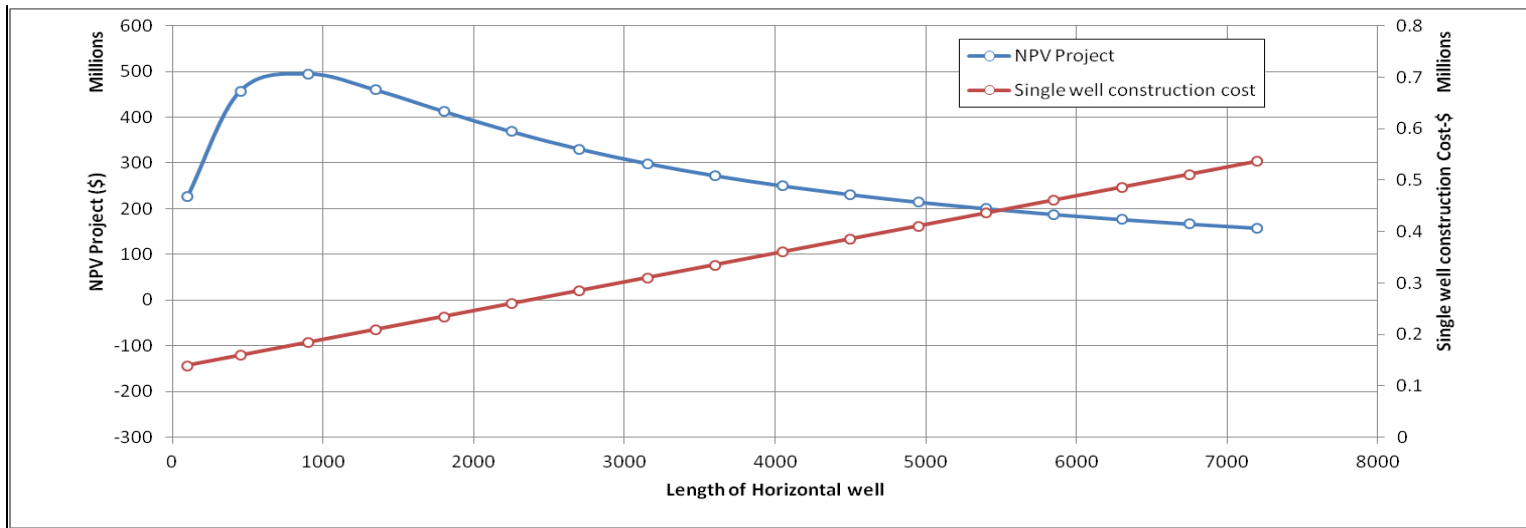

Fig4.8 NPV project and Single Well Construction Cost v/s Horizontal Well Length for Case-1(c)

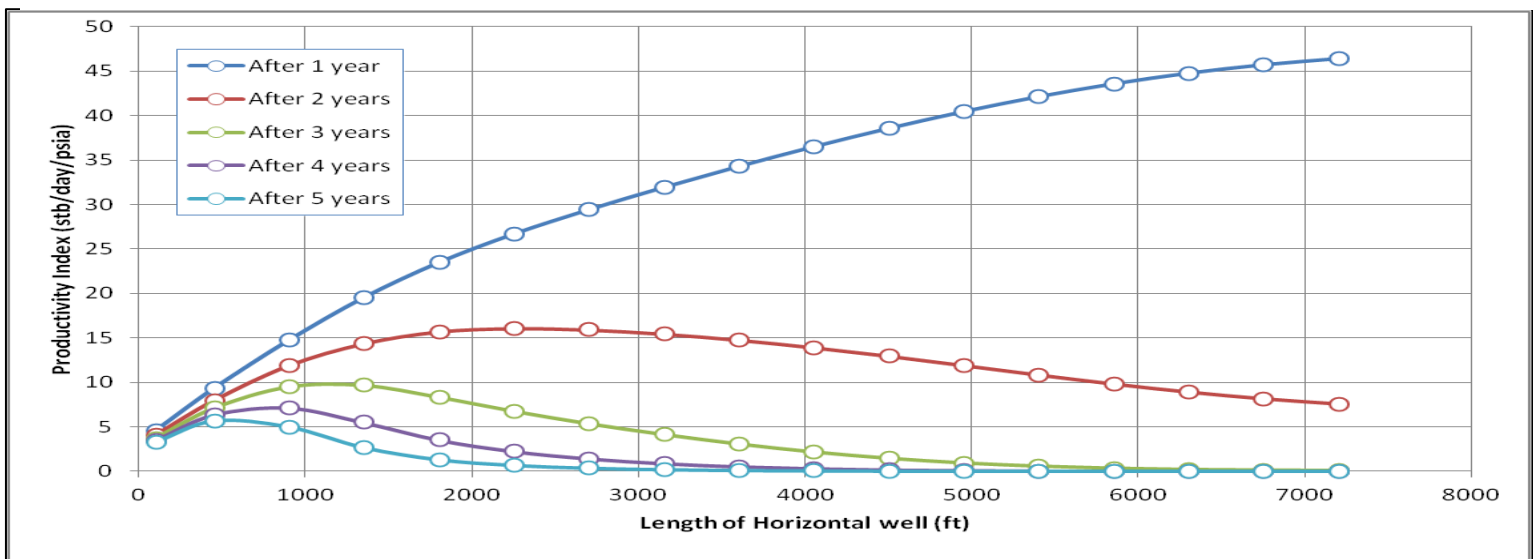

Fig4.9 Productivity Index v/s Horizontal Well Length for Case-1(c)



#### 4.4 Case-2 (a)

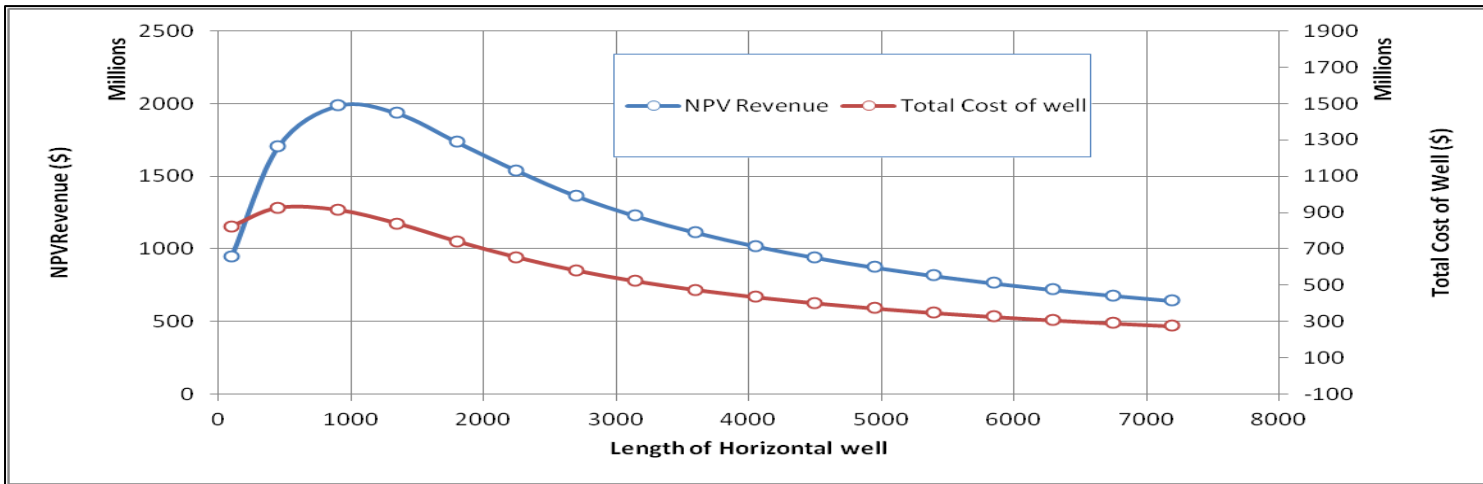

Fig 4.10 NPV and Total Cost v/s Horizontal Well Length for Case-2(a)

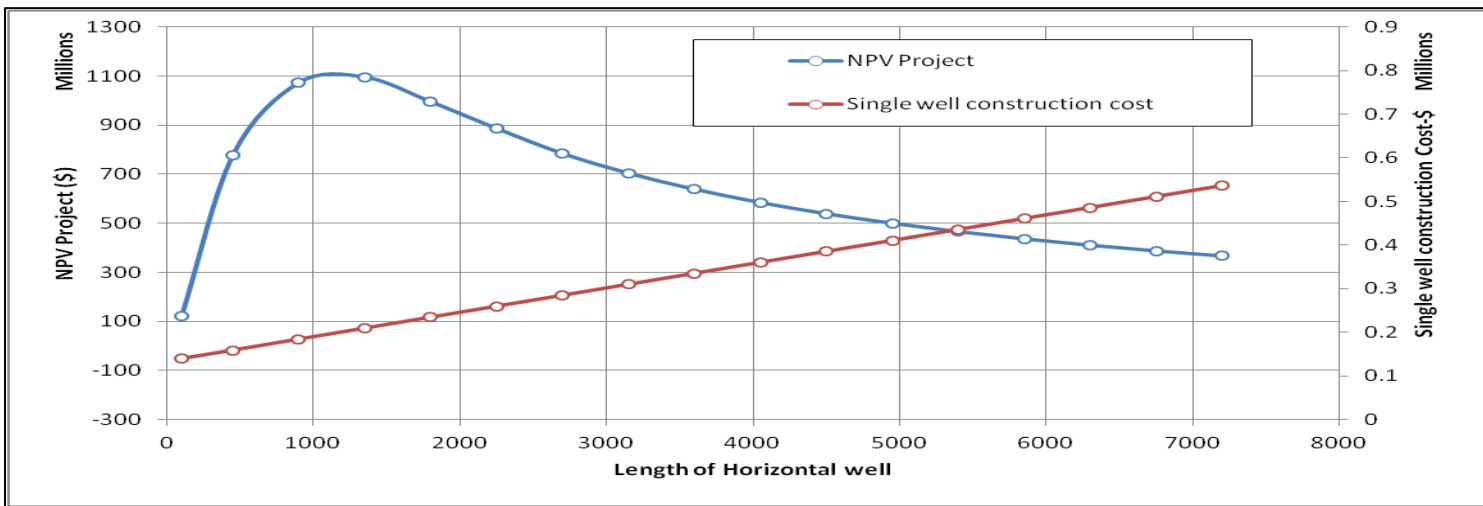

Fig4.11 NPV project and Single Well Construction Cost v/s Horizontal Well Length for Case-2(a)

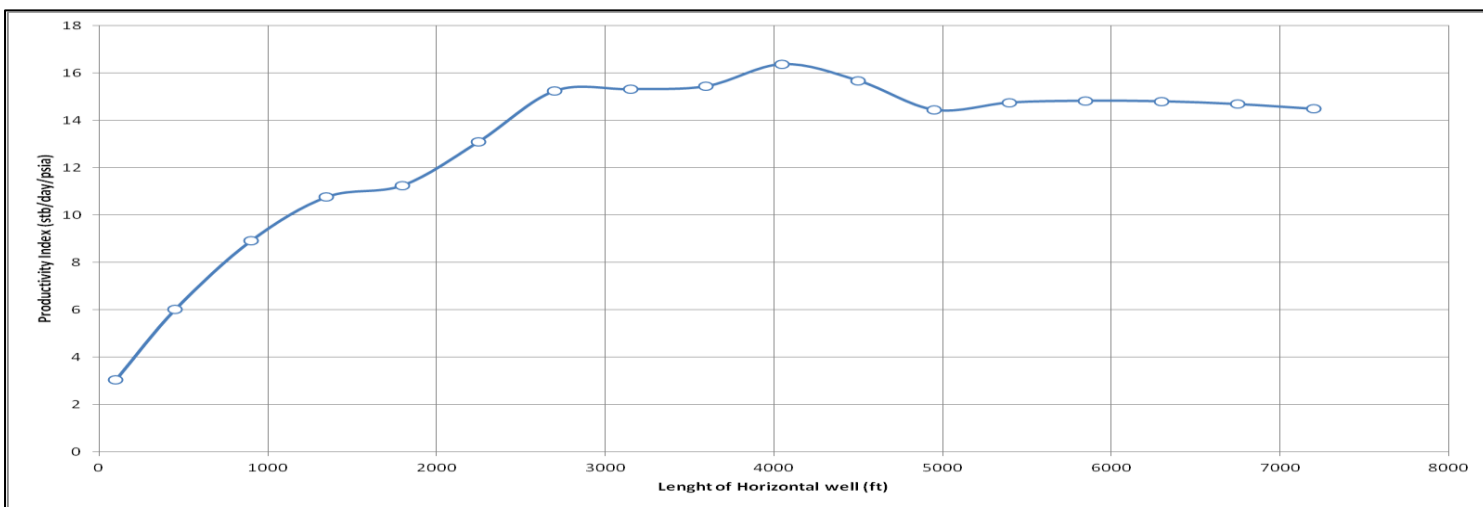

Fig4.12 Productivity Index v/s Horizontal Well Length for Case-2(a)

### 4.5 Case-2 (b)

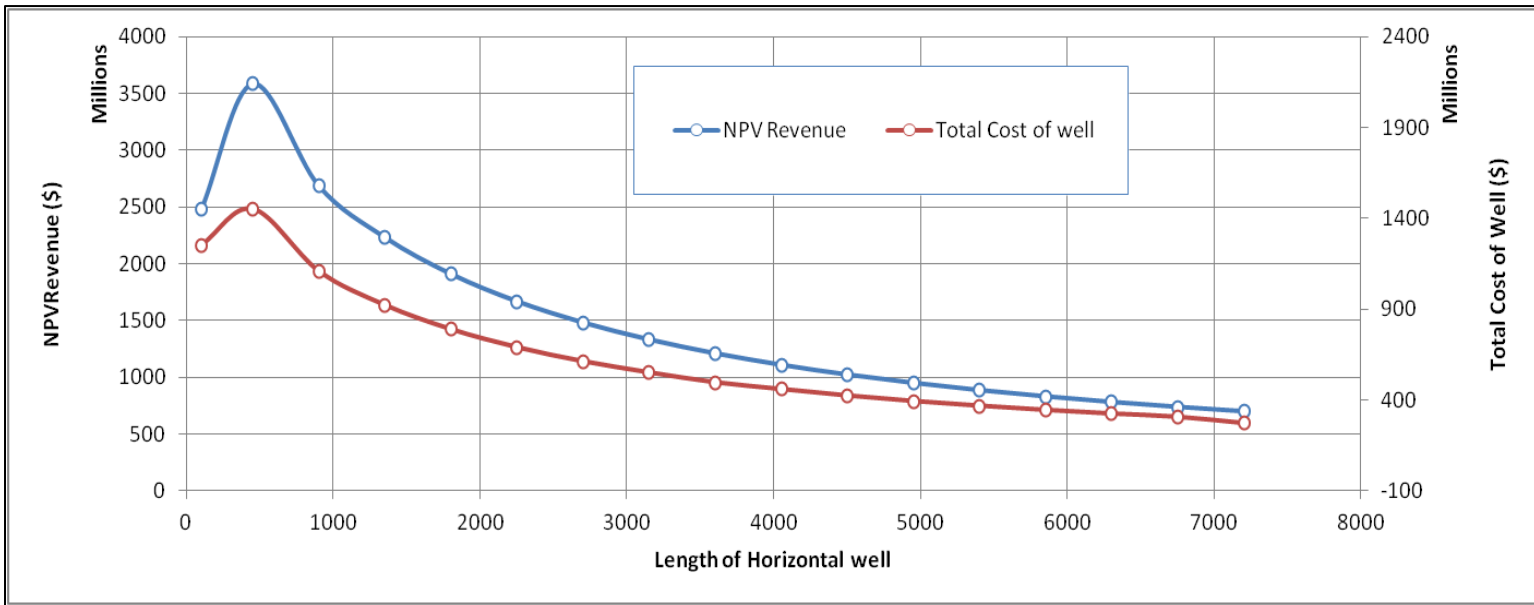

Fig 4.13 NPV and Total Cost v/s Horizontal Well Length for Case-2(b)

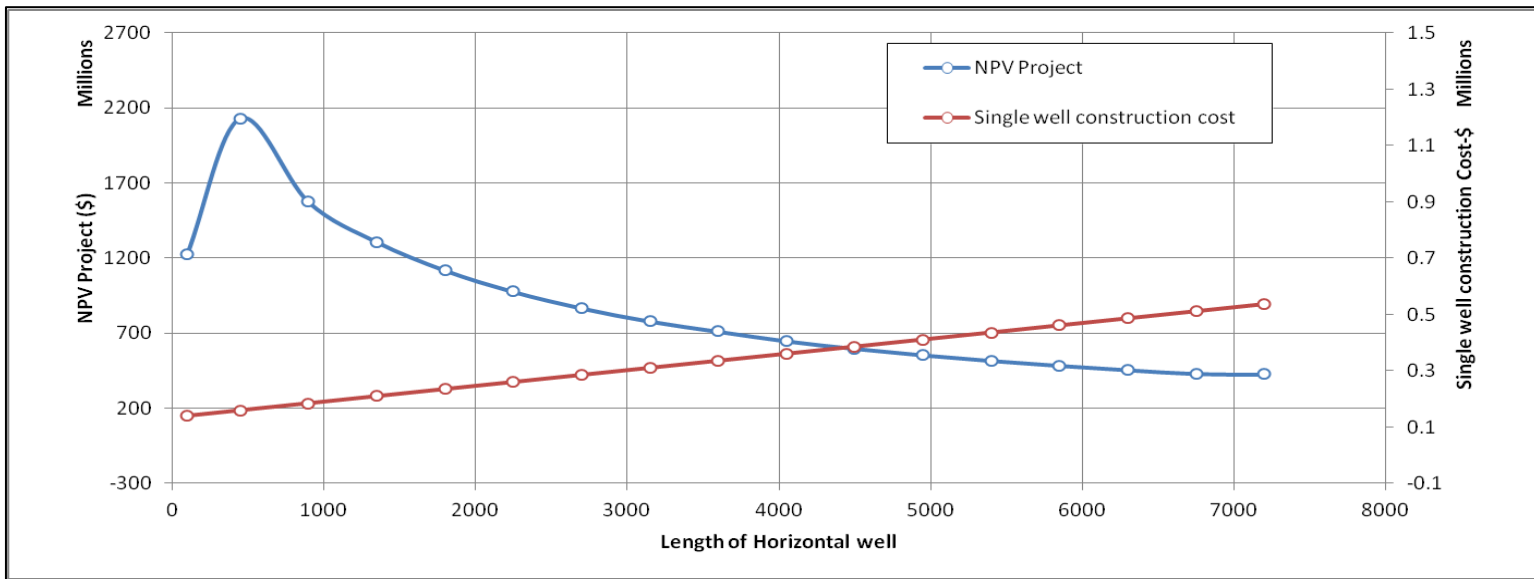

Fig4.14 NPV project and Single Well Construction Cost v/s Horizontal Well Length for Case-2(b)

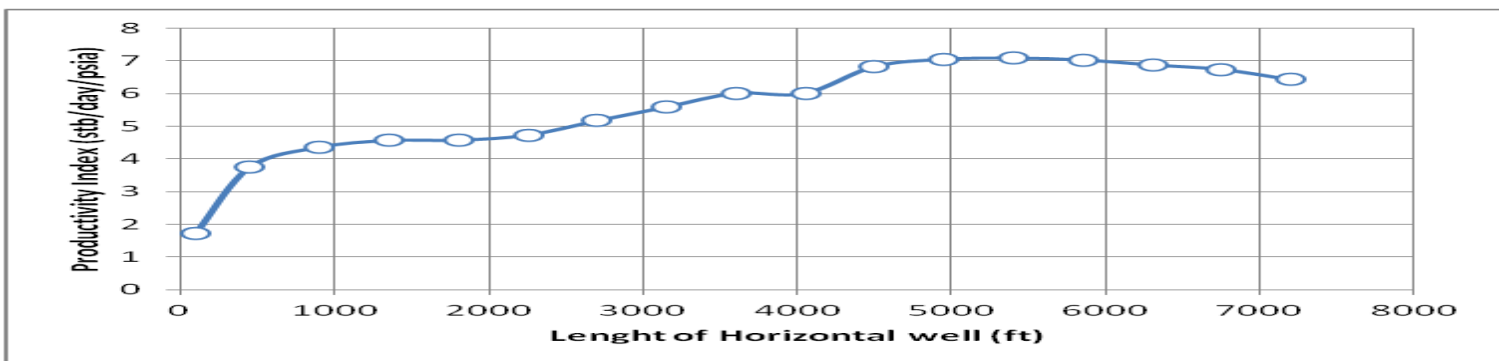

Fig4.15 Productivity Index v/s Horizontal Well Length for Case-3(a)

### 4.6 Case-2 (c)

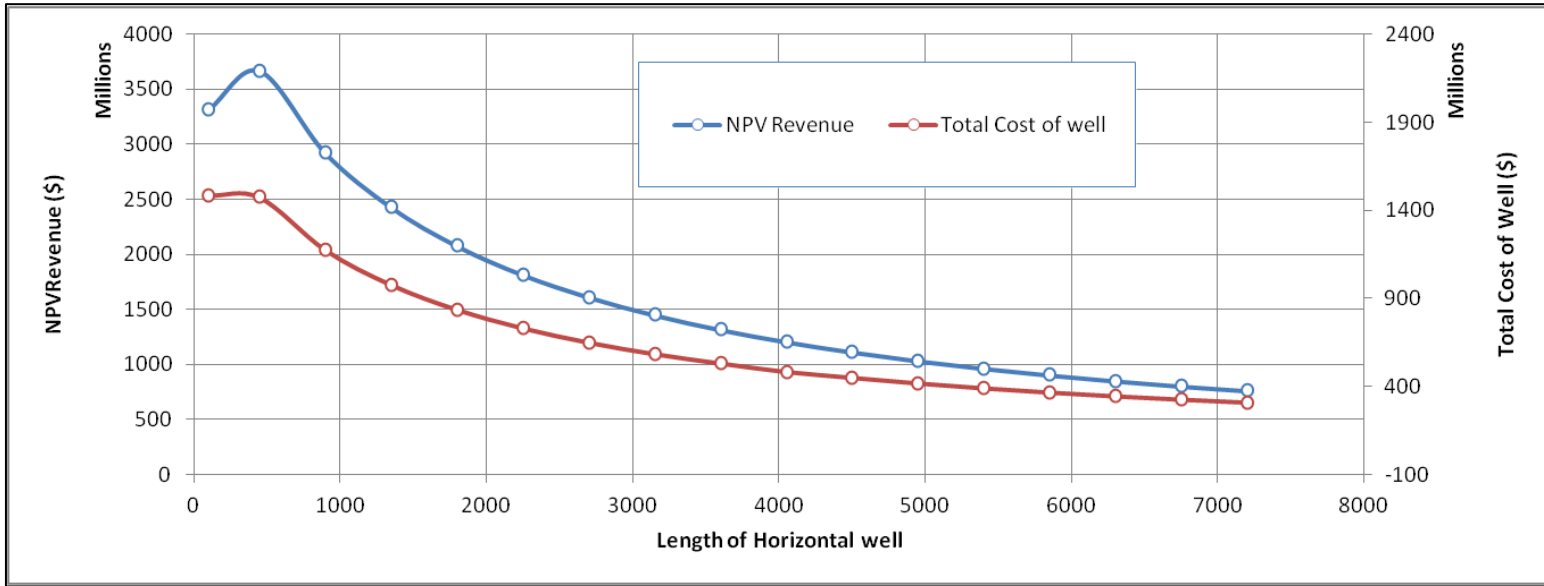

Fig 4.16 NPV and Total Cost v/s Horizontal Well Length for Case-2(c)

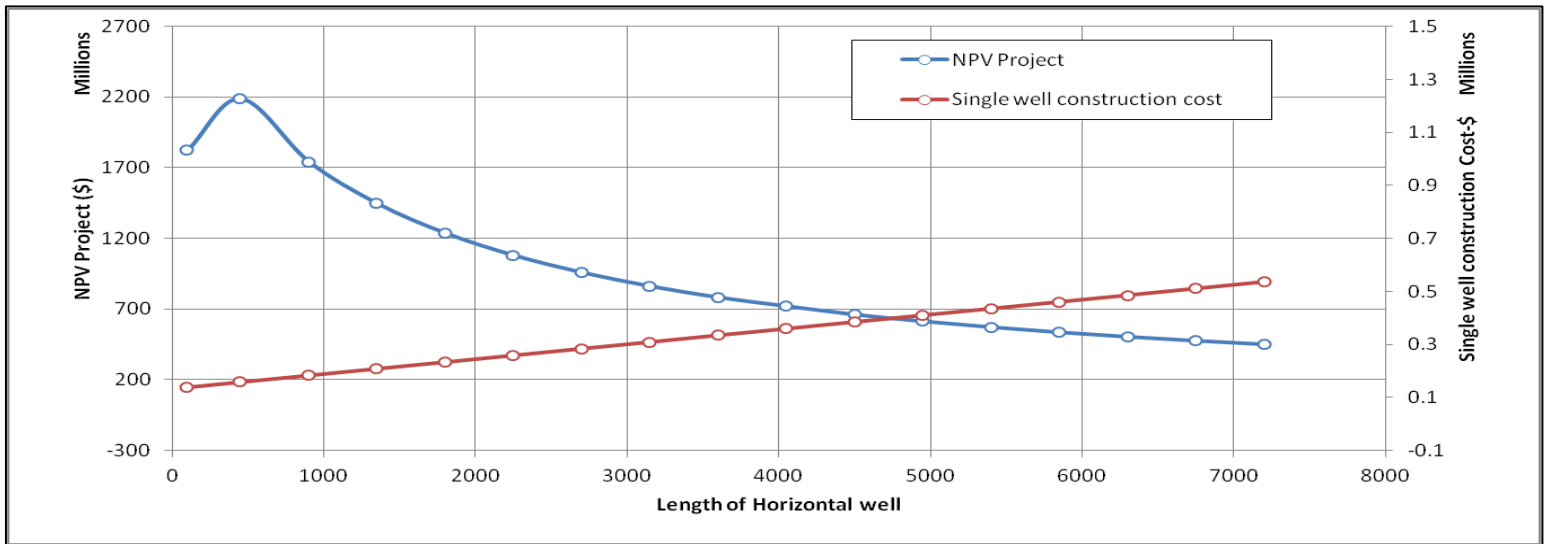

Fig4.17 NPV project and Single Well Construction Cost v/s Horizontal Well Length for Case-2(c)

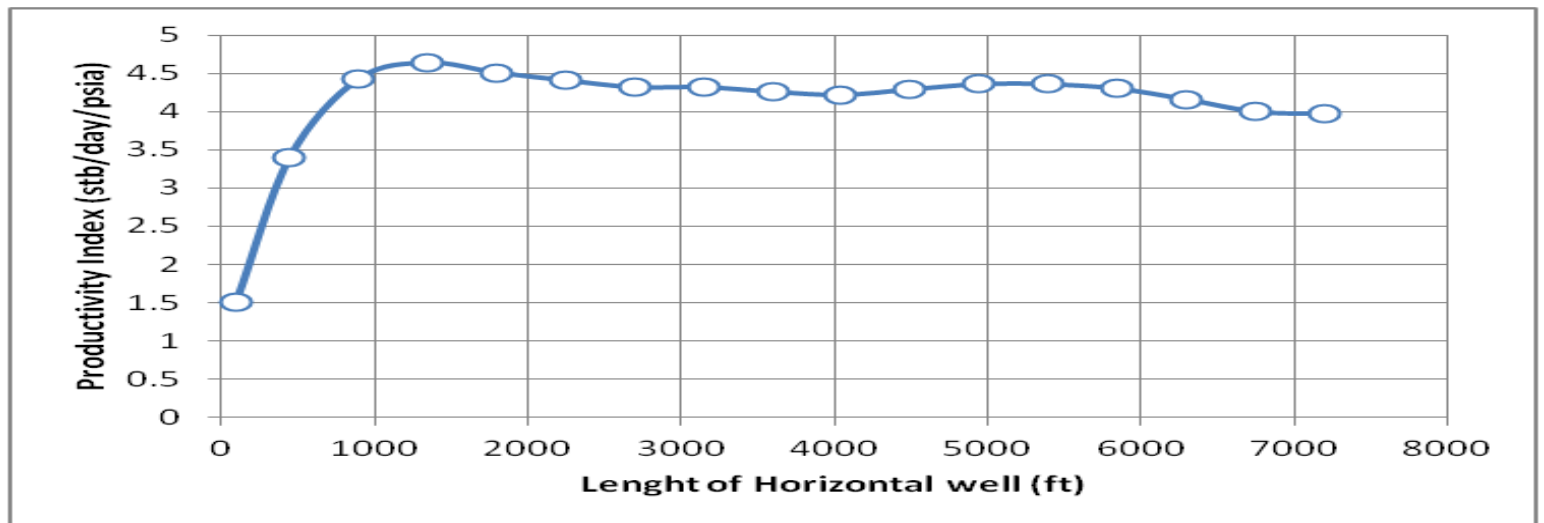

Fig4.18 Productivity Index v/s Horizontal Well Length for Case-2(c)

### 4.7 Case-3(a)

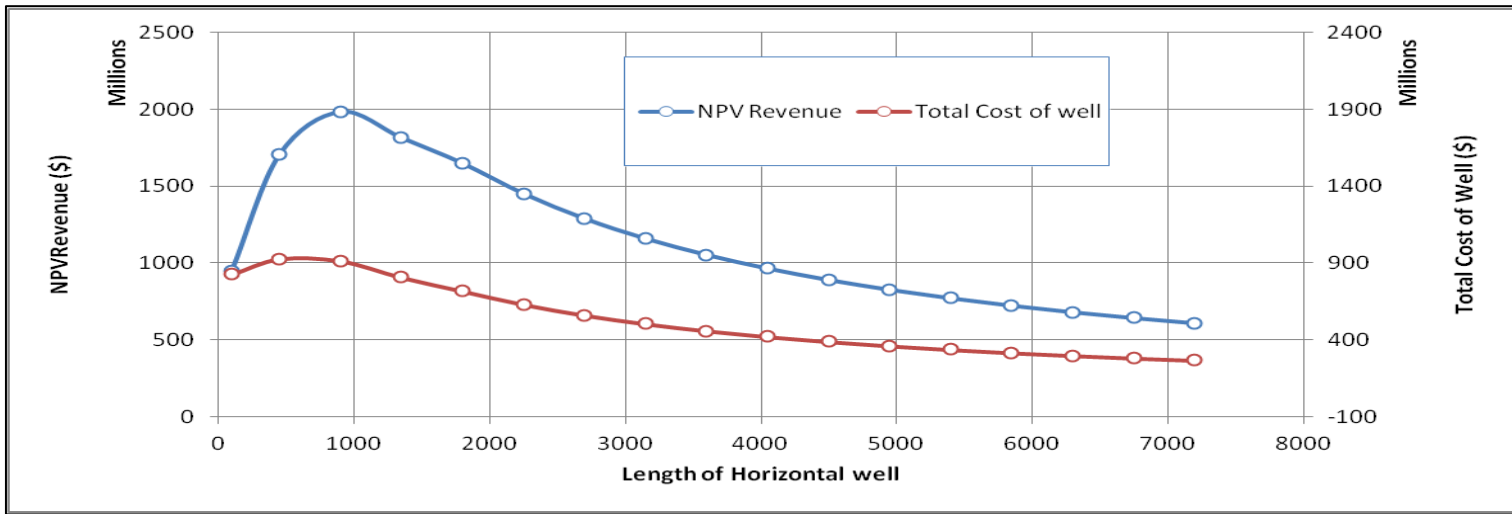

Fig 4.19 NPV and Total Cost v/s Horizontal Well Length for Case-3(a)

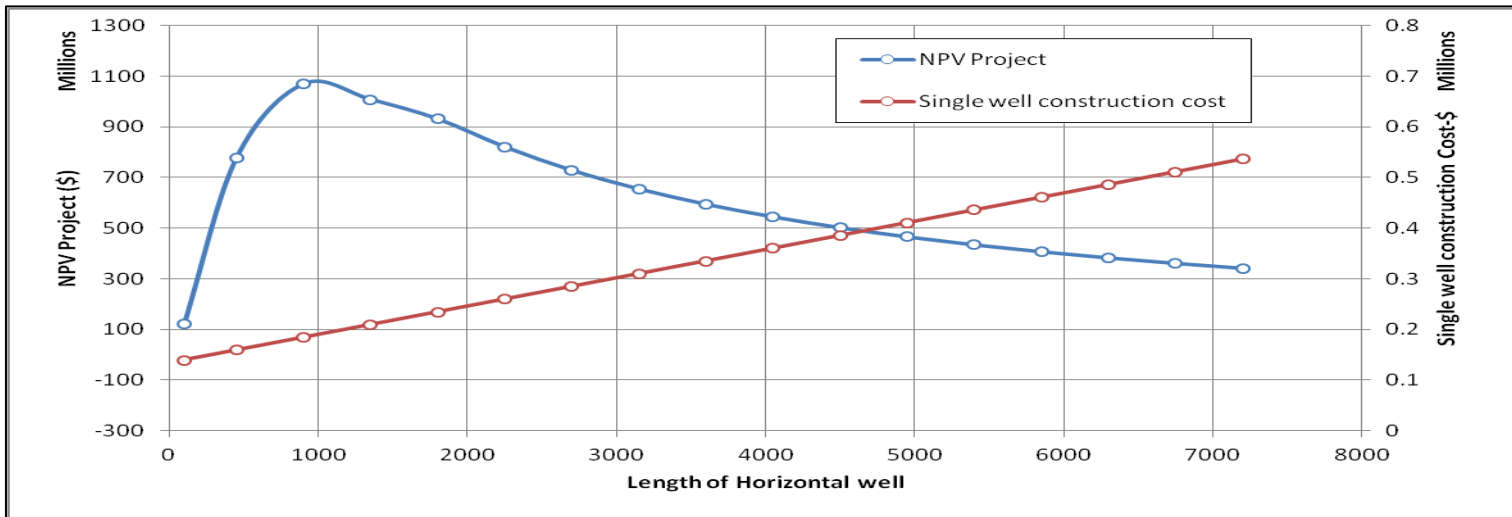

Fig4.20 NPV project and Single Well Construction Cost v/s Horizontal Well Length for Case-3(a)

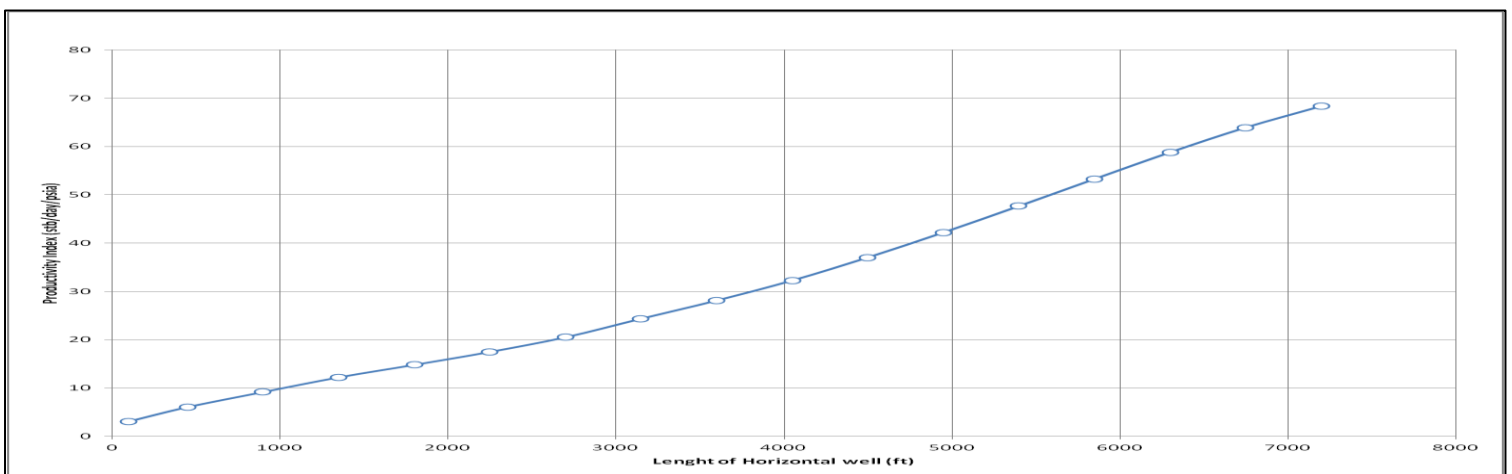

Fig4.21 Productivity Index v/s Horizontal Well Length for Case-3(a)

### 4.8 Case-3 (b)

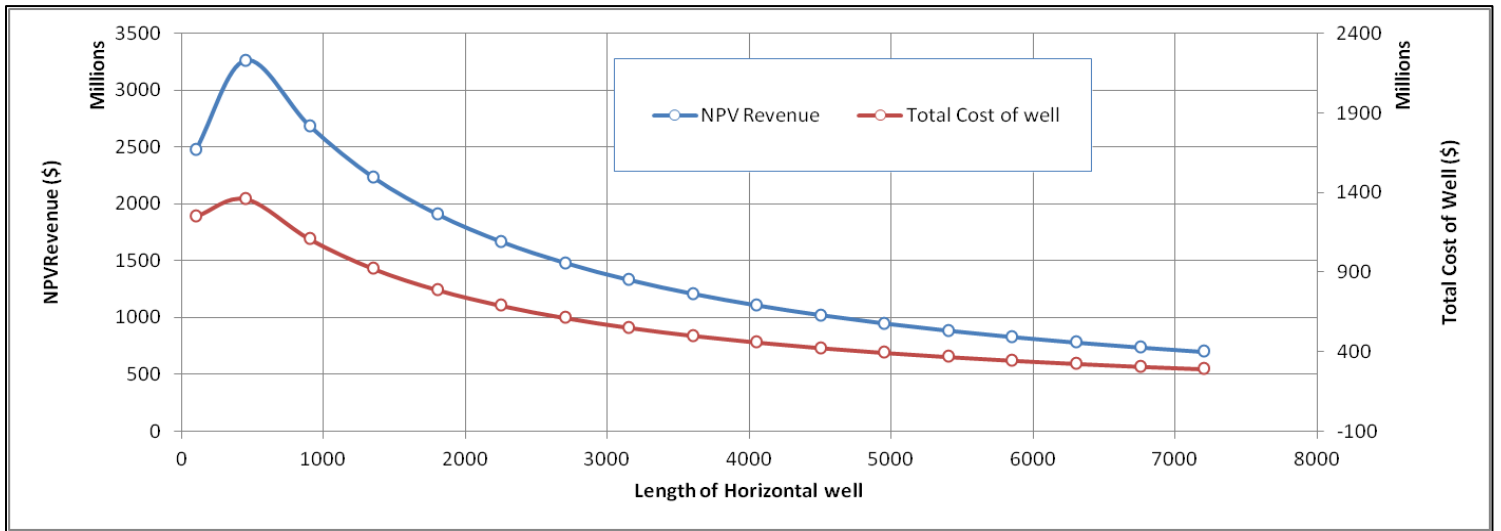

Fig 4.22 NPV and Total Cost v/s Horizontal Well Length for Case-3(b)

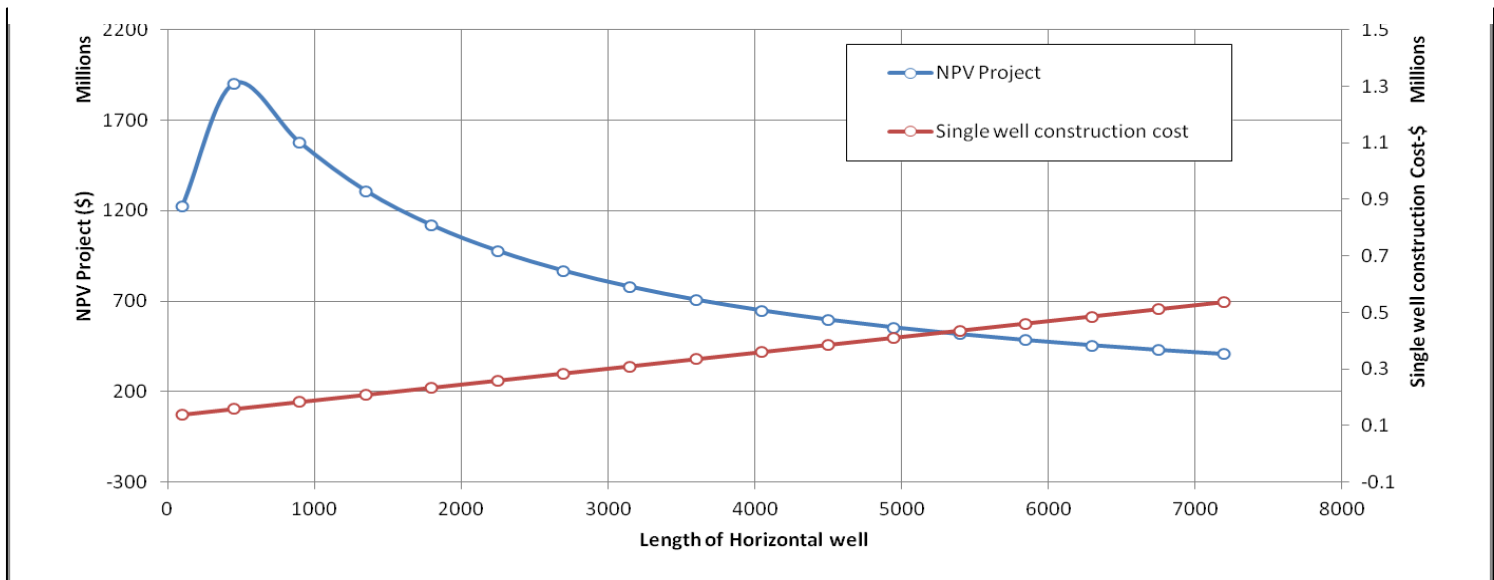

Fig4.23 NPV project and Single Well Construction Cost v/s Horizontal Well Length for Case-3(b)

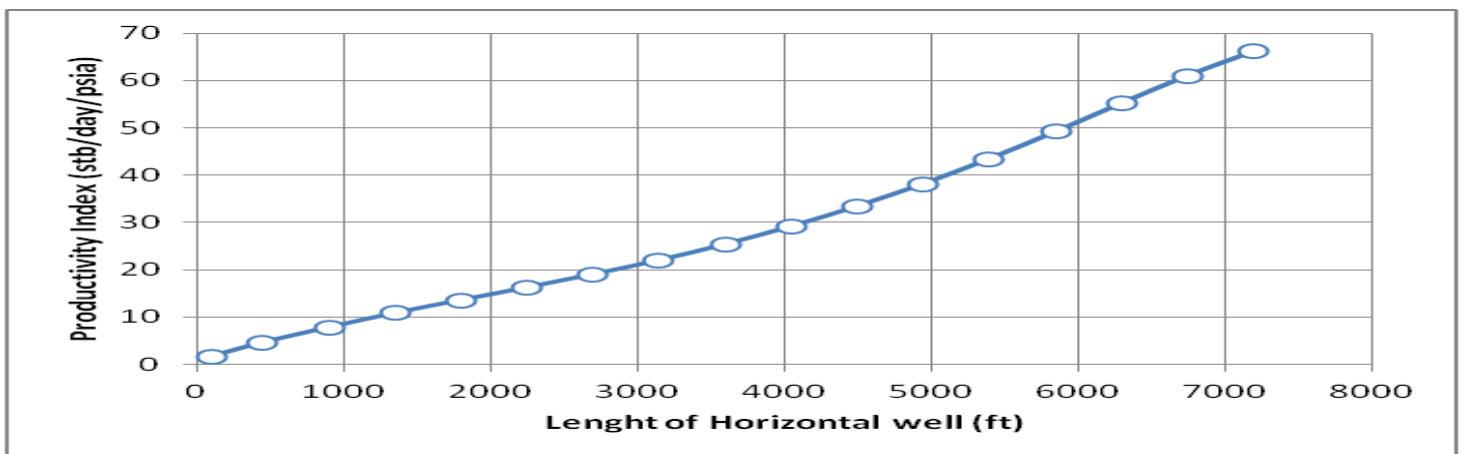

Fig4.24 Productivity Index v/s Horizontal Well Length for Case-3(b)

### 4.9 Case-3(c)

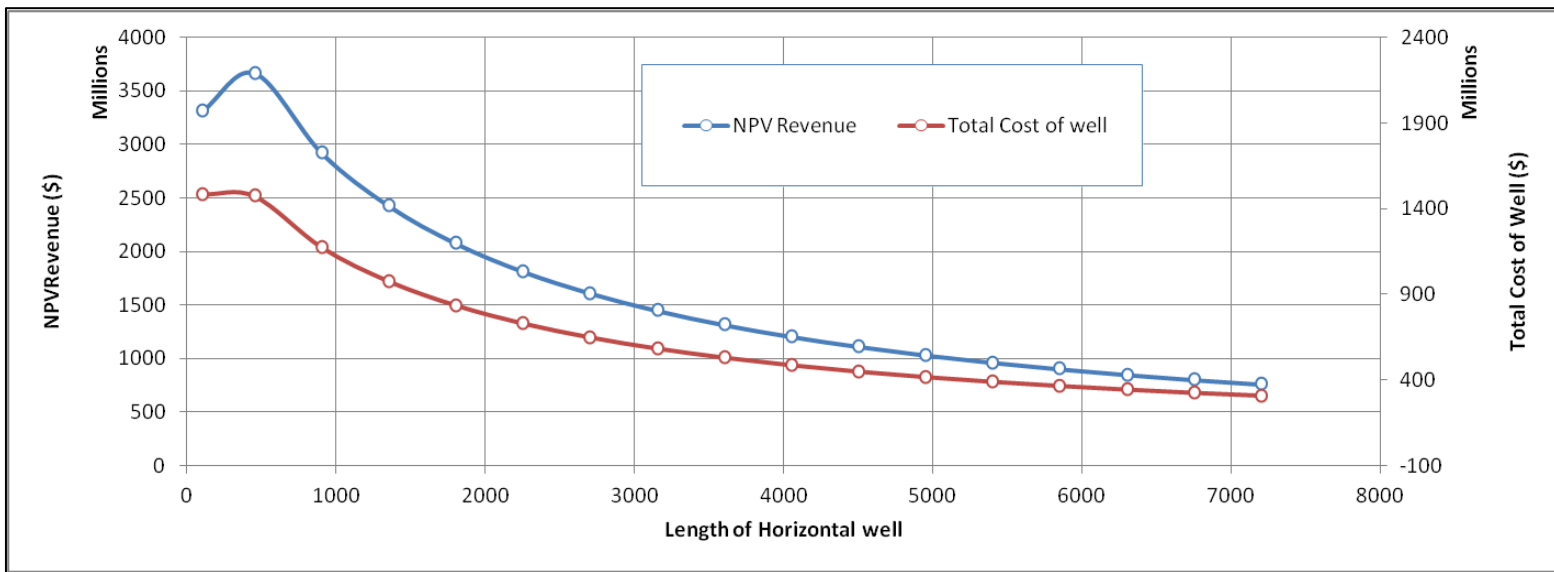

Fig 4.25 NPV and Total Cost v/s Horizontal Well Length for Case-3(c)

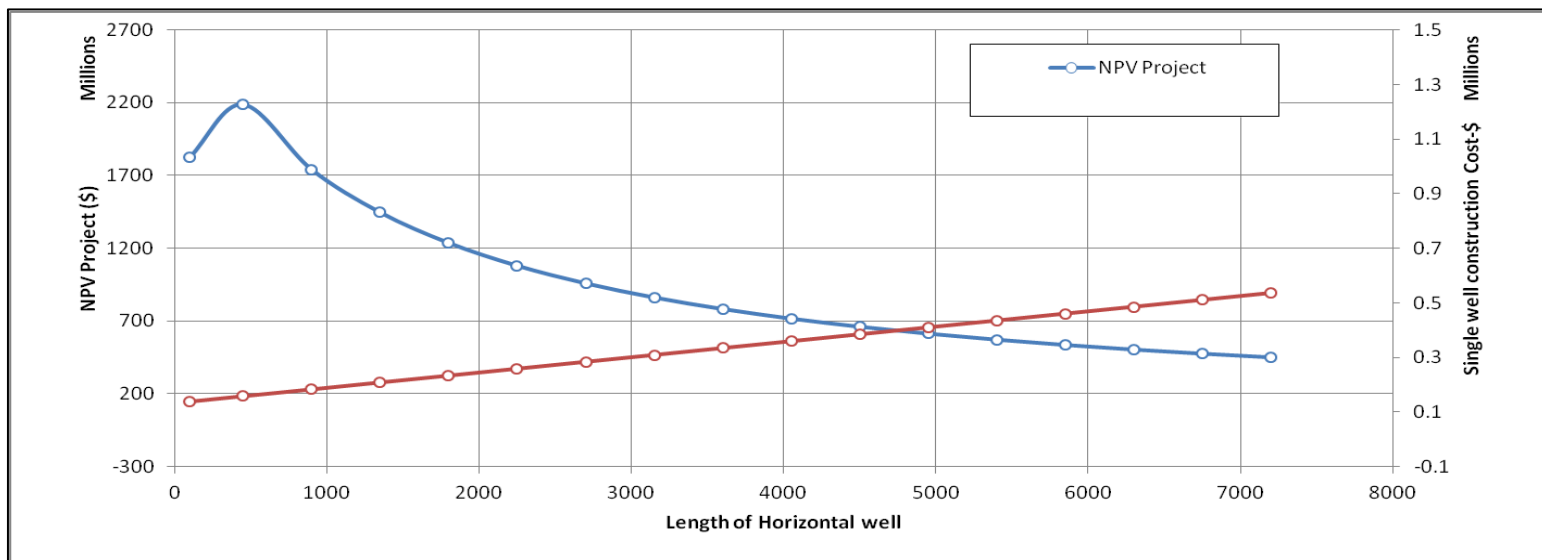

Fig4.26 NPV project and Single Well Construction Cost v/s Horizontal Well Length for Case-3(c)

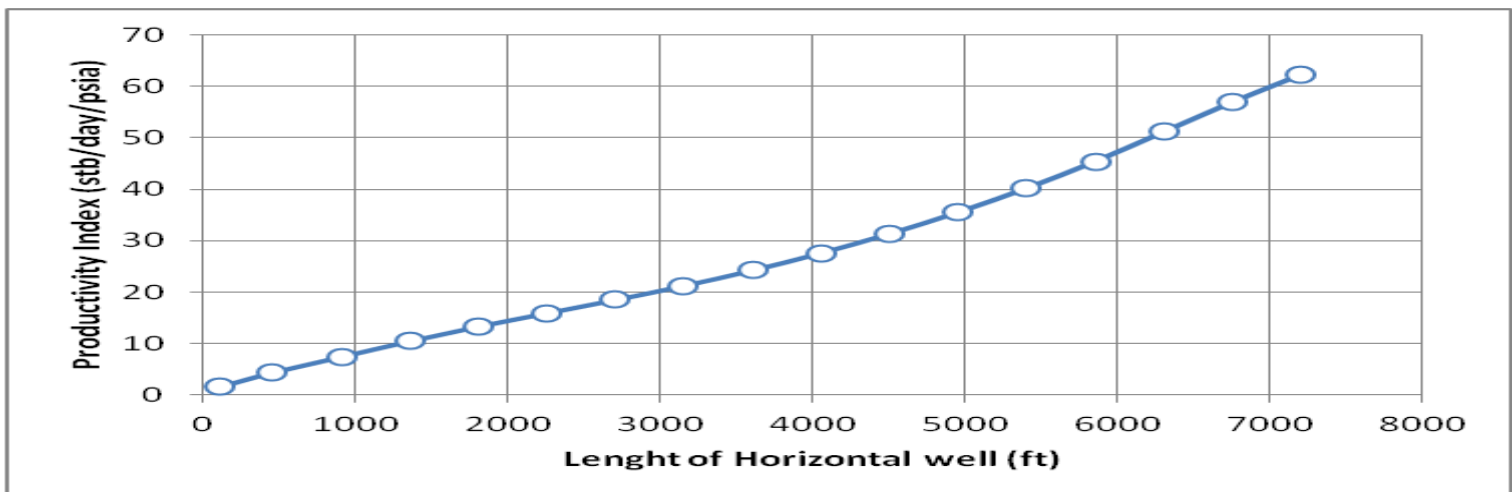

Fig4.27 Productivity Index v/s Horizontal Well Length for Case-3(c)

### 4.10 Case-4 (a)

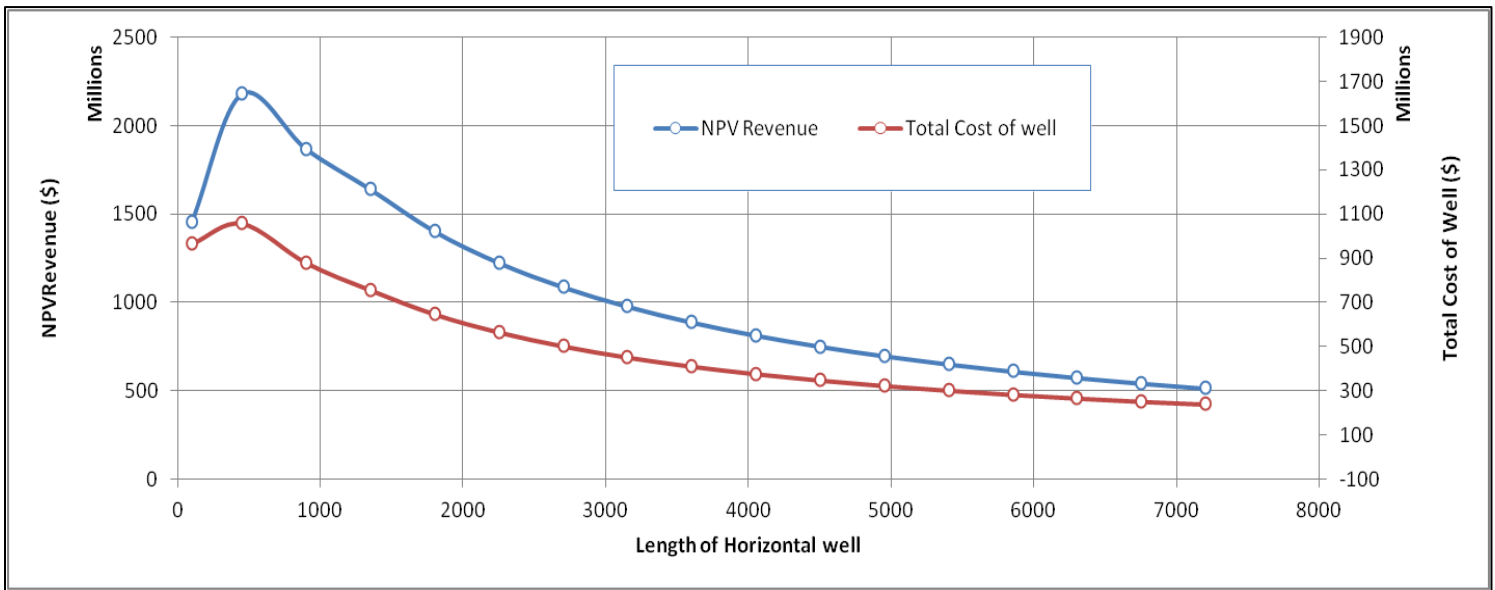

Fig 4.28 NPV and Total Cost v/s Horizontal Well Length for Case-4(a)

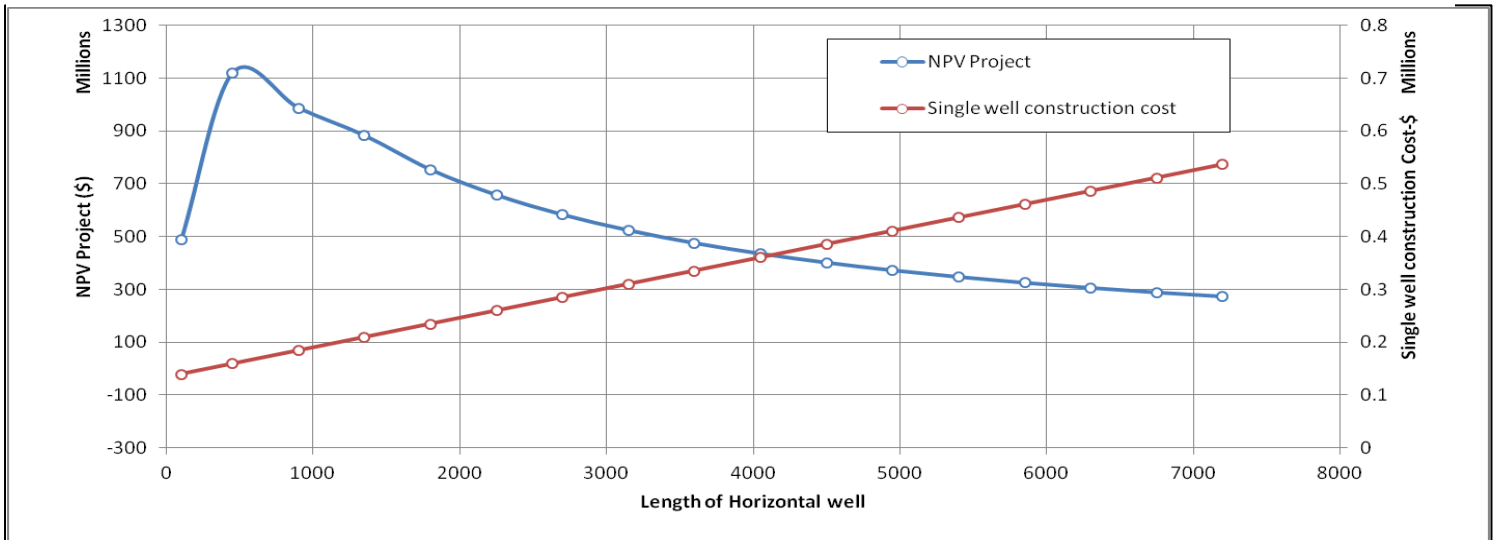

Fig4.29 NPV project and Single Well Construction Cost v/s Horizontal Well Length for Case-4(a)

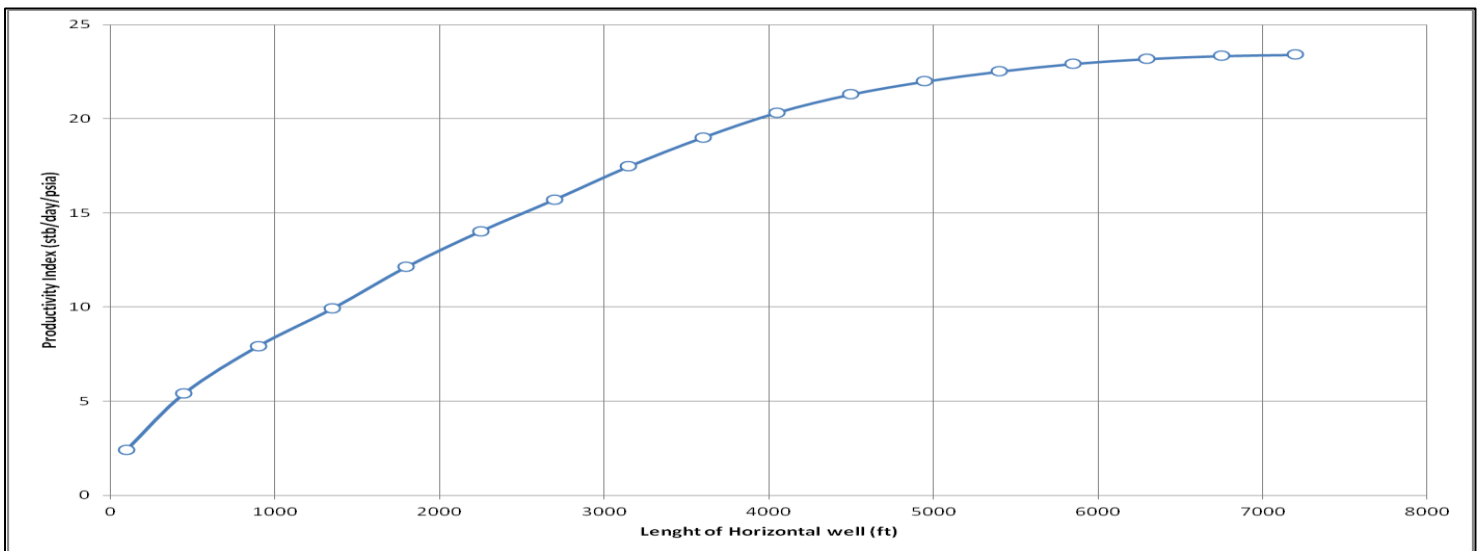

Fig4.30 Productivity Index v/s Horizontal Well Length for Case-4(a)

### 4.11 Case-4 (b)

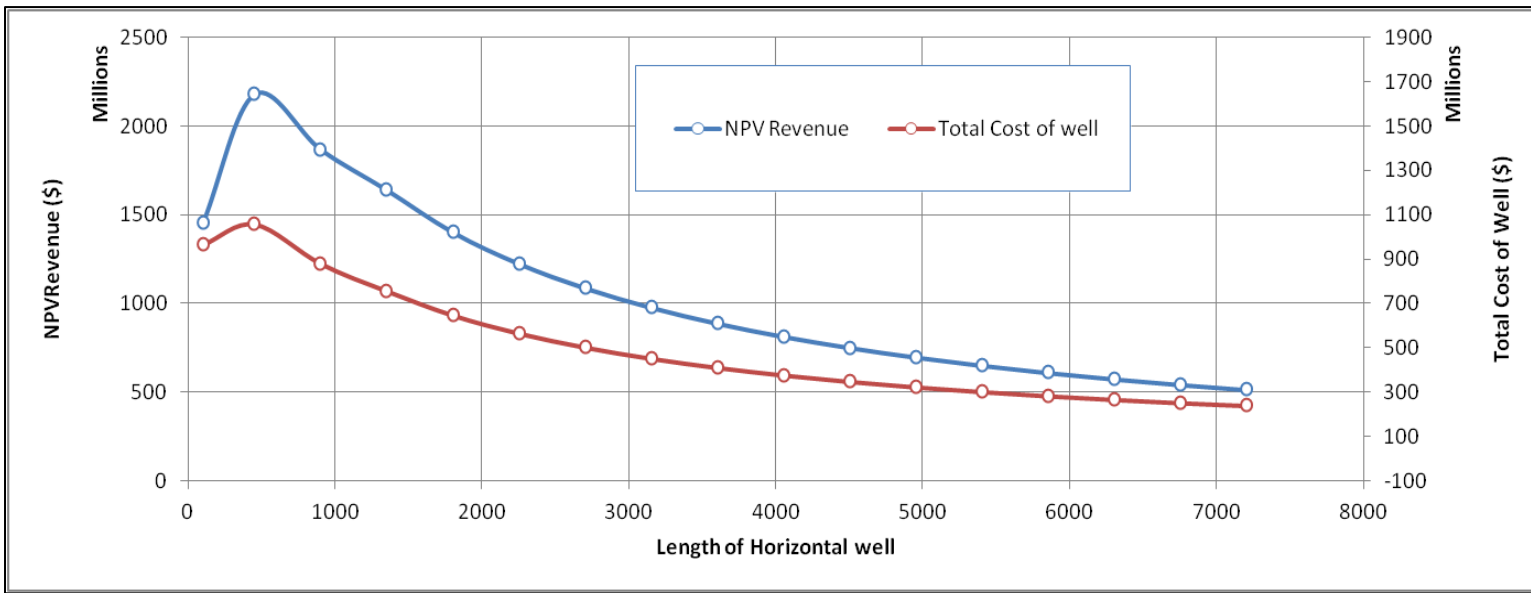

Fig 4.31 NPV and Total Cost v/s Horizontal Well Length for Case-4(b)

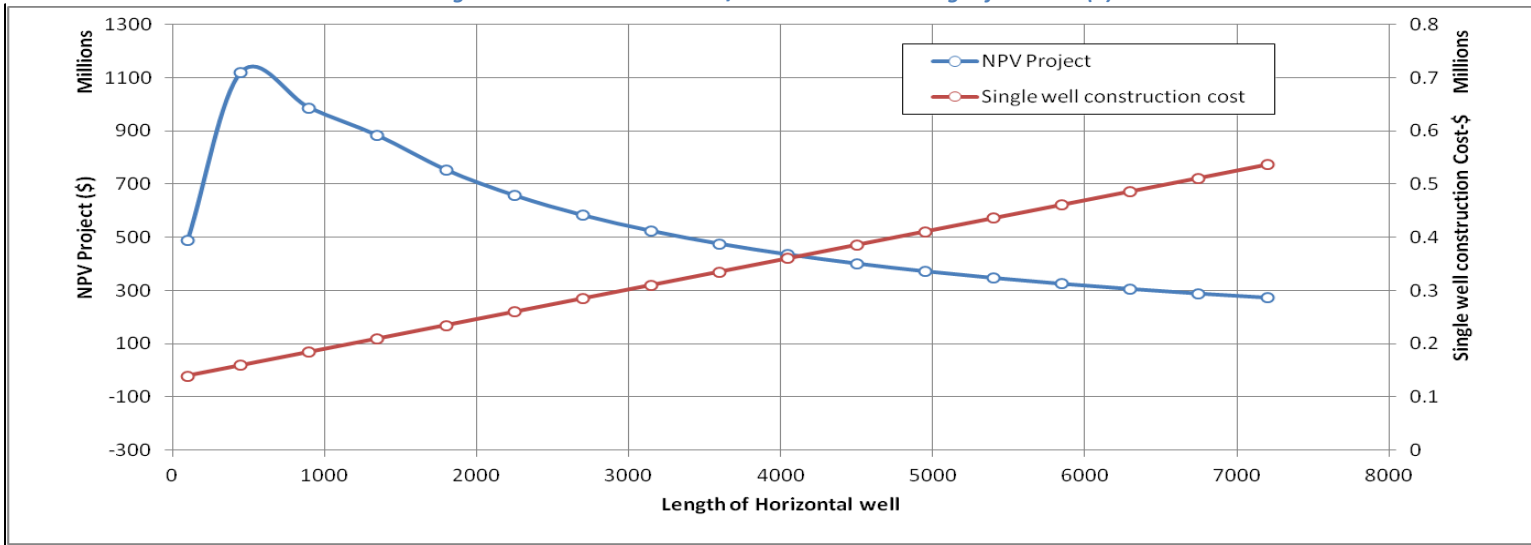

Fig4.32 NPV project and Single Well Construction Cost v/s Horizontal Well Length for Case-4(b)

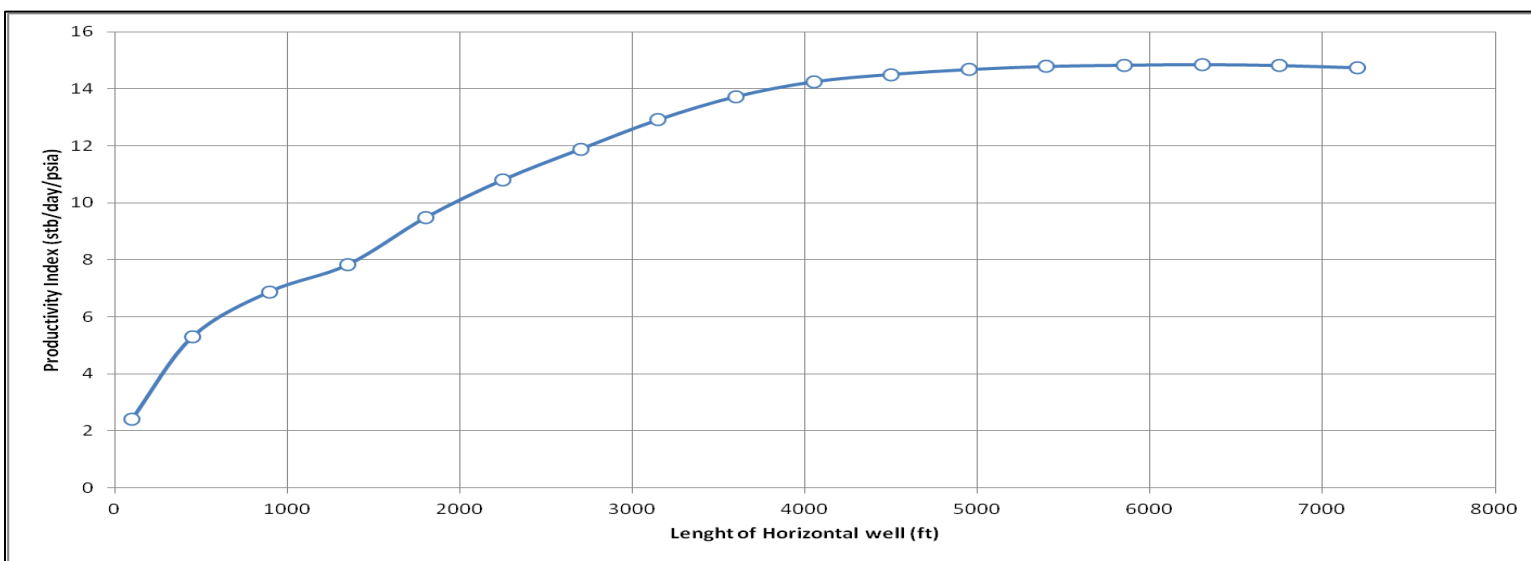

Fig4.33 Productivity Index v/s Horizontal Well Length for Case-4(b)



### 4.12 Case-4 (c)

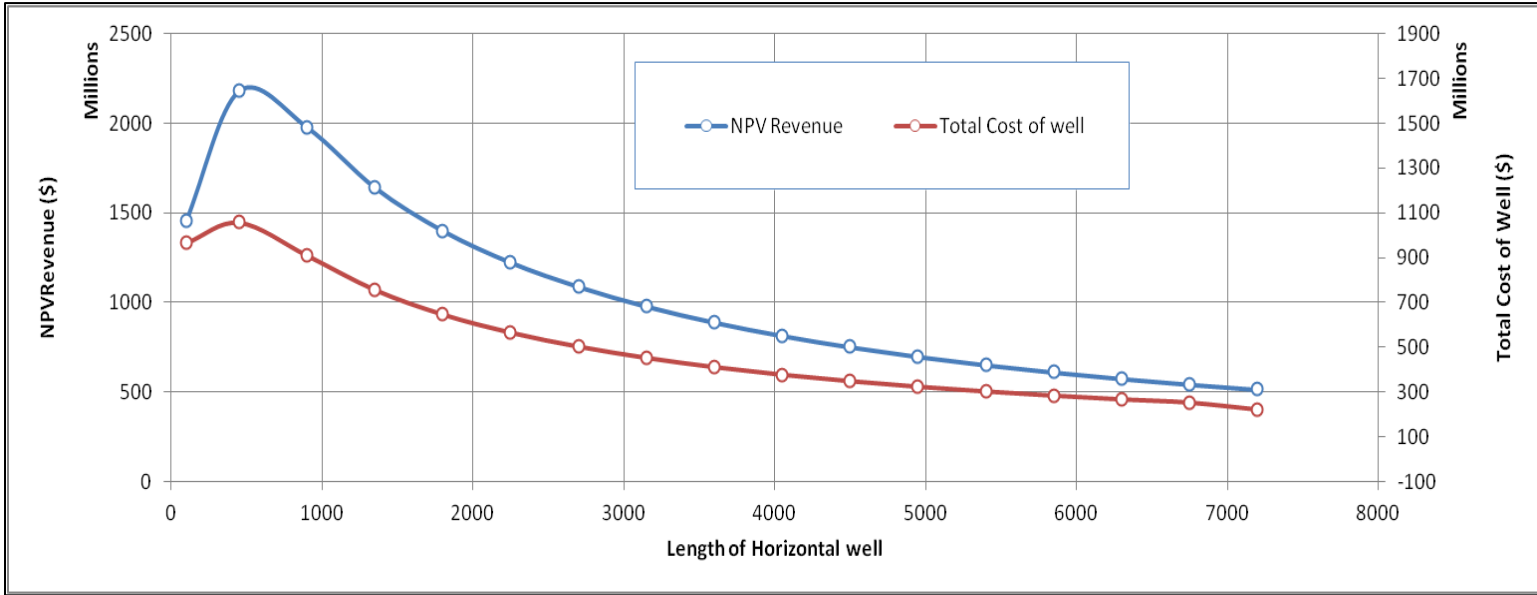

Fig 4.34 NPV and Total Cost v/s Horizontal Well Length for Case-4(c)

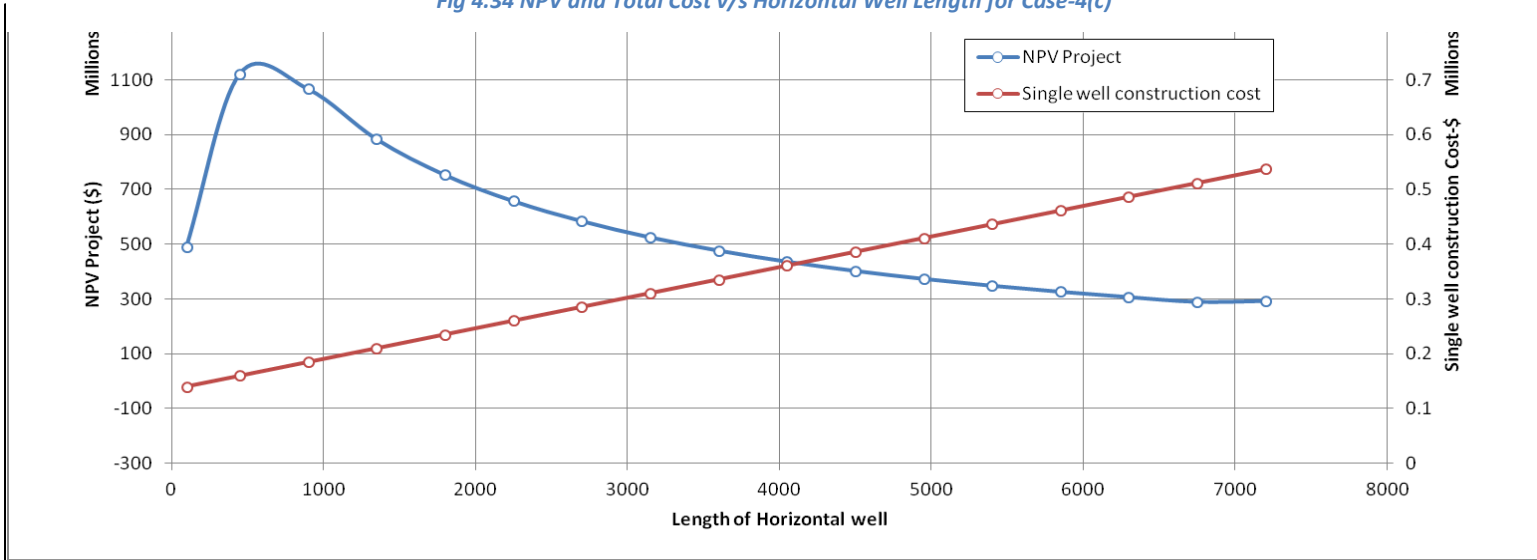

Fig4.35 NPV project and Single Well Construction Cost v/s Horizontal Well Length for Case-4(c)

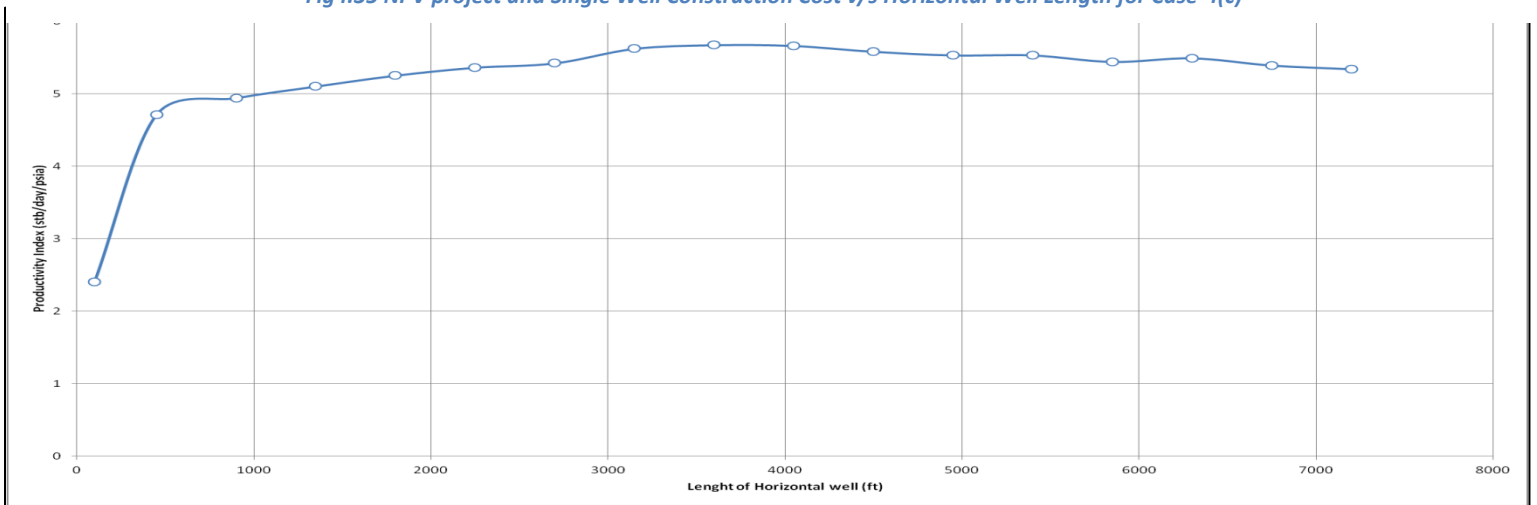

Fig4.36 Productivity Index v/s Horizontal Well Length for Case-4(c)

### 4.13 Case-5 (a)

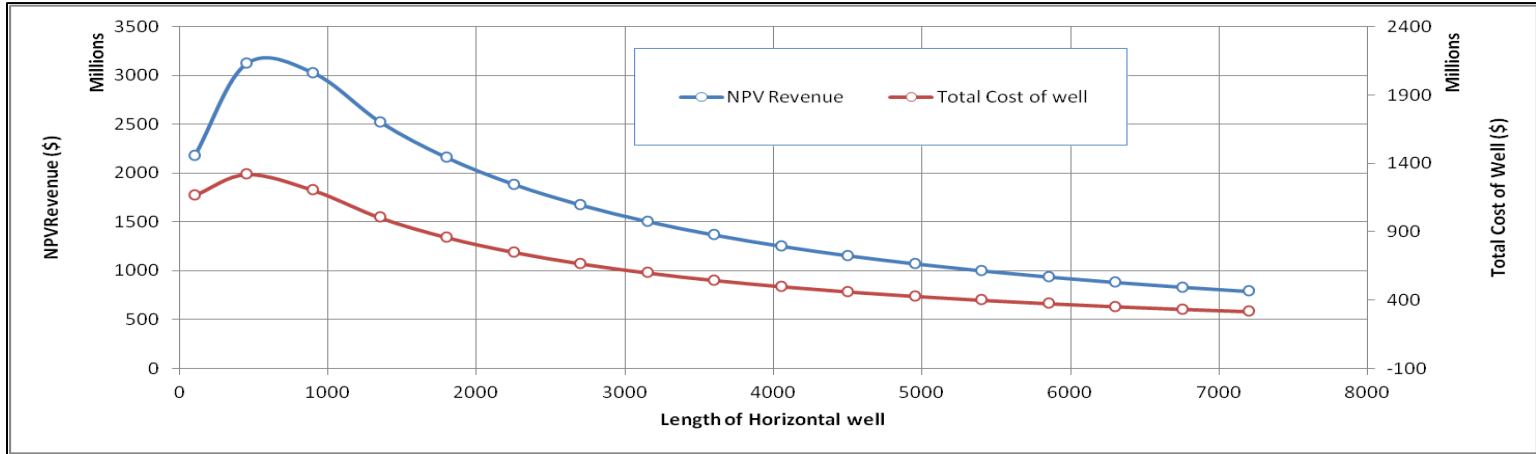

Fig 4.37 NPV and Total Cost v/s Horizontal Well Length for Case-5(a)

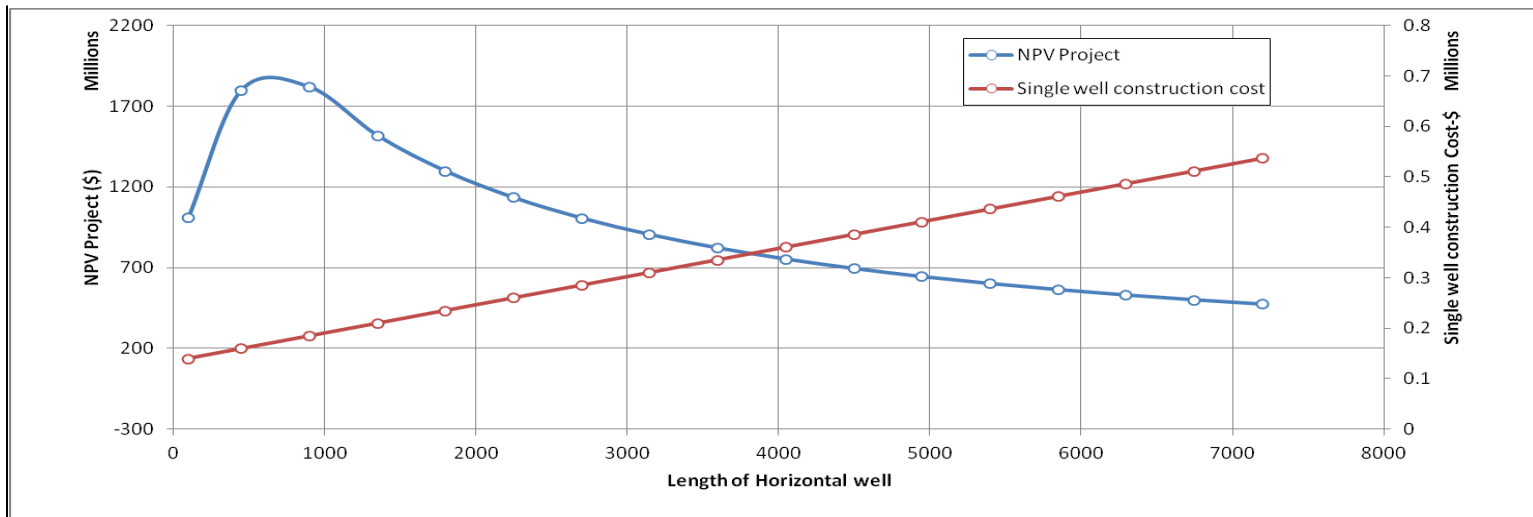

Fig4.38 NPV project and Single Well Construction Cost v/s Horizontal Well Length for Case-5(a)

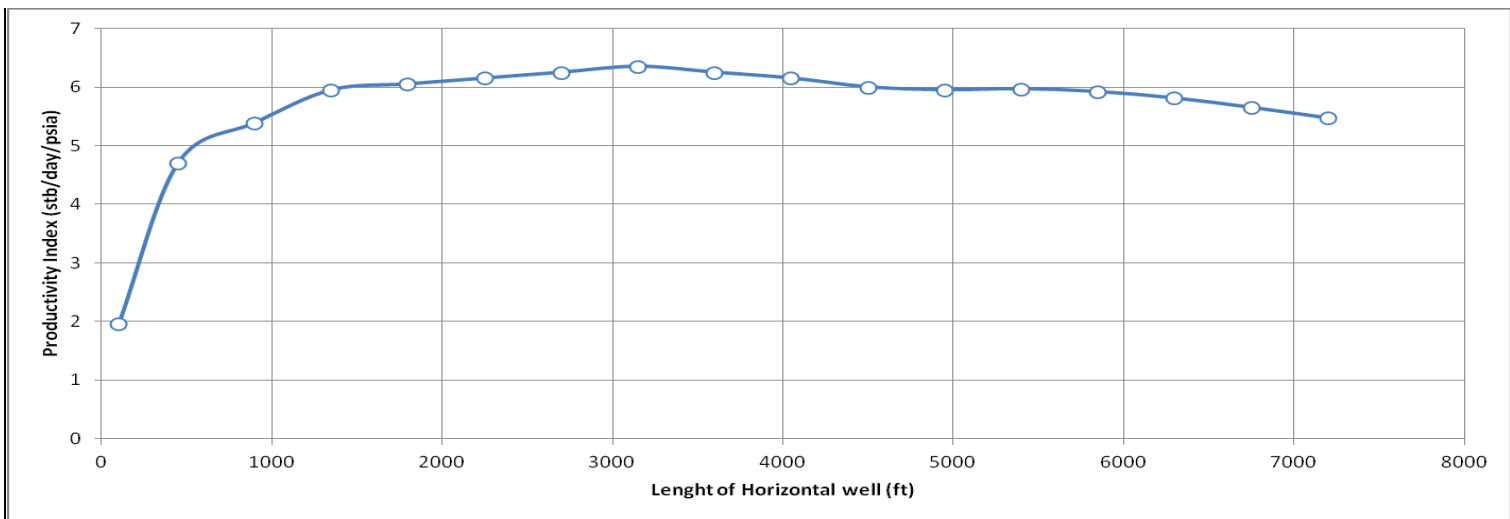

Fig4.39 Productivity Index v/s Horizontal Well Length for Case-5(a)

#### 4.14 Case-5 (b)

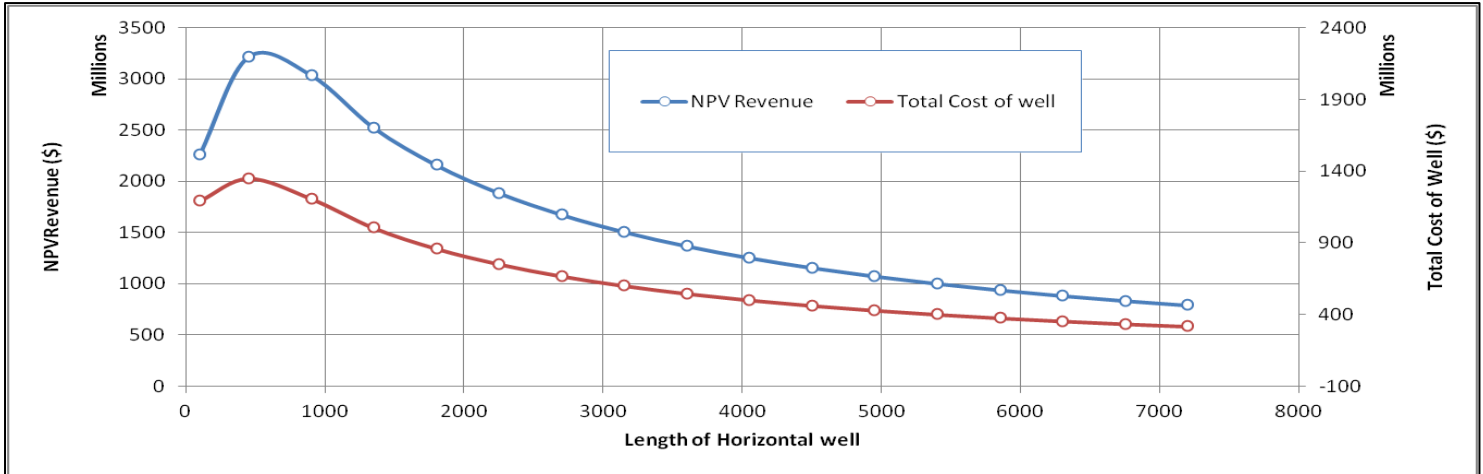

Fig 4.40 NPV and Total Cost v/s Horizontal Well Length for Case-5(b)

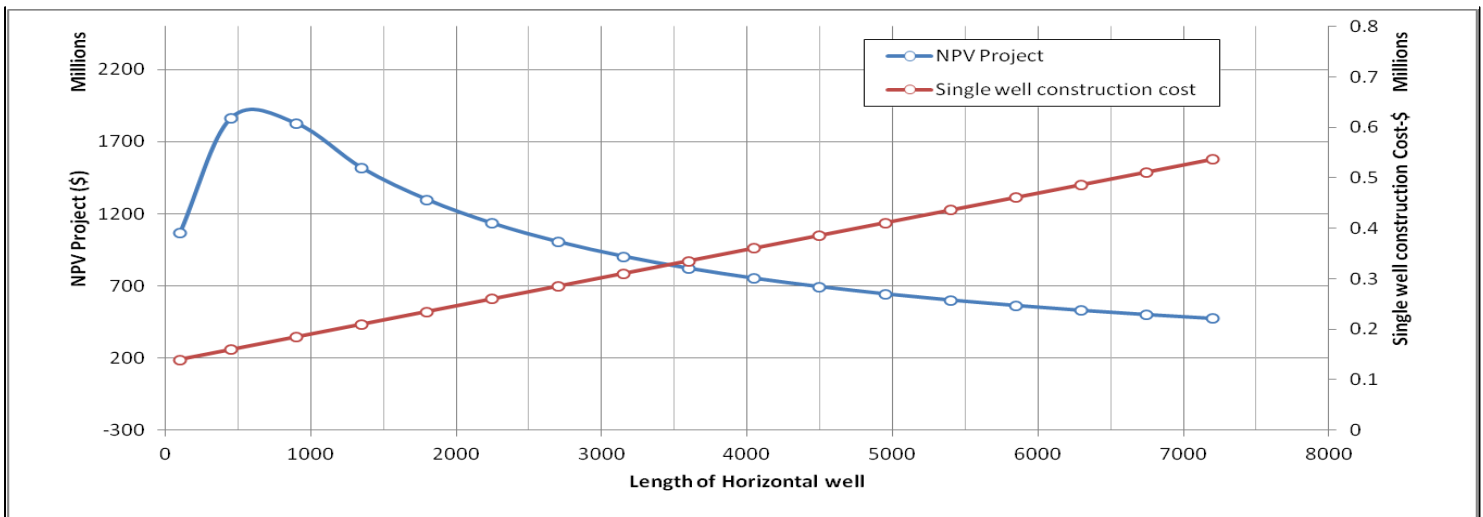

Fig4.41 NPV project and Single Well Construction Cost v/s Horizontal Well Length for Case-5(b)

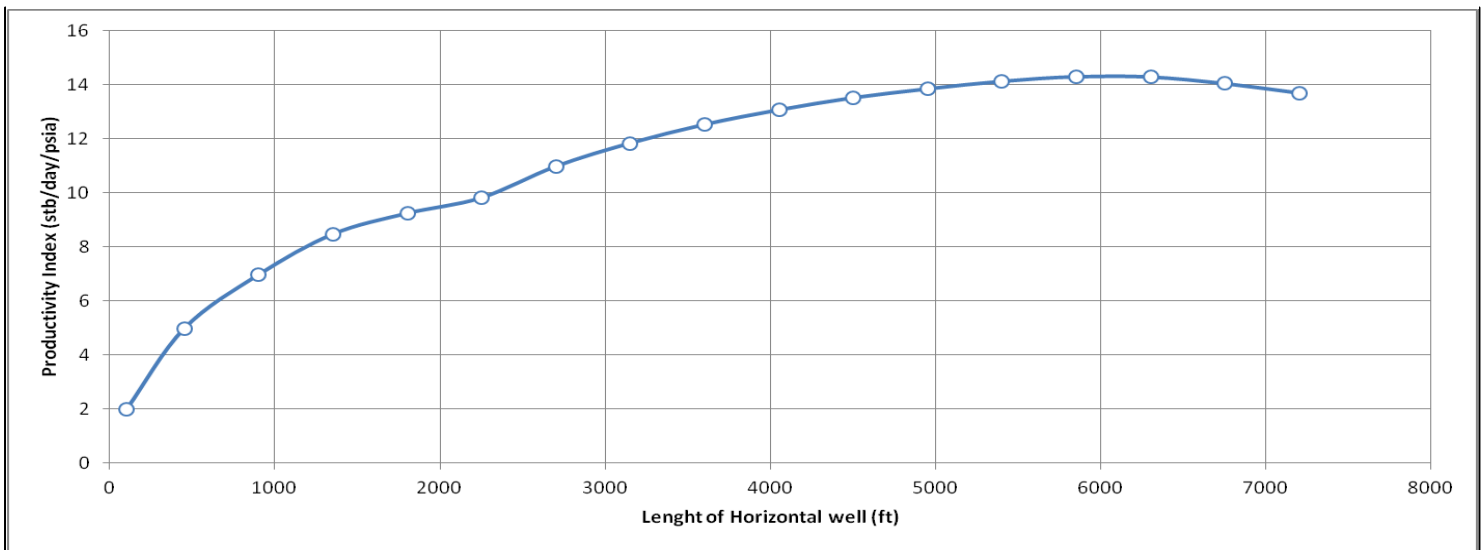

Fig4.42 Productivity Index v/s Horizontal Well Length for Case-5(b)

#### 4.15 Case-5 (c)

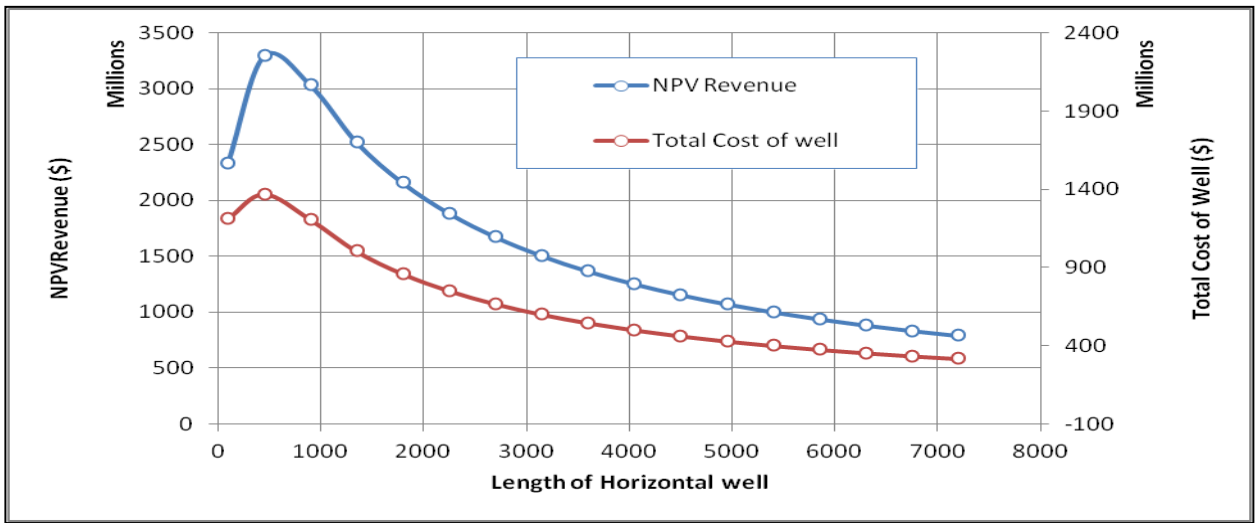

Fig 4.43 NPV and Total Cost v/s Horizontal Well Length for Case-5(c)

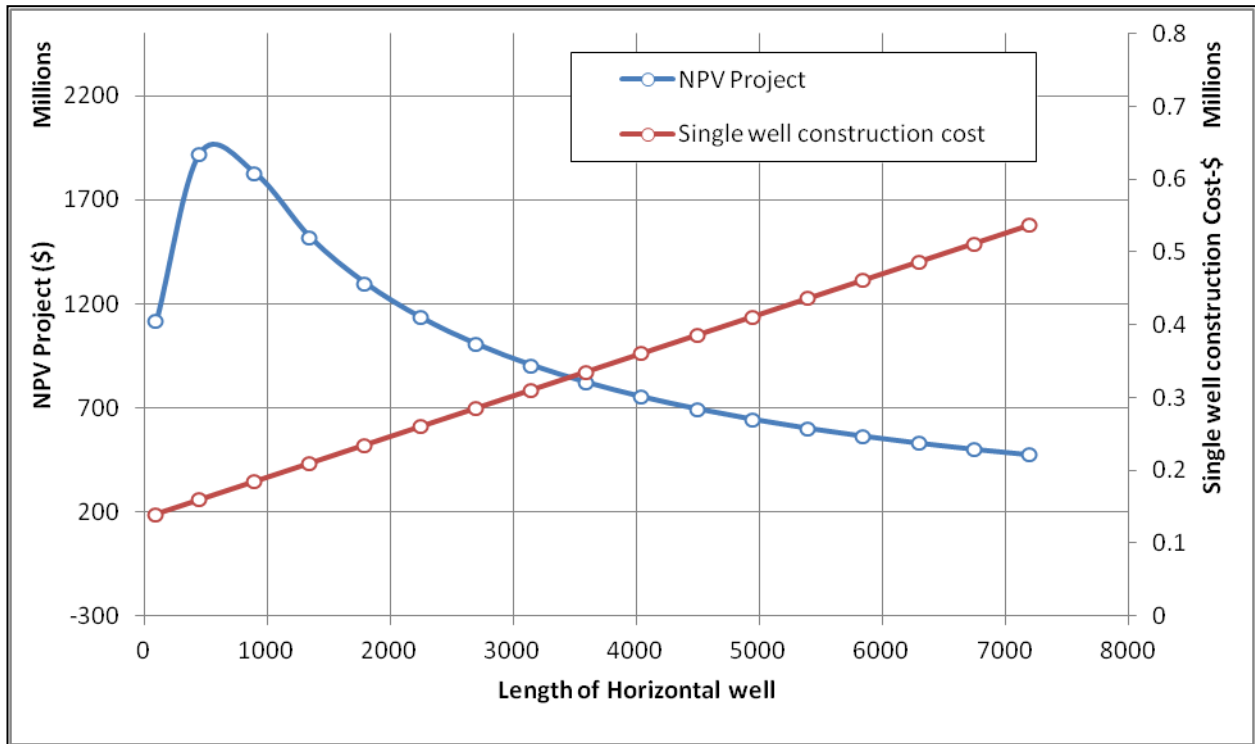

Fig4.44 NPV project and Single Well Construction Cost v/s Horizontal Well Length for Case-5(c)

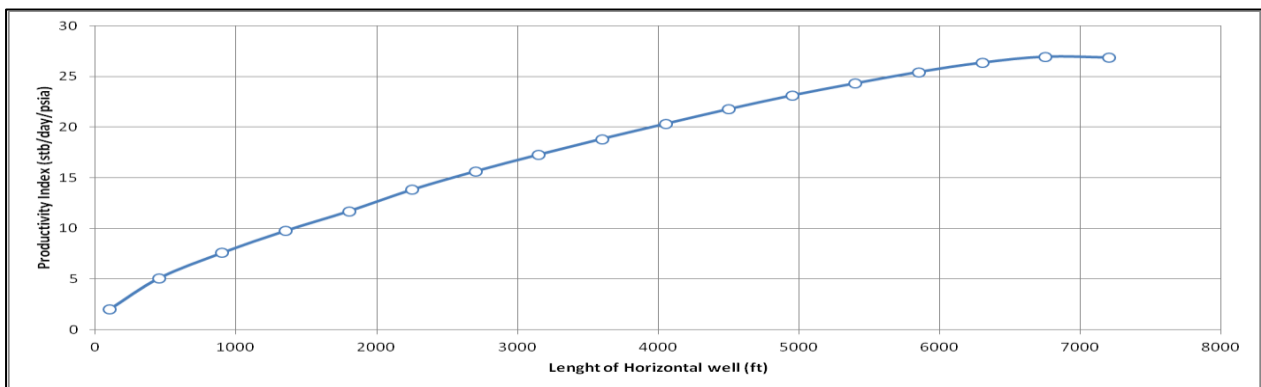

Fig4.45 Productivity Index v/s Horizontal Well Length for Case-5(c)

4.16 Case-6(a) , 4.17 Case-6(b)

& 4.18 Case-6(c)

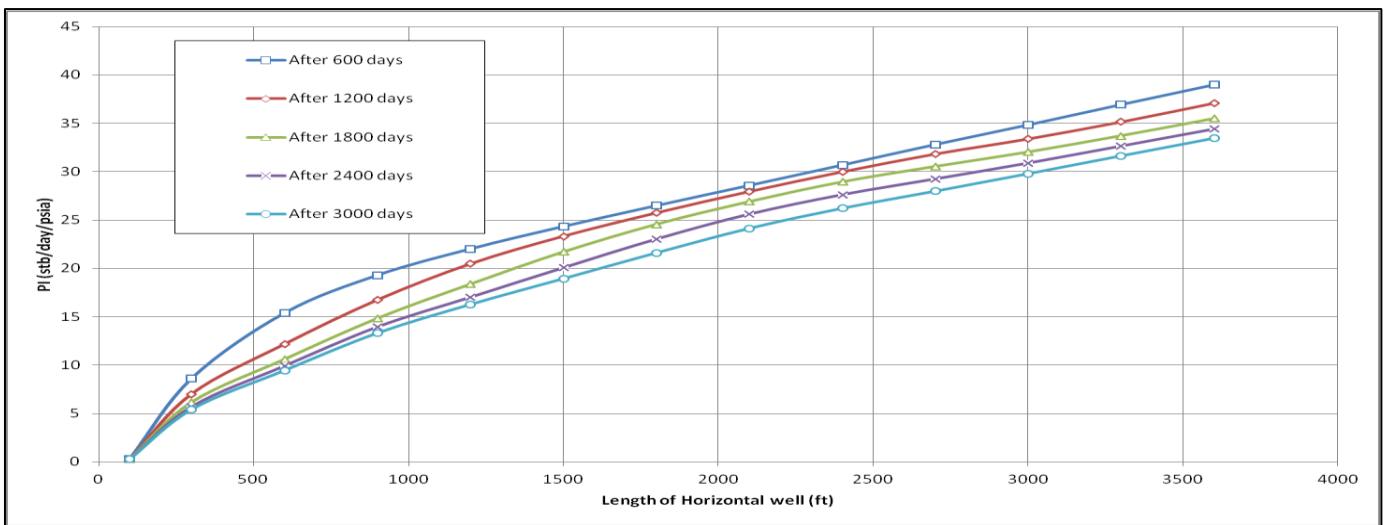

Fig4.46 Productivity Index v/s Horizontal Well Length for Case-6(a)

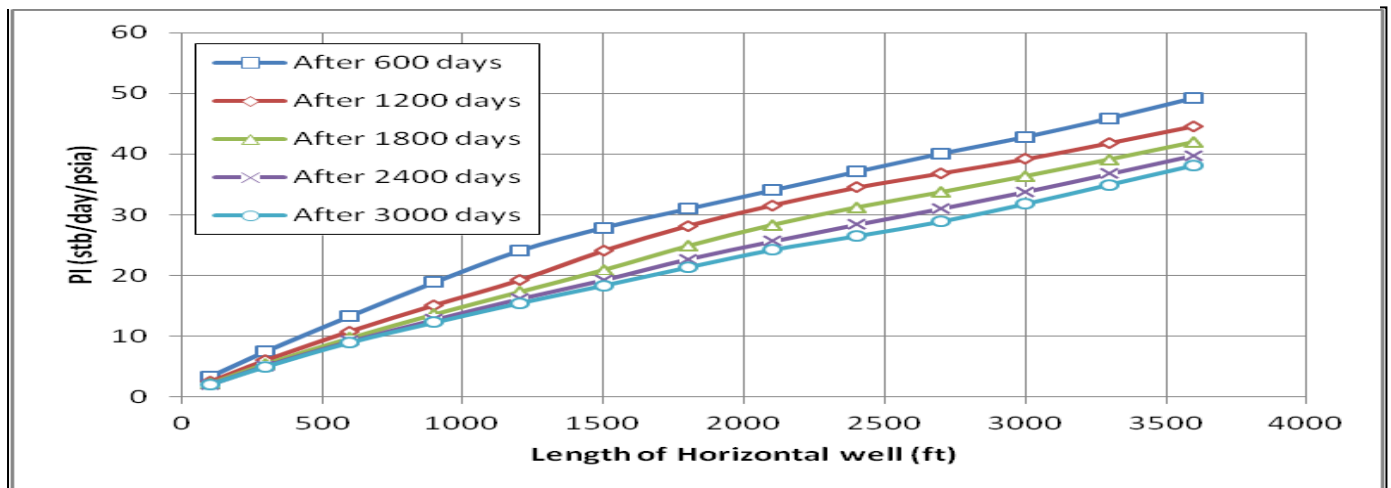

Fig4.47 Productivity Index v/s Horizontal Well Length for Case-6(b)

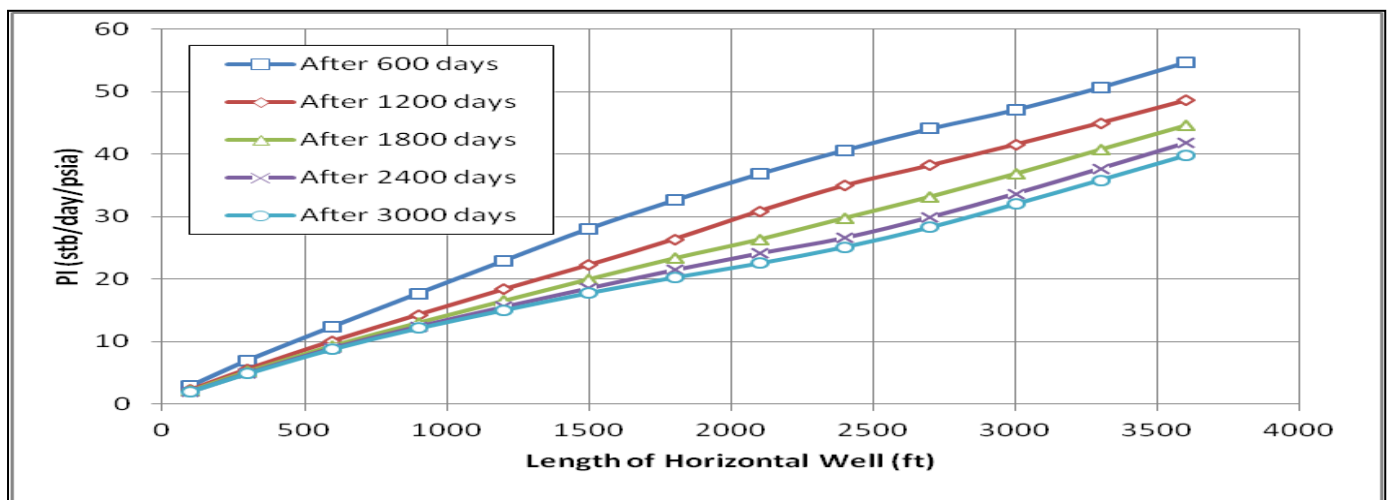

Fig4.48 Productivity Index v/s Horizontal Well Length for Case-6(c)

## 5. DISCUSSION ON RESULTS

### 5.1 Case-1(a), Case-1(b) and Case-1(c)

In all these cases, optimum length is found out to be between 450 to 500 ft. (Fig 4.1, Fig 4.4 and 4.7).

Starting from the well length of just 100 ft. , all markers such as high flow rates, high NPV and direct proportional rise in productivity index is observed but there is a sudden decline in all these parameters after reaching 450-500 ft. This decline is continued as the well length is increasing. Decline in productivity is not due to higher flow rates but due to increased well length

Well operating in Case-1 (a) at comparatively lowest bottom hole flowing pressure from the other two cases has yielded highest amount of NPV Project because it has allowed more oil and gas to produce. Resultantly, Recovery factor of Case-1(a) is highest when compared with other two (Appendix Fig 10.2, Fig 10.5 and Fig. 10.8)

Well Lengths ranging from 2500 to above are not contributing to flow after two or three years (Fig 4.3, 4.6 and 4.9) in all these three cases whereas the shorter well lengths are still producing, though not at very high flow rates.

Well costs are direct in proportion (Fig 4.2, 4.5 and 4.8) with their lengths and this rise in cost is not economical as the longer wells are not producing.

### 5.2 Case-2(a), Case-2(b) and Case-2(c)

In Case-2(a), optimum length is found out to be 1000 ft. and for the remaining two cases, it is 450-500 ft. (Fig. 4.10, 4.13 and 4.16)

Well in Case-2(a) was allowed to produce on 2000 stb/day by allowing a very little drawdown i.e. 50 psia, and at the end of 5 years, only longer well lengths was able to maintain this flow rate (Fig 10.10 in Appendix). Larger drawdowns were allowed in Case-2(b) and Case-2(c) and at the end of 5 years, smaller well lengths were also able to maintain the desired flow rates (Fig 10.13 and 10.16 in Appendix)

Lengths which were able to maintain desired flow rates in all three cases had the same recovery rate at the end of simulation i.e. 5 years

A stabilized well bottom hole flowing pressure was seen in all three cases but after a certain length i.e. 3000 ft. This mean shorter well lengths could not produce desired oil rates with the allowable drawdown and resultant water production caused the bottom hole pressure to lower down (Fig 10.12, 10.15 and 10.18).

Productivity Index did not have a clear trend (Fig 4.12, fig 4.15 and 4.18) but wellbore hydraulics effects are seen. Productivity index , when compared in these three cases was found out to be higher in the one producing at lowest allowable drawdown.

Method suggested by Novy [16] stood right in Cases-2(b) and 2(c) where the well length producing at 90% of the maximum flow rate was regarded as the optimal one. (Fig 10.13 and 10.16)

### **5.3 Case-3(a) , Case-3(b) and Case-3(c)**

In Case-3(a), optimum length is found out to be 1000 ft. and for the remaining two cases, it is 450-500 ft. (Fig. 4.19, 4.22 and 4.25)

Almost identical results were obtained in Case-3 when compared to Case-2. The probable reason can be the negligible impact of friction to flow of oil in Case-2 and Case-3 because of not high enough flow rates.

However, the absence of friction factor in case 3 caused well construction cost to lower slightly and all productivity indices (oil flow + water flow) showed direct proportion with well lengths.

#### **5.4 Case-4(a) , Case-4(b) and Case-4(c)**

As far as the NPV Revenue and NPV Project are concerned, All these cases produced same results although having difference in relative well bore roughness (Fig 4.28, 4.31 and 4.34). Slight difference is obtained in well construction costs because of difference in quality of pipes used. Prices of pipes were not directly adjusted but the construction cost in the main calculations were altered to some extent.

All these three cases were run at low velocities in order to see the effects of well lengths only on the productivity Index. Productivity Index started to decrease at well lengths of 4000 ft.

After seeing relative values of productivity indices, the well using lowest amount of wellbore friction was the open producing with highest productivity Index (Fig 4.30, 4.33 and 4.36)

Referring to Well bottom hole pressure, well operating on highest friction factor was the one having lowest bottom hole pressures compared to other wells of same case. (Fig 10.30, 10.33 and 10.36)

Optimal length in all three cases were 500-700 ft. and these were found to in good agreement with Novy [12] optimal well length method.

#### **5.5 Case-5(a) , Case-5(b) and Case-5(c)**

In all these cases, length was seen to be optimal at 500-600 ft. (Fig 4.37 to fig 4.44) and it is same in all these three cases despite having different wellbore diameters. Well bore construction costs were slightly different because of difference in pipe diameters used. This cost was adjusted in construction cost calculations.

Effects of diameters are seen on productivity Index curve where the wellbore having smallest diameter was having lowest productivity index relative values.

Wellbore hydraulics started to play its role for relatively shorter well length in the case of smaller diameters holes.(Fig 4.39, 4.42 and 4.45). This means wellbore diameter is an important parameter that effects productivity Index of



well. Larger the wellbore diameter, smaller is the amount of wellbore hydraulics but this factor needs to be compromised with higher prices of large diameter pipes.

### **5.6 Case-6(a), Case-6(b) and Case-6(c)**

In all these cases, no economic evaluation is made, but the effects of injection well on the performance of production well is observed. Fig 4.46, 4.47 and 4.48 show direct proportion of productivity Index with well lengths.

Among these three cases, well producing on lower amount of flow rate yield highest amount of Productivity Index. The injection well is producing at constant bottom hole pressure, so it is providing same amount of energy to producing wells. The reason of highest productivity Index is the lowest flow rate, because less amounts of flow rates causes less frictional pressure drops.

Continued increase in well length also causes additional pressure drops which can be seen in lower amounts of oil rates after the length of 1800-2000 ft.

## 6. SIMULATOR LIMITATIONS

### 6.1 Discussion of Allowable Drawdown limit

When Wells produce under the constraints of allowable drawdown, then at each time step, this maximum allowable drawdown is converted to maximum production rate [29] of the selected phase by using the following equation

$$Q_{max} = D_{max} \sum_j (T_{wj} M_j) \text{ -----Eq.42}$$

$T_{wj} M_j$  is obtained after considering all open connection of well. This method is quite good to calculate drawdown as:

$$D = P_{av} - P_w \text{ -----Eq.43}$$

$$P_{av} = \frac{\sum_j (T_{wj} M_j (P_j - H_{wj}))}{\sum_j (T_{wj} M_j)} \text{ -----Eq.44}$$

There is another method to apply constraints on maximum allowable drawdown limits for open connections of well. This option is turned on by setting item 5 of the key word 'WELDRAW' to 'MAX' [29]. For maximum allowable drawdown limit, minimum bottom hole pressure is calculated as:

$$P_{w,min} = \text{Max}_j (P_j - H_{wj} - D_{max}) \text{ -----Eq.45}$$

This minimum BHP, then converts to maximum flow rate as:

$$Q_{max} = \sum_j (T_{wj} M_j (P_j - H_{wj} - P_{w,min})) \text{ -----Eq.46}$$

As  $Q_{max}$  is effected heavily by the mobility of the selected phase, wells may produce at different flow rates at each iteration because of changes in mobility [29]. This may cause slow convergence rate for the Newtonian Iterations

Therefore,  $Q_{max}$  is calculated only for the first time step and remains unchanged for the upcoming time steps. This causes actual drawdown to deviate [29] to an extent depending upon selected phase mobility.

## 6.2 Discussion on Average reservoir pressure

Productivity Index throughout the course of simulation was found earlier through the use of Eq. 35 which is:

$$PI = \frac{FLPR}{(FPR - WBHP)} \text{ in } \frac{stb}{day}/psia$$

Instead of using this method, the simulator summary section word 'WPI' (Well productivity index) could have been used as a convenient way for calculation.

Simulator [29] calculates WPI with the help following calculation:

$$J = \sum_j T_{wj} M_{pj} \left( \frac{\ln\left(\frac{r_o}{r_w}\right) + S}{\ln\left(\frac{r_d}{r_w}\right) + S} \right) \quad \text{Eq.47}$$

Where  $\sum_j$  depicts a sum over all connections pertaining to well.

But this calculation of PI was not suitable for the case of Horizontal well. The reason for this instruction was that the above eq. 34 required that a steady state flow regime should have been occurred orthogonal to the wellbore, but this flow regime would be quickly disconnected by the formation boundaries and final flow regime would be linear or pseudo radial depending upon the well geometry and drainage area [29].

Another reason for no usage of WPI was based on the fact as drainage radius was commonly not available for input in the simulator, the simulator itself used to take default values of it which were the values of the connecting grids at the pressure equivalent radii and set it for all the connections. Therefore this technique replaced PI at the drainage radius to the PI of the well with its connecting grids.

Therefore, the keyword 'FPR' in this projects work was assumed to be representative of reservoir pressure at the drainage radius and this assumption was permitted [29].

## **7. SOURCES OF ERRORS**

### **7.1 Well Costs**

Cost of drilling, completion, varies with well location, reservoir properties, therefore any method that is adopted for economic calculations may deviate from the real life values. Operating Cost and Overhead Cost that were kept constant for all well lengths ranging from 100 ft. to 7200 ft. is not a realistic assumption. Drilling Cost per foot of the horizontal section was treated as a linear function of well length but a census [30] show that drilling cost per foot depicts different behavior.

Discount rates may vary from year to year, so as the Hydrocarbon prices, but all these were kept constant in this study

Calculation of Tax is another important factor which is computed with different methods as per the policies of countries. In this study , a fairly simple technique of fixed and variable costs is used.

Construction costs adjustments owing to use of different qualities pipe (Variation in diameters and roughness) should be adjusted based on their comparative prices.

Therefore, all these assumptions should be kept in mind when dealing with real life solutions.

### **7.2 Discussion on Wellbore pressure drops calculation**

In the previous chapter, the 'Percentage of wellbore pressure drop to the drawdown' was calculated for every case. For many cases, this percentage was above the percentage stated by Novy [12]. This might be for the following reasons:

- Overestimated observation from the data given in Appendix
- Overestimated observation from the data in graphs

One more thing that could have been done was to adopt another strategy to calculate wellbore pressure drops. In my project work, wellbore pressure drops were calculated by the following equation 36:

$$(\Delta p) = (CPR - WBHP) \quad \text{in psia}$$

The other strategy could have been:

$$(\Delta p) = (CPR_{AT\ TOE} - CPR_{AT\ HEEL}) \quad \text{in psia} \quad \text{Eq. 48}$$

These two strategies may produce different results

### **7.3 Steady state or transient Productivity Index**

An important feature was to use steady state or pseudo steady state condition for the PI measurement. In this project work, PI was measured constantly from the start of production. Early days in production belong to transient flow, and from the data produced, there wasn't any indication when the pseudo steady state began, so this was one possible source of error that should be corrected in the future work.

## 8. CONCLUSION

- Frictional pressure drops in horizontal wells occur in producing wells either due to high flow rates or increasing well bore length.
- For lower flow rates , wellbore hydraulics don't hinder productivity and the flow remains Laminar.
- Effects of wellbore hydraulics can be seen when flow rates starting in the order of 2600 stb/day are observed in the well bore lengths of 3000-4000 ft. for well diameter of 2.5 inches.
- Effects of wellbore hydraulics can be seen when flow rates starting in the order of 1600 stb/day are observed in the well bore lengths of 3000-4000 ft. for well diameter of 2.5 inches and wellbore roughness in the order of 0.01.
- For lower flow rates in the order of 2600 stb/day, all wellbore diameters gave same amount of NPV.
- For lower flow rates in the order of 1600 stb/day, all wellbore roughness values gave same amount of NPV.
- Optimal length of wellbore should be investigated by the integration of well bore hydraulics, well costs analysis and life of the well.
- Relatively short well lengths in all cases gave highest amounts of NPV.
- For constant bottom hole pressure conditions, sufficiently long well lengths become least economical early in life of well.
- Through the use of injection wells, effects of well bore hydraulics may be dealt to some extent.

## 9. RECOMMENDATIONS/FUTURE WORK

- Productivity analysis for all of the above conditions should be made with involvement of higher flow rates such as in the order of 3000-5000 stb/day
- Designing Objective functions based on optimization of NPV, flow rates, bottom hole flowing pressures , well lengths and well diameters are possible future work.

## 10. REFERENCES

- [1] S. L. B. & R. I. Hyun Cho, «Integrated Optimization on a long Horizontal Well Length,» *SPE Reservoir Evaluation & Engineering*, 2003.
- [2] S. Joshi, *Horizontal well technology*, 1991.
- [3] F. G. (Horwell), «Low-Permeability Reservoirs Development Using Horizontal Wells,» i *Low Permeability Reservoirs Symposium, 18-19 May*, , Denver, Colorado, 1987.
- [4] S. Joshi, «Augmentation of Well Productivity With Slant and Horizontal Wells,» *Journal of Petroleum Technology*, 1988.
- [5] M. & R. D. W. Muskat, *The flow of homogeneous fluids through porous media*, New York, London, McGraw-Hill Book Co., 1937.
- [6] G. R. (. F. d. P. |. J. D. (Horwell), «Formation Damage Effects on Horizontal-Well Flow Efficiency,» *Journal of Petroleum Technology*, 1991.
- [7] B. J. D. (. E. Laboratorium), «Pressure Drop in Horizontal Wells and Its Effect on Production Performance,» *Journal of Petroleum Technology*, 1990.
- [8] S. F. E. R. C. a. M. W. S. U. o. O. E.G. Anklam, «Horizontal Well Productivity and Wellbore Pressure behaviour Incorporating Wellbore Hydraulics,» i *SPE Production and Operations Symposium*, Oklohama, 2005.
- [9] C. S. S. M. a. J. P. B. H. Yuan, «An Experimental and Analytical Study of Single-Phase Liquid Flow in a Horizontal Well,» *Energy Resour. Technol.*, p. 6, 1997.
- [10] J. K. P. O. Harald Asheim, «A flow resistance correlation for completed wellbore,» *Journal of Petroleum Science and Engineering*, vol. 8, nr. 2, pp. 97-104, 1992.
- [11] S. a. S. L. S. N. H. A. Kristian Brekke, «New, Simple Completion Methods for Horizontal Wells Improve Production Performance in High-Permeability Thin Oil Zones,» *SPE Drilling & Completion*, vol. 9, pp. 205-209, 1994.
- [12] R. M. R. a. D. C. Novy, «Pressure Drops in Horizontal Wells: When Can They Be Ignored?,» *SPE Reservoir Engineering*, vol. 10, pp. 29-35, 1995.
- [13] S. Haaland, *Trans. ASME, JFE*, 1983.
- [14] K. S. (. H. A. |. I. A. (. H. A. |. S. C. L. (. H. A. |. P. R. (. S. Intercomp), «Considering Wellbore Friction in Planning Horizontal Wells,» *Journal of Petroleum Technology*, 1993.



- [15] A. K. Jain, «Accurate Explicit Equation for Friction Factor,» *Journal of the Hydraulics Division*, pp. 674-677, 1976.
- [16] R. Novy, «Pressure drops in Horizontal wells: When can they be ignored?,» *SPE Reservoir Engineering*, 1995.
- [17] W. J. M. W. Gregory Deskins, «SURVEY SHOWS SUCCESSES, FAILURES OF HORIZONTAL WELLS,» *Oil and Gas Journal*, 1995.
- [18] W. a. S. J. S. Lacy, «Horizontal well Applications and Parameters for Economic Success,» i *SPE Latin American Petroleum Engineering Conference*, Caracas, 1992.
- [19] V. P. (. U. S. A. (. U. K. A. (. U.), «Effects of Pressure Drop in Horizontal Wells and Optimum Well Length,» *SPE Journal*, nr. 1999.
- [20] G. Moritis, «HORIZONTAL DRILLING SCORES MORE SUCCESSES,» *Oil and Gas Journal*, 1990.
- [21] «Sizing up Well costs in Most Drilled Depth Ranges in Focus: Drilling,» 1997.
- [22] H. & S. Shah, «Optimization of Well length for Horizontal drilling,» i *Petroleum Society's Canada Intl. Petroleum Conference*, Calgary, 2000.
- [23] J. Kleppe, «Index of /~kleppe/pub/SPE-COMPARATIVE/ECLIPSE\_DATA,» 2011.
- [24] L. C. D. A. S. R. C. M. G. Nghiem, «Seventh SPE Comparative Solution Project: Modelling of Horizontal Wells in Reservoir Simulation,» i *SPE Symposium on Reservoir Simulation*, California, 1991.
- [25] H. H. G. a. A. I. Weinstein, J. S. D. C. Chappellear og J. J. N. a. A. Nolen, «Second Comparative Solution Project: A Three-Phase Coning Study,» *Journal of Petroleum Technology*, vol. 38, pp. 345-353, 1986.
- [26] Schlumberger, «Oil Field Glossary, average reservoir pressure,» Schlumberger.
- [27] «Oil and Gas Lease Equipment and Operating Costs 1994 through 2009,» 2010.
- [28] «Well Cost Study,» Well Cost Data and Consulting by N.L. Fisher Supervision and Engineering Limited, [Internett]. Available: [http://www.pfac.ca/wp-content/uploads/wcs\\_sample.pdf](http://www.pfac.ca/wp-content/uploads/wcs_sample.pdf). [Funnet 14 May 2014].
- [29] Eclipse Reservoir Simulation Software (Technical Description), Schlumberger.
- [30] Y. Hu, «An application of Optimal Design method on Horizontal wellbore length design,» *Modern Applied Science*, 2010.





## 11. APPENDIX

### Sample NPV Calculations table

Discount Rate = 8%

Capital Cost=15% of Construction Cost

Fixed Tax = 3400 \$ per acre

Variable Tax = 28% on sale of well head oil and gas

Yearly Average Oil price = 102 \$ per barrel (Constant for all year)

Yearly Average Gas price = 4 \$ per MSCF (Constant for all year)

Length	Year	Revenue	O.C.	O.H.	Construction	Capital Cost	Taxes	Net Exp.	NCF	Discounted cash flow	NPV Revenue	NPV Cost
100 ft	0	0	3E+06	1E+07	436643	65496.5	2E+06	1.6E+07	-2E+07	-16183929.85	0	16183929.85
	1	88913888.4	3E+06	1E+07		65496.5	3E+07	4.1E+07	5E+07	44695104.76	82327674.44	37632569.68
	2	45498511.6	3E+06	1E+07		65496.5	1E+07	2.8E+07	2E+07	14584740.95	39007640.26	24422899.31
	3	32634264	3E+06	1E+07		65496.5	1E+07	2.5E+07	8E+06	6151710.53	25906130.93	19754420.39
	4	26215978	3E+06	1E+07		65496.5	9E+06	2.3E+07	3E+06	2299333.36	19269526.45	16970193.09
	5	22209928	3E+06	1E+07		65496.5	8E+06	2.2E+07	243862	165968.15	15115703.80	14949735.66
											<b>51712927.91</b>	181626675.88

Length	Year	Revenue	O.C.	O.H.	Construction	Capital Cost	Taxes	Net Exp.	NCF	Discounted cash flow	NPV Revenue	NPV Cost
450 ft	0	0	3E+06	1E+07	468705	70305.7	2E+06	1.6E+07	-2E+07	-16220800.26	0	16220800.26
	1	156981238.00	3E+06	1E+07		70305.7	5E+07	6E+07	1E+08	90068884.88	145352998.15	55284113.27
	2	67910022.00	3E+06	1E+07		70305.7	2E+07	3.5E+07	3E+07	28414883.53	58221898.15	29807014.61
	3	44979234.00	3E+06	1E+07		70305.7	1E+07	2.8E+07	2E+07	13203774.19	35705966.13	22502191.93
	4	32228820.00	3E+06	1E+07		70305.7	1E+07	2.5E+07	7E+06	5477923.70	23689144.82	18211221.12
	5	24000418.00	3E+06	1E+07		70305.7	9E+06	2.2E+07	2E+06	1040070.83	16334281.21	15294210.38
											<b>121984736.87</b>	279304288.45

Length	Year	Revenue	O.C.	O.H.	Construction	Capital Cost	Taxes	Net Exp.	NCF	Discounted cash flow	NPV Revenue	NPV Cost
900 ft	0	0	3E+06	1E+07	509926	76488.9	2E+06	1.6E+07	-2E+07	-16268205.07	0	16268205.07
	1	215590480	3E+06	1E+07		76488.9	6E+07	7.6E+07	1E+08	129135987.66	199620814.81	70484827.15
	2	75538262	3E+06	1E+07		76488.9	2E+07	3.7E+07	4E+07	33118372.53	64761884.43	31643511.90
	3	44378050	3E+06	1E+07		76488.9	1E+07	2.8E+07	2E+07	12855253.48	35228726.88	22373473.40
	4	27596894	3E+06	1E+07		76488.9	1E+07	2.3E+07	4E+06	3022064.04	20284540.93	17262476.90
	5	17458792	3E+06	1E+07		76488.9	7E+06	2.1E+07	-3E+06	-2169664.31	11882160.48	14051824.78
										<b>159693808.33</b>	331778127.54	172084319.20

Length	Year	Revenue	O.C.	O.H.	Construction	Capital Cost	Taxes	Net Exp.	NCF	Discounted cash flow	NPV Revenue	NPV Cost
1350 ft	0	0	3E+06	1E+07	551148	82672.2	2E+06	1.6E+07	-2E+07	-16315609.88	0	16315609.88
	1	254256244	3E+06	1E+07		82672.2	7E+07	8.7E+07	2E+08	154907438.45	235422448.15	80515009.70
	2	78711996	3E+06	1E+07		82672.2	2E+07	3.8E+07	4E+07	35072166.46	67482849.79	32410683.33
	3	40925520	3E+06	1E+07		82672.2	1E+07	2.7E+07	1E+07	10877019.70	32487997.26	21610977.56
	4	22284374	3E+06	1E+07		82672.2	8E+06	2.2E+07	280287	206019.40	16379680.14	16173660.74
	5	11925726	3E+06	1E+07		82672.2	5E+06	1.9E+07	-7E+06	-4885184.97	8116448.73	13001633.70
										<b>179861849.15</b>	359889424.07	180027574.91

Length	Year	Revenue	O.C.	O.H.	Construction	Capital Cost	Taxes	Net Exp.	NCF	Discounted cash flow	NPV Revenue	NPV Cost
1800 ft	0	0	3E+06	1E+07	592369	88855.4	2E+06	1.6E+07	-2E+07	-16363014.7	0	16363014.7
	1	282500572	3E+06	1E+07		0	8E+07	9.5E+07	2E+08	173813538.74	261574603.70	87761064.96
	2	81390296	3E+06	1E+07		0	2E+07	3.8E+07	4E+07	36796316.12	69779060.36	32982744.24
	3	38038228	3E+06	1E+07		0	1E+07	2.6E+07	1E+07	9292389.18	30195971.78	20903582.60
	4	17963104	3E+06	1E+07		0	7E+06	2.1E+07	-3E+06	-2020123.06	13203417.69	15223540.75
	5	8105332	3E+06	1E+07		0	4E+06	1.8E+07	-1E+07	-6700988.78	5516352.77	12217341.55
										<b>194818117.50</b>	380269406.29	185451288.79

Length	Year	Revenue	O.C.	O.H.	Construction	Capital Cost	Taxes	Net Exp.	NCF	Discounted cash flow	NPV Revenue	NPV Cost
2250 ft	0	0	3E+06	1E+07	633591	95038.6	2E+06	1.6E+07	-2E+07	-16410419.51	0	16410419.51
	1	303594074	3E+06	1E+07		0	9E+07	1E+08	2E+08	187875873.41	281105624.07	93229750.67
	2	84655034	3E+06	1E+07		0	3E+07	3.9E+07	5E+07	38811586.49	72578046.98	33766460.49
	3	35495680	3E+06	1E+07		0	1E+07	2.6E+07	1E+07	7839172.45	28177615.20	20338442.76
	4	14487788	3E+06	1E+07		0	6E+06	2E+07	-5E+06	-3859334.98	10648956.68	14508291.67
	5	5284206	3E+06	1E+07		0	3E+06	1.7E+07	-1E+07	-8083396.67	3596341.81	11679738.48
										<b>206173481.18</b>	396106584.75	189933103.57

Length	Year	Revenue	O.C.	O.H.	Construction	Capital Cost	Taxes	Net Exp.	NCF	Discounted cash flow	NPV Revenue	NPV Cost
2700 ft	0	0	3E+06	1E+07	674812	101222	2E+06	1.6E+07	-2E+07	-16457824.32	0	16457824.32
	1	319276494	3E+06	1E+07		101222	9E+07	1.1E+08	2E+08	198237096.12	295626383.33	97389287.21
	2	88178260	3E+06	1E+07		101222	3E+07	4E+07	5E+07	40899635.92	75598645.40	34699009.49
	3	33494344	3E+06	1E+07		101222	1E+07	2.5E+07	8E+06	6614937.23	26588890.16	19973952.93
	4	11436378	3E+06	1E+07		101222	5E+06	1.9E+07	-8E+06	-5548607.84	8406079.24	13954687.08
	5	3245014	3E+06	1E+07		101222	3E+06	1.7E+07	-1E+07	-9151531.23	2208502.00	11360033.24
										<b>214593705.88</b>	408428500.14	193834794.25

Length	Year	Revenue	O.C.	O.H.	Construction	Capital Cost	Taxes	Net Exp.	NCF	Discounted cash flow	NPV Revenue	NPV Cost
3150 ft	0	0	3E+06	1E+07	716034	107405	2E+06	1.7E+07	-2E+07	-16505229.13	0	16505229.13
	1	330784042	3E+06	1E+07		107405	9E+07	1.1E+08	2E+08	205903069.57	306281520.37	100378450.80
	2	91493880	3E+06	1E+07		107405	3E+07	4.1E+07	5E+07	42941013.80	78441255.14	35500241.34
	3	31534306	3E+06	1E+07		107405	1E+07	2.5E+07	7E+06	5489751.00	25032948.80	19543197.80
	4	8907664	3E+06	1E+07		107405	4E+06	1.8E+07	-9E+06	-6891402.50	6547398.96	13438801.46
	5	1959160	3E+06	1E+07		107405	2E+06	1.6E+07	-1E+07	-9785833.49	1333371.38	11119204.87
										<b>221151369.25</b>	417636494.65	196485125.40

Length	Year	Revenue	O.C.	O.H.	Construction	Capital Cost	Taxes	Net Exp.	NCF	Discounted cash flow	NPV Revenue	NPV Cost
3600 ft	0	0	3E+06	1E+07	757256	113588	2E+06	1.7E+07	-2E+07	-16552633.94	0	16552633.94
	1	339094920	3E+06	1E+07		113588	1E+08	1.1E+08	2E+08	211437929.69	313976777.78	102538848.09
	2	94282566	3E+06	1E+07		113588	3E+07	4.2E+07	5E+07	44657123.78	80832103.91	36174980.13
	3	29926204	3E+06	1E+07		113588	1E+07	2.4E+07	6E+06	4565717.04	23756385.59	19190668.55
	4	6887826	3E+06	1E+07		113588	4E+06	1.8E+07	-1E+07	-7964889.05	5062757.73	13027646.78
	5	1172576	3E+06	1E+07		113588	2E+06	1.6E+07	-1E+07	-10175483.51	798035.52	10973519.04
										<b>225967764.00</b>	424426060.53	198458296.53

Length	Year	Revenue	O.C.	O.H.	Construction	Capital Cost	Taxes	Net Exp.	NCF	Discounted cash flow	NPV Revenue	NPV Cost
4050 ft	0	0	3E+06	1E+07	798477	119772	2E+06	1.7E+07	-2E+07	-16600038.75	0	16600038.75
	1	345168574	3E+06	1E+07		119772	1E+08	1.1E+08	2E+08	215481307.13	319600531.48	104119224.35
	2	96217356	3E+06	1E+07		119772	3E+07	4.3E+07	5E+07	45846137.47	82490874.49	36644737.02
	3	28299246	3E+06	1E+07		119772	1E+07	2.4E+07	5E+06	3630905.75	22464853.87	18833948.12
	4	5246188	3E+06	1E+07		119772	3E+06	1.7E+07	-1E+07	-8838224.03	3856104.79	12694328.82
	5	698082	3E+06	1E+07		119772	2E+06	1.6E+07	-2E+07	-10412203.22	475102.88	10887306.10
										<b>229107884.35</b>	428887467.51	199779583.16

Length	Year	Revenue	O.C.	O.H.	Construction	Capital Cost	Taxes	Net Exp.	NCF	Discounted cash flow	NPV Revenue	NPV Cost
4500 ft	0	0	3E+06	1E+07	839699	125955	2E+06	1.7E+07	-2E+07	-16647443.56	0	16647443.56
	1	349637978	3E+06	1E+07		125955	1E+08	1.1E+08	2E+08	218455184.58	323738868.52	105283683.94
	2	97379838	3E+06	1E+07		125955	3E+07	4.3E+07	5E+07	46558417.82	83487515.43	36929097.61
	3	26625580	3E+06	1E+07		125955	9E+06	2.3E+07	3E+06	2669398.07	21136243.84	18466845.77
	4	3921696	3E+06	1E+07		125955	3E+06	1.7E+07	-1E+07	-9543718.53	2882563.63	12426282.16
	5	413492	3E+06	1E+07		125955	2E+06	1.6E+07	-2E+07	-10555866.19	281415.71	10837281.90
										<b>230935972.20</b>	431526607.13	200590634.94

Length	Year	Revenue	O.C.	O.H.	Construction	Capital Cost	Taxes	Net Exp.	NCF	Discounted cash flow	NPV Revenue	NPV Cost
4950 ft	0	0	3E+06	1E+07	880920	132138	2E+06	1.7E+07	-2E+07	-16694848.37	0	16694848.37
	1	353001998.00	3E+06	1E+07		132138	1E+08	1.1E+08	2E+08	220692139.36	326853701.85	106161562.49
	2	97922288.00	3E+06	1E+07		132138	3E+07	4.3E+07	5E+07	46887962.37	83952578.88	37064616.50
	3	24968250.00	3E+06	1E+07		132138	9E+06	2.3E+07	2E+06	1717227.39	19820601.85	18103374.46
	4	2910364.00	3E+06	1E+07		132138	3E+06	1.7E+07	-1E+07	-10083482.02	2139204.42	12222686.44
	5	215196.00	3E+06	1E+07		132138	2E+06	1.6E+07	-2E+07	-10657243.39	146458.78	10803702.17
										<b>231861755.34</b>	432912545.78	201050790.44

Length	Year	Revenue	O.C.	O.H.	Construction	Capital Cost	Taxes	Net Exp.	NCF	Discounted cash flow	NPV Revenue	NPV Cost
5400 ft	0	0	3E+06	1E+07	922142	138321	2E+06	1.7E+07	-2E+07	-16742253.19	0	16742253.19
	1	355572330	3E+06	1E+07		138321	1E+08	1.2E+08	2E+08	222399968.81	329233638.89	106833670.08
	2	98050278	3E+06	1E+07		138321	3E+07	4.3E+07	5E+07	46961667.42	84062309.67	37100642.25
	3	23506656	3E+06	1E+07		138321	8E+06	2.2E+07	1E+06	876931.42	18660341.41	17783409.99
	4	2159710	3E+06	1E+07		138321	2E+06	1.6E+07	-1E+07	-10485289.12	1587451.32	12072740.44
	5	63774	3E+06	1E+07		138321	2E+06	1.6E+07	-2E+07	-10735651.39	43403.51	10779054.90
										<b>232275373.96</b>	433587144.81	201311770.85

Length	Year	Revenue	O.C.	O.H.	Construction	Capital Cost	Taxes	Net Exp.	NCF	Discounted cash flow	NPV Revenue	NPV Cost
5850 ft	0	0	3E+06	1E+07	963363	144505	2E+06	1.7E+07	-2E+07	-16789658	0	16789658
	1	357538476	3E+06	1E+07		144505	1E+08	1.2E+08	2E+08	223705007.59	331054144.44	107349136.85
	2	97946574	3E+06	1E+07		144505	3E+07	4.3E+07	5E+07	46892351.47	83973400.21	37081048.73
	3	22242218	3E+06	1E+07		144505	8E+06	2.2E+07	188102	149321.78	17656589.76	17507267.98
	4	1608000	3E+06	1E+07		144505	2E+06	1.6E+07	-1E+07	-10781810.77	1181928.00	11963738.77
	5	0	3E+06	1E+07		144505	2E+06	1.6E+07	-2E+07	-10771110.12	0.00	10771110.12
										<b>232404101.96</b>	433866062.41	201461960.46



Length	Year	Revenue	O.C.	O.H.	Construction	Capital Cost	Taxes	Net Exp.	NCF	Discounted cash flow	NPV Revenue	NPV Cost
6300 ft	0	0	3E+06	1E+07	1004585	150688	2E+06	1.7E+07	-2E+07	-16837062.81	0	16837062.81
	1	358991388	3E+06	1E+07		150688	1E+08	1.2E+08	2E+08	224667890.37	332399433.33	107731542.96
	2	97694028	3E+06	1E+07		150688	3E+07	4.3E+07	5E+07	46731157.75	83756882.72	37025724.96
	3	21200716	3E+06	1E+07		150688	8E+06	2.2E+07	-6E+05	-450866.74	16829811.89	17280678.63
	4	1218740	3E+06	1E+07		150688	2E+06	1.6E+07	-1E+07	-10992360.39	895810.28	11888170.67
	5	46964	3E+06	1E+07		150688	2E+06	1.6E+07	-2E+07	-10752305.03	31962.91	10784267.94
										<b>232366453.16</b>	433913901.13	201547447.98

Length	Year	Revenue	O.C.	O.H.	Construction	Capital Cost	Taxes	Net Exp.	NCF	Discounted cash flow	NPV Revenue	NPV Cost
6750 ft	0	0	3E+06	1E+07	1045807	156871	0	1.5E+07	-2E+07	-15082467.62	0	15082467.62
	1	360017730	3E+06	1E+07		156871	1E+08	1.1E+08	2E+08	227014911.67	333349750.00	106334838.33
	2	97326510	3E+06	1E+07		156871	3E+07	4.1E+07	6E+07	48043918.22	83441795.27	35397877.05
	3	20354680	3E+06	1E+07		156871	6E+06	2E+07	618709	491150.84	16158201.24	15667050.40
	4	849136	3E+06	1E+07		156871	2E+05	1.4E+07	-1E+07	-9867983.84	624140.31	10492124.15
	5	0	3E+06	1E+07		156871	0	1.4E+07	-1E+07	-9553115.61	0.00	9553115.61
										<b>241046413.65</b>	433573886.82	192527473.16

Length	Year	Revenue	O.C.	O.H.	Construction	Capital Cost	Taxes	Net Exp.	NCF	Discounted cash flow	NPV Revenue	NPV Cost
7200 ft	0	0	3E+06	1E+07	1087028	163054	0	1.5E+07	-2E+07	-15129872.43	0	15129872.43
	1	360672000	3E+06	1E+07		163054	1E+08	1.2E+08	2E+08	227445366.45	333955555.56	106510189.10
	2	96883788	3E+06	1E+07		163054	3E+07	4.1E+07	6E+07	47765331.90	83062232.51	35296900.61
	3	19668000	3E+06	1E+07		163054	6E+06	2E+07	118116	93764.11	15613092.52	15519328.41
	4	702712	3E+06	1E+07		163054	2E+05	1.4E+07	-1E+07	-9950019.43	516514.30	10466533.73
	5	0	3E+06	1E+07		163054	0	1.4E+07	-1E+07	-9557323.82	0.00	9557323.82
										<b>240667246.78</b>	433147394.88	192480148.10

**Drainage Area Calculation**

**b = 745 ft.**

<b>a</b>	<b>Drainage Area- Method 1</b>	<b>Drainage Area (Method-2)</b>	<b>Average of M-1 and M-2</b>
795	42.71549102	43.44955148	43.08252125
970	52.11827206	55.42154414	53.7699081
1195	64.20756198	70.81410612	67.51083405
1420	76.29685189	86.2066681	81.25176
1645	88.3861418	101.5992301	94.99268594
1870	100.4754317	116.9917921	108.7336119
2095	112.5647216	132.3843541	122.4745378
2320	124.6540115	147.776916	136.2154638
2545	136.7433014	163.169478	149.9563897
2770	148.8325914	178.56204	163.6973157
2995	160.9218813	193.954602	177.4382416
3220	173.0111712	209.347164	191.1791676
3445	185.1004611	224.739726	204.9200935
3670	197.189751	240.1322879	218.6610195
3895	209.2790409	255.5248499	232.4019454
4120	221.3683308	270.9174119	246.1428714
4345	233.4576207	286.3099739	259.8837973

**NPV (Project, Revenue, Cost Calculations)**

Well length	NPV Revenue of 1 one well	Total NPV Revenue	Cost of 1 one well	Total Cost	NPV of one well	NPV Project	Single Well Cost
100	181626675.88	2234366407	129913747.98	1.6E+09	51712927.91	636171027	436643
450	279304288.45	2753050509	157319551.58	1.55E+09	121984736.87	1202380901	468705
900	331778127.54	2604654647	172084319.20	1.35E+09	159693808.33	1253690902	509926
1350	359889424.07	2347535546	180027574.91	1.17E+09	179861849.15	1173227264	551148
1800	380269406.29	2121666351	185451288.79	1.03E+09	194818117.50	1086963709	592369
2250	396106584.75	1930741436	189933103.57	9.26E+08	206173481.18	1004950936	633591
2700	408428500.14	1767445780	193834794.25	8.39E+08	214593705.88	928639259.4	674812
3150	417636494.65	1624979544	196485125.40	7.65E+08	221151369.25	860476648.1	716034
3600	424426060.53	1500074872	198458296.53	7.01E+08	225967764.00	798651628.9	757256
4050	428887467.51	1388601620	199779583.16	6.47E+08	229107884.35	741778679.8	798477
4500	431526607.13	1288950452	200590634.94	5.99E+08	230935972.20	689795300.8	839699
4950	432912545.78	1200149850	201050790.44	5.57E+08	231861755.34	642783059.9	880920
5400	433587144.81	1121418514	201311770.85	5.21E+08	232275373.96	600750985.8	922142
5850	433866062.41	1051623255	201461960.46	4.88E+08	232404101.96	563311075.4	963363
6300	433913901.13	989554399.8	201547447.98	4.6E+08	232366453.16	529919058.8	1004585
6750	433573886.82	933580398.8	192527473.16	4.15E+08	241046413.65	519026200.2	1045807
7200	433147394.88	883349103.2	192480148.10	3.93E+08	240667246.78	490810285.6	1087028

## FLOW RATES, RECOVERY FACTORS AND BOTTOMHOLE PRESSURE FOR ALL CASES

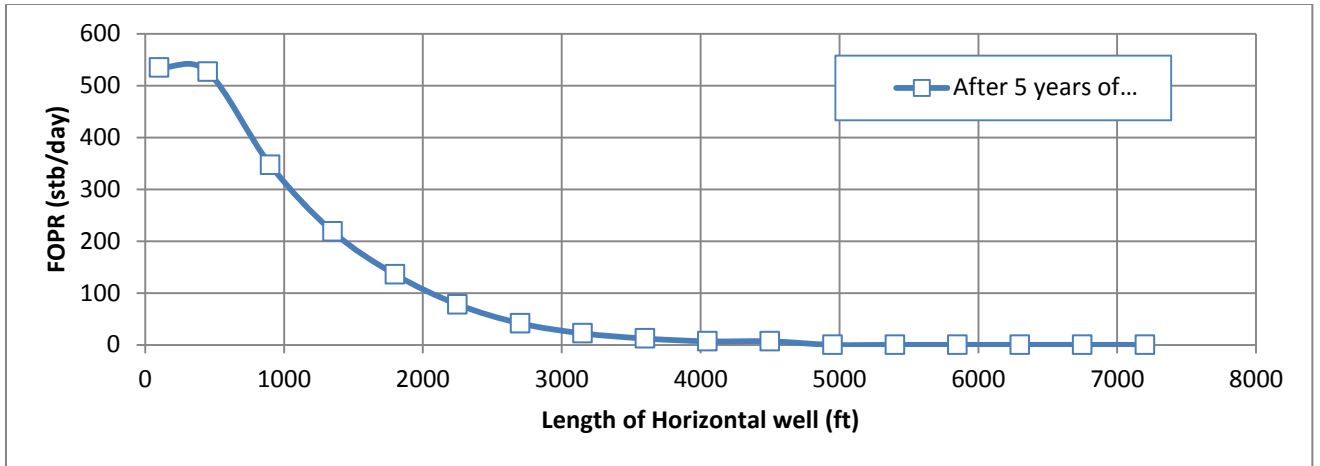

*Fig10.1 Oil well Production Rate for Case-1(a)*

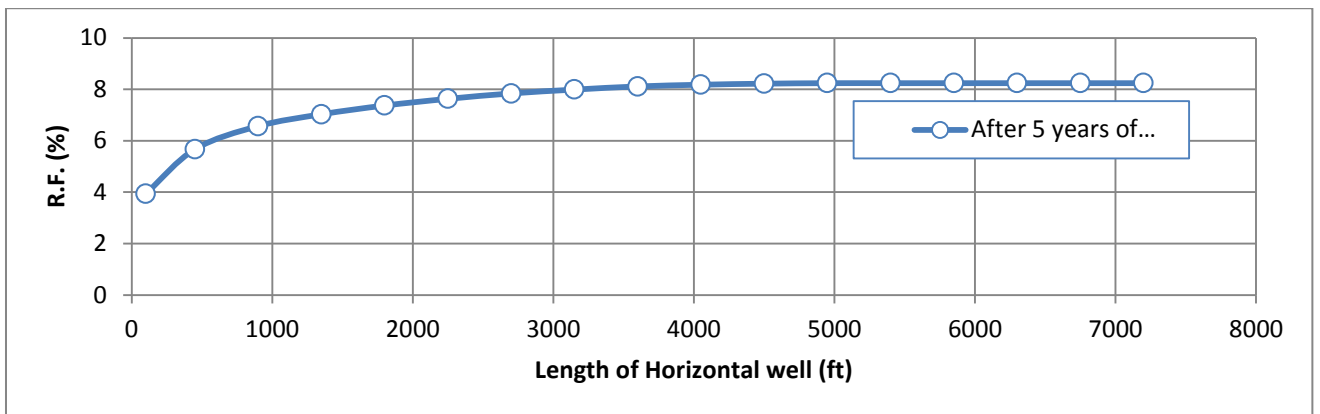

*Fig10.2 Oil Recovery Factor for Case-1(a)*

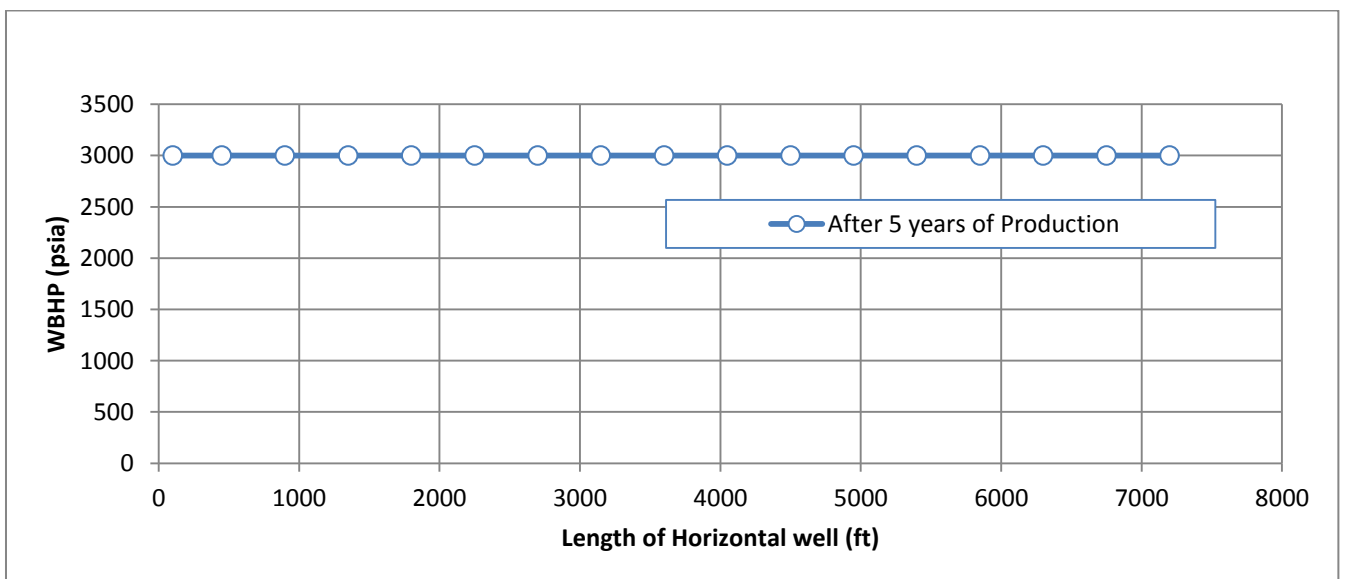

*Fig10.3 Field Well Bottom hole flowing pressure for Case-1(a)*

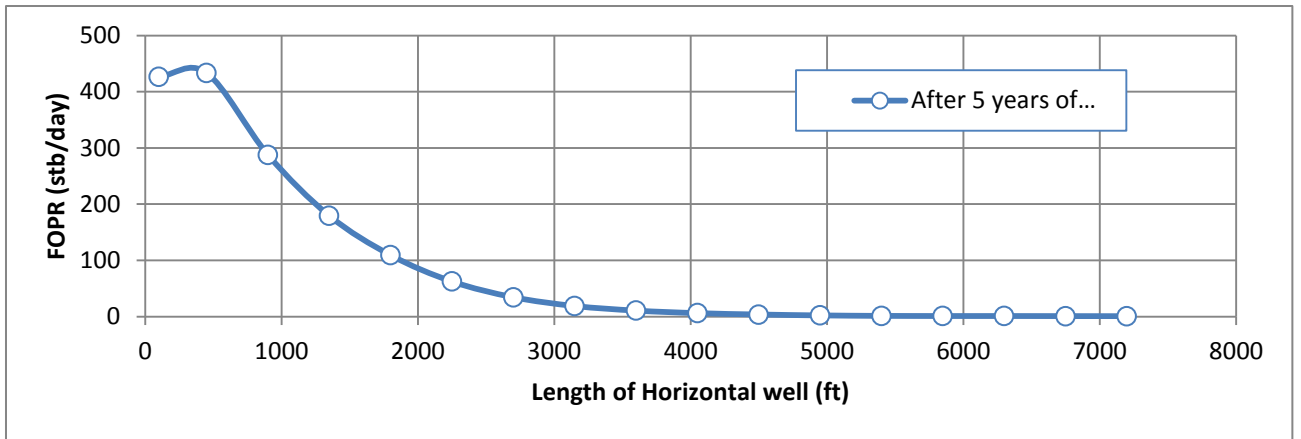

Fig10.4 Oil well Production Rate for Case-1(b)

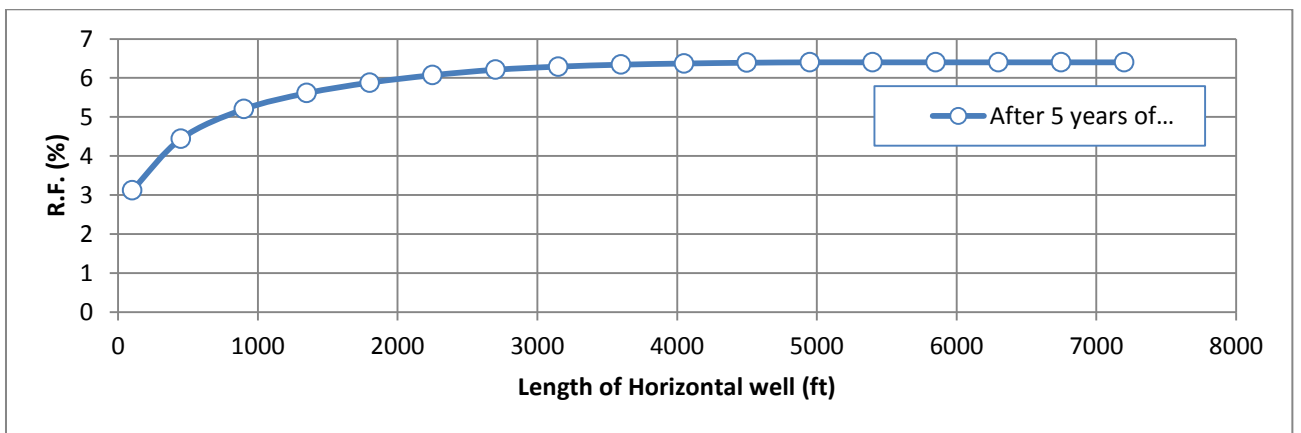

Fig10.5 Oil Recovery Factor for Case-1(b)

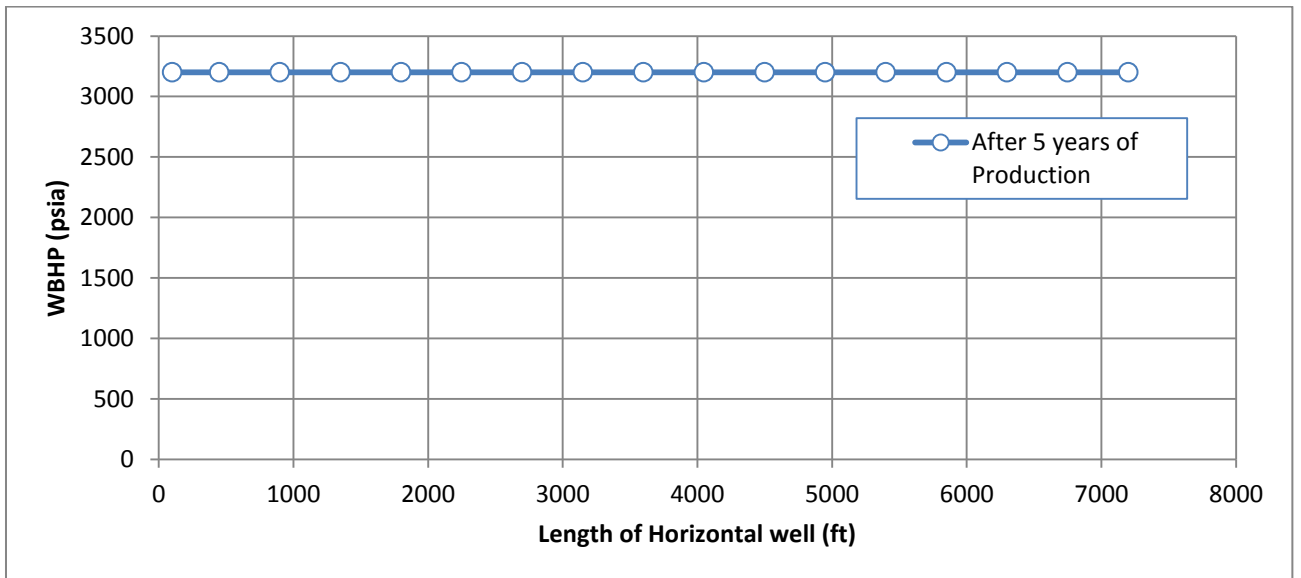

Fig10.6 Field Well Bottom hole flowing pressure for Case-1(b)

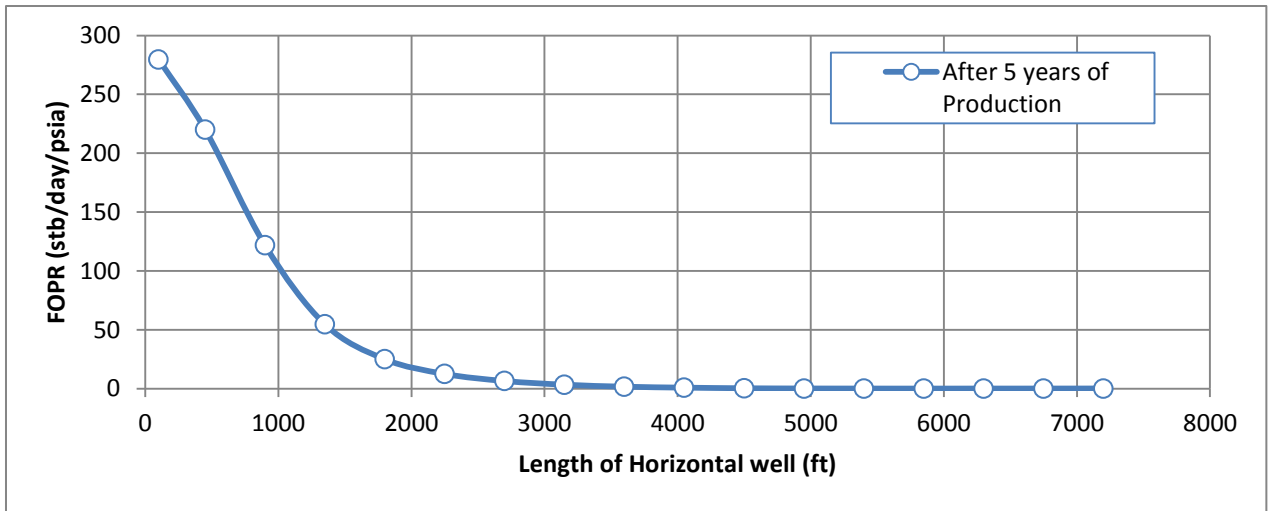

Fig10.7 Oil well Production Rate for Case-1(c)

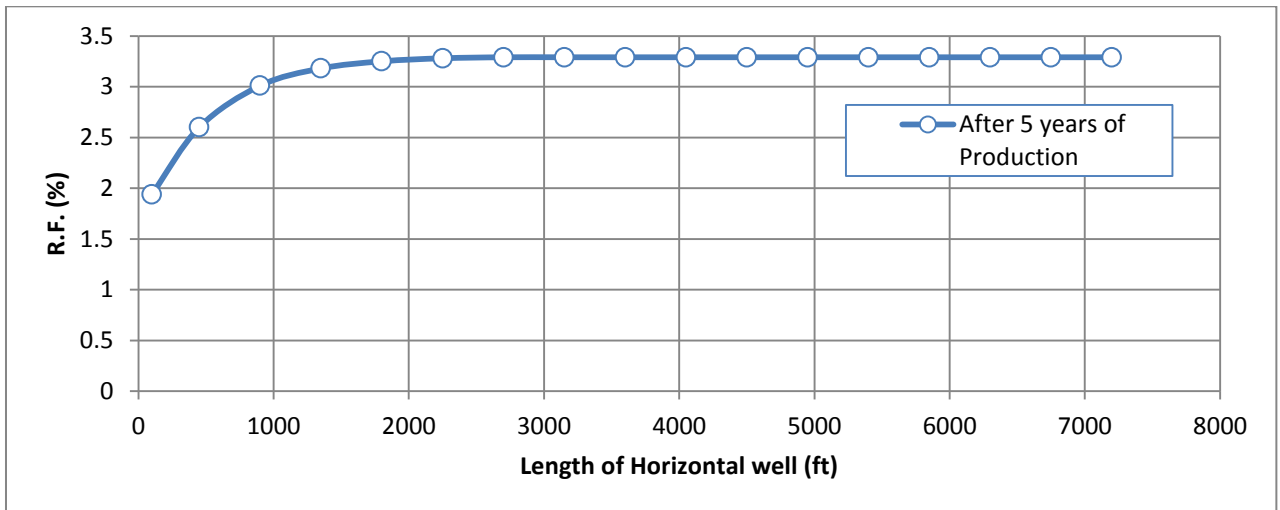

Fig10.8 Oil Recovery Factor for Case-1(c)

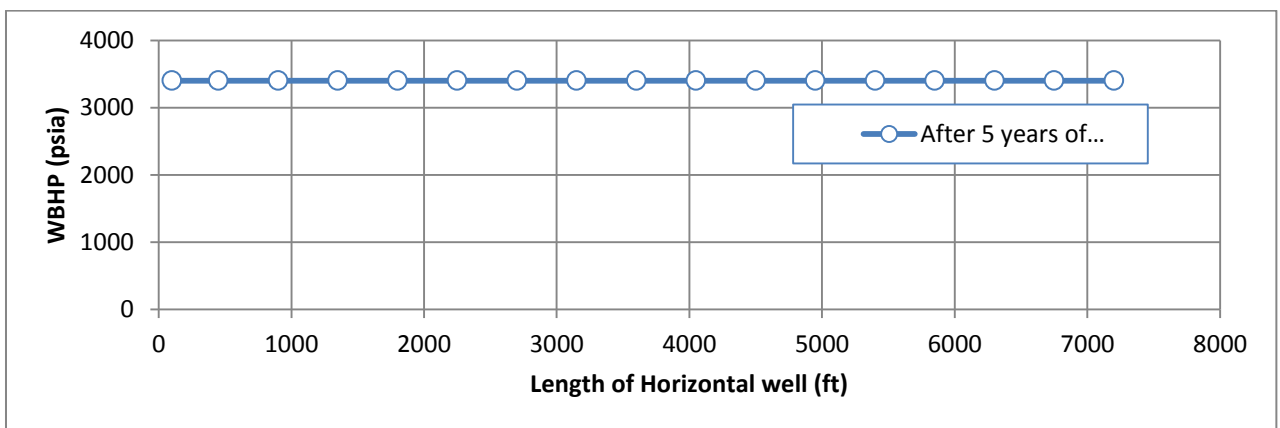

Fig10.9 Field Well Bottom hole flowing pressure for Case-1(c)

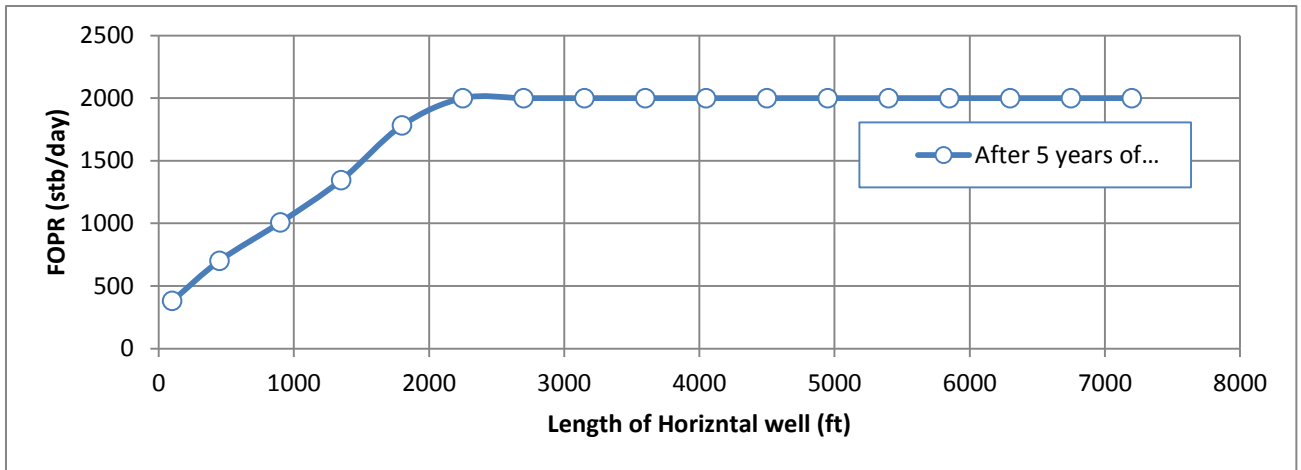

Fig10.10 Oil well Production Rate for Case-2(a)

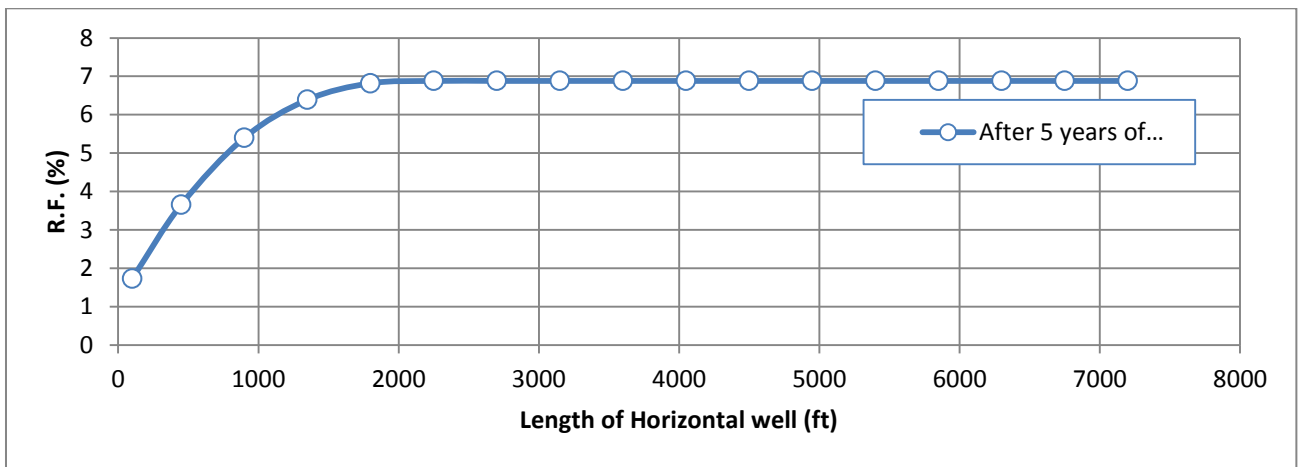

Fig10.11 Oil Recovery Factor for Case-2(a)

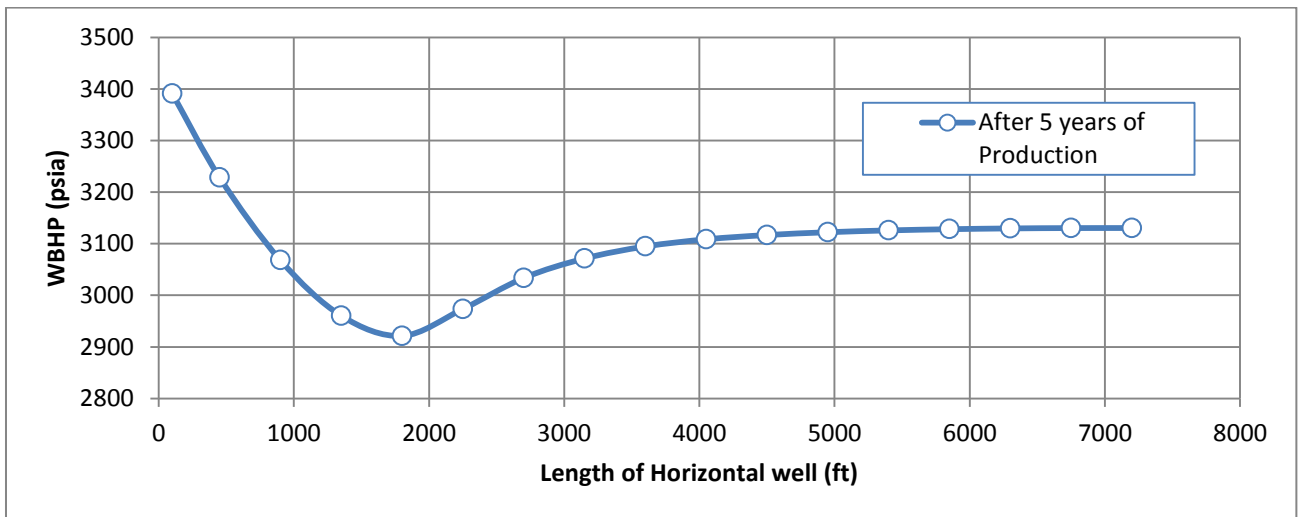

Fig10.12 Field Well Bottom hole flowing pressure for Case-2(a)

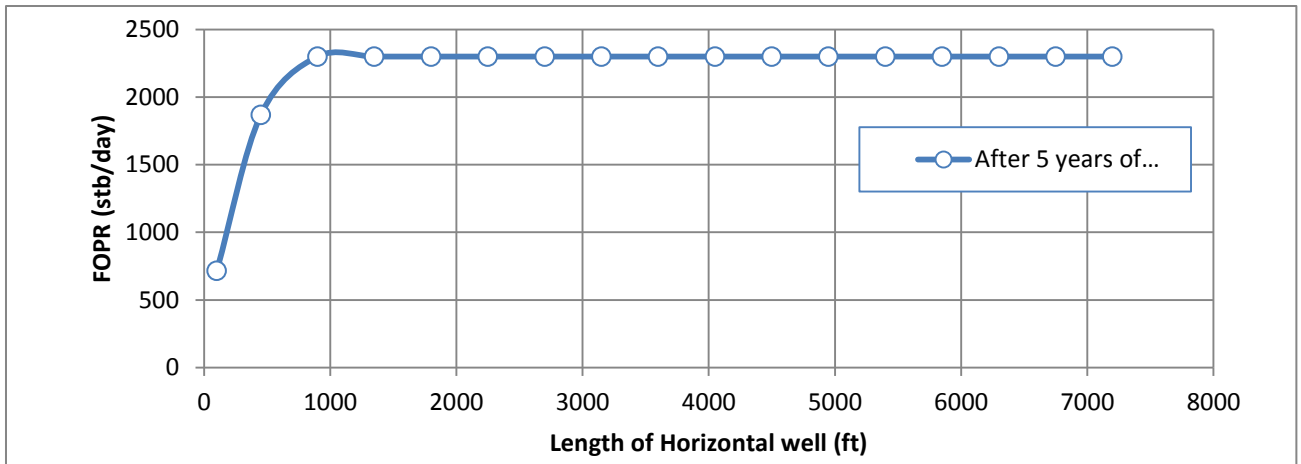

Fig10.13 Oil well Production Rate for Case-2(b)

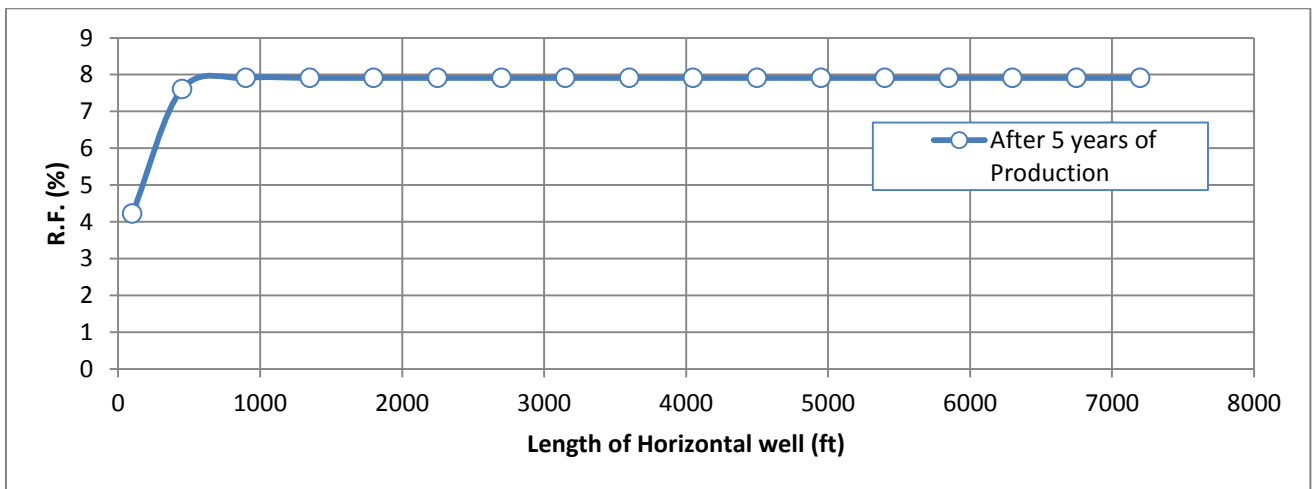

Fig10.14 Oil Recovery Factor for Case-2(b)

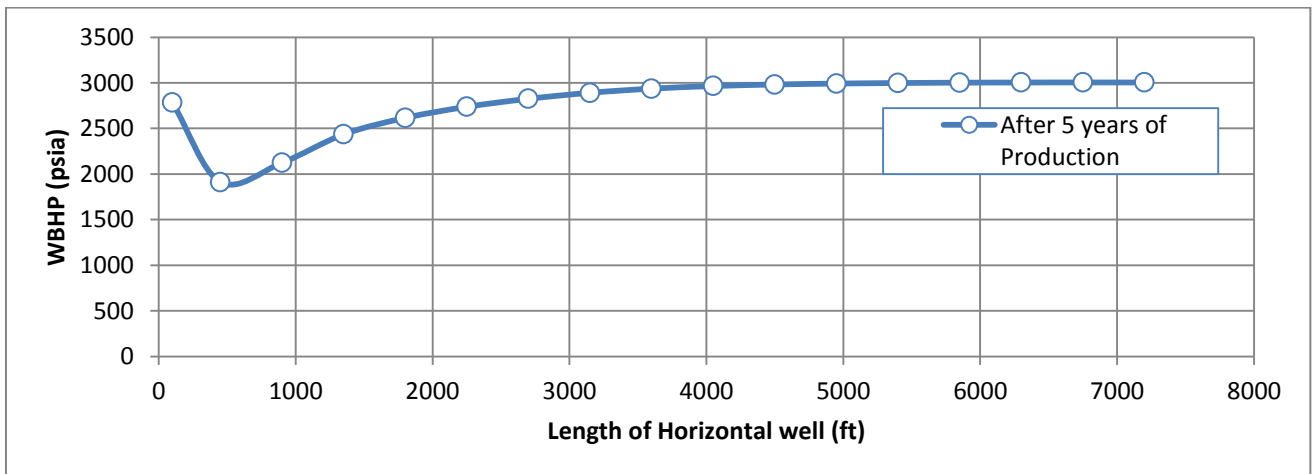

Fig10.15 Field Well Bottom hole flowing pressure for Case-2(b)



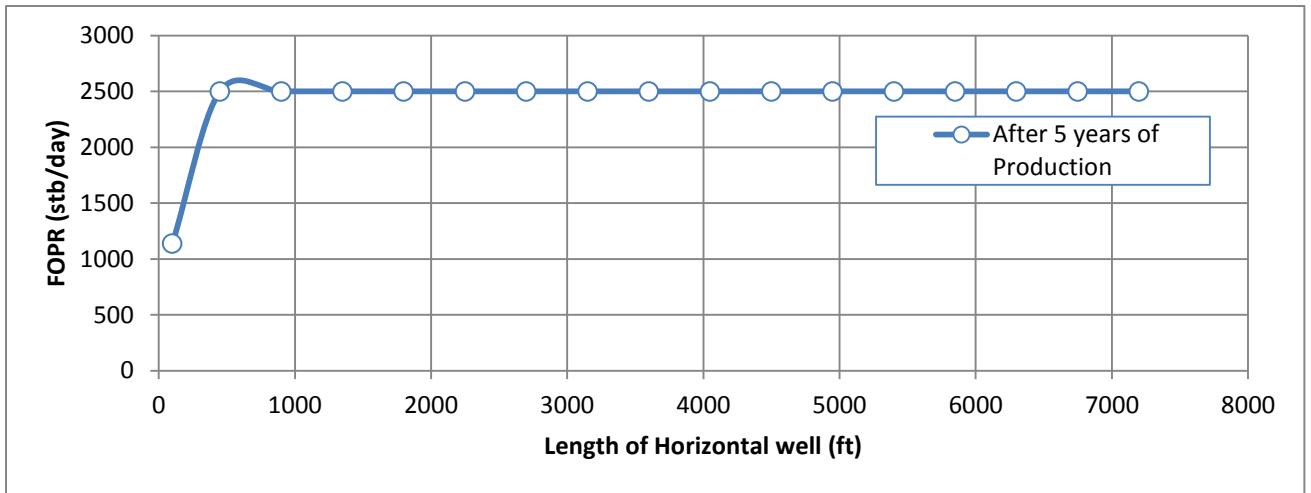

Fig10.16 Oil well Production Rate for Case-2(c)

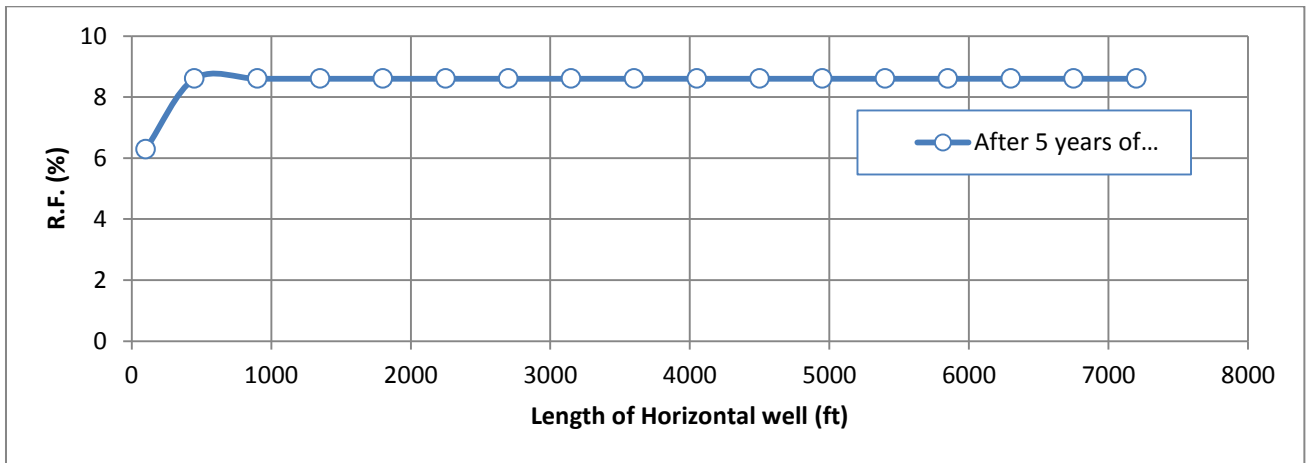

Fig10.17 Oil Recovery Factor for Case-2(c)

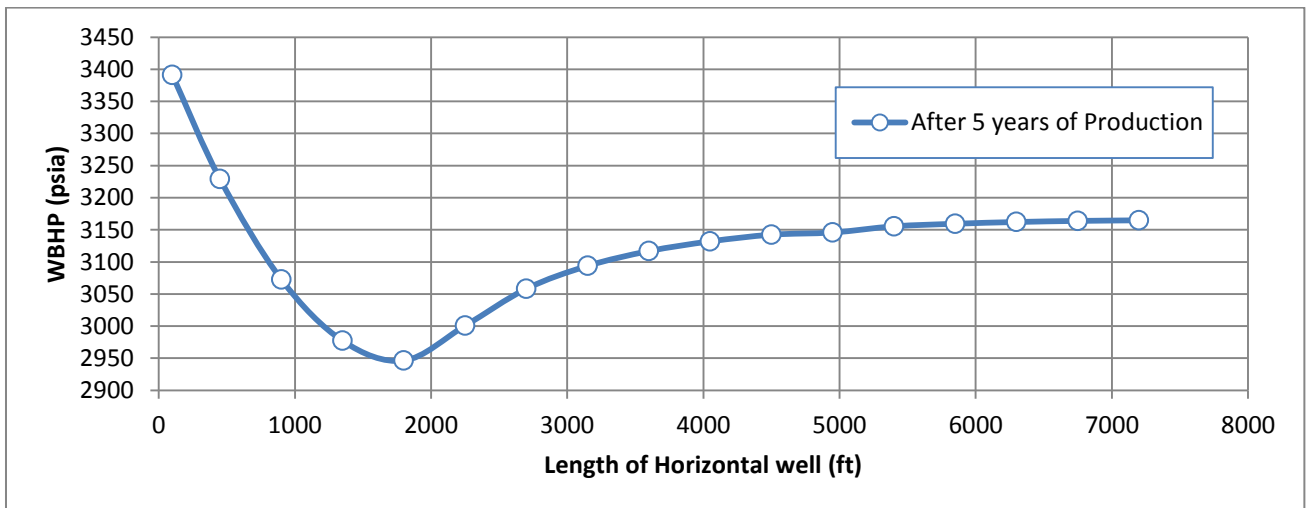

Fig10.18 Field Well Bottom hole flowing pressure for Case-2(c)

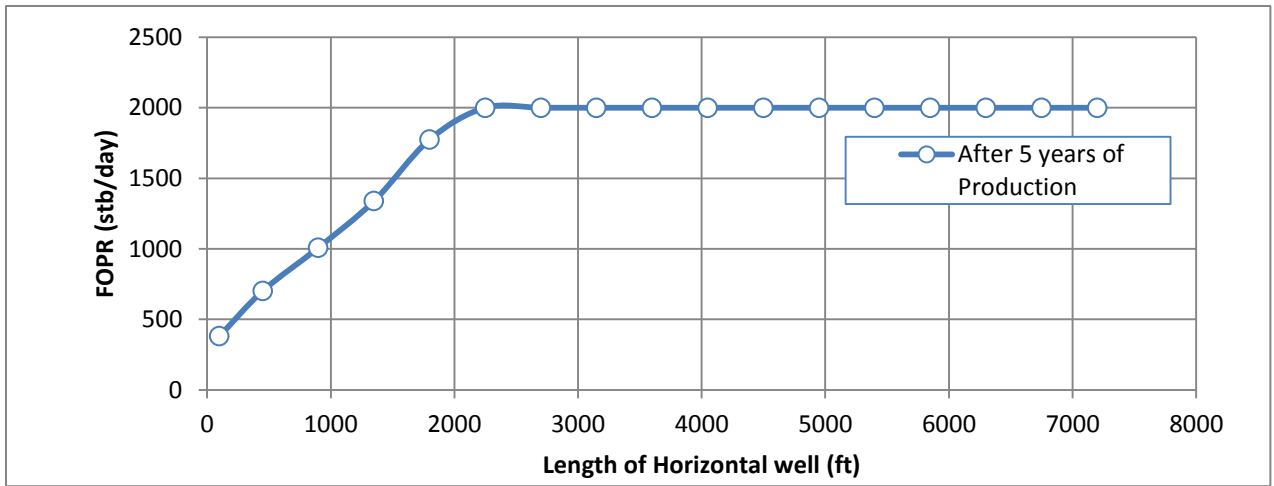

Fig10.19 Oil well Production Rate for Case-3(a)

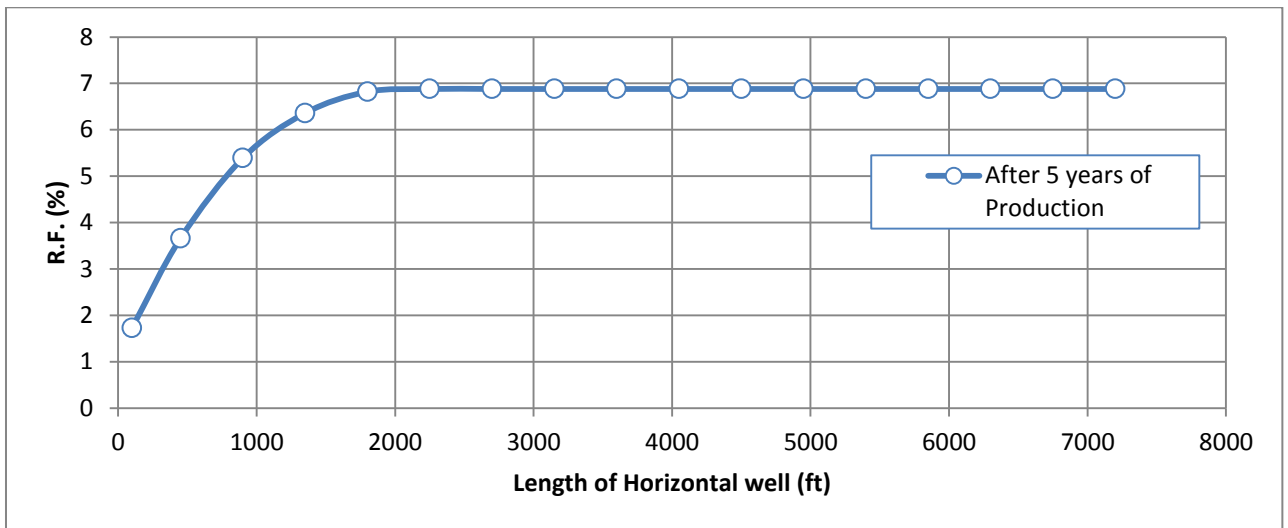

Fig10.20 Oil Recovery Factor for Case-3(a)

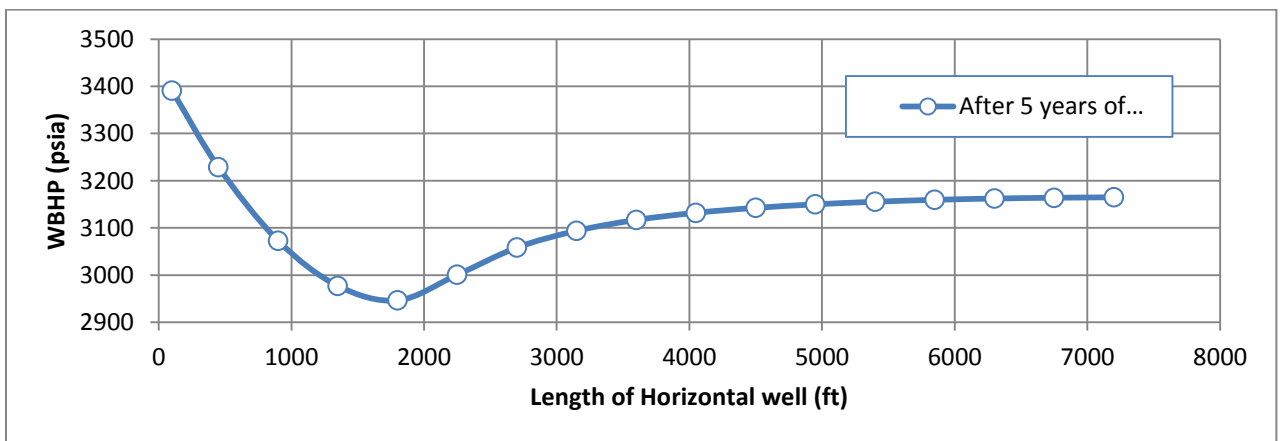

Fig10.21 Field Well Bottom hole flowing pressure for Case-3(a)

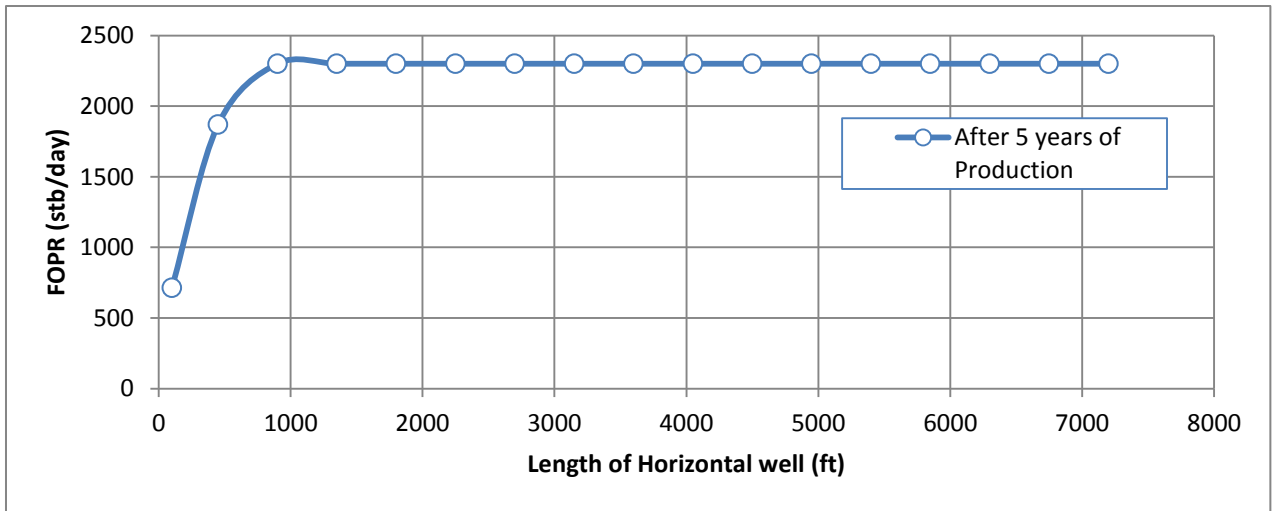

Fig10.22 Oil well Production Rate for Case-3(b)

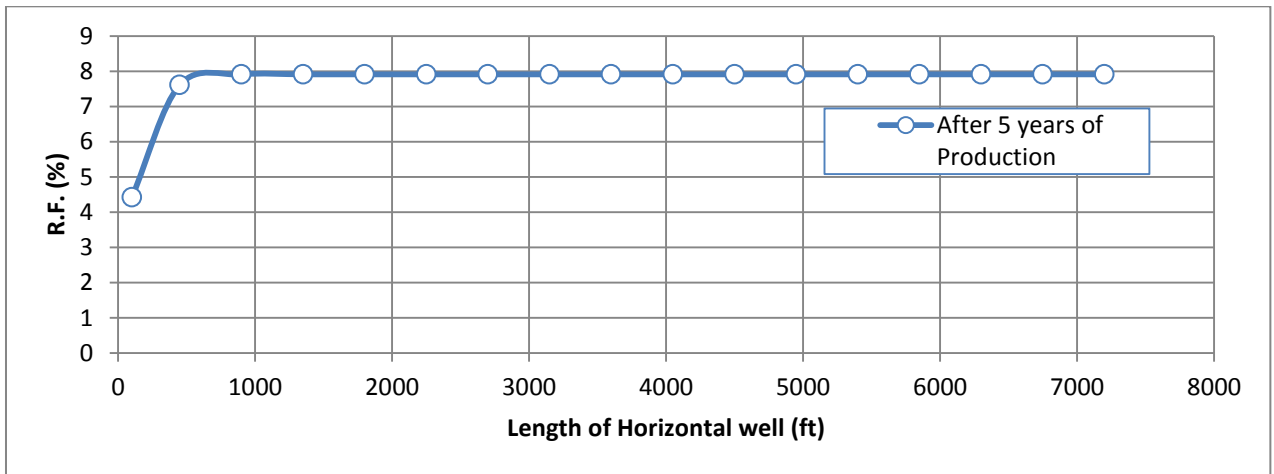

Fig10.23 Oil Recovery Factor for Case-3(b)

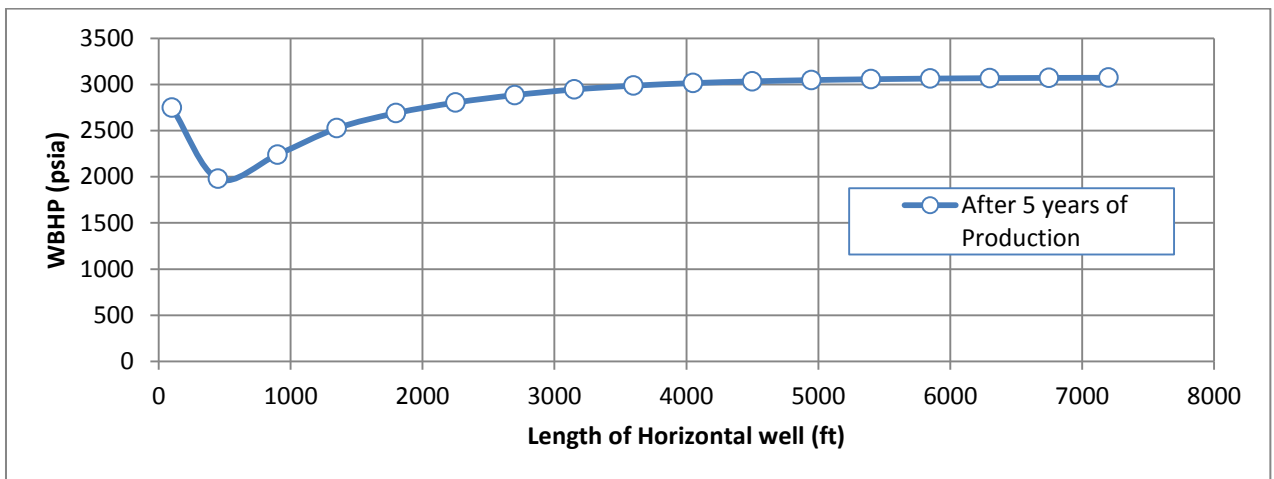

Fig10.24 Field Well Bottom hole flowing pressure for Case-3(b)

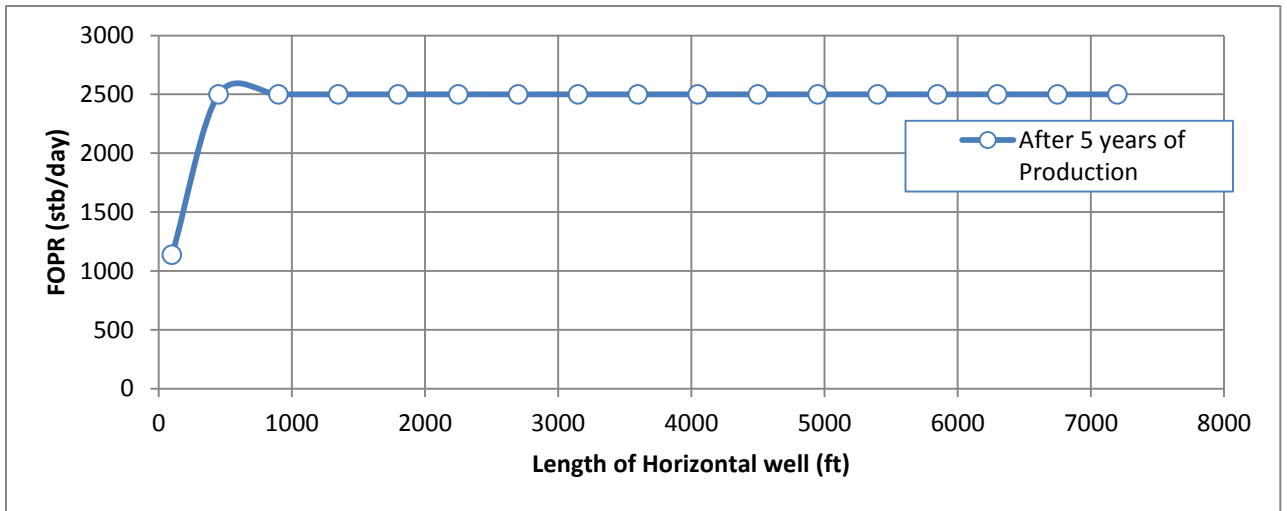

Fig10.25 Oil well Production Rate for Case-3(c)

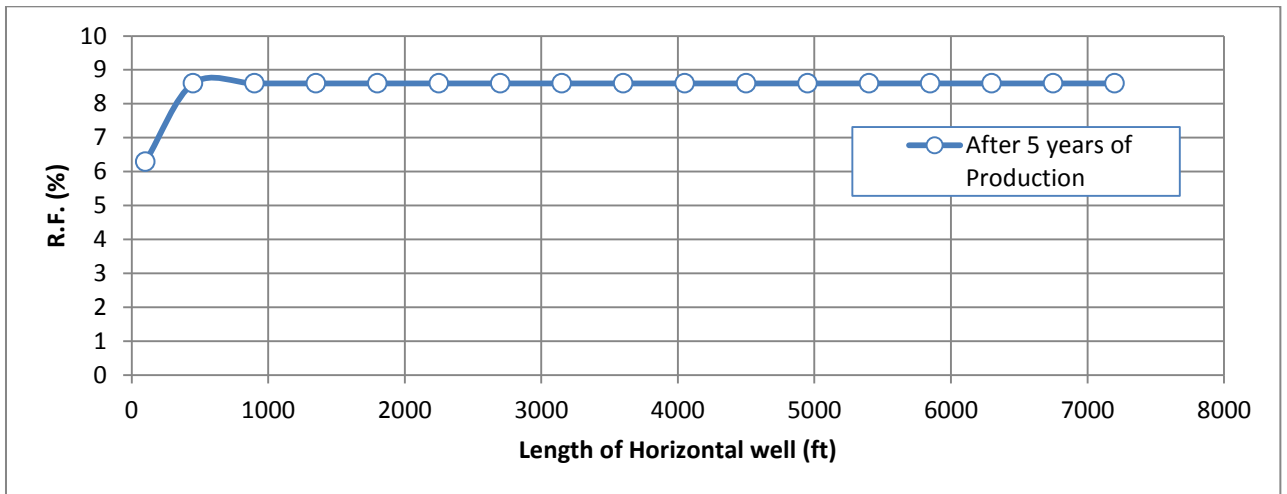

Fig10.26 Oil Recovery Factor for Case-3(c)

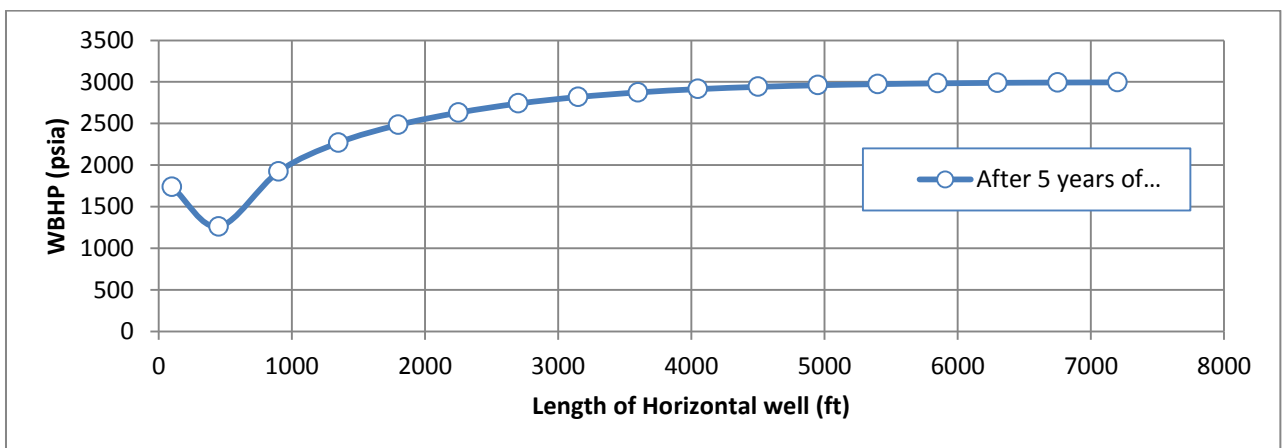

Fig10.27 Field Well Bottom hole flowing pressure for Case-3(c)

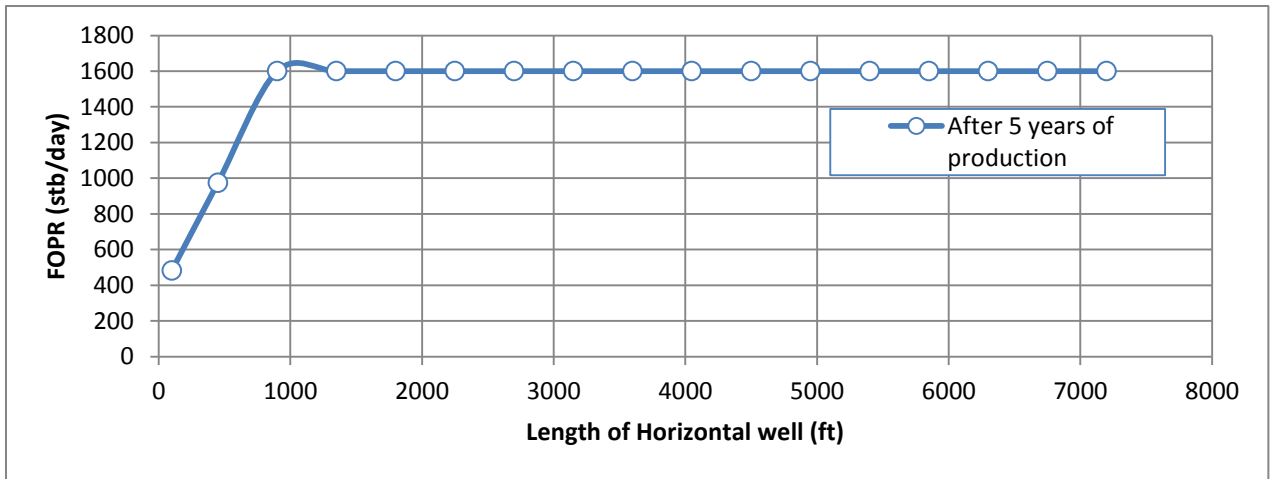

Fig10.28 Oil well Production Rate for Case-4(a)

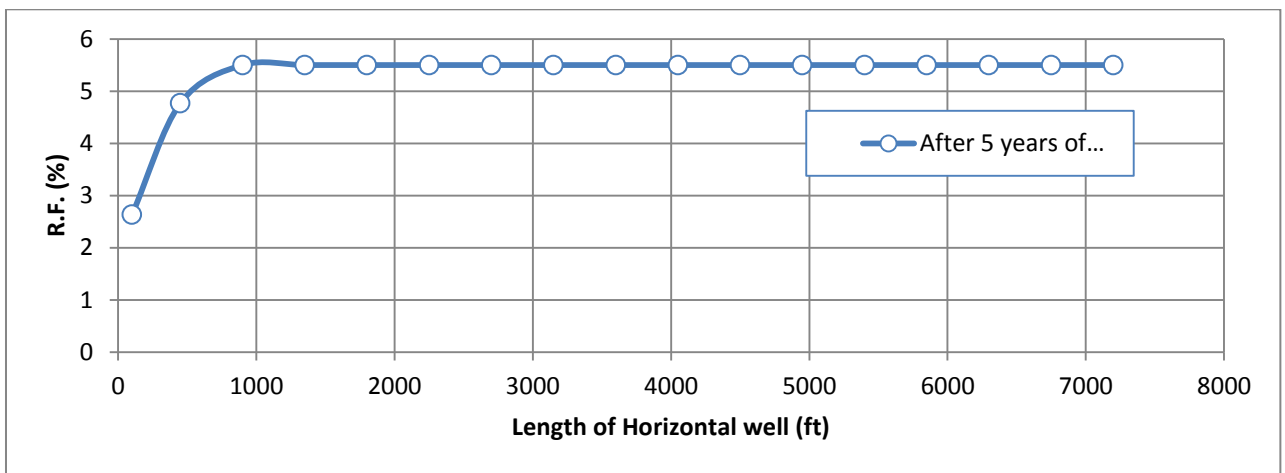

Fig10.29 Oil Recovery Factor for Case-4(a)

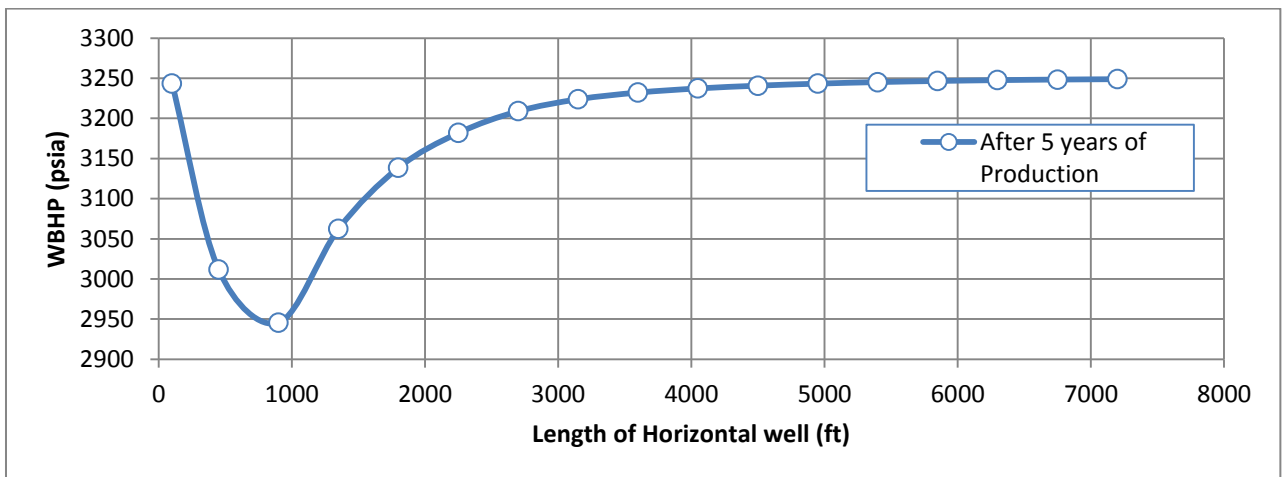

Fig10.30 Field Well Bottom hole flowing pressure for Case-4(a)

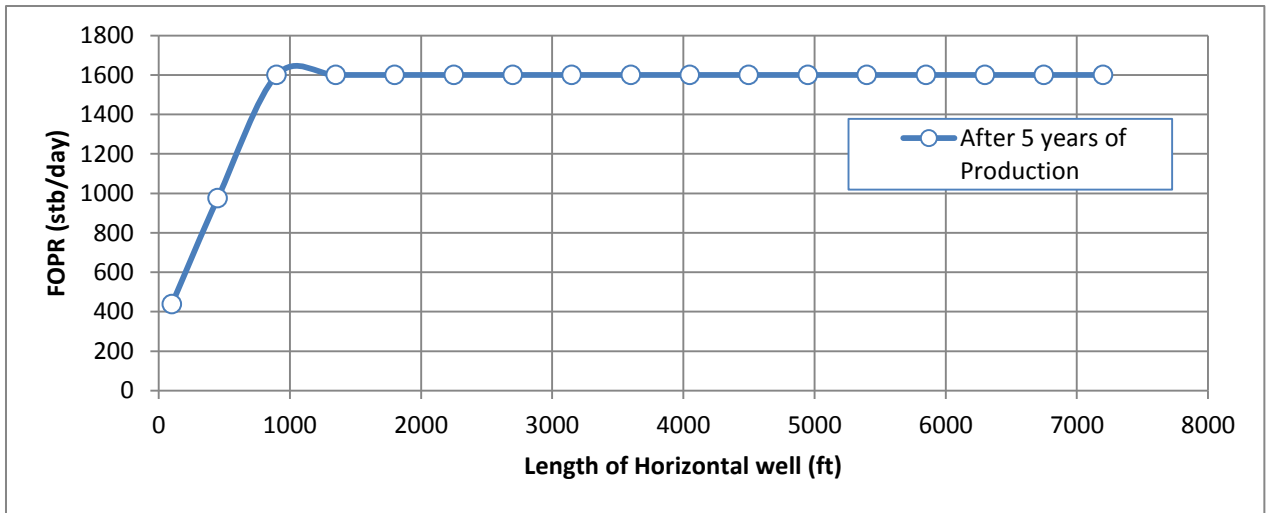

Fig10.31 Oil well Production Rate for Case-4(b)

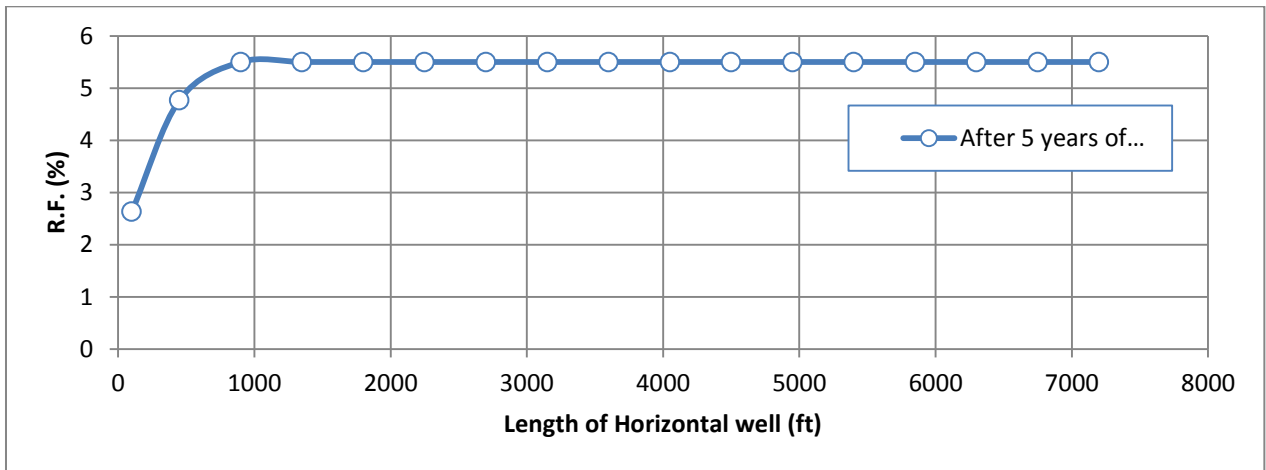

Fig10.32 Oil Recovery Factor for Case-4(b)

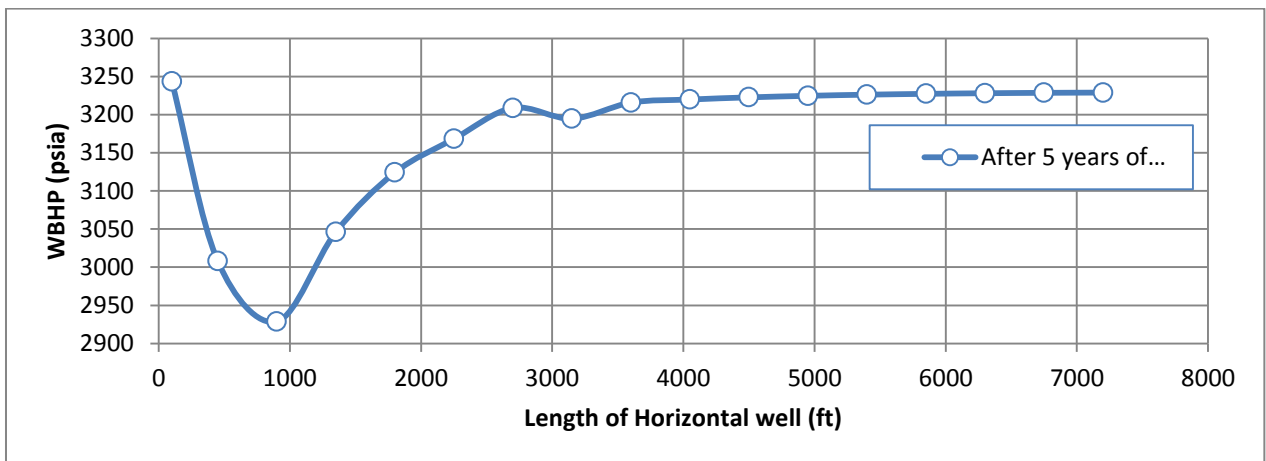

Fig10.33 Field Well Bottom hole flowing pressure for Case-4(b)

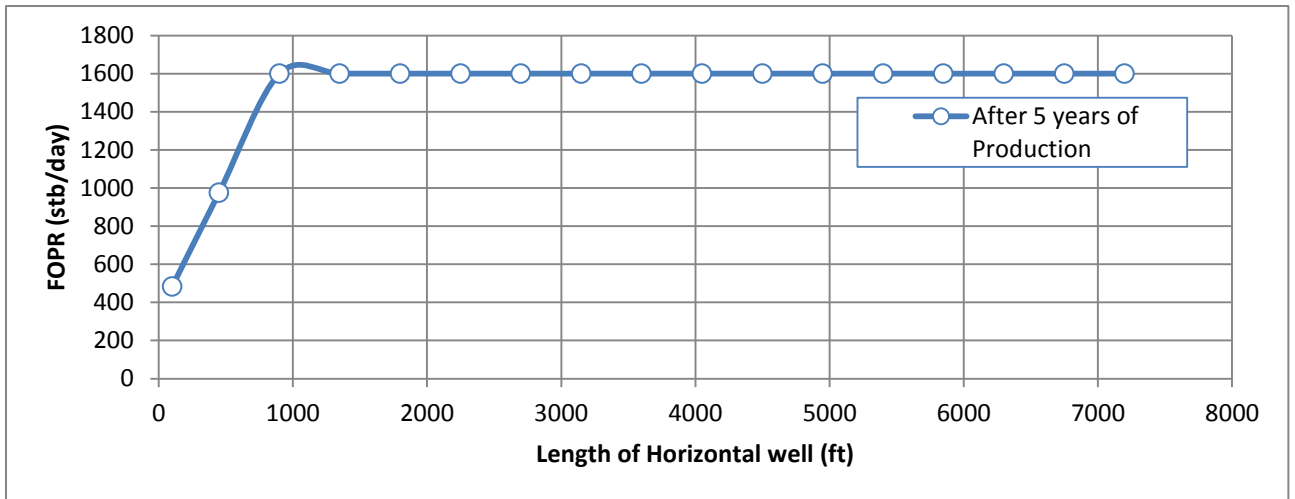

Fig10.34 Oil well Production Rate for Case-4(c)

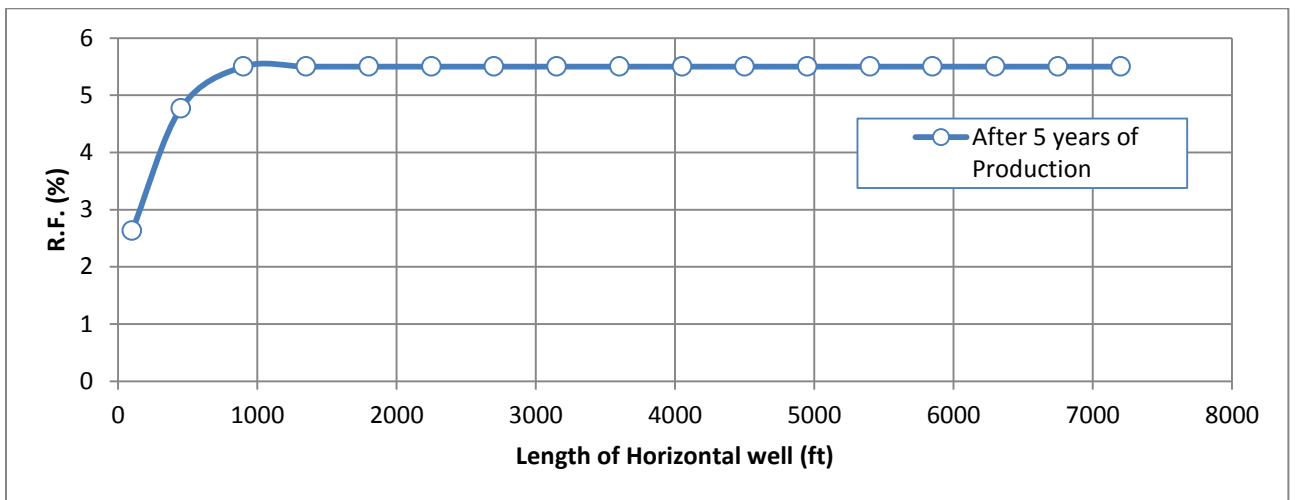

Fig10.35 Oil Recovery Factor for Case-4(c)

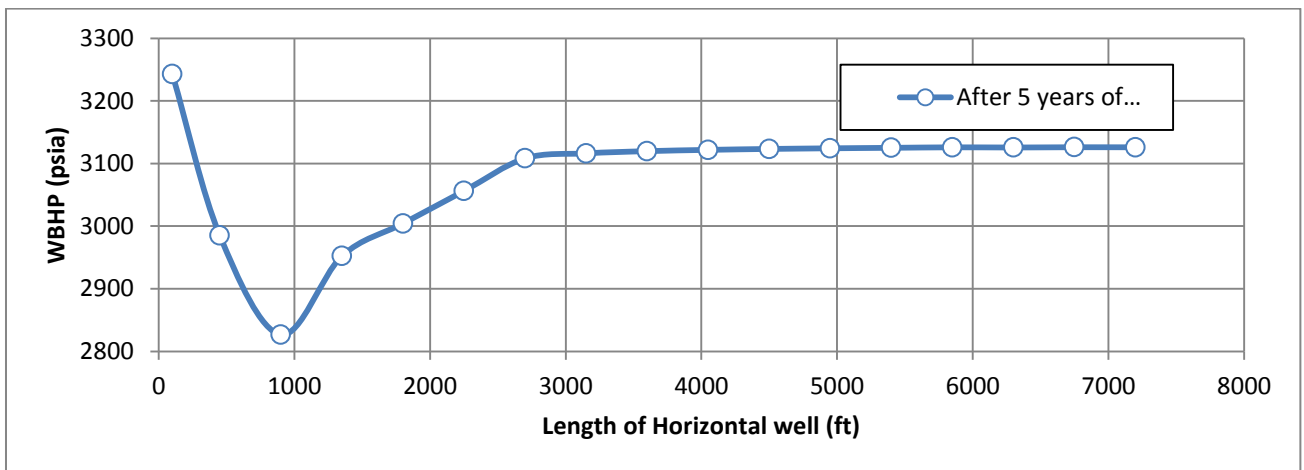

Fig10.36 Field Well Bottom hole flowing pressure for Case-4(c)

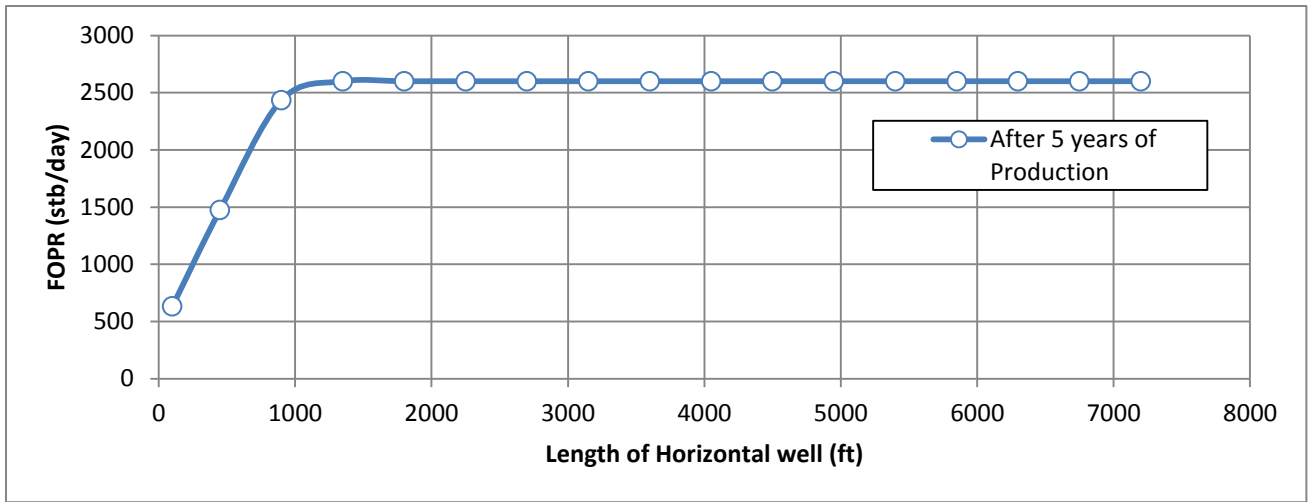

Fig10.37 Oil well Production Rate for Case-5(a)

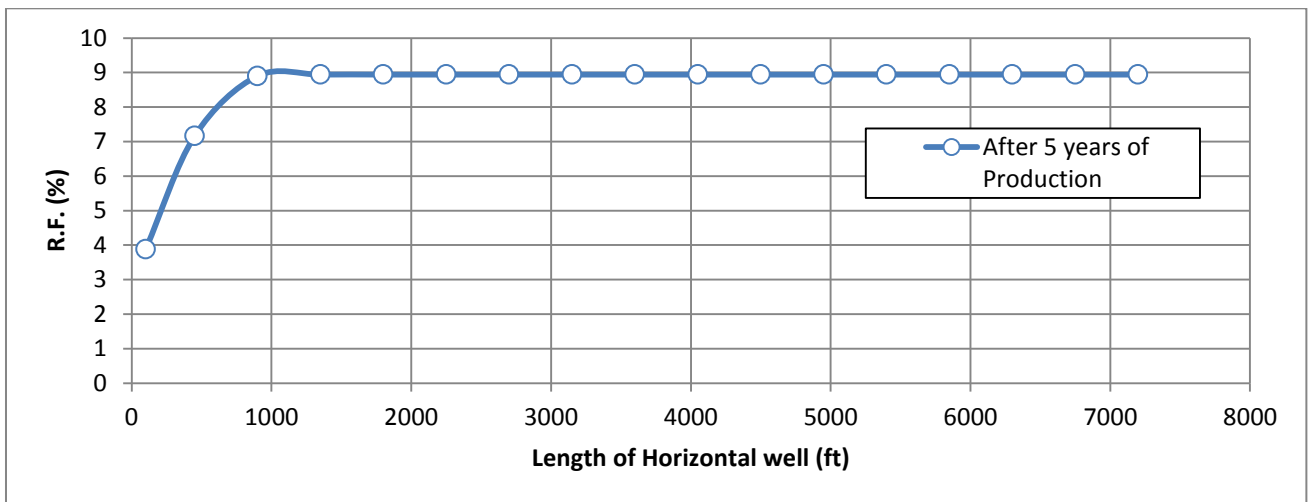

Fig10.38 Oil Recovery Factor for Case-5(a)

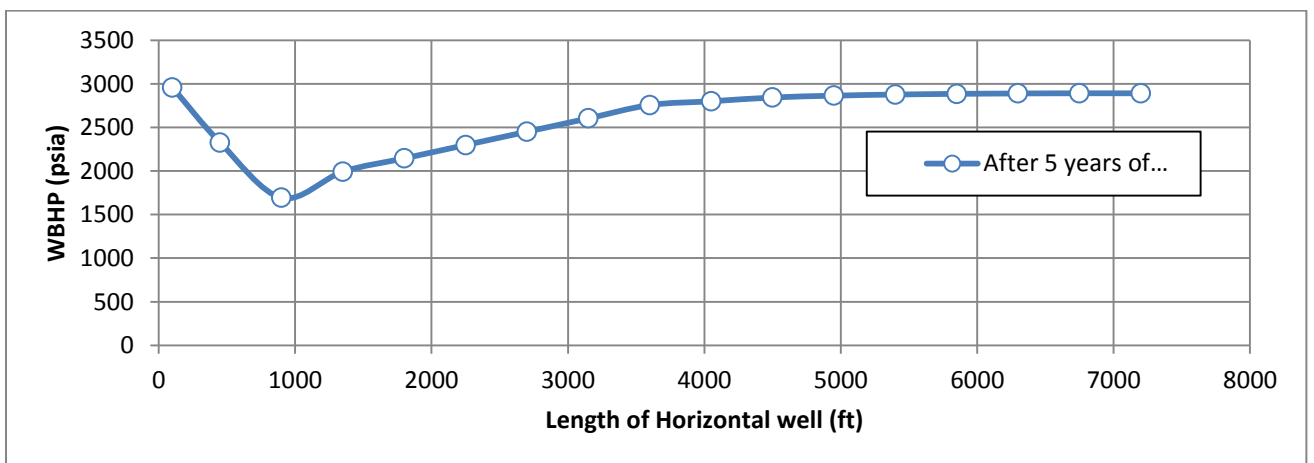

Fig10.39 Field Well Bottom hole flowing pressure for Case-5(a)



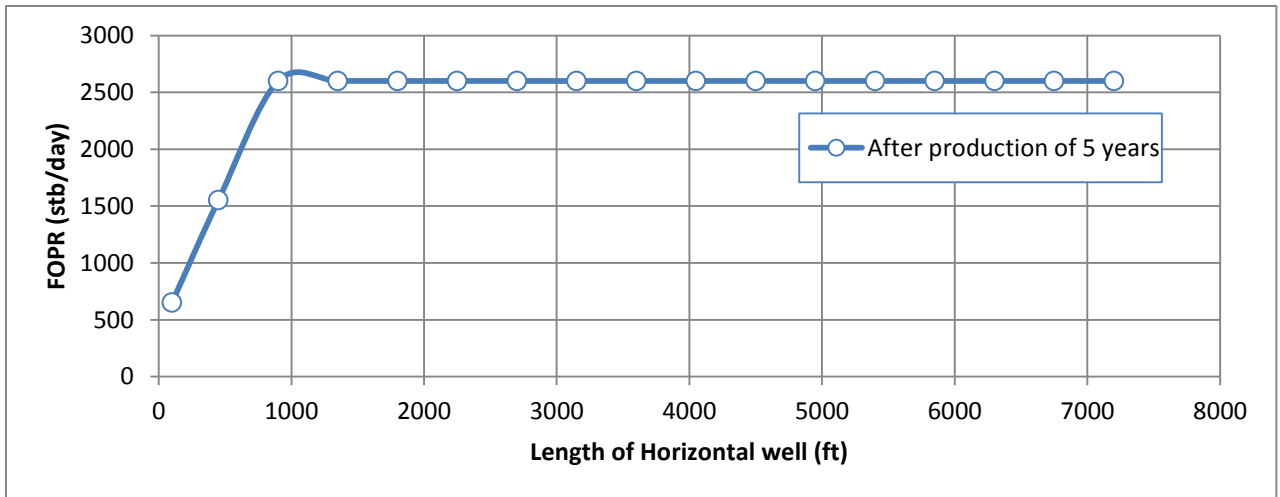

Fig10.40 Oil well Production Rate for Case-5(b)

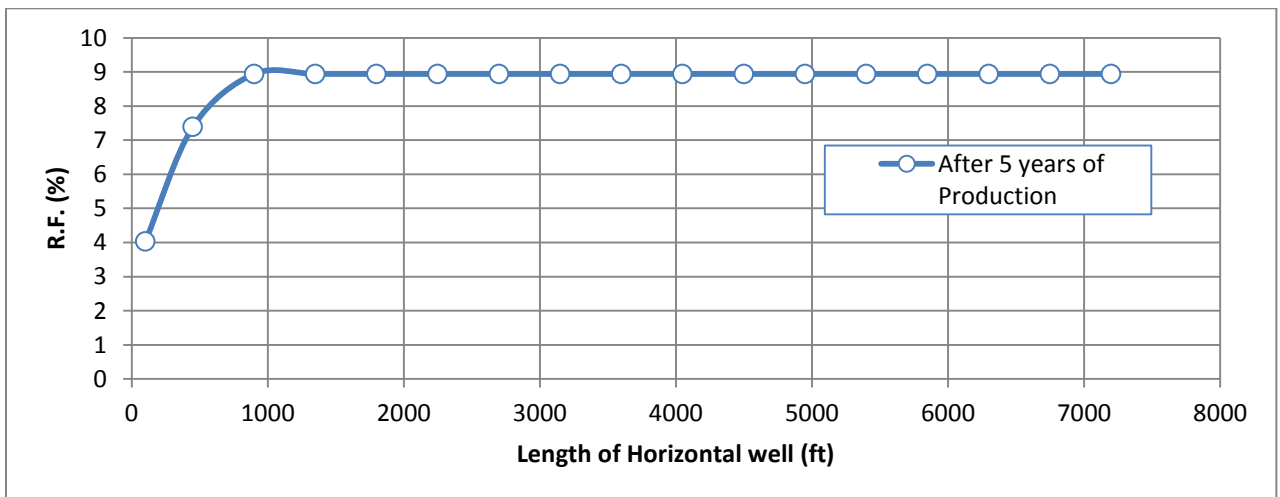

Fig10.41 Oil Recovery Factor for Case-5(b)

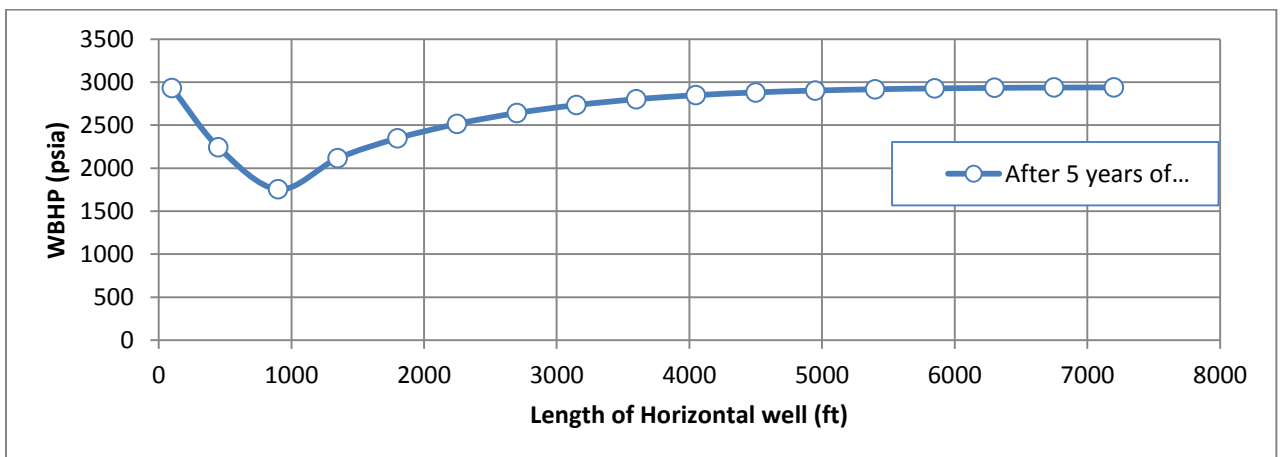

Fig10.42 Field Well Bottom hole flowing pressure for Case-5(b)

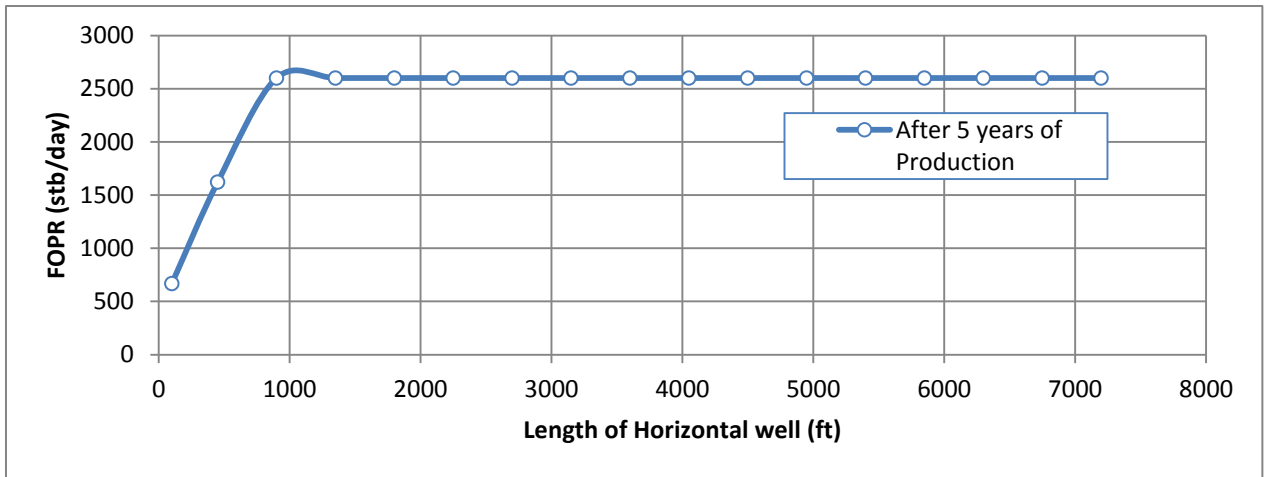

Fig10.43 Oil well Production Rate for Case-5(c)

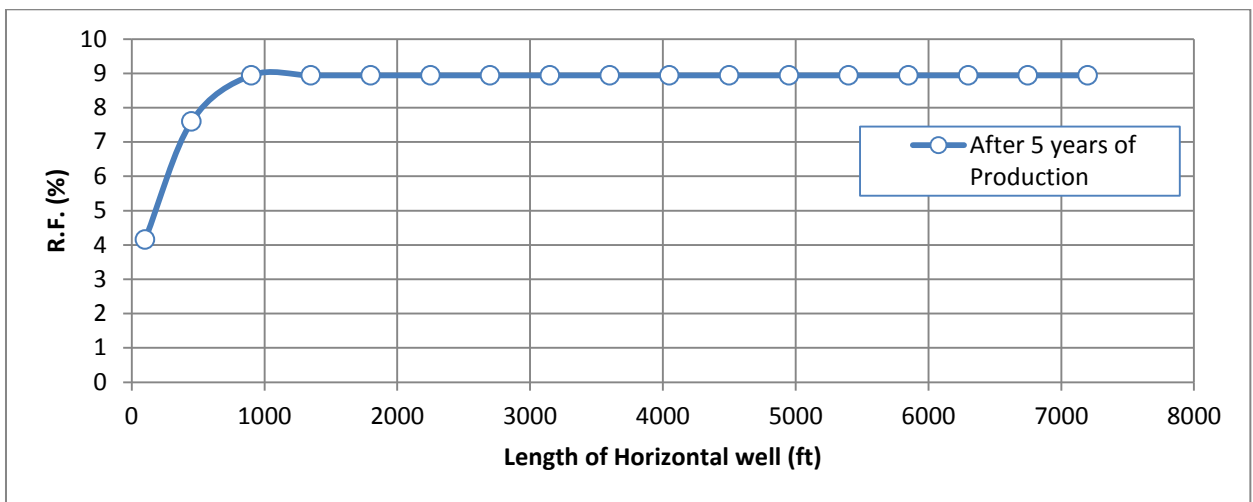

Fig10.44 Oil Recovery Factor for Case-5(c)

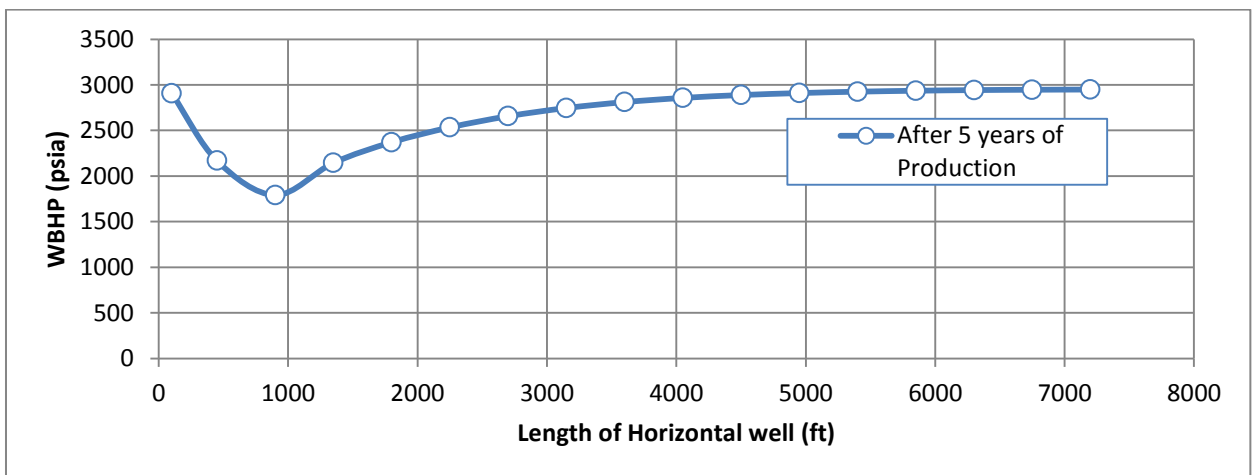

Fig10.45 Field Well Bottom hole flowing pressure for Case-5(c)

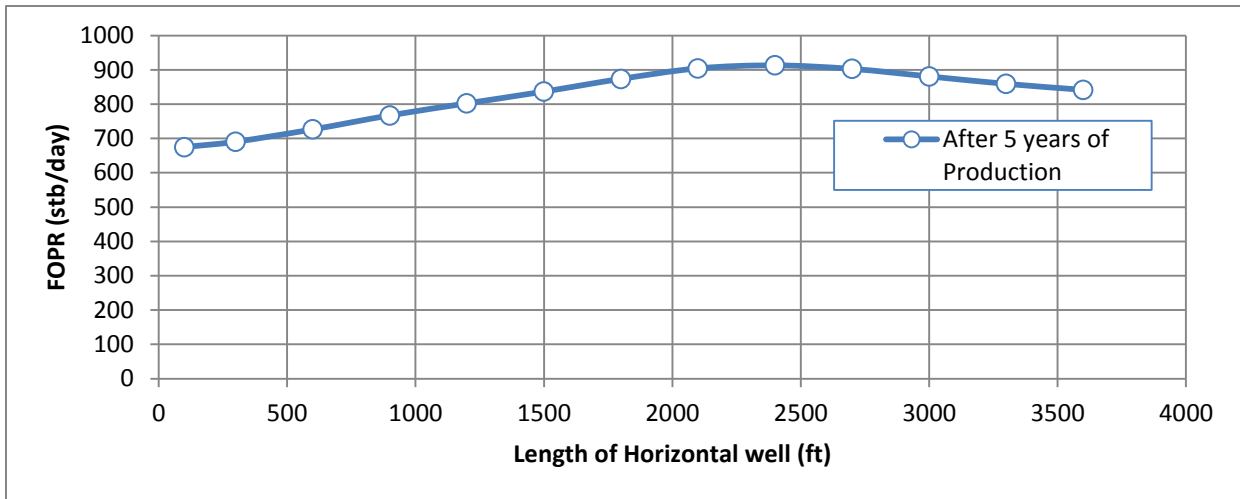

Fig10.46 Oil well Production Rate for Case-6(a)

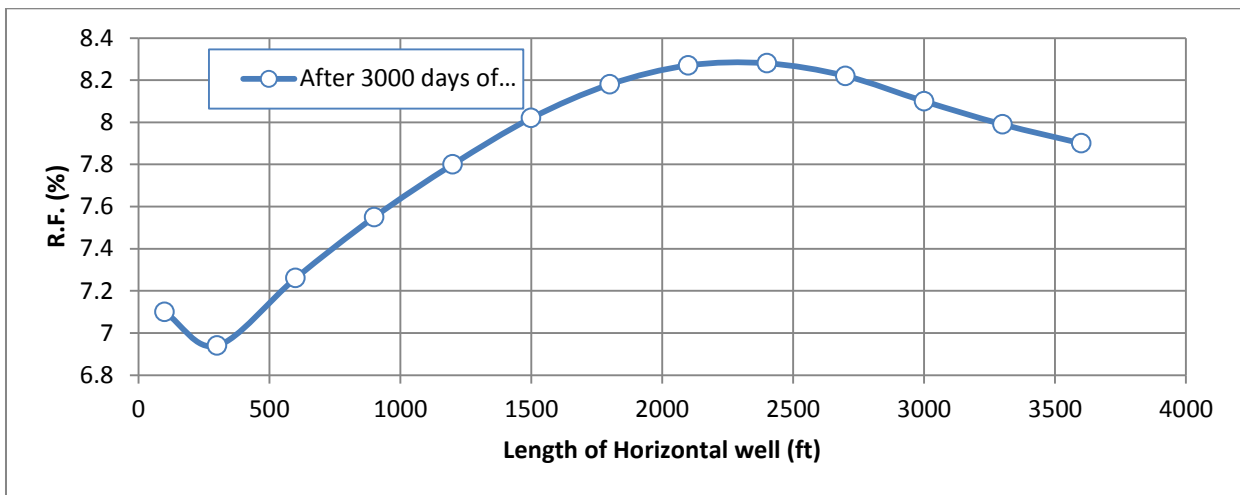

Fig10.47 Oil Recovery Factor for Case-6(a)

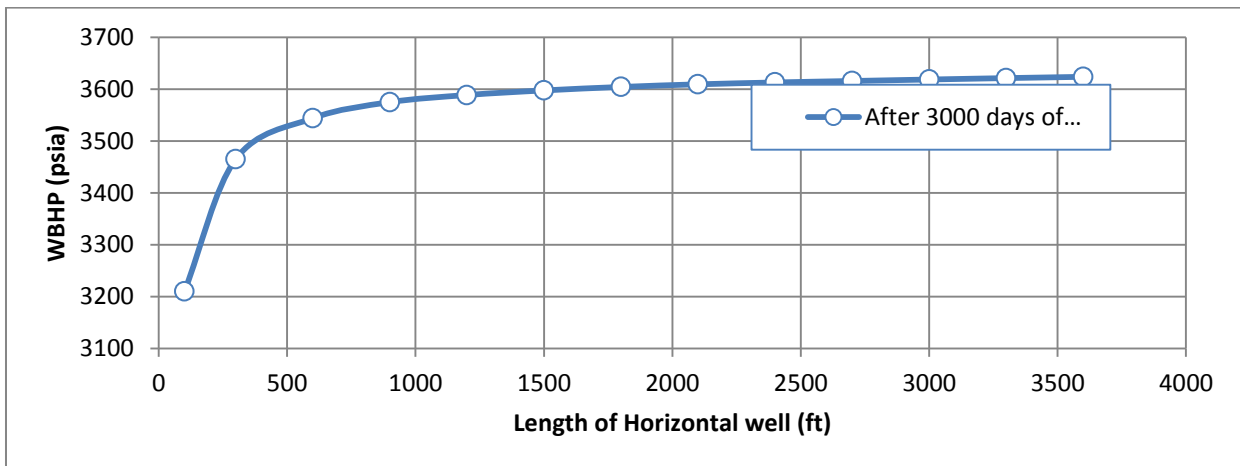

Fig10.48 Field Well Bottom hole flowing pressure for Case-6(a)

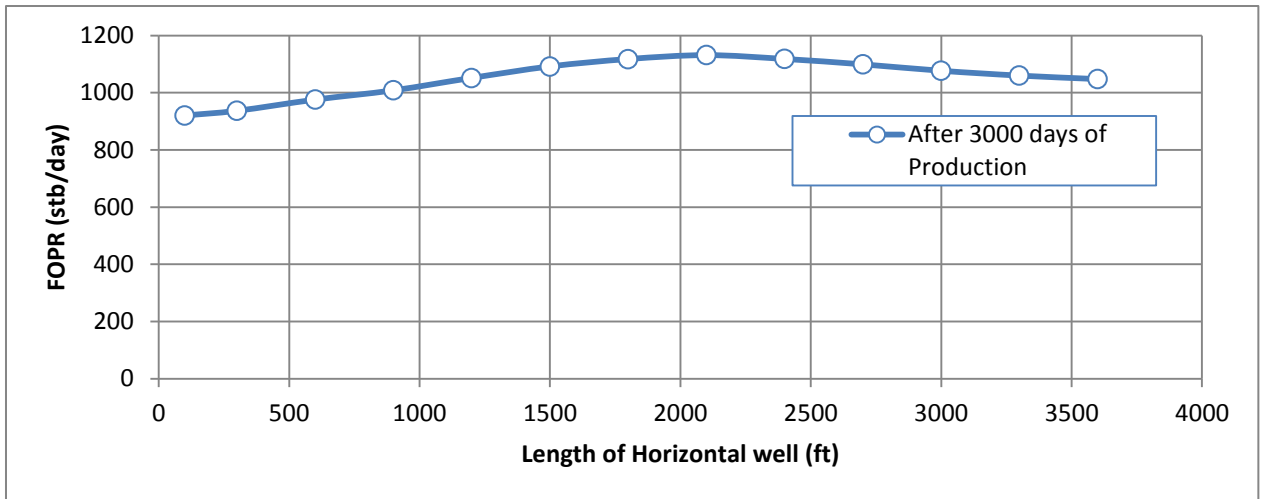

Fig10.49 Oil well Production Rate for Case-6(b)

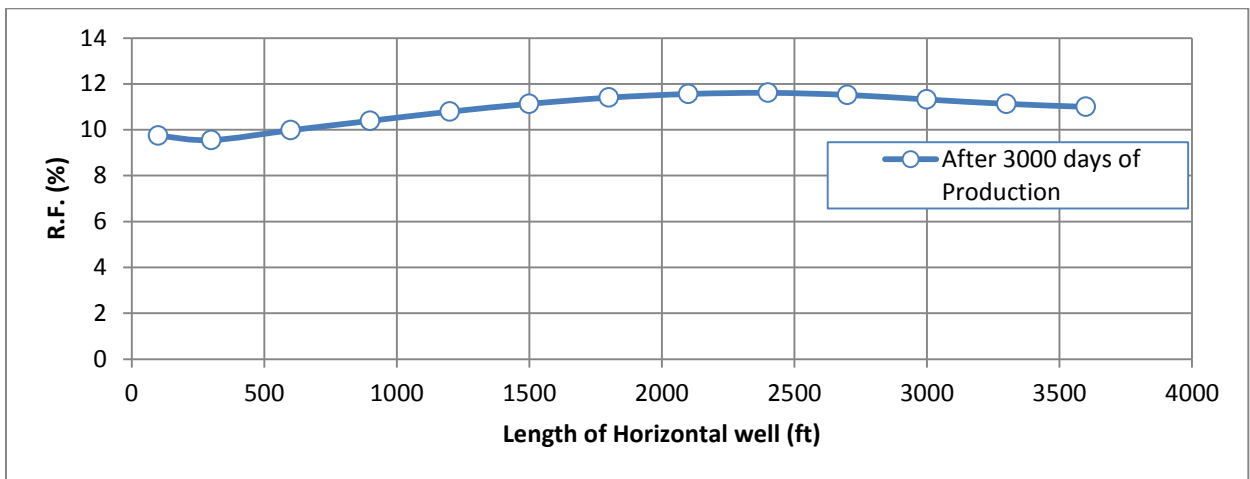

Fig10.50 Oil Recovery Factor for Case-6(b)

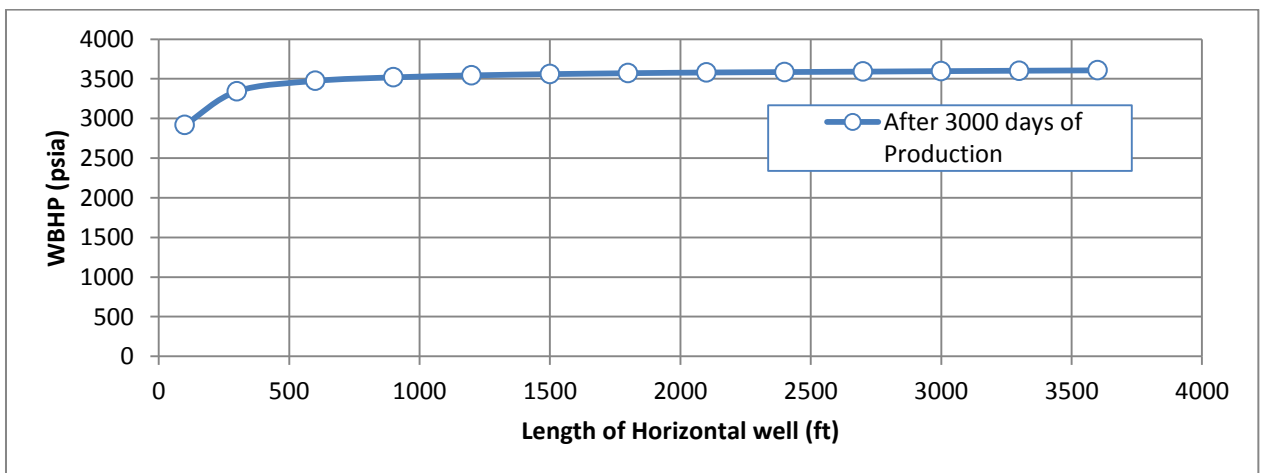

Fig10.51 Field Well Bottom hole flowing pressure for Case-6(b)

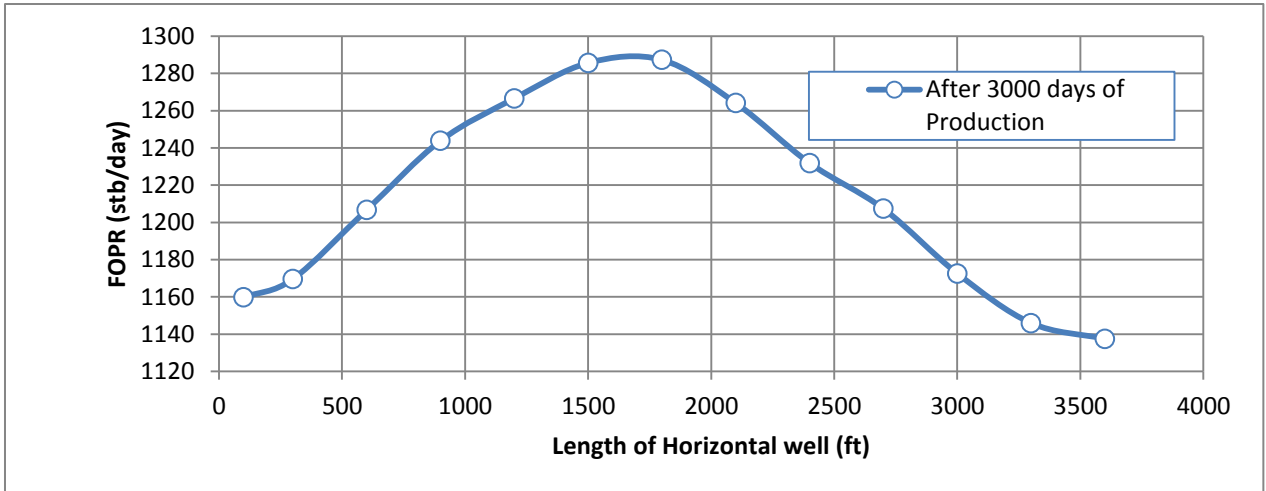

Fig10.52 Oil well Production Rate for Case-6(c)

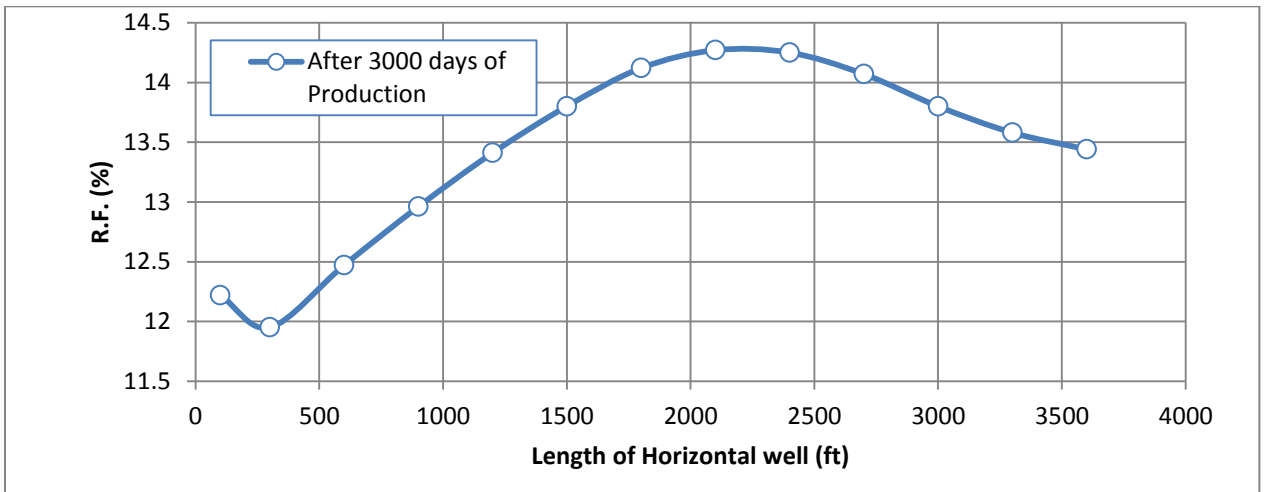

Fig10.53 Oil Recovery Factor for Case-6(c)

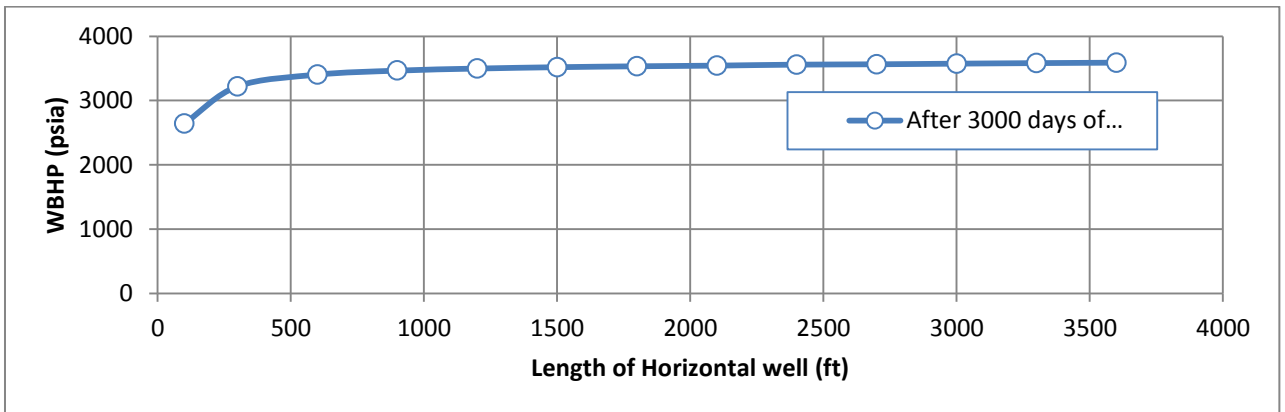

Fig10.54 Field Well Bottom hole flowing pressure for Case-6( c)

