



Norwegian University of
Science and Technology

Risk Modeling of DP Operation for Offshore Tandem Offloading

Shunan Zhao

Marine Technology

Submission date: June 2016

Supervisor: Jan Erik Vinnem, IMT

Norwegian University of Science and Technology
Department of Marine Technology

Zhao Shunan

Risk Modeling of DP Operation for Offshore Tandem Offloading

Trondheim 16. 12. 2015

Supervisor: Jan Erik Vinnem

Norwegian University of Science Technology

Faculty of Engineering Science and Technology

Department of Marine Technology



NTNU – Trondheim
Norwegian University of
Science and Technology

Abstract

The paper proposes a risk model to warn shuttle tanker drive-off previously and detect it punctually, and proposes a risk decision support model to generate, evaluate and select a best vessel maneuvering plan to avoid the shuttle tanker collision with FPSO. The central concern is to establish an Online Decision Support System to collect and analyze the real-time data by these two models, so as to help the drive-off vessel recovered successfully.

Fault Tree Analysis is used to find the root causes to detect the vessel drive-off. Event Tree Analysis is used to evaluate and compare the different risk pictures of shuttle tanker and FPSO layout. Bayesian Risk Influence Diagram is used to generate maneuvering plans. In addition, the system deploys vessel collision consequence model and vessel collision probability model to evaluate the plans.

A Human Machine Interface is designed to provide a viewable screen about operation information. In addition, a contingency plan for drive-off recovery and position reference selection procedure are generated for daily operation.

Preface

This thesis has been written as a master thesis program on Marine Operation at the Department of Marine Technology, Norwegian University of Science and Technology (NTNU),

I would like to thank my supervisor, Professor Jan Erik Vinnem, at the Department of Marine Technology, NTNU, for the dedicated support and valuable feedback on my work with this thesis.

Thanks for the Ship Modeling& Simulation& Center providing two-week education and valuable input on DP operation and Emergency Operation from course instructor Mr. Jan-Igen Adverdsen and Gunner Gudmundseth

Trondheim 10.06.2016

Shunan Zhao

Content List

Abstract	I
Preface	II
Abbreviations	VII
Chapter 1 Introduction.....	1
1.1 FPSO-shuttle Tanker Tandem Offloading Operation	1
1.2 Motivation.....	2
1.3 Basic Theory	2
1.3.1 Basic Expression of Risk Analysis.....	2
1.3.2 Risk Modeling of Collision	4
1.4 Risk Analysis Approach to Collision Modeling.....	4
1.5 Introduction of the Software Risk Spectrum.....	5
1.6 Limitation	5
Chapter 2 FPSO-tanker Collision in Tandem Offloading Operation.....	6
2.1 Frame of FPSO and shuttle tanker DP system	6
2.1.1 FPSO arrangement	6
2.1.2 Shuttle Tanker DP System.....	8
2.1.3 Components of DP system	9
2.2 Hazards for FPSO-tanker Tandem Offloading Operation.....	16
2.3 The time window for action initiation.....	17
2.4 Recovery Process.....	18
Chapter 3 Risk Analysis for Scenario of the Collision and Near-miss events	20
3.1 IMCA Drive-off case analysis and classification.....	20
3.2 Bow-tie Diagram.....	25
3.3 Assumption and Limitation	26
3.4 Fault Tree Analysis of Drive-off	27
3.4.1 Method Description	27
3.4.2 Purpose of the FTA	27
3.4.3 Fault Tree Construction	28
3.4.4 Minimum Cut Set	34
3.5 Different Layouts of Offloading.....	34
3.6 Event Tree Analysis of Drive-off	36
3.6.1 Method Description	36
3.6.2 Purpose of the ETA	37
3.6.3 Event Tree Construction	37
3.6.4 Quantitative Analysis.....	39
3.6.5 Risk Picture.....	41
Chapter 4 Bayesian Risk Influence and Decision Support Diagram	44
4.1 Theory of Risk Influence and Decision Support Diagram and Introduction of GeNIe Software	44
4.2 Construction of Diagram for Collision Scenario	44
4.2 Condition Decision Table.....	50

4.3	Contingency Plan for Drive-off	50
Chapter 5	Online Risk Decision Support System	53
5.1	System Concept.....	53
5.2	System Structure	55
5.3	The Modeling of Data Analysis on DP System, Operator and Environment.....	57
5.4	Modeling of Available Time Window for Successful Recovery and Vessel Trace	61
5.5	FTA as the Node of Bayesian Risk Influence and Decision Support Diagram	63
5.6	The Modeling of Collision effect	67
5.7	Modeling of Probability of Avoid Contact	69
5.7.1	Theory of Probability of Impact Collision	69
5.7.2	Application in the drive-off scenario.....	70
5.8	HMI.....	72
5.9	ORDSS Working Process	74
5.10	System Interface and Component Selection	76
5.11	Risk picture to deploy ORDSS.....	76
Chapter 6	Discussion	78
6.1	Suitability of Risk Spectrum for FTA and ETA.....	78
6.2	Comparison the risk pictures of different layouts and deploying Online Risk Decision Support System	79
6.3	The Validity of the ORDSS	80
6.4	Procedure to Select Position Reference Systems Online.....	83
Chapter 7	Conclusion and future work	85
7.1	Conclusion.....	85
7.2	Future work.....	86
	Reference	88
	Appendix I	92
	Appendix II	99
	Appendix III	140
	Appendix IV	144
	Appendix V	148
	Appendix VI	149
	Appendix VII	154
	Appendix VIII	158
	Appendix IX	159

List of Figure

Figure 1 Offshore Tandem offloading (Vinnem, 2014).....	1
Figure 2 Spread Mooring (Blue Water, 2013).....	6
Figure 3 Single Point Mooring FPSO (Chen, 2004).....	7
Figure 4 DP Schematic (SMSC, 2016).....	8
Figure 5 the relationship among the sensors and PRS (Edvardsen, 2016).....	9
Figure 6 Prediction Test.....	13
Figure 7 Structure modeling of Shuttle Tanker DP 2.....	15
Figure 8 Structure modeling of Cjoy mode.....	16
Figure 9 Information-Decision-Execution Model for DPO reaction in drive-off scenarios (Chen, 2004).....	18
Figure 10 Drive-off Mode Distribution.....	20
Figure 11 Distribution of Drive-off.....	21
Figure 12 Bow-tie Diagram of Drive-off Scenario.....	25
Figure 13 CPP System.....	29
Figure 14 Layout 1.....	35
Figure 15 Layout 2.....	35
Figure 16 Layout 3 (Chen, 2013).....	36
Figure 17 Recovery action.....	38
Figure 18 Decision Diagram for Drive-off.....	45
Figure 19 Risk Influence Factor to Drive-off and Evidence.....	45
Figure 20 Countermeasures selection to deal with Drive-off.....	46
Figure 21 Influence factor to operation mode.....	47
Figure 22 Risk influence factors to Direction of Heading when vessel is on the collision course.....	48
Figure 23 Risk influence factors to Direction of Propulsion.....	49
Figure 24 Drive-off but not on the collision course with FPSO.....	49
Figure 25 DP system, ORDSS and DPO as Safety Barrier.....	54
Figure 26 Structure of ORDSS.....	55
Figure 27 Generic RIF model for execution and control activities (Vinnem, 2011).....	58
Figure 28 Construction of Integrated Intelligent Model.....	59
Figure 29 Fuzzy TS NARX dynamic Mode.....	60
Figure 30 Speed-time plot of simulation of shuttle tanker drive-off (Chen, 2004).....	61
Figure 31 Picture to Demonstrate Collision Condition.....	68
Figure 32 Risk Mode of Vessel Colliding with Rock.....	70
Figure 33 Width of Maneuvering Course and Safety Zone.....	71
Figure 34 HMI.....	73
Figure 35 The inaccuracy predication area.....	81

List of table

Table 1 Classification and its Number.....	21
Table 2 Risk Picture for Layout 1.....	41

Table 3 Risk Picture for Layout 2	42
Table 4 Risk Picture for Layout 3	42
Table 5 Countermeasures to Deal with Drive-off.....	46
Table 8 Operation Steps and Responsibility Distribution	51
Table 6 ST with ORDSS working at layout 1	76
Table 7 Comparison among different layouts and arrangement.....	79

Abbreviations

CCU	Joystick control unit
Cjoy	Joystick control panel
CPP	Controllable Pitch Propeller
DPO	Dynamic Position Operator
DP	Dynamic Position
DARPS	Differential Absolute and Relative positioning Sensor
DGPS	Differential Global Positioning System
ETA	Event Tree Analysis
FTA	Fault Tree Analysis
FPSO	Floating Production Storage Unit
GNSS	Global Navigation Satellite System
ICAS	Integrated Control and Alarm System
HiPAP	High Precision Acoustic Positioning
MCS	Minimum Cut Set
MRU	Motion Reference Unit
NCS	Norway Continental Shelf
OS	Operator Station
SMSC	Ship Modeling & Simulation Center
PFM	Power Forward Movement

Chapter 1 Introduction

1.1 FPSO-shuttle Tanker Tandem Offloading Operation

On the Norway Continental Shelf (NCS), the majority of FPSO use tandem offloading operation as Figure 1 presents. It is the main point discussed in this study.

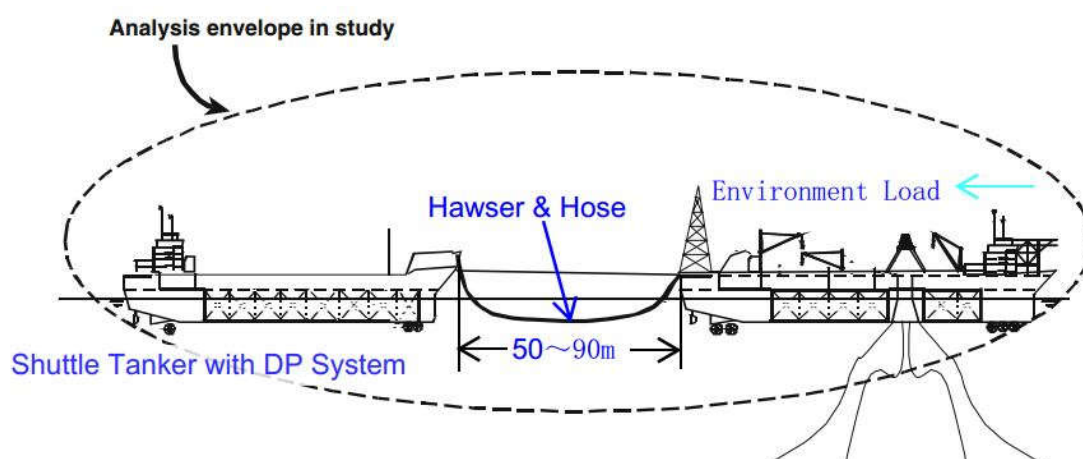

Figure 1 Offshore Tandem offloading (Vinnem, 2014)

The tandem loading is the shuttle tanker keeping position at some distance away behind FPSO, e.g. 80m. The two vessels are physically connected with a hawser and an offloading hose to transfer cargo oil from FPSO to shuttle tanker. The shuttle tanker can keep a relative stable distance and heading with its own Dynamic Positioning System (DP), and the hawser is not in tension (in DP mode), or by providing certain astern force and maintaining a small tension on hawser (Taut hawser mode). The shuttle tanker with DP 2 system has a good endurance performance in harsh environment. Therefore, it is widely used on the NCS.

There are five operation phases for FPSO and DP shuttle tanker tandem offloading operation in principle in the view of the shuttle tanker (SMSC, 2000).

Phase 1: Approach: tanker approaches FPSO stern and stops at a pre-defined distance

Phase 2: Connection: messenger line, hawser and loading hose are connected

Phase 3: Loading: oil is transferred from FPSO to tanker

Phase 4: Manifold is flushed, and loading hose and hawser are disconnected

Phase 5: Tanker reverses away from FPSO stern while sending back hawser messenger line, and finally sails away from field.

The tandem offloading operation is a long time consuming and complicated marine operation. It may vary from 3 to 5 days due to the offloading rate, the capacity of FPSO storage, and the gross loading capacity of the shuttle tanker. The period of the operation time is 24 hrs continuously at a required environment condition (Chen, 2004).

1.2 Motivation

According to Lundborg investigation in 2014, the possibility of shuttle tanker failing to recovery and to collision with FPSO is $5.0E-01$ (Lundborg, 2014), when the shuttle tanker drives-off in the tandem offloading phase. In addition, as to the Jiang's finding according to IMCA incident records from 2000 to 2010, there are 30 drift-off/drive-off incidents for the shuttle tanker installing DP system. The number of drive-off incident is 22, accounting for 73% of total losing position incidents. Therefore, it is necessary to analyze the risk of drive-off, and to establish a new barrier to reduce the possibility of collision consequence and collision effect.

1.3 Basic Theory

1.3.1 Basic Expression of Risk Analysis

Risk Analysis can be a proactive approach to deal with a potential accident and provide the answers to the three questions as below (Rausand, 2011),

Q1: What can go wrong (*i*)?

This thesis is to identify the reasons of drive-off to causes the collision between tanker and FPSO in tandem offloading.

Q2: What is the likelihood of that happening (P)?

In this thesis, the answer is to give a qualitative statement from A to D Level to describe the possibility of a potential collision.

Level A (Happen): The Drive-off has happened

Level B (High): High Potential to drive-off

Level C (Low): Low Potential to drive-off

Level D (Safe): Healthy System

Q3: What are the consequences (C)?

The consequences of drive-off are divided into 4 degree from A to D Level.

Level A (Serious): Collision energy is higher than 15 MJ, and collision is within a certain amount of time and severe consequence.

Level B (High): Collision energy is higher than 15 MJ, and Collision within a certain amount of time and light consequence or Oil Leakage

Level C (Low): No collision, but Loss Offloading Time

Level D (Safe): An excursion

For the risk expression in offshore industry, it equals to multiply the probability (P) of accident and numerical value (C) of accident consequence for each accident scenario (i), and summed over all potential accident consequences and express as Formula 1.1:

$$R = \sum_i (P_i \cdot C_i) \quad (1.1)$$

The risk value (R) is an expected value expressed by the formula. It could also be replaced by an integral, if the consequences could be expressed as a continuous variable (Vinnem, 2013). Levels from A to D to express probability value and consequence value are used to calculate the risk value.

1.3.2 Risk Modeling of Collision

A collision model includes all operation phases in tandem offloading between FPSO and shuttle tanker. The collision possibility, $P(\text{Collision})$, can be expressed as the Formula 1.2,

$$P(\text{Collision}) = P(\text{UFM}_i) \times P(\text{Failure of Recovery} \mid \text{UFM}_i) \quad (1.2)$$

$P(\text{UFM}_i)$ is the probability of shuttle tanker uncontrolled forward movement, and $P(\text{Failure of Recovery} \mid \text{UFM}_i)$ is the probability of recovery failure initiated from tanker, conditioned on tanker UFM (Chen, 2004).

However, there are several tandem loading layouts, as shown in chapter 3.4, where some shuttle tanker is not directly heading to the stern of the FPSO in some field. If shuttle tanker is drive-off straightly forward only, it cannot collide with FPSO. Therefore, the condition probability $P(\text{UFM}_i \mid \text{On the collision course with FPSO})$ and $P(\text{On the collision course with FPSO})$ should be introduced. And the new Formula 1.3 is shown as below,

$$\begin{aligned} P(\text{Collision}) = & P(\text{On the collision course with FPSO}) \\ & \times P(\text{UFM}_i \mid \text{On the collision course with FPSO}) \\ & \times P(\text{Failure of Recovery} \mid \text{UFM}_i) \end{aligned} \quad (1.3)$$

1.4 Risk Analysis Approach to Collision Modeling

Fault Tree Analysis is to perform the cause analysis contributing to the drive-off, and an assumption possibility of basic events is to complete the Minimum Cut Set (MCS) analysis and to compare the effect to the possibility of drive-off by different operation practice. Event Tree Analysis is to perform the analysis for different drive-off scenarios with different countermeasures executed and to present different risk pictures. Bayesian Influence Diagram is deployed to select the proper countermeasure to assist to make decision to reduce the possibility of collision, the serious level of

collision, life saving, environment pollution prevention, and time losing during tandem offloading.

1.5 Introduction of the Software Risk Spectrum

The Risk Spectrum software is the risk management software which is licensed for use at 50% of world's nuclear power plants. It is used to assess& manage risk, and reliability& availability. It is a tool for risk informed decision making and risk importance of equipment. And it will be used to conduct FTA and ETA for the collision and near-miss event scenario.

1.6 Limitation

The specifications of FPSO and shuttle tanker are different according to the shipowners` preference and the oil field characters. Also there is not a specific operation and emergency preparedness procedures in oil field operation company and shuttle tanker operation company. All of those may present different collision risk pictures. In this study, the technical systems of FPSO and shuttle tanker are considered to be purpose- built. Due to the shortage of data source, the environmental condition and procedures are assumed as Chen`s Dissertation(Chen, 2004), and it applies to the Haltenbanken area in the Norwegian Sea.

In addition, the reliability of technical components, human error probability, and the probability of some event are impossible to get due to the shortage of data source. Therefore the quantity analysis is based on assumptions according to the report of "Operation Safety of FPSO and Shuttle Tanker Collision Risk" from SINTEFF/NTNU, "Reliability Data for Safety Instrumented System" from SINTEFF and "Handbook of Human Reliability Analysis with Emphasis on Nuclear Power Plant Applications" from A.D. Swain and H. E. Guttman.

Chapter 2 FPSO-tanker Collision in Tandem Offloading Operation

2.1 Frame of FPSO and shuttle tanker DP system

2.1.1 FPSO arrangement

Floating Production Storage Offloading Unit is a floating unit used by the offshore oil and gas industry for the production and processing of hydrocarbons, and storage of oil. It utilizes a special design philosophy to combine traditional vessel building technology and mobile offshore platform. In terms of mooring method, there are two types of FPSO, single point mooring and spread point mooring. There are two types of spread mooring FPSO. One is vessel shape working at Lula field, Brazil, and the other is column shape working at Goliat, Norway. Different mooring installation will influence on the offloading form which introduces at chapter 3.

Spread mooring systems are multi-point mooring system in which the vessel is moored to the seabed using several mooring lines. The spread mooring vessel is in a fixed heading direction. The bow does not rotate along the wave, wind, and current changing. It also does not use any thruster to keep the position. The detail is as the Figure 2 from Blue Water.

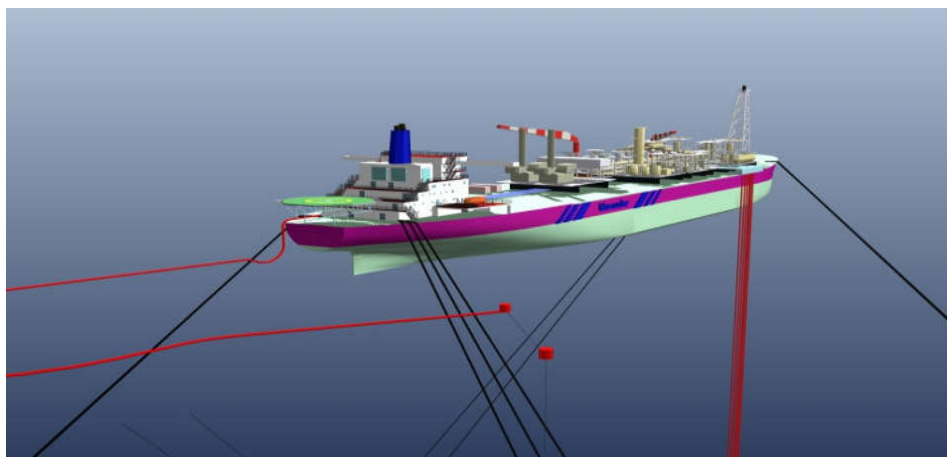

Figure 2 Spread Mooring (Blue Water, 2013)

The other type FPSO, single point mooring, is the most common one on the Norwegian Continental Shelf. The following definition to this type of FPSO is as in the NORSOK Standard (NTS, 1998):

FPSO- Ship Shaped Floating Production, Storage and Offloading Unit

A floating unit can be relocated, but is generally located on the same location for a prolonged period of time. Inspections and maintenance are carried out on location. The FPSO normally consists of a ship shaped hull with an internal or external turret and production equipment on the deck. The unit is also equipped for crude oil storage. The crude may be transported to shore y shuttle tankers via an offloading arrangement of a North Sea FPSO is shown in Figure 3. The living quarter and control room are located in the bow, upwind of any hydrocarbon fire. The turret is installed in forward part of the ship. The process area is aft of the turret, elevated from the main deck with natural ventilation. The oil storage tanks mainly locate behind the turret and inside the hull. The offloading system is installed at the stern. The flare tower and engine room are located at the aft of the vessel.

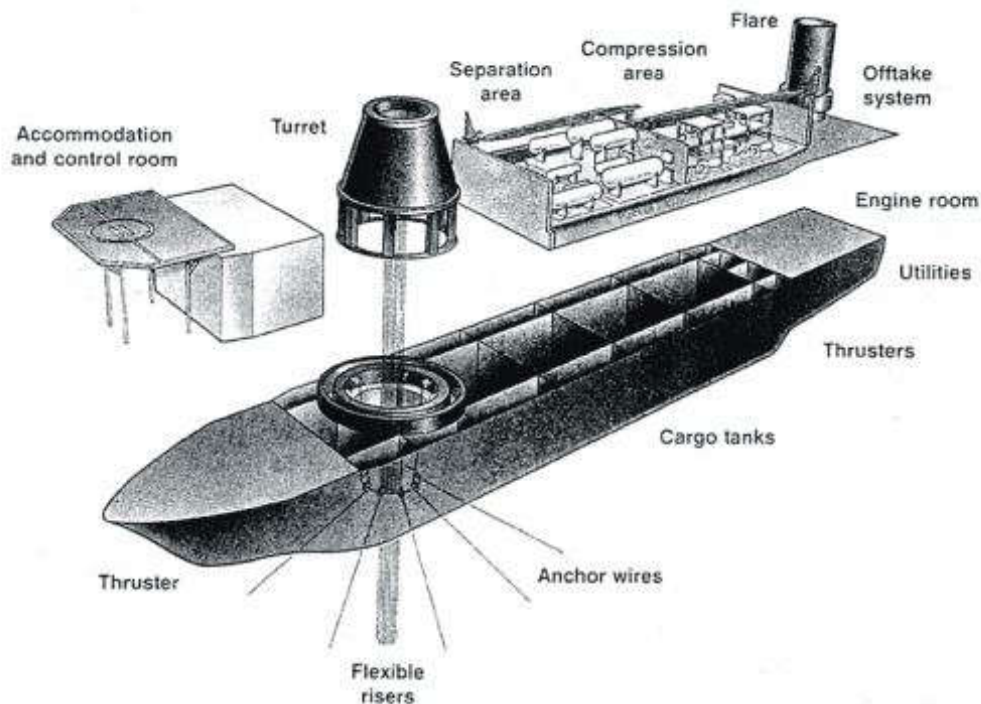

Figure 3 Single Point Mooring FPSO (Chen, 2004)

The FPSO works in a weather-vaning operation mode, and keeps the vessel always

heading towards the environmental forces around a fixed point, the turret. And thrusters installed at bow and aft of the vessel are utilized to assist the heading to reduce the little environment load to rotate the vessel frequently and to provide a drag force to the mooring chains, but the thrusters does not turn the FPSO during the collision scenario (Arntzen, 2016).

2.1.2 Shuttle Tanker DP System

Dynamic Position (DP) system shown in Figure 4 is a close-loop computerized system for automatic position and heading keeping system. In order to control the position and heading, the system utilizes data from various sensors and position reference system (PRS) as input data to DP control system. Set-point or defined vessel course are specified by operators. In combination with the operator's order, all the information and signals are processed into DP Control Unit (DPC). After processing, the DPC sends control signals to the thrusters and propulsion systems. Furthermore, it is not only a simple automation system but a working loop including DPO operation as well (Tone, 2013). The design philosophy of DP system is that a simple known failure or fault cannot cause position loss. When position or heading deviates from setting due to environment load, the DP system allocates thrust to recover the original setting point. And it will recover the heading first instead of position (SMSC, 2016).

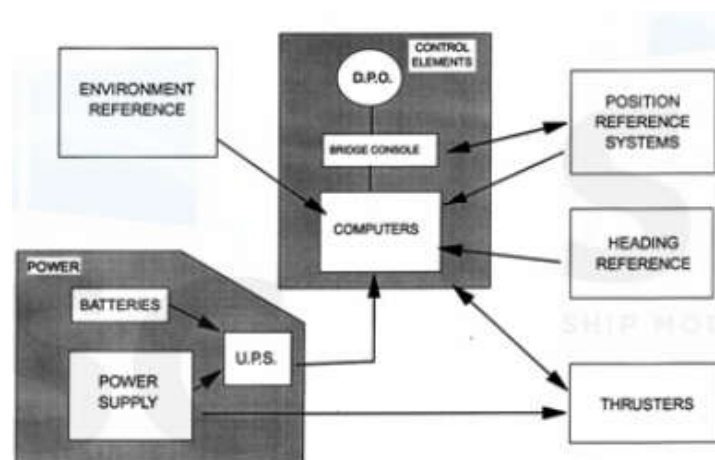

Figure 4 DP Schematic (SMSC, 2016)

The shuttle tanker DP system is to keep the relative position with the FPSO during

Tandem Loading Operations. It consist mainly five parts, and they are Operator Station, Sensor System, PRS, DPC and Propulsion System. For the various function for DP vessels, the components of DP system are variable. For a shuttle tanker, DP 2 system is normally installed on the vessel operating on Norwegian Continental Shelf. In this paper, the DP 2 Shuttle Tanker is used as an example to analysis.

2.1.3 Components of DP system

All the components installed on the DP2 shuttle tanker will be introduced below,

- Sensor System

The sensor system includes No.1, 2 &3 Gyrocompass, No.1 &2 Motion Reference Unit (MRU), No.1 &2 Wind Sensor, Draught Sensors system. The relationship among PRS and sensor system is shown as Figure 5

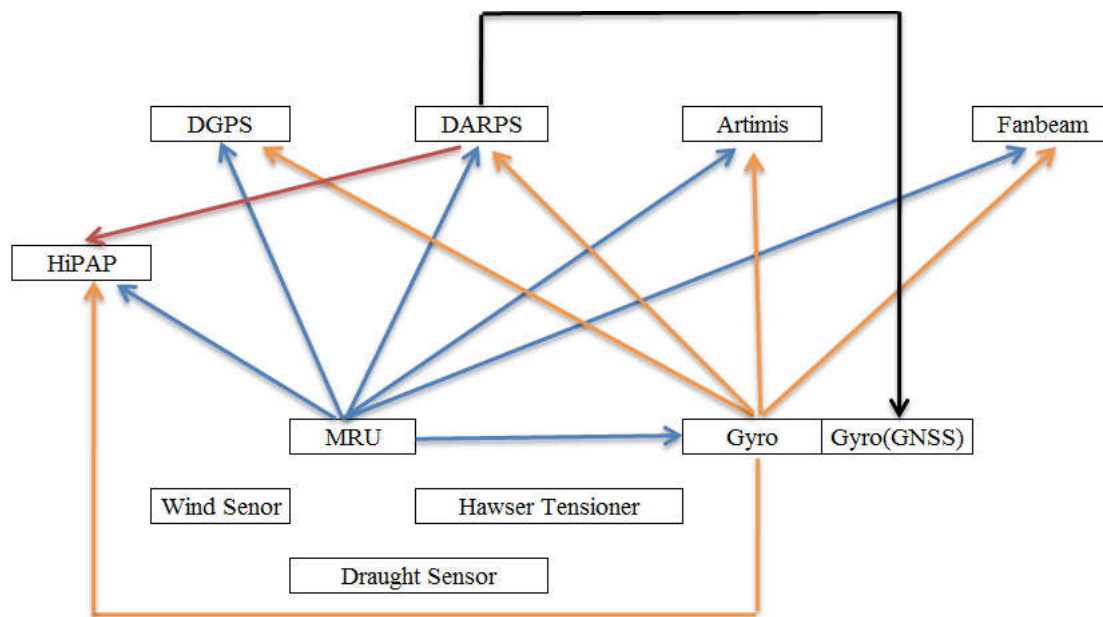

Figure 5 the relationship among the sensors and PRS (Edvardsen, 2016)

- MRU

MRU is a sensor to detect the roll, pitch, and heave motions. Its signal is used to input to motion compensation and ship motion monitoring. It can output surge and sway acceleration output. The acceleration range is $\pm 50 \text{ m/s}^2$ and acceleration accuracy is 0.05 m/s^2 (Kongsberg, 2014).

With the vessel rolling and pitching all the time, all of PRS system and Gyrocompass are rolling and pitching all the time and their measurements are changing in a certain extent. The MRU signal works as a compensation signal to the other measurement to reduce the effect by vessel rolling, pitching and heaving (GPS measurement is not affected by heaving)

- Gyrocompass

A gyrocompass is a type of non-magnetic compass which is based on a fast-spinning disc and rotation of the Earth (or another planetary body if used elsewhere in the universe) to automatically find geographical direction. There are three types of Gyro installed onboard now. They are GNSS (Global Navigation Satellite System) Gyro, Electrical Gyro and Mechanical Gyro. GNSS Gyro has own GPS (GNSS).

With the vessel yawing all the time, all of PRS system are yawing all the time and their measurements are changing in a certain extent. The Gyro signal works as a compensation signal to the other measurement to reduce the effect by vessel rolling, pitching and heaving (GPS measurement is not affected by heaving). And the DARPS will send signal to GNSS Gyro to maintaining the heading orientation. In this paper, the No.3 Gyro is GNSS Gyro and is influenced by No.2 DARPS.

- Wind Sensor

Wind sensor is to detect the wind speed and direction.

- Draught Sensor

Draught Sensor is to monitor the draught of vessel

- Hawser Tension

Hawser Tension is a simple sensor to monitor the tension force of the hawser between Shuttle Tanker and FPSO

The DPU performs a selection on the value from a sensor group. The sensor group

consists of two or three sensors, and DPC will de-select any of the sensors that are greater than predefined limit and issue a warning to the operator. Therefore each sensor is standby for each other or works online at same time.

- Position Reference System

The Position Reference System includes No.1 &NO.2 DARPS, Artemis MK 5 Mobile, Fanbeam, No.1 &No.2 DGPS, and HiPAP. The function of the component lists as below,

- DARPS

DARPS is a DP position reference system tailor made for offshore loading operations. It includes features such as direct selection by the DP to DARPS system and continuously updates of absolute and relative positions to the DP. DARPS signal will be influenced by MRU and Gyro.

- Artemis MK 5

Artemis MK5 is an accurate, automatic microwave position fixing system of the range bearing type relative to a fixed position using microwaves. Artemis signal is influenced by MRU and Gyro

- Fanbeam

The Fanbeam system is primarily used as a DP reference sensor measuring the relative position of a vessel to an offshore structure such as a FPSO. The system is regularly used as the primary position reference during critical short-range operations. Fanbeam signal is influenced by MRU and Gyro

- DGPS

Differential Global Positioning System (DGPS) is an enhancement to Global Positioning System that provides improved location accuracy with the assistance of onshore reference station. DGPS signal is influenced by MRU and Gyro.

- HiPAP

High Precision Acoustic Positioning (HiPAP) is utilized to position the vessel in both shallow and deep water. It deploys the transducers on the bottom of the vessel to communicate with the transponders installed on the seabed. The signal is affected by DARPS and Gyro.

Shuttle Tanker DP 2 PRSs consist of six individual systems. Due to the function of voting system and variance test, each system is a standby function to each other.

- Propeller& Thruster system

The thruster system includes CPP propulsion system and rudder system, bow thrusters, and azimuth thrusters.

- A. Bow &Aft Tunnel Thruster

Bow Thruster is a transversal propulsion installation on a ship.

- B. Azimuth Thruster

Azimuth Thruster is a configuration of propeller placed in a pod that can rotate to any horizontal degree to provide propulsion power.

- C. CPP Propulsion &rudder system

CPP propulsion system consists of propulsion marine diesel engine, shaft system, reduction gear (optional), and Controllable Pitch Propeller. Due to the installation of medium speed engine, the reduction gear is necessary for propeller efficiency. While with a low speed engine, the reduction gear is omitted. But in this paper, reduction gear is not selected to install onboard, so it is not analyzed.

- DP online test system

According to Kongsberg DP system, the DP online test system is to check whether the position measurements are accurate enough to take or not. There are four types of tests of which are Freeze Test, Variance Test, Prediction Test and Slow Drift Test. In addition, the Freeze Test and Prediction Test are also used to monitor all alarm point related to DP system, such as the pitch of CPP. The working principles of the four tests are introduced as below.

1. Freeze test

The freezing test detects and reports the repeating measurements. The system considers the same output from the component with caution. The output from component is monitored and rejected if the variation of the measurement is less than a predefined limit over a predefined time period. In addition, a warning and indication of the component in fault send to the system.

2. Variance, Weight and the Variance Test

DP system assigns different weighting to each PRS according to calculated variance. With a relative high variance, the weight of this PRS will decrease, and it has lower effect on the measurement of the vessel position.

3. Prediction test

The prediction test, as shown in Figure 6, continuously compares the model prediction value with the measurement. So the sudden measurement jump which is out of the rejection limit can be detected, and it is immediately reported to the DPO with a “Prediction Error” warning, and indicates this component is in fault condition. The Prediction test, which cannot reduce the load, stop, or deselect the component or the system, is only used to give a warning.

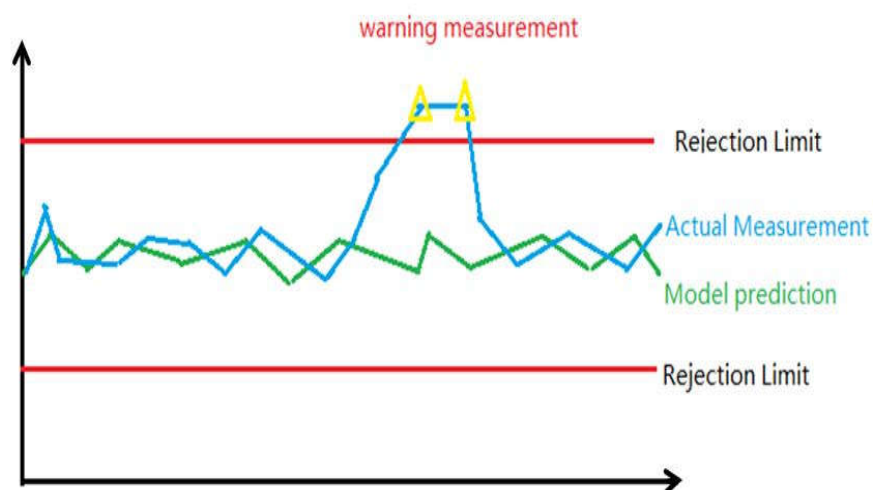

Figure 6 Prediction Test

- DP Voting System

The Voting System is to lower effects of unreliable measurement to DPC system. The voting system works only when there are more than three (including three) sensors or PRS. When one of the measurements is different from the other two or PRS Variance Test, the voting system will de-select the sensor with fault measurement or reduce the weight of PRS system. And the more accurate measurement can be input to the DP controller. But the Voting System could also select the inaccurate PRS measurement and reject the other accurate PRS due to the high weight of the inaccuracy PRS. This action is not taken as a fault of DP control system in this paper, since this is has been a common deficiency of voting system.

- Controller Unit and Control mode

The DPC is used in DP system, and there are three units in DP2 system. It performs all closed loop control and interprets operator commands and information from various sensors to provide the correct control signals for the vessel's propulsion and thruster system. (Kongsberg, 2015)

The joystick control system consists of CCU (Joystick control Unit) and Cjoy (Controller Joystick) mounting into a console – the Cjoy operation terminal. The controller unit communicates with the operator terminal via a single network connection. The system provides interfaces to the thrusters and necessary sensors. It is used in Joystick mode and auto heading mode. (Kongsberg, 2015)

There are several operation modes for DP system. And they are Standby mode, Joystick mode, Auto Heading mode, Auto Position mode, Auto Pilot mode, Auto Track mode and Follow Target mode (Weathervane mode). For a shuttle tanker, there are three operation modes are utilized for approaching the FPSO and position-keeping during loading. And they are Approach mode, used in the process of approaching to the loading point, Weathervane mode, the process of bow-offloading, and Connect mode, used in the process of connecting and disconnecting to the FPSO. There are generally two operation modes, Joystick mode and tandem loading mode, widely used during bow-offloading process.

A. Weathervane mode

The vessel is to rotate itself with the direction of the wind, current and waves around the FPSO. The propulsion force required to maintain the relative position decreases. The characteristics is as below

- 1) The vessel position in surge axis maintains at a setting distance from the bow to the FPSO without oscillations. The distance to the FPSO is presented as a trace that is a set-point circle, and the circle center is the FPSO.
- 2) Heading direction of shuttle tanker in yaw axis is under control to keep the heading degree steady and toward to the FPSO.
- 3) The vessel's position in sway axis can vary on the set-point and the environment load can drive the vessel to a optimal heading
- 4) Fishtailing is prevented due to the reduced vessel motion in sway and yaw axes

Tandem heading control is taken to follow FPSO heading rotation. The construction of tandem loading DP mode is shown as Figure 7

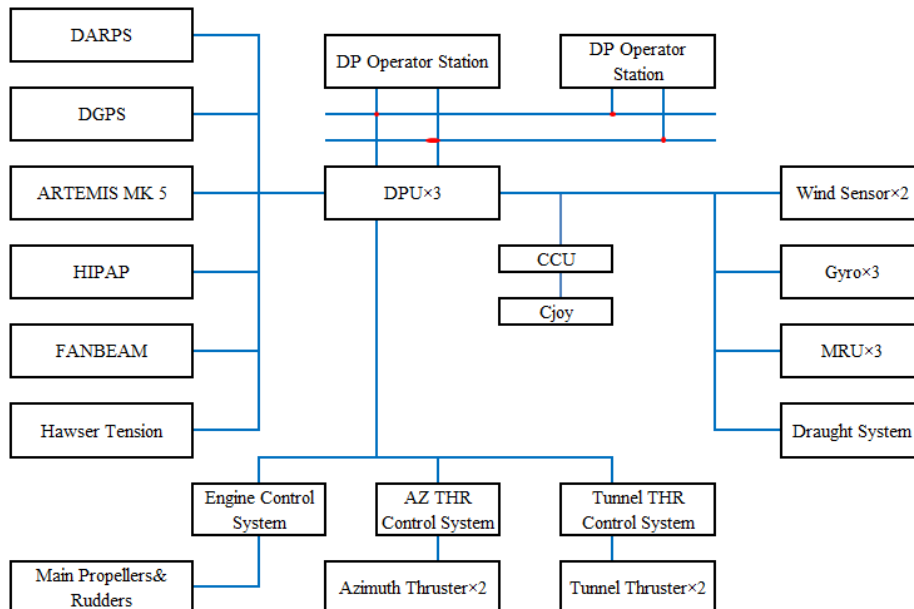

Figure 7 Structure modeling of Shuttle Tanker DP 2

B. Joystick mode

The joystick mode uses an integrated joystick with rotation knob to control the vessel or the platform to move along and athwart direction, and to rotate the heading. It can automatically allocate the power to each thruster and compensate for the wind forces acting on the vessel by providing certain appropriate direction force. In addition, with the position-reference system functioning, the mode can conduct balance activities automatically for the sea current and wave forces on the vessel or platform. Joystick mode is normally used in position loss operation. The final result is highly depended on operator`s skill and experience. The construction of Joystick mode of DP system is shown as the Figure 8

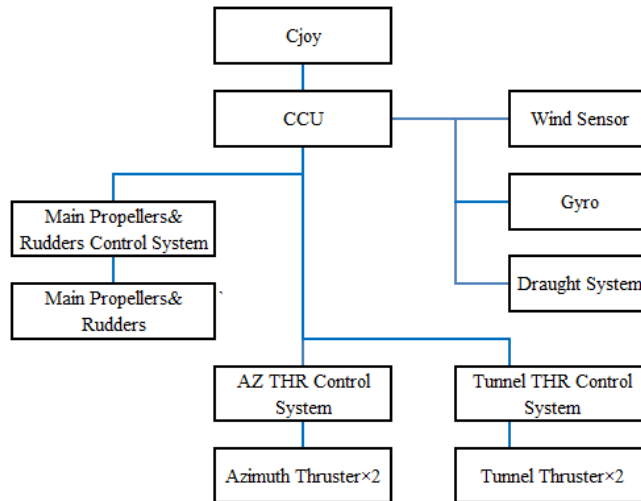

Figure 8 Structure modeling of Cjoy mode

2.2 Hazards for FPSO-tanker Tandem Offloading Operation

The tanker`s uncontrolled movement is the reason resulting in the collision between FPSO and shuttle tanker. The uncontrolled movement is normally classified into two groups, which are drift-off and drive-off.

2.2.1 Drift-off

Drift-off is a scenario that vessel or installation fail to provide sufficient thruster force to balance the environmental load so that it drifts away from the target position and

has excursion beyond the preset limit (Chen and Moan, 2005).

There are mainly two conditions that may cause the drift-off. The first situation is caused by the failures of the vessel system, such as unavailable electrical power on the main bus, total loss of DP computer or the malfunctioned thruster system. And the other one is the sudden or gradually increase of environmental forces, such as wind direction changes or environmental load is out of the scope of the ability that thruster force can balance (Chen, 2005). Certainly, the tanker could drift forward under dominant influence from wind and current. However, in such case, the tanker typically will not gain a dangerous speed to produce collision power higher than 15MJ within 80-100m to the FPSO stern (Chen, 2004). Therefore, it is considered as low probability and low consequence, and the drift-off case is not considered in this paper.

2.2.2 Drive-off

Drive-off is a scenario that there is fault direction and force from thruster to make vessel driven away from the target position with excursion beyond the preset limit (Chen and Moan, 2005). The vessel can increase speed dramatically since the drive-off can produce a certain amount of power. In this paper the drive-off will be analyzed only.

Malfunction of the shuttle tanker's technical system and fault operation are the reasons resulting in the FPSO-shuttle tanker collision. And these two causes are discussed below,

2.3 The time window for action initiation

To stop or rotate a shuttle tanker is never easy. Its thruster and turning system may take 20 to 40 sec to build up to their maximum astern/ rotation response (Chen, 2004). Therefore, time window to initiate action to achieve a successful recovery within a certain separation distance from FPSO without rotation is 53 sec for 80m, which is the normal separation between shuttle tanker and FPSO (Chen, 2004).

2.4 Recovery Process

A 3-phase Information-Decision-Execution model is established to model the information-processing phases that a DPO experiences from 0 to T1 as Figure 9 over the period of tanker driving-off. (Chen, 2004)

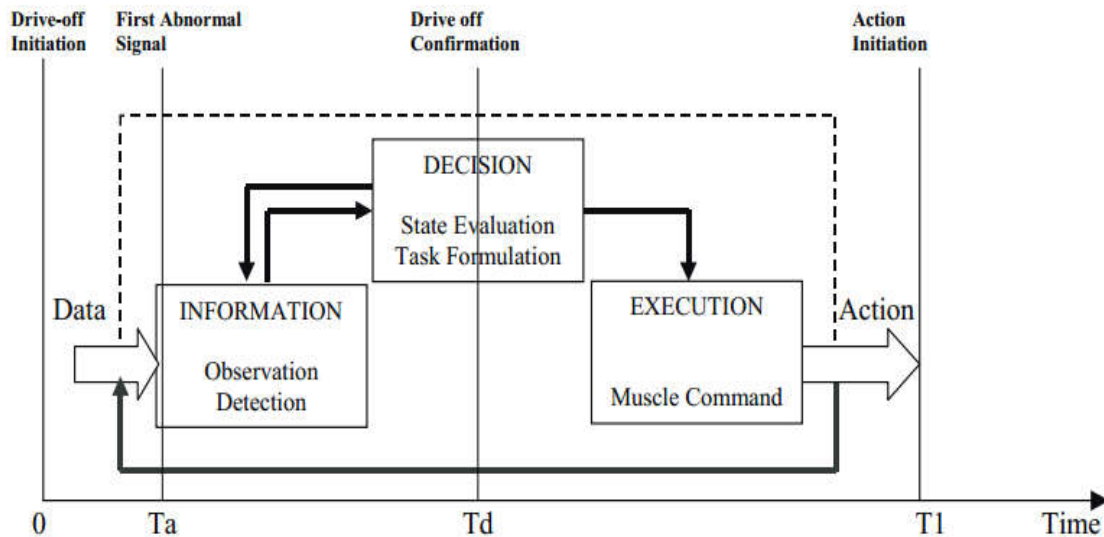

Figure 9 Information-Decision-Execution Model for DPO reaction in drive-off scenarios (Chen, 2004)

- Information phase

During the approaching, offloading and leaving operation, the DPO may detect the warning or the alarm, such as a distance alarm, a high power output high warning or increasing forward speed of vessel. After the abnormal condition has been detected, the DPO may begin to check the relative information to verify whether vessel is in a drive-off situation by going through different information sources, such as relative position to FPSO, speed, the amount and direction of output from each thrusters, alarm and warning history, etc.. In addition, when the propulsion force increase, it is normally accompanied with sound and vibration increasing and the color of exhaust of engines become black from colorless. The time period is from 0 to Ta

- Decision phase

This phase includes the interaction between condition evaluation and decision

making. During condition evaluation, the DPO takes all of the information into consideration. He/ she may detect it, but take it as only a fault signal, and then take a minor action to correct. Or a drive-off can be found by the operator. And he will go through the distance to FPSO, speed, and the thruster output all over again. The information can help him/her to estimate how serious the condition is. The time window leaves him/her to operate to avoid the collision. In addition, the operator should also consider the environmental force, and the availability of the power system, thruster system, propulsion system and turning, and response time during action planning. The time period is from T_a to T_b .

- Execution

The last phase is to execute the plan. The DPO monitors the execution condition of each step. When some actions in the plan are impossible to perform with malfunction in the machinery or electrical system, the operator should re-check the actual condition and make a new plan to carry out. In those cases, the execution phase is prolonged and the possibility of a successful recovery decreases. The time period is from T_b to T_1 .

Chapter 3 Risk Analysis for Scenario of the Collision and Near-miss events

3.1 IMCA Drive-off case analysis and classification

According to the DP system design philosophy, a single known failure should not cause a drift-off and drive-off (IMCA, 1999). Clarifying the root combination causes of drive-off can assist to further analysis and figure out the most effective countermeasures in short time within limited time window for DPO, and it could increase the time window for operation and increase the possibility for successful recovery. The classification below is based on IMCA position loss report from 1999 to 2006 and some other accident reports. All the position reference system faults causing by taut wire are not considered here since the vessels on Norwegian Sea abandon using it. Therefore, the total number of incident decreases from 104 to 87. The case list is as Appendix I, and a primary drive-off mode distribution is as Figure 10.

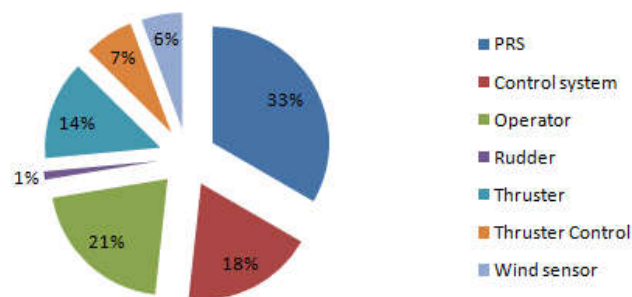

Figure 10 Drive-off Mode Distribution

This classification method is used in IMCA Position Loss Report .According to the DP system Design Philosophy, there is no drive-off due to single known fault of DP system. And normally drive-off could occur when two or more faults exist at the same time, ex, a drive-off caused by DGPS drift-off and the operator reselects the fault DGPS system. Therefore a new classification method that is based on DP Design Philosophy is deployed here to clarify the combination faults of drive-off. The

incident cases are based on the IMCA DP Position Keeping Incident Report from 1999 to 2006. The classification and number are displayed as Table 1.

Table 1 Classification and its Number

Classification	Number
Human Error	7
Human Error& Poor Practice	3
PRS &Human Error	3
PRS& Poor Procedure	30
Software Defect	14
Propulsion	14
Propulsion& Human Error	1
Propulsion& Control System	7
Two or More Gyros Fault and PRS at same time	1
Two or More Wind Sensors Fault at same time	5
Total	85

The percentage is shown as Figure 11.

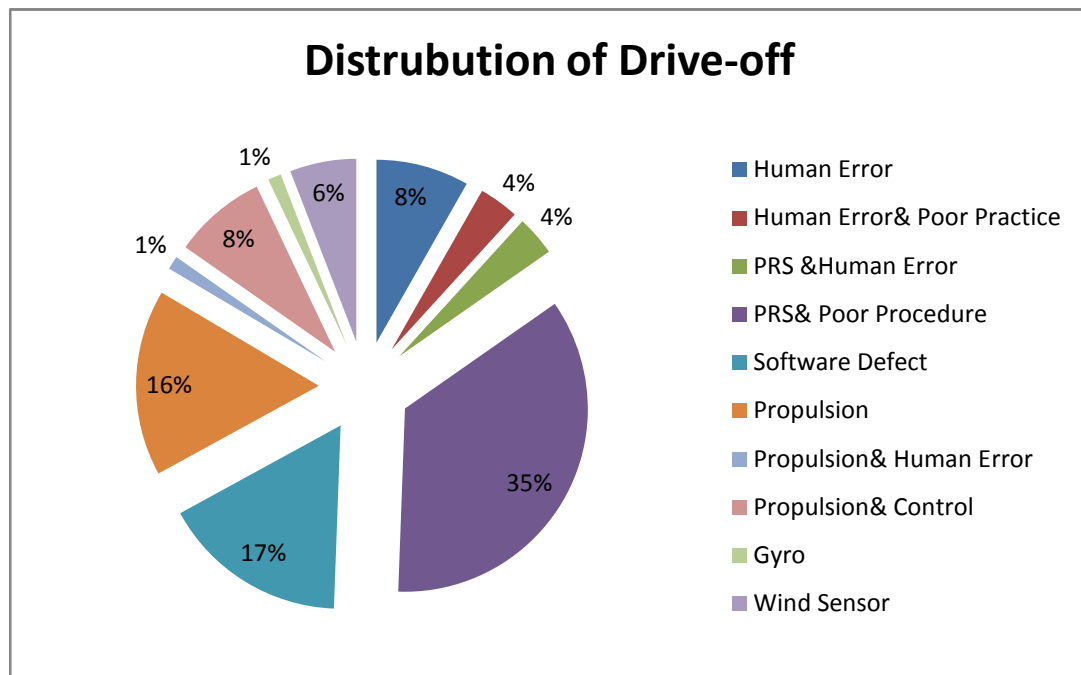

Figure 11 Distribution of Drive-off

A. Drive-off due to Human Error only

As the DPO is one element in DP system loop, a drive-off could happen due to DPO fault operation, such as select the fault DP mode, IMCA case 0210, inputting wrong information into the DP system, IMCA case 0143, due to lack of knowledge, training, focus ,etc. and in real life, the single human error causing drive-off also exists.

B. Drive-off due to poor practice and human error

There are three cases in this group. Firstly, it is a human error, but the practices of bridge and engine room resource management and safety zone management are poor, such as IMCA case 0518, and 0602. The drive-off happens.

C. Drive-off due to Position Reference System and Human Error

DPO may reselect the wrong signal or reject the right PRS signal as some accident investigation report indicates (SINTEF, 2002), and IMCA case 0305

In addition, the DP Controller system can also make the same mistake to reselect the fault PRS system theoretically, due to the DPC fault. But there has been no such case reported until now.

D. Drive-off due to Improper PRS selection mode

Improper PRS selection mode is the most common mode for PRS and there are total 30 cases, such as IMCA case 0421 and IMCA case 9910. And the fault selection modes could affect the DPC to choose the correct input signal due to the each sensor or each PRS weight distribution. In North Sea area, there is a procedure to select PRS for shuttle tanker tandem offloading operation, which there should be at least one absolute position system (DGPS) and two relative position systems online (SMSC. 2016). But there is no specific procedure to instruct how to select the combination and the weight distribution of all PRS.

And the case 0413 is removed from analysis since the relative information is not enough. It displays as below

- Only one type of PRS

In some case, 2 or 3 PRS sensors selected are the same types, ex, IMCA case 0205, IMCA case 0510. When common fault are caused by some reasons, the whole PRS system inputs fault signal to DPC unit, and drive-off happens.

- Only two types of PRS are selected as online.

Each type of PRS is perhaps one or two sensors, for example, 2 DGPS and 2 HPR, ex, IMCA case 0514. When any type of sensor is fault, it is difficult for DPC unit

to select which is the correct input signal, since each sensor is given by an equal weight. And to 2 DGPS and 1 HPR selection mode, when 2 DGPS fail due to common reason, the DPC unit will reject the correct HPR input but select the DGPS input, since the total DGPS weight is higher than HPR.

- Three type of PRS are selected online

There are three types of PRS online, ex, IMCA case 0116, for example, 2 DGPS, 1 Fanbeam, and 1 HPR. Each sensor has the same voting weight. Since the voting weight of DGPS are 50%, the analysis logic, voting system, in DPC unit selects the DGPS as the correct input signal, When the 2 DGPS are fault due to common reason, for example, lighting in IMCA case 0342.

Another case is that one of the PRS given too much high weight by operator or DPU as IMCA case 0039. With this high weight PRS fault, the DPC unit accepts the fault signal as the right one and rejects other correct ones.

The first two modes discussed above do not exist in offloading operation by shuttle tanker, since there should be at least 3 types of PRS online for shuttle tanker DP operation. The DPO on shuttle tanker should focus on the last one mode during PRS system selection and weight distribution

- DGPS/ DARPS fault affect Gyro

As IMCA case 0629, the DARPS is fault and incorrect signal sends to Gyro. As the DP will keep the heading priority, so the vessel adjusts the position to keep preset heading, and then drive-off happens.

E. Drive-off by Software Defect

There are 14 cases caused by software bug and fault, ex, IMCA case 0123 and IMCA case 0328. This problem belongs to unknown failure. Therefore it could be the simple cause.

F. Drive-off by Propulsion System

There are two type reasons to cause drive-off. One is caused by CPP Pitch Stuck and the other one is caused by abnormal output of propulsion control system.

- Drive-off by CPP Pitch Stuck

The CPP is installed on shuttle tanker, and the pitch of the propeller stuck at one position and cannot return to a lower, due to mechanical or electrical control problem, ex, IMCA case 0212 and IMCA case 0519. It will cause a higher power output than the vessel needed to balance the environment load, so drive-off happen.

- Drive-off by Propulsion Control System

As the Figure 7 indicates, the thruster output signal sends from DPC to each thruster through propulsion or thruster control system, which is a part of propulsion system. When the propulsion control system fails to transport the signal correctly, in the other words, to send a higher value of propulsion power to thruster, the drive-off happens, ex, IMCA 0340.

G. Drive-off by Propulsion and Human Error

There is one case in this group, IMCA case 0222. DPO ignore the propulsion prediction alarm.

H. Drive-off by Propulsion and Control system

The control system includes two parts, DPC unit system and propulsion control system. There are 7 cases of drive-off, since the propulsion control system output an inaccuracy and high dynamic output power control signal, when some of the propulsion systems fail and hawser of the offloading hose in high tension, ex IMCA case 0421 and IMCA case 0302.

I. Drive-off by Gyro

There is one case in this group. The Gyro system will affect other PRS accuracy due to heading yawing. And DP system will take heading keeping as first priority. In IMCA case 0324, heading measurement (Gyro signal) drifts off and vessel drive-off.

J. Drive-off by wind sensor

There are five cases about wind sensor, ex, IMCA case 0613. The wind sensors input spurious signal to DPC, due to some common cause, such as lighting, storm and so on.

3.2 Bow-tie Diagram

A bow-tie diagram, Figure 12, shows the correspondence between the causes and consequences of a hazardous event, and also the proactive and reactive barriers. Cause for accident and proactive barriers are shown to the left in the diagram, while the reactive barriers and consequences are shown to the right in the figure. In this paper, the Trigger Events are the causes to drive-off, the Hazardous Event is drive-off, and the consequence is the different serious degree of collision and near-miss. And the proactive barriers are DP system and DPO, and reactive barrier is only DPO.

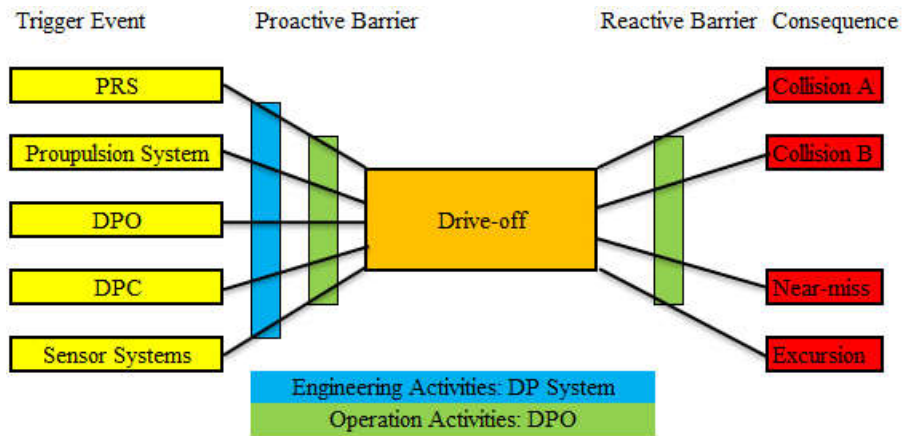

Figure 12 Bow-tie Diagram of Drive-off Scenario

Whether human error should include into the causes of drive-off or not is to clarify as below. The cause of drive-off, simple human error, is mentioned in previous chapter. When the Trigger Event(s) happened already cause drive-off and DPO fails to take action or take fault action to recovery, these operation activities are not included in the cause of drive-off. When there is a fault in DP system but the vessel is no in drive-off and DPO performs a fault intervention, the vessel drive-off. These operation activities are included in the causes of drive-off. When a DPO input a wrong order into DP system and the DP system execute the wrong order correctly and there is no any fault and failures in DP system, this drive-off is caused by human error simply.

3.3 Assumption and Limitation

The basic for the Risk Analysis is

- The vessel with DP can fully operate
- All of DP operator stations (OS) are functioning
- All control systems are function
- In previous Analysis, there is no error present

The control and DPU system consist of computer software and hardware (main processor, I/O Bus). Ideally, the control system could be assumed to be no errors after the system commissioning. In addition, software errors are difficult to predict within a reasonable scope. And the failure of the hardware will contribute to lose DP Capacity but not to drive-off. Therefore it is not necessary to analyze the control system into component and software level. But we can predict control system error probabilities based on experienced data from similar system and applications to use for Quantity Risk Analysis.

The position reference system is assessed on a system level represented by failure modes which in each case is considered to be relevant and sufficient for the item with respect to drive-off. And the propulsion system is assessed on a component level to find the details to conduct the drive-off.

Only the equipments that can have effect on vital functions are analyzed, therefore system supporting equipment like printers, data logging equipment etc. are not included.

Normally, the propulsion system will include one or two CPP propulsion system, one or two bow or aft thruster and one or two forward azimuth thruster and one aft azimuth thruster. The system construction is various as ship-owner preference. In this paper, it selects one CPP propulsion system with MAN 7S60MC diesel engine, two azimuth thrusters (aft & fwd.) and two thruster (bow & aft) as an analysis model. Even the equipment varies as different type, but the method to construct risk model is the

same.

As it is a tandem operation about shuttle tanker with FPSO, the shuttle tanker adjusts the position and heading to match with the FPSO. The normal type of FPSO operating on NCS uses weather-vane without thruster assisting to assist position keeping. In addition, the distances between the FPSO and shuttle tanker are not always the same, but it is normally 80 meters. And the distance can be assumed as 80 meters and the time from information, decision to execution phase is to be assumed within 53s (Chen.2004).

Any malfunctions that perhaps cause by irresistible force such as lighting, collisions with other vessel or platform, etc., are not considered in the analysis.

The collision scenarios are based on a same certain speed, loading and environment conditions.

3.4 Fault Tree Analysis of Drive-off

3.4.1 Method Description

A fault tree is a top-down logic diagram that displays the interrelationships between drive-off and the cause contributes to the drive-off happen. It is a binary analysis, and all events are assumed to be binary events that either occur or do not occur. No intermediate states are allowed in fault tree. (Rausan.2011)

3.4.2 Purpose of the FTA

FTA is used as a quantity analysis method, and it can calculate the probability of the drive-off and the probability of decreasing after using the online risk decision modeling. In addition, it can find the root cause of the drive-off to assist to establish the operation monitoring method and countermeasures to reduce the possibility of drive-off. In addition, it can help to set a warning system to assist operators to avoid the drive-off by monitoring the relative component dynamic condition.

3.4.3 Fault Tree Construction

The fault tree construction is based on the IMCA Drive-off case analysis and classification, and equipment manufacture manual.

A. Top structure

As the 3.2.3 mentioned, the drive-off can be summarize as two causes, and they are the DPO error, DP System fault, or a combination of DPO error and DP system fault. And the fault of position reference system, Propulsion System and DPC Unit can be classified in the DP Technical System. And the top structure is as Appendix II.

B. Human Error

According to drive-off classification, the human error can cause drive-off individually, which present in this human error fault tree branch. In addition, it can combine with other technical fault to cause drive-off together, which will presents in the technical system fault tree branch. There are two main types of error. One is that DPO selects the wrong operation mode. The other one is that DPO inputs wrong setting into the system. And both of these errors are caused by less of experience and careless.

C. DP Technical System

● Propulsion System

There are three causes theoretically to contribute this drive-off, and they are listed as below,

1. The propeller pitch of CPP stuck at a position and engine continues to run.

The CPP system includes hydraulic power system to control the pitch, oil seal system to prevent water ingress into the propeller and ship, pitch feed-back system and display as Figure 13.

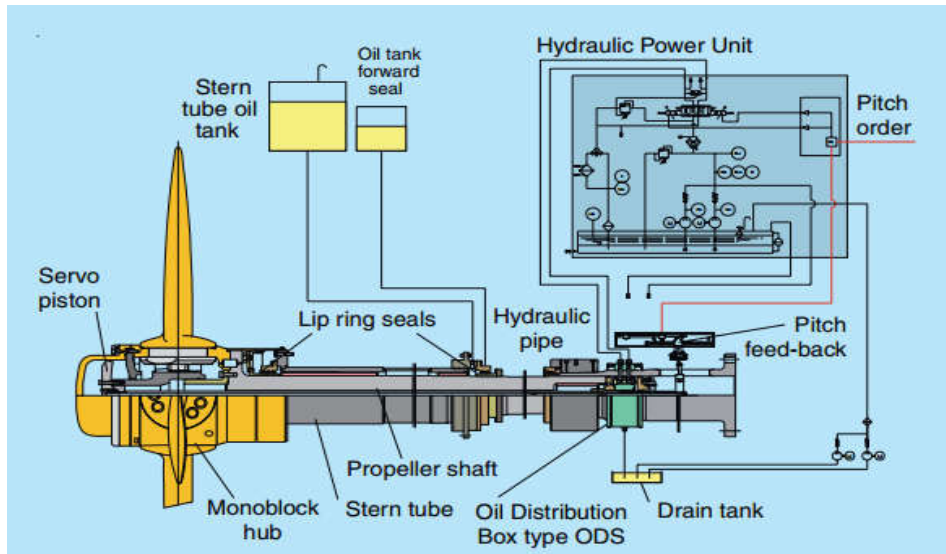

Figure 13 CPP System

There are 6 basic events to contribute under this OR-gate, since anyone happens will conduct to the DRIVE-OFF from CPP, they are listed and explained as below,

- a) CPP Pitch feed-back Sensor Incorrect Output: during pitch increasing, the required pitch has already reached, but it sends an incorrect signal to control system to continue to increase the pitch.
 - b) CPP Pitch feed-back Sensor Spurious Output: With the required pitch reach and is stable, it sends a spurious signal to control system to continue to increase the pitch.
 - c) CPP Pitch feed-back Sensor No Output: during pitch increasing to the required pitch, there is no signal sending to inform the control system to stop when it reaches the defined pitch.
 - d) CPP Pitch feed-back Sensor Interrupt of Cable: during pitch increasing to the required pitch, there is no signal to send to inform the control system to stop when it reaches the defined pitch.
 - e) The Servo Piston to control the pitch stuck: during pitch reducing, the servo piston fails to control the pitch to reduce and sticks at a position.
2. One or two thrusters fail and the output load transfer to the remaining thrusters.

As DP2 system, there should be at least two thrusters (the thruster here includes both engine-shaft-CPP and azimuth thruster) can provide forward propulsion power. With vessel in DP mode, when one of thruster fails, the propulsion load transfer to the remaining thruster or thrusters. Since the dynamic characteristics of the control system, the propulsion power could increase dramatically over the required power to balance the environment load. The failure mode of thrusters is not analyzed here in detail, since there are details about the reasons for the thruster load reduction or fall to zero in Class Rules such as DNV-TS-401 and sensors and alarms are included in the Integrated Alarm & Control System (IACS).

3. The azimuth thruster output power at any angle due to steering gear fault.

When the steering gear system fails to turn the thruster, the switch gear for the power supply to the thruster should be opened. With the switch gear not open, the thruster outputs a force at certain angle where it is stuck, and drive-off happen. And this orientation of the drive-off can be any angle. The failure modes of gear stuck and switchgear not open are not analyzed in details, since sensors and alarms are included in the IACS.

● Sensor System

There are three pieces of Gyrocompass, three pieces of Motion Reference Unit (MRU), three pieces of Wind Sensor, and one Draught Sensors system. For the MRU system monitors the vessel roll, and pitch.

The input to the DP system is utilized to calculate the thruster output to balance the environment load. Deploying the Voting System, the DPC would reject the fault system. But the DPC could also accept the fault data due to DPC fault. In addition, the DPO could also reselect the fault system. Then the vessel will move to balance the effect by fault data input. And the orientation of drive-off caused by sensor system is not only to move forward, but in any direction.

1. Wind sensor system

There are two individual sensors in each system. When one sensor is fault, operator

has to select the right one. Human error may exist in this phase. It should be included in the fault tree. The accuracy of wind sensor is affected by a wind shadow from adjacent upwind platform and helicopter landing and rising. Therefore, the failure modes are signal jump and signal freeze.

2. Hawser tension sensor

The failure mode of hawser tension sensor is signal jump and signal freeze. It is a stand-alone sensor system and it is not within the PRS voting system. It could cause drive-off, when the measurement is higher than the actual condition.

3. MRU

There are two types of MRU system fault. One is one of the three MRU fault and the fault one is reselected online by DPO fault intervention or DPC fault. The other one is 2oo3 fault at the same time, and the DPC select them as function one due to Voting System Logic. The failure modes of the MRU are signal output jump and signal output freeze.

4. Gyrocompass

There are two types of Gyro system fault. One is one of the three Gyro fault and the fault one is reselected online by DPO fault intervention or DPC fault. The other one is 2oo3 fault at the same time, and the DPC select them as function one due to Voting System Logic. The failure modes of the Gyro are signal output jump and signal output freeze. In addition, there is normally a GNSS Gyro installed onboard, and in this paper, No.3 Gyro is deemed as the GNSS type and is influenced by the accuracy of No.2 DARPS. Also, the accuracy of MRU also affects the Gyro as the introduction in chapter 2.1.2.

● Position Reference System

As the introduction in 2.1.2, there are five position reference systems installing on this shuttle tanker, and they are Fanbeam, Artemis, DGPS, HiPAP and DARPS.

1. DGPS

There are four modes of DGPS erroneous data, rapid or slow drift and position jump, sudden loss of data, and unstable position data (IMCA, 1997). And critical DGPS failure modes on the NCS are position jump and rapid or slow drift (Chen, 2006). Therefore, the two failure modes are chosen to analyze as the root reason. There are two DGPS. A drive-off will happen, when the two DGPS go to fault at same time or any of the two goes to fault, and reselected by DPO or DPC, or the weight of DGPS is higher than other PRS. With the accuracy of Gyro and MRU influencing on DGPS, the failures of the two systems are inputs in DGPS fault tree.

2. HiPAP

The accuracy of HiPAP is affected by acoustic refraction, particularly at long horizontal ranges from the transponder, caused by temperature or density of layers in the water (SMSC, 2016) and the erroneous modes are position jump and drift. As the accuracy of Gyro and MRU influencing on HiPAP, the failures of the two systems input in HiPAP fault tree.

3. DARPS

With the introduction previous, DARPS uses DGPS/ GLONASS based system to calculate the relative distance. Therefore the failure mode is same as DGPS, and they are position jump and rapid or slow drift. There are two DARPS onboard. With the accuracy of Gyro and MRU influencing on DARPS, the failures of the two systems are inputs in DARPS fault tree. A drive-off will happen, when the two DARPS go to fault at same time or any of the two go to fault, and reselected by DPO or DPC, or the weight of DARPS is higher than other PRS.

4. Fanbeam

The accuracy of Fanbeam is affected by the damp lences from rain and snow (SMSC, 2016). The erroneous modes of Fanbeam are position jump and rapid drift. With the accuracy of Gyro and MRU influencing on Fanbeam, the failures of the two systems are inputs in DARPS fault tree.

5. Artemis

The accuracy of Artemis is affected by radar transmissions from other vessel or shuttle tanker itself (SMSC, 2016). In addition, IMCA data base also records one case. An unauthorized platform staff wearing reflecting strip accessed to the fixed Artemis position, and the Artemis locked at the strip as the Artemis reflector, and ST was drive-off (IMCA, 2007). The erroneous modes of Artemis are position jump and rapid drift. With the accuracy of Gyro and MRU influencing on Artemis, the failures of the two systems input in Artemis fault tree

- Control System Fault

There are two parts including the DP control system and propulsion control system, three DPC units working in parallel and three individual thruster control units.

A. DP Control System

The DPC System consists of two parts, hardware and software. When the hardware fails, the broken-down component is impossible to transfer any communication between the DPC and propulsion control system. Therefore, it does not contribute to drive-off. With a fault in software, the amount and direction of propulsion power output order is not accuracy, and it causes drive-off. The two basis failure modes of software are DATA Virus and spurious output by software.

As three DPC control units working in parallel, the system uses voting algorithm to process the final output data. When there is one abnormal signal caused by software error or software spurious output, the system can detect and deselect the processing unit. So there are two types of DPC system fault. One is one of the three DPC fault and the fault one is reselected online DPC fault. The other one is 2oo3 fault at the same time, and the DPC select them as function one due to Voting System Logic.

B. Propulsion Control System

The thruster control system is “one to one” relationship to the thruster, and there is no redundancy among each. And the fault modes are the same as the DPC unit, and they are DATA Virus and spurious output by software. Therefore a single cause to drive-off is possible.

3.4.4 Minimum Cut Set

The quality analysis, minimum cut set, presents the element combination to induce the drive-off. The result outputs from software Risk Spectrum, and is as Appendix III.

There are ten basic events, and each one can cause ST drive-off by itself. It seems against the DP design principle that one known failure or fault will not cause position loss. However, these ten basic events are unknown case or cannot monitor, when they happen. Event 15& 16 are human error. Whatever the error operation is performed due to DPO slip, lapse, mistake, or even violation, the DPO behavior is unknown before DPO takes action. And same as the Event 17, 18 & 19, the propulsion system spurious output is unknown before it happens. In addition, these three single events are also used by DPO training center to simulate a drive-off (Chen, 2005). Event 23 & 24 are relative to hawser tensioning system. The signal output from hawser tensioning system is used in DP mathematic model, and it is not a part of voting system. Therefore, it is a single reason to cause drive-off. There is one drive-off case happened in 2010 and it is recorded in IMCA DP Station Keeping Incident Report (IMCA, 2012).

3.5 Different Layouts of Offloading

The position layout of FPSO and shuttle tanker presents the relative distance and heading-angle difference, and it has effect on the time window to successfully drive-off recovery, drive-off countermeasures and collision risk picture. There are mainly three layouts of offloading according to the requirement of different oil fields or company standards, and they present as below.

- a) Shuttle tanker keep heading to the stern of FPSO and 80m distance to FPSO

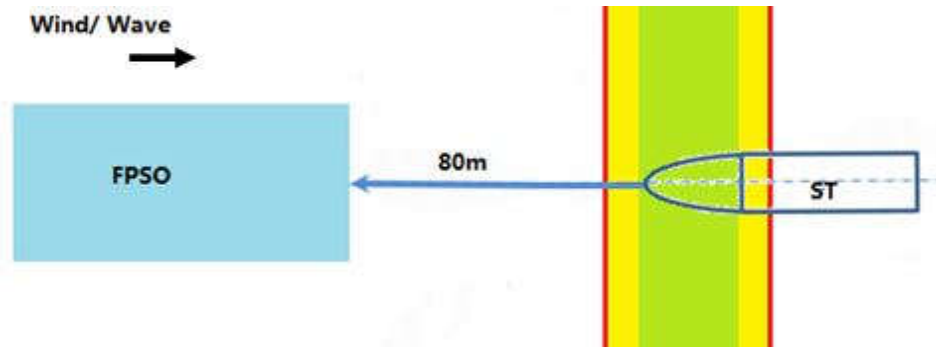

Figure 14 Layout 1

The layout 1 shown as Figure 14 shows is the most common method to offshore tandem loading at North Sea. All of the failure modes that cause the shuttle tanker forward drive-off (PFM) could put the shuttle tanker in high possibility of collision with the astern of FPSO. The countermeasures are normally to change the heading direction.

- b) Shuttle tanker keep heading to the stern of FPSO and 150m distance to FPSO

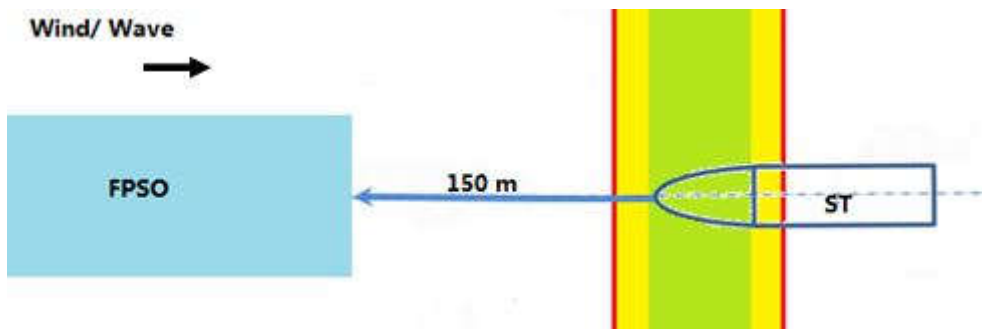

Figure 15 Layout 2

This layout 2 as Figure 15 shows is used in some fields (Vinnem, 2015). The difference from the layout 1 is 70m extended. All of the failure modes that cause the shuttle tanker drive-off could put the shuttle tanker in high possibility of collision with the astern of FPSO. The countermeasures are normally to astern propulsion the vessel or to change the heading direction. The layout 2 provide DPO with longer time window to recover the shuttle tanker from drive-off, but the FPSO should own a longer offloading hose and hawser.

- c) Shuttle tanker keep deviation angle heading to the stern of FPSO

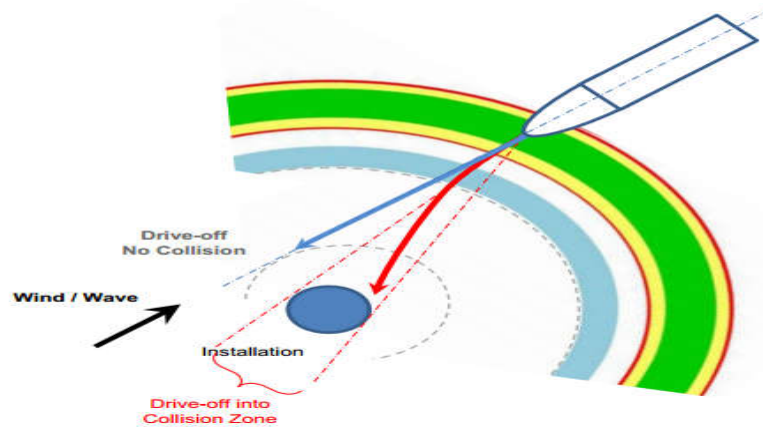

Figure 16 Layout 3 (Chen, 2013)

A new offloading layout as Figure 16 appears in the presentation of “Risks in DP Shuttle Tanker Offloading Operations” from Haibo Chen in 2013. And this loading method has been used by some oil company (Vinnem, 2016). The separated distance is 250m, min 150m no entry zone and no hawser is needed between offshore installations, such as FPSO and FSU (Chen, 2013). As the picture demonstrates, the shuttle tanker will pass by the FPSO and no collision happens, for example drive-off by propulsion system, when a forward drive-off happens. It simplifies the countermeasure, and it could be only to stop the shuttle tanker or to astern the vessel. And with a much longer separation distance, it could provide more time for successful recovery.

3.6 Event Tree Analysis of Drive-off

3.6.1 Method Description

The event tree analysis is a graphical and probabilistic method for modeling and analysis of the drive-off scenarios. The method is inductive and follows a forward logic. The resulting diagram displays the possible accident scenarios that may follow a near-miss and collision event. (Rausan.2011)

3.6.2 Purpose of the ETA

The FTA of DRIVE-OFF is to model the scenario from drive-off to collision or near miss-accident. It can use to evaluate the effect of different risk-reduction methods by different risk spectrum. In addition, the function event can be analyzed by fault tree. This analysis can find the critical point of the technical barriers, function events, and to monitor these points to improve the robustness of each barrier and decrease the final risk.

3.6.3 Event Tree Construction

There are mainly three parts in event tree, Initiating Event, Function Events and Consequence. The Initiating Event is drive-off as the Bow-tie Diagram display. And the function events are the recovery actions both happened during collision and near-miss scenarios.

The function events are “Heading on the Collision Course to FPSO”, “Abnormal Signal Detection within 30s”, “Making Decision within 53 s”, “Manual Takeover”, “Astern Thruster Initiating Successfully”, “Rotation Initiating Successfully”, and “Void Contacting with FPSO Stern” (Chen.2004).

And the consequences are near-miss and collision.

Function Event:

- Heading at the collision course to FPSO

As the explanation in chapter 3.3, some modes of drive-off do not direct to FPSO, since the heading direction varies, for example, drive-off caused by Position Reference System. In addition, as the layout 3 mentioned in chapter 3.4, the shuttle tanker cannot collide with FPSO, when the vessel only move straight forward.

- Abnormal Signal Detection within 30s

As the accident analysis, the first step is to detect abnormal signal. The time to find

the drive-off can determine the success of recovery ship, and 30s is a reasonable time limit for this action (Chen.2004).

- Making Decision within 53s

Normally, the tanker DPO will not simply disconnect oil offloading hose and initiate full astern maneuvering by reacting “automatically” to one or several signals. Therefore, after detecting the abnormal signal, the DPO should evaluate the condition and make decision what countermeasure should take or ignore the abnormal signal. And as the 80m operation distance, 53s is the limit for DPO to take actions.

- Manual Takeover

The DPO should de-select DP Weathervane mode to manual mode. The Joystick, thruster manual lever control mode are normally deployed to operate the vessel in emergency condition.

- Astern and Rotation

The normal recovery actions combine astern thrusting the vessel with the turning the heading angle (Chen.2004) as Figure 16 demonstrates. There is no difference between the sequence of these two actions. But the combination actions will enhance the possibility of successful recovery comparing with the only one single action.

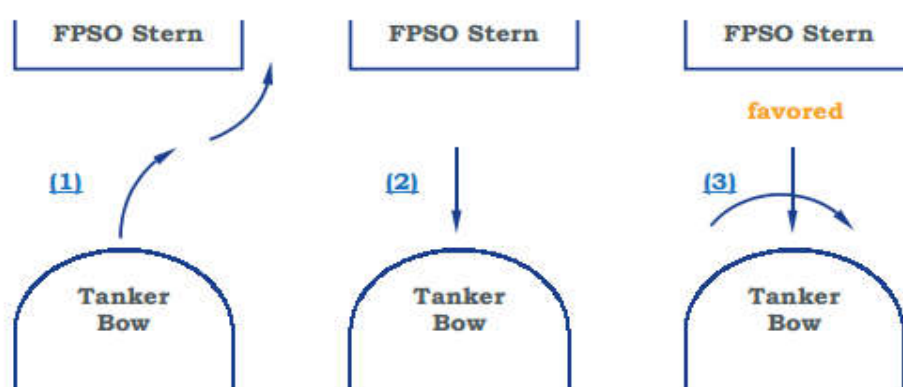

Figure 17 Recovery action

- Avoid Contacting with FPSO Astern

With the environment variable, it cannot be always successful to avoid collision after executing the one or two actions. The possibility of the function event will determine

the collision or near-missed condition.

The event tree is shown as Figure 14.

3.6.4 Quantitative Analysis

Since the available data source is limited, the possibility of function event in quantitative analysis is based on the Chen's Dissertation and a report from SINTEF. And the risk picture is presented by the software Risk Spectrum PSA.

- Initiating Event

The possibility of PFM is $9.0E-4$ from 2004 to 2013 (Lundborg.2014).

- Function event

- 1) Heading at the collision course to FPSO

As mentioned in the Motivation 1.2, the possibility of shuttle tanker is failure to recovery to collision with FPSO is $5.0E-01$ (Lundborg, 2014). Estimation for the drive-off at the collision course with FPSO is higher than 0.5. Therefore, I assume that the possibility of heading at the collision course to FPSO is 0.6.

- 2) The possibility of Abnormal Signal Detection out of 30s

In the report of Operation Safety of FPSO Shuttle tanker Collision Risk, SINTEF, 2002, it mentioned 5 near-missed incidents and collision accidents. There are only 2 cases to detect the drive-off in time, and details refer to the Appendix I. And therefore, I assume the possibility of Abnormal Signal Detection out of 30s is 0.6.

- 3) The possibility of Making Decision out of 53s

As Chen's dissertation introduced, the expert judgments based on simulator training indicate that the mean action initiation time for experienced tanker DPOs is about 85 s, and only 20 % to 30 % of them are able to initiate recovery action within a time window of 53 s (Chen.2004).But this possibility of the whole process includes the abnormal detection and decision making. Therefore, I assume that the possibility of Abnormal Signal Detection out of 53s is 0.5.

4) Fail to Manual Takeover

In the report from SINTEF, all the vessels had successfully changed to the Manual Mode. But there is one case that the operator is no experience to select the manual mode by fault. Therefore, I assume that the possibility of Fail to Manual Takeover is 0.1.

5) Fail to Operate Thruster

In the report from SINTEF, all the vessel had successfully activate the Astern Thruster. Therefore, I assume that the possibility of Fail to Astern Thruster is 0.2.

6) Fail to Change Heading

In the report from SINTEF, two of vessels had successfully rotated the vessel. Therefore, I assume that the possibility of Fail to Manual Rotation Initiating is 0.6.

7) Contacting with FPSO Astern

As Chen`s dissertation introduced, potentially the failure probability of recovery could be more than 50 %. Therefore, I assume that the possibility of contacting with FPSO Astern is 0.51

● Consequence Analysis

As the chapter 2.5 Collision Model presents, the collision result varies with the collision angle, shuttle tanker loading condition and the shuttle tanker speed different. Therefore, the consequences of the event tree should be evaluated by the property damage, environmental pollution, and loss of offloading time. The consequences are not limited only by collision and near-miss (NEAR-M). And they are as below,

1) Level A (Serious): Serious Collision, Oil Leakage, and Human Injury

This is most serious collision, since the shuttle tanker does not reduce the speed and turn the heading angle. Assumption is that it may result in flare tower collapse, fire and explosion on FPSO, riser and mooring chain damage, and engine room destroy in this condition. The collision energy is higher than 30MJ (Vinnem, 2014). Collision 1 can define as Catastrophic and the serious degree is 10.

2) Level B (High): Collision or Oil Leakage

The shuttle tanker changes the heading angle and reduces speed successfully, but still contact with FPSO. Assumption is that there is only limited structure astern damage and no leakage gas and oil, or the loading hose break and oil pollution to the sea. The serious degree is 6.

3) Level C (Light): Near-miss or Loss Time

The collision does not happen, but the offloading activity stops. The serious degree is 4.

4) Level D (Safe): An Excursion

Shuttle tanker does not head on the collision course with FPSO, and offloading does not stop. The serious degree is 0.

3.6.5 Risk Picture

Risk Picture or Risk Spectrum is a list of all the accident scenarios together with the relative consequences and frequencies (Rausand, 2011). This chapter presents the risk pictures of three different layouts.

1) Shuttle tanker keep heading to the stern of FPSO and 80m distance to FPSO

The risk picture for the layout 1 collision scenario is shown as Appendix IV. It displays 13 consequences with risk. The summary of result is shown as Table 2 below,

Table 2 Risk Picture for Layout 1

	Conseq.	Freq.	Conseq.	Freq.	Total	Percentage
Collision	Level A	4.54E-04	Level B	7.96E-05	5.34E-04	0.593
Non-collision	Level C	1.07E-04	Level D	2.59E-04	3.66E-04	0.407

The frequency of collision is 5.34E-04 similar to 5.4E-04, which is the collision frequency at NCS from 1995 to 2013 (Lundborg, 2014). In addition, probability of collision when drive-off happen is 0.593 is a little more than 0.5. As the result show, the data assumption and function event is reasonable.

The most serious collision is 4.54E-04, which is the highest among the four result,

since the weight of tanker even without any loading is thousands tons and collision energy and result is easy to reach a serious level. Meanwhile the Level B collision is minimum among the four. In the layout 1 condition, to avoid collision by PFM on collision course is quite difficult, since the frequency is only 1.07E-04.

2) Shuttle tanker keeps heading to the stern of FPSO and 150m distance to FPSO

The risk picture for the layout 2 collision scenario is as Appendix IV. It displays 13 consequences with risk. The summary of result is as Table 3 below,

Table 3 Risk Picture for Layout 2

	Conseq.	Freq.	Conseq.	Freq.	Total	Percentage
Collision	Level A	2.48E-04	Level B	1.85E-04	4.33E-04	0.481
Non-collision	Level C	1.76E-04	Level D	2.92E-04	4.67E-04	0.519

The assumption probability of the function event F2, F3 and F5 has been decreased from 0.6/0.5/0.2 to 0.2/0.2/0.1 respectively, since the longer distance, the longer time window for drive-off detection, and successful recovery. And the frequency of the collision has decrease 18.9% from 5.34E-04 to 4.33E-04. It is a great reduction, but the result is still at 1E-04 level, and still cannot be acceptable. In addition, this kind of offloading method should increase the length of the loading hose of the existing FPSO. It requires the FPSO running company to invest more to modify the hose reel and the structure around. The cost for modification and loss working time would be more than a certain amount. The cost effectiveness should be considered.

3) Shuttle tanker keep deviation angle heading to the stern of FPSO

The risk picture for the layout 3 collision scenario is as Appendix IV. It displays 13 consequences with risk. The summary of result is as Table 4 below,

Table 4 Risk Picture for Layout 3

	Conseq.	Freq.	Conseq.	Freq.	Total	Percentage
Collision	Level A	1.86E-05	Level B	2.95E-05	4.81E-05	0.053
Non-collision	Level C	1.30E-04	Level D	7.22E-04	8.52E-04	0.947

The assumption probability of the function events is modified according to the layout 3. The heading of vessel does not direct to the FPSO, so the possibility of F1 invert from 0.6 to 0.4. And the separation distance increase from 150m to 250m, therefore

F2, F3, F5, F6 and F7 has been decreased from 0.6/0.5/0.2/0.6/0.51 to 0.1/0.1/0.1/0.1/0.3 respectively, since the longer distance, the longer time window for drive-off detection, and successful recovery. And the frequency of the collision has decrease 91% from 5.34E-04 to 4.81E-05. It is a great reduction.

Chapter 4 Bayesian Risk Influence and Decision Support Diagram

4.1 Theory of Risk Influence and Decision Support Diagram and Introduction of GeNIe Software

Risk influence diagram is an acyclic directed graph representing decision problems. The goal of influence diagram is to select a decision. It is similar to Bayesian networks, and is used to show the structure of the decision problem. The influence diagram contains four types of nodes, and they are Decision, Chance, Deterministic, and Value, and two types of arcs, influence and information arcs. (GeNIe, 2015)

Decision support system is applicable to problems including classification, prediction and diagnosis, and is to model real-world decision problem using theoretically sound and practically invaluable methods of probability theory and decision theory. It can present the problem structure in graphical way and combine expert opinions with frequency data, gather, manage, and process information to arrive at intelligent solutions. The system is based on a philosophically different principle than rule-based expert systems. While the latter attempt to model the reasoning of a human expert. (GeNIe, 2015)

GeNIe is a development environment for building graphical decision-theoretic models and can promote decision-theoretic methods in decision support systems. It allows for building models of any size and complexity, limiting only by the capacity of the operating memory of your computer. It is developed at the Decision Systems Laboratory, University of Pittsburgh (GeNIe, 2015).

4.2 Construction of Diagram for Collision Scenario

In the Chapter 3.5, an event tree is used to describe the scenario of drive-off. When

the drive-off happens, the DPO normally take three aspects of actions to avoid collision, and they are heading direction or propulsion power and direction, and change DP mode to manual mode, as the Figure 18.

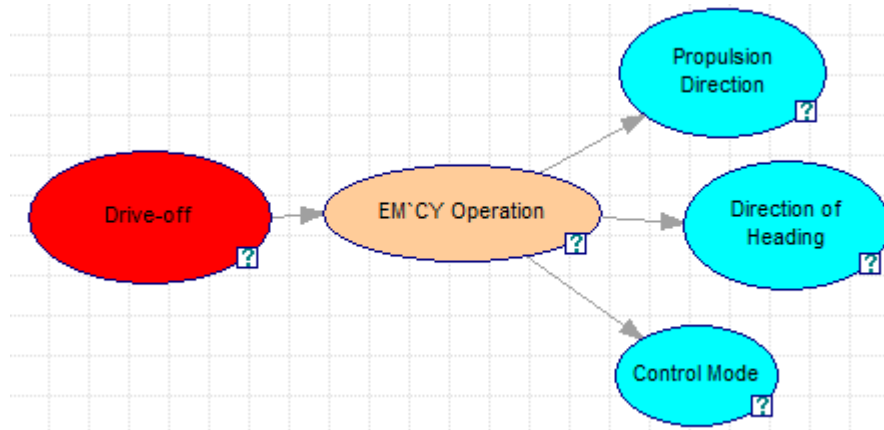

Figure 18 Decision Diagram for Drive-off

A. The Risk Influence Factor to Drive-off and Evidence

As the FTA, five factors can influence on the Drive-off, and they are DP control system, propulsion system, human error, DP control system, PRS and sensor systems. They cause drive-off in single or combination ways. As the evidences of drive-off, the speed produced by the propulsion power or direction is not consistence with the environment load requirement. As there is not permanent direction of drive-off, so the consequences are on the collision course to FPSO and off the collision course to FPSO. Therefore, the drive-off part is as the Figure 19.

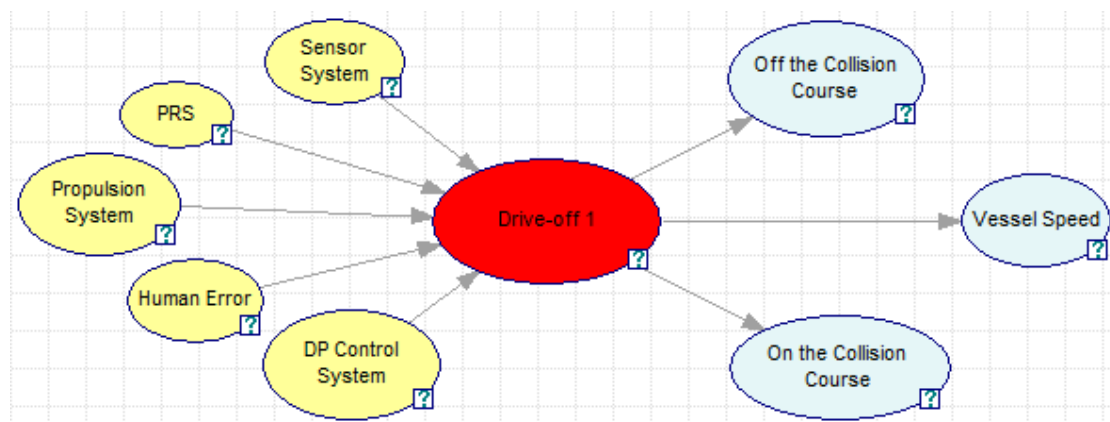

Figure 19 Risk Influence Factor to Drive-off and Evidence

B. Countermeasures selection to deal with Drive-off

There are total 18 choices of combination countermeasures to deal with drive-off as Table 5. The Bayesian Risk Influence and Decision Support Diagram is introduced to select the best countermeasure from 18 options according to risk influence factors.

Table 5 Countermeasures to Deal with Drive-off

Number	measure	Operation Mode	Heading Turn	Propulsion
1	Joystick	Joystick	Port	Keep Speed
2	Joystick	Joystick	Port	Opposite Propulsion
3	Joystick	Joystick	Port	Stop Propulsion
4	Joystick	Joystick	Steady	Keep Speed
5	Joystick	Joystick	Steady	Opposite Propulsion
6	Joystick	Joystick	Steady	Stop Propulsion
7	Joystick	Joystick	STBD	Keep Speed
8	Joystick	Joystick	STBD	Opposite Propulsion
9	Joystick	Joystick	STBD	Stop Propulsion
10	Manual	Manual	Port	Keep Speed
11	Manual	Manual	Port	Opposite Propulsion
12	Manual	Manual	Port	Stop Propulsion
13	Manual	Manual	Steady	Keep Speed
14	Manual	Manual	Steady	Opposite Propulsion
15	Manual	Manual	Steady	Stop Propulsion
16	Manual	Manual	STBD	Keep Speed
17	Manual	Manual	STBD	Opposite Propulsion
18	Manual	Manual	STBD	Stop Propulsion

The diagram, as Figure 20, presents the relationship of the choice and actions. The node in green color is the decision node.

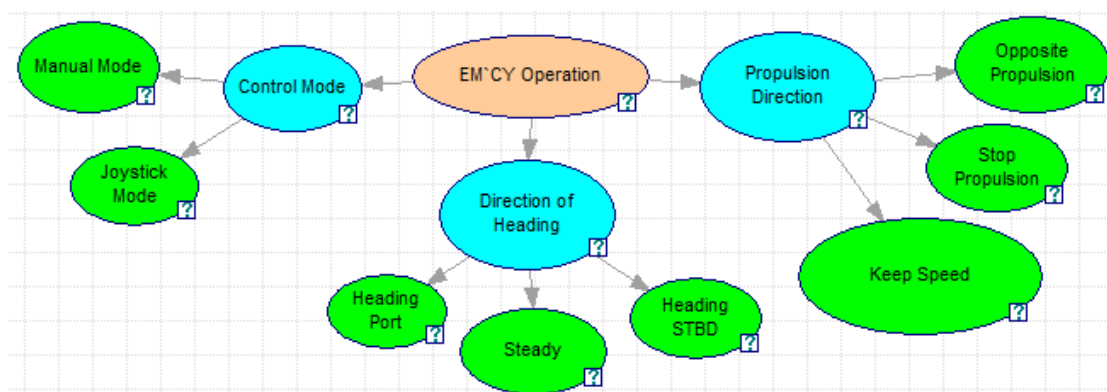

Figure 20 Countermeasures selection to deal with Drive-off

C. Influence factor to operation mode

There are three factors, as the Figure 20 presents, to influence on the successful mode changing from DP mode to manual operation mode. They are the availability to change to two manual modes and the reliability of DPO. With the DPO fail to take action, the vessel cannot change to manual mode obviously. The manual lever control mode is the first priority, since when the ST in DP joystick mode, the maximum output power is 80% limited. In addition, the propulsion power output is controlled by mathematical model and DPC. It will affect on the efficiency and maneuvering ability of ST. So to change to DP joystick mode is only when the manual lever control mode is unavailable.

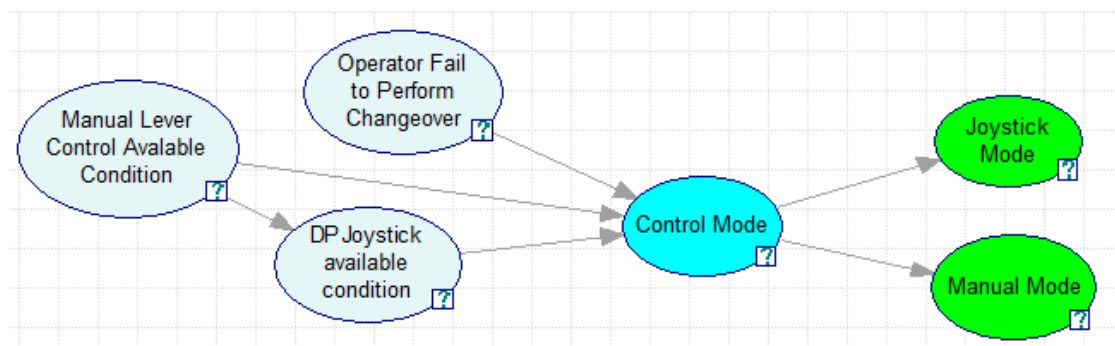

Figure 21 Influence factor to operation mode

D. Risk influence factors to Direction of Heading when vessel is on the collision course

There are two groups of factors to influence on the direction of heading as Figure presents. One group is equipment available condition, which is an indication of the ability to turn heading, and the other one group of influencing factor is the heading direction to turn.

As introduction previous, there are two tunnel thrusters, two azimuth thrusters and one rudder to control the heading. With none of them available, the vessel loses the heading control ability and can only keep the drive-off heading. The lateral force of Schilling rudder is affected by the vessel speed and turning angle. When the vessel speed is low, the lateral force is near to zero (Becker, 2016). Therefore, with the ST drive-off forward to FPSO, ST should not reduce speed to reduce the rudder force and heading changing ability of ST

The heading direction that the DPO choose to turn is based on the logic of the importance sequence, life, vessel, and environment (SMSC, 2016). When there is no enough space and time for vessel turning before collision, the first important factor is the position of flare tower, and second one is oil loading hose. At the North Sea, the flare tower of FPSO is installed at the stern normally as the Figure 1 and Figure 3 presents. When the vessel is impossible to avoid collision, the ST should avoid striking on the flare tower of the FPSO. With the flare tower collapse, serious fire and explosion will happen. Human life, vessel and environment would be all under great damage. The last one is to avoid the offloading hose to avoid oil spill after hose rupture due to collision. When there is enough space and time for vessel turning before collision, the first important factor is to keep vessel heading same with the environment load direction, since it could help the vessel turning and increase the probability to avoid collision. Second, there is normally at least one standby vessel for area based emergency preparedness (Vinnem, 2015) and several PSV or other working vessel in addition. So the avoiding collision course with FPSO should also avoid collision with other vessel nearby.

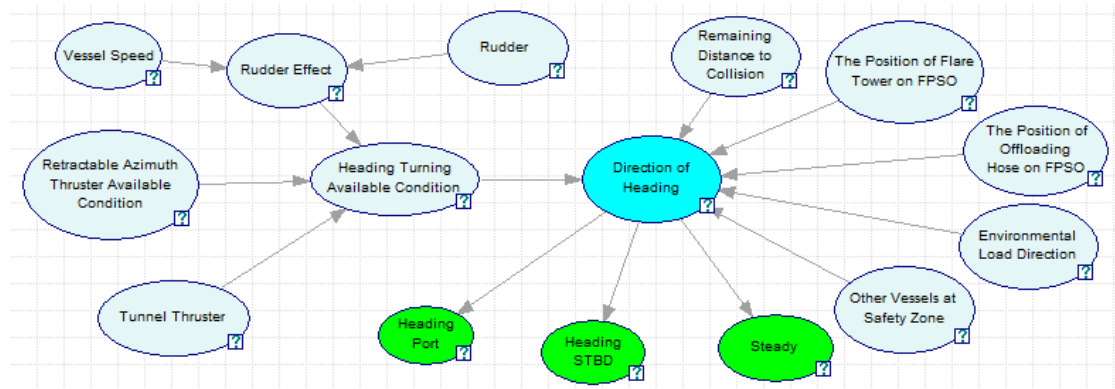

Figure 22 Risk influence factors to Direction of Heading when vessel is on the collision course

E. Risk influence factors to Direction of Propulsion

There are two groups of factors to influence on the direction of propulsion as Figure 23 presents. Equipment available condition is an indication of the ability to provide propulsion power. There are two azimuth thrusters and one engine-shaft-propeller system. With none of them functioning, the vessel cannot provide propulsion power.

The other group with four factors influences the direction. And they are the rudder effect, vessel loading condition, drive-off speed, remaining distance to drive-off. As it mentions previously, the vessel speed could have a great effect on rudder turning efficiency. When the ST should turn the heading, the speed should increase instead of decrease, and the propulsion direction should not change to opposite direction. But when the vessel in light loading condition, quite low speed, the DPO detect the drive-off just after it happens and there is no possibility to collision with FPSO, the ST could start Opposite Propulsion to stop drive-off. It could save the offloading time.

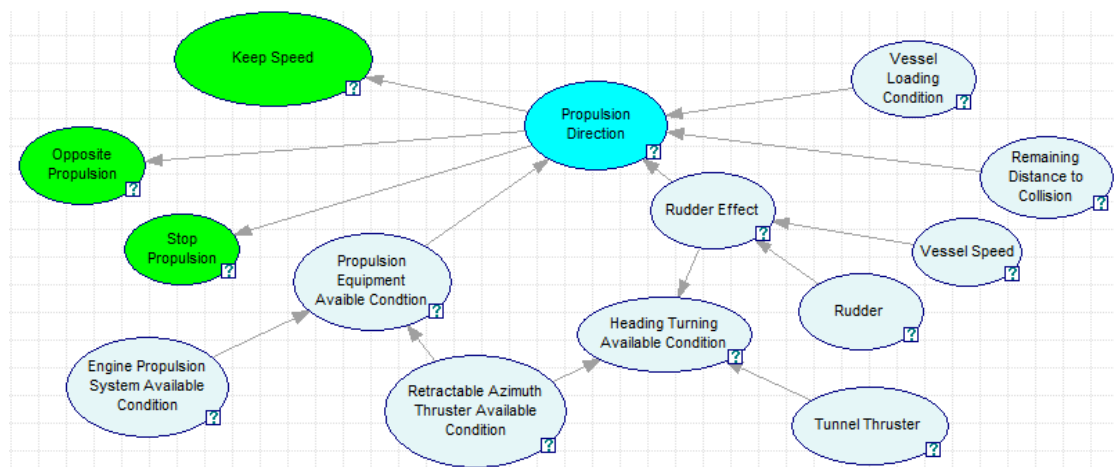

Figure 23 Risk influence factors to Direction of Propulsion

F. Drive-off but not on the collision course with FPSO

When the vessel drive-off is off the collision course to the FPSO, Opposite Propulsion can act with the functioning of the propulsion system. And the ST should emergency shutdown or stop propulsion, when ST is impossible to provide the Opposite Propulsion to reduce the drive-off distance. The factors relationship presents as the Figure 24.

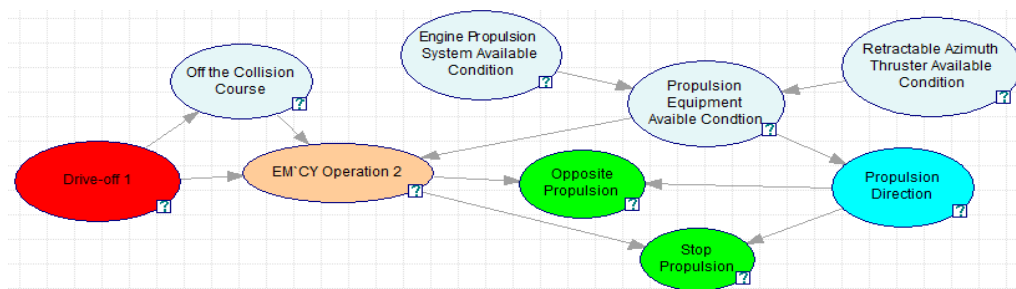

Figure 24 Drive-off but not on the collision course with FPSO

The whole decision diagram refers to the Appendix V.

4.2 Condition Decision Table

A Decision condition table as Appendix VI is constructed to give detail ship maneuvering decision according to the decision logic in previous chapter. With an “x” symbol in the block, it means this column is true. Taking No.1 scenario in direction of heading table as a decision example, E (Direction of Heading | Drive-off on collision course = true, Heading turning Equipment Condition Available = true, Remaining distance to FPSO is not enough for collision avoidance operation = true, Position of flare tower is Port = true) = Port.

4.3 Contingency Plan for Drive-off

Contingency Plan is used to provide an operation procedure for operator to deal with an emergency condition to reduce the impact of accident to life, environment and property. As previous introduction, the drive-off of ST could collide with FPSO with critical high potential and serious result. Every single second is critical to successful recovery. But there is not specific contingency plan for DPO to follow. In addition, there are five thrusters and one rudder. During or before the process of recovery, the thrusters and rudder are perhaps in different degradation or failure conditions, a plan to manipulate the remaining variable equipments smartly and swiftly to achieve a better recovery performance should be prepared in advance. The function of ORDSS is required to give control order to all thrusters and rudder to avoid collision. Furthermore, there are a Senior DPO and a DPO working at bridge during offloading operation, and they shift the duty of DP operation every hour. It is time-saving to attribute the responsibility and set the leading role by the contingency procedure in advance. So a contingency plan is necessary.

The design logic of contingency plan is to follow the importance order, “Life, Ship, Environment and Save offloading Time Loss”. This sequence decides the sequence of

actions. There is no question that life should be on the top priority. The oil tanker and FPSO both contain tens of thousands of barrels of oil and easy-ignited gas. If the integrity of the vessel cannot be guaranteed, the environment is polluted definitely.

The procedure explanation of plan is as table 8 and below,

Table 6 Operation Steps and Responsibility Distribution

	Senior DPO	DPO
Step 1	The Duty DPO detects the vessel drive-off and informs the other DPO and they confirm whether the vessel can stop before ESD 2 or not	
Step 2	Maneuver the vessel to turn the vessel off the collision course according predefined procedure	<ol style="list-style-type: none"> 1. Inform the sailors working in bow offloading room, FPSO control room to withdraw the people working at the stern area 2. Active ESD 2 3. Inform engineer in engine control room to pay attention to the health condition of engines and switchboard, arrange one person to the Steering-gear Room for emergency manual operation of rudder, and no one is allowed take any operation in engine room without order from bridge. 4. Inform all vessels in the safety zone to pay attention to leave the emergency maneuvering course of ST
Step 3	Observe	
Step 4	Give order to DPO to maneuver the vessel to keep same speed at bow and stern and away from FPSO further, ship alongside face to environment load	Execute Sr. DPO order
Step 5	Observe. If the collision is unavoidable, DPO should inform all crew to prepare fire fighting and prevent oil pollution.	

Step 1: The Duty DPO detects the vessel drive-off and informs the other DPO and confirms whether the vessel can stop before ESD 2 or not

The bridge team management is to transfer the latest information about a new situation to each other.

Since the DP drive-off alarm is based on a pre-set speed and ST is under surging movement, it is impossible to stop vessel in such a short distance, when a vessel has already gained a speed. It takes certain time to build up the speed due to the vessel

inertia. With ORDSS install onboard, DPO can detect drive-off before or at the critical point of start. An astern propulsion or emergency shutdown to stop the vessel movement is possible. It could save offloading time loss.

Step 2: DPO inform the relevant persons and active ESD 2. Senior DP takes action to maneuver the vessel to turn the vessel off the collision course

In case there is only one DPO at bridge at the moment of drive-off, the DPO should inform the relevant person at bow offloading room, FPSO astern to escape according to the policy of Life, Vessel and Environment, maneuver the vessel, and active ESD 2.

The heading changing of ST is based on the chapter 4.2. The details of thrusters and rudder refer to the Appendix VII.

Step 3: Sr. DPO observes condition after maneuvering action execution. DPO wait for DPO further maneuvering order

Step 4: Sr. DPO order the second vessel maneuvering order to keep the ST away from FPSO

When heading of ST is off the collision course with FPSO, the ST should keep away from the FPSO, especially the stern. The stern of ST is still speed up to the FPSO, due to heading change. A second order should make stern go to the opposite direction by changing the propulsion of Aft Thruster, Azimuth Thruster or even rudder to provide opposite force, and prevent heading from going back at same time by Bow Thruster or Fwd Azimuth Thruster. As strong wind and rough sea is quite normal at North Sea, using environment force to assist heading is also considered here. The detail operation procedure is as the Appendix VI

Step 5: Sr. DPO observe. If the collision is unavoidable, DPO should inform all crew to prepare fire fighting and prevent oil pollution.

Chapter 5 Online Risk Decision Support System

Preparedness ensures success, unpreparedness spells failure.

-Doctrine of the Mean

A qualified navigator should sense and evaluate the environment changing and prepare the emergency operation plan all the time during his or her operation duty. This word is given by Mr. Gunnar Gudmundseth, who is a senior captain, senior inspector of Norway Maritime Authority, and DP Operation Training Instructor in Ship Modeling& Simulation Center. How to steer a fifty-thousand ton “powder barrel”, oil tanker, to avoid bomb with another hundred-thousand ton “powder barrel”, FPSO, can bring serious uncomfortable stomach and shaking body, when a DPO cannot see any space between ST and FPSO. Definitely, the only way is to improve the situation awareness of DPO, to prepare the contingency plan, and to simulate in mind to see its possibility to success. However, DP operation is 99% boredom at normal operation and 1% panic at emergency situation (Chen, 2006). Therefore, a stand-alone system, Online Risk Decision Support System (ORDSS), to monitor the DP system, environment and DPO operation is needed to improve probability of successful drive-off recovery and bring a more convenient DP operation situation.

5.1 System Concept

ORDSS is a proactive and reactive system. It is a software-based and self-learning system working as an extra safety barrier parallel to DPO function (Vinnem and Utne, 2015). The relationship among DP system, ORDSS, and DPO is as the safety barrier diagram, Figure 25. The system aims to increase the level of automation and autonomy in the loop of DP operation to reduce manual operation and intervention and the probability of DP system fault as one proactive barrier. And it also provides longer response time and increases the probability of successful recovery from Drive-off as one reactive barrier (Vinnem and Utne, 2015).

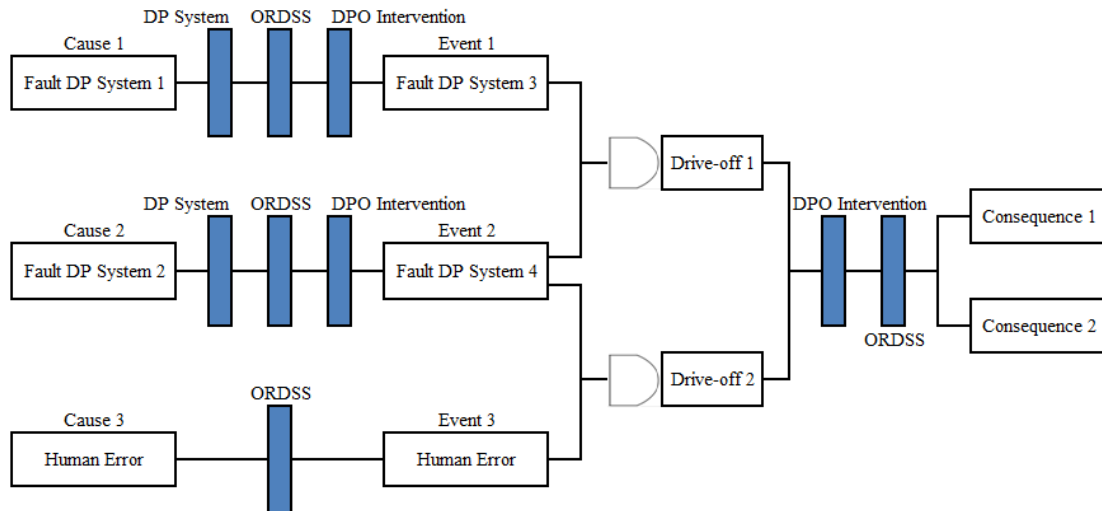

Figure 25 DP system, ORDSS and DPO as Safety Barrier

As the FTA previously, position loss is normally caused by two fault combination, for example, a PRS fault, which a PRS component fault with a DPC system fault happens at same time usually. A new barrier is inserted between the causes, DP system fault, to monitor and provide warning of the system control logical fault and the possibility of a component fault. In addition, it can give a pre-warning to DPO, when an operation does not comply with operation rules or practice by simulation function. When the drive-off happens, the ORDSS can analyze the real conditions, both system and environment, and operate the thrusters and rudders with optimization recovery plan automatically. It aims to increase the time window and successful recovery rate.

With the system description above, its function covers the tasks as below,

- A. To predict and indicate the failure rate of the components from DP in real time
- B. To early predict and indicate the probability level for drive-off in real time
- C. To simulate the DPO intervention
- D. To issue Drive-off alarm
- E. To calculate and indicate the relative parameters about collision such as remaining recover time, collision causes, etc.
- F. To draft, simulate, evaluate, and execute the recovery plan, and monitor executing
- G. To learn and store the recovery operation, and as a reference for next operation

5.2 System Structure

The functions are integrated into four system as Figure 25, and they are Situation Awareness System including Data Analysis Model in blue, Drive-off Monitoring and Alarm system including the risk model of DP Operation in red, Decision Support & Simulation System including Bayesian Risk Influence Decision Support Model and Countermeasure Evaluation and Simulation system with in yellow, and Countermeasure Executing Monitoring system in orange, and a HMI system.

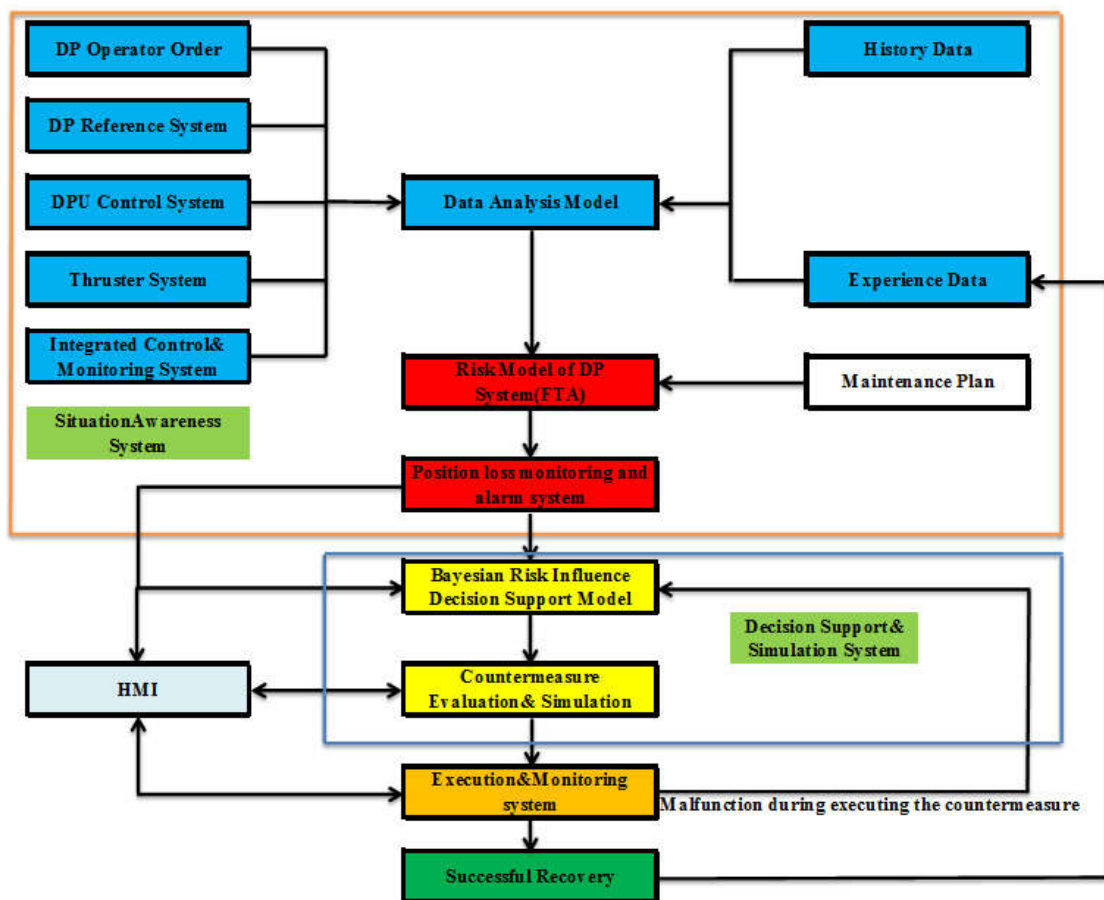

Figure 26 Structure of ORDSS

A. Situation Awareness system

Situation Awareness module collects and analyzes all the information relative to drive-off and warning the DPO with the three degree of the process to drive-off, Drive-off in red, Potential High in yellow, and Safe in green on the screen of HMI.

- Data Analysis Model

The Data Analysis model collects data information and analyzes the failure rate and working condition of components. The data sources come from two parts, the real time data and previous data. The real time data comes from PRS, DPC units, thruster systems, Integrated Control& Alarm System (ICAS) and DPO intervention orders. The monitoring points are decided by FTA and output digital and analog signal. The previous data is history data and experience data. The history data is the recording of daily normal operation and reliability data for example, mean time to failure (MTTF) and the experience data is the emergency operation about successful and unsuccessful recovery operations. All of these data input to the Data Analysis Modeling to provide a real time failure rate of a single component.

- Drive-off Monitoring and Alarm subsystem

This system predicates the possibility of drive-off, figures out the reasons to contribute to the drive-off and to transfer the analysis results to HMI. The risk model is introduced in chapter 3. Equipment availability and reliability due to maintenance is considered. It uses the output from Data Analysis Model and maintenance plan as the data source to input into the basic event of the FTA model in chapter 3.3.

B. Decision Support and Simulation System

This subsystem comes into function directly, when it receive the drive-off alarm from Drive-off Monitoring and Alarm subsystem. It will first scan and collect the data about the availability of the propulsion system including engine system, thruster system and rudder system, operation station, and available electrical power and environment load condition through maintenance plan and ICMS. The data inputs into the Bayesian Risk Influence Model to generate an optimal recovery plan. The plan is to demonstrate on HMI to inform DPO and to be confirmed by DPO or be executed directly.

The countermeasure selected by Decision support system will be simulated by model of available time window and vessel's trace, and demonstrate the vessel trace on the HMI screen to DPO for further decision.

There are ten different automation levels (Parasuraman. 2000), and the automation level of the ORDSS should start from level 6 (Vinnem and Utne, 2015). And the explanation from level 6 to level 10 is as below,

6. The computer provides time for the operator to reject execution
7. The computer takes action automatically, but may inform the human operator
8. The computer informs the human operator, if enquiry is made
9. The computer gives information to the operator if it decides that it is necessary
10. The computer makes all decisions and overlooks the operator.

C. Countermeasure Executing and Monitoring System

Countermeasure executing process and condition is monitored by the system. It functions same as the DPO observe the process and result, when the emergency operation has been committed. If a fault happens during the executing, all the latest data input to the Decision Support and Simulation System to analysis again. With a successful recovery, the operation procedure, environment load condition and system condition are recorded as a reserved file and used as a reference. And the countermeasure executing process is demonstrated on the HMI for DPO monitoring.

5.3 The Modeling of Data Analysis on DP System, Operator and Environment

The quantity analysis of the drive-off is based on the data about the possibility to fault (failure rate) of each component and activities in the basic event of the fault tree. For the online risk analysis, the inputting failure rate to the FTA is a real time dynamic data instead of historical data, such as constant experience data or experiment data from handbook.

There are three types of basic data in the basic event of fault tree according to data source, and they are environment data, real time dynamic human reliability data and DP system running data. The environment data and running data can be collected by sensors and DP system internal data transportation. Although there is no sensor

designed for DPO to measure their dynamic human reliability data, their intervention to DP system is measurable.

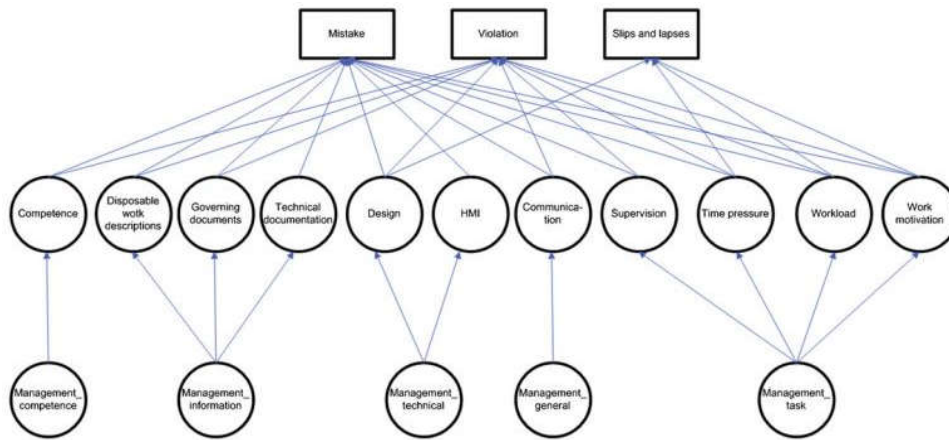

Figure 27 Generic RIF model for execution and control activities (Vinnem, 2011)

The operation error is fault intervention to the DP system. The structure and relationship among human error and RIFs are shown as Figure 27. Level 1 includes RIFs with a theoretically and empirically justified influence on the failure type violations, mistakes or slips and lapses. Level 2 presents different aspects of management that influence the RIFs on Level 1 (Vinnem, 2011). But there is no any sensor to measure these factors and to generate a real time data to input into ORDSS. Only after the intervention is done, can the action of intervention transform into a signal through the HMI of DP system, for example selecting an operation mode is same as a switch on/ off or digital signal and setting a new heading is same as input analog signal. Then the fault intervention is detected. This is a postpone detection, not predication and detection punctually. To solve the problem of predication and punctual detection, the solution is to press the button with confirmation activity. The design of DP operation system now is to select or deselect an operation mode by pressing the button two times. The aim is to avoid pressing the button by mistake. After the DPO input information into DP system, the ORDSS display the vessel response on the operation screen, and pick up this operation signal into Data Analysis mode to analysis. If the operation can cause drive-off, the operation will indicate as a reason of drive-off on the operation interface and to give a warning. The ORDSS has detected fault DPO operation. If the DPO confirm the information, ORDSS will issue

a drive-off alarm.

The Integrated Intelligent Model is introduced, and it is used to detect the process state, especially for fault, and behavior prediction (failure rate) according to process input and historical output. It combines the influence caused by the final results of process state (fault) detection and quantitative prediction, the failure rate of single component. Three Artificial Neural Networks (ANN) models are used for system identification of process characteristics in different process states. The whole model is developed basing on Fuzzy TS dynamic Nonlinear AutoRegressive with eXogenous input models (NARX models) (Tang, 2004). This intelligent mode has been tested by study-prediction case for supply chain process. With a four-year data study, it can predict the fifth-year operation data, and the rate of average relative error is 0.21. Therefore it can be used to calculate the online failure rate data by computation software and input into the FTA (Tang, 2004).

5.3.1 The Construction of Integrated Intelligent Model

There are five units in Integrated Intelligent Model. Each unit has a special function and sub-models. The construction of the model is shown as Figure 28.

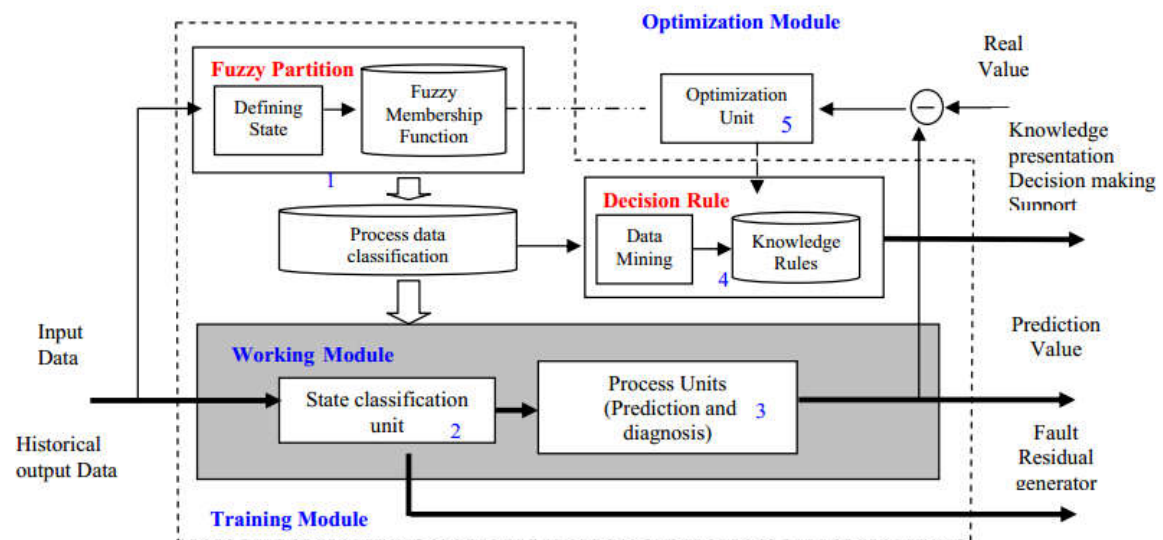

Figure 28 Construction of Integrated Intelligent Model

This model consists of three modules. The Training module functions as building model by learning from historical data. The Working module functions as processing

diagnosis and prediction. The Optimization module functions as optimal model and model adaptability (Tang, 2004). The input data are the real time data and the historical data. And there are three outputs, the knowledge presentation decision making support, prediction value and the fault residual generator. The fault residual signal is generated to detect the fault event by the system.

5.3.2 Application in Failure Status Prediction

The relative system sensor can pick-up the real time data as input 1. And the history data can withdrawn from the Voyage Data Recorder, which is a equipment to record down all the component running data like the black box carried on aircraft. In addition, the failure rate that is calculated from MTTF can get from manufacture reliability manual. The history data is as input 2.

The mode is established from history data learning. And the Integrated Intelligent Model combining the variable input 1 and input 2 is described as a fuzzy TS NARX dynamic mode as Figure 29. It includes fuzzyfication, applying fuzzy operation, applying implication, aggregation, defuzzify and predication output Y. The Z_{11} & Z_{21} represent that Input 1& Input 2 output an error or fault state and The Z_{12} & Z_{22} represent that Input 1& Input 2 output a normal state. And w_i is the fuzzy degree in relation to different process states.

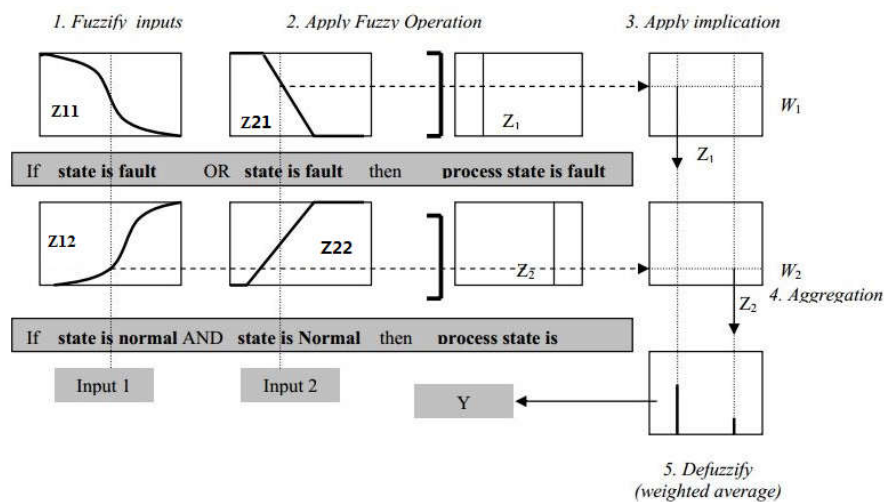

Figure 29 Fuzzy TS NARX dynamic Mode

Therefore, the output failure rate combining the real time data and historical data is as

formula

$$Y_{\text{total}} = aY_{\text{Input 1}} + bY_{\text{Input 2}} + c = a(w_{11}Z_{11} + w_{12}Z_{12}) + b(w_{21}Z_{21} + w_{22}Z_{22}) + c$$

And a and b is the affection degree of input 1 and input 2 to the whole process of output. And through the historical data learning, the a, b, c and w_i can result with a constant value.

5.4 Modeling of Available Time Window for Successful Recovery and Vessel Trace

With the vessel on the collision course, the known time window and estimation trace of vessel can assist the DPO to prepare a better countermeasure plan and estimate the collision condition or only near-miss. As the real condition, the propulsion force and hydro-resistance are influence by the variable vessel speed and environment load is changing all the time. Therefore, it is difficult for DPO to calculate a relative accurate remaining time. Figure 30, which is an idealized simulations are made in the still water case presents a speed-time plot of simulation of shuttle tanker drive-off (Chen, 2004). The distance of drive-off is the area between the velocity and time axis, and the time remaining is relative to the distance remaining and the velocity that is related to the acceleration decided by the propulsion force, environment force and hydro-resistance on vessel.

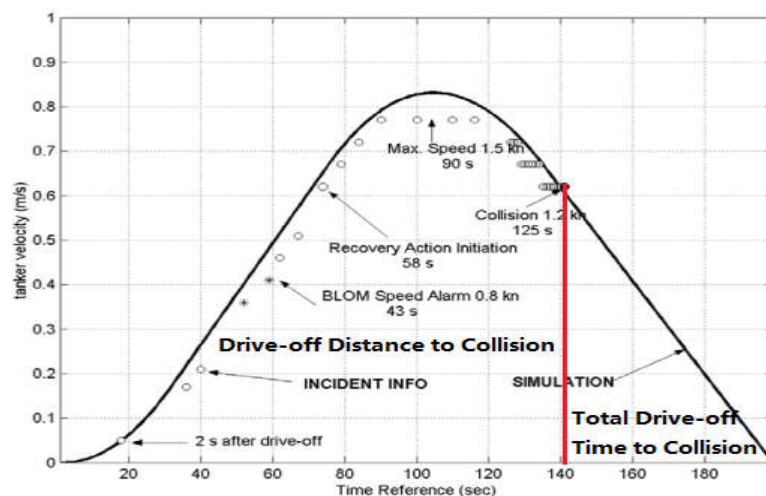

Figure 30 Speed-time plot of simulation of shuttle tanker drive-off (Chen, 2004)

The propulsion force and hydro-resistance are the factor influenced by vessel speed (Steen, 2015). Therefore, all the factors are nonlinear value. The time remaining calculation is based on amount of certain time intervals. And the minimum time interval is decided by the maximum relative data update time interval. An assumption of the time interval here is 1 second. The relationship among the vessel acceleration, speed, remaining distance and forces on vessel is as below.

The forces on vessel and acceleration at time t_i

$$F_T(v(t_i)) - R_{TS}(v(t_i)) - F_{En}(t_i) = ma(t_i)$$

$F_T(v(t_i))$: Variable thruster force related to vessel speed

$R_{TS}(v(t_i))$: Variable resistance force related to vessel speed

$F_{En}(t_i)$: Environment Load at t_i

m : Vessel mass including loading cargo at t_i

$a(t_i)$: Acceleration at t_i

$v(t_i)$: Speed at t_i

Speed in next period of time t_{i+1}

$$v_{i+1} = v_i + a(t_{i+1}) * t_{i+1}$$

The distance of drive-off in a period of time

$$S_{i+1} = v_i * t_{i+1} + a(t_{i+1}) * t_{i+1}^2 / 2$$

The total distance

$$S_{tot} = \sum_{i=0} S_{i+1}$$

The remaining time to collision

$$T = \sum_{i=0} t_{i+1}$$

It is impossible to measure the environment load of next second, so the remaining

time calculation is based on the assumption of a constant environment load at the measured interval. And the remaining time is updated after all data updated.

$F_T(v(t_i))$ is related to engine power, vessel speed, shaft efficiency, rotation efficiency and propeller efficiency. $R_{Ts}(v(t_i))$ is related to total resistance coefficient, density of fluid, vessel speed and wetted surface area. All types of the efficiency, resistance coefficient and density of fluid are a stable known value in ship design phase. Engine power, vessel speed, environment load can input directly from ICAS or DP system and wetted surface area and vessel mass including loading cargo can input directly from cargo loading computer on real time. The detail formulas relative to propulsion force and resistance can refer to the Appendix IX.

There is one case of drive-off caused by the wind sensor. In this case, the environment load is calculated based on the inputting of wind sensor one second before failure.

5.5 FTA as the Node of Bayesian Risk Influence and Decision Support Diagram

In the chapter 3.5.3, all the function events are simple basic events with a fixed possibility, and the possibility, an expect value, of the event calculates from the accident database. But to an online system, it needs the possibility of the function event as a real time data. The result inputs into Decision Model as risk influence factor to generate the optimal countermeasures and provide a reference to the operator and ORDSS to select decisions. Therefore, the online system should use the “gate” event instead of the basic event. The gate event is a separate fault tree analysis. There are totally seven function events in the event tree. The F1 is decided by the vessel heading course on real condition. The remaining function events are analyzed below,

- F2 and F3

Kongsberg DP system can give a “Drive-off” alarm off after drive-off speed reaches to 0.2 knot, not immediately. The alarm is based on the degree that actual propulsion

power is different from the system model prediction, and it displays as a big red warning window on the OS as drive-off happen warning. But the DP system cannot indicate the drive-off reasons and recommendations to the DPO. The F2 and F3 can be removed, since the main function of ORDSS is to detect the drive-off and prepare and execute the countermeasure plan.

- F4 Fail to Manual Take-over

There are two manual operation mode from bridge, DP joystick mode and manual mode. The manual mode here is to deselect DP system and come to operation by levers. And they are as below,

A. Fail to change to Joystick mode

To press the “Joystick” button on the HMI is the most direct way to change DP mode to manual mode. However the system reaction time is slower than the manual mode, when the vessel in joystick mode. The reason of slow reaction is that DP system uses mathematical model to calculate reaction force and distributes to each thruster. In addition, there are two mode of thruster setting of the Joystick mode to selection. The output power at “Full” mode is 80% of total power and “Reduce” mode is 50% of total power. To output the highest power, the thruster setting should be set in “Full” by one more action.

There are two OSs (operator station) on the bridge. If system fails to change to joystick mode on the “Take” OS, it is possible to change to the other OS and to joystick mode.

B. Fail to change to Manual mode

To press the “Manual” button on the navigation console is the only way to change DP mode to Manual mode.

In addition, propulsion engine and rudder can operate at local and local operation is the highest priority level to control the machinery. But as the time window limitation, this operation method is not considered here.

C. Human Error

Human error could happen and fail to change due to panic or other reason. It could fail to take action to change to manual mode. The Human Error can be removed, since the main function of ORDSS is to execute the countermeasure plan. It can improve the possibility of successful recovery.

The fault tree for Fail to Manual Take-over is as the Appendix II

● Fail to Provide Propulsion

The propeller-shaft-engine system and two azimuth thrusters can provide astern propulsion. According to Pre-enter 500 m safety zone checklist, all the thrusters is at working condition or idle condition. They can provide any direction force at any time. And the main engine is running and the pitch is adjustable. Since they are two different equipments and two different working principles, it will discuss separately as below.

A. Azimuth thruster

There are three conditions that the azimuth thruster cannot provide astern propulsion. First, the thruster shut-down and cannot restart before the recovery operation. Second, the steering gear unit of azimuth thruster stuck at forward position. And the thruster cannot start again due to position stuck. Third, the azimuth thruster shut-down during working. The causes of azimuth thruster shut-down are as below,

- Main supply power loss
- Control power loss
- Main motor temperature high
- PLC failure
- Servo oil pressure low

B. Propeller-shaft-engine system

There are three conditions that the propeller-shaft-engine cannot provide astern propulsion. First, the engine shut-down and cannot restart before the recovery operation. Second, the pitch of propeller loss of control and stuck at forward position or zero condition. Third, the main engine shut-down. The causes of CPP loss of control (IMCA, 1996) are shown as below

- Aft sterntube bearing temperature high
- Forward sterntube bearing temperature high
- Hydraulic system pressure low
- Hydraulic oil system filter blocked
- CPP control unit fail
- CPP supply power loss
- CPP control power loss

The causes of main engine shut-down are as below (DNV, 2015),

- Lubrication oil into all bearing pressure low
- Over-speed protection
- Oil mist in crankcase high high

The fault tree for Fail to Manual Take-over is as the Appendix II

- Fail to Stop Forward Propulsion

When the engine or azimuth cannot provide astern propulsion, the operator should press the emergency shutdown button on the bridge console to stop the forward propulsion. And the cause of “Fail to Stop Forward Propulsion”

- Fail to Change Heading

The tunnel thruster and rudder can provide heading change force.

A. Tunnel Thruster

There are two conditions that the azimuth thruster cannot provide side propulsion.

First, the tunnel thruster shut-down and cannot restart before the recovery operation. Second, the tunnel thruster shut-down during recovery operation.

The thruster shut-down reasons are as below

- Electrical control power loss
- Main supply power loss
- Main motor high temperature

B. Rudder loss of control

The reasons of rudder fail to turn at bridge are at below (DNV,2015) TS414,

- Steering gear supply power loss
- Steering gear supply power phase failure
- Hydraulic oil temperature high
- Steering gear control power loss
- Disconnection of bridge control

The fault tree is as the Appendix II.

5.6 The Modeling of Collision effect

With different collision angles, the collision energy and the energy transfer to the FPSO from moving shuttle tanker is different. And the power distribution on astern and athwart propulsion can influence the collision result. Bow& aft thruster and azimuth thruster can both provide athwart force to turning the vessel heading off the collision course. It should decide an optimal plan to avoid collision or a collision angle and collision speed by controlling the propulsion degree of azimuth thrusters and loads on bow& aft thrusters, when collision is unavoidable. Therefore, it is important to include the modeling of collision as decision support analysis.

The energy calculation contains the following phases (Asbjørnslett, 2015):

- Defining the motions of colliding ships due to the impact forces
- Defining the accelerations relative to the contact point
- Defining the relative velocities right after the collision which can be obtained from the sway and surge velocities of colliding ships and collision angle α as Figure 30 including the velocities at the end of collision.
- Impact impulses ratio to determine if the ships stick together or slide

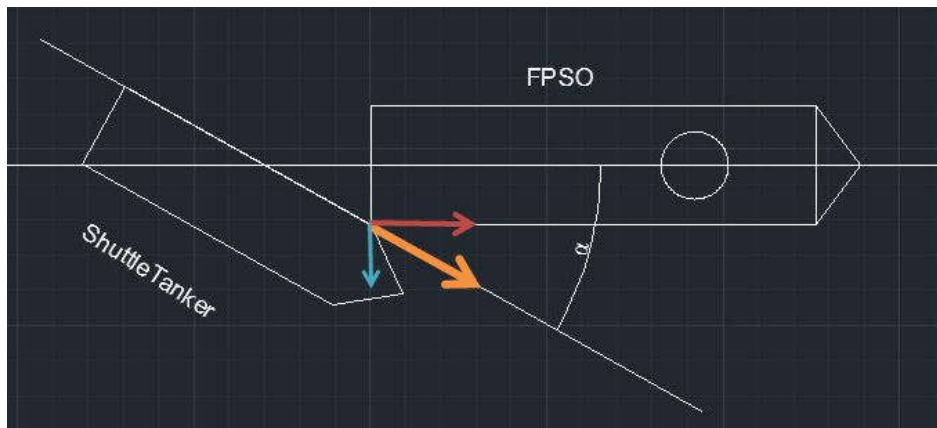

Figure 31 Picture to Demonstrate Collision Condition
Collision modeling of shuttle tanker with FPSO

The collision force can be divided into two orientation forces as Figure 31. The red color one will cause the ship deformation and surge. And the blue color one can bring the vessel rotate. After collision happened, the shuttle tanker will lose some energy and the energy will transform to Global and local vibration, which can affect the riser and mooring chain, and elastic and plastic deformation.

$$\Delta E_k = \frac{1}{2} m_b v_b^2 - \frac{1}{2} m_a v_a^2$$

ΔE_k : Loss of kinetic energy

m : Vessel mass including loading cargo

V : Impact velocity

b : Immediately before impact

a : Immediately after impact

And with theorem of momentum, it can conclude,

$$E_I = \frac{m_1 \times m_2 \times (1 + C_h)}{2(m_1 + m_2(1 + C_h))} \times (v \times \cos\alpha)$$

$$E_{t2} = E_I \times \left(\frac{1}{1 + m_1/m_2} \right)$$

E_I : Lost kinetic energy

E_{t2} : Energy transferred to FPSO

m_1 : Shuttle tanker

m_2 : FPSO

C_h : Added mass coefficient of the shuttle tanker

v : Joint speed of shuttle tanker after collision

With the collision angle α increasing, the force to the structure is decreasing. Therefore, to change the heading degree is to reduce the collision energy at the same speed and loading condition. And with the collision angle different, the collision result is different. It can vary from slight structure damage to fire and explosion

5.7 Modeling of Probability of Avoid Contact

5.7.1 Theory of Probability of Impact Collision

In the ETA, the possibility of the function event, shuttle tanker contacting with FPSO, is required to evaluate the countermeasure plan based on the real time environment condition and vessel system healthy condition. The possibility of avoid contact in real condition should be based on the real condition instead of calculation of the data from history data base. The impact collision mode is introduced based on the modeling of ship transportation risk (Asbjørnslett, 2014) shown as the figure 32.

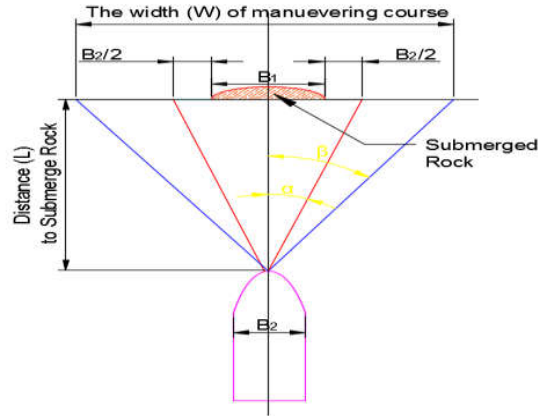

Figure 32 Risk Mode of Vessel Colliding with Rock

The geometry probability P_i in this case is as below

$$\alpha = \tan^{-1} \left(\left(\frac{B_1 + B_2}{2} \right) / L \right)$$

$$\beta = \tan^{-1} \left(\left(\frac{W}{2} \right) / L \right)$$

$$P_i = \alpha / \beta$$

B_1 & B_2 : Width of the rock and vessel

L : Distance of vessel to the rock

W : Maximum width of the navigation course to avoid impact collision with rock

The possibility of an impact accident,

$$P_a = P_c \times P_i$$

$$P_a = P_c \times \left(\tan^{-1} \left(\left(\frac{B_1 + B_2}{2} \right) / L \right) / \tan^{-1} \left(\left(\frac{W}{2} \right) / L \right) \right)$$

P_a : Probability of an impact accident per passage

P_c : Probability of losing vessel control per passage

5.7.2 Application in the drive-off scenario

With the shuttle tanker in control, the maximum navigation track of shuttle tanker is set, for example, under a certain speed, distance, loading condition, and a known weather condition, heading degree changing by rudder and thrusters, and remaining

distance to move can calculate according to the propulsion and hydro-resistance formula as the Appendix IX. And the step to apply the theory into the drive-off scenario is as below.

Step 1: Evaluate the probability to failure of the selected thruster

In the chapter 5.6, the available thrusters and rudder are used to avoid collision. The probability of equipment shutdown is analysis by the FTA. And the possibility of rudder out of control is P_{RD} . The possibilities of azimuth thruster and athwart thruster shutdown are P_{BAZ} (Bow Azimuth Thruster (BAZ)), P_{AAZ} (Aft Azimuth Thruster (AAZ)), P_{BT} (Bow Thruster (BT)), P_{AT} (Aft Thruster (AT)), and P_{ME} (Main Engine), respectively. Since the thruster manufacture is different, the constructions of equipment vary a lot. In this thesis, ABB Azipod thruster is used as an example, and the FTA is as the Appendix II.

Step 2: Evaluate the maximum of maneuvering course and collision probability of different thruster or thrusters` combination

The width of maneuvering course of different thruster can be calculated by the hydrodynamic formula in appendix IX. The result is used to compare with the width of safety zone. And Figure 31 is an example under some environment load and initial drive-off speed.

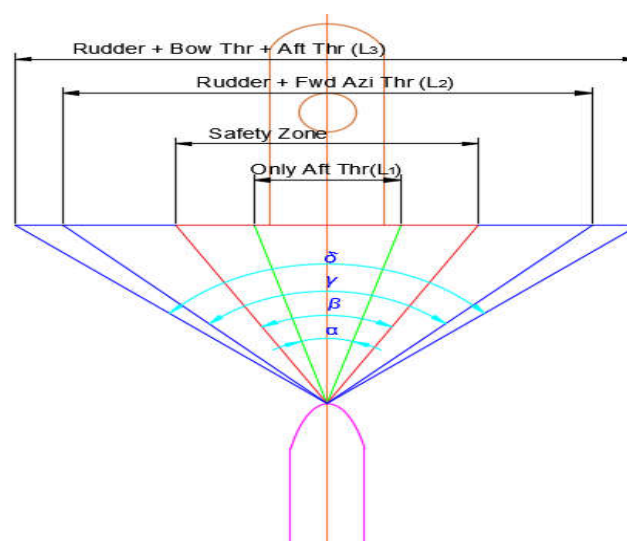

Figure 33 Width of Maneuvering Course and Safety Zone

Deploying the Aft Tunnel Thruster only, the vessel maximum course is within the safety zone and shuttle tanker will collide with FPSO at any condition of rudder function. And relevant procedure about after collision, such as fire fighting and escaping can prepare in advance. Deploying the bow or rudder, the shuttle tanker will avoid collide with FPSO at the normal working condition of the equipment. Therefore, when athwart thruster is used only, the probability of the shuttle tanker colliding with FPSO can be calculated by formula below. And it can demonstrate as

$$P_a = P_{RD} \times P_i$$

There are total 21 types of thruster and rudder combination, when all thrusters, rudder and engine are available. The collision probabilities under different thruster combination at a certain astern speed are as eight examples as below,

$$P_a = \left\{ \begin{array}{ll} P_{RD} \times P_{i-RD}, & \text{Rudder Only} \\ P_{BT} \times P_{i-BT}, & \text{BT Only} \\ \text{Collision,} & \text{AT Only} \\ P_{BAZ} \times P_{i-BAT}, & \text{BAZ Only} \\ P_{BT} \times P_{AT} \times P_{i-BT+AT}, & \text{AT and BT} \\ \dots & \\ P_{BT} \times P_{AT} \times P_{Rudder} \times P_{i-BT+AT+Rud}, & \text{AT, BT and rudder} \\ \dots & \\ P_{BT} \times P_{AT} \times P_{Rudder} \times P_{BAZ} \times P_{i-BT+AT+Rud+BAZ}, & \text{AT, BT, BAZ and rudder} \\ \dots & \\ P_{BT} \times P_{AT} \times P_{Rudder} \times P_{BAZ} \times P_{i-BT+AT+Rud+BAZ+AAZ}, & \text{AT, BT, BAZ, AAZ and rudder} \end{array} \right.$$

Step 3: Evaluate and select the countermeasure

The lowest value of probability of thruster and rudder combination is selected. If the collision is unavoidable, the ranking of countermeasure is based on the risk value $R_{Collision}$ calculated by formula,

$$R_{Collision} = P_a \times E_{t2}$$

The countermeasure with lowest risk value is selected.

5.8 HMI

The HMI is information communication between ORDSS and DPO based on computer system. There are six parts on the HMI as the Figure . On the top of the screen, they are Message indicating the status of ESD 1 & 2, escape message to the

seaman working in the Bow Offloading Room and Control Room of FPSO, Alarm relative to drive-off.

The left part of the screen indicates the ship position plots, drive-off collision course scope with shadow area, and vessel drive-off trace prediction. In addition, the indication of direction of Wind and current is as the blue and violate arrow, and the value is by m/s. The indications of total environment load and thruster output are at the bottom of left part with two different length of diagraph. At normal condition the diagraph of color for both is green. When thrust power is higher than 1.125 times of environment load and same direction, the diagraph of thrust power will turn to red color to give a warning to DPO about the deviation.

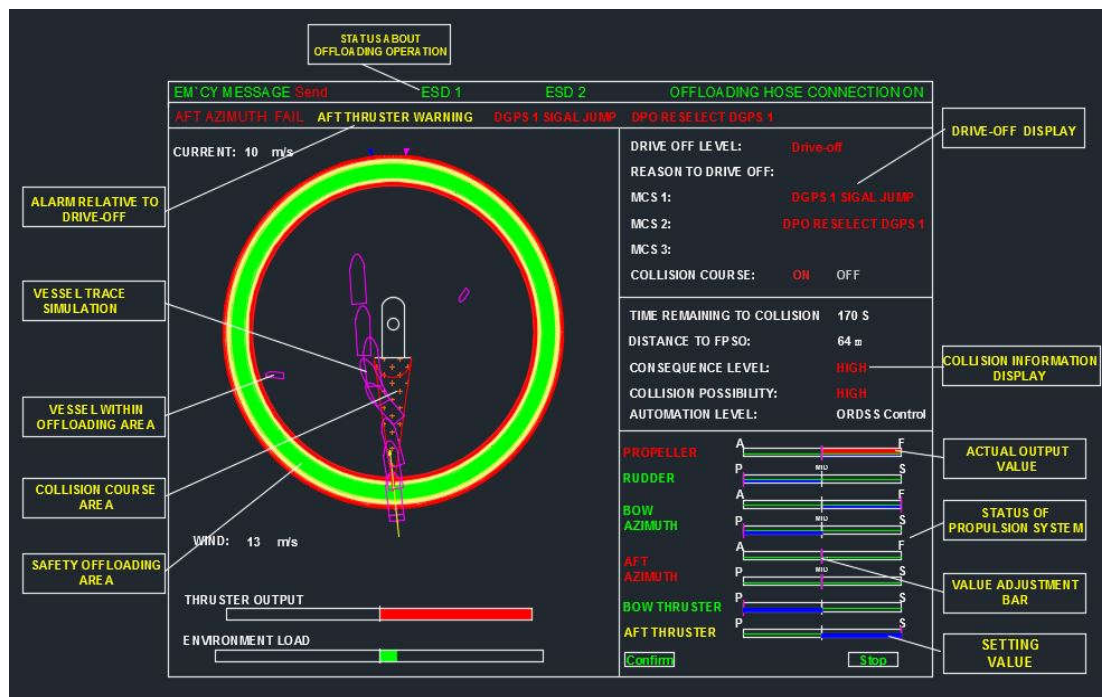

Figure 34 HMI

There are three groups of the right part of the screen, and they are drive-off prediction group, recovery information group, and availability, direction and load distribution of each thruster and rudder. The drive-off level is as introduction in previous and present in four levels with different color, Safe in green, Low Potential in Yellow, High Potential in Orange, and Drive-off in red. And the drive-off reason is display as the MCS under the reason to drive off after FTA. When the vessel drives-off on the collision course, the “ON” is in red. When the vessel drives-off off the collision

course, the “OFF” is in green. The recovery information group indicates the remaining nearest part to FPSO, the remaining time to collision, the four collision consequence level with different color, Safe in green, Low Potential in Yellow, High Potential in Orange, and serious in red. Collision possibility is from probability of avoid contact model. It has two results in different color, collision in red and avoiding contact in green. The part at right corner is the information of the thruster and rudder. The turning degree and load presents as the diagraph. And the availability of thruster and rudder system presents in three colors, available in green, abnormal in yellow, shutdown or impossible to move in red. A line in green color is separated the diagraph into two parts, the upper part is the actual output load, and the lower part is the set output load. The countermeasure plan of power distribution of each thrusters and angle of rudder presents in the lower part. With the DPO satisfied with the countermeasure plan, DPO should press the button “confirm”. During the countermeasure plan execution, if the DPO want to stop the plan, he/she can press “conceal” button. When the DPO wants to adjust the output of the thrusters and rudder, DPO can use the small bar in violate color to do the adjustment so as to perform a better action.

5.9 ORDSS Working Process

In this chapter, a drive-off case from IMCA case 1002 (IMCA, 2010) is used to test the function of Situation Awareness System, and ORDSS working process. The IMCA case 1002 presents a scenario about the hawser tensioning system signal drifting, vessel went full speed ahead to reduce the load of hawser tensioning system, ESD 1 activated and vessel stop before contact with loading bouy, but oil offloading hose was ruptured during emergency disconnection. And the whole detection and recovery to perform by ORDSS present as below.

Step 1: Warning and Alarm

The Data Analysis System detects the potential of a signal drifting by inputting history data and actual measurement into Integrated Intelligent Model. It gives a

warning and a description under MCS in yellow color. As the MCS in chapter 3.4.4 indicates, only a signal drifting of hawser tensioning system can cause drive-off. And there is a warning in yellow color indicating at ALARM Bar, and the Drive-off Level changes from green to yellow. Then the signal drifting goes further and reaches the alarm potential level, then all the information presents in yellow in previous changes to red and the drive-off level indicates “drive-off” in red to indicate the drive-off will or already happen.

Step 2: Select the available equipments and mode to operate

The FTA mentioned in Chapter 5.5 can clarify the healthy condition of manual mode, joystick mode, rudder and thruster. The result inputs as the status of the node in Bayesian Risk Influence and Decision Support Diagram.

Step 3: Decide direction of the ST movement

The direction of environment load, equipment arrangement on stern part of FPSO and the result from step 2 decide the status of the node in Bayesian Risk Influence and Decision Support Diagram. And it output the heading direction and moving forward or astern.

Step 4: Generate the available maneuvering plan and evaluate

The contingency plan can generate the available maneuvering plans to achieve the direction of the ST movement. All the plans are analysis by Collision Probability and Collision Consequence and select the best one to execute.

Step 5: Simulation

The trace of ST movement is simulated by model of available time window and for successful recovery and vessel trace model, and displays on the HMI.

Step 6: Execution

The ORDSS monitors the plan execution. And the DPO could do adjustment by the violate bar on the diagraph of angle or load of rudder and thruster so as to achieve better performance when the adjustment is necessary.

5.10 System Interface and Component Selection

As an electrical system, all the system interfaced can be divided into two groups. One is power supply system and the other one is signal communication system.

The system should have redundancy power supply. One could from main power supply line and the other should from Uninterrupted Power Supply line by battery to sustain at least 30 mins. When the vessel is blackout, the system can still work and provide decision support information to DPO.

To reduce the Capital Expenditure for new cables lying, all of the signals pick up from existing system. And the interface systems are all signal DP system including sensor system, PRS, propulsion system, mathematical model, environment load calculation, three DP control Units and Power Management System, IACS for relative component working condition including the relative data, Loading computer system for the real time displace tonnage, wet surface, and loading condition, Voyage Data Recording for experience data, AIS and ECDIS for the position of other vessel working in 500 safety zone, Doppler speed log, and Emergency Shut Down system.

5.11 Risk picture to deploy ORDSS

The risk picture for the layout 1 collision scenario is as Appendix IV, when ST installs ORDSS. It displays 13 consequences with risk. The summary of result is as Table 6 below,

Table 7 ST with ORDSS working at layout 1

	Conseq.	Freq.	Conseq.	Freq.	Total	Percentage
Collision	Level A	1.08E-05	Level B	5.33E-06	1.61E-05	0.018
Non-collision	Level C	5.24E-04	Level D	3.60E-04	8.84E-04	0.982

The assumption probability of the function event F2 and F3 has been decreased from 0.6/0.5 to 0.01/0.01 respectively, since the situation awareness system of ORDSS detects and warns DPO and provide countermeasure plan for DPO approval immediately. The probability of the function event F4, F5 and F6 has been decreased

from 0.1/ 0.2/ 0.6 to 0.0001/ 0.0001/ 0.0001 respectively, due to the automation control. Therefore the rate of avoid collision raise from 0.49 to 0.99. And the frequency of the collision has decrease 98% from 5.34E-04 to 1.61E-05.

Chapter 6 Discussion

6.1 Suitability of Risk Spectrum for FTA and ETA

- FTA

The function of Risk Spectrum as a business software covers all the requirements in the DP 2 drive-off analysis. And the advantages in FTA are as below,

1. More Logical Gate can be selected to provide a more accurate analysis in complicated logic in FTA

Except some most often seen logic gate, such as AND, OR, and KooN, There is one more logic gate called “Exactly One of the Input Events Occurs (XOR)”. It is accurate to analyze the fault of only one of two or three component fault and selected under voting logic system. And the OR gate “at least one input occurs” does present the fault tree construction clearly and accurately.

2. MCS and Top Event Probability Analysis in FTA

The software can present the number of MCS, the probability, weight, and basic event of each MCS, and rank all the MCS by the probability, and export the analysis result by Excel file. It is convenient to target to reduce the probability of several top MCSs to reduce the Top Event Probability.

In addition, the software can also provide the Uncertainty Analysis, Importance/Sensitivity Analysis and Time Dependent Analysis. These functions do not deploy in this case and cannot test.

- ETA

It is more convenient to use the software risk spectrum than to use Excel to perform event tree analysis.

1. Generate Analysis Result automatically

The software automatically generates initial event, function event, risk picture with possibility, consequence and sequence of function events.

2. The “GATE Event” Replaces “Basic Event” in Function Event

It is necessary to use Top Event or Gate Event of fault tree to replace the Basic Event in ETA. In DP2 system drive-off scenario, the probability of the function events is dynamic variable value, due to the real time availability of DP system and reliability of the DPO. A Basic Event with a permanent value of failure rate or probability cannot present the dynamic picture of real condition, but a Gate Event can present with the influence by the dynamic condition of the basic event. And Risk Spectrum Software can connect the function event with a fault tree. And the fault tree can also be used in other FTA or ETA. This function is important for the Online Risk Analysis.

Except many good points of this software, the user should pay attention to one point. Normally the function event assumes it as fail condition (Rausand, 2011). But the algorithm model in Risk Spectrum assumes that “Logical Event Success” as default (Scandpower, 2012) instead of “Logical Event Failure” as normal. And the possibility and failure rate have been input event by the predefined way in software automatically. The result is different from the normal calculation. Therefore, it is necessary to notice and choose “ignore ET success” setting in future modeling by the software

6.2 Comparison the risk pictures of different layouts and deploying Online Risk Decision Support System

As the Table 7 indicates, the probability from ST with ORDSS in oil offloading Layout 1 of Level A and Level B has been reduced dramatically, comparing with the probability of ST in Layout 1, Layout 2, and Layout 3. And the probability of layout 3 is acceptable, below 1E-04 level.

Table 8 Comparison among different layouts and arrangement

	Layout 1	Layout 2	Layout 3	Layout 1 with ORDSS
Level A	4.54E-04	3.30E-04	1.86E-05	1.08E-05
Level B	7.96E-05	1.43E-04	2.95E-05	5.33E-06

Level C	1.07E-04	1.67E-04	1.30E-04	5.24E-04
Level D	2.59E-04	2.59E-04	7.22E-04	3.60E-04
Collision	5.34E-04	4.73E-04	4.81E-05	1.61E-05
Near-miss	3.66E-04	4.27E-04	8.52E-04	8.84E-04

The reasons that the probability of collision reduction reduces tremendous are early predication and alarm detection, vessel maneuvering automatically and optimum maneuvering plan selected. It can save the operation time to increase the recovery window. In addition, it can reduce the serious degree of collision consequence, when the collision is unavoidable.

The probability of collision from Layout 2 has been reduction a certain amount, but the result is still at 1E-04 level. The result cannot be acceptable. In addition, this kind of offloading method should increase the length of the loading hose of the existing FPSO. It requires the FPSO running company to invest to modify the hose reel and the structure around. The cost for FPSO modification from design to construction and working time lost is beyond imagination. The cost effectiveness is not considered well.

The offloading method of layout 3 is the latest design and deployed by the column FPSO. Only few FPSOs in one or two fields are using or begin to use this layout. It is hardly to change the whole picture of the NCS. Furthermore, an even longer length of loading hose could be a certain amount of investment. And there is more length of loading hose floating among the roaring waves. It could increase the probability of oil hose rupture. Since it can also reduce the collision probability, it could also be a blueprint for the offloading operation in the future.

From the discussion above, the ORDSS is recommended to install ST as a cost efficient and convenient way to achieve the risk reduction.

6.3 The Validity of the ORDSS

The validity of ORDSS is quite important. The discussion on the validity is divided into three parts, the reliability of the data inputting and status prediction, the reliability

of the ORDSS, the reliability and timeliness of output including drive-off warning and alarm, time-remaining to collision, the effectiveness of risk of collision (probability of collision and collision effect), and countermeasure plan.

First, the data source input into the module is from three parts, reliable reliability handbook, history data in VDR, and sensor. The first two are trustable, since data is used as marine accident investigation and reliability handbook from manufacture or some institutes. As the introduction in chapter 5.3, the inaccurate predication rate of real-time failure rate is 20%. However, the status of drive-off presents as safe, high potential or drive-off activated instead of a serious number of probability, ex, $0.9E-01$. Therefore, after the process of fuzzyfication by Data Analysis model, the simple probability number is changed to a status as safe, high potential and drive-off. And the inaccuracy part is within the overlap area of two statuses, as the shadow area in Figure 35.



Figure 35 The inaccuracy predication area

The fail or fault alarm comes from the actual alarm from the Freeze Test, Prediction Test or out of presetting normal working limit. Therefore, the 20% inaccurate rate is only limited in warning scope. When a warning comes from the Situation Awareness System, the Decision Support and Simulation System does not take any action, and ORDSS does not bother the normal operation. One point should be noticed is that frequent incorrect warning could cause DPO some slack attention and lose the function of the pre-warning. However, this condition can be improved by history data mining and learning. The final accuracy could be within acceptable limit. Since software is based on computer system, the reliability of the software system, operation system, windows, and hardware. It is very hard to estimate the reliability of software system. But some data indicates the failure rate of a high reputation automation control system is around $3E-06$. Therefore, it could estimate the failure rate of

ORDSS is above $3E-06$ but less than $1E-05$, and it would not be much higher and is within an acceptable level.

The reliability and timeliness of drive-off alarm is the most critical information to send to DPO for situation awareness. Since the inaccurate rate of a single component prediction is 20%, the drive-off warning could be also affected. But the accurate rate of alarm is not affected. With condition complied with the MCS, the drive-off warning and alarm come immediately without any delay drive-off report. Nowadays, the drive-off alarm comes, when the speed is over a predefined value. Therefore, ORDSS has a better timeliness than the nowadays design. The reliability of time-remain to collision is one hundred percent, due to the accuracy of the formula used. However, this formula has been used in marine and offshore industry widely. It could be acceptable. In addition, with the wind sensor causing drive-off, the time estimation could be degraded, since the online time is not available, but the wind sensor readings to input into mathematical model is used by DP system. So the little deviation of the estimation remaining time to collision is acceptable. The effectiveness of risk of collision (probability of collision and collision effect), and countermeasure plan are based on the real time conditions of environment and available machineries and pre-evaluation plan including extreme low probability situation and all thrusters and rudder combination. It could be trustable. However, a simulation work to test these plans is also necessary to guarantee its full function.

Contingency plan shows the operation procedure to drive-off recovery. In ORDSS, it could integrate into Countermeasure Execution and Monitoring System, performing as an automation system. The step one and maneuvering operation procedure in step two can be suitable, since it is based on the real environment and equipment condition. But after the first two steps, due to changing status of environment and equipment, a pre-setting maneuvering operation procedure in step 4 may be not optimal. But the system itself or DPO could adjust the primary operation setting based on the design philosophy of step 4, since the DPO can adjust the ORDSS setting through HMI anytime during countermeasure plan execution. So ST can maneuver according to a

suitable plan but perhaps no optimal plan to escape from the offloading area safely.

6.4 Procedure to Select Position Reference Systems

Online

In chapter 3.1, the distribution pie present that there are 35% of drive-off cases due to the poor PRS selection. It is necessary to find a good PRS combination to be selected so as to reduce this fault happen. With same type of two PRS online, the total weight is more than others. When a common fault happens, the same type of two PRS fails or is signal drift or jump at same time. Then the Voting System makes an incorrect decision to select the fault PRS with higher weight as correct PRS and reject the right ones.

As the introduction in chapter 2.1.3, the DARPS and DGPS both deploy satellite to produce position data. The common faults cause the two system fault at same times. Therefore, the weight of the two systems should be summed up in the procedure to avoid incorrect decision from Voting System. The Artmis, HiPAP and Fanbeam are treated differently since there is only one of each without redundancy.

There are 14 types of PRS combination and the detail refers to Appendix VIII. The combination is according to the procedure that there should be at least one type of absolute PRS and two different types of relative PRS online. The combination of No.1, 2, and 3 have both high weight from DGPS and DARPS. The combination of No.4, 5, 6, 7, 8, and 9 have high weigh from DGPS or DARPS. The combination of No. 10, 11 and 12 have equal weight from each PRS, but they still have higher weight from DARPS and DGPS together. No. 13 and 14 have all equal weight with DARPS unselected. As the fault tree construction in Appendix II, the probability of the Gate Event “drive-off due to PRS is shown as the Appendix VIII. Therefore, it is recommended for the shuttle tanker in this paper to select these two PRS combinations. The best method to select PRS is one DGPS, and two of these three PRS, Artmis, Fanbeam, and HiPAP, online

After the analysis above, firstly it could recommend the DP software that can have the function to reduce the total weight of same type of the two or more PRS to the same weight as the single one PRS to reduce the probability of drive-off. Secondly, it is better for shipowner to select different type of system and manufacture of same type PRS installed onboard, due to the common fault. For example, GPS system could use different manufacture such as Fugro, Kongsberg, etc., or different satellite systems, such as Glonass from Russia, Gallieo from Europe, GPS from US and Beidou from China.

Chapter 7 Conclusion and future work

7.1 Conclusion

The paper presents a detail description of shuttle tanker DP 2 system about the relationship among position reference systems and sensors, functions of each system, and working principle. An applicable and representative structure model of DP2 shuttle tanker is developed to analysis the causes of drive-off.

A new method to classify drive-off case from IMCA Dynamic Position Station Keeping Incident Report from 1999 to 2006 by simple or multi causes has been introduced to replace the classification method only by simple reason. The classification result facilitates to construct the Fault tree of DP vessel drive-off. A new risk model of collision during tandem offloading operation is proposed to suit to ETA for drive-off of on different directions and different offloading layouts. Event Tree to evaluate the risk pictures of different tandem offloading layouts. After comparing the risk pictures, a vessel to install ORDSS is a most suitable method to reduce the probability of drive-off and collision. All the FTA and ETA are done by software, Risk Spectrum, and this software is not only suitable in nuclear industry but also can be used as analysis tool in offshore industry.

The structure of the ORDSS is built to present the relationship among each system. The models of different functions of ORDSS are established, including status prediction model for component and DP system, remaining time window for recovery, and probability and consequence of collision. The HMI can present the ORDSS analysis result, environment, and operation status clearly.

In addition, a PRS selection procedure and Contingency Plan for drive-off are proposed. All PRS selection plan have been analysis by the fault tree, and the one with lowest value to cause drive-off is selected. And the contingency plan, which all thruster and rudder are at available condition, has been tested on the simulator at SMSC and it can improve the successful recover and reduce the tension and nervous

of the operator.

Furthermore, a PRS selection method to reduce the probability of drive-off is proposed. The best method to select PRS is one DGPS, and two of these three PRS, Artmis, Fanbeam, and HiPAP, online. In addition two recommendations to improve DP system to reduce probability of drive-off is mentioned.

7.2 Future work

There are two levels for the future work. Level one is history data updating and model testing, and level two is to develop a software program.

Level One:

1. The fault tree and data analysis model are both built on the history data. The fault tree in this paper is based on the technical analysis of DP system and IMCA Station Keeping Incident Report from 1999 to 2006. The drive-off accident case from 2007 to 2015 should be input into history database to update and test the fault tree, whether all causes of drive-off are included. In addition, the Data Analysis Model is to predict the failure rate or status of component on the data of this component and other relative factors.
2. All the countermeasures or the contingency test plan at different environment condition should be tested on ship maneuvering simulation program, for example ShipX or shuttle tanker simulator to find the deficiency. Until now, only the contingency plan for shuttle tanker drive-off caused by 100% engine power forward at no wind and current condition and full availability of rudder, bow and aft thruster is tested, and the result is success. But the availability of other cases is also necessary to confirm.
3. The model of human errors combined with technical system faults is clearly presented in fault tree. The detection of human error due to simple human error is based on the result of simulation to the information input into the DP system, but this simulation model and the method to construct this mode are not presented.

The human errors are not considered enough. The DP operation becomes more comprehensive and certification issuing become stricter, especially on shuttle tanker operation, and the human error is more reduced. However, it still exists. In addition, the mode to reduce the human failure rate in countermeasure execution stage should also be proposed and tested.

Level Two:

The ORDSS is based on software program as description. A software program operating under Windows, PLC, or Single Chip Processor should be developed to realize the function of drive-off detection, decision support and simulation, decision execution and monitoring with HMI. And the function and reliability should be tested with the simulators.

Reference

- [1] Jan-Erik Vinnem, Ingrid B. Utne. 2015. Risk Reduction for Floating Offshore Installations through Barrier Management
- [2] Magne Erik K. Lundborg. 2014. Human Technical Factors in FPSO Shuttle Tanker Interactions and Their Influence on the Collision Risk during Operations in the North Sea.
- [3] Jan Erik Vinnem. 2015. On the Need for Online Decision Support in FPSO–Shuttle Tanker Collision Risk Reduction.
- [4] IMCA 1999. Guidelines for the Design and Operation of Dynamically Positioned Vessels. IMCA M 103.
- [5] IMO.1994. Guidelines for Vessels with Dynamic Position System. MSC circ 645
- [6] Haibo Chen, T. Moan. 2005. DP incidents on mobile offshore drilling units on the Norwegian Continental Shelf.
- [7] A.D. Swain, H. E. Guttman, 1983, Handbook of Human Reliability Analysis with Emphasis on Nuclear Power Plant Applications
- [8] Yuhan. Jiang, 2014, Offshore QRA: Assessing Safety during DP Operations
- [9] Sintef, 2014, Offshore QRA: Assessing Safety during DP Operations
- [10] SMSC. Course compendium of Offshore loading phase 2. Ship Maneuvering Simulator Centre AS, Trondheim, 2000.
- [11] NTS. Design of Steel Structures – Annex L Special Design

Provisions for Ship Shaped Units. NORSOK Standard N-004, Rev. 1, 1998.

[12] Asbjørnslett, Bjørn Egil, 2015, Compendium for risk analysis for maritime transportaion

[13] Blue water, 2013,

<http://www.bluewater.com/wp-content/uploads/2013/03/3.2.1-spread-moo-ring-blo-omiaft.jpg>

[14] Kongsberg, 2014, MRU D technical specification

[http://www.km.kongsberg.com/ks/web/nokbg0397.nsf/AllWeb/BB1EFDCC1EE3EEEDC1257B8200481856/\\$file/Datasheet_mruD_march14.pdf?](http://www.km.kongsberg.com/ks/web/nokbg0397.nsf/AllWeb/BB1EFDCC1EE3EEEDC1257B8200481856/$file/Datasheet_mruD_march14.pdf?OpenElement)

OpenElement

[15] Kongsberg, 2015, Joystick control system

<http://www.km.kongsberg.com/ks/web/nokbg0240.nsf/AllWeb/C03BD1E52C6E8B02C1256A4900282075?OpenDocument>

[16] Scandpower AB, 2012, Risk Spectrum Tools Theory Manual, Version 3.1.2

[17] IMCA 1999, Dynamic Position Station Keeping Incident reported for 1999

[17] IMCA 2000, Dynamic Position Station Keeping Incident reported for 1999

[18] IMCA 2001, Dynamic Position Station Keeping Incident reported for 2000

[19] IMCA 2003, Dynamic Position Station Keeping Incident reported for 2001

[20] IMCA 2004, Dynamic Position Station Keeping Incident reported for 2002

[21] IMCA 2005, Dynamic Position Station Keeping Incident reported for 2003

[22] IMCA 2006, Dynamic Position Station Keeping Incident reported for 2004

[23] IMCA 2007, Dynamic Position Station Keeping Incident reported for 2005

[24] IMCA 2008, Dynamic Position Station Keeping Incident reported for 2006

[25] IMCA 2012, Dynamic Position Station Keeping Incident reported for 2010

[26] Haibo Chen, 2004. Probabilistic Evaluation of FPSO - Tanker Collision in Tandem Offloading Operation.

[27] Marvin Rausand, 2004. System Reliability Theory Models, Statistical Methods, and Application

[28] Haibo Chen, Torgeir Moan, Harry Verhoeven, 2009. Effect of DGPS failures on dynamic positioning of mobile drilling units in the North Sea

[28] Meng Tang, 2004. The Adaptive Intelligent Model for Process Diagnosis, Prediction and Control

- [29] Haibo Chen, 2005. DP Operation Reaction Time in Drive-off Scenarios – Update based on Simulator Data in 2005
- [30] Sverre Steen, 2015, Compendium for Naval Hydrodynamics
- [31] SMSC. Course compendium of DP Introduction. Ship Maneuvering Simulator Centre AS, Trondheim, 2000. [Restricted]
- [32] Arntzen Lars, 2016, Personal communication with Mr. Arntzen, DP Instructor at SMSC
- [33] Edvardsen Jan-Inge, 2016, Personal communication with Mr. Edvardsen, DP Instructor at SMSC
- [34] Tone Janeth Skare Martinsen, 2013. Characteristics of critical Incident in Dynamic Positioning
- [35] Jan Erik Vinnem. 2013. Offshore Risk Assessment Principles, Modeling and Applications of QRA Studies. Third Edition.
- [36] IMCA, 1999. Guidelines for the Design and Operation of Dynamically Positioned Vessels
- [13] GeNIe, 2015. https://dslpitt.org/genie/wiki/GeNIe_Documentation

Appendix I

IMCA DP Station Keeping Incident Data

No.	Date	IMCA NO.	Description	Reason 1	Reason 2	Reason 3
01	1999	9904	CPP zero Pitch	Propulsion		
02	1999	9907	Thruster fault	Propulsion		
03	1999	9910	HPR/ position jump	PRS	Control system	
04	1999	9911	software error	Control System	Human Error	
05	1999	9923		Propulsion	Human Error	
06	1999	9924	DGPS lost	PRS	Control system	Poor Procedure
07	2000	0025	DGPS jump	PRS	Control system	Poor Procedure
08	2000	0026	Artmis	PRS	Control system	Poor Procedure
09	2000	0031	two DGPS variance /HPR as original	PRS	Control system	Poor Procedure
10	2000	0033	Pitch	Propulsion		
11	2000	0034	Pitch	Propulsion		
12	2000	0038	Noise rejection level for acoustics wrongly set	PRS	Human Error	Poor Procedure
13	2000	0039	HPR/ and DPC give too much weight on HPR	PRS	Control system	Poor Procedure
14	2000	0048	Better software was needed or small step changes by operator	Operator error	Insufficient test	

15	2000	0049	the ploug becoming stuck while the DP wants to catch up to keep constant speed average	Operator error	Environment	
16	2000	0050	The software had been modified to absorb the artemis offset position but the operator was unaware	Operator error		
17	2000	0054	Artmis	PRS	Control system	Poor Procedure
18	2000	0055	Different distance between DARPS and Artmis	PRS	Control system	Poor Procedure
19	2000	0062	DGPS degrade	PRS	Poor Procedure	
20	2000	0065	Gyro fail and affect other PRS	PRS		
21	2001	0101	DP software	Control System	Insufficient test	
22	2001	0102	DP software	Control System	Insufficient test	
23	2001	0103	DP software	Control System	Insufficient test	
24	2001	0104	Prediction error by software	Control System	Operator	
25	2001	0110	Wind gust 50knot ahead/ wind sensor 88 knot	Wind Sensor		
26	2001	0111	severl thruster fail at on environment and all power output by other thruster and drive-off	Propulsion	Control system	
27	2001	0115	Operator only select 2 pcs DARPS online only	PRS	Poor Procedure	Human Error
28	2001	0118	UHF interference on the DARPS	PRS	Control system	Poor Procedure
29	2001	0119	Vessel off position + No.4 deselected and No.2 high thrust output warning	Propulsion	Control system	

30	2001	0123	software bug	Control System	Insufficient test	
31	2001	0124	software bug	Control System		
32	2001	0125	Prediction error by software	Control System		
33	2001	0127	software bug	Control System	Insufficient test	
34	2001	0128	software bug	Control System	Insufficient test	
35	2001	0129	software bug	Control System	Insufficient test	
36	2001	0136	wind sensor give a much more wind speed o DPC. Spurious signal	Wind Sensor		
37	2001	0143	input wrong	Operator error		
38	2001	0144	DGPS and HPR online	PRS	Poor Procedure	Operator
39	2001	0146	DGPS	PRS	Control system	Poor Procedure
40	2001	0148	DARPS show wrong distance and FPSO heading	PRS	Control system	Poor Procedure
41	2001	0150	pitch control	Propulsion		
42	2001	0152	Pitch	Propulsion		
43	2002	0205	DARPS only in use	PRS	Poor Procedure	
44	2002	0210	Operator deselect one control	Operator error		
45	2002	0212	Pitch stuck	Propulsion		
46	2002	0217	thruster set point and feedback due to a fault in a controller card	Propulsion		
47	2002	0218	short for experience	Operator error		

49	2002	0221	the DP operator did not understand the DGPS warning, and lack of implications; the replumbing of HPR was mistake	PRS	Human Error	
50	2002	0222	the operator did not aware of the set point/ feedback warning	Thruster control	Operator	
51	2002	0223	2 DGPS onlie/ 1 HPR standby	PRS	Control system	Poor Procedure
52	2003	0302	Aft Position Alarm	Thruster control		
53	2003	0305	PRS rejected	PRS	Operator error	Poor Procedure
54	2003	0310		Propulsion	Insufficient test	
55	2003	0312		Propulsion	Insufficient test	
56	2003	0313	Both DGPSs frozen at same time	PRS	Control system	Human Error
57	2003	0314	Both DGPS fault at same time	PRS	Control system	Human Error
58	2003	0318	Chain in tension	Thruster control		
59	2003	0320	Software accept wrong signal	Control System		
60	2003	0323	DGPS	PRS	Poor Procedure	Control system
61	2003	0324	DGPS(Number of DGPS is not mentioned)	Gyro	PRS	Poor Procedure
62	2003	0328	Software fault	Control System		
63	2003	0336	Lighting storm	Wind Sensor	Environment	
64	2003	0337	both DGPS error	PRS	Control system	Human Error
65	2003	0339	Fanbeam locks on reflect jacket	PRS	Control system	Human Error
66	2003	0340	Thruster control spurious output, and main engine no reply	Thruster Control		

67	2003	0341	Thruster control spurious output, and main engine no reply	Thruster Control		
68	2003	0342	Both DGPS fault at same time	PRS	Control system	Poor Procedure
69	2004	0404	DPO set the DP with high gain but not recovery to the normal DP mode after first time collision avoidance. The accident cause by a change in the current	Operator error		
70	2004	0408	use of the quick current update is not suitable for making allowances for heading changes when external pipeline forces are being experienced	Operator error	Poor Procedure	
71	2004	0411	software setting	Control System		
72	2004	0412	astern thrust at 50% and hawser in tension. The fault thruster deselect, and the DP system started to compensate the remaining CPP output a high force to balance the tension in hawser	Thruster control		
73	2004	0413	FPSO surge motion at 1 knot due to Acoustics	PRS	Poor Procedure	Human Error
74	2004	0420	DGPS fault due to the satellite problem	PRS	Poor Procedure	
75	2004	0421	DGPS fault	PRS	Control system	Poor Procedure
76	2005	0504	Pitch pump fail	Propulsion		
77	2005	0510	2 DGPS online	PRS	Poor Procedure	
78	2005	0514	2 DGPS& 1 HiPAP	PRS	Control system	Poor Procedure
79	2005	0518	Fishing Vessel	Operator error		

80	2005	0519	Pitch stuck	Propulsion		
81	2005	0521	Pitch stuck	Propulsion		
82	2006	0602	Human error, engineer moving thruster to full pitch without notifying the bridge	Operator error	Poor Procedure	
83	2006	0608	Intermittent DGPS signal	PRS	Control system	Poor Procedure
84	2006	0609	Intermittent DGPS signal	PRS	Control system	Poor Procedure
85	2006	0613	spurious reading of 60 knot	Wind Sensor		
86	2006	0616	total loss DGPS	PRS	Environment	
88	2006	0621	wind sensor give a much more wind speed o DPC. Spurious signal	Wind Sensor		
89	2006	0629	DARPS affect gyro	PRS	Gyro	
90	2006	0630	human error, insufficient knowledge of tandem loading software	Control System	Operator	

Note: Since the Taut Wire is not used on the DP vessel operating at North Sea, the position loss caused by Taut Wire is not considered.

Collision Scenario Analysis

Ship Index	Mode	Experience	Thruster Output Abnormal Detection	Limited Distance to FPSO	Manual Takeover	Astern Thruster Initiated	Rotation Initiated	Result	Note
01	loading	Yes	Yes but not in time (human factor)	/	Yes	Yes	NO	Collision	thruster abnormal detected after 50 s
02	approaching	Yes	Yes	/	Yes	Yes	Yes	Near-miss	Ulstein has recently installed a device

									bringing the main propeller to zero in case of any failure
03	Loading	Yes	In manual condition	failure to alarm in Manual mode	Yes	Yes	yes	Collision	
04	loading	No	No	/	Yes	Yes	No	Collision	Reselect the wrong sensor information
05	loading	No	Yes	Yes	Yes	Yes	NO	Collision	

Appendix II

Fault Tree Analysis for Shuttle Tanker Drive-off

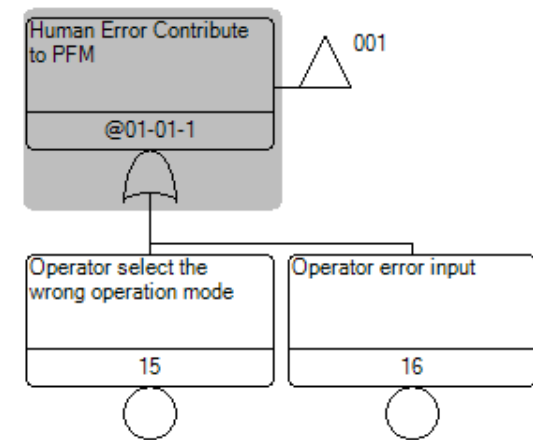
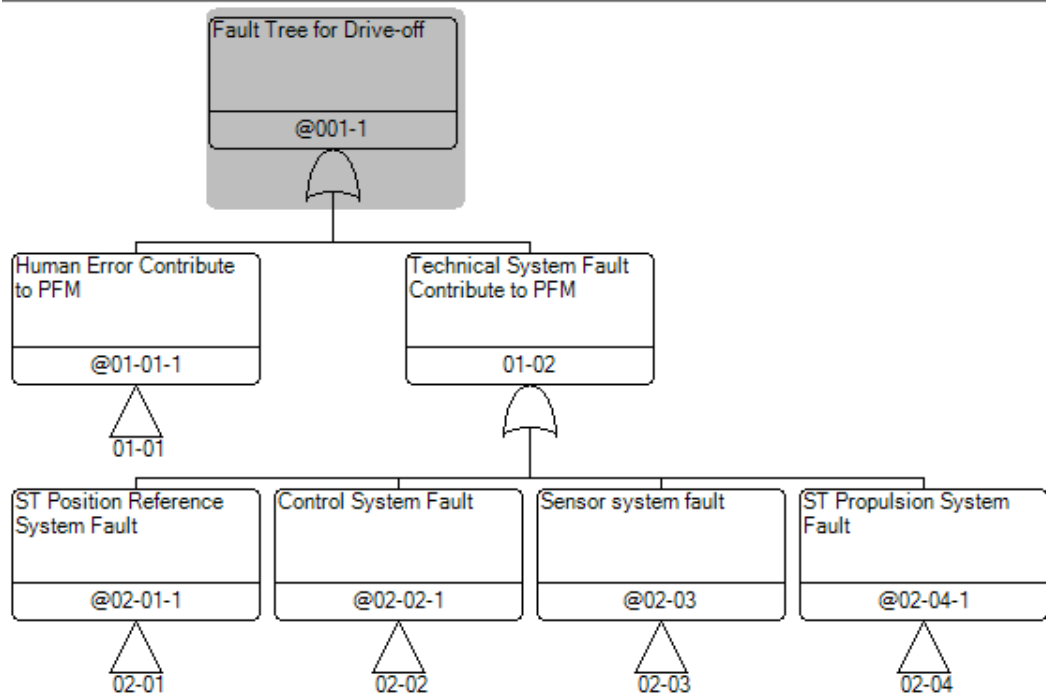

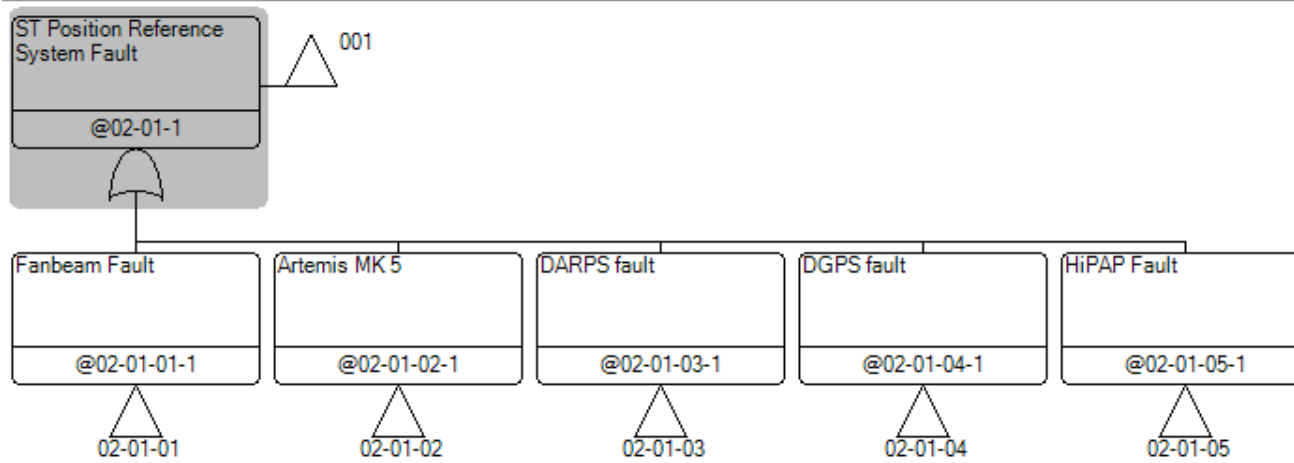

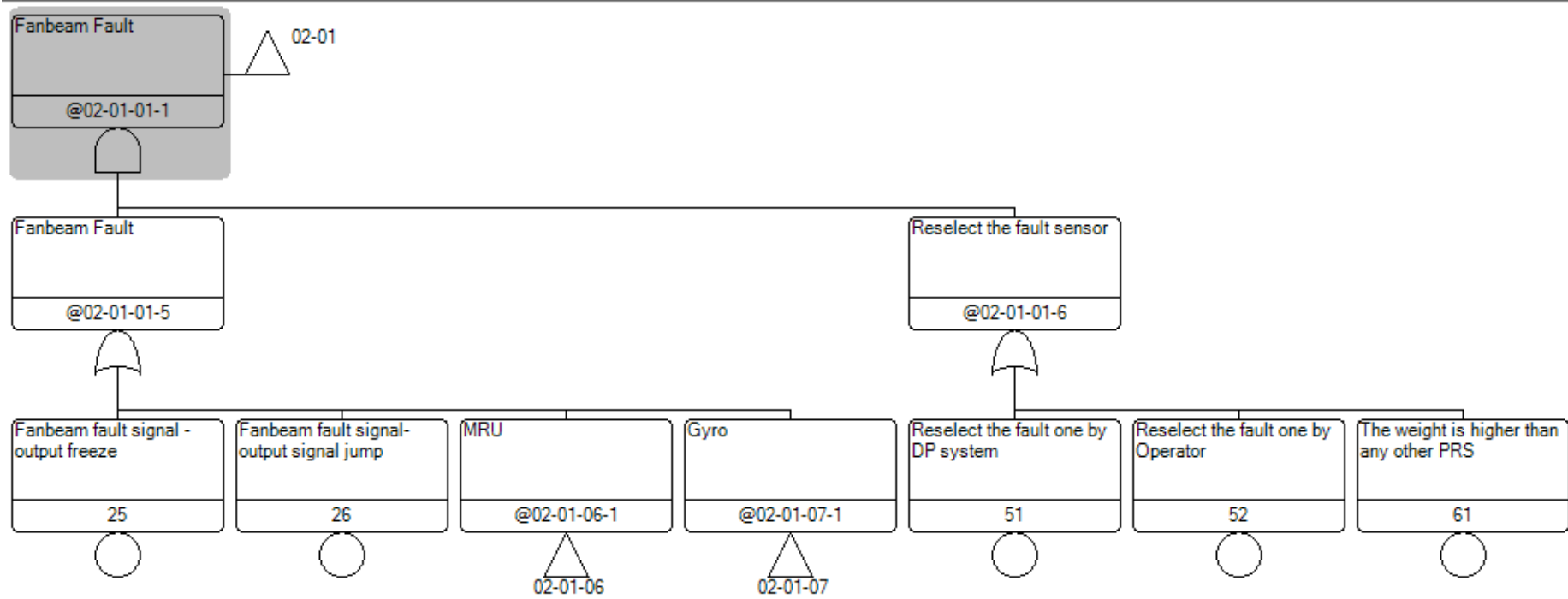

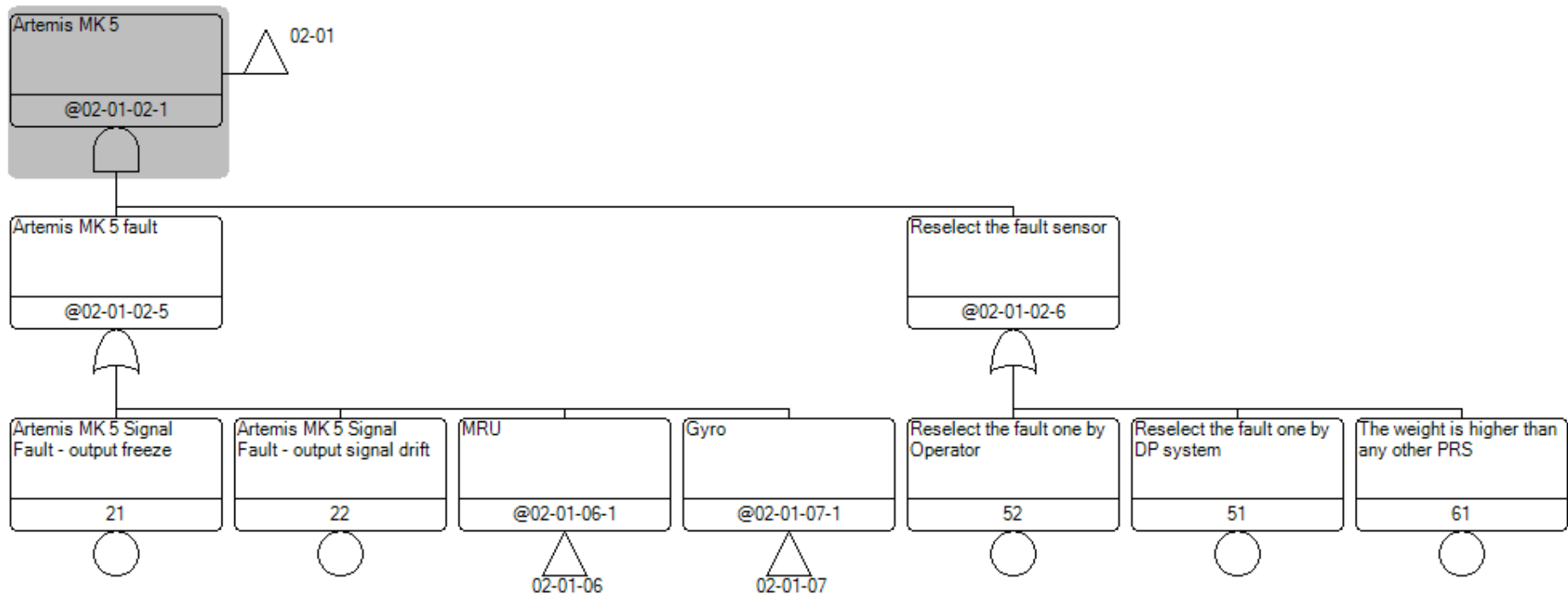

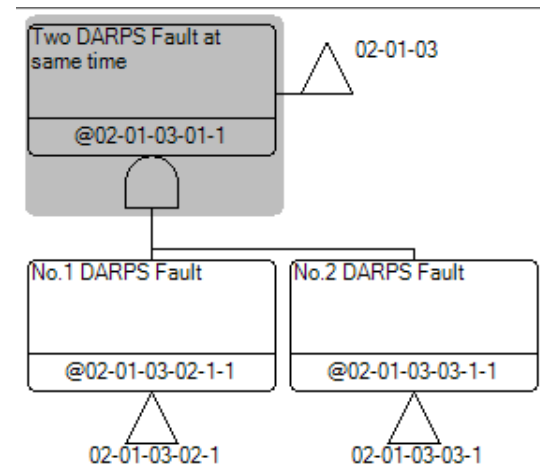

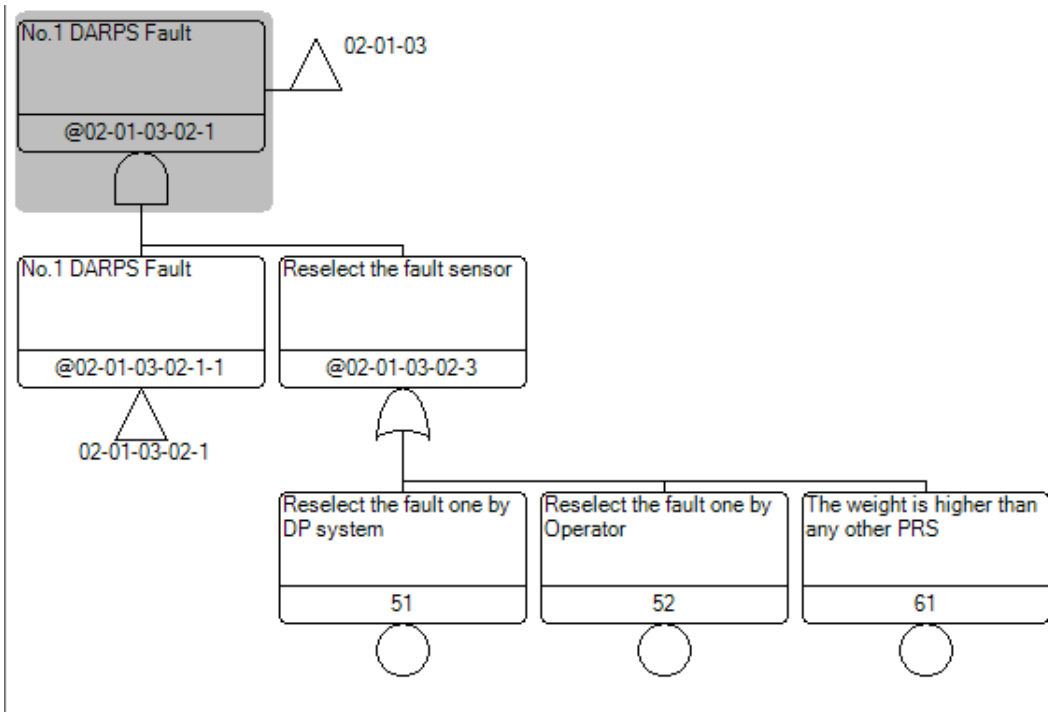

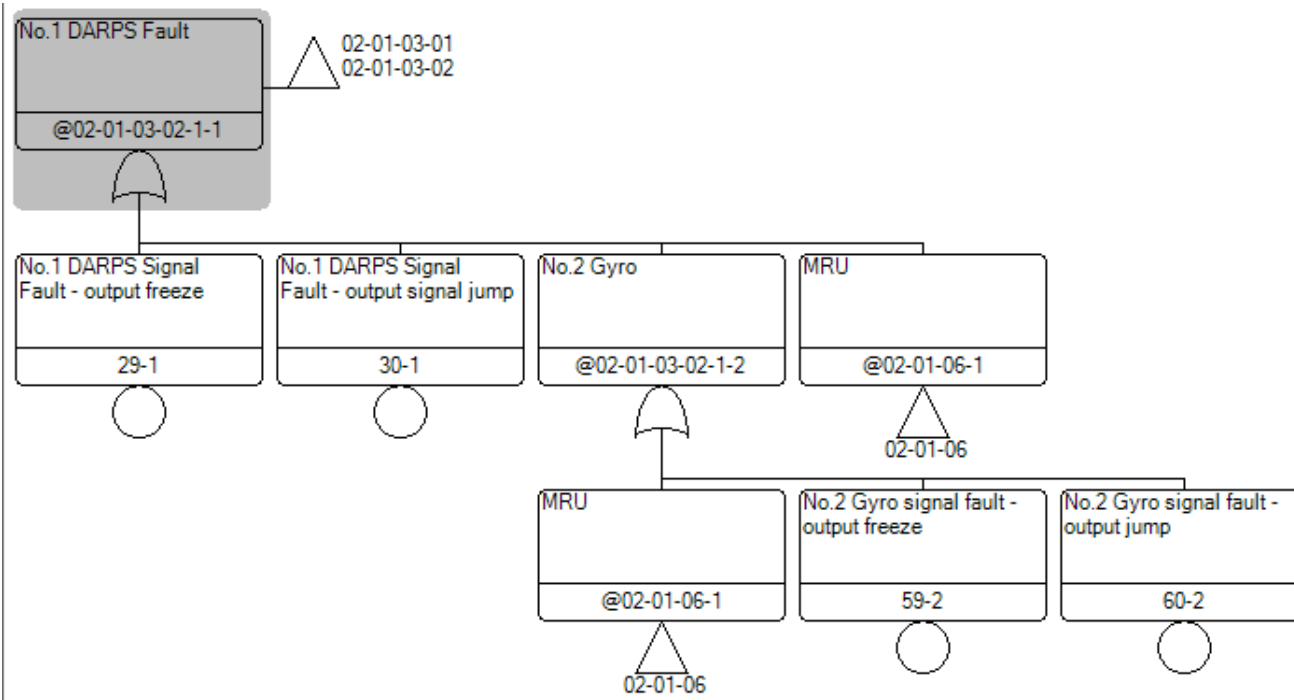

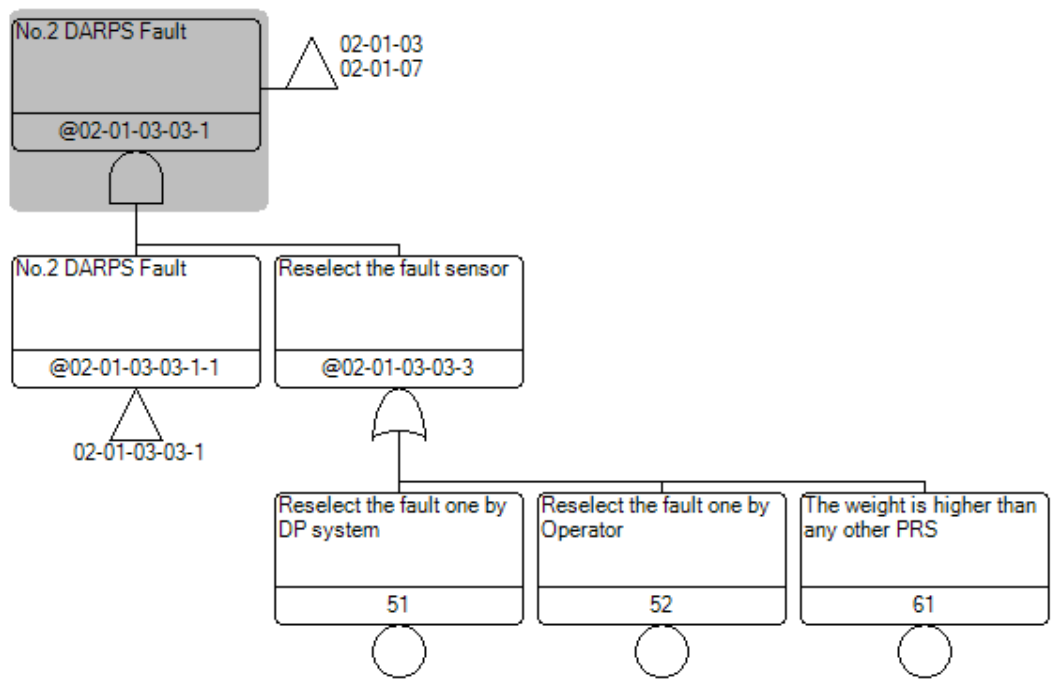

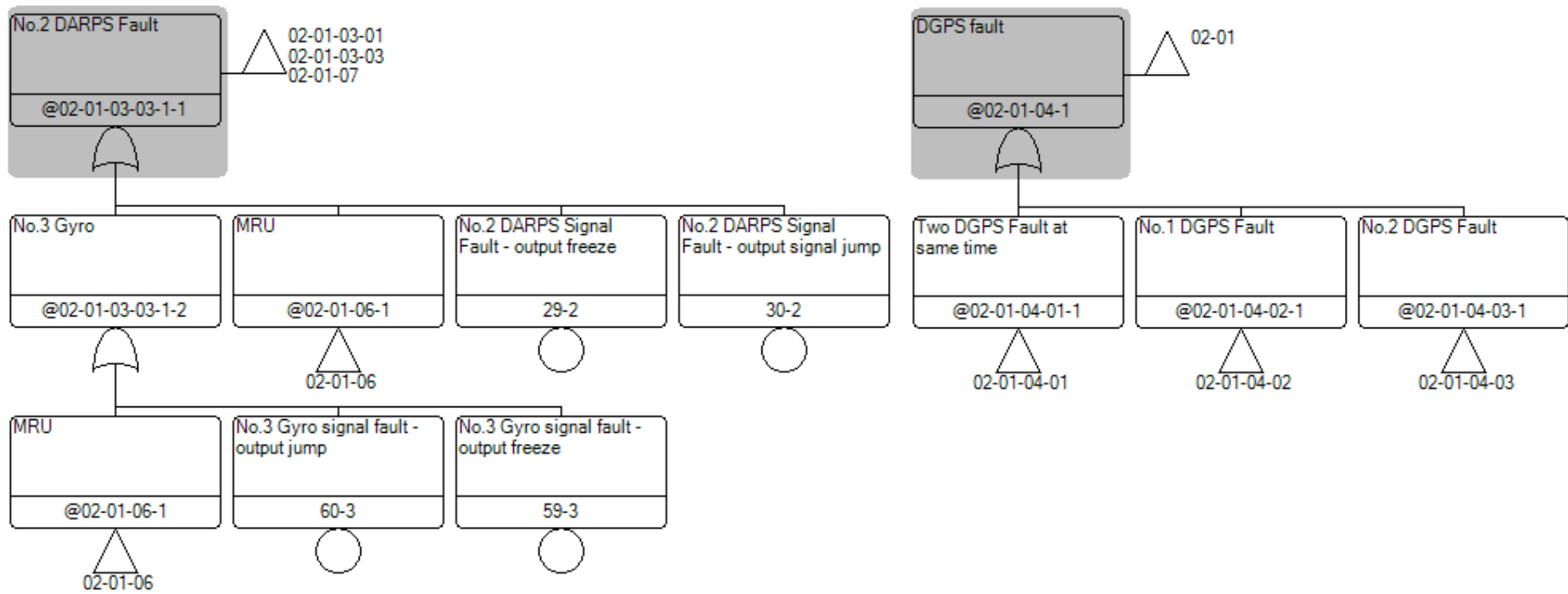

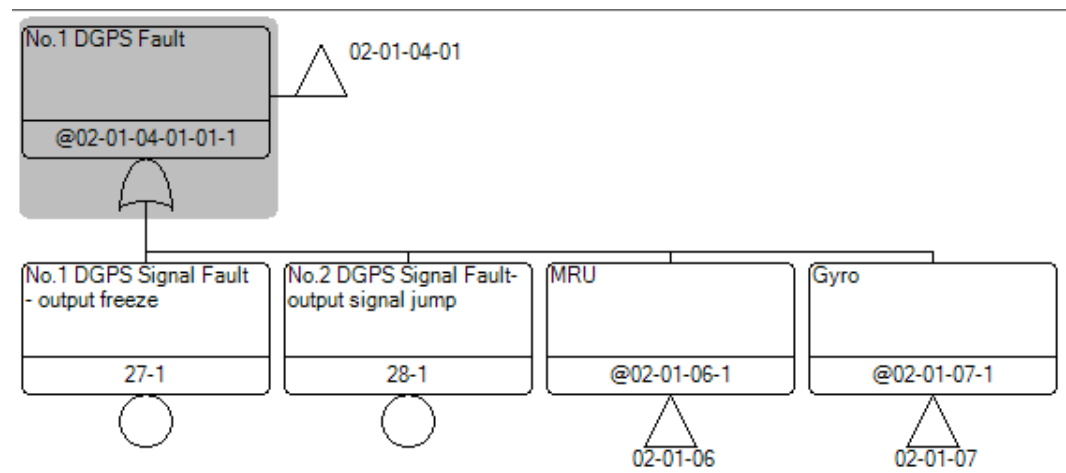
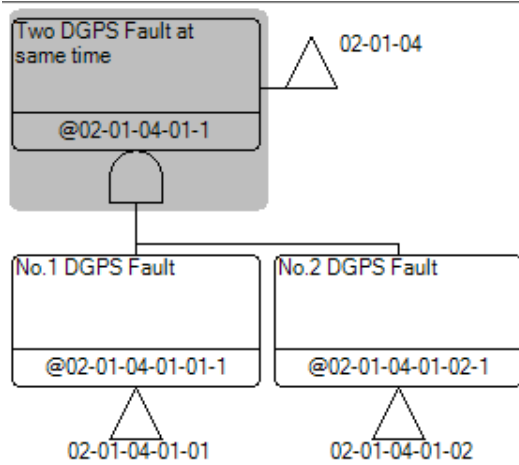

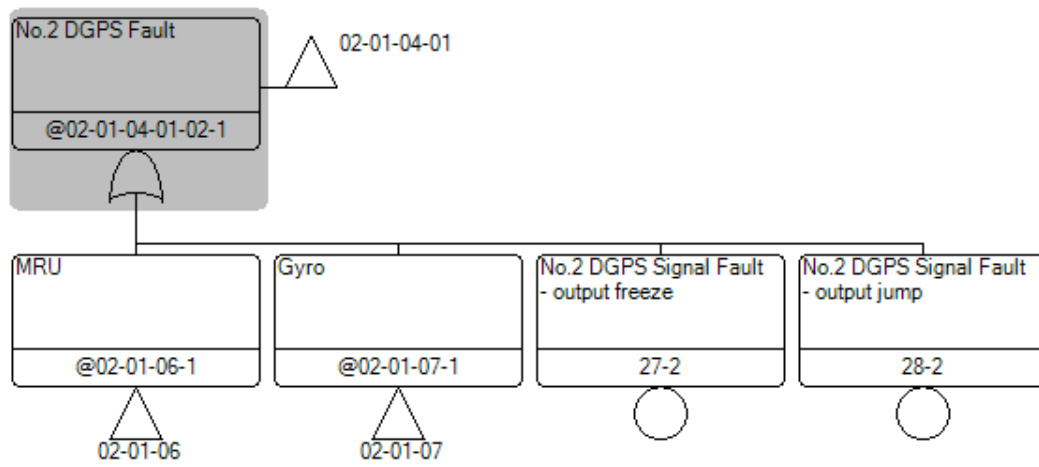

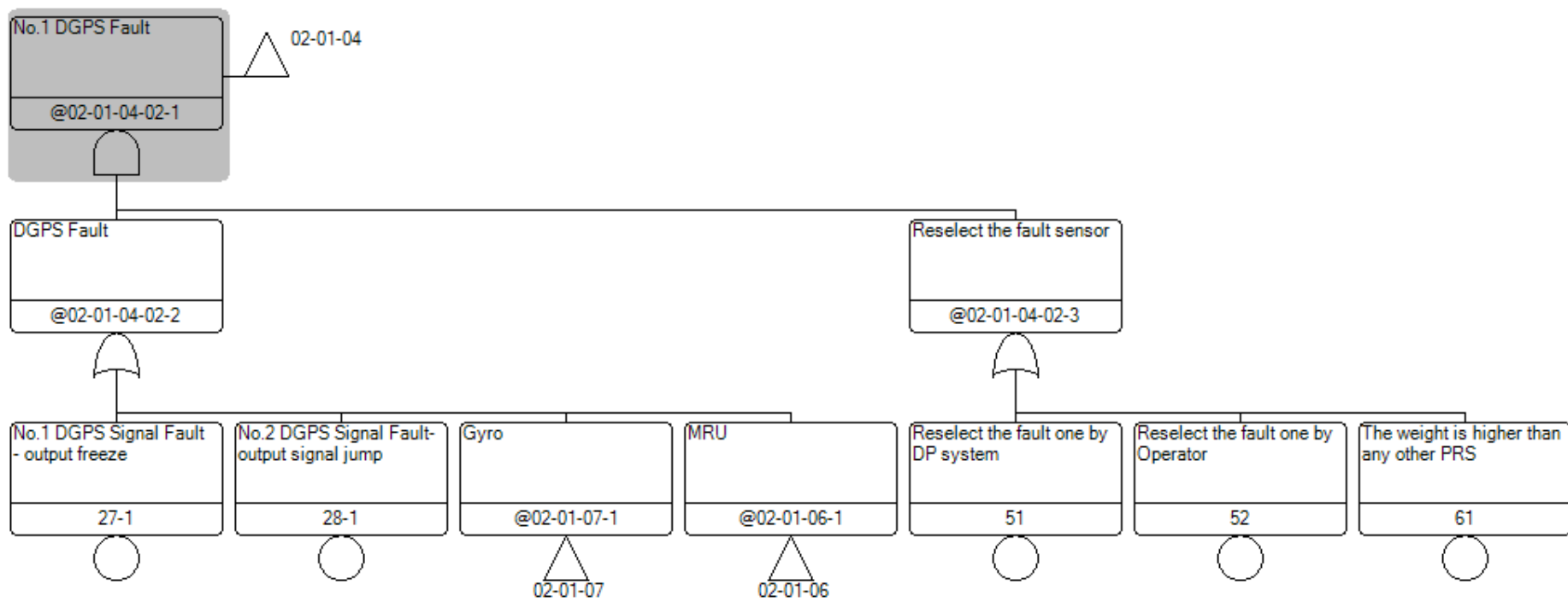

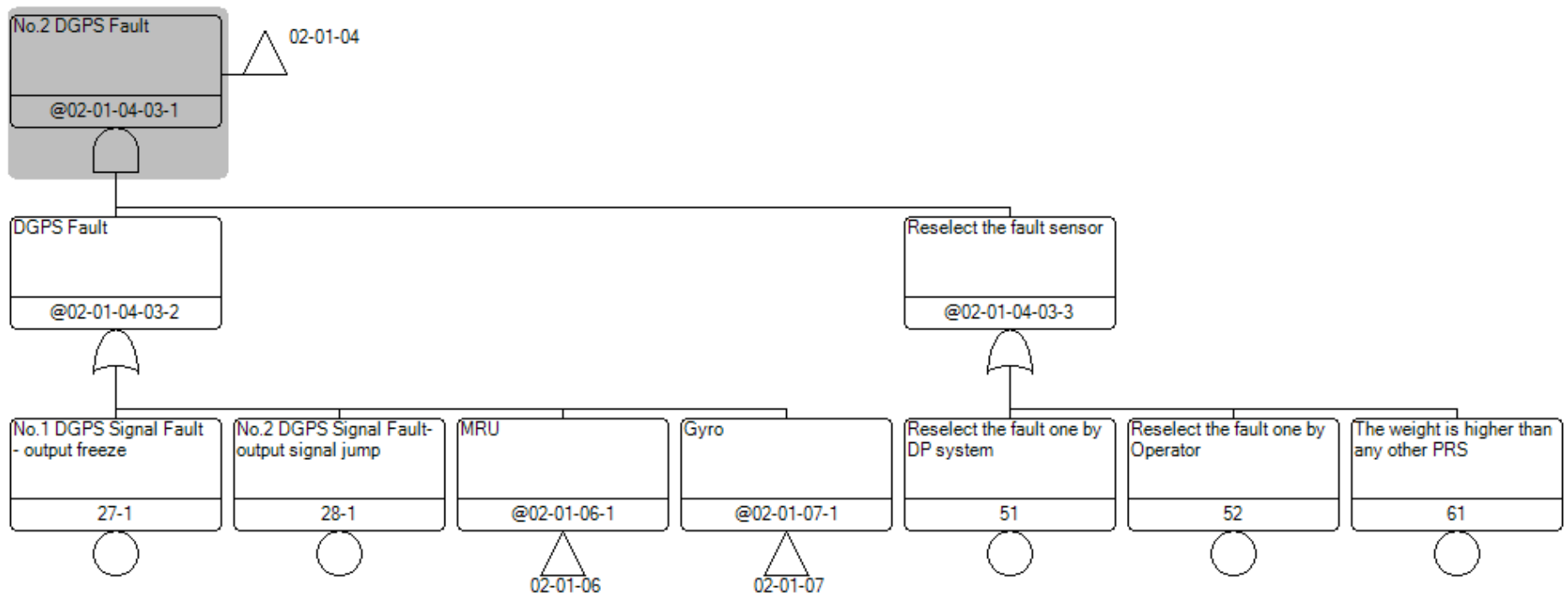

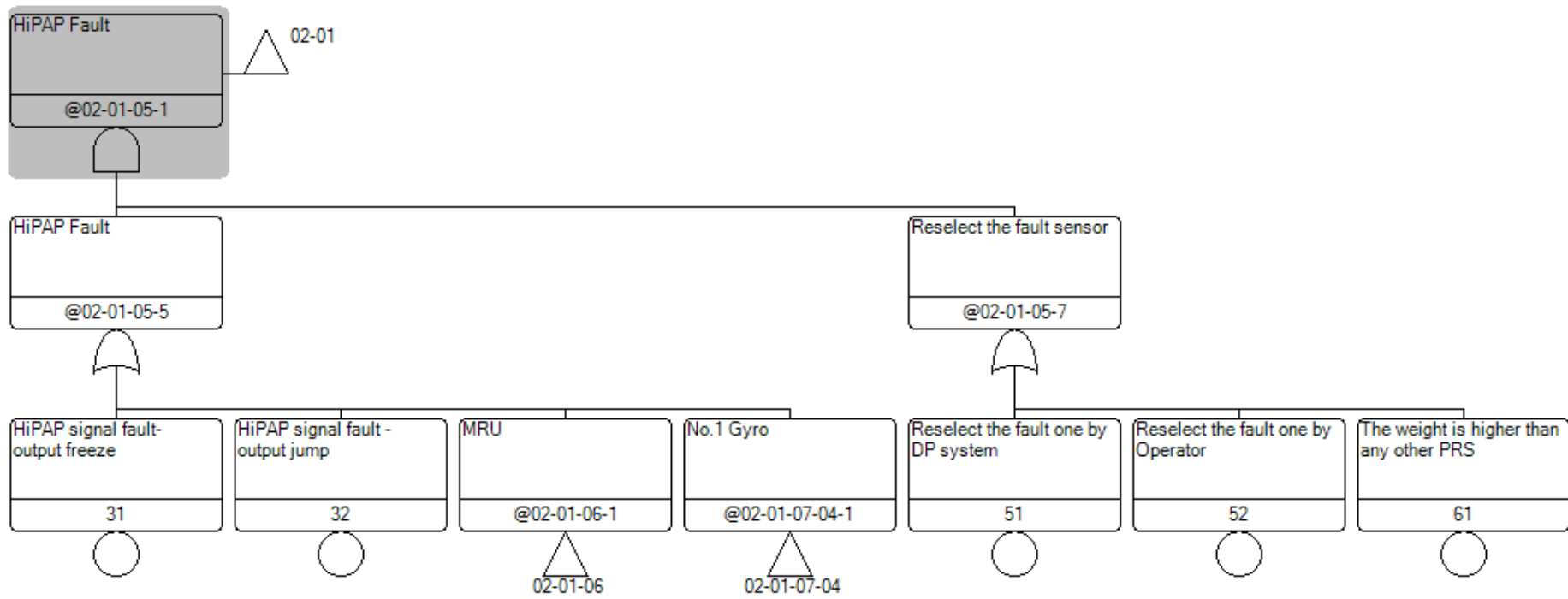

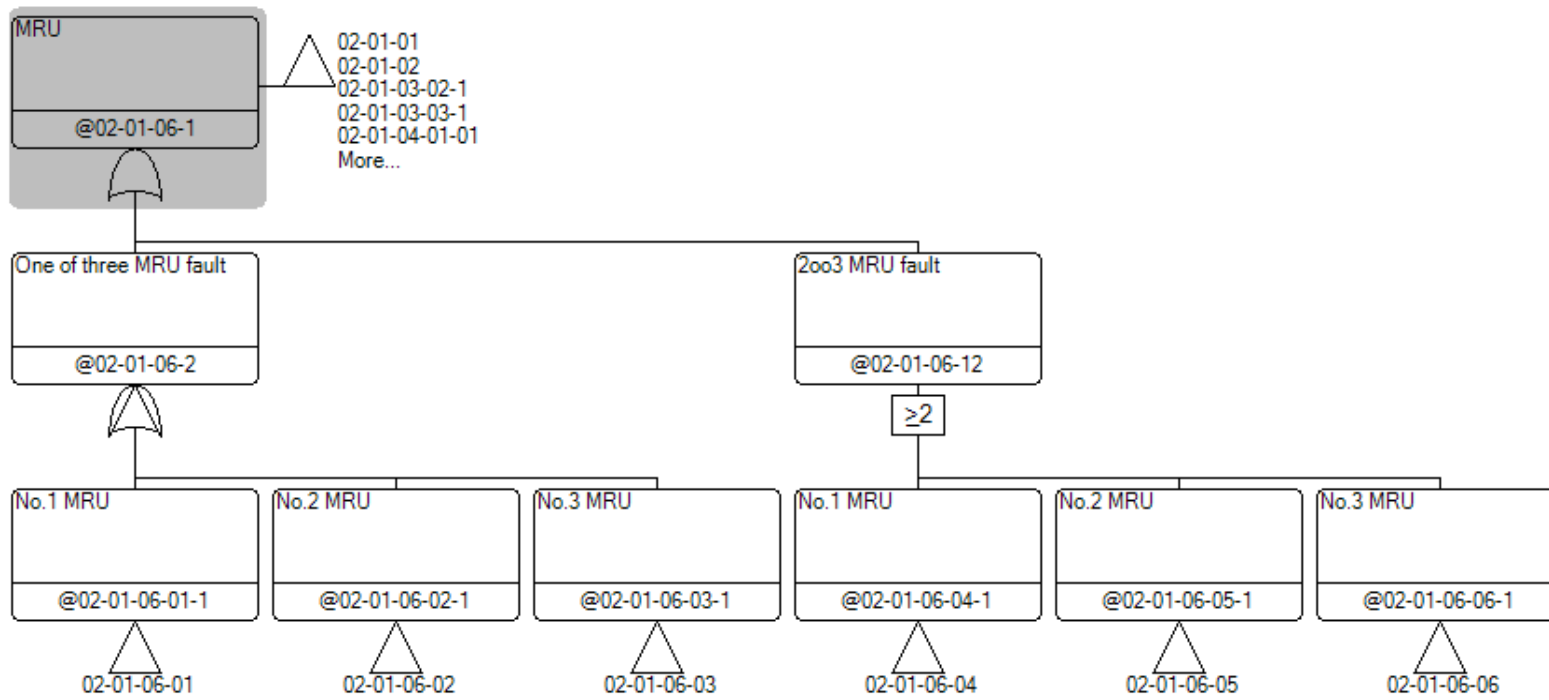

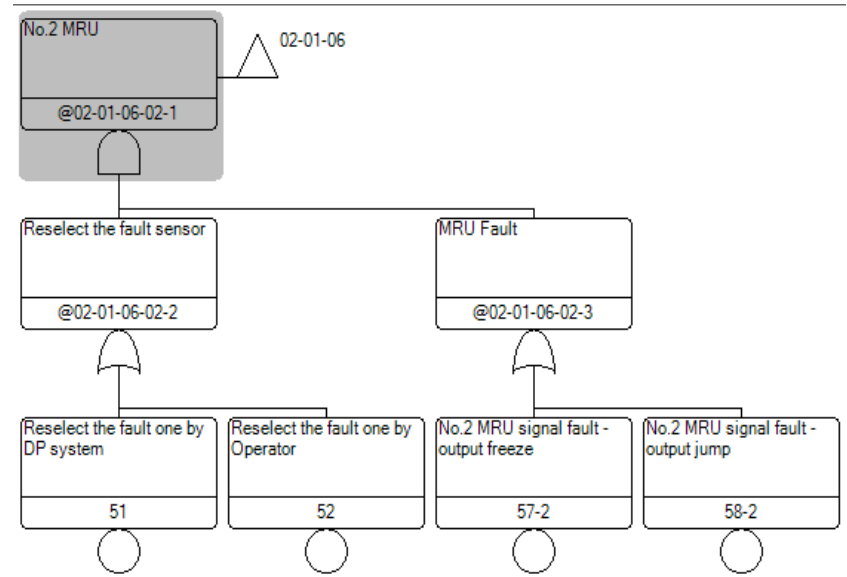
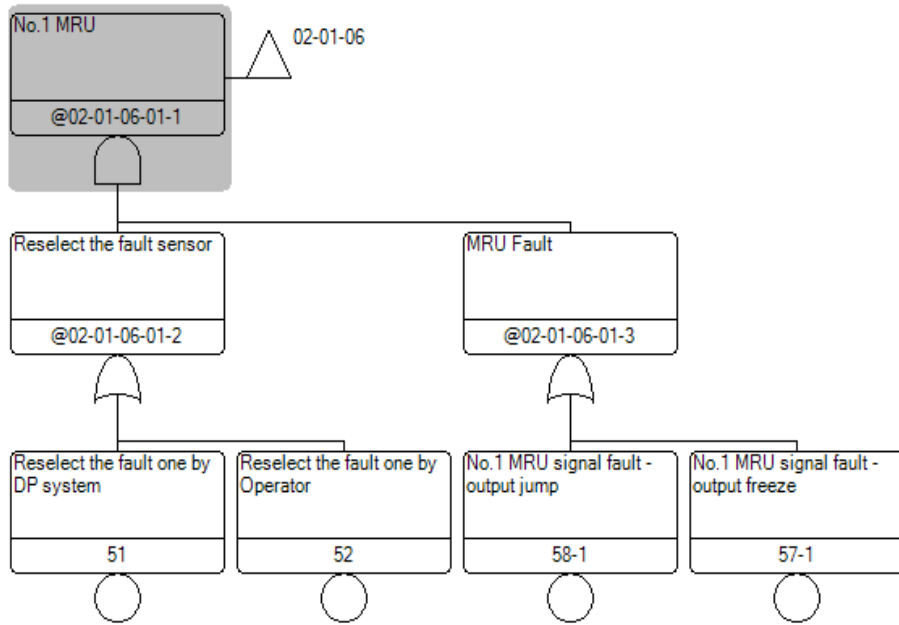

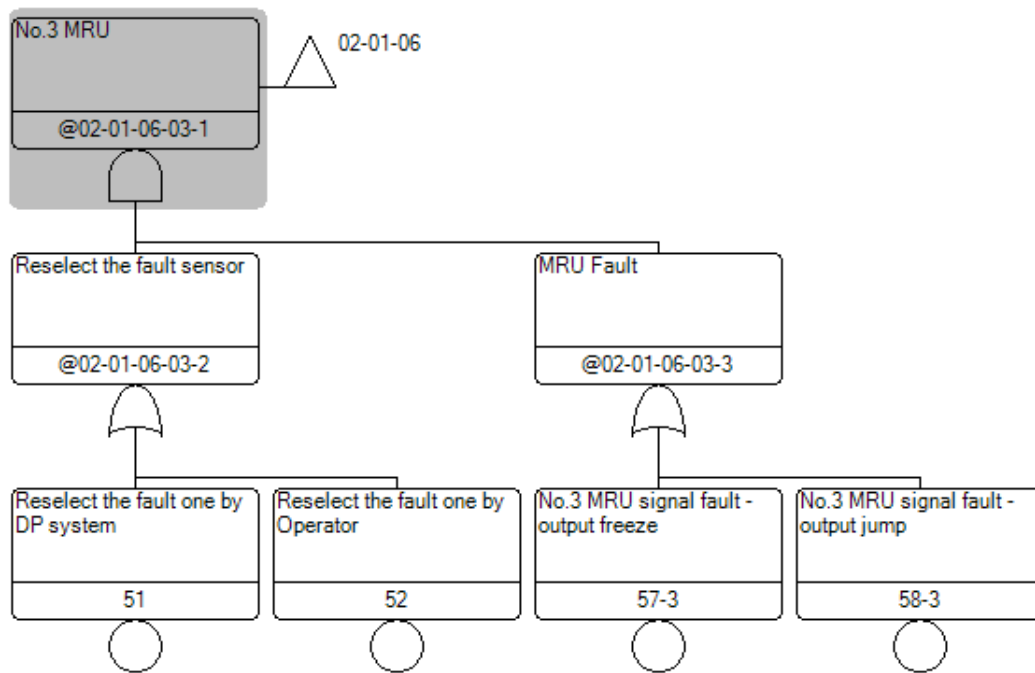

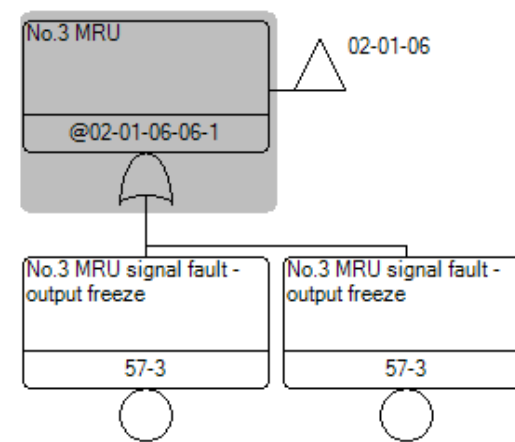
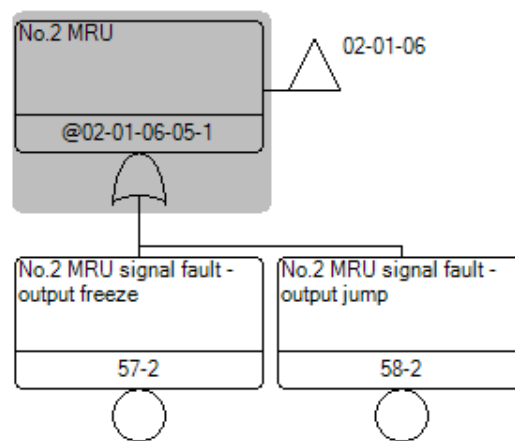
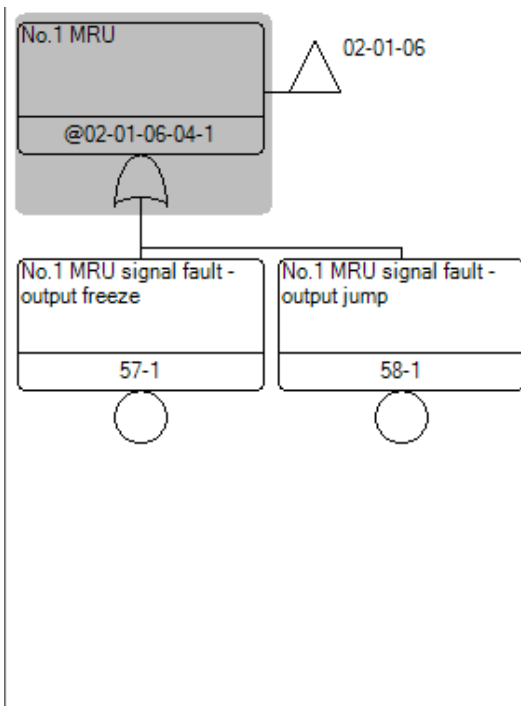

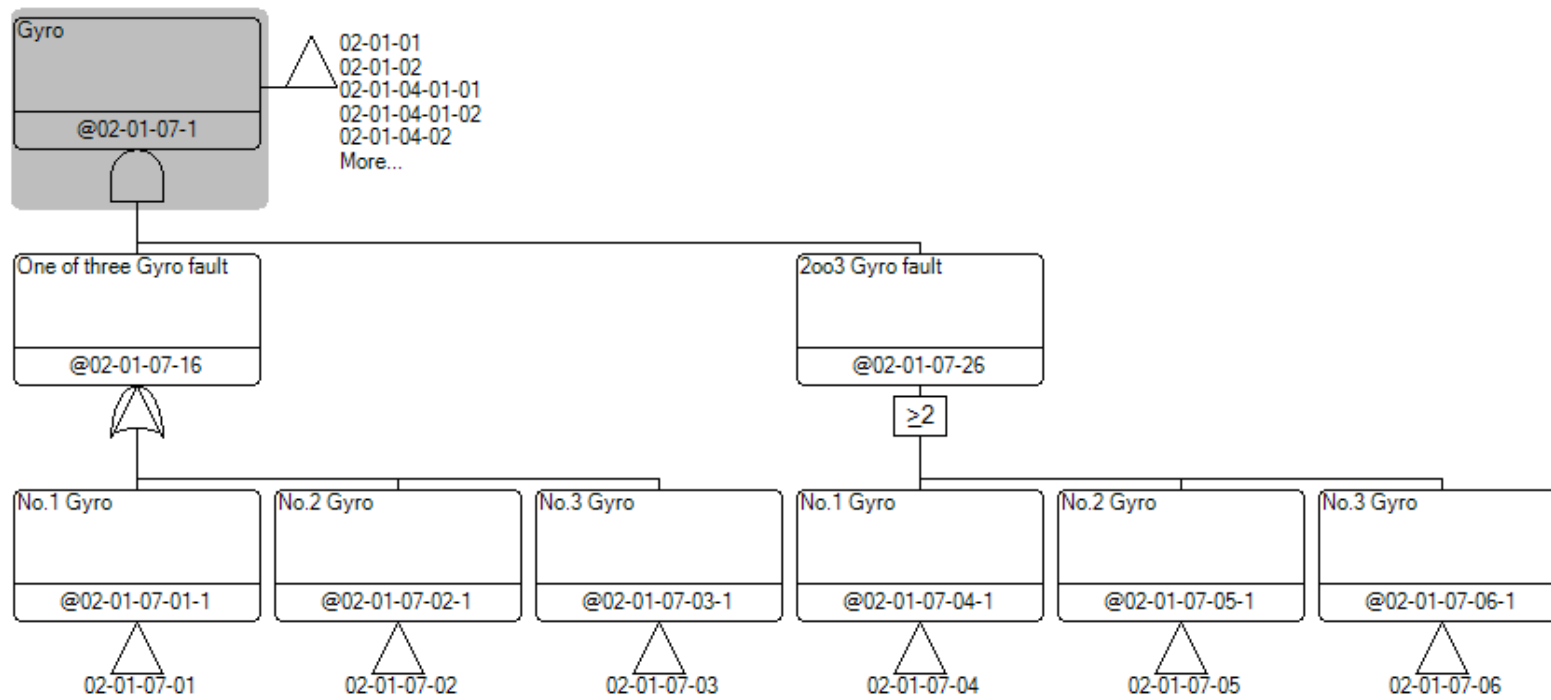

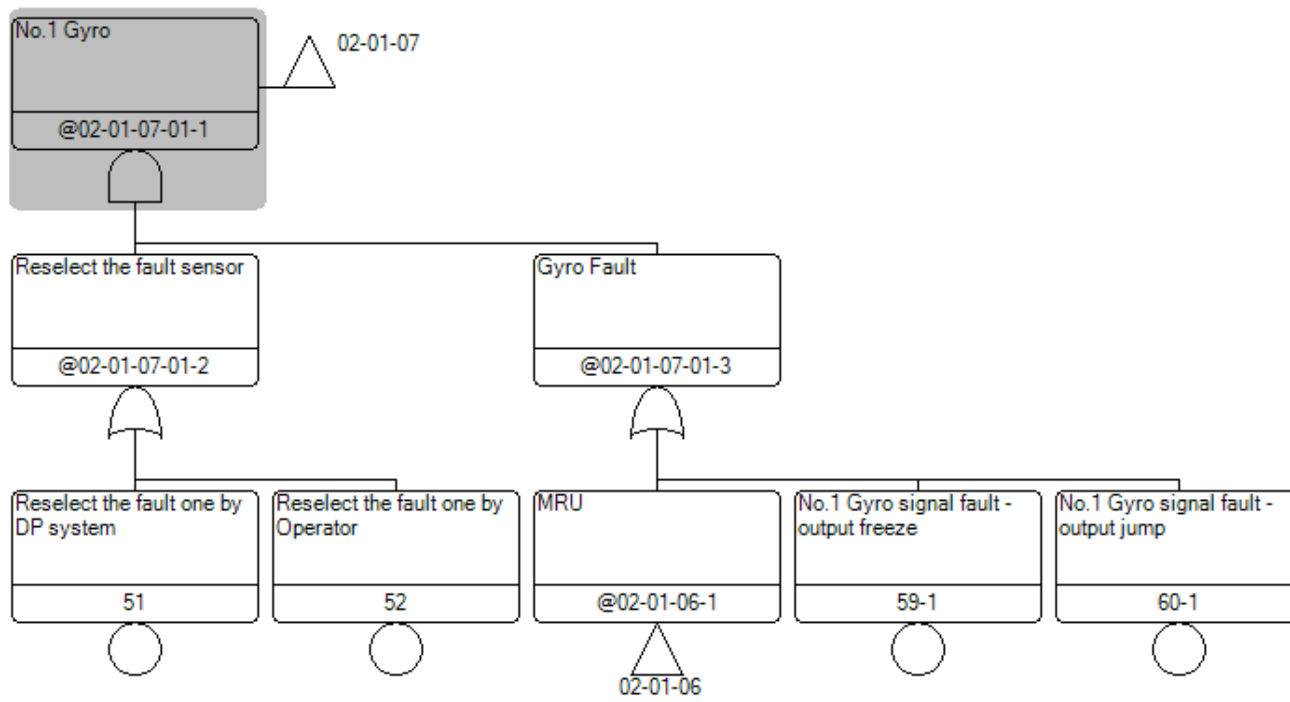

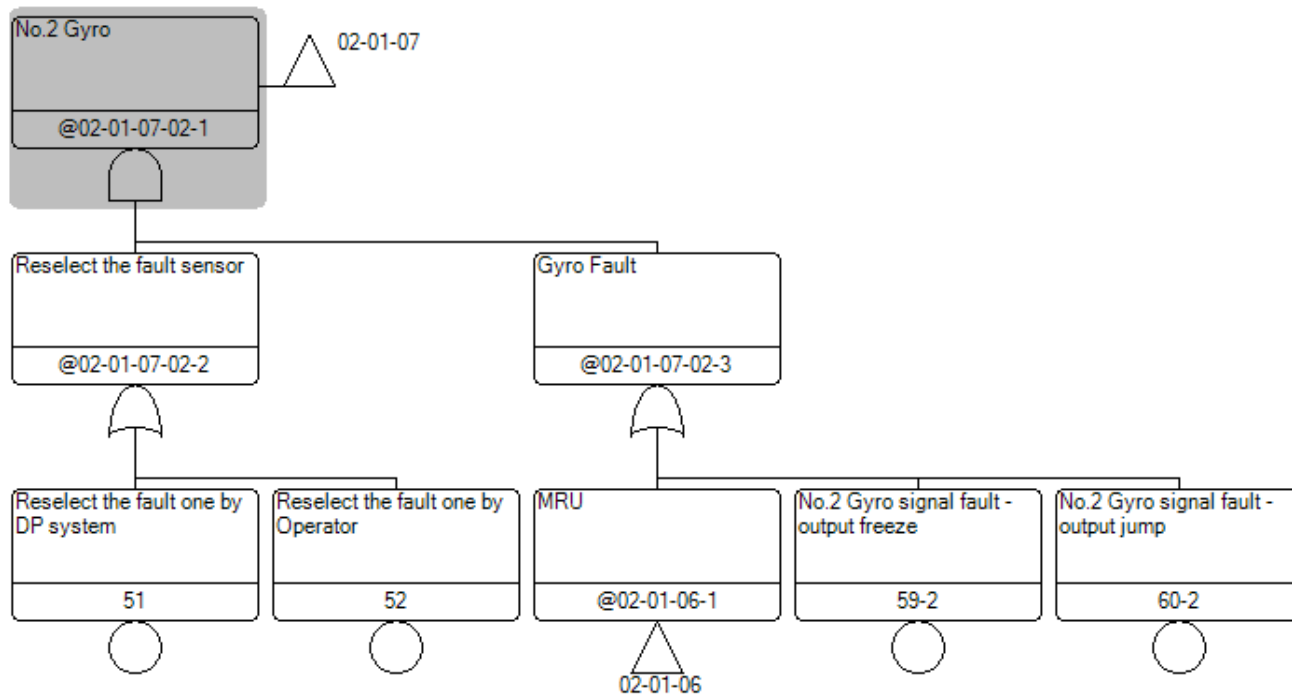

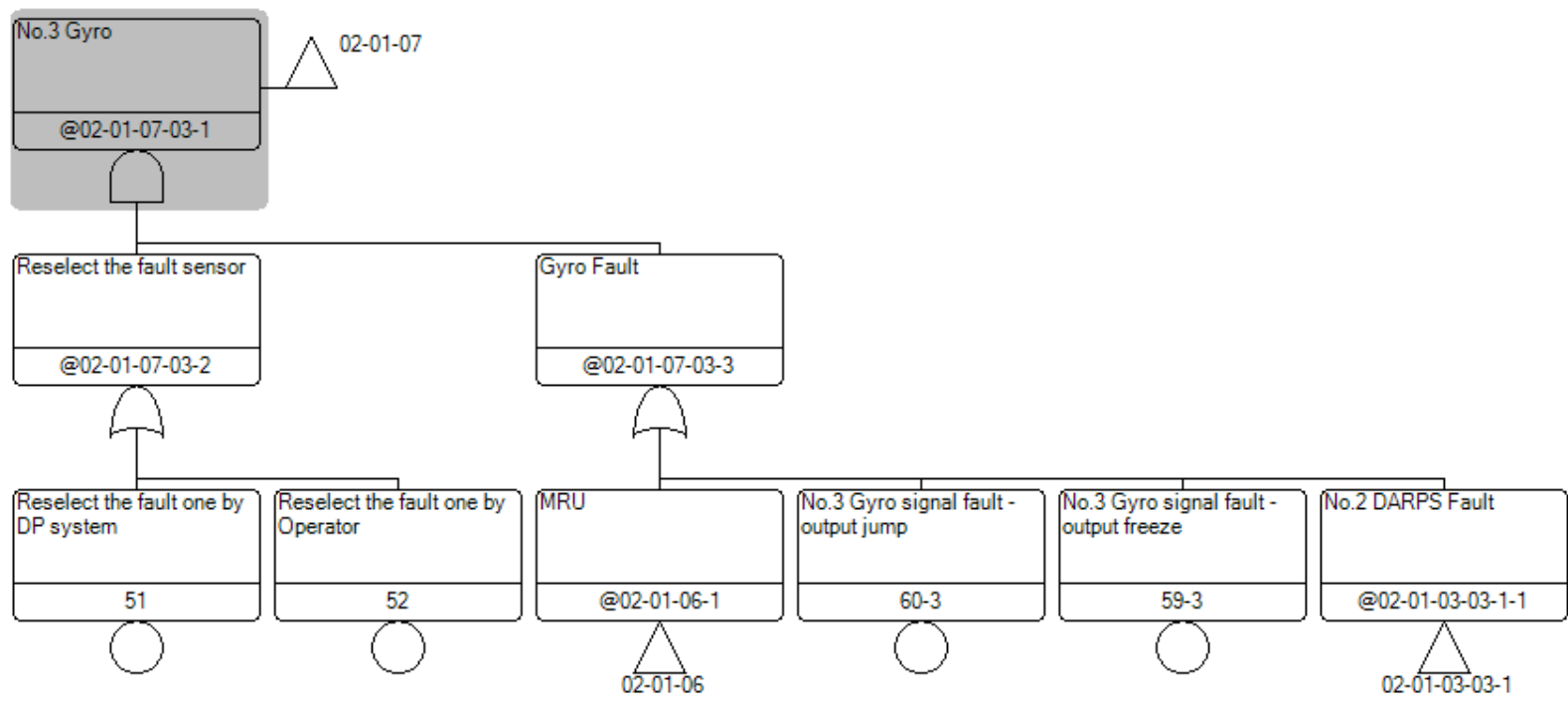

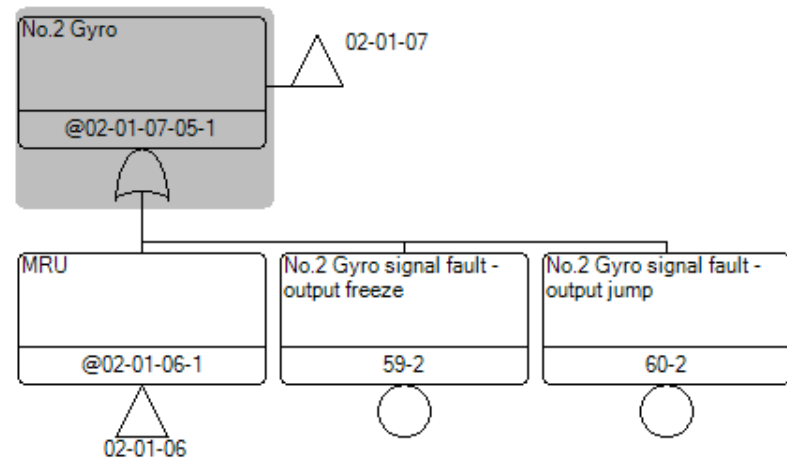
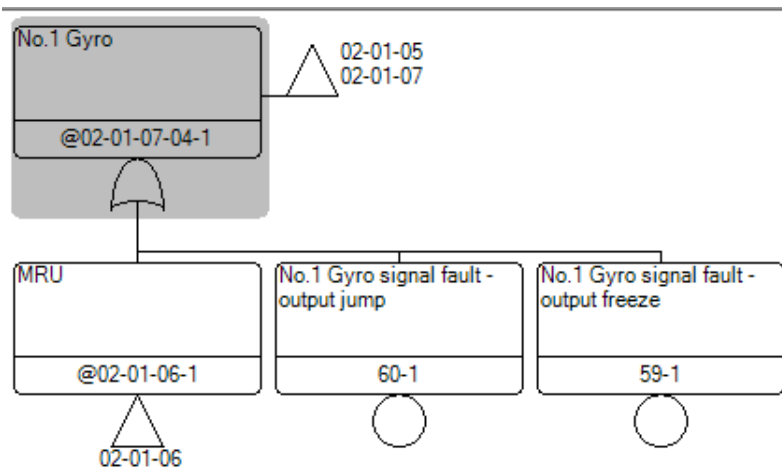

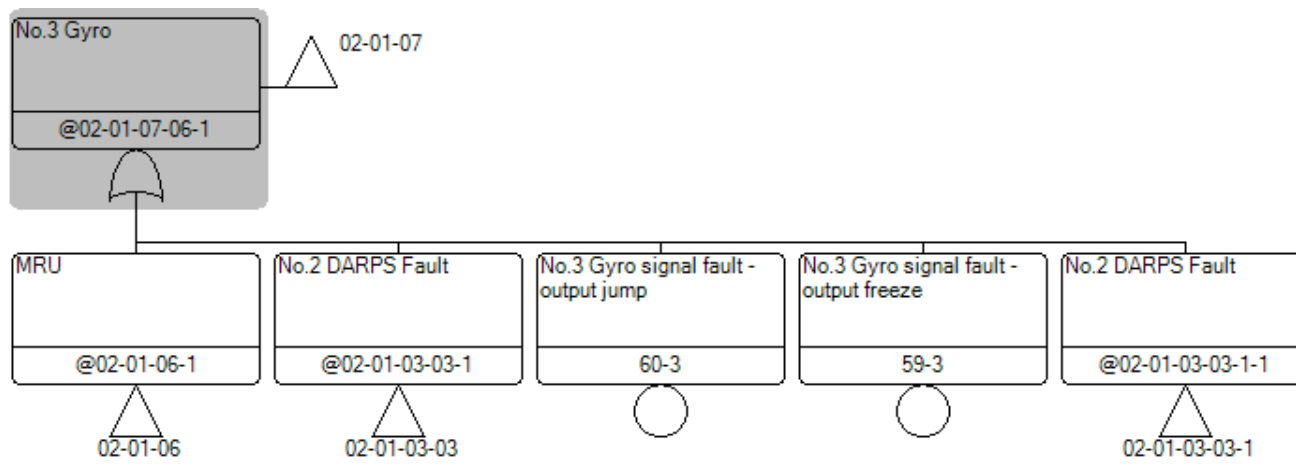

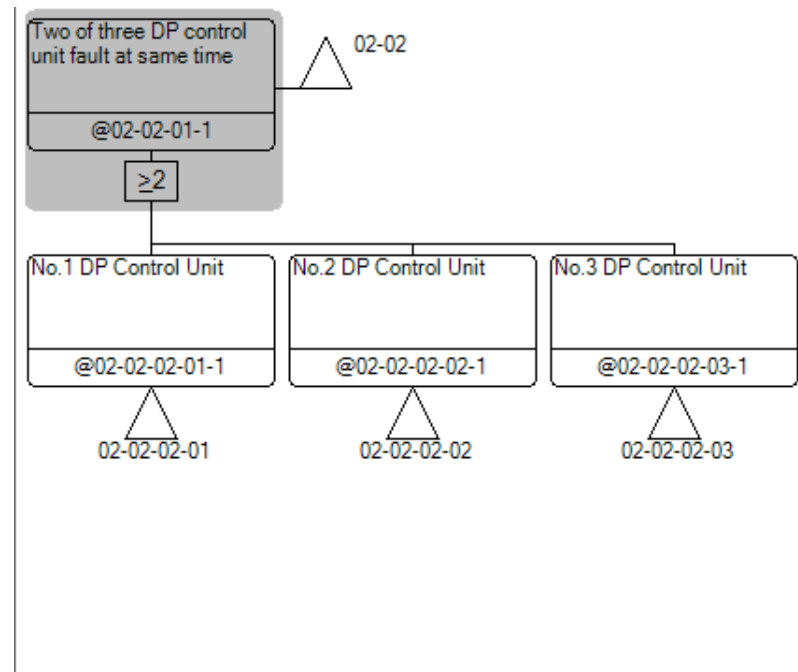
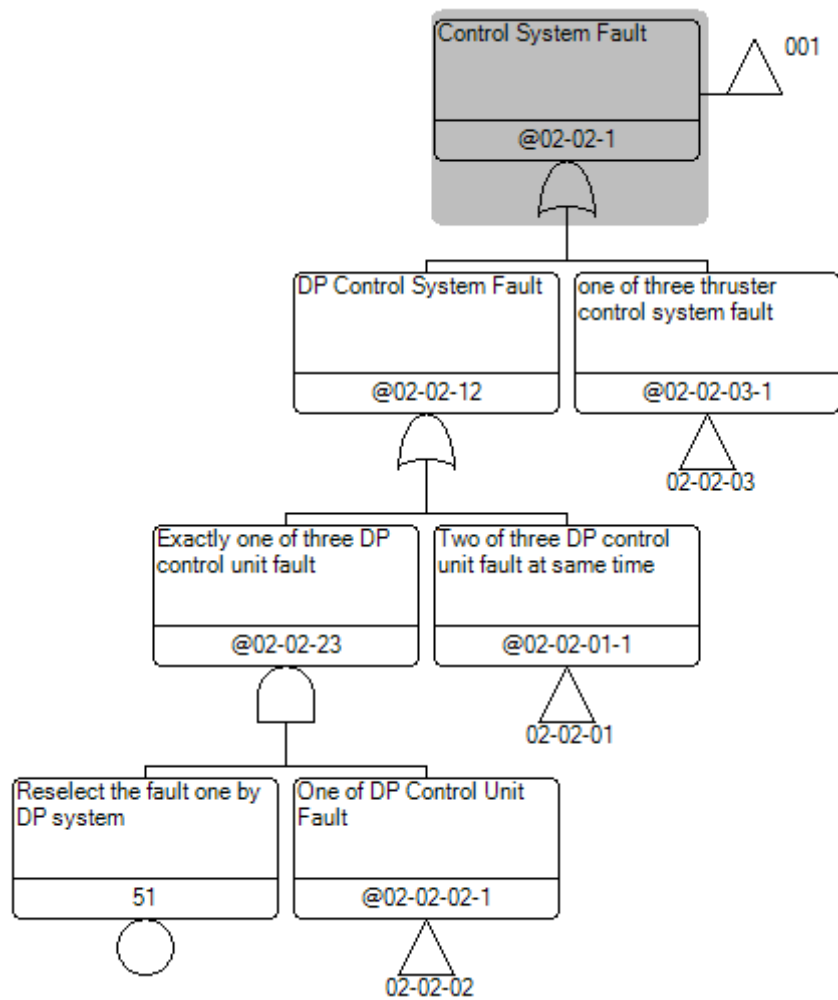

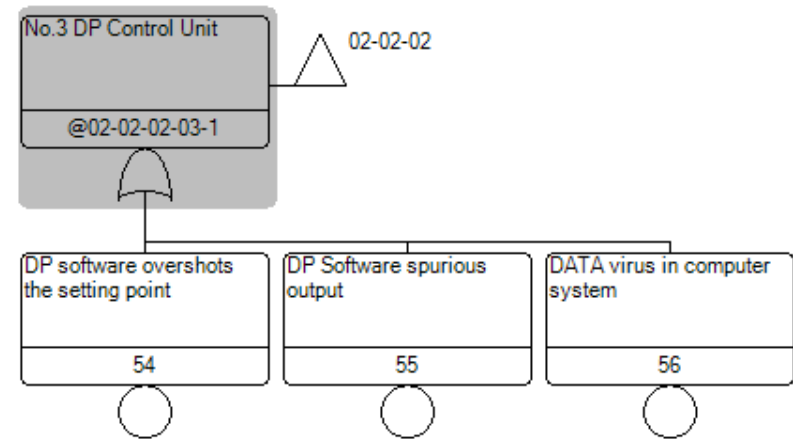
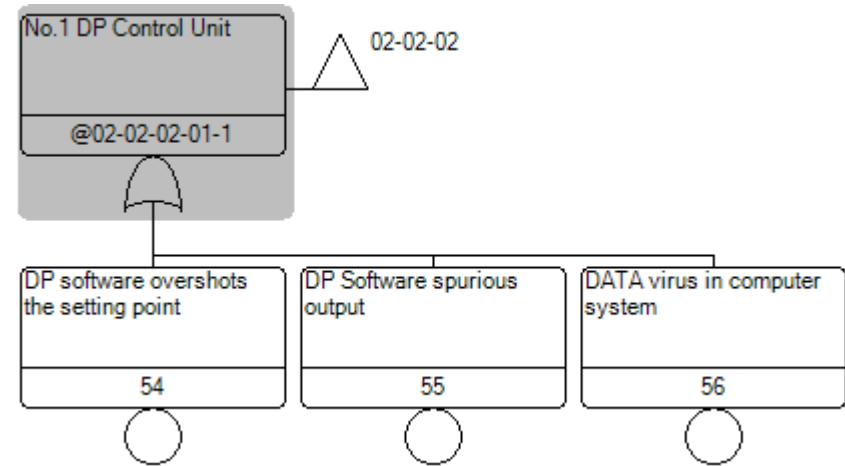
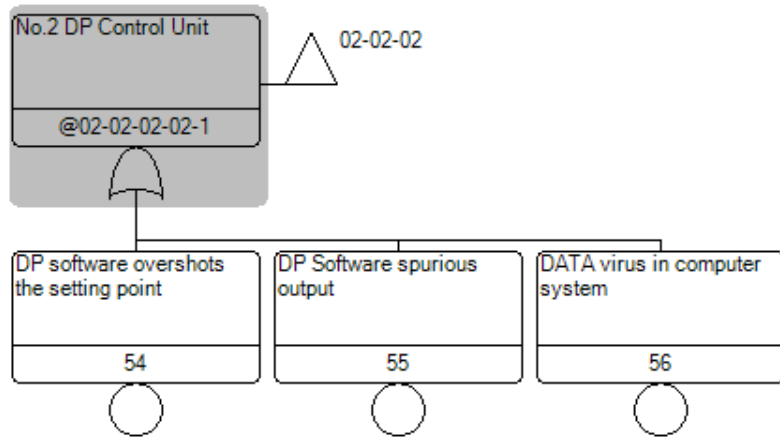
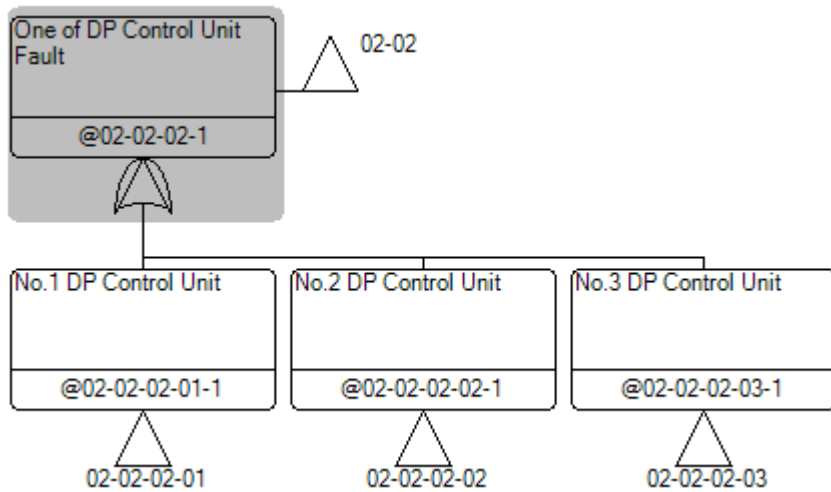

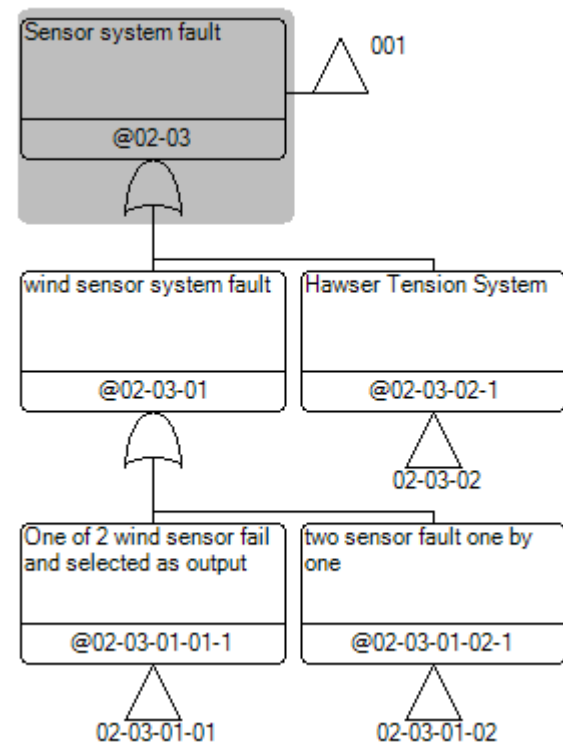
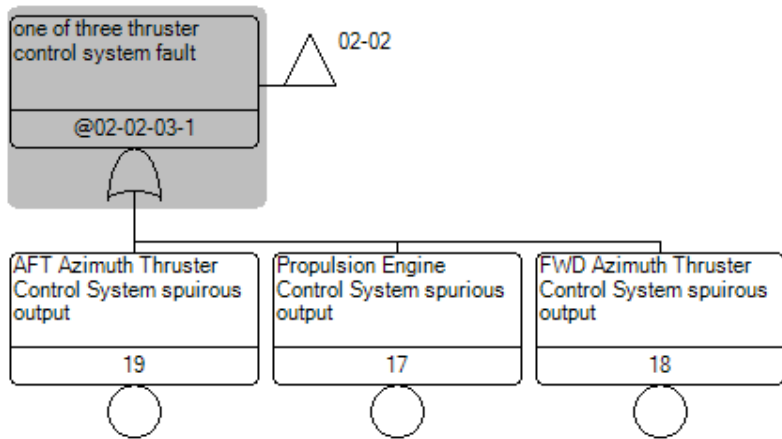

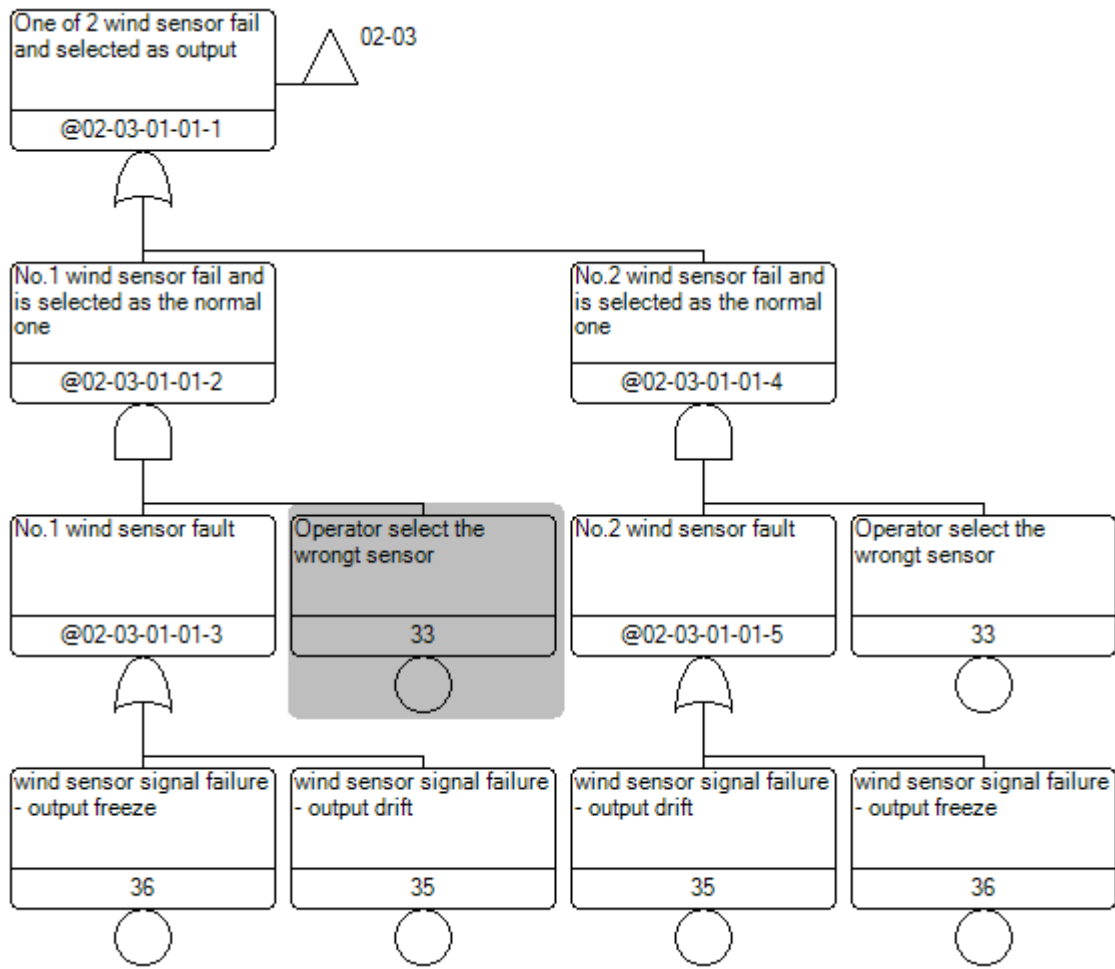

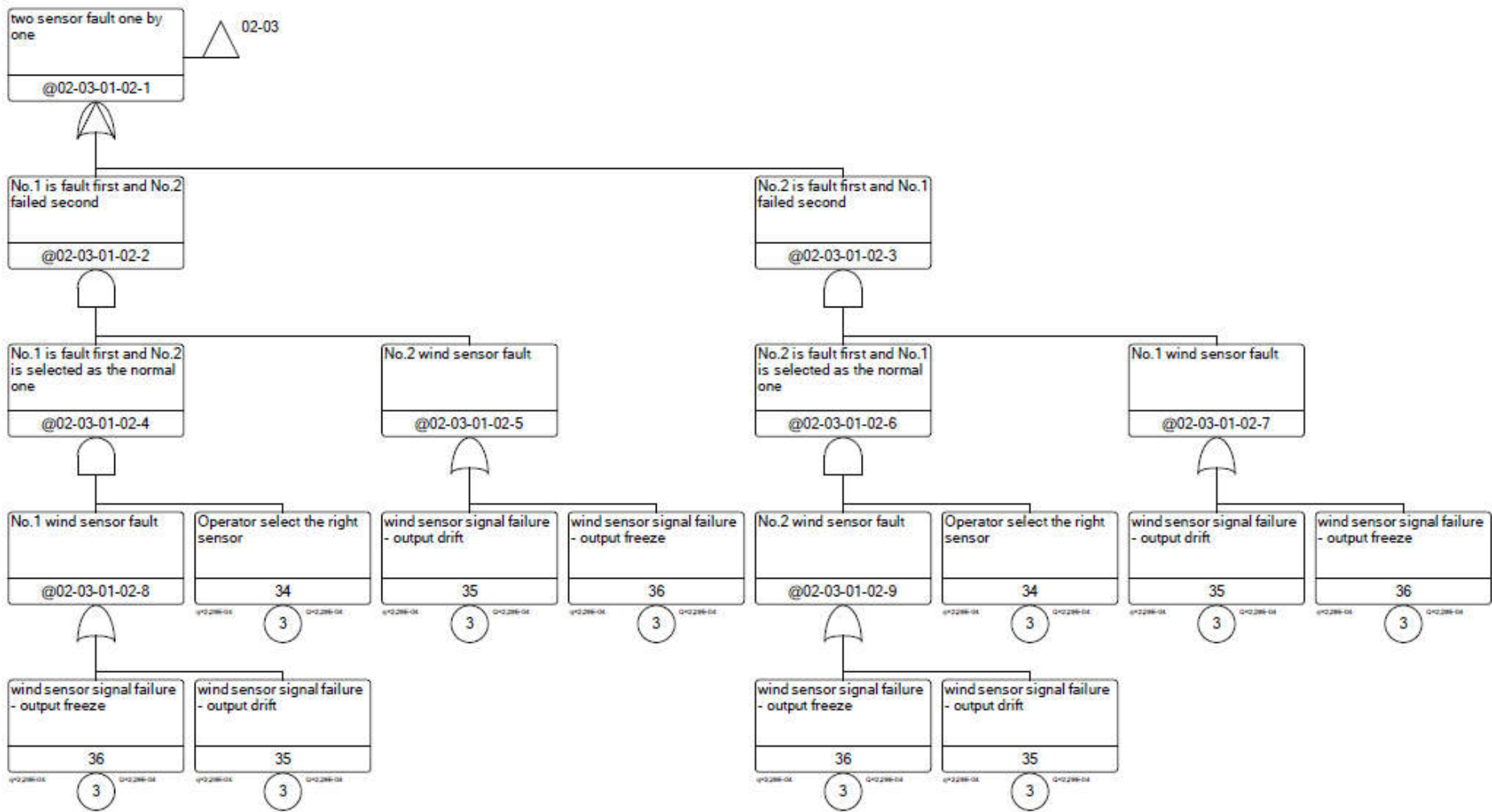

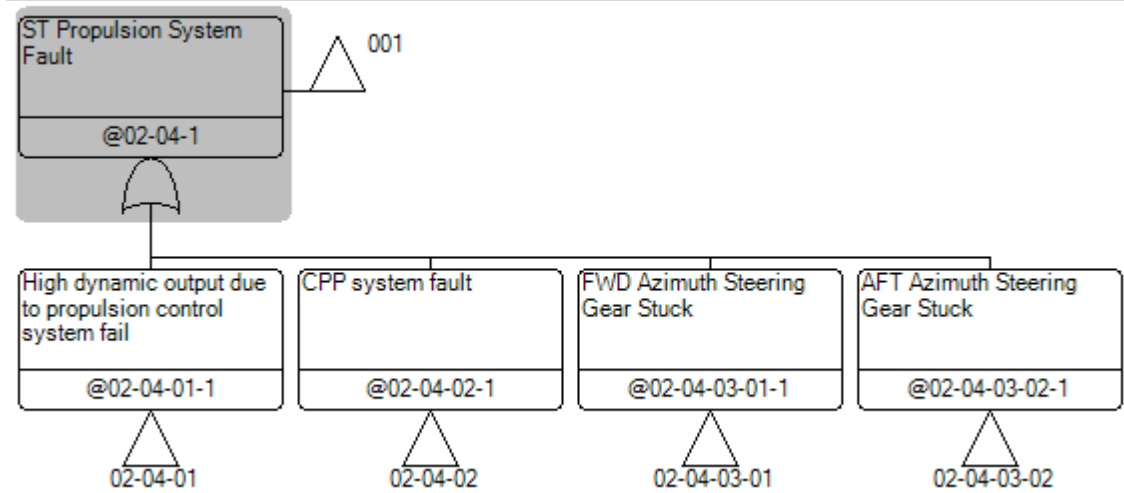
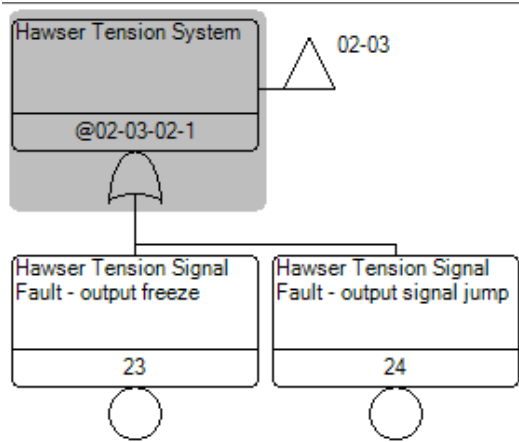

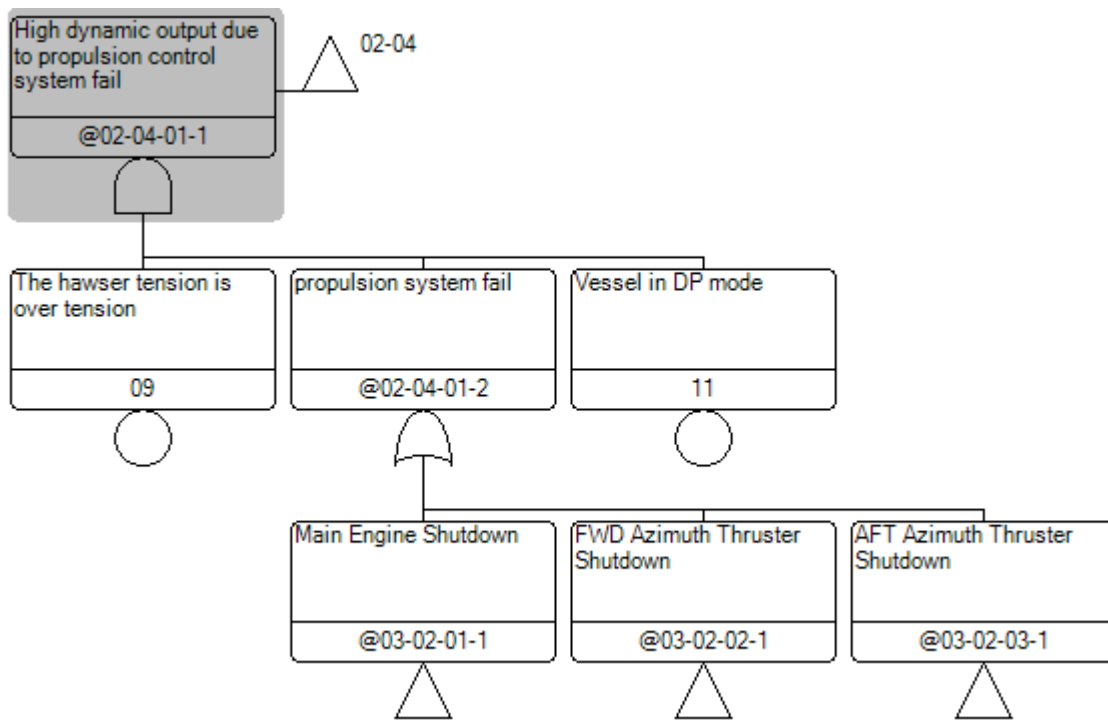

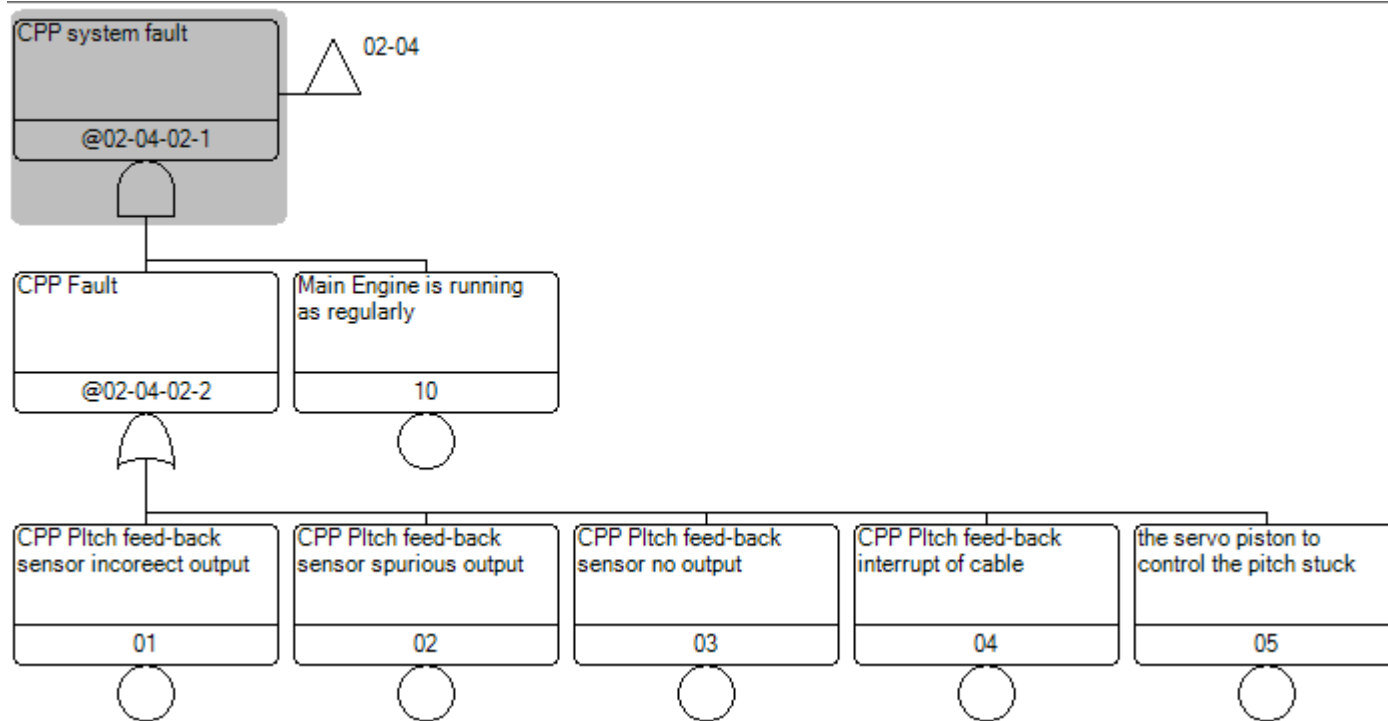

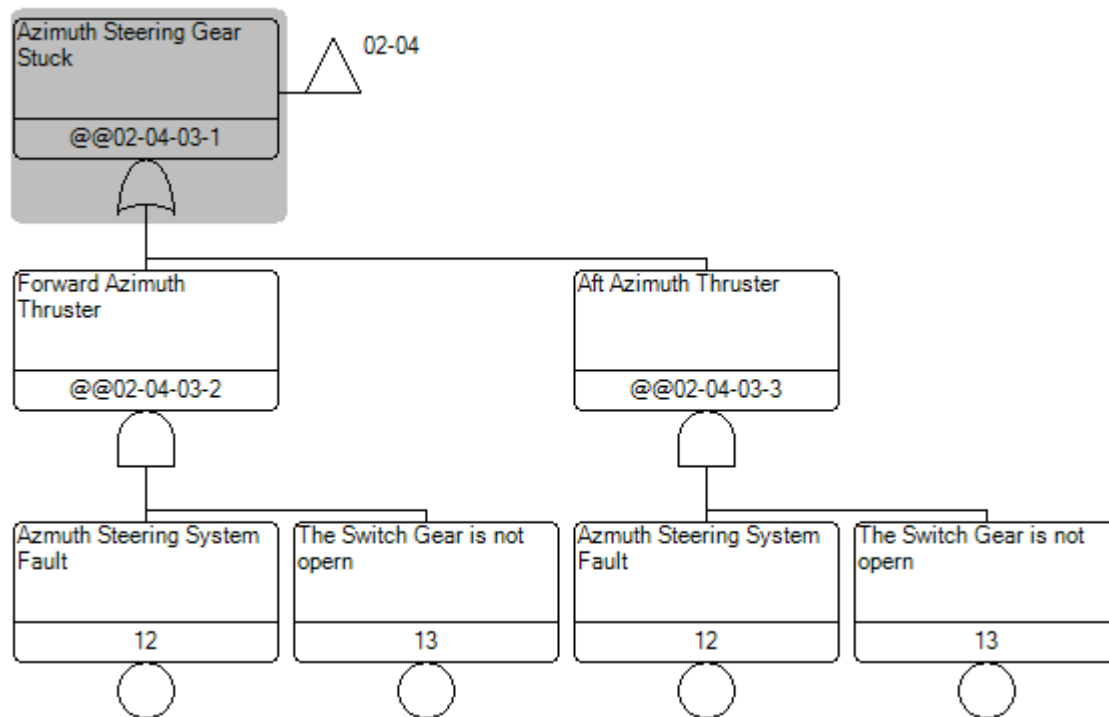

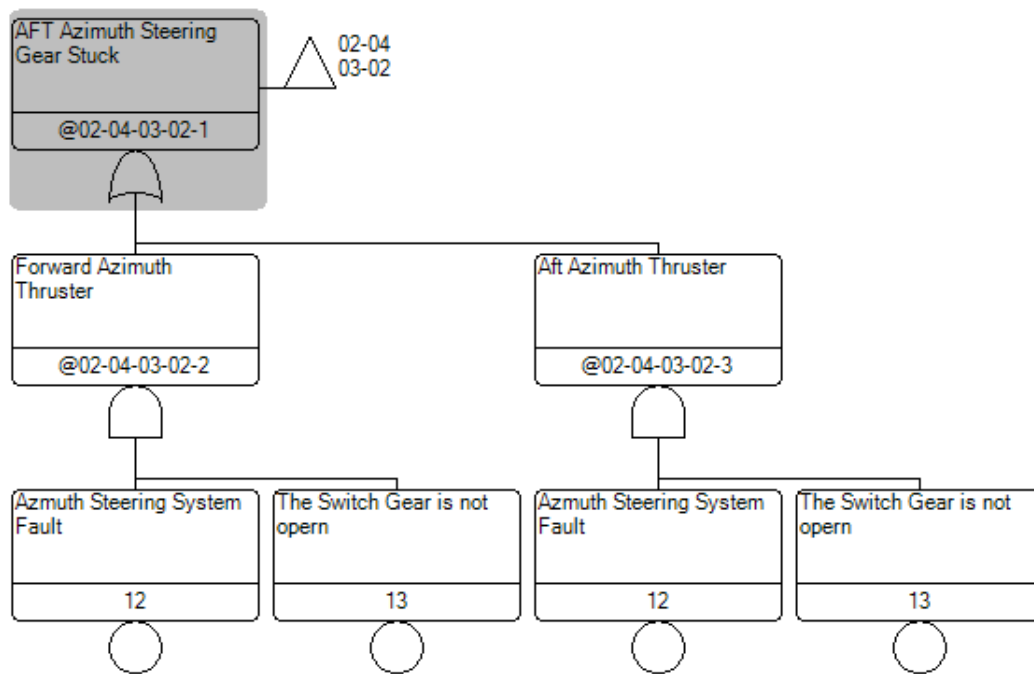

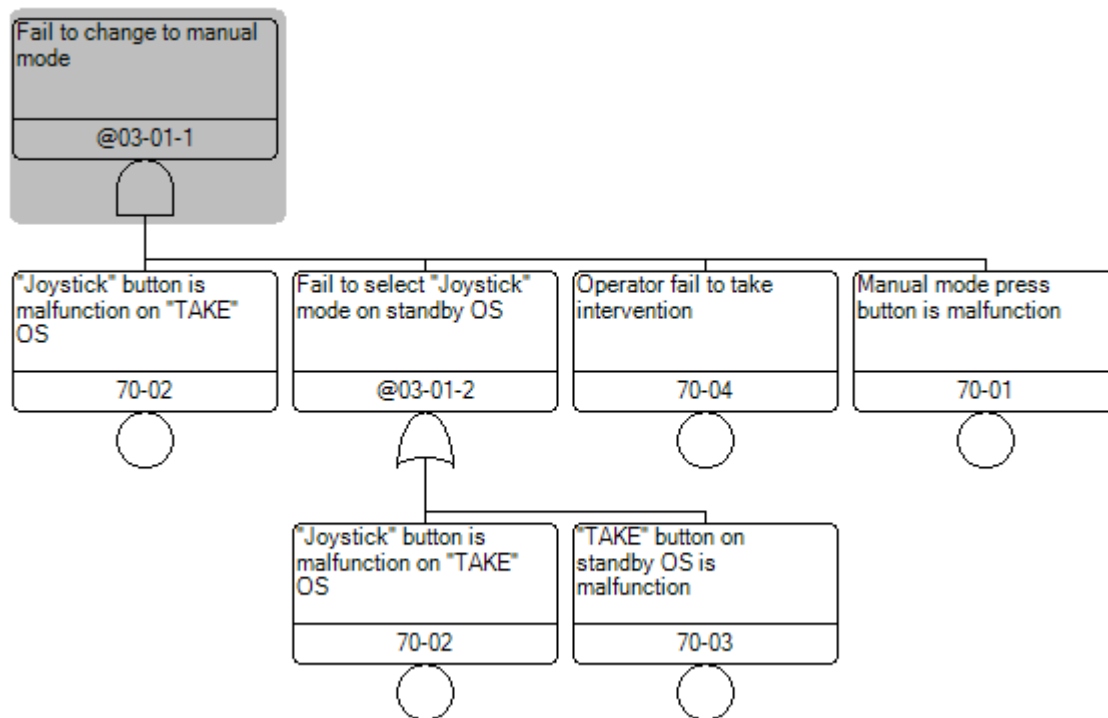

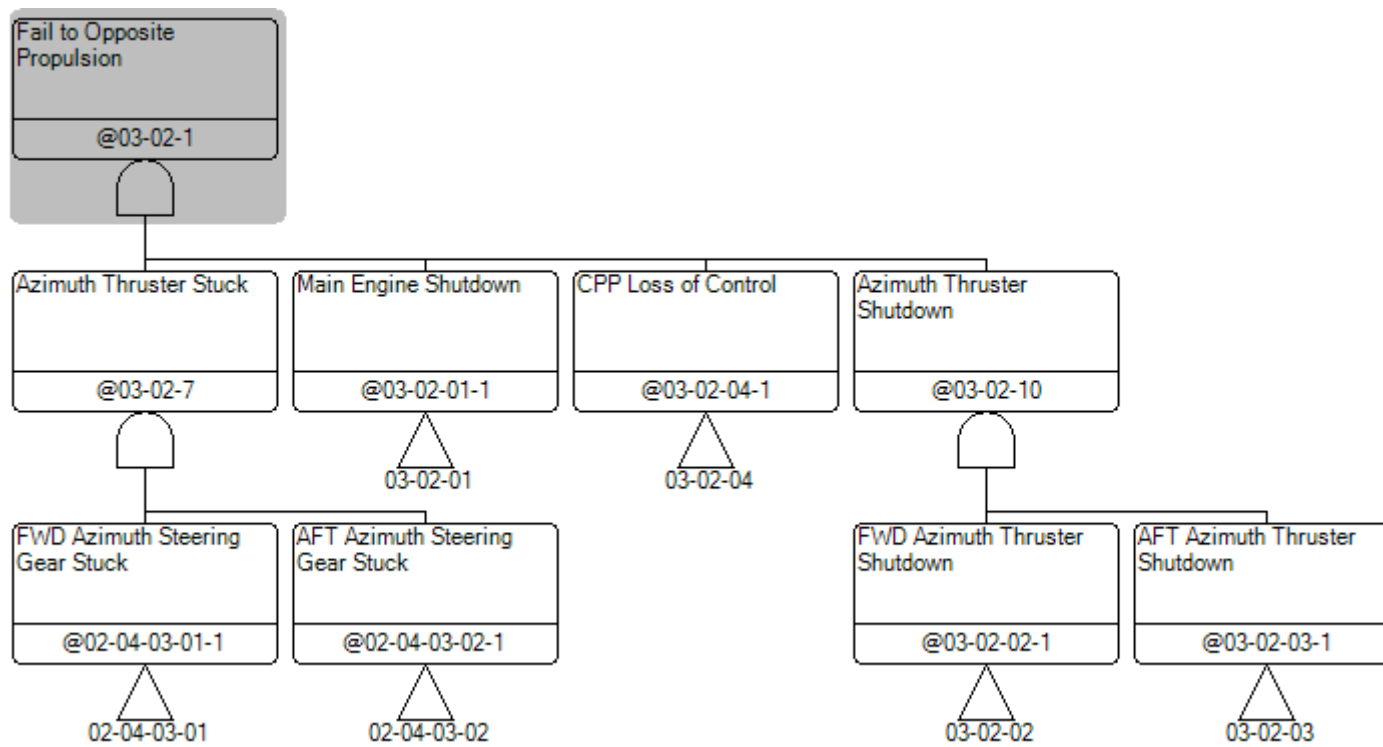

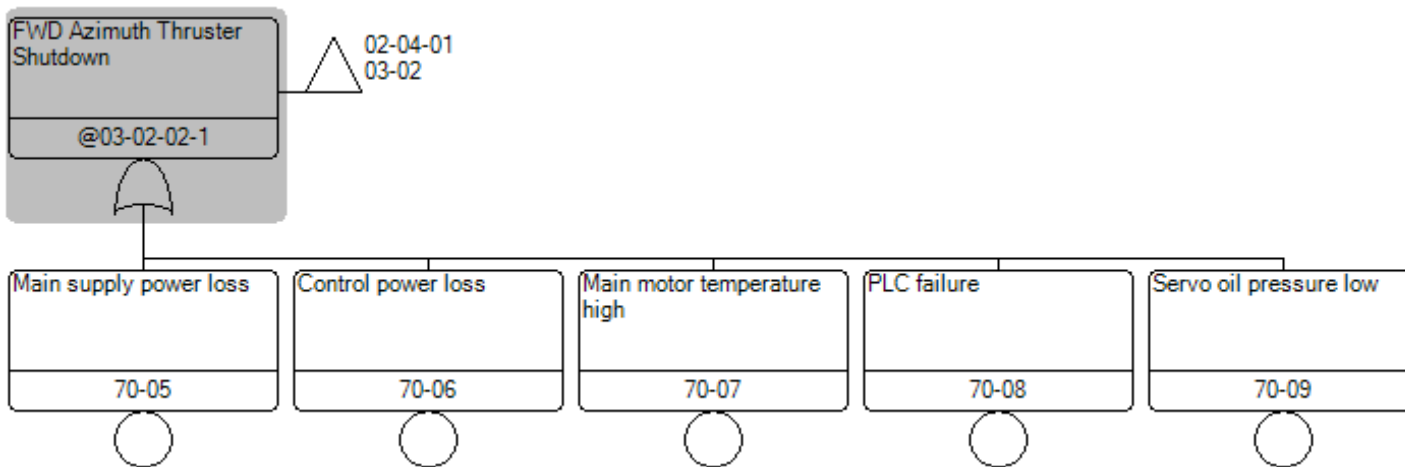
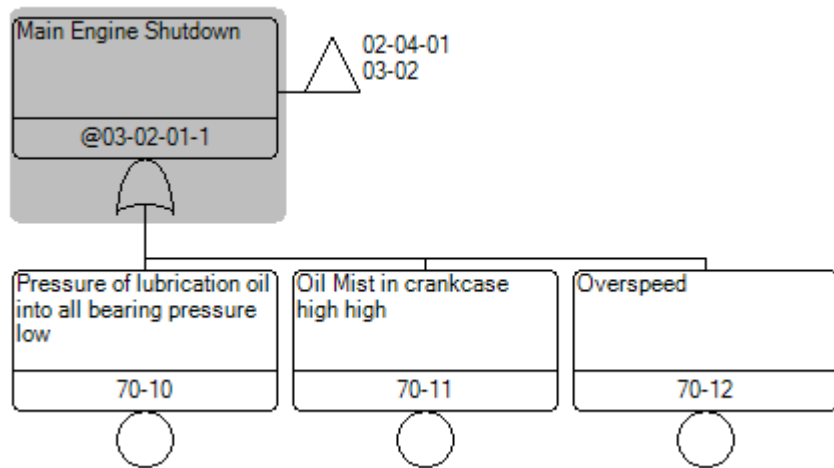

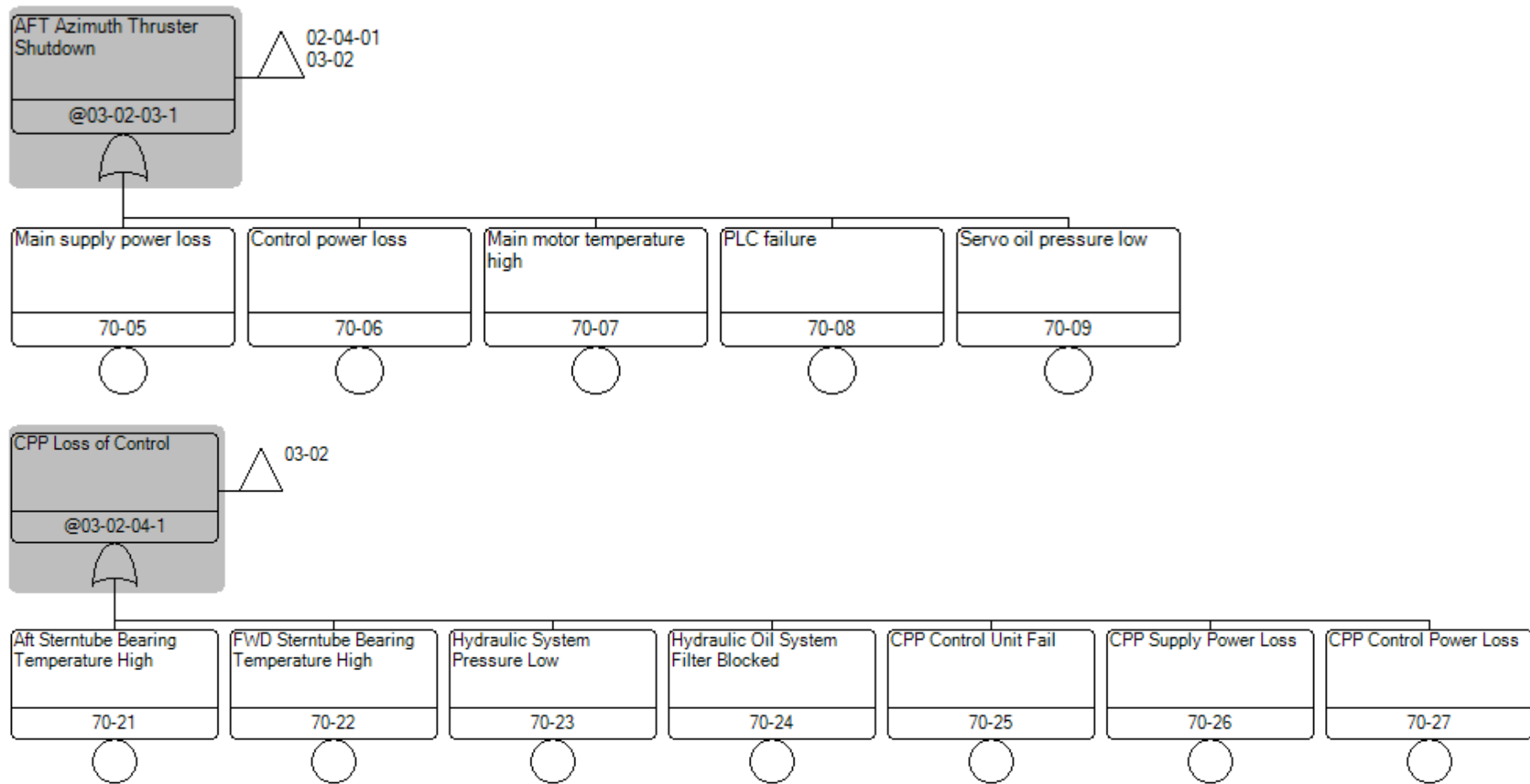

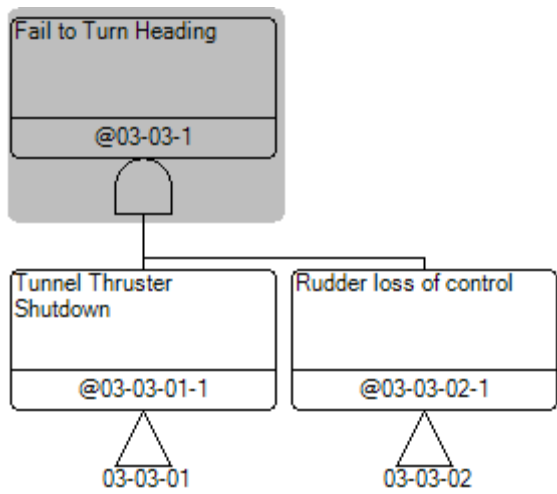

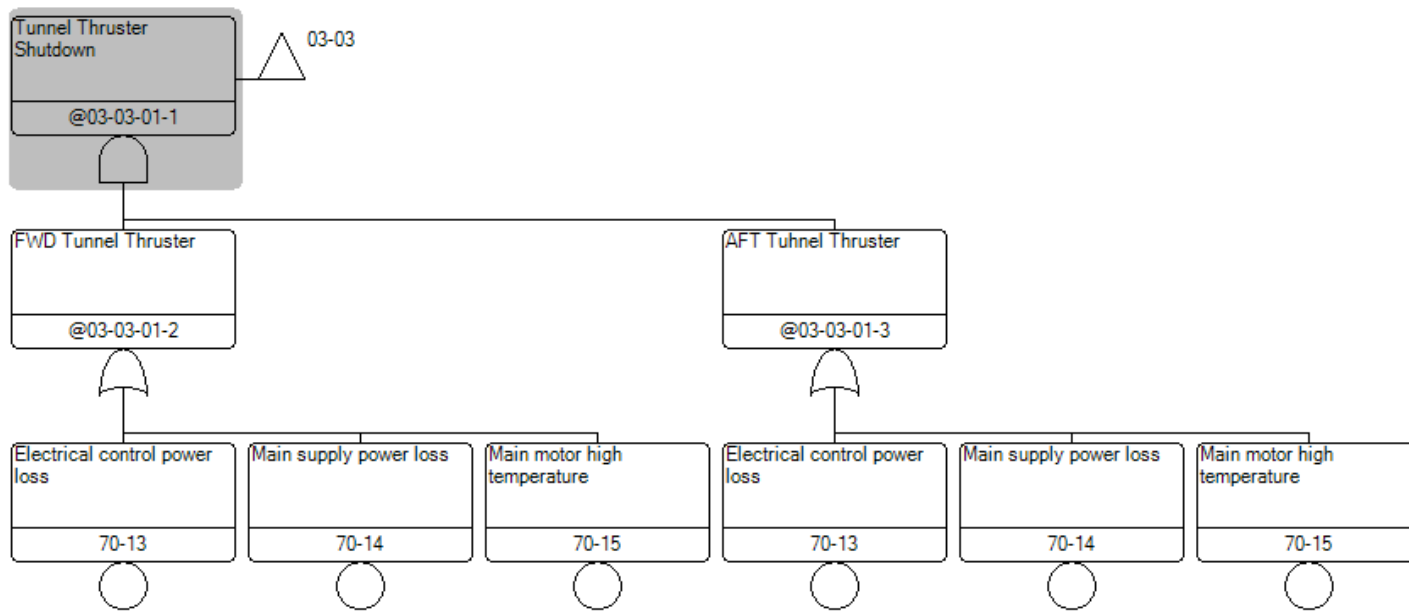

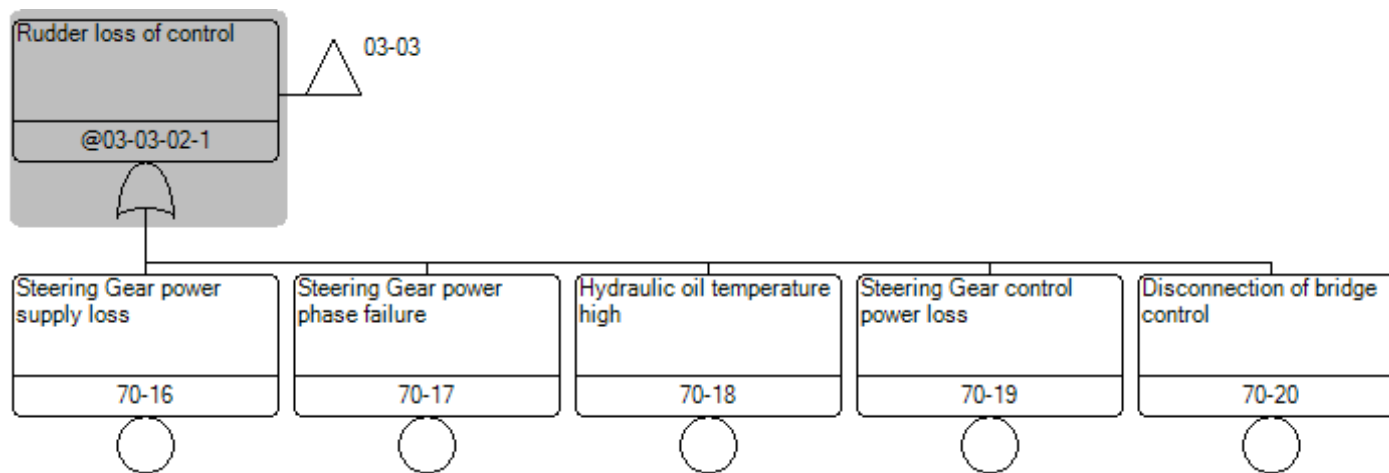

Appendix III

Minimum Cut Sets for Fault Tree Analysis of Shuttle Tanker Drive-off

No.	Event 1	Event 2	Event 3
1	16		
2	19		
3	24		
4	23		
5	17		
6	56		
7	54		
8	18		
9	55		
10	15		
11	01	10	
12	05	10	
13	02	10	
14	03	10	
15	04	10	
16	09	11	70-10
17	09	11	70-07
18	09	11	70-06
19	09	11	70-05
20	09	11	70-12
21	09	11	70-09
22	09	11	70-08
23	09	11	70-11
24	26	61	
25	25	52	
26	28-1	51	
27	26	52	
28	60-2	61	
29	33	36	
30	25	51	
31	30-2	52	
32	29-1	61	
33	30-1	61	
34	57-3	58-1	
35	57-1	57-3	
36	59-2	61	
37	27-2	61	
38	52	57-3	

39	33	35	
40	29-1	52	
41	26	51	
42	30-1	52	
43	52	59-2	
44	21	61	
45	28-2	61	
46	52	60-2	
47	29-1	51	
48	22	61	
49	30-1	51	
50	51	59-2	
51	21	52	
52	27-2	52	
53	27-1	61	
54	51	57-3	
55	51	60-2	
56	51	57-2	
57	22	52	
58	51	58-2	
59	59-3	60-2	
60	52	57-2	
61	21	51	
62	28-2	52	
63	51	60-1	
64	60-3	61	
65	59-3	61	
66	29-2	61	
67	30-2	61	
68	31	52	
69	32	52	
70	52	59-1	
71	52	60-1	
72	51	58-1	
73	51	57-1	
74	51	60-3	
75	51	59-3	
76	29-2	51	
77	30-2	51	
78	29-2	59-2	
79	30-2	59-2	
80	29-2	60-2	
81	30-2	60-2	

82	29-1	29-2	
83	29-1	30-2	
84	29-2	30-1	
85	30-1	30-2	
86	57-2	58-1	
87	57-1	57-2	
88	58-1	58-2	
89	57-1	58-2	
90	27-1	27-2	
91	27-1	28-2	
92	27-2	28-1	
93	28-1	28-2	
94	29-1	60-3	
95	29-1	59-3	
96	30-1	60-3	
97	30-1	59-3	
98	59-2	60-3	
99	59-2	59-3	
100	60-2	60-3	
101	52	58-2	
102	31	61	
103	22	51	
104	32	61	
105	27-1	52	
106	52	60-3	
107	27-2	51	
108	28-1	61	
109	28-1	52	
110	59-1	61	
111	52	59-3	
112	60-1	61	
113	52	58-1	
114	57-2	57-3	
115	28-2	51	
116	12	13	
117	52	57-1	
118	31	51	
119	57-3	58-2	
120	32	51	
121	51	59-1	
122	29-2	52	
123	25	61	
124	27-1	51	

125	52	58-3	
126	51	58-3	

Appendix IV

Event Tree Analysis for the Risk Picture of Different Drive-off Scenario at different Shuttle Tanker and FPSO Layouts

PFM: Shuttle tanker keep heading to the stern of FPSO and 80m distance to FPSO

	F1	F2	F3	F4	F5	F6	F7						
Initiate Event	Heading at the Collision Course to FPSO	Abnormal Signal Detection out of 30	Making Decision out of 53s	Fail to Manual Takeover	Fail to Operate Thruster	Fail to Change Heading	Contacting With FPSO Stern	No.	Conseq.	Freq	Conseq. Value	Risk	Seq.
9.00E-04	0.6	0.6						1	Level A	3.24E-04	10	3.24E-03	
	0.4	0.4	0.5					2	Level A	1.08E-04	10	1.08E-03	F2
			0.5	0.1				3	Level A	1.08E-05	10	1.08E-04	F2-F3
				0.9	0.2	0.6		4	Level A	1.17E-05	10	1.17E-04	F2-F3-F4
					0.8	0.4	0.51	5	Level B	3.97E-06	6	2.38E-05	F2-F3-F4-F6
						0.49		6	Level C	3.81E-06	4	1.52E-05	F2-F3-F4-F6-F7
								7	Level B	2.38E-05	6	1.43E-04	F2-F3-F4-F5
								8	Level C	2.29E-05	4	9.14E-05	F2-F3-F4-F5-F7
								9	Level B	1.59E-05	6	9.52E-05	F2-F3-F4-F5-F6
								10	Level C	1.52E-05	4	6.10E-05	F2-F3-F4-F5-F6-F7
								11	Level B	3.60E-05	6	2.16E-04	F1
								12	Level C	6.48E-05	4	2.59E-04	F1-F4
								13	Level D	2.59E-04	0	0.00E+00	F1-F4-F5
Total Risk:												5.45E-03	

PFM: Shuttle tanker keep heading to the stern of FPSO and 80m distance to FPSO

	F1	F2	F3	F4	F5	F6	F7						
Initiate Event	Heading at the Collision Course to FPSO	Abnormal Signal Detection out of 30	Making Decision out of 53s	Fail to Manual Takeover	Fail to Operate Thruster	Fail to Change Heading	Contacting With FPSO Stern	No.	Conseq.	Freq	Conseq. Value	Risk	Seq.
9.00E-04	0.6	0.6						1	Level A	3.24E-04	10	3.24E-03	
	0.4	0.4	0.5					2	Level A	1.08E-04	10	1.08E-03	F2
			0.5	0.1				3	Level A	1.08E-05	10	1.08E-04	F2-F3
				0.9	0.2	0.6		4	Level A	1.17E-05	10	1.17E-04	F2-F3-F4
					0.8	0.4	0.51	5	Level B	3.97E-06	6	2.38E-05	F2-F3-F4-F6
							0.49	6	Level C	3.81E-06	4	1.52E-05	F2-F3-F4-F6-F7
								7	Level B	2.38E-05	6	1.43E-04	F2-F3-F4-F5
								8	Level C	2.29E-05	4	9.14E-05	F2-F3-F4-F5-F7
								9	Level B	1.59E-05	6	9.52E-05	F2-F3-F4-F5-F6
								10	Level C	1.52E-05	4	6.10E-05	F2-F3-F4-F5-F6-F7
								11	Level B	3.60E-05	6	2.16E-04	F1
								12	Level C	6.48E-05	4	2.59E-04	F1-F4
								13	Level D	2.59E-04	0	0.00E+00	F1-F4-F5
Total Risk:												5.45E-03	

PFM: Shuttle tanker keep deviation angle heading to the stern of FPSO

	F1	F2	F3	F4	F5	F6	F7						
Initiate Event	Heading at the Collision Course to FPSO	Abnormal Signal Detection out of 30	Making Decision out of 53s	Fail to Manual Takeover	Fail to Operate Thruster	Fail to Change Heading	Contacting With FPSO Stern	No.	Conseq.	Freq	Conseq. Value	Risk	Seq.
9.00E-04	0.1	0.1						1	Level A	9.00E-06	10	9.00E-05	
	0.9	0.9	0.1					2	Level A	8.10E-06	10	8.10E-05	F2
			0.9	0.01				3	Level A	7.29E-07	10	7.29E-06	F2-F3
				0.99	0.1	0.1		4	Level A	7.22E-07	10	7.22E-06	F2-F3-F4
					0.9	0.9	0.3	5	Level B	1.95E-06	6	1.17E-05	F2-F3-F4-F6
						0.7		6	Level C	4.55E-06	4	1.82E-05	F2-F3-F4-F6-F7
								7	Level B	1.95E-06	6	1.17E-05	F2-F3-F4-F5
								8	Level C	4.55E-06	4	1.82E-05	F2-F3-F4-F5-F7
								9	Level B	1.75E-05	6	1.05E-04	F2-F3-F4-F5-F6
								10	Level C	4.09E-05	4	1.64E-04	F2-F3-F4-F5-F6-F7
								11	Level B	8.10E-06	6	4.86E-05	F1
								12	Level C	8.02E-05	4	3.21E-04	F1-F4
								13	Level D	7.22E-04	0	0.00E+00	F1-F4-F5
Total Risk:											8.84E-04		

PFM: Shuttle tanker installing ORDSS keep heading to the stern of FPSO and 80m distance to FPSO

	F1	F2	F3	F4	F5	F6	F7						
Initiate Event	Heading at the Collision Course to FPSO	Abnormal Signal Detection out of 30	Making Decision out of 53s	Fail to Manual Takeover	Fail to Operate Thruster	Fail to Change Heading	Contacting With FPSO Stern	No.	Conseq.	Freq	Conseq. Value	Risk	Seq.
9.00E-04	0.6	0.01						1	Level A	5.40E-06	10	5.40E-05	
	0.4	0.99	0.01					2	Level A	5.35E-06	10	5.35E-05	F2
			0.99	0.0001				3	Level A	5.29E-08	10	5.29E-07	F2-F3
				0.9999	0.0001	0.0001		4	Level A	5.29E-12	10	5.29E-11	F2-F3-F4
					0.9999	0.9999	0.1	5	Level B	5.29E-09	6	3.17E-08	F2-F3-F4-F6
							0.9	6	Level C	4.76E-08	4	1.90E-07	F2-F3-F4-F6-F7
								7	Level B	5.29E-09	6	3.17E-08	F2-F3-F4-F5
								8	Level C	4.76E-08	4	1.90E-07	F2-F3-F4-F5-F7
								9	Level B	5.29E-05	6	3.17E-04	F2-F3-F4-F5-F6
								10	Level C	4.76E-04	4	1.90E-03	F2-F3-F4-F5-F6-F7
								11	Level B	3.60E-08	6	2.16E-07	F1
								12	Level C	3.60E-08	4	1.44E-07	F1-F4
								13	Level D	3.60E-04	0	0.00E+00	F1-F4-F5
Total Risk:												2.33E-03	

Appendix V

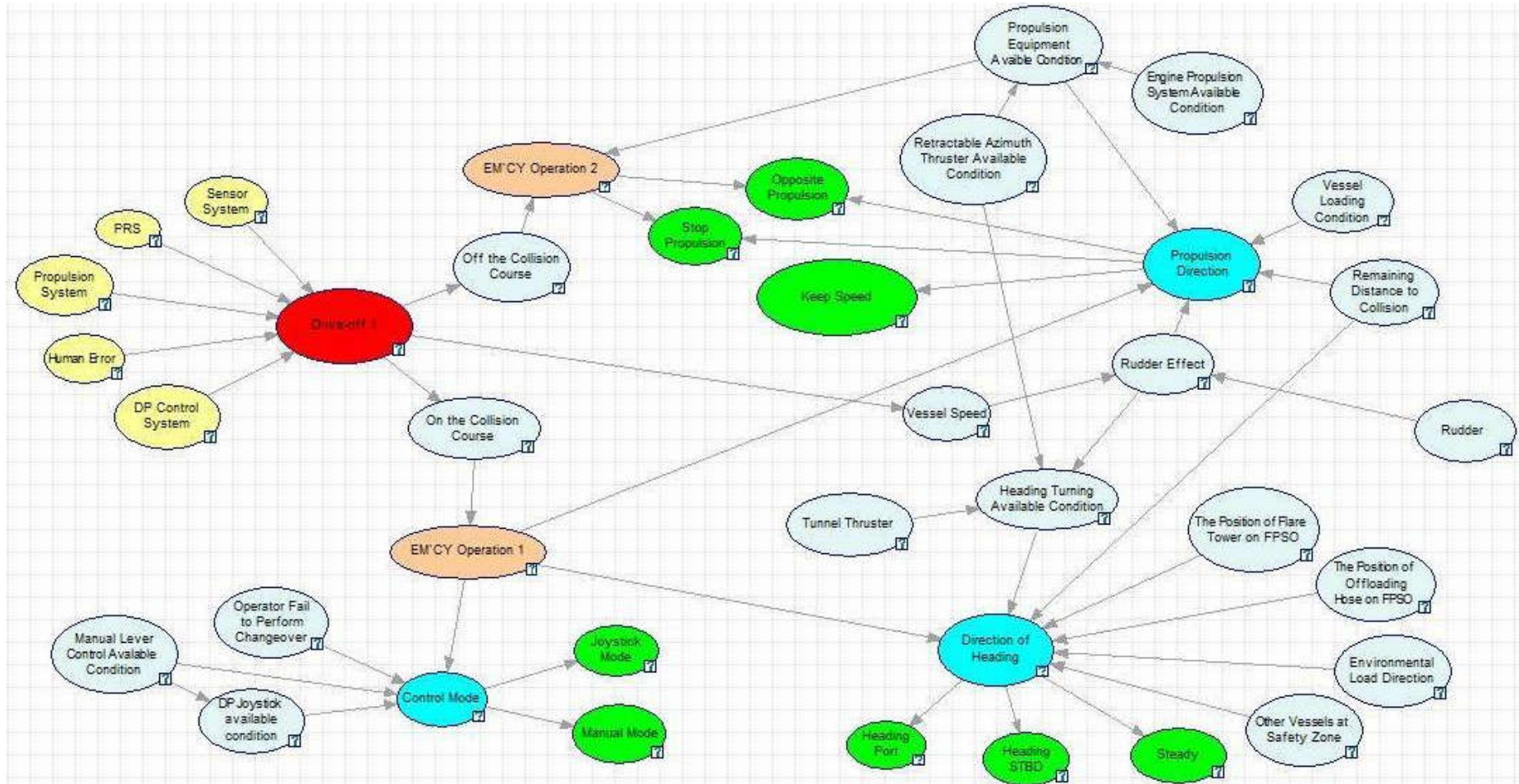

Appendix VI

Propulsion Equipment Available Condition Table

Sr	Engine Propulsion Available Condition		Azimuth Propulsion Available Condition		Propulsion Equipment Available Condition	
	Available	Not Available	Available	Not Available	Available	Not Available
1	x		x		x	
2	x			x	x	
3		x	x		x	
4		x		x		x

Rudder Effect Available Condition Table

Sr	Vessel Speed		Rudder		Rudder Effect	
	High	Low	Available	Not Available	Available	Not Available
1	x		x		x	
2	x			x		x
3		x	x			x
4		x		x		x

Heading Turning Available Condition Table

Sr	Rudder Effect	Tunnel Thruster	Azimuth Thruster	Heading Turning Available Condition
----	---------------	-----------------	------------------	-------------------------------------

	Available	Not Available	Available	Not Available	Available	Not Available	Available	Not Available
1	Any one available						x	
2		x		x		x		x

Propulsion Direction Condition Table

Sr	Drive-off		Propulsion Equipment Available Condition		Rudder Effect		Remaining Distance to FPSO		Vessel Loading Condition		Propulsion Direction		
	Off the Collision Course	On the Collision Course	Available	Not Available	Available	Not Available	Enough	Not Enough	Heavy	Light	Opposite Propulsion	Stop Propulsion	Ahead Propulsion
1		x	x			x	No Influence				x		
2		x		x		x	No Influence					x	
3		x	x		No Influence		x			x	x		
4		x	x		x			x	No Influence				x
5		x	x		x		No Influence		x				x
6	x		x		No Influence						x		
7	x			x								x	

Direction of Heading Condition Table

Sr	Drive-off		Heading Turning Equipment Condition		Remaining Distance to FPSO		Environment Load Direction			Position of Flare Tower on FPSO		
	Off the Collision Course	On the Collision Course	Available	Not Available	Enough for Collision Avoiding Operation	Not Enough for Collision Avoiding Operation	Port	Mid or Weak Load	STBD	Port	Mid	STBD
1		x	x			x				x		
2		x	x			x						x
3		x	x			x						x
4		x	x			x						x
5		x	x		x		x					
6		x	x		x				x			
7		x	x		x			x				
8		x	x		x			x				
9		x	x		x					x		
10		x	x		x							x
11		x	x		x							x
12		x	x		x							x
13	x											

Part 1

Sr	Position of Offloading Hose on FPSO			Nearest Vessel to ST At Safety Zone			Direct of Heading			Note
	Port	Mid	STBD	Port	No	STBD	Heading PORT	Steady	Heading STBD	
1									x	Priority: 1. Position of flare tower 2. Position of Offloading Hose
2							x			
3	x								x	
4			x				x			
5									x	Environment Load is the only factor
6							x			
7				x					x	With Wind from Heading Direction or no wind, the nearest vessel to ST is the only factor
8						x	x			
9									x	With Wind from Heading Direction or no wind and no vessel to ST, Priority is as below, 1. Position of flare tower 2. Position of Offloading Hose
10							x			
11	x								x	
12			x				x			
13								x		

Part 2

Control Mode Selection Condition Table

Sr	DPO Fail to Perform Change Over		Manual Lever Control Available Condition		DP Joystick Available Condition		Control Mode Selection			Note
	Yes	No	Available	Not Available	Available	Not Available	Joystick Mode	Manual Mode	Fail	
1	x								x	Manual Lever Control Mode is the first priority, since the power output is high than DP Joystick Mode
2		x		x	x		x			
3		x	x					x		
4		x		x		x			x	

Appendix VII

Sr	Equipment Available Condition						STEP 3						STEP 5						NOTE
	RD	CPP	BT	AT	BA	AA	RD	CPP	BT	AT	BA	AA	RD	CPP	BT	AT	BA	AA	
1	x	x	x	x	x	x	S	FAH	S	P	S	P	M	FAH	S	S	S	S	FORWARD AND AFT AT SAME SPEED
2	x	x	x	x	x		S	FAH	S	P	S		P	FAH	S	S	S		
3	x	x	x	x		x	S	FAH	S	P		P	S	FAH	S	S		S	
4	x	x	x		x	x	S	FAH	S		S	P	P	FAH	S		S	S	
5	x	x		x	x	x	S	FAH		P	S	P	S	FAH		S	S	S	HEADING KEEP
6	x		x	x	x	x	S		S	P	FAH	FAH	M		S	S	SWA	SWA	
7		x	x	x	x	x		FAS	S	P	S	P		FAH	S	S	FAH	FAH	1. FAS IN STEP 1, GAIN MORE TURNING TIME, FAH IN STEP 2, LEAVE THE AREA AS SOON AS POSSIBLE
8	x	x	x	x			S	FAH	S	P			M	FAH	S	S			
9	x	x	x		x		S	FAH	S		S		P	FAH	S		S		
10	x	x	x			x	S	FAH	S			P	M	FAH	S			S	
11	x	x		x	x		S	FAH		P	S		M	FAH		S	S		
12	x	x		x		x	S	FAH		P		P	S	FAH		S		FAH	
13	x	x			x	x	S	FAH			S	P	M	FAH			S	S	
14	x		x	x	x		S		S	P	FAH		M		S	S	FAH		
15	x		x	x		x	S		S	P		FAH	M		S	S		FAH	

16	x		x		x	x	S		S		FAH	P	M		S		FAH	S		
17	x			x	x	x	S			P	S	FAH	M			S	S	FAH		
18		x	x	x	x			FAS	S	P	S			FAH	S	S	FAH		1. FAS IN STEP 1, GAIN MORE TURNING TIME, FAH IN STEP 2, LEAVE THE AREA AS SOON AS POSSIBLE	
19		x	x	x		x		FAS	S	P				FAH	S	S				
20		x	x		x	x		FAS	S		FAS	P		FAH	S		FAH	S		
21		x		x	x	x		FAS		P	S	P		FAH		S	S	FAH		
22			x	x	x	x			S	P	S	P			S	S	FAH	FAH		
23	x	x	x				S	FAH	S				P	FAH	S					
24	x	x		x			S	FAH		P			S	FAH		S				
25	x	x			x		S	FAH			S		P	FAH		S				
26	x	x				x	S	FAH				P	S	FAH				S		
27	x		x	x			S		S	P			M		S	S				
28	x		x		x		S		S		FAH		P		S	FAH				
29	x		x			x	S		S			FAH	P		S			FAH		
30	x			x	x		S			P	FAH		S			S	FAH			
31	x			x		x	S					FAH						FAH		
32	x				x	x	S				FAH	FAH	S				FAH	SWA		
33		x	x	x				FAS	S	P				FAH	S	S				
34		x	x		x			FAS	S		S			FAH	ST		FAH		90 DEGREE TO FPSO	
35		x	x			x		FAS	S			P		FAH	ST			FAH		
36		x		x	x			FAS		P	S			FAH		ST	FAH			
37		x		x		x		FAS		P		P		FAH		S		S		

38		x			x	x		FAS			S	P		FAH			S	S	
39			x	x	x				S	P	S				S	S	FAH		
40			x	x		x			S	P		P			S	S		FAH	
41			x		x	x			S		S	P			S		FAH	SWA	
42				x	x	x				P	S	P				S	SWA	FAH	
43	x	x					S	FAH					S	FAH					
44	x		x				S		S				P		S				STOP TAIL TO FPSO, KEEP HEADING TURNING FURTHER, USE ENVIRONMENT LOAD
45	x			x			S			P			S			S			SHIP ALONGSIDE FACE ENVIRONMENT LOAD
46	x				x		S				FAH						FAH		
47	x					x	S					FAH						FAH	
48		x	x					FAS	S					FAH	ST				90 DEGREE TO FPSO
49		x		x				FAS		P				FAH		ST			
50		x			x			FAS			S			FAH			FAH		
51		x				x		FAS				P		FAH				FAH	
52			x	x					S	P					S	S			
53			x		x				S		S				S		SWA		
54			x			x			S			P			S			SWA	

55				x	x					P	S					S	SWA	
56				x		x				P		P				S		SWA
57					x	x					S	P					SWA	SWA
58	x												S					
59		x						FAS						FAS				
60			x						S						S			
61				x						P						P		
62					x						S						SWA	
63						x						P						PWA
64																		

PREPARE FOR
FIRE FIGHTING
AND OIL
LEAKAGE

Note:

SWA: STBD with Angle

PWA: Port with Angle

FAH: Full Speed Ahead

FAS: Full Speed Astern

Appendix VIII

Position Reference System Selection Table

Sr	Abosult System		Relative Ssystem					Each Weight	DGPS	DARPS	DGPS and DARPS Total	Probability(1E-8)	Comment
	DGPS	DGPS	DARPS	DARPS	Artmis	Fanbeam	HiPAP						
1	DGPS	DGPS	DARPS	DARPS	Artmis	Fanbeam	HiPAP	14.3	28.6	28.6	57.1	5.244	Voting System select the DARPS or DGPS, or both
2	DGPS	DGPS	DARPS	DARPS	Artmis	Fanbeam		16.7	33.3	33.3	66.7	4.615	
3	DGPS	DGPS	DARPS	DARPS	Artmis			20.0	40.0	40.0	80.0	4.3	
4	DGPS	DGPS	DARPS		Artmis	Fanbeam	HiPAP	16.7	33.3	16.7	50.0	3.776	Voting System select the DGPS, or DGPS& DARPS
5	DGPS	DGPS	DARPS		Artmis	Fanbeam		20.0	40.0	20.0	60.0	3.146	
6	DGPS	DGPS	DARPS		Artmis			25.0	50.0	25.0	75.0	2.832	
7		DGPS	DARPS	DARPS	Artmis	Fanbeam	HiPAP	16.7	16.7	33.3	50.0	4.72	Voting System select the DARPS, or DGPS& DARPS
8		DGPS	DARPS	DARPS	Artmis	Fanbeam		20.0	20.0	40.0	60.0	4.09	
9		DGPS	DARPS	DARPS	Artmis			25.0	25.0	50.0	75.0	3.776	
10		DGPS	DARPS		Artmis	Fanbeam	HiPAP	20.0	20.0	20.0	40.0	2.832	Safety for Voting System
11		DGPS	DARPS		Artmis	Fanbeam		25.0	25.0	25.0	50.0	2.202	Voting System select the DARPS or DGPS, or both
12		DGPS	DARPS		Artmis			33.3	33.3	33.3	66.6	1.888	
13		DGPS			Artmis	Fanbeam	HiPAP	25.0	25.0	0.0	25.0	2.202	Safety for Voting System
14		DGPS			Artmis	Fanbeam		33.3	33.3	0.0	33.3	1.573	

Appendix IX

Formula for Vessel Maneuvering Resistance and Propulsion Force

- Total Resistance Force

Water Total Resistance Coefficient

$$C_{Ts} = C_{Rm} + (C_{Fs} + \Delta C_F) \cdot (1 + K_o) + C_A + C_{AAs} + C_{BDs}$$

Water Total Resistance

$$R_{Ts} = C_{Ts} \cdot \frac{\rho_s}{2} \cdot V_s^2 \cdot S_s$$

C_{Rm} : It is residual resistance coefficient, and it can be acquired from model scale towing test.

C_{Fs} : Frictional Resistance coefficient for flat plate

$$C_{Fs} = \frac{0.075}{(\log R_{ms} - 2)^2}$$

ΔC_F : Roughness allowance

$$\Delta C_F = [110.31 \cdot (H \cdot V_s)^{0.21} - 403.33] \cdot C_{Fs}^2$$

Where H = hull surface roughness in μ (1E-3 mm). $H = 150 \mu$

And V_s = ship speed in m/s

Only ΔC_F values > 0 are used

K_o : Form Factor

$$K_o = 0.6\varphi + 75\varphi^2$$

Where $\varphi = \frac{C_B}{L_{WL}} \sqrt{(T_{AP} + T_{FP}) \cdot B}$

C_B : Block coefficient of the ship

T_A : Draught at the aft perpendicular

T_F : Draught at the forward perpendicular

B: Maximum breadth of the hull

L_{WL} : Length of the waterline

C_{AA} : Air resistance Coefficient

$$C_{AA} = 0.001 \cdot \frac{A_T}{S}$$

A_T : Transverse projected area of ship/model above the waterline

C_{BD} : Transom stern resistance

$$C_{BD} = \frac{0.029 \cdot \left(S_B/S\right)^{3/2}}{(C_F)^{1/2}}$$

S: Wetted Area

S_B : Area of transom stern below the waterline

C_A : Empirical correlation coefficient determined from trial analysis

● Total Propulsion Force

Engine Propulsion

$$T = \frac{P_B}{V} \times \frac{\eta_o \times \eta_R \times \eta_S}{1-w} \times 1.852 \text{ m}$$

PB: Engine Power V: m/s

Propeller efficiency

$$\eta_o = \frac{P_T}{P_D} = \frac{T \times V_A}{Q \times 2\pi \times n} = \frac{K_T}{K_Q} \times \frac{J}{2\pi}$$

Advance Coefficient

$$J = \frac{V_A}{n \times d}$$

Thrust Coefficient

$$K_T = \frac{T}{\rho \times n^2 \times d^4}$$

Torque coefficient

$$K_Q = \frac{Q}{\rho \times n^2 \times d^4}$$

Propeller Torque

$$Q = \frac{P_D}{2\pi \times n}$$

η_R Relative Rotative Efficiency, Single shaft: 1.0~1.07 / Twin shaft:

0.98

Shaft efficiency

$$\eta_s = \frac{P_D}{P_B}$$

