



NTNU – Trondheim
Norwegian University of
Science and Technology

Alternative Methods for Tubing Removal

Stian Sætre

Subsea Technology

Submission date: June 2014

Supervisor: Sigbjørn Sangesland, IPT

Norwegian University of Science and Technology
Department of Petroleum Engineering and Applied Geophysics

MASTEROPPGAVE

Våren 2014

for stud. techn. Stian Sætre

Analyse av metoder for permanent brønnplugging

Bakgrunn:

Plugging av petroleumsbrønner krever god tetning mellom stålrør, sement og formasjon. I enkelte tilfeller er det nødvendig å fjerne foringsrør før det settes sementplugg i brønnen. I tillegg kreves det kutting og fjerning av foringsrør nær havbunnen.

Fortrinnsvis bør det benyttes et mindre fartøy uten bruk av konvensjonelt stigerør.

Deloppgaver:

1. Beskrive typiske brønnkonstruksjoner på norsk sokkel og de krav som stilles til permanent brønnplugging
2. Foreslå og evaluere alternative metoder og løsninger for fjerning av foringsrør. Velg konstruksjonsløsning og utfør nødvendige analyser og beregninger.

Estimer potensiell kostnadsbesparelse ved anvendelse av en slik metode sammenlignet med alternative metoder.

Oppgaveløsningen skal basere seg på eventuelle standarder og praktiske retningslinjer som foreligger og anbefales. Dette skal skje i nært samarbeid med veiledere og fagansvarlig. For øvrig skal det være et aktivt samspill med veiledere.

Innen tre uker etter at oppgaveteksten er utlevert, skal det leveres en forstudierapport som skal inneholde følgende:

- En analyse av oppgavens problemstillinger.
- En beskrivelse av de arbeidsoppgaver som skal gjennomføres for løsning av oppgaven. Denne beskrivelsen skal munne ut i en klar definisjon av arbeidsoppgavenes innhold og omfang.
- En tidsplan for fremdriften av prosjektet. Planen skal utformes som et Gantt-skjema med angivelse av de enkelte arbeidsoppgavenes terminer, samt med angivelse av milepæler i arbeidet.

Forstudierapporten er en del av oppgavebesvarelsen og skal innarbeides i denne. Det samme skal senere fremdrifts- og avviksrapporter. Ved bedømmelsen av arbeidet legges det vekt på at gjennomføringen er godt dokumentert.

Besvarelsen redigeres mest mulig som en forskningsrapport med et sammendrag både på norsk og engelsk, konklusjon, litteraturliste, innholdsfortegnelse etc. Ved utarbeidelsen av teksten skal kandidaten legge vekt på å gjøre teksten oversiktlig og velskrevet. Med henblikk på lesning av besvarelsen er det viktig at de nødvendige henvisninger for korresponderende steder i tekst, tabeller og figurer anføres på begge steder. Ved bedømmelsen legges det stor vekt på at resultatene er grundig bearbeidet, at de oppstilles tabellarisk og/eller grafisk på en oversiktlig måte og diskuteres utførlig.

Materiell som er utviklet i forbindelse med oppgaven, så som programvare eller fysisk utstyr er en del av besvarelsen. Dokumentasjon for korrekt bruk av dette skal så langt som mulig også vedlegges besvarelsen.

Eventuelle reiseutgifter, kopierings- og telefonutgifter må bære av studenten selv med mindre andre avtaler foreligger.

Hvis kandidaten under arbeidet med oppgaven støter på vanskeligheter, som ikke var forutsett ved oppgavens utforming og som eventuelt vil kunne kreve endringer i eller utelatelse av enkelte spørsmål fra oppgaven, skal dette straks tas opp med instituttet.

Oppgaveteksten skal vedlegges besvarelsen og plasseres umiddelbart etter tittelsiden.

Innleveringsfrist: 10. juni 2014.

Besvarelsen skal innleveres i 1 elektronisk eksemplar (pdf-format) og 2 eksemplar (innbundet), ref. rutinebeskrivelse i DAIM. Det vises til <http://www.ntnu.no/ivt/master-siv-ing> for ytterligere informasjon om DAIM, uttak, kontrakt, gjennomføring og innlevering.

Ansvarlig faglærer / hovedveileder:

Olav Egeland
E-post: olav.egeland@ntnu.no
Telefon: 73597112

Veileder(e) ved NTNU:

Sigbjørn Sangesland
E-post: sigbjorn.sangesland@ntnu.no
Telefon: 91897308

**INSTITUTT FOR PRODUKSJONS-
OG KVALITETSTEKNIKK**



Per Schjølberg
førsteamanuensis/instituttleder



Olav Egeland
Ansvarlig faglærer

Summary

When the production from a well is no longer profitable, the options are to either permanently plug and abandon (P&A) the well, or to re-use the slot by plugging the original well and sidetrack a new wellbore (slot recovery). The purpose of P&A is to establish permanent barriers to prevent migration of hydrocarbons to the surface, in a safe and cost-effective manner. In the coming years, there is an expectation of a significant increase in subsea wells needed to be plugged and abandon. With today's time consuming and expensive P&A operations, the industry desire new innovative methods able to reduce time and cost.

The industry has today a large focus on technology that enables performing the plug and abandonment operation by light intervention vessels. In order for that to occur solving key challenges, such as tubing removal is required. The established approach to remove the tubing in subsea wells today is to use a semi-submersible drilling rig.

The main objective for this project has been to investigate alternative methods for tubing removal. After an evaluation, the most promising alternative was the alternative method, tubing expansion with axial cuts. The method works by bisecting the tubing between the tubing couplings, axial cut one part, expand it and then pull the tubing parts together. Based on 12 m length between the couplings the method is able to create 5.5 m window per operation. Performing the operation 6 times creates a window greater than 30 m and thus fulfilling NORSOK D-10 minimum requirements for logged cement. If the logging shows acceptable cement bonding, the secondary plug can be set.

To evaluate whether one, two or four axial cuts are optimal, An FE-analysis was carried out. Results from the analysis suggested two axial cuts with pressure applied by a mechanical tool only to the region around the cut are optimal.

The operational steps and tools necessary to perform the operation have been assessed. By using a single-trip tool, it was estimated that the method would take approximately 21 hours to complete and be economically feasible for well lengths above 1445 m when the alternative is to pull with a semi-submersible drilling rig.

Further work should be investigating the possibility of decreasing the axial cutting operation time. One option is to use two cutters simultaneously. Further, laboratory testing to confirm the FE-analysis and the expansion tool design should be carried out.

Sammendrag

Når brønnproduksjonen ikke lengre er lønnsomt er alternativet enten å permanent plugge og forlate brønnen eller en påfølgende slissegjenvinning. Formålet med å plugge og forlate en brønn er å etablere en permanent barriere for å hindre migrasjon av hydrokarboner til overflaten på en sikker og kostnadseffektiv måte. I de kommende årene er det forventet en stor vekst i antall undervannsbrønner som må bli permanent plugget og forlat. Med dagens tidkrevende og kostbare metoder for å gjennomføre en plugge operasjon er nye innovative løsninger som reduserer tid og kost ønsket av industrien.

Industrien har i dag et høyt fokus på løsninger som kan gjøre plugge operasjoner mulig ved hjelp av lette intervensjonsfartøy. utfordringer for å muliggjøre bruken av lette intervensjonsfartøy har blitt identifisert hvor trekking av tubing har blitt sett på som en nøkkelfordring. Tubing blir i dag trukket ved hjelp av en borerigg.

Hovedmålet for dette prosjektet har vært å undersøke alternative metoder for fjerning av tubing. Ulike metodene ble evaluert og metoden med størst potensial var ekspansjon av tubing ved hjelp av aksielle kutt. Metoden fungerer ved å splitte tubing mellom koblingene, aksielt kutte ene delen, ekspandere den og trekke de to tubing delene sammen. Basert på en tubing lengde mellom koblingene på 12 m er det mulig å lage et rom på 5.5 m per operasjon. Ved å utføre operasjonen 6 ganger kan en få et rom på over 30 m som tilfredsstillende kravet i NORSOK D-010 for logget sement. Om loggingen viser akseptabel sementbinding kan pluggen bli satt.

For å evaluere om en, to eller fire aksial kutt er å foretrekke har en FE-analyse blitt utført. Resultatet fra analysen viste at to aksial kutt med påført trykk, av et mekanisk verktøy bare til regionen rundt kuttene er å foretrekke.

Gjennom en FE-analyse har en, to og fire aksial kutt blitt vurdert. Det ble funnet ut at den optimale måten å utføre ekspansjonen på var ved 2 aksielle kutt hvor trykk var påsatt kun i området rundt kuttene istedenfor rundt hele omkretsen.

Nødvendige verktøy og operasjonelle aspekt for å gjennomføre metoden har blitt undersøkt. Ved bruk av et verktøy som kan utføre alle delstegene av operasjonen i en tur har metoden

blitt estimert til å bruke rundt 21 timer og være økonomisk lønnsom når alternativet er å trekke mer 1445 m tubing ved bruk av en borerigg.

Videre arbeid bør være å undersøke muligheten for å redusere tiden det tar å kutte aksielt. En måte det kan gjøres på er bruk av to kuttere samtidig. Labratorium testing for å bekrefte FE-analysen og designet på ekspansjonsverktøyet bør også bli gjort.

Preface

This master thesis was written during the spring semester of 2014 as a part of a two-year Master program in Subsea Technology, at the Department of Production and Quality Engineering, at the Norwegian University of Science and Technology (NTNU).

I would like thank my supervisor Professor Sigbjørn Sangesland at the Department of Petroleum Engineering and Applied Geophysics, for much appreciated guidance along the way. I would also like to thank PhD candidate Jesus Alberto De Andrade Correia for his help with the FEA.

Table of Contents

SUMMARY	VII
SAMMENDRAG	IX
PREFACE.....	XI
LIST OF FIGURES.....	XV
LIST OF TABLES	XVII
ABBREVIATIONS	XIX
NOMENCLATURE.....	XXI
1 INTRODUCTION.....	1
1.1 OBJECTIVES	2
1.2 LIMITATIONS.....	2
1.3 STRUCTURE OF THE REPORT	2
2 WELL DESIGN	5
2.1 STANDARDIZATION OF CASING AND TUBULARS	7
3 RULES AND REGULATIONS FOR PLUG & ABANDONMENT	11
3.1 WELL BARRIER	11
3.2 PERMANENT PLUG AND ABANDONMENT.....	11
3.3 UNITS TO PERFORM PLUG AND ABANDONMENT	13
3.3.1 <i>Category A – Light well intervention</i>	14
3.4 PERMANENT PLUG AND ABANDONMENT OPERATION	14
3.5 EXISTING PLUG AND ABANDONMENT METHODS.....	15
3.5.1 <i>Section Milling</i>	16
3.5.2 <i>Cut and Pull</i>	17
3.5.3 <i>Perforate, Wash and Cement</i>	17
3.6 RIGLESS PLUG AND ABANDONMENT	18
4 ALTERNATIVE METHODS FOR TUBING REMOVAL.....	21
4.1 ACCELERATED CORROSION	21
4.2 CRUSHING THE TUBING DOWNWARDS	22
4.3 PULL TUBING 30 M.....	23
4.4 SEGMENT CUTTING	24
4.5 TUBING EXPANSION WITH AXIAL CUTS	25
4.6 TUBING EXPANSION BY EXPLOSIVES.....	26
4.7 DISCUSSION OF ALTERNATIVE METHODS FOR TUBING REMOVAL.....	28
5 TUBING EXPANSION WITH AXIAL CUTS	31

5.1	FINITE ELEMENT ANALYSIS.....	34
5.1.1	<i>Scope of the Analysis</i>	34
5.1.2	<i>Model set up</i>	35
5.1.3	<i>Results</i>	44
5.1.4	<i>Intermediate FEA Discussion</i>	47
5.2	OPERATIONAL ASPECTS.....	49
5.2.1	<i>Methods for Cutting Tubing</i>	49
5.2.2	<i>Intermediate Discussion</i>	53
5.2.3	<i>Expansion Tool</i>	54
5.2.4	<i>Pull Tubing Tool</i>	56
5.2.5	<i>Single Trip Tool</i>	58
5.2.6	<i>Operational Steps</i>	59
5.3	TIME AND COST ESTIMATION	65
5.4	DISCUSSION.....	67
6	CONCLUSION	71
6.1	FURTHER WORK.....	71
	REFERENCES	73
APPENDIX A:	TUBING STRESS EXPANSION	79
APPENDIX B:	FORCE REQUIRED TO DISPLACE TUBING	83
APPENDIX C:	FEA - PLASTIC DEFORMATION APPROACH	85
APPENDIX D:	FEA – PRESSURE FITTING APPROACH	91
APPENDIX E:	PARAMETERS FOR AWSJ	93
APPENDIX F:	CYLINDER PRESSURE	97
APPENDIX G:	SINGLE TRIP TOOL - HYDRAULIC SCHEMATIC	99

List of Figures

Figure 2-1: Typical well design 6

Figure 2-2: API Connectors 9

Figure 3-1: Well Barrier 12

Figure 3-2: Categorization of vessels 13

Figure 3-3: Phases in a plug and abandonment operation..... 15

Figure 3-4: HydraWash, Perforate, wash and cement technique 17

Figure 4-1: Acid to remove the tubing. 22

Figure 4-2: Pushing the tubing downwards by crushing it..... 23

Figure 4-3: Jack mechanism and volume controlled connected to the SSD 24

Figure 4-4: Segment cutting. 25

Figure 4-5: the basic steps for the tubing expansion with axial cuts method..... 26

Figure 4-6: Tubing expansion by using explosives..... 27

Figure 5-1: Illustration of scope of the analysis. 35

Figure 5-2: Model 1 – Tubing with one radial cut. 37

Figure 5-3: Model 2 – Tubing with two radial cuts. 37

Figure 5-4: Model 3 – Tubing with four radial cuts..... 37

Figure 5-5: Global coordinate system. 38

Figure 5-6: Mesh casing and tubing. 39

Figure 5-7: Mesh at cut end region. 39

Figure 5-8: Mesh tubing start of cut..... 40

Figure 5-9: Contact setup between the tubing and casing..... 41

Figure 5-10: Pressure applied in steps..... 43

Figure 5-11: Pressure distribution. 43

Figure 5-12: Pressure distribution on Model 2c..... 44

Figure 5-13: Probe placement. 45

Figure 5-14: Plastic deformation on the tubing..... 45

Figure 5-15: Deformation on the tubing. 46

Figure 5-16: Total applied force vs deformation output. 47

Figure 5-17: Process parameters influencing the abrasive water jetting process..... 50

Figure 5-18: Pressure loss due to friction as a function of tubing diameter..... 51

Figure 5-19: Cut performed by a chemical cutter 51

Figure 5-20: Explosive Cutting tool and a pipe end after cutting. 52

Figure 5-21: Electric-Mechanical cutters.....	52
Figure 5-22: Inflatable packer used for zonal isolation	55
Figure 5-23: Typical pipe expander tool.....	55
Figure 5-24: Side view - Tubing expansion tool.....	56
Figure 5-25: Top view – Tubing expansion tool.....	56
Figure 5-26: Pull Tubing Tool	57
Figure 5-27: single trip tool.....	59
Figure 5-28: Operation procedure.....	60
Figure 5-29: Procedure step one: axial cutter.....	61
Figure 5-30: Procedure step one: after axial cuts.....	61
Figure 5-31: Procedure step two: radial cut.....	62
Figure 5-32: Procedure step three, tubing expansion.....	63
Figure 5-33: Procedure step four, Pull tubing.....	64

List of Tables

Table 2-1: Grades of Casing recognized by the API..... 7

Table 2-2: Casing range lengths 8

Table 3-1: summary of the main differences between category A, A+ and A++ 14

Table 4-1: Evaluation of alternative methods. 29

Table 5-1: Material Hardening Index 32

Table 5-2: Material properties 36

Table 5-3: Model dimensions 36

Table 5-4: Element sizes used. 39

Table 5-5: Points with high plastic deformation. 46

Abbreviations

API	American Petroleum Institute
AWSJ	Abrasive Water Suspension Jet
BCSG	Buttress Threads and Couplings
BHA	Bottom Hole Assembly
BOP	Blowout Preventer
CAT	Cementing Adaptor Tool
CSG	Short Round Thread and Couplings
DOF	Degree Of Freedom
DHPU	Downhole Hydraulic Power Unit
ECD	Equivalent Circulation Density
FE	Finite Element
FEA	Finite Element Analysis
HPU	Hydraulic Power Unit
HSE	Health, Safety and Environment
ID	Inner Diameter
IJ	Integral Joint tubing
IMR	Inspection, Maintenance & Repair
IRS	Intervention Riser System
LCSG	Long Round Threads and Coupling
LWI	Light Well Intervention
LWIV	Light Well Intervention Vessel
N.C.S	Norwegian Continental Shelf
OD	Outer Diameter
P&A	Plug and Abandonment
PP&A	Permanent Plug and Abandonment
PE	Polyethylene
PSA	Petroleum Safety Authority
PSV	Platform Supply Vessel
PWC	Perforate, Wash and Cement
Rpm	Revolutions per minute
SF	Completed coupling with Special end-Finish
SIL	Subsea Intervention Lubricator

SSD	Subsea Shutoff Device
TCP	Tubing-Conveyed Perforating
WBE	Well Barrier Elements
XCSG	Extreme-line threads

Nomenclature

Symbol	Description	Unit
C	Circumference	mm
D	Diameter	mm
E	Young's Modulus	N/mm^2
F	Force	N
F_{normal}	Contact Force	N
f	Friction Factor	-
h	Height	mm
I	Moment of Inertia	mm^4
k_{normal}	Contact Stiffness	-
k_s	Equivalent sand grain roughness	μm
l	Length	mm
p	Pressure	MPa
R	Radius	mm
Re	Reynolds number	-
u_s	Surface structure uniformity factor	-
v_{max}	Max Deflection	mm
v	Velocity	m/s
$x_{penetration}$	Penetration	mm
δ_{max}	Max Achievable Expansion Ratio	-
ρ	Density	kg/m^3
σ_H	Hoop Stress	MPa
σ_L	Longitudinal Stress	MPa
σ_r	Radial Stress	MPa
ν	Poisson's Ratio	-

1 Introduction

When the production from a well is no longer profitable, the options are to either permanently plug and abandon the well, or to re-use the slot by plugging the original well and sidetrack a new wellbore (slot recovery). The purpose of P&A is to establish permanent barriers to prevent migration of hydrocarbons to the surface, in a safe and cost-effective manner. On the Norwegian continental shelf (N.C.S) 3733 development wells (production, injection & monitoring), have been drilled between 1966 and May 2013. Over the last 10 years, the average of new development wells has been 144 new wells per year [1]. Exact number of wells needed to be plugged and abandoned in the coming years is unknown, but Statoil has proclaimed they are planning to plug roughly 1000 wells during the next 25 years [2]. With today's technology plugging and abandonment of a well takes between 20 and 60 days [1], and to meet the demand for plug and abandonment operation, a large amount of rigs needs to be set aside for the task. With average day rates for semi-submersible drilling rigs at \$426,000 [3] the demand for new cost-effective solutions for P&A operations are increasing.

The current trend to reduce cost is new innovative solutions that deployed from vessels instead of drilling rigs. By using vessels for P&A work, more drilling rigs can perform tasks such, as increasing oil recovery and exploration. With a large difference in daily cost between drilling rigs and vessels, the potential to reduce cost is presence. However, performing a P&A operation from a vessel is not without technological challenges and the main issues or reason of concern to perform P&A operations from vessels are:

- Securing good cement behind casing
- Plugging of wells with control lines
- Need for pulling tubular and equipment
- Need for section milling
- Operations without riser

New methods related to tubing removal may solve some of these issues and enable more P&A work from vessels.

1.1 Objectives

The overall objective of this thesis is to present alternative methods for tubing removal with intends to set the secondary plug without having to pull the tubing. Different methods will be evaluated and the most promising alternative will be investigated further. The investigation will consist of a finite element analysis, operational aspects by looking at tool design and procedures, and a time and cost estimation. To meet the overall objective the following objectives are treated:

1. Describe typical design on the Norwegian continental shelf and requirement for permanent plug and abandonment.
2. Propose and evaluate alternative methods for tubing removal. Analyze the most promising alternative.
3. Estimate potential cost savings by implementing the alternative by comparing it to current methods.

1.2 Limitations

The thesis is limited to tubing removal with intend to create a large enough window downhole to use traditional logging equipment. The goal is to propose a method able to create a window of 30 m to comply with the minimum requirements of NORSOK D-10 before the cement behind the casing can be logged and verified and the secondary plug can be set. The effect the alternative method has on other parts of the plug and abandonment operation, challenges related to logging, cementing and control lines will not be looked upon.

1.3 Structure of the Report

The rest of the thesis is structured as follows. Chapter 2 presents typical well design and API standards for casing and other tubular goods that are used, but not limited to, the Norwegian continental shelf (N.C.S) and casing connectors. In Chapter 3, rules and regulations for plug & abandonment is presented. The chapter includes current methods to perform a permanent plug and abandonment operation and challenges related to rigless plug and abandonment. In Chapter 4, alternative methods for tubing removal is presented and evaluated. Chapter 5 presents the most promising alternative method, tubing expansion with axial cuts. The chapter includes a finite element analysis performed on the tubing expansion, operational aspects,

such as tool design and procedure related to the alternative method and time and cost estimation. In the last chapter, chapter 6, the conclusion of the thesis and recommendations for further work is presented.

2 Well Design

At a certain stage during the drilling of oil and gas wells, it becomes necessary to line the walls of the borehole with a steel pipe, called casing. Casing serves several important functions during the drilling and production the well these include [4]:

- Preventing the wellbore from collapsing, for example by caving of the hole.
- Serving as a high strength flow conduit to surface for both drilling and production fluids.
- Isolating the wellbore fluids from the subsurface formation, minimizing the damage from the drilling process.
- Provide support for weak or fractured formations from mud weights, which may cause these zones to break down.
- Provide a suitable support for wellheads and blowout prevention equipment.

To seal of troublesome zones such as high-pressured zones, weak and fractured formations, unconsolidated formations and sloughing shales and drill to the total depth, the wells are drilled and cased in several steps. Different casing sizes are required for different depths. Five different casings is used to complete a well; conductor, surface casing, intermediate casing, production casing and reservoir liner [5], illustrated on Figure 2-1. Conductor casing is the first casing string to be run and has consequently the largest diameter. The conductor is in most instances set soon after drilling has commenced to keep unconsolidated seabed formation from out of the hole. The conductor also provides a conduit for the mud returns [6]. After the conductor is set, the borehole is drilled to below the freshwater source and the surface casing is installed and cemented. The main purpose of the surface casing is to seal off any fresh water zones and structural support for the remaining casing strings and wellhead equipment. It also provides some minimal pressure integrity which may enable a diverter or a blowout preventer (BOP) to be attached to the top of the surface casing [7]. The intermediate casing is set after the surface casing. The purpose of the intermediate casing is to protect against caving of weak- or abnormally-pressured formation. Several strings of intermediate casing may be required depending upon the number of problems encountered. If rock formations are stable, drilling can be undertaken for a relatively long period prior to the setting of casing. The depth the casing is set on depends on knowledge of pore pressure and fracture gradients. [8]

The production casing is often the last string of casing to be run. It is either run through the reservoir or set just above the reservoir (open hole completion). The main purpose of the production casing is to isolate the production from other formations and protect the completion tubing [9]. The reservoir liner is a short string of casing that does not extend back to the surface. The reservoir liner is usually set across the reservoir interval. The liner is run back inside the previous casing string to provide some overlap. The liner is used to reduce the cost of well completing and add some flexibility in the completion design in terms of increasing the diameter of the conduit and components when the fluid characteristics make it beneficial [10].

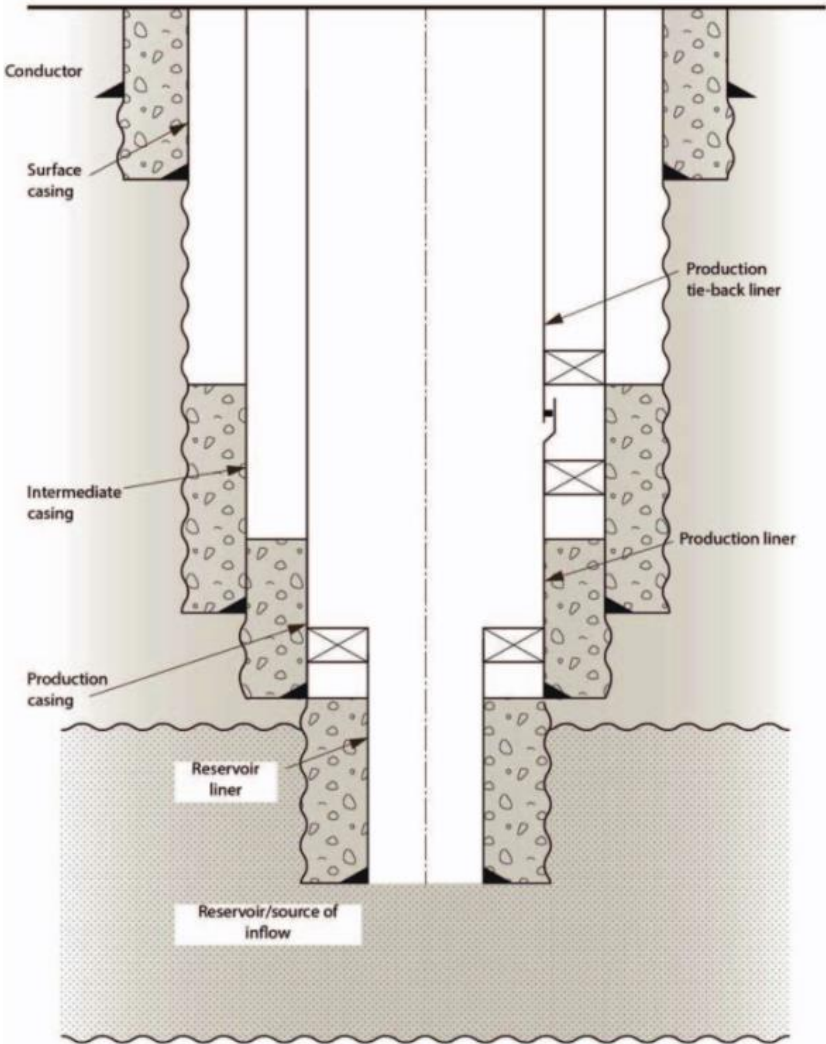

Figure 2-1: Typical well design [5].

2.1 Standardization of casing and tubulars

The American Petroleum Inst. (API) has developed standards for casing and other tubular goods that being used, but not limited to, the Norwegian continental shelf (N.C.S). A Casing is defined as a tubular pipe with a range of outer diameters (OD) between 4.5 and 20 inch. Besides OD, API classifies the casing by wall thickness, material grade, thread and coupling type, length (range) and nominal weight.

The strength characteristics of the casing are defined by the material grade. API has defined the different grades by assigning a unique letter followed by a number. The number represents the minimum yield strength of the steel in kpsi. The most common API steel grades and their respectively strength characteristics can be found in Table 2-1.

Table 2-1: Grades of Casing recognized by the API [4].

API Grade	Yield strength (MPa)		Minimum Ultimate Tensile Strength (MPa)	Minimum Elongation (%)
	Minimum	Maximum		
H-40	275.8	551.6	413.7	29.5
J-55	379.2	551.6	517.1	24.0
K-55	379.2	551.6	655.0	19.5
C-75	517.1	620.5	655.0	19.5
L-80	551.6	655.0	655.0	19.6
N-80	551.6	758.4	689.5	18.5
C-90	620.5	723.9	689.5	18.5
C-95	655.0	758.4	723.9	18.0
P-110	758.4	965.3	861.8	15.0

The API standards recognize three length ranges for casing; Range 1 (R-1), Range 2 (R-2) and Range 3 (R-3). The various range lengths are listed in Table 2-2. The casing length is most often run in R-3 to reduce the number of connections in the string [4].

Table 2-2: Casing range lengths [11].

	Range 1 (m)	Range 2 (m)	Range 3(m)
Casing	4.88 – 7.62	7.62 – 10.36	10.36 – 14.63
Threaded and coupled tubing and casing used as tubing	6.10 – 7.32	8.53 – 9.75	11.58 – 12.80
Integral tubing connections (including IJ/PE and IJ/SF)	6.10 – 7.92	8.53 – 10.36	11.58 – 13.72

To connect the individual joints of casings threaded connection is used. API 5CT states that the couplings shall be seamless, be of the same grade and type as the casing and be given the same heat treatment as the casing. There are four types of casing connectors defined by the API standards:

- Short round thread and couplings (CSG)
- Long round threads and coupling (LCSG)
- Buttress threads and couplings (BCSG)
- Extreme-line threads (XCSG)

All casing connectors except XCSG are based on the use of a coupling, illustrated on Figure 2-2. For each of the other types, the connection is made by screwing the threaded pipe end into a similar threaded coupling. CSG and LCSG (Figure 2-2a) have the same basic design with rounded shaped threads. The longer threads in LCSG provide greater strength when needed. The coupling type is very commonly used in wells without high requirements to high pressure gas- and solid-free, low-viscosity liquid sealing because of its proven reliability, ease to manufacture and low cost. The BCSG connector (Figure 2-2b) has square shaped threads reducing the unzipping tendency and making the joint efficiency of the connector high. The BCSG connector is however not a good choice when a leak-proof connection is needed.

The XCSG connector is an integral joint providing a significantly lower OD compared to the other connectors, and thus providing an alternative when the largest possible casing size is run

in a restricted clearance situation. The connection cost however much more than the other connectors due to it require thicker pipe walls near the ends and lower machining tolerance is needed for the metal-to-metal seal. [4]

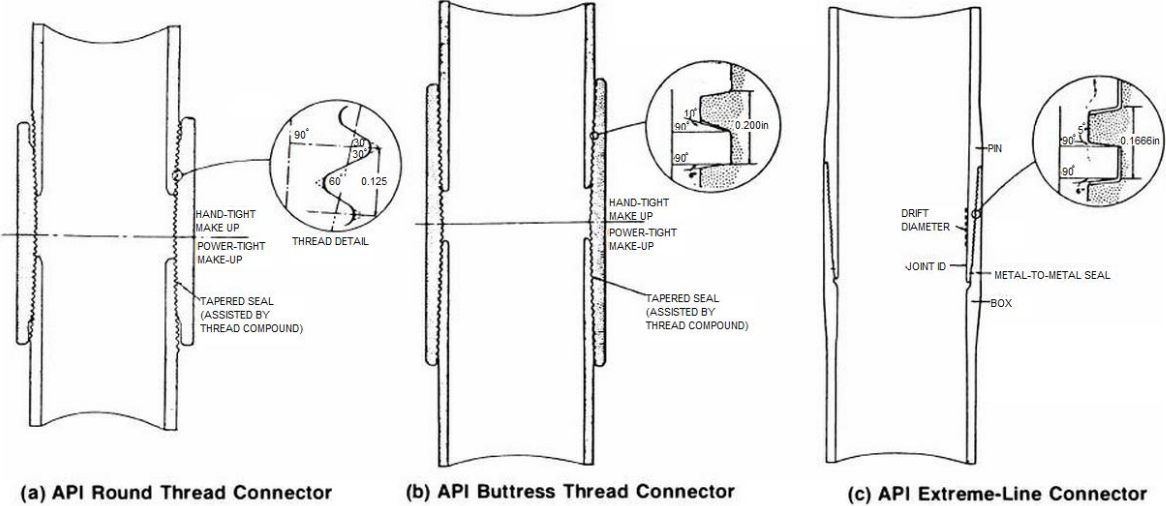

Figure 2-2: API Connectors [4].

3 Rules and Regulations for Plug & Abandonment

Plug and abandonment of wells on the Norwegian Continental Shelf (N.C.S) are governed by the activities issued by the Petroleum Safety Authority Norway (PSA Norway). Their regulations state that NORSOK D-010 shall be used as the minimum requirements for well design, planning and execution of well activities and operations. The main objectives for well abandonment procedures are:

- Prevent Hydrocarbon migration and leakage to surface
- Prevent communication between layers containing hydrocarbons
- Prevent contaminating aquifers
- Prevent pressure breakdown of shallow formations
- Remove any hazards that protrude the seabed
- Design the well initially with consideration to final abandonment

3.1 Well Barrier

A well barrier is in NORSOK D-010 defined as *“Envelope of one or several well barrier elements preventing fluids from flowing unintentionally from the formation into the wellbore, into another formation or to the external environment.”* The NORSOK standard defines two types of well barriers; Primary- and secondary well barriers. The primary well barrier is defined as *“first well barrier that prevents flow from a potential source of inflow”* while the secondary well barrier is defined as *“second well barrier that prevents flow from a potential source of inflow”*.

The NORSOK standard states that the well barriers shall be defined prior to commencement of an activity or operation by identifying the required well barrier elements (WBE) to be in place, their specific acceptance criteria and monitoring method. When the source of inflow are Hydrocarbon bearing formations or when there is an abnormally pressured formation with potential to flow to the surface there must be a minimum of two independent well barriers.

3.2 Permanent Plug and Abandonment

Permanent abandonment is in NORSOK D-010 defined as *“well status, where the well is abandoned permanently and will not be used or re-entered again.”* Since permanently

abandoned wells are plugged with an eternal perspective, the principle of two well barriers is not sufficient. It also requires well barriers to prevent crossflow between the formations and permanently isolate flow conduits from exposed formation(s) to surface after casing(s) are cut and retrieved. To recognize a well barrier as permanent it must extend across the full cross section of the well, including all annuli and sealing both vertically and horizontally, illustrated on Figure 3-1. The well barrier(s) is placed adjacent to an impermeable formation with sufficient formation integrity for the maximum anticipated pressure.

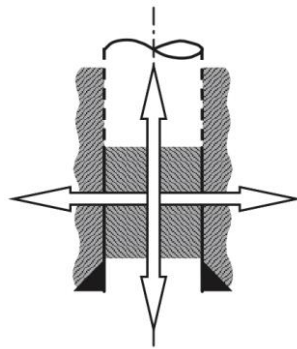

Figure 3-1: Well Barrier [5]

For PP&A the WBE are categorized into external- and internal WBE. The external WBE (e.g. casing cement) needs to be verified to ensure a vertical and horizontal seal. The requirement for the external WBE is 50 m with formation integrity at the base of the interval. If the casing cement is verified by logging, a minimum of 30 m interval with acceptable bonding is required. The internal WBE (for example a cement plug) needs to be positioned over the entire interval where there is a verified external WBE and needs to be minimum 50 m if set on a mechanical plug/cement as a foundation.

NORSOK D-010 states that a permanent well barrier should have the following characteristics:

- a) Provide long term integrity (eternal perspective)
- b) Impermeable
- c) Non-shrinking
- d) Able to withstand mechanical loads/impact
- e) Resistant to chemicals/ substances (H_2S , CO_2 and hydrocarbons)
- f) Ensure bonding to steel
- g) Not harmful to the steel tubulars integrity

3.3 Units to Perform Plug and Abandonment

Three main categories based on complexity is used to categorize units to perform intervention tasks, illustrated on Figure 3-2. The categorized groups and their meaning are [12]:

- Category A: Mono-hull vessel for light well intervention. Typical tasks include wireline operations, pull and set plugs, well monitoring, well diagnostics and perforating/re-perforating. [13]
- Category B: fit for purpose rig optimized to perform all operations required with subsea wells. Used in wireline operations, coiled tubing, plugging of wells and sidetrack drilling. [14]
- Category C: Ordinary drilling rigs used for all types of operations. [14]

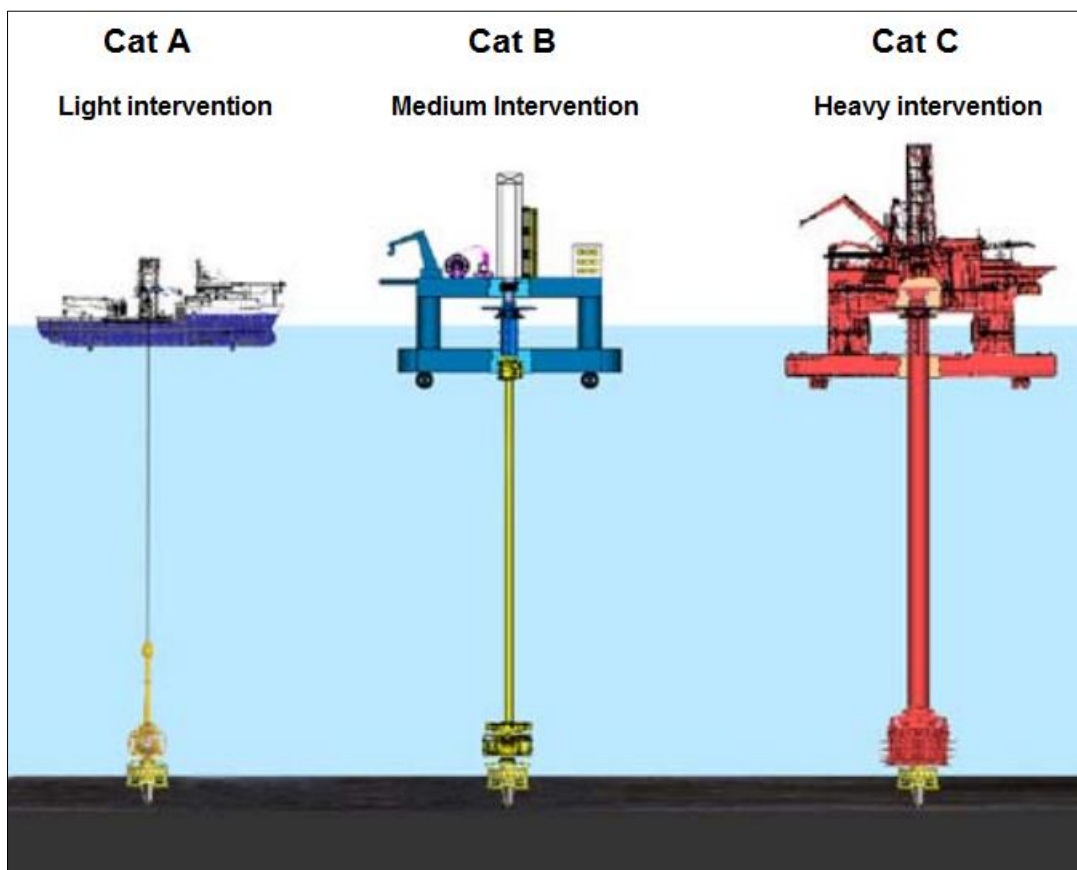

Figure 3-2: Categorization of vessels [12].

3.3.1 Category A – Light well intervention

Light intervention tasks is defined as maintenance operations performed within the flow conduit inside the production string, performed by for example equipment deployed by wireline. The units performing light intervention tasks in category A is further divided from smaller to largest into category A, Category A+ and Category A++ [15].

Category A: is only able to perform wireline operations performed via a subsea intervention lubricator (SIL). The vessel is typically a mono-hull due to build cost and transit speed.

Category A+: is able to perform wireline and coiled tubing deployed via SIL or 7 in. riser, but unable to work the full 7 in. bore.

Category A++: performs wireline operations and has full-bore capability with coiled tubing through the 7 in. riser.

The difference between the categories is summarized in Table 3-1.

Table 3-1: summary of the main differences between category A, A+ and A++ [15].

	Category A	Category A+	Category A++
Intervention system	SIL	SIL/IRS	IRS
Wireline operation	yes	yes	yes
Riser	no	<7 in.	<7 in.
Coiled tubing	no	yes	yes

3.4 Permanent Plug and Abandonment Operation

Three main phases used to describe a PP&A operation is illustrated on Figure 3-3 [16]. The three phases and their meaning are:

- Phase 1: The wellhead is checked, waste handling is prepared, wireline investigation is performed and the primary reservoir plug is set
- Phase 2: The secondary- and open hole to surface plug are installed
- Phase 3: The conductor and surface casing is cut and pulled from 5 m below the seabed

Today, Phase 1 can be performed by LWI vessels, if the well diagnostics performed indicates sufficient tubing integrity. To install the reservoir plug and overcome the reservoir pressure,

wireline rig-up pumping cement down the well is used (bullheading) [17]. A semi-submersible rig normally performs phase 2. The tubing is pulled, and if the logging does not show good cement behind the casing, part of the casing is either cut and pulled or section milled to set the plugs [18]. Similar to phase 1, phase 3 can be performed by a LWI vessel. A tool consisting of a wellhead connector and a cutting nozzle on a stinger is used. To perform the cutting operation abrasive water jetting with pressurized water between 60 and 120 MPa and abrasive particles is used [19].

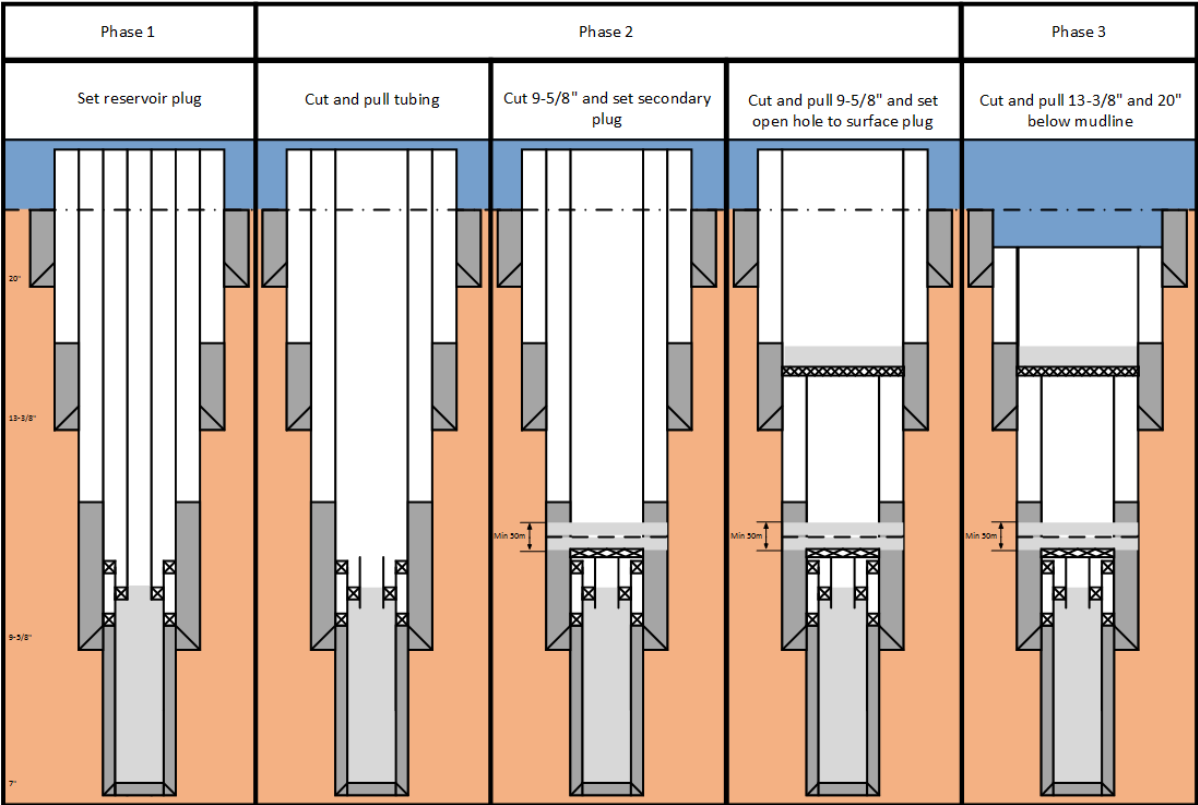

Figure 3-3: Phases in a plug and abandonment operation.

3.5 Existing Plug and Abandonment Methods

The main methods to perform a P&A operations with poor cement today are:

- Section milling
- Cut and pull
- Perforate, wash and cement

3.5.1 Section Milling

When a well is abandoned, plugs sealing the wellbore in all directions, including all annuli has to be placed. To meet the requirements stated in NORSOK D-010, communication from the wellbore to the annulus is needed. Normally this is done with the section milling technique illustrated in Figure 3-1. The technique consists of a tool that has multiple “knives” made out of tungsten carbide located on pivots. With force applied from a hydraulic actuated cone, knives mill through the casing wall and are locked in outer position. Weight is then applied from the surface to mill down the desired interval of the casing [20]. After the milling operation, steel cuttings (swarf) generated from the milling is cleaned out. An underream is then used to clean and expose the formation in the section before it can be cemented [5].

There are several challenges related to this technique. A drill string that exhibits substantial axial, lateral and torsional movement rotates the downhole mill. The downhole cutter must therefore be strong enough to survive the impact energy associated with the drill string motion, yet sharp enough to effectively cut the tubing [20]. It must also have a milling fluid with sufficient weight to keep the open hole stable and viscosity to transport the swarf and debris to surface. The required fluid viscosity profile required can generate an Equivalent Circulation Density (ECD) exceeding the fracture gradient of the exposed open hole. Therefore, losses while circulating, swabbing, well control, poor hole cleaning and packing off the Bottom Hole Assembly (BHA) can be expected. Health, Safety and Environmental (HSE) challenges are also present during handling and disposal of the generated swarf and debris. The swarf has sharp angular surfaces and personal protective equipment to protect hands and eyes must be worn [21].

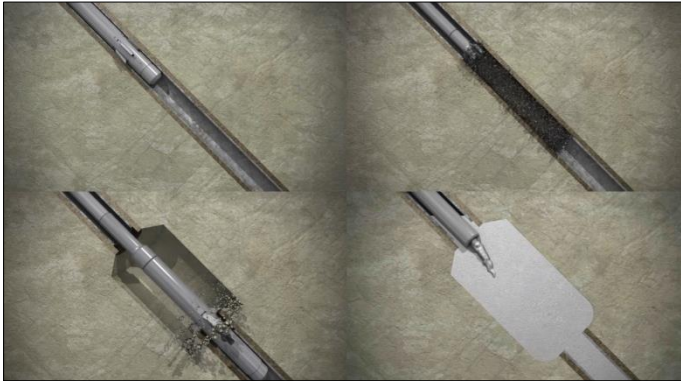

Figure 3-1: The four steps in the milling section technique, from left top corner: Milling, cleaning, underream and cementing [9].

3.5.2 Cut and Pull

An alternative to the section milling technique is to cut and pull the casings. First cutting the casing right above the point where annulus is uncemented and then pulling the section out of the well does the method. To find top of cement, logging tools or a stretch test is performed. The cemented casing section may be challenging to remove in one part, and it may have to be removed in several cut and pulls. Depending on bonding strength and cemented casing length, the operation can be time consuming and costly [22].

3.5.3 Perforate, Wash and Cement

Another option that newly has been developed by HydraWell Intervention is the Perforate, Wash and Cement technique (PWC). The new approach is a system perforating un-cemented casing, washes the annular space and then mechanically placing the cement across the wellbore cross-section in a single run. The benefit of using the PWC approach is cost reduction due to saving time [21]. With the PWC approach, the verification of the annulus plug quality is done by drilling out the plug and logging the annulus cement. By comparing the pre- and post-logs an assessment of the plug quality can be done. The internal casing plug can then be replaced to regain cross sectional plug integrity. [21]

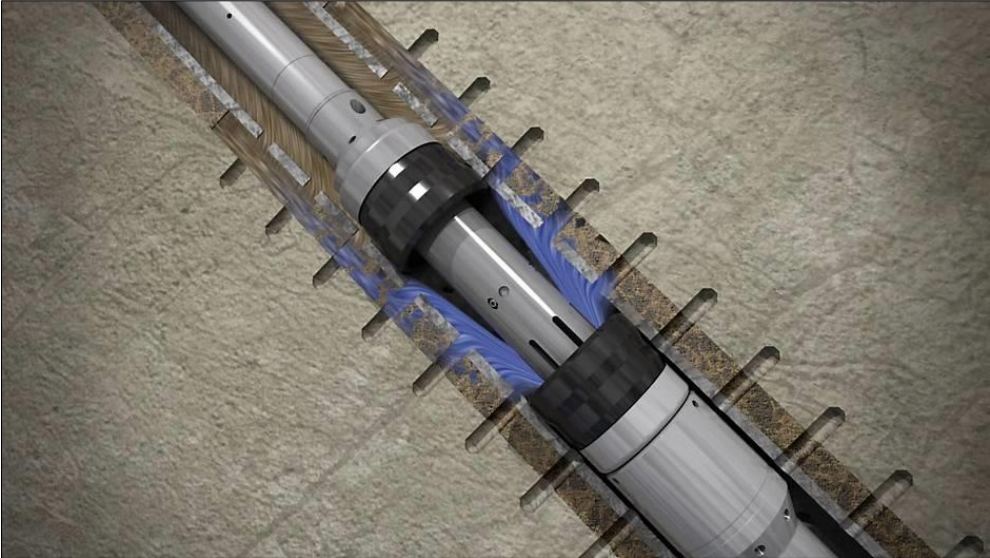

Figure 3-4: HydraWash, Perforate, wash and cement technique [23].

3.6 Rigless Plug and Abandonment

Plug and abandonment is an operation that does not provide any income. With a large amount of wells needed to be plugged in the coming years, the industry has in the past years been looking for solutions to reduce the use of drilling rigs for P&A operations, due to the high cost and limited availability of drilling rigs. It is expected that the use of mono-hull vessels or specially designed vessels will in the future be used for P&A work, due to large potential cost saving. It has been estimated that the potential cost saving for plugging a well with use of a vessel compared to the use of a rig is in the area of 70% of total cost, if the efficiency can be matched [24]. The use of Light intervention vessels (LWIV) is currently being used in larger P&A campaigns where multiple wells are to be plugged and abandoned. Typical work performed by the LWIV can be temporary P&A by killing the well, punch tubing and set temporary plugs and remove X-mas trees before the rig gets on location [25] and complete phase 3 of the P&A operation by removal of casing and wellhead 5 m below seabed [26].

However, there are challenges that need to be solved or overcome before a well can fully be plugged and abandoned on the Norwegian continental shelf. The main technical challenges related to the use of LWIV can be summed up in the following main categories [27]:

1. Securing good cement behind casing

To be in conveyance with the NORSOK D-010 with respect to having well barriers that extends across the full cross section of the well with eternal perspective, the condition of the cement behind the casing in the area where the internal plugs are to be set needs to be known. This may mean that verification must be performed from the vessel and one may have to wait for interpreting results before proceeding with the operation. Logging the cement behind the casing also possesses technical challenges related to the logging tools. The logging tools lack the ability log cement or isolation qualities through multiple tubular. To compensate for this todays practice involve pulling the tubing and casing to log the relevant cement.

2. Plugging of wells with control lines

In wells with deep pressure gauges and sliding sleeves, there are electric, fiber and hydraulic control lines attached to the tubing. These lines may have the potential to constitute micro annuli through the internal bore or through degradation of the plastic encapsulation and thereby potentially a leak path. In scenarios where the control lines

goes through the region where the isolation plugs are to be set, it may be a challenge to be in conveyance with NORSOK D-010 which states that control lines and cables shall not form part of permanent well barriers.

3. Need for pulling tubular and equipment

Operations that requires pulling tubular or equipment out of the well are much more demanding than letting it remain in the well. Pulling the tubing requires large pulling force and a pipe handling system. Environmental and HSE issues for personnel can also be an issue that needs to be handled, if completion with low-radioactive deposits is pulled. Pipe handling systems for mono-hull vessels do exist, but solutions that avoid pulling tubular will be an important basis for the premise of making P&A operations from a vessel.

4. Need for section milling

If the cement behind the casing is inadequate or the condition is not possible to confirm, it may be necessary to mill away a section of the casing in order of achieving a permanent well barrier across the full cross section of the well. Transporting the swarf to the surface without the use of marine risers may be challenge, and a solution where the swarf is left in the well may be an enabler to perform PP&A in wells with poor cement behind the casing.

5. Operations without riser

Running operations with a riser from a vessel is possible, but it is desirable to avoid due to high cost, time consuming to install and requires a large portion of the deck space. To compensate for the lack of a riser, cementing of the well and return of the mud/fluid will have to be made through hoses.

4 Alternative Methods for Tubing Removal

The alternative methods presented in this chapter looks upon solving the challenges related to pulling the tubing. The methods will present ways to set the secondary plug by creating a 30 m window through the tubing and thus making it possible to verify the cement behind the casing by traditional logging equipment. Methods involving the use of a drilling rig will not be looked upon and it is assumed that the reservoir plug has been set. The following method will be presented shortly:

- Accelerated corrosion
- Crushing the tubing downwards
- Pull tubing 30 m
- Segment cutting
- Tubing expansion with axial cuts
- Tubing expansion by explosives

4.1 Accelerated Corrosion

Accelerated corrosion with the use of a highly corrosive acid solution could corrode away carbon steel quickly. SINTEF currently have an ongoing research project with the use of a Hydrogen Chloride (HCL) and Hydrogen Sulfide (H₂S) to corrode the tubing. The result shows that it is possible to corrode most of the casing wall in approximate one day. However, there are some risks and concerns that would need to be solved to use it [28]. The method would require:

- Special equipment that can withstand the corrosive acid
- A method to flush out the acid and iron particles afterwards
- Procedures to make sure the acid do not react with other equipment
- Storage solution to store safely large amount of acid

Concept procedure, illustrated on Figure 4-1:

1. Punch tubing and install a mechanical plug. The mechanical plug would have to be in a material with high acid resistance
2. Fill the casing with the acid solution or circulate the acid from topside
3. Flush out the acid and iron particles
4. Run a cutting tool to remove the remaining tubing wall
5. Log the cement behind the casing
6. If cement is good, set secondary plug

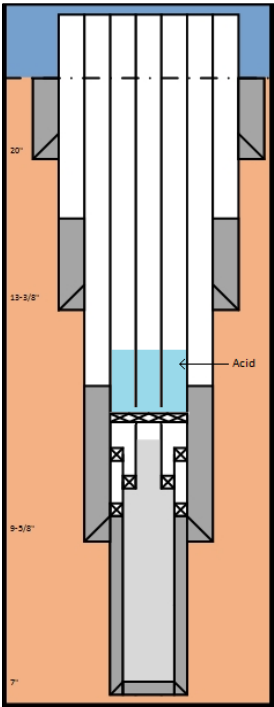

Figure 4-1: Acid to remove the tubing.

4.2 Crushing the Tubing Downwards

Crushing the tubing downwards is an alternative approach developed by Oilfield Innovations Ltd. The company has patented a solution where they first cut the tubing string vertically and then crush it downwards by using a hydraulic piston, illustrated on Figure 4-2. The solution could be improved by making weak spots in the casing with a vertical abrasive cutter. The weak points would reduce the required force required to cause the tubing to collapse. However, it is questionable how feasible the technology is.

Concept procedure:

1. Cut a window in the tubing large enough to fit the piston
2. Cut weak spots in the tubing
3. Crush tubing
4. Log cement behind the casing
5. If cement is good, set secondary plug

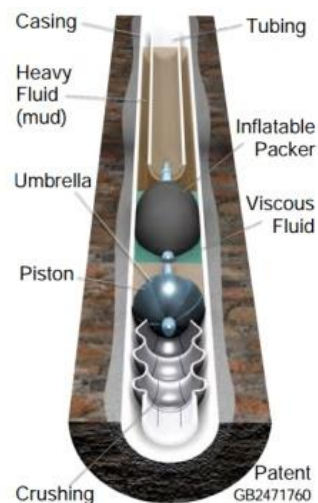

Figure 4-2: Pushing the tubing downwards by crushing it [29].

4.3 Pull Tubing 30 m

Pulling the tubing 30 m alternative consists of using a subsea jack mechanism able to pull the tubing. The idea is to pull the necessary 30 m and leave rest of the tubing downhole. When the tubing is pulled 30 m it would be locked in place by a locking tool to prevent axial movement. The basic idea is simple, but issues in regards to fulfilling the requirement of minimum two barriers at all stages, locking the tubing after it has been pulled without hinder tools to be deployed and environmental challenges would have to be solved. Fulfilling the requirements of having minimum two barriers may be done by installing a subsea shutoff device (SSD). The SSD is designed to meet the requirements to be able to shear, seal and control the well in the event of an incident without the use of a blowout preventer (BOP). The SSD is equipped with a wellhead connector profile, which enables other equipment to be connected [30]. Figure 4-3 shows a principle sketch of a subsea jack mechanism connected to a SSD and a volume control system.

Concept procedure:

1. Install Subsea Shutoff device (SSD)
2. Cut tubing downhole
3. Install Subsea jack mechanism
4. Pull tubing 30 m
5. Lock tubing
6. Log casing cement
7. If cement is good, set secondary plug

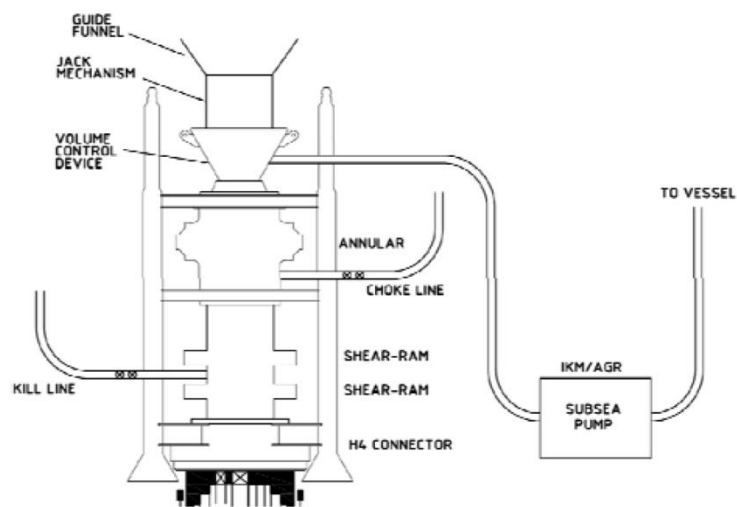

Figure 4-3: Jack mechanism and volume controlled connected to the SSD [30].

4.4 Segment Cutting

The alternative is to bisect the tubing between the connectors and then on lower part cut out two segments large enough for the other part to fit into, as illustrated on Figure 4-4. Cutting the bottom tubing part and lower the top part into it with enough offset may create a window equal to the segment length and by repeating the process a couple of times, a 30 m window would be created. Any cutting tool could perform the segment cutting, but it would be worth investigating the use of abrasive water jet to be able to perform the cut with an angle, making it easier to control the segment drop down the well. Getting the top part to fit into the lower section could be a potential showstopper, but two possible solutions could be to either make another axial cut on the top section and use a hydraulic tool to move it outwards to the casing, or use enough force to displace it.

Concept procedure:

1. Bisect the tubing section radially
2. Segment cut tubing part 1
3. Drop segments downwards the well
4. Perform axial cut on next section
5. Displace tubing part 2
6. Lower tubing part 2
7. Repeat until a large enough window is created
8. Log cement behind casing
9. If the cement is good, set secondary plug

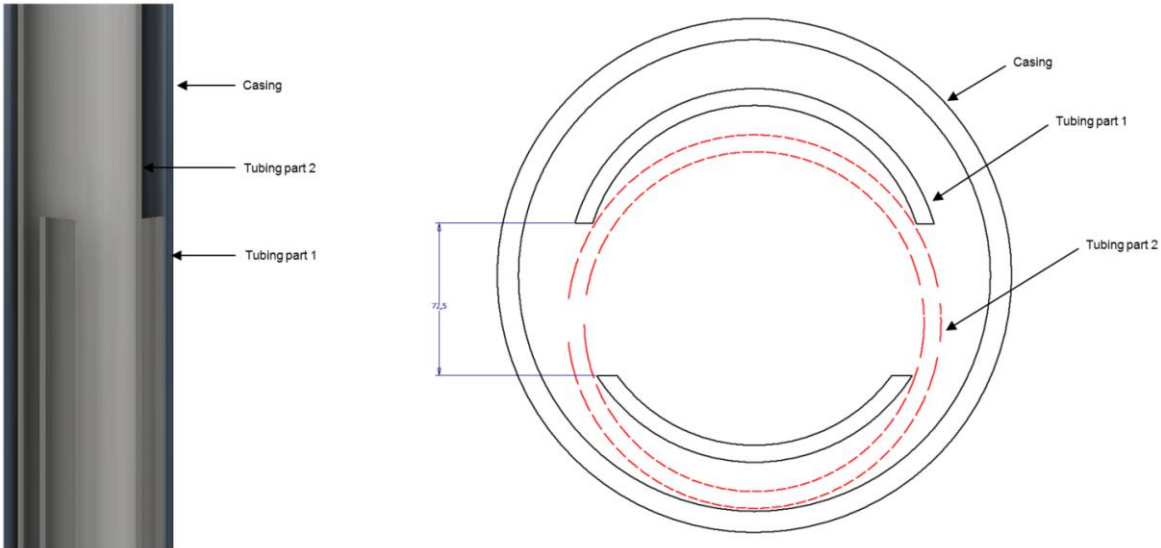

Figure 4-4: Segment cutting. Left: cross-section front view. Right: Top view.

4.5 Tubing Expansion with Axial Cuts

The tubing is made up by many 12 m tubular sections connected together by threaded connectors. An alternative approach could be to bisect the tubular sections between the connectors, cut one of the bisected tubular parts axially, expand that section and pull the bisected sections together, illustrated on Figure 4-5. If 5-6 m of the expanded tubing part could fit within the other one, a gap would be created downhole. By repeating the operation a couple of times, it would be possible to achieve a 30 m window. Challenges related to amount of axial cuts and how the tubing expansion can be performed would have to be addressed.

Concept procedure:

1. Bisect the tubular section by a radial cut
2. Cut axially one part of the tubular section
3. Expand the tubular part that has axial cut(s)
4. Pull the bisected tubular parts together
5. Repeat until a large enough window is created
6. Log the cement behind casing
7. If the cement is good, set secondary plug

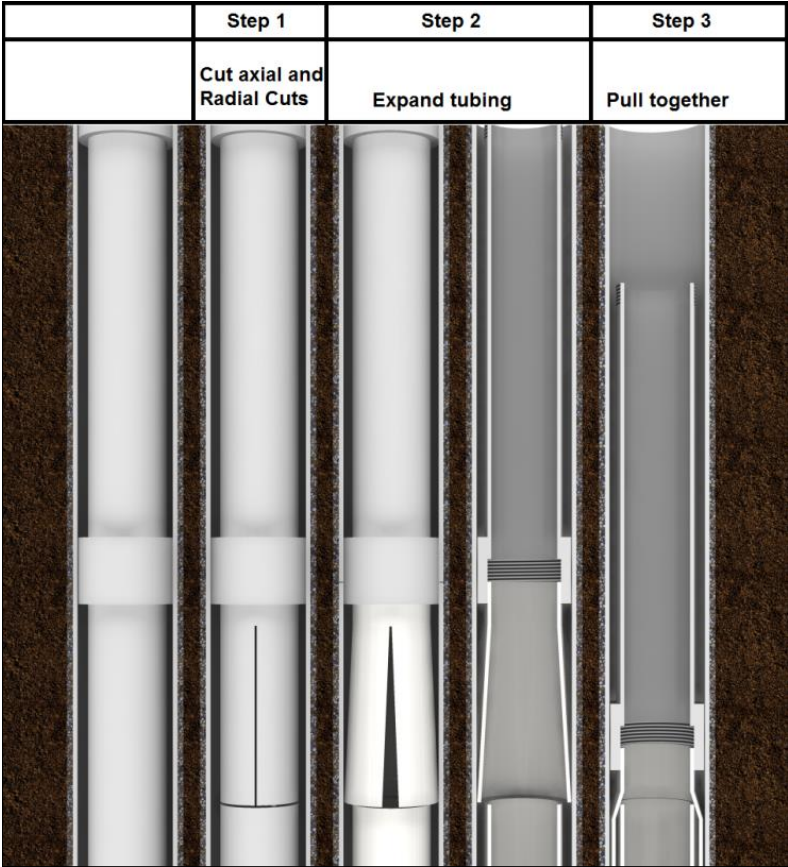

Figure 4-5: the basic steps for the tubing expansion with axial cuts method.

4.6 Tubing Expansion by Explosives

The approach is to expand the tubing above the plug setting area by the use of explosives. The approach is called *Earthmover – Explosive P&A system* [16] and would be executed by first cutting the tubing radially at the bottom of the plug setting area and expand the tubing above

the plug setting area by using explosives, illustrated on Figure 4-6. The technology to perform the PP&A operations by this method exist and by designing a suitable tool it could be possible to set the secondary plug quickly. However, the complexity might be too high. It would require many explosive charges to create the needed window, since it would be limited how much gap it is possible to create per explosive charge. It may also be challenging to prevent the tubing to fracture when the weight of the tubing below the area deformed by explosives increases.

Concept procedure:

- 1. Cut tubing axially at the bottom of the plug setting area
- 2. Run tool with enough charges to create the required envelope
- 3. Log cement behind casing
- 4. If cement behind casing is good, set secondary plug

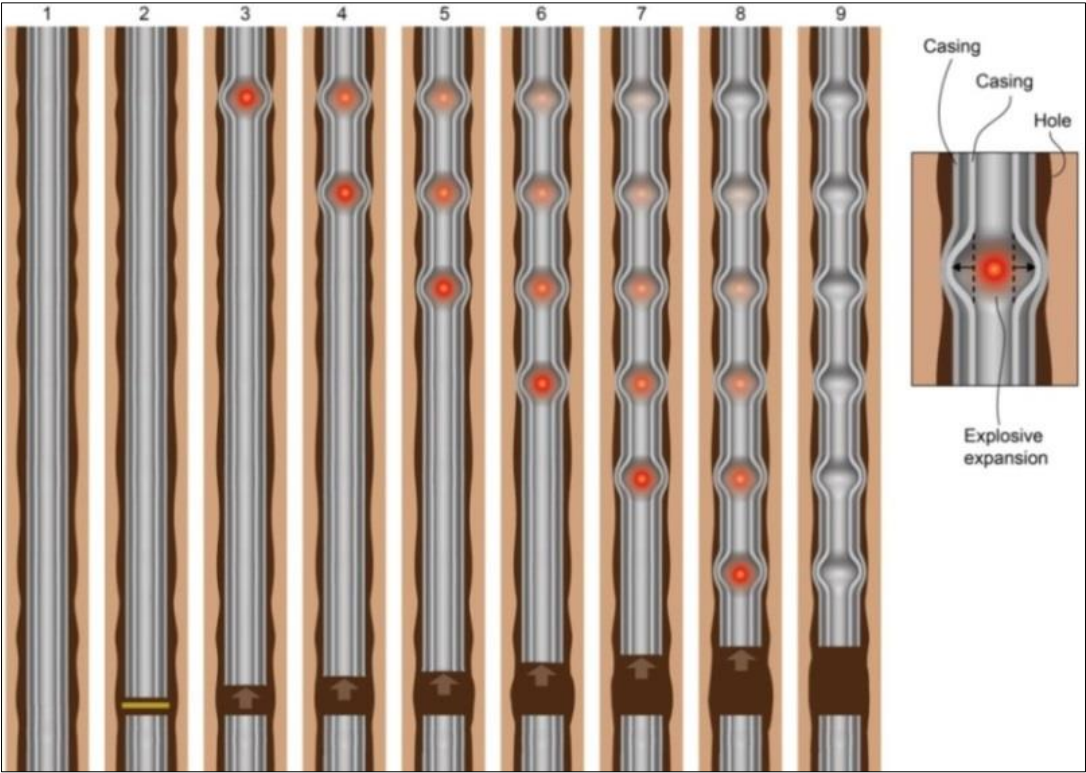

Figure 4-6: Tubing expansion by using explosives [16].

4.7 Discussion of Alternative Methods for Tubing Removal

The established approach to remove the tubing is to today to pull it. To meet the technical and safety requirements for a plug and abandonment operation means pulling is performed by a drilling rig. Drilling rigs are on the Norwegian continental shelf limited and using them for plug and abandonment work means less new wells can be drilled per year. They are also costly and new methods that can avoid the use of them are desired by the industry. The technology is available to do it from a LWIV [31], but environmental and HSE challenges may be an issue. If the tubing can be left in the well, it can be an important basis for safe and cost-effective P&A operations.

The alternative methods presented above all have the potential to be part of a larger rigless P&A operation, but some may be more suitable than others. To evaluate which of the proposed alternative methods is the most suitable, it is necessary to compare them by different categories. An evaluation based on five different categories has been performed. To set a premise for the evaluation, pull tubing has been included with a value of two in all categories. Each alternative has been given a number between one and three in each category, where one symbolizes worse than pull tubing, while three symbolizes better. The different categories are the following:

1. Equipment simplicity
2. Environmentally friendly
3. HSE
4. Operational speed
5. Operational simplicity

With *equipment simplicity* it is meant to what extend existing technology can be used and how complex the equipment / tool have to be to perform the operation. The category has been given a weighting of two.

Environmentally friendly is meant to what extend the alternative impacts the environment. A good ranking has been given to alternatives where the tubing can be left in the well.

HSE is meant to what extend the personnel is exposed to hazards. Pulling completions with low-radioactive deposits may occur which may be a handling and exposure issue.

Transporting, storing and handling of acids and explosives may also be potential issues. Methods involving handling acid or explosives have been given a low ranking, while methods not involving pulling tubing or hazardous equipment have been given a good ranking.

Operational speed implies the potential speed the alternative method has given it has the equipment required to perform it. Alternative methods that are believed to be faster than pulling the tubing have been given a high ranking while methods believed to be slower are given a low ranking. The category has been given a weighting of three.

With *operational simplicity*, it is meant to what extend the operation can be performed in a simple way. The use of advanced equipment to perform the alternative has been given a low ranking. The category has been given a weighting of two.

Based on the evaluation performed in Table 4-1, the methods with a total sum above two is worth investigating further and the most promising alternative being the tubing expansion with axial cuts that will be investigated further in the next chapter.

Table 4-1: Evaluation of alternative methods.

Alternative Methods \ Category	Category Weight	Pull tubing	Accelerated corrosion	Crushing the tubing downwards	Pull tubing 30 m	Section cutting	Tubing expansion with axial cuts	Tubing expansion by explosives
Equipment simplicity	2	2	1	1	1	1	2	1
Environmentally friendly	1	2	3	3	2	3	3	2
HSE	1	2	1	3	2	3	3	1
Operational speed	3	2	1	2	3	3	3	2
Operation simplicity	2	2	2	1	2	2	2	1
Evaluation sum		2	1,4	1,8	2,1	2,3	2,6	1,4

5 Tubing expansion with Axial Cuts

The most obvious way to do a tubular expansion would be through stress-controlled expansion with the use of internal pressure. Once the internal pressure exceeds the yield pressure, the tubing will expand. The expansion of the tubing could be looked upon as similar to burst test stopped at a pressure between yield pressure and burst pressure. The material hardening index, n , which corresponds to the logarithmic uniform strain, is a suitable measure for the formability of metals and used as a measure for achievable tubular expansion ratios. The max achievable expansion ratio, δ_{\max} at burst rupture pressure can be found from the formula [32]:

$$\delta_{\max} = \frac{\Delta d}{d} = \left(e^{\frac{n}{2}} - 1 \right) \cdot 100[\text{pct}] \quad (5.1)$$

For the most common API steel grades, the material hardening index, n can be found in Table 5-1 [33]. By applying equation 5.1, the max achievable expansion ratio with the material-hardening index, n on the most commonly used tubulars presented in API Bulletin 5C2 it can be found that it is only theoretically possible to do the necessary expansion on some of the tubulars. In Appendix A, it can be seen that the tubing sizes possible to apply enough stress to perform the necessary expansion on without rupturing the tubular are for 5 in. tubular steel grade H-40, J-55 and K-55 and for the 7 in. tubulars only the version with smallest wall thickness of steel grade H-40. The weakest steel grades are not commonly used on the N.C.S. The tubing is also a set of tubulars connected by threaded connectors, which may mean it is not possible to achieve wanted expansion over the thread region. That means any possible expansion would have to be applied in localized zones between the threads. Achieving a pressure above yield pressure in a localized zone downhole may not be possible with the current sealing technology. Imposing stress to achieve the expansion process may also cause failure due to localization at flaws in regions of pronounced geometric imperfections [32].

Table 5-1: Material Hardening Index

<u>API Steel grade</u>	<u>n</u>
H-40	0.14
J-55	0.12
K-55	0.12
L-80	0.10
N-80	0.10
C-90	0.10
C-95	0.09
P-110	0.08

An option that would be able to give higher expansion ratios for the same tubular with identical mechanical properties compared to internal pressure loading is to propel a mandrel through the tubing. The technology is currently used for expandable wellbore tubulars and the mandrels are designed in such a way that the expanded tubular has a final inner diameter that is larger than the maximum outer diameter of the mandrel. The area behind the mandrel is pressurized forcing the mandrel to move upwards and thus deforming the tubular in a controlled way. The mandrel is normally made in ceramics to prevent galling and to minimize friction and wear in the contact zone between the expanding tubular and the mandrel [32]. To use the technology to expand existing tubulars the mandrel would need to be no larger than the ID of the tubular and then be able to expand downhole. Expanding the mandrel in a way that would allow for tubing expansion may not be possible. It may also be challenging to propel the mandrel by backpressure since the operation would require the tubing to be radial cut for the mandrel to fit. This may require some extra sealing to reduce the required area that would be pressurized making it not a viable option to expand the tubing downhole either.

By axial cutting the tubing before expanding it, the tubing is no longer a multiple-connected body and thus the pressure required to plastically deform the tubing is reduced. Since the goal is to plug and abandon the well, there are no requirements of maintaining the tubular material strength since the cement plug is the barrier and thus plastically deforming the tubing is not a problem as long as it does not affect other parts of the plug and abandonment operation.

The expansion of the tubing with symmetric axial cuts can be calculated in similar manner as deflection of a beam with cantilever support, with moment of inertia equal to a hollow

semicircle. In appendix B it can be seen that the force required to get contact between a tubing with two axial cuts and the casing when a force is applied over a 1 m section of the inner diameter of the tubing is 600 N. By applying the same force to a 1 m section on tubing without axial cuts, the change of diameter is by using thick walled cylinder theory (internal pressure only) 0.0163 μm , in other words negligible.

Ideally, the operation can be performed with one axial cut, but it may be a challenge to deform the tubing uniformly by one axial cut, due to dissimilarity in the pressure distribution on the tubing. Uneven pressure distribution may cause the tubing to move more in direction, which may make it harder to pull the separated tubing parts together. To expand the tubing in a more uniform way, it may be necessary to add more cuts, e.g. two or four cuts for the cost of longer operation time. The expansion process may also affect the threaded region and cause unwanted fracture if the axial cut length is too long.

To determine the feasibility of the tubing expansion with axial cuts method, a list of predefined issues, or area of concern, which may affect the feasibility of the method for use in PP&A was reviewed. The main topics considered, included:

- Number of axial cuts necessary to perform the expansion
- Operational aspects
- Cost and time estimation

To decide the number of axial cuts necessary to perform the expansion a finite element analysis (FEA) has been carried out. The operational aspect looks upon how to use the results from the FEA in terms of tool design and step-by-step procedure based on the tool design. Cost and time estimation, gives a rough estimates on time usage and compare operation time and cost with pulling the tubing from a semi-submersible drilling rig and pulling the tubing from a light intervention vessel (LWIV).

5.1 Finite Element Analysis

The finite element analysis is an analysis to predict the physical behavior of systems and structures. The basis of a finite element analysis (FEA) relies on the decomposition of the domain into a finite number subdomains (elements) for which a systematic approximate solution is constructed. FEA reduces the problem of having finite number of unknowns by dividing the domain into elements and by expressing the unknown field of variables (solid, liquid or gas) in terms of assumed interpolation functions within each element. At specific points, the interpolation functions are defined in terms of the value of the field variables and are referred to as nodes. The nodes are usually connected to the elements and are located along the element boundaries [34]. The ability to approximate a quantity of irregular domains with finite elements makes the method a valuable and practical analysis tool for boundary value problems, such as tubing expansion.

5.1.1 Scope of the Analysis

The scope of the FEA is to investigate the amount of axial cut is required to perform the expansion. On Figure 5-1 the premise of the analysis is illustrated, a 12.5 m long tubing with threaded connectors in each end. It will be assumed the ideal length on the expanded tubing part is 6 m and the length between the axial cut and the tubing connector to be 0.5 m, to prevent damage on the threads.

The FEA will be performed on the expanded tubing section with the casing as boundary condition for max expansion. The base model will be a 6.5 m long tubing with a diameter of 177.8mm (7 in.) and a wall thickness of 8.05 mm. It will be three models; one axial cut, two axial cuts and four axial cuts. Each axial cut will have a 5 mm kerf and be 6 m long. The casing will have a diameter of 244.5mm (9-3/8 in.) and wall thickness of 10.05 mm. Impacts expanding the tubing has on the casing will for the purpose of this analysis be neglected.

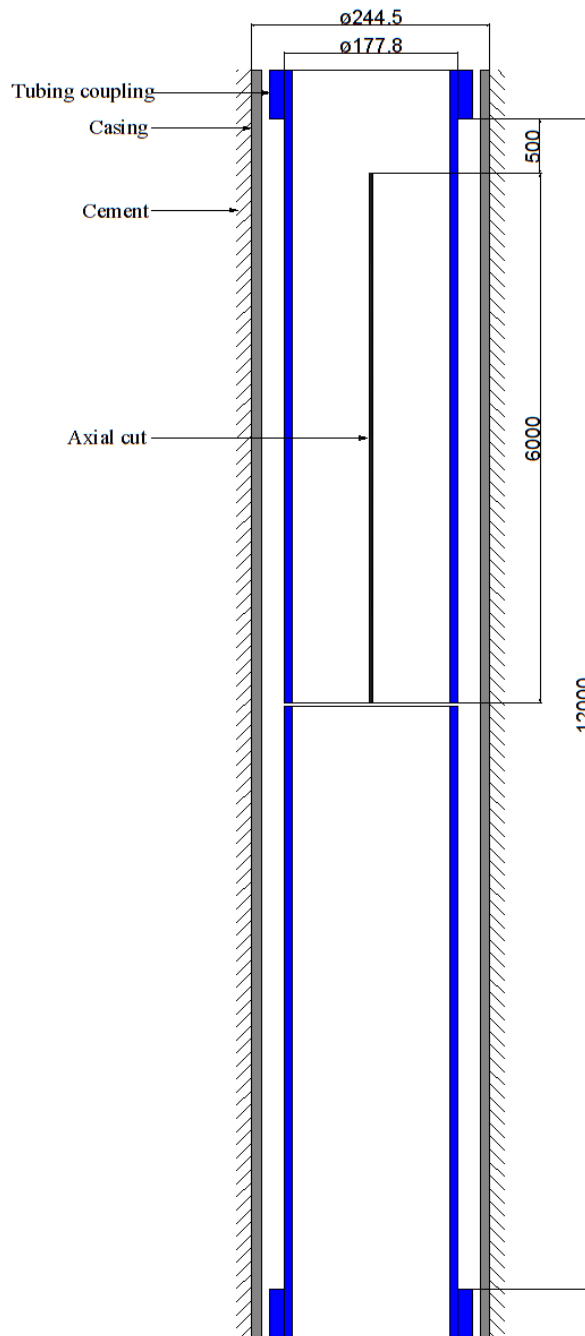

Figure 5-1: Illustration of scope of the analysis.

5.1.2 Model set up

The geometry of the models studied in this thesis is created in ANSYS DesignModeler 14.5 while the FEA are performed in ANSYS Mechanical 14.5. The different models are the following:

- Model 1: Tubing with one radial cut
- Model 2: Tubing with two radial cuts
- Model 3: Tubing with four radial cuts

5.1.2.1 Material Properties

The material properties used throughout the analysis are based on properties of Steel grade N-80 and can be found in Table 5-2.

Table 5-2: Material properties

Property	Value	Unit
Density	7850	kg/m ³
Young's Modulus	210	GPa
Poisson's Ratio	0.3	-
Bulk Modulus	175	GPa
Shear Modulus	80769	MPa
Yield Strength	551	MPa
Tangent Modulus	1450	MPa
Tensile Ultimate Strength	690	MPa

5.1.2.2 Geometry

The geometry of the three models mentioned initially, will be presented in this sub section. The stiffness behavior is set to flexible for all parts and the models are based on the dimensions listed in Table 5-3. The difference between the models is limited to the amount of axial cuts, as can be seen on Figure 5-2 - Figure 5-4. Model 2 is divided into three sub models, a, b and c representing differences in applied pressure distribution (illustrated in chapter 5.1.2.6)

Table 5-3: Model dimensions

Property	7 in. Tubing	9-5/8 in. Casing
OD [mm]	177.80	244.50
ID [mm]	161.70	224.40
Wall thickness [mm]	8.05	10.05
Length [mm]	6000	6000
Cut length [mm]	5500	-
Cut kerf [mm]	5.00	-

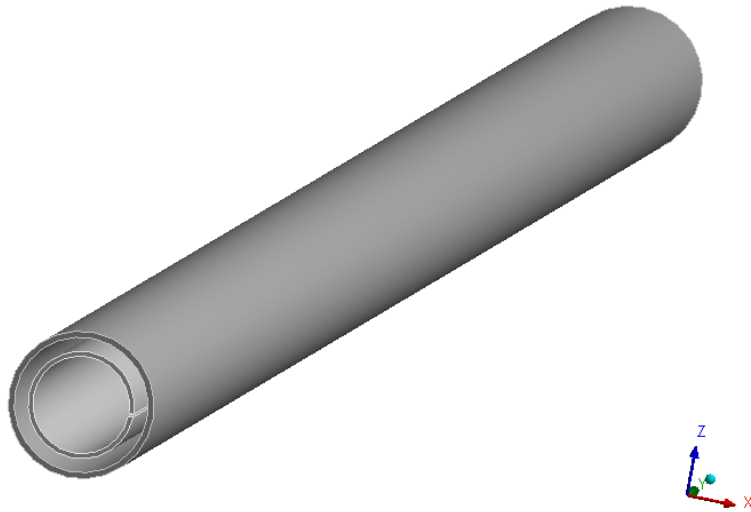

Figure 5-2: Model 1 – Tubing with one radial cut.

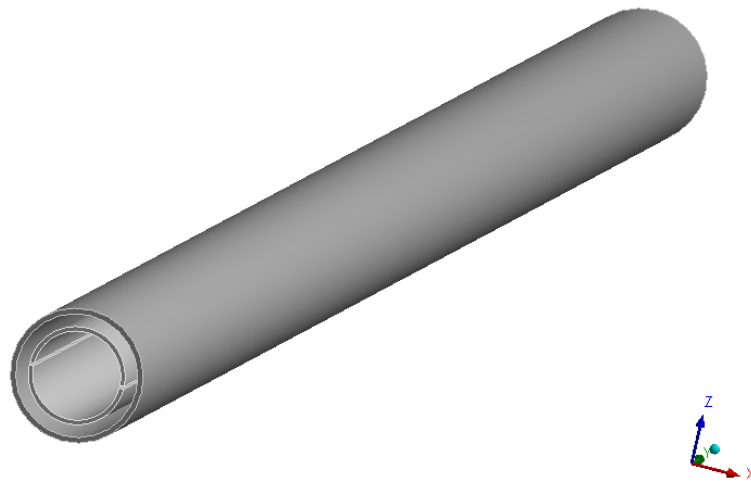

Figure 5-3: Model 2 – Tubing with two radial cuts.

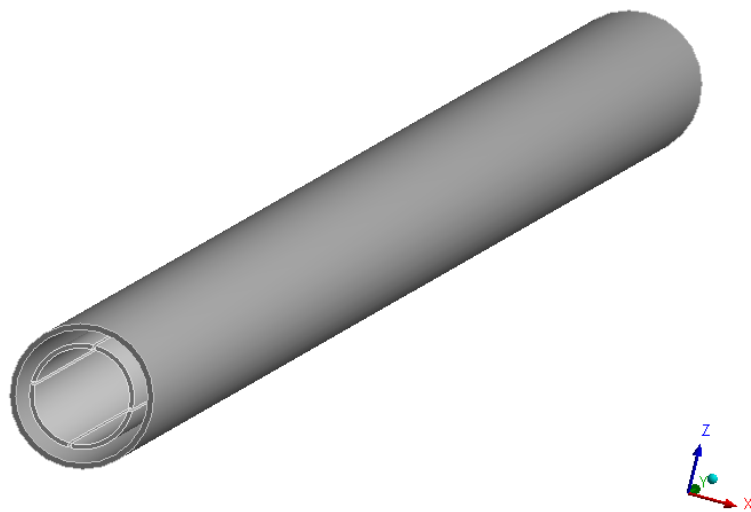

Figure 5-4: Model 3 – Tubing with four radial cuts.

5.1.2.3 Coordinate System

The global coordinate system illustrated on Figure 5-5 is representative for all models.

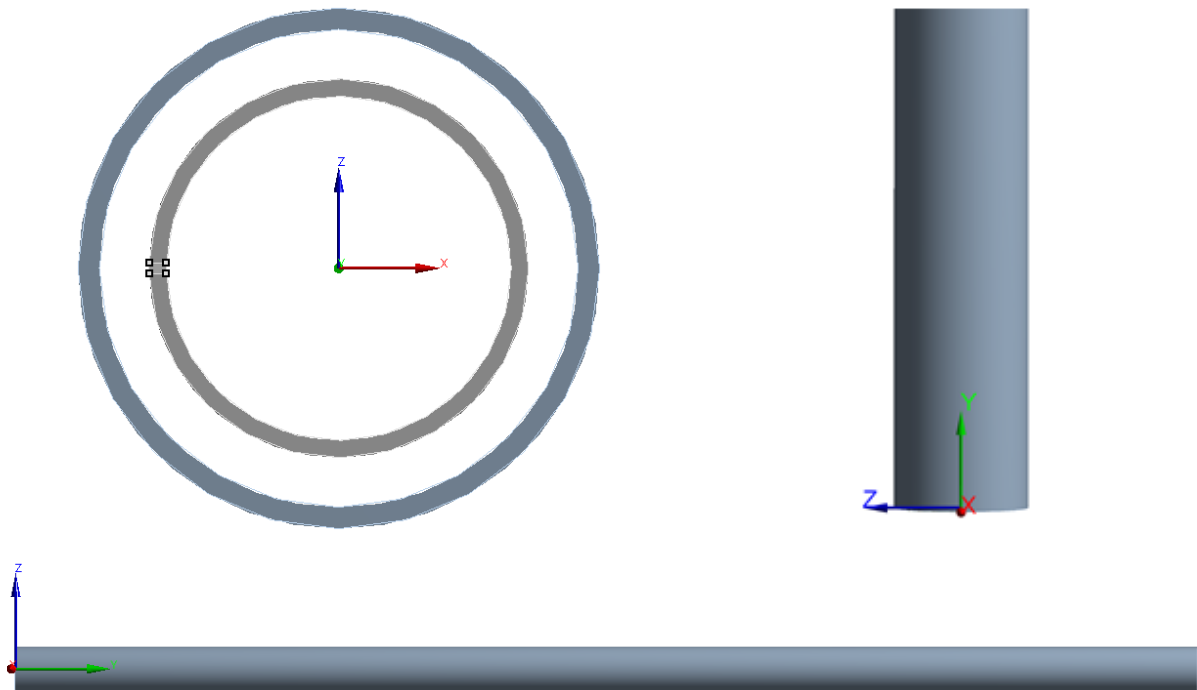

Figure 5-5: Global coordinate system.

5.1.2.4 Mesh

Meshing is the process of dividing the model into elements. Having a high mesh density increases the accuracy of the analysis, but also increases the computation time. Consideration should therefore be given to the number of elements in the model and the quality of the mesh [35]. On complex models, it may be wise to have a high mesh density on critical points and a less dense on uniform areas. This may reduce computation time without significant loss of accuracy.

In ANSYS, it is possible to review statistics on the mesh that has been created. The amount of elements and nodes are presented, and a series of different values for determining quality of the mesh are generated. The element quality provides a composite quality metric that ranges between zero and one. A value of one indicates a perfect cube or square while a value of zero indicates that the element has a zero or negative volume [35].

To keep the models as similar as possible, it has been used the same mesh settings on all the models. To save computation time the element size is smaller on critical areas such as the contact region and the cut end region compared to areas of less critical importance. The element sizes used can be found in Table 5-4 and Figure 5-6 to Figure 5-8 illustrates the mesh on Model 1.

Table 5-4: Element sizes used.

Section	Element size
Contact	30 mm
Tubing – Cut region not in contact	90 mm
Tubing - End of cut region	30 mm
Tubing – uncut region	90 mm
Casing	150 mm

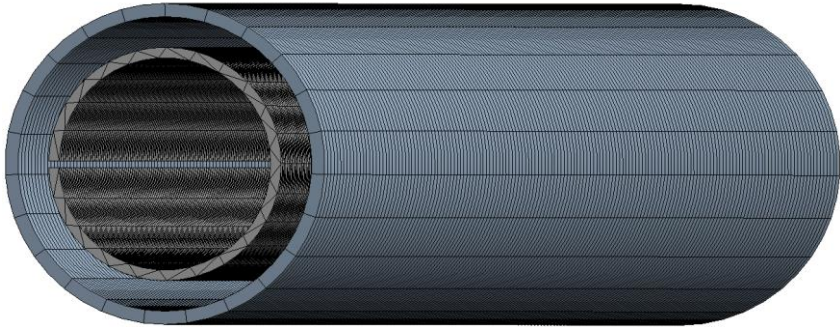

Figure 5-6: Mesh casing and tubing.

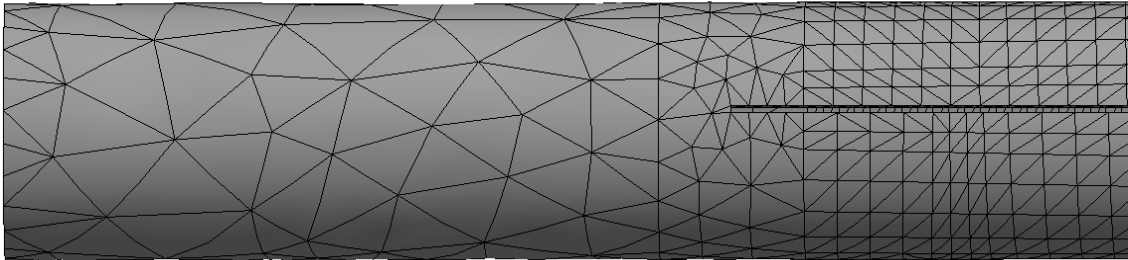

Figure 5-7: Mesh at cut end region.

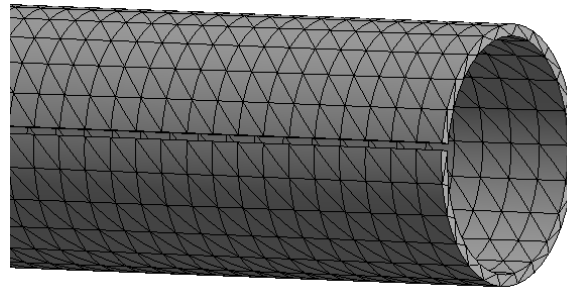

Figure 5-8: Mesh tubing start of cut.

5.1.2.5 Contact

When two separated surfaces touch each other such that they become mutually tangent, they are said to be contact. In ANSYS mechanical, physical contacting bodies do not interpenetrate and a relationship between the surfaces must therefore be established to prevent them from passing through each other in the analysis. In ANSYS Mechanical the following types of contact is available:

1. Bonded
2. No separation
3. Rough
4. Frictionless
5. Frictional

With *bonded* contact, the surfaces are not allowed to separate regardless of gap, penetration, loading and behavior of other parts/contact. *No separation* is similar to bonded except relative motion between the surfaces allowed. *Rough* contact allows the surfaces to separate depending on load, but not slide ($f=\infty$). *Frictionless* contact the surfaces can slide freely ($f=0$) and contact can open and close depending on the load. *Frictional* contact the surfaces are allowed to slide by a defined coefficient of friction (f = user defined) and can open close.

For nonlinear solid body contact of faces, two main formulations are used, pure penalty (equation 5.1) or augmented Lagrange (equation 5.3) formulation. The main difference between them is that the latter augments the contact force by including an extra term, λ and is therefore less sensitive to the magnitude of the contact stiffness. Generally the augmented Lagrange formulation provides a higher accuracy compared to the pure penalty formulation,

but it may require additional equilibrium iterations if penetration is too large [36]. For large-deformation, problems augmented Lagrange formulation is recommended since it adds additional controls to automatically reduce penetration [36].

$$F_{\text{normal}} = k_{\text{normal}}x_{\text{penetration}} \tag{5.2}$$

$$F_{\text{normal}} = k_{\text{normal}}x_{\text{penetration}} + \lambda \tag{5.3}$$

For the models, a frictionless contact between the tubing and the casing was chosen due to reducing issues related to convergence. Figure 5-9 illustrates the contacting surfaces where the tubing (red) is defined as the contact body while the casing (blue) is defined as the target body.

The formulation used was augmented Lagrange due to large-deformation was expected. The initial gap between the tubing and the casing is large and to enhance convergence, time step control was added. The time step control chosen was “predict for impact”. “Predict for impact” reviews the contact behavior at the end of each substep to determine whether excessive penetration or drastic changes in contact status has occurred and predict the minimal time increment needed to detect future changes in contact status [36].



Figure 5-9: Contact setup between the tubing and casing.

5.1.2.6 Loading and Boundary Conditions

For structural mechanical analysis in ANSYS the loads, including boundary conditions and externally or internally applied force functions can be divided into six categories: DOF (degree of freedom) constraints, forces, surface loads, body loads, and inertia loads [37].

- DOF constraint fixes a degree of freedom to a known value and is specified by adding displacements and symmetry boundary conditions.
- Force is a concentrated load applied at a node in the model and is specified by adding forces and moments.
- Surface load is distributed load applied over a surface and is specified by adding pressure.
- Body load is volumetric or field load and is specified by adding temperatures and fluencies.
- Inertia loads are attributable to the inertia of a body and is specified by adding gravitational acceleration, angular velocity, and angular acceleration.

The loads applied to the models were; fixed support, displacement and pressure.

- Fixed support was added on the end of the tubing on opposite side of the axial cut and on the inside of the casing, to reduce computation time.
- Displacement with X and Z component free and Y component 0, was added to the outside of the tubing to enhance convergence.
- Pressure applied in two load steps on model 1, model 2a, model 2b, and model 3, illustrated on Figure 5-10.
- Pressure applied in one load step on Model 2c.
- Pressure applied to the inside of the tubing around the circumference on model 1, model 2a and model 3.
- On model 2b, pressure was applied to a smaller fraction of the tubing circumference. The area extends from the start of the cut to 50° outwards from the center.
- The models illustrated on Figure 5-11 were pressurized with various pressures and with different surface areas, where the face length was the variable.
- Pressure applied to a same fraction of the tubing as model 2b on model 2c, but with a various fixed distance between the cut starting point to the pressurized area, illustrated on Figure 5-12.

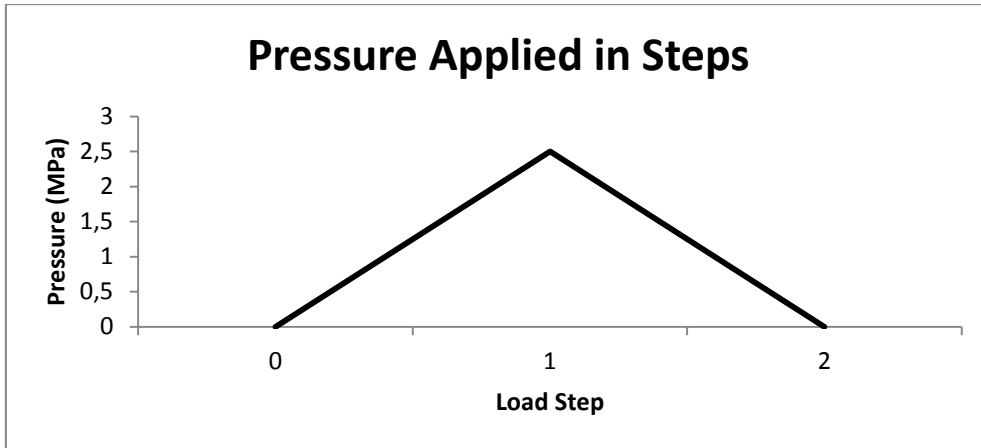

Figure 5-10: Pressure applied in steps.

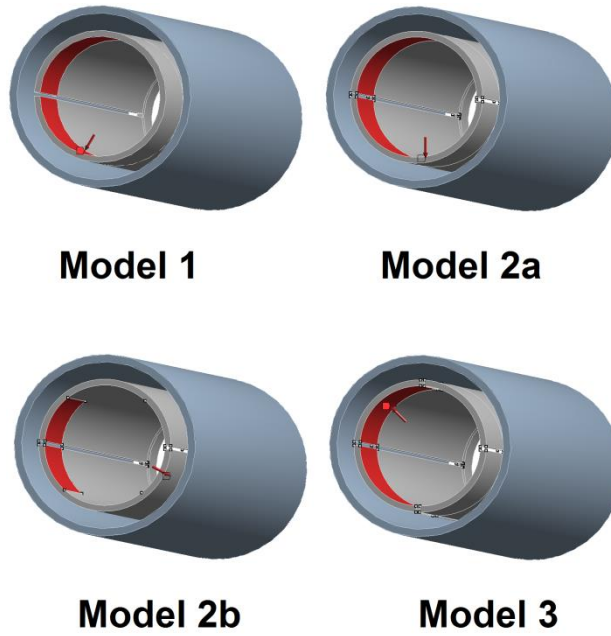

Figure 5-11: Pressure distribution.

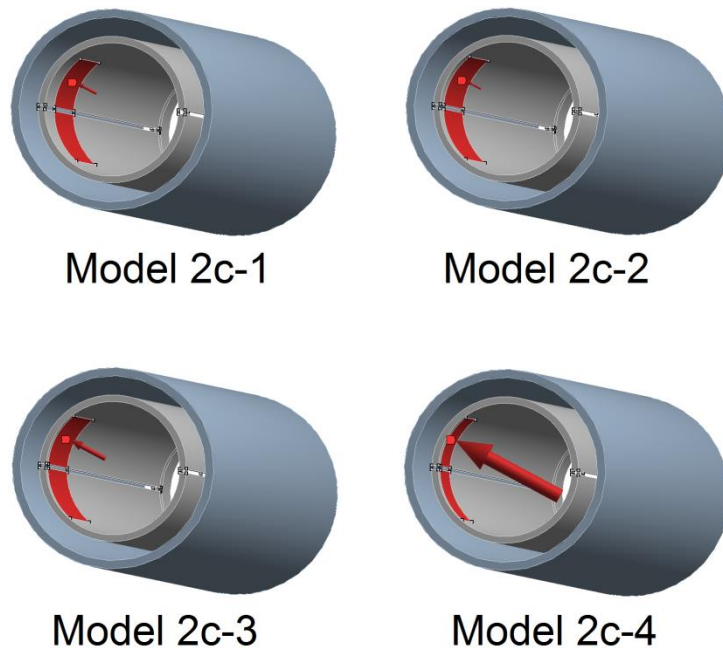

Figure 5-12: Pressure distribution on Model 2c.

5.1.3 Results

The results section is divided into two parts. The first part, plastic deformation approach looks upon the force required to plastically deform the tubing to fit around the unaltered tubing part. The second part, pressure-fitting approach looks upon the minimum force required to expand the tubing to fit around the unaltered part with pressure applied to the expanded tubing part.

5.1.3.1 Plastic Deformation Approach

To measure deformation, probes located on the inner diameter of tubing have been placed. Figure 5-13 illustrates the probe placement on the different models. Figure 5-14 illustrates the probes distance to center of the tubing in load step two (pressure = 0) for various pressure scenarios on model 1, model 2a, model 2b and model 3. The different points pressure face length, pressure, max stress and probe deformation can be found in appendix C. On Model 1 probe 2 is equal to the sum of probe 2 and 3 and the black line represents the tubing outer radius.

The simulation points with high enough plastic deformation for the expanded tubing part to fit around the unaltered tubing part in load step two is listed in Table 5-5. Figures representing deformation in load step 2 and stress distribution for the simulation point with highest applied force to can be seen in Appendix C.

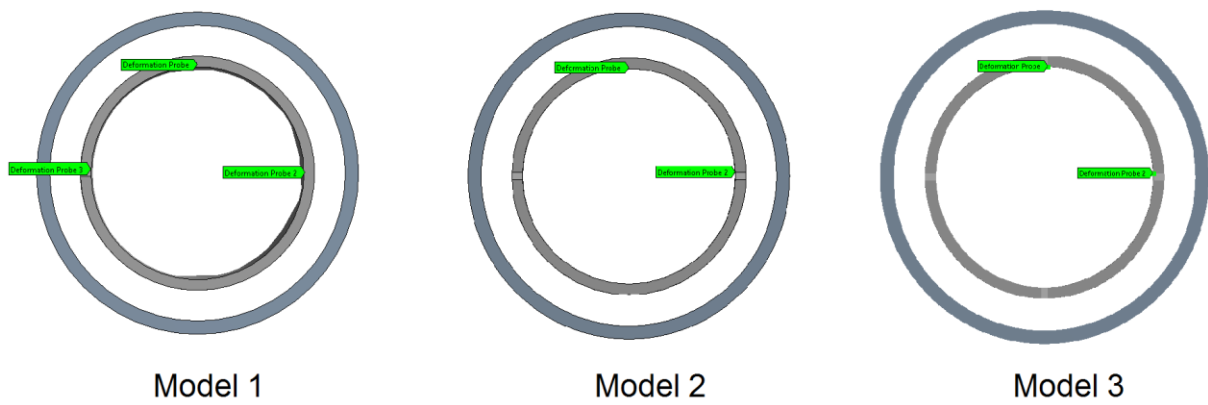

Figure 5-13: Probe placement.

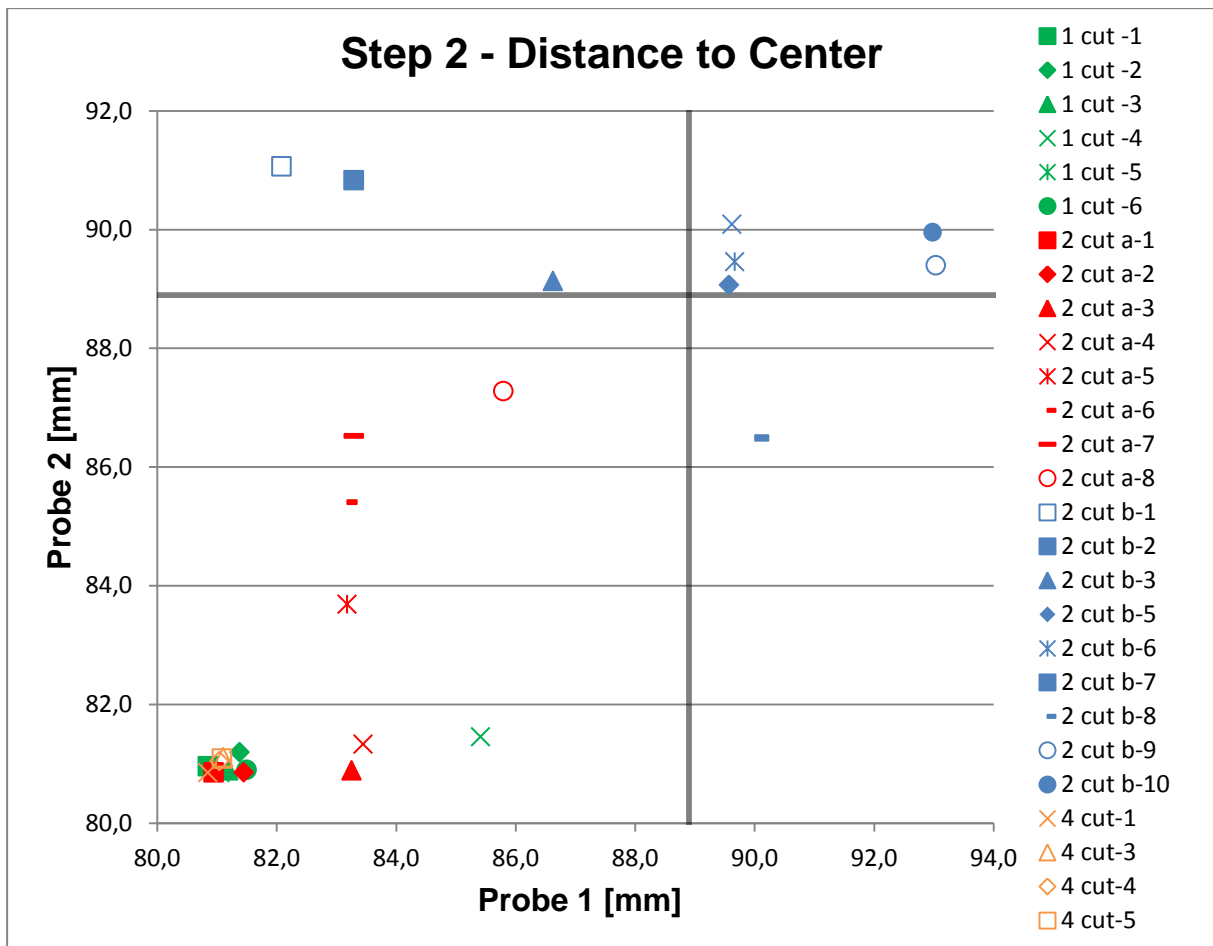

Figure 5-14: Plastic deformation on the tubing.

Table 5-5: Points with high plastic deformation.

Point reference name	Face length mm	Pressure MPa	Total force MN	Probe 1 Step 1 mm	Probe 1 Step 2 mm	Probe 2 Step 1 mm	Probe 2 Step 2 mm
2 cut b-5	3000	4.0	3.3	104.1	89.6	98.0	89.1
2 cut b-6	3000	5.0	4.1	104.1	89.7	98.9	89.5
2 cut b-7	3000	6.0	4.9	104.1	89.6	100.0	90.1
2 cut b-9	4000	4.0	4.4	104.1	93.0	98.0	89.4
2 cut b-10	4000	5.0	5.4	104.1	93.0	98.9	90.0

5.1.3.2 Pressure Fitting Approach

Three variations of distance between the tubing end and the start of the pressurized area was simulated. The distances were 500 mm (reference point 2c-1), 200 mm (reference point 2c-2) and 100 mm (reference point 2c-3). The face length for each of them are 1000 mm. The 100 mm fixed distance were also were simulated with a 500 mm face length (c2-4). Each point were simulated with different pressure which can be found in appendix D. Figure 5-15 represents the deformation for each simulation point and Figure 5-16 represents the total force applied vs deformation on probe 2.

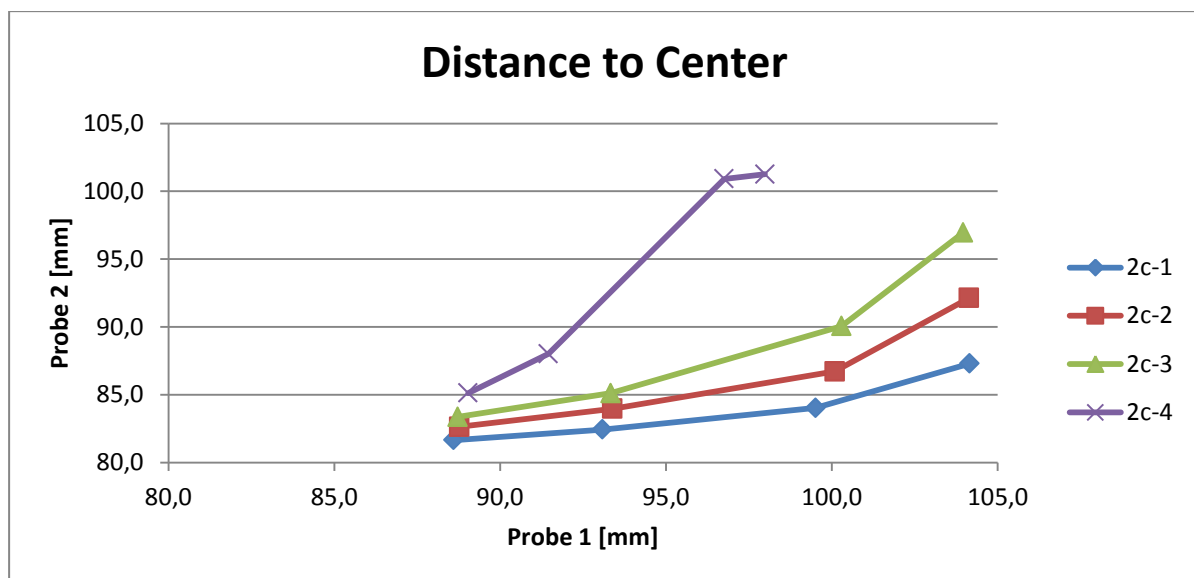

Figure 5-15: Deformation on the tubing.

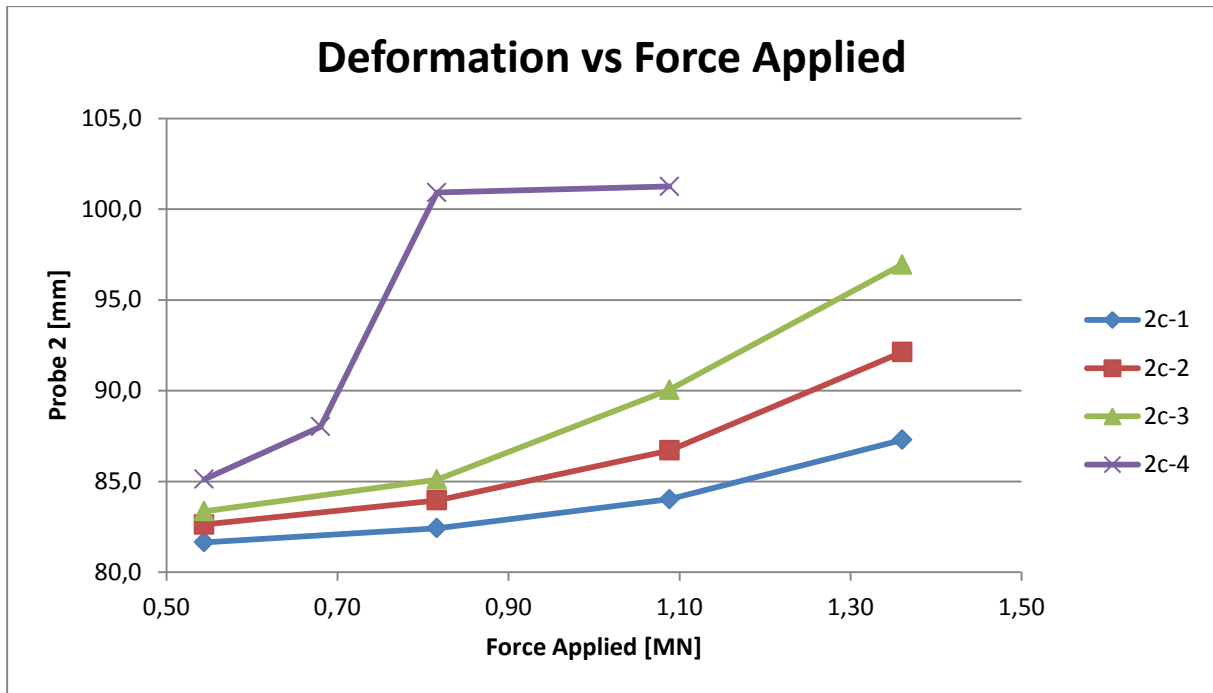

Figure 5-16: Total applied force vs deformation output.

5.1.4 Intermediate FEA Discussion

The results shows that it may not be possible to plastically reduce the tubing by just one axial cut. Pressurizing the whole circumference of the tubing with two axial cuts created problems due limited expansion in X-direction and thus the requirement of minimum having the deformation probes outside of the original outer diameter was not met.

By pressurizing a smaller area only around the cut area, the simulation revealed that the expanded tubing part might have a form that enables it to fit around the unaltered tubing part. However, a large amount of force is required to deform the tubing, which may be above what is practically possible to achieve. The output in terms of distance between the deformed tubing part and unaltered tubing part would also be minimal, meaning it may be challenging to fit the parts together.

With four axial cuts, getting contact between the tubing and the casing required a low amount of force. However, high stress around the end of the cut limited the amount of force possible to apply before it became an unconvergent solution. It is to believe that adding more simulations point with pressure applied over a larger area would give high enough plastic deformation for the expanded tubing to fit around the unaltered tubing part. It was however

not performed due to a rather long computation time per simulation and it may be favorable to fit the tubing parts together without plastically reduce the expanded part compared to adding more axial cuts.

An alternative to deform the tubing plastically was also simulated. By fitting the tubing parts together while the expanded tubing part is pressurized would lower the force required to perform the operation. The pressurized zone can therefore not start on the outer ends of the tubing (where the pressurized area starts for the plastic deformation approach). It is believed that the further inwards the expansion process is performed the easier it may be to fit the tubing parts together, but at the cost of higher pressure required to perform the expansion process. For that reason it was simulated the expansion with fixed distances between the tubing end and the start of the pressurized area between 100 and 500 mm. The simulation showed that is favorable to pressurize a smaller area compared to a larger area with same amount of force applied. The simulations show applying a 6 MPa pressure to a small area around the cuts that stretches 500 mm inwards and starting 100 mm from the tubing end is the favorable way to perform the expansion. The simulations also suggest applying a higher pressure than 6 MPa gives limited additional deformation. Reducing the pressurized area below 500 mm may be favorable in terms of reducing the required force to perform the expansion, but it may also limit the tooling choices.

The area that was pressurized around the cut was not optimized and it may therefore be a potential to increase the deformation with the same amount force applied.

The mesh settings used may have influenced the FEA and reduced the accuracy. However, results in early stages of creating the models with higher mesh density gave similar results as the current mesh density used. Because of the minimal impact lowering the element sizes had, combined with the method being explored on a concept stage, it was decided to focus on lowering the mesh density to increase the amount of simulations possible to perform per day.

5.2 Operational Aspects

To perform the operation in a safe and efficient way, it may be necessary for the operation to use a single-trip tool that is able to cut, expand and pull in one trip. It may not be economically viable without a single-trip tool due large amount sub-steps that has to be performed. The focus on the operational aspect will therefore be to look upon ways to perform the three sub-steps cut, expand and pull and how the overlaying design has to be to integrate them into one tool.

5.2.1 Methods for Cutting Tubing

Cutting the tubing cuts can be divided into radial and axial cuts. The cutting method must therefore be able to perform both of these, and preferable be able to be integrated in a one-trip tool system where the use of a rig is not required. It may therefore be able to be deployed by either coiled tubing or wireline. Several cutting methods may be suitable for cutting the tubing. These are, but not limited to abrasive water jetting, chemical cutting, explosive cutting, mechanical cutting and thermal cutting.

5.2.1.1 Abrasive Water Jetting

Abrasive water jetting uses a mixture of water and abrasive to cut through materials. The cutting is done with water pressurized up to 3500 bar with an abrasive such as garnet added into the flow. In the cutting head, the pressurized flow is forced through a small diameter orifice. By doing this the pressurized water accelerate and exit the cutting head at very high speeds, making it possible to cut through any material [38]. The most suitable method for cutting tubulars is, Abrasive Water Suspension Jet (AWSJ) which works by pumping a premixed suspension directly through the nozzle, removing the need for mixing. Tests performed in hyperbaric chambers simulating water depth down to 6100 m has shown that AWSJ can be used for underwater applications [39].

Abrasive water jetting is currently being used for wellhead removal from LWIV [26], but has not been used for cutting tubulars further down the well and thus the parameters influencing the cutting method is of interests. The abrasive water jetting is a complex process since the mechanism of material removal depends on the level of various process parameters.

Feil! Fant ikke referansebildet. illustrates the various input parameters influencing the output parameters. The cutting performance is often evaluated in terms of depth of the cut, kerf structure, surface topography and material-removing rate [40]. The main parameter, cut depth, and how to achieve high traverse rate is of interest for cutting of well tubulars. Parameters influencing the cutting depth are explained further in appendix E.

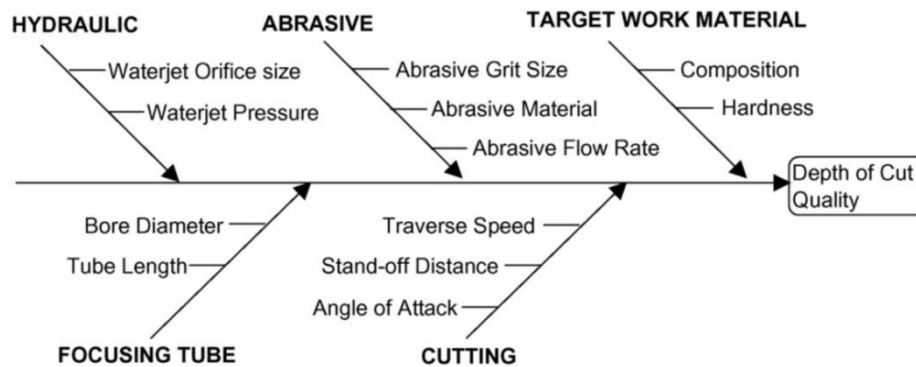

Figure 5-17: Process parameters influencing the abrasive water jetting process [40].

Additionally, for cutting well tubulars, factors such as pressure loss from the pump to the cutting head are of interest. For fluid flowing through a pipe, and especially on small diameter pipes the pressure loss due to friction may be substantial. AWSJ also cuts by accelerating solid particles where the aim of the flow is to carry those solid particles. The flow type is therefore by definition a slurry flow comprised by two different flow phases, the total mixture flow characterized by the pipe Reynolds number, Re and the relative flow between the solid particles and the carrier fluid characterized by the particle Reynolds number Re_s . The two phases influence each other and which may cause blockages [41].

By assuming the flow will act similar to a single-phase flow, the pressure loss due to friction can however be managed. By using more than one cutting head and a larger pipe to transport the fluid from the pump to a flow splitter, placed before the cutting heads, the pressure loss due to friction is decreased [28].

Figure 5-18 illustrates the pressure loss due to friction as a function of tubing diameter and is based on a 276 MPa nozzle pressure, $5.94 \times 10^{-5} \text{ m}^3/\text{s}$ water flow rate per nozzle and 3000 m cutting depth. It can be seen that increasing the pipe diameter used to transport the fluid

decreases the pressure loss due to friction and may enable the use of AWSJ for downhole cutting.

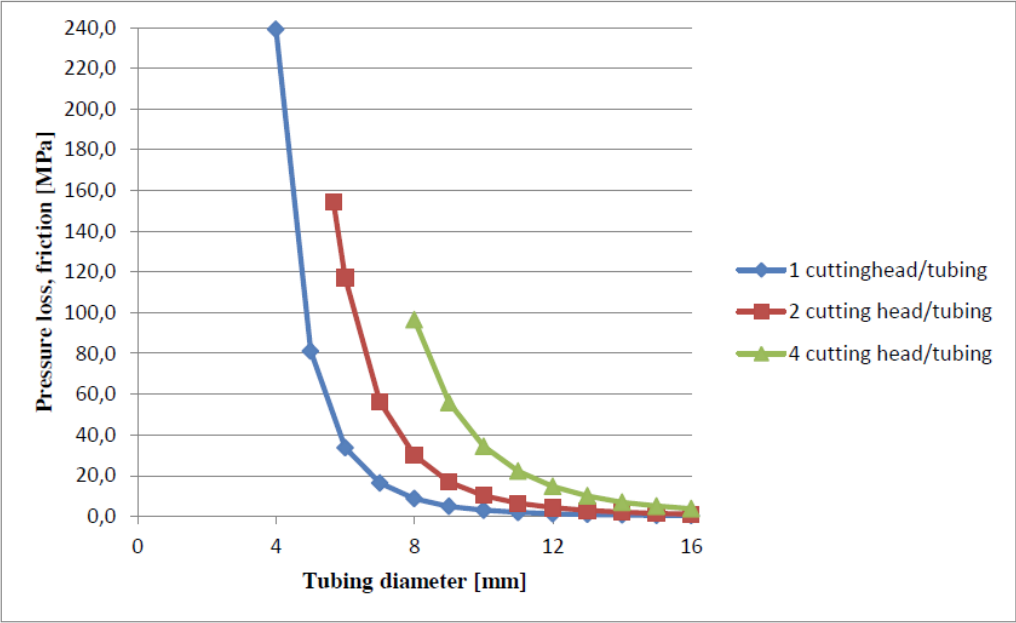

Figure 5-18: Pressure loss due to friction as a function of tubing diameter [28].

5.2.1.2 Chemical Cutters

Chemical Cutters function by directing high-pressure jet of highly corrosive material in a circumferential pattern against the tubular wall. The cuts performed by chemical cutters are usually not 100% as illustrated on Figure 5-19 and some degree of overpull is required. Since the method revolves around chemical reactions, it is very susceptible to the environment it cuts in. for example the chemical used, Bromide Trifluoride (BrF_3) has been recorded to be unstable in contact with bromide completion fluid [42].



Figure 5-19: Cut performed by a chemical cutter [43].

5.2.1.3 Explosive Cutters

Explosive cutting tools are based on similar principles as perforating with shaped charges with the main difference being it sends out a radial 360° explosive jet. Explosive cutters have the advantage of not having any movable parts and are able to cut through tubulars in all fluid environments [44]. The explosive cutters are when the correct size is selected, able to cut through the tubulars without damaging adjacent tubulars [45]. Some flaring after the cut is completed may be expected when using explosive cutters, illustrated on Figure 5-20.



Figure 5-20: Explosive Cutting tool and a pipe end after cutting with an explosive cutting tool [44].

5.2.1.4 Mechanical Cutters

Mechanical cutters work by removing thin slices of the tubular by mechanical means. The cutting is normally done by using cutting blades activated by either centrifugal- or hydraulic force while rotating, or alternatively by a blade rotating at high rpm, as illustrated on Figure 5-21. The newest type of mechanical cutting tools is electrical and can be deployed by either wireline or tractor. The electric-mechanical cutters offers the capabilities to perform many cuts at a single run and without the need to handle hazardous chemicals or explosives is required [46]. However, mechanical cutters are slow compared to explosive and chemical cutters and have the risk of being stuck when it cuts in compression.



Figure 5-21: Electric-Mechanical cutters. Left: Blade solution [47]. Right: knives solution [48].

5.2.1.5 Thermal Cutters

The type of thermal cutter that currently has been used downhole is plasma cutters (also known as Radial Cutting Torch). The cutter contains a heat-generating source of thermite material, which is a mixture of aluminum, iron oxide and fluorocarbon. An igniter initiates a deflagration reaction, between the aluminum and iron oxide. The increased temperature from the deflagration reaction causes the fluorocarbon to decompose. The resultant from the decomposition is a gaseous product that expands, forcing the molten metals through a nozzle. The molten metals then form a high velocity liquid jet, traveling in the order of 200-250 m/s. The impingement of the liquid jet erodes through the tubular wall. The tool has the advantage of being a fast non-explosive method without being affected by wellbore fluids or material composition. The radial cutting torch is however affected by hydrostatic pressure, and as the hydrostatic pressure increases, the liquid jet temperature and velocity decreases. For an effective cut the molten metals needs to reach a temperature between 2700°C and 3300 °C and a liquid jet velocity between 240 and 300 m/s [49].

Other thermal cutting methods such as laser cutters and oxy-fueled cutters are not suitable for downhole cutting operations without further technology advancement [28].

5.2.2 Intermediate Discussion

The industry has traditionally used explosives and chemical cutters for cutting operation downhole [50]. Recent developments have introduced cutting methods such as electric-mechanical cutters and abrasive water jetting. Even though they have a lower cutting speed than the traditional ones, they do not have the same issues related to reliability. The development related to downhole cutting operations has focused on freeing stuck tubulars or cutting tubulars to modify a production completion installation and less on axial cutting operations. This may suggest an omnidirectional cutting method such as AWSJ would be the preferred choice for this cutting operation. However, there are uncertainties related to downhole AWSJ cutting due to limited empirical data [28]. Tests performed in hyperbaric chambers suggest it is possible use AWSJ for deep water application as long as the nozzle pressure is high enough [39], but increasing the pressure creates additional problems related to transporting the flow from the pump and to the nozzle in terms of increased friction loss and demands related to the transport pipe. It could be solved by increasing the pipe

dimensions transporting the liquid mixture, but at the cost higher requirements to wall thickness [28].

Electric-mechanical cutters generate a lot of heat during the cutting operation, which in traditional mechanical industry is solved by adding coolant. In a well, the wellbore fluid may be good enough coolant for the cutting operation, which the design of the electric-mechanical tools would suggest. Because of how they are designed, they will naturally struggle with cutting operations required to be performed when the tubular is in compression. It would therefore be important to know whether the tubing is in a compression or tension state before starting the cutting operation. In cases where the tubing is in compression, it may be preferable to manipulate the tubing into a tension state. This can be done for example with the use of packers. Since the current electric-mechanical cutters are designed to radial cut the tubing, some modifications to existing solutions would be required to perform the axial cut. The axial cut may possess a challenge, but by using axial-to-radial gears, it will be assumed possible. Another benefit of electric-mechanical cutters is that it would be possible to deploy the tool by wireline instead of coiled tubing. Wireline operations are generally cheaper and quicker than coiled tubing, making electric-mechanical cutters a better solution than AWSJ.

5.2.3 Expansion Tool

The simulation illustrated that the required force to expand the tubing after it has been axial cut is low. Tools used for expandable tubular is as stated earlier not possible to use since the mandrel being used is not expandable in itself. Since the pressure needed to expand is low, it is possible to use alternative solutions such as inflatable packers. Inflatable packers are normally used for zonal isolation illustrated on Figure 5-22 and works by pumping fluids into an inflatable element. The inflatable packers have a high inflation ratio and are normally expanded with coiled tubing [51]. It may however be a problem by using inflatable packers because it is questionable if they are able to be re-used as much as the tubing expansion method would require and if sharp edges from the cutting operation could punch holes in the packer.



Figure 5-22: Inflatable packer used for zonal isolation [52].

A more suitable way to expand the tubing may be by using hydraulic force. By having a tool based on similar principles as a typical exhaust pipe expansion tool, illustrated on Figure 5-23, using hydraulic force instead of force generated from a wrench the expansion it may be possible to have simple tool able to carry out the operation. The tool with expandable walls connected to a cylinder by a rod, would force the tubing to expand when the cylinder is pressurized. Figure 5-24 and Figure 5-25 illustrates the tool concept. Based on the calculations presented in appendix F and the suggested expansion pressure in the FEA, the piston cylinder would require a 63MPa inlet pressure to expand the tubing.



Figure 5-23: Typical pipe expander tool [53].

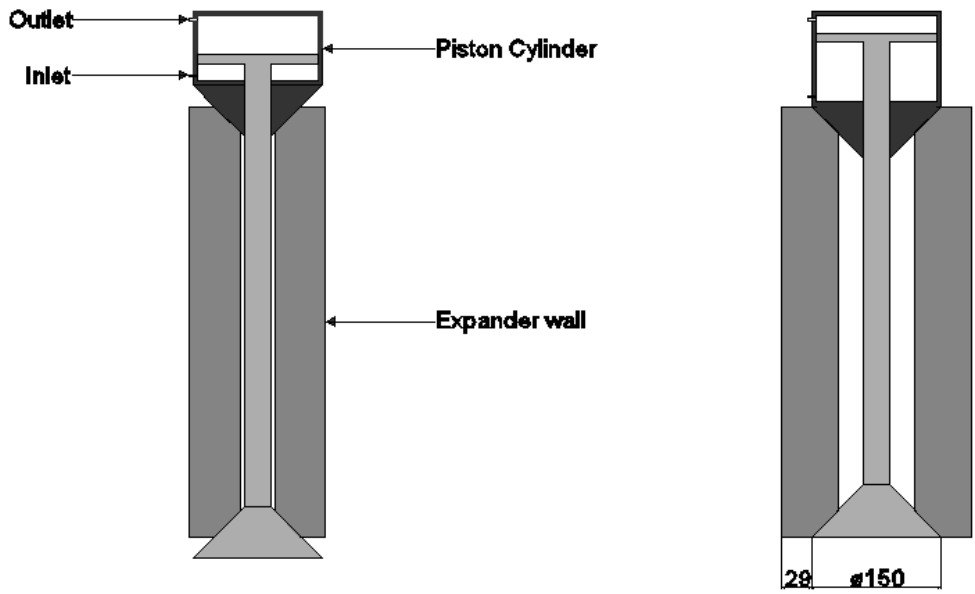

Figure 5-24: Side view - Tubing expansion tool. Left: before expansion. Right: max displacement

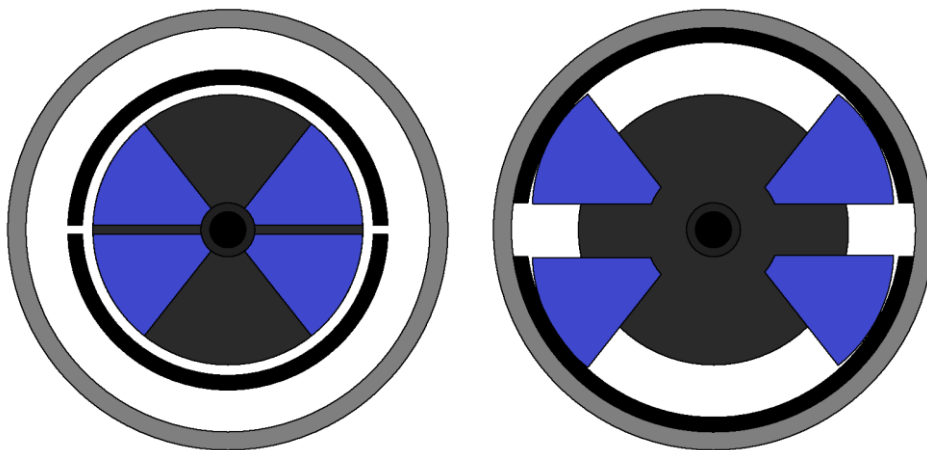

Figure 5-25: Top view – Tubing expansion tool. Left: before expansion. Right: max displacement

5.2.4 Pull Tubing Tool

After cutting and expanding the tubing, a tool to pull the tubing parts together is required. For Each time the tubing parts are pulled together the window increases by 5.5 m, up to a total window gap of 30 m. That means the distance between the tubing parts will vary between 0 and 30 m. The tool would have to be able to be integrated with the other auxiliary tools to be able to have a single-trip tool. A possible solution could be to use a 30 m piston cylinder with anchors latched to the expanded part and the unaltered part. When pressurizing the cylinder the latched anchors would pull the expanded tubing part onto the non-expanded part. In principle an easy solution, but challenges related to controlling the stroke movement of a 30

m piston cylinder and practical challenges related to the size of it, may make it a non-practical solution. Using eight cylinders, each with a 5 m stroke length, linked together would be a similar approach where you achieve the same, but with many smaller cylinders instead of one large. However, there are challenges related to having cylinders linked together, such as controlling each of them individually downhole and design challenges. The best solution may be latch the tool to the expanded section and lower the whole single-trip tool down. When the expanded tubing part is on top of the unaltered part, the tool latches to the unaltered part and pulls the expanded section further downwards. There might be some challenges related to positioning the expanded part in wells with inclination and when the tubing is not in the center of the well, but it may be solved by using tool guides. Pulling the tubing parts together may cause the unaltered tubing part to collapse and thus making the tool stuck. To hinder such event it may be necessary to add a brace on the tool to strengthen the inside of the unaltered tubing part. Figure 5-26 illustrates how the pulling tool may look like.

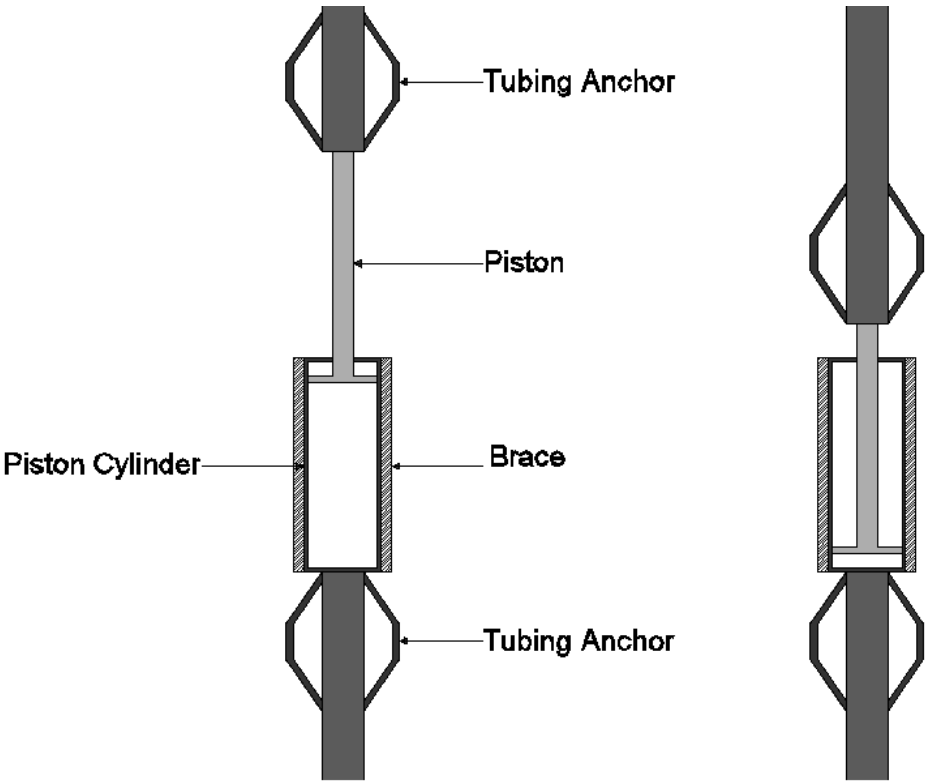

Figure 5-26: Pull Tubing Tool. Left: before pulling. Right: After pulling.

5.2.5 Single Trip Tool

In order for the alternative method to be economically feasible, it may be necessary to have a single-trip tool. That means the auxiliary tools the mechanical cutters, expansion tool and the tubing pull tool are combined into one single tool. Figure 5-27 illustrates how the general tool concept may look like. The electric-mechanical cutting tool is not an omnidirectional cutting tool, meaning it may be necessary to split the cutting into two tool sections, one for the radial cuts and one for the axial cuts. To hinder unwanted axial and radial movement of the tool during operation, hydraulic tubing anchor is proposed to be use between each auxiliary system. The proposed length for each tool section is rough numbers based on existing tools for the tubing anchor [54] and radial cutter [55] and the required minimum length of the other proposed tools.

To keep the number of hydraulic lines required to operate the tool to a minimum, the tool may be designed with one hydraulic input line with 3/2 solenoid valves to control the different piston cylinders and tubing anchors. Appendix G illustrates how the hydraulic schematics of the tool may look like. The hydraulic power could come from either a hydraulic power unit (HPU) located either topside on the vessel or downhole. Using HPU located on the vessel supplying pressurized hydraulic fluid through coiled tubing, with a conductor cable to operate the solenoid valves and the electric-mechanical cutting tools may be natural way to operate the tool. However, using a downhole hydraulic power unit (DHPU) may enable the use an electric line wire, which may reduce the operating cost, compared to using coiled tubing. Typically, the rig up time and operation time is lower by using wireline compared to coiled tubing [13], and thus the cost reduction potential by using DHPU compared to HPU from a vessel may be large. The DHPU may be based on the similar principles as Halliburton's Downhole Power unit [56] where a battery-driven pressure actuator supplies pressurized hydraulic fluid or alternatively by a hydraulic accumulator using compressed nitrogen, pressurizing a reservoir and thus supplying the cylinders with pressurized hydraulic fluid.

Electric line wire typically has a lower breaking strength compared to braided wire due to the electric conductors in the middle. Typical breaking strength for electric line wire is at 23,000N for a 7/32 in. poly cable and 49,000N for a 5/16 in. poly cable [57] and combined with the tool diameter it would the main limitation factors for the tool design.

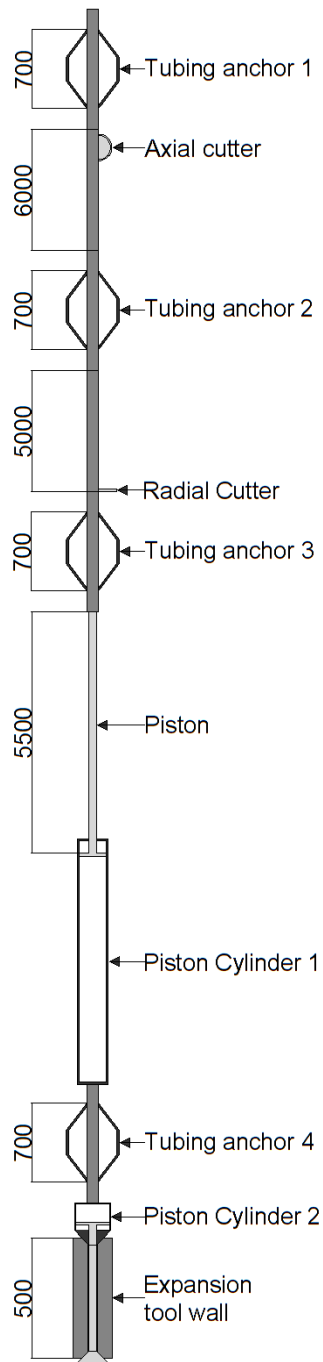

Figure 5-27: single trip tool.

5.2.6 Operational Steps

The operational steps for the tubing expansion method need to be evaluated. This section will describe an operational procedure for how to create a 30 m window downhole. The method is intended for wells, which are presumed to have good cement in place, and the length of the window is set to 30 m to fulfill the minimum required length of logged cement, before setting the secondary plug. By using the data from the FEA without any further optimization, it will

be assumed it is possible to create a window of 5.5 m per tubular length. That means six tubular lengths need to be expanded to gain the necessary window of 30 m. The overall procedure is illustrated on Figure 5-28.

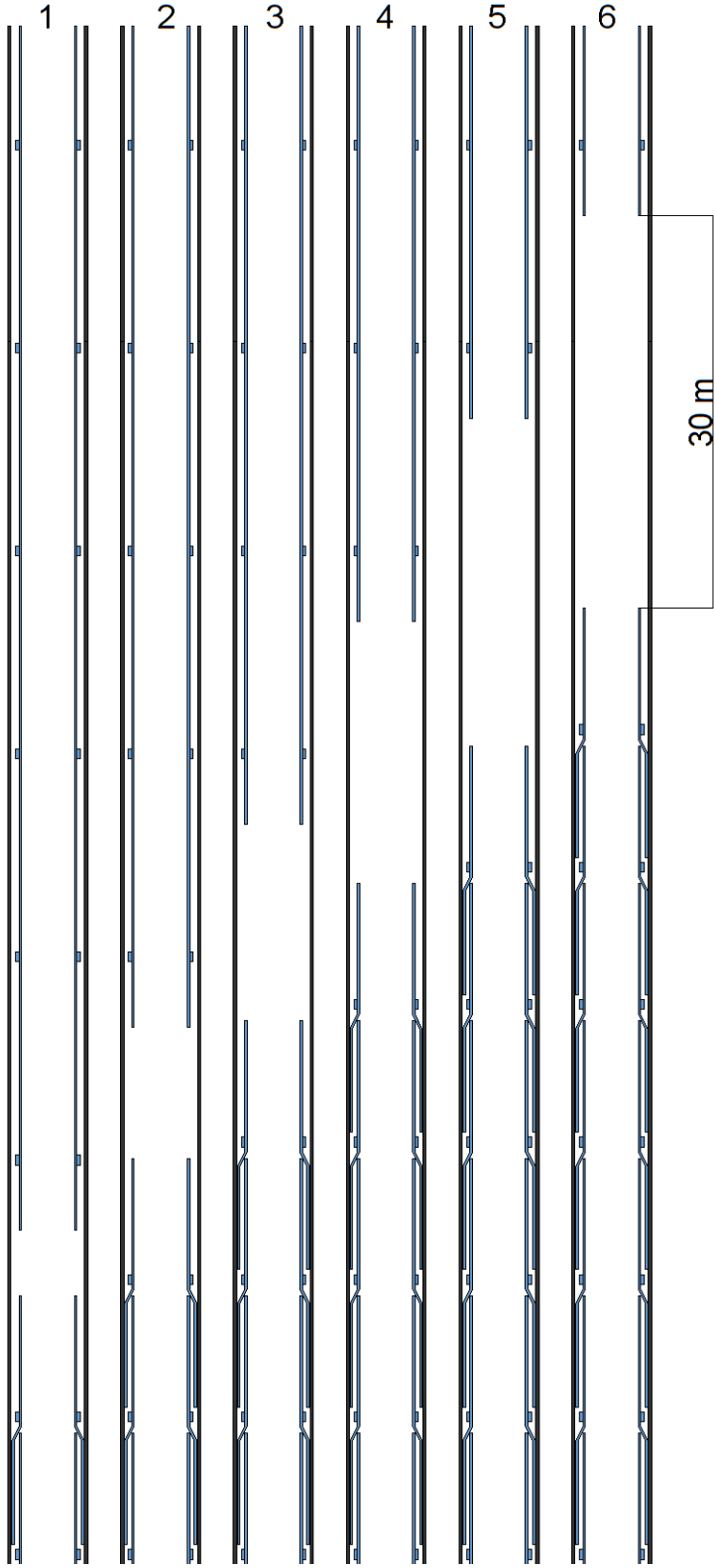

Figure 5-28: Operation procedure.

5.2.6.1 Step One

The first step of the tubing expansion method is to locate the six tubular sections to be expanded. After lowering the single-trip tool in position, tubing anchor 1 and 2 latches to the tubing, illustrated on Figure 5-29. After securing the tool in position, the axial cutter performs the 6.0 m axial cut. After the cut is completed, the tubing anchors unlatches and the single-trip tool is lowered to next tubing sections and the process is repeated until all axial cuts are completed. Performing all the axial cuts at first reduces the need to switch tools during the operation, which may save time. Figure 5-30 illustrates how it may look like after the first step is completed.

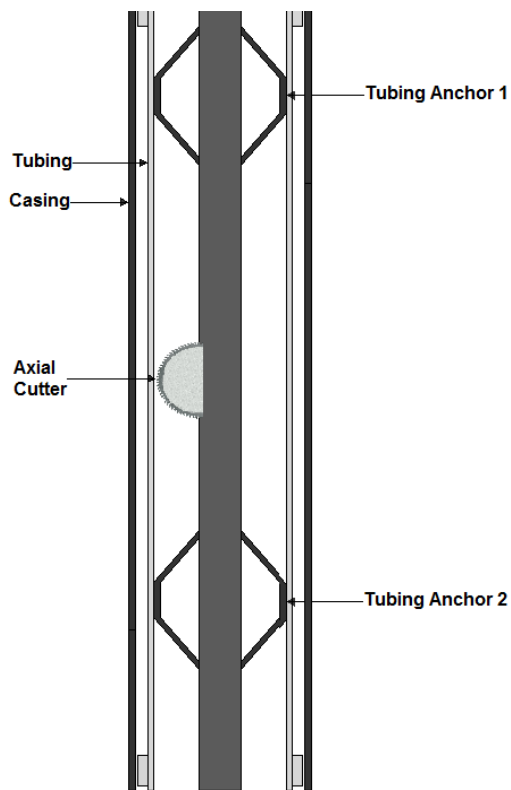

Figure 5-29: Procedure step one: axial cutter

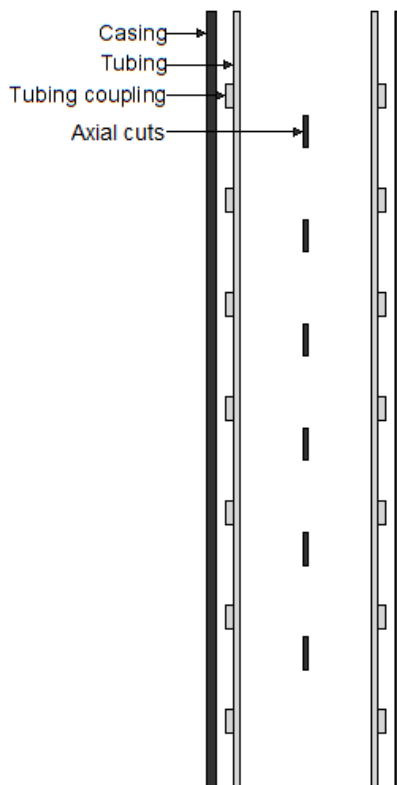

Figure 5-30: Procedure step one: after axial cuts.

5.2.6.2 Step Two

The next step of the procedure is to cut the tubular sections deepest down the well radially, illustrated on Figure 5-31. Tubing anchor two and three latches the tool in position and the radial cutter cuts the radial cut. The cut is to be performed 6.5 m below the top tubing coupling. It may be preferable to perform the cut with an angle to make it easier for the tubing parts to enter in situations where the tubular is not in the center of the well.

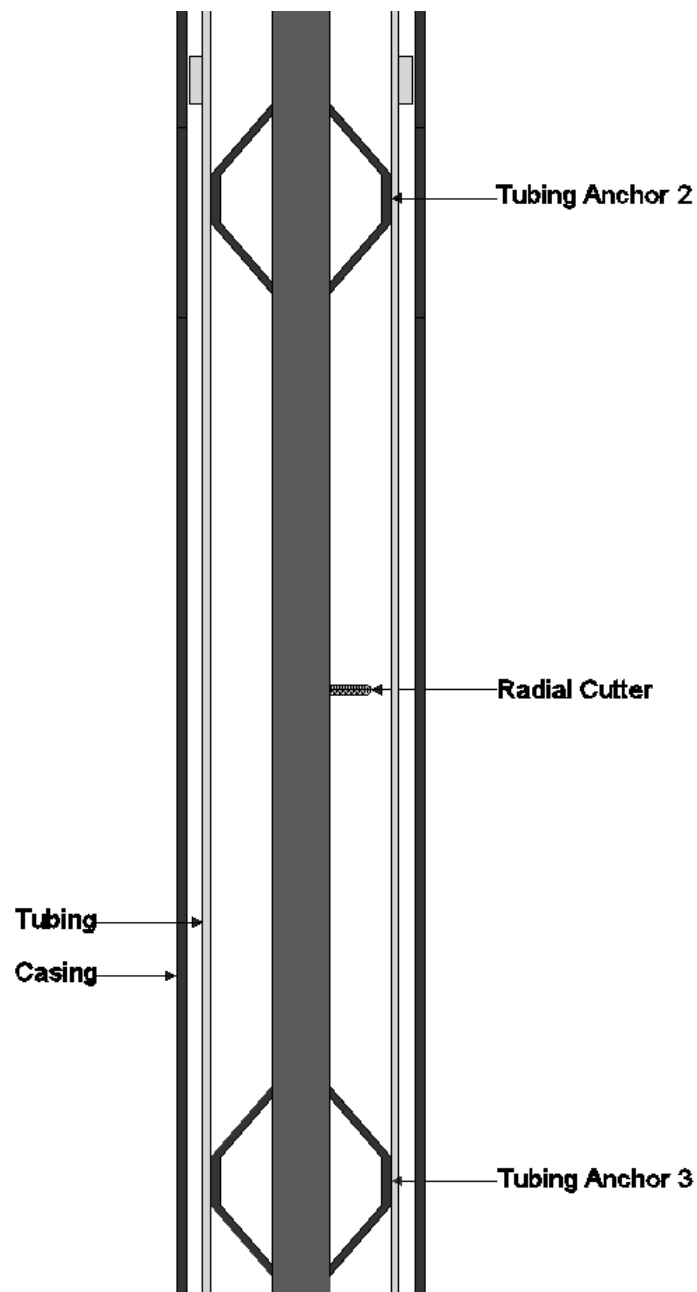

Figure 5-31: Procedure step two: radial cut.

5.2.6.3 Step Three

After tubing anchor 2 and 3 is unlatched from the radial cutting step, the single-trip tool is pulled until the end of the expansion tool is 100 mm inside of the tubing part that is to be expanded. When the expansion tool is in position, tubing anchor 4 latches the tool in place. Pressurizing piston cylinder 2 moves the piston upwards and thus forcing the moveable expansion walls outwards. The force acted upon the tubing from the moveable expansion walls, forces the tubing to expand towards the casing.

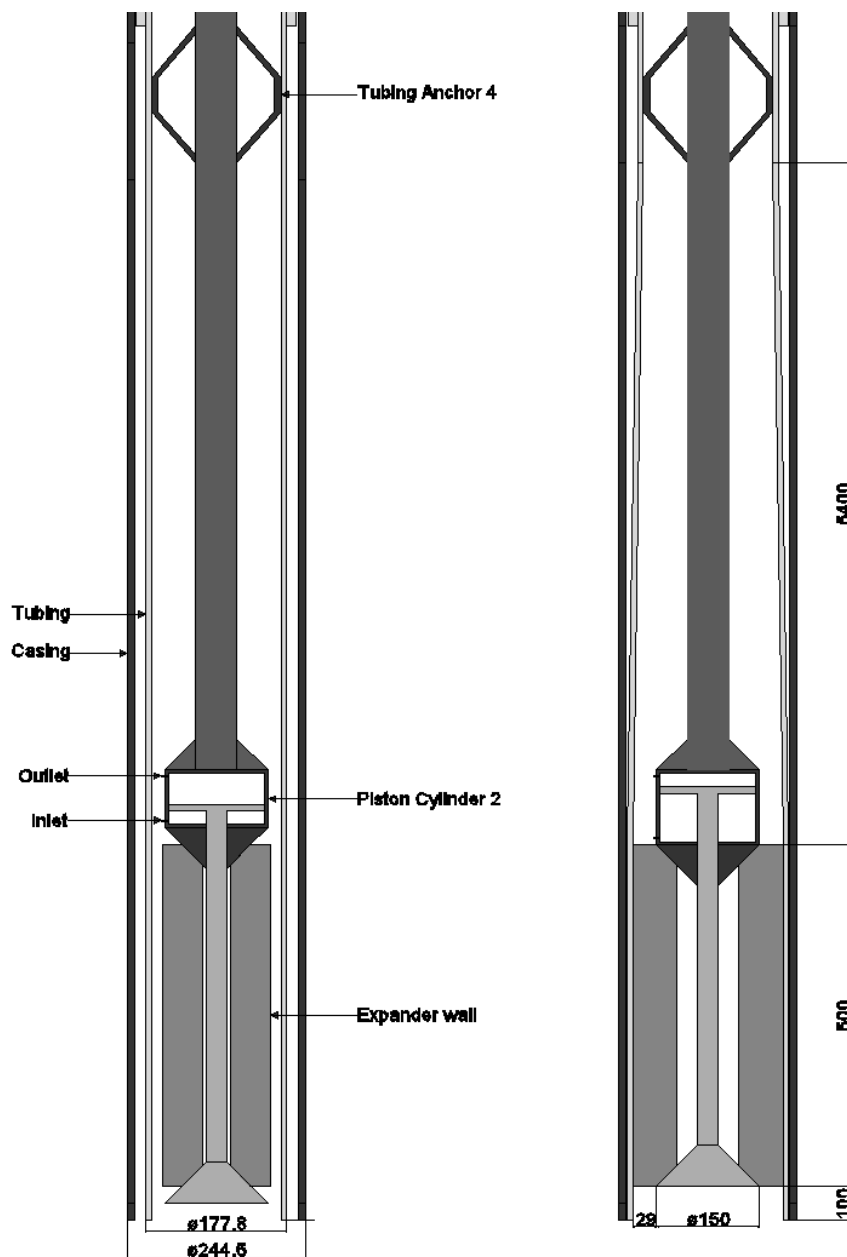

Figure 5-32: Procedure step three, tubing expansion. Left: before expansion. Right: After expansion.

5.2.6.4 Step Four

After the expansion is completed, the single-trip tool performs the radial cut on the next tubing section to free the expanded section. After the cut is performed, the single-trip tool is lowered until with the expansion tool still pressurized. When the expanded and unaltered parts are fitted together, the pressure is released and the tubing anchors are unlatched. The next step is to lower the single-trip tool further, until tubing anchor 3 and 4 can latch to the expanded tubing part and the unaltered tubing part. Pressurizing piston cylinder 1 is after the tubing anchors is latched in place, pulls the tubing parts together and a 5.5 window is created. Figure 5-33 illustrates the process after contact between the tubing parts has been achieved.

After step four is completed, step three and four is repeated until the desired 30 m window length is achieved.

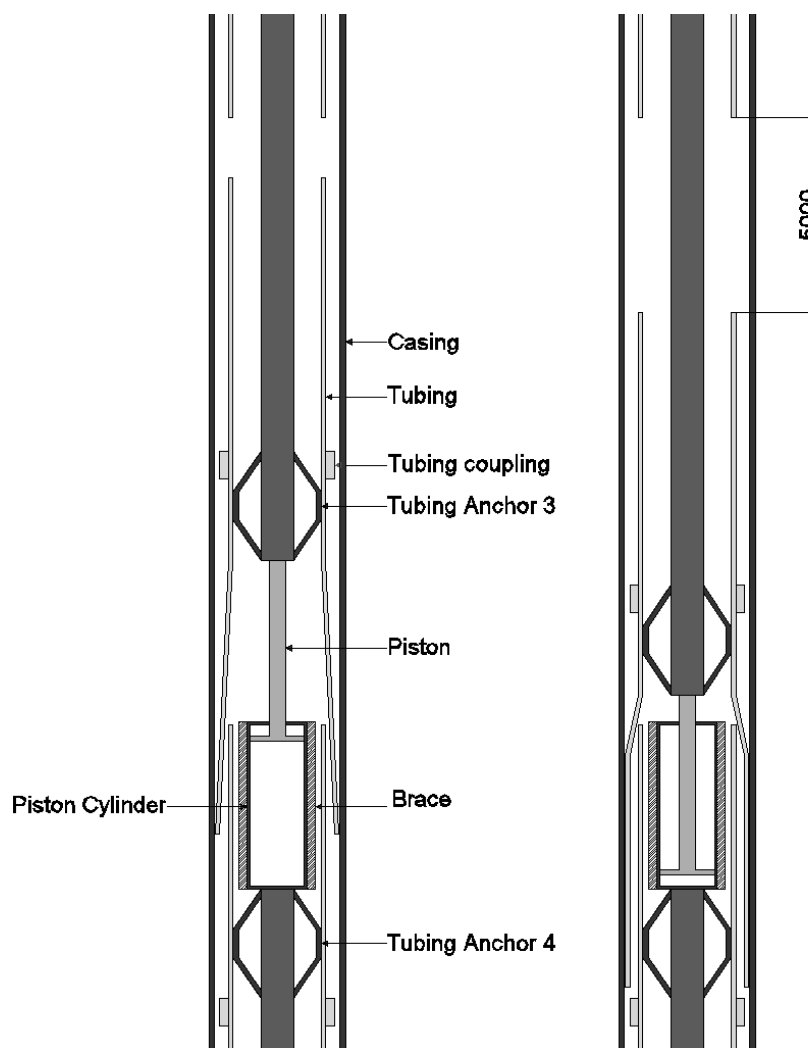

Figure 5-33: Procedure step four, Pull tubing. Left: After tool has been lowered. Right: After pulling.

5.3 Time and Cost Estimation

The proposed procedure consists of many small steps, where each step having the possibility to be performed quickly.

Baker Hughes field test of their electric-mechanical cutting tool performed with 1 mm per minute nominal radial feed rate (adjustable between 0.1 and 20 mm per minute) [50]. By assuming, the cutting operation can be performed with approximately the same speed on 7 in. tubing with a wall thickness of 8.05 mm the cutting speed per radial cut can be assumed to be roughly 8 minutes.

The axial cut is 6.0 m and by assuming the cutting speed is equal to radial cut per mm, time per axial can be calculated from equation 5.4, which gives 86 minutes.

$$t = \frac{l_{axial\ cut}}{\pi OD_{tubing}} t_{radial\ cut} \quad (5.4)$$

The time it takes to expand the tubing and pull the tubing parts together can in theory in be done quickly where the main time consumer would be latching the tubing anchors in correct position. More details regarding the tools would be required to be more exact in terms of time per operation, however it will be assumed to take approximate 15 minutes per operations.

With 8 minutes per radial cut, 86 minutes per axial cut and 15 minutes per expansion and pulling operation, it will take approximately 210 minutes to perform one operation cycle when two axial cuts is required. With six operation cycles to gain a minimum of 30 m window the total operation time will be approximately 1260 minutes (21 hours).

To check if the method is economical feasible, the operational time will be compared to pulling the tubing from a semi-submersible drilling rig and from a LWIV. Pulling the tubing from a LWIV has not yet been performed, but it is technological feasible [31]. The LWIV may have limited deck space to store the tubing during a plug and abandonment operation. The tubular would therefore have to be either stored on a barge/platform supply vessel (PSV) or wet-stored on the seabed in bundles and later be picked up by an inspection, maintenance and repair (IMR) vessel. For easier cost estimations, it will be assumed the tubing is stored on a PSV. It will be assumed the semi-submersible drilling can store the tubular on deck. Cost

related to deploying equipment, vessel traveling to site, weather effects and equipment investment cost will be assumed similar.

The average daily operating cost of a semi-submersible drilling rig is 2.5m NOK (\$424,000) per day [3], while an LWIV is approximately 860,000 NOK per day [58] and a PSV 200,000 NOK (\$35,000) per day [59]. The tubing pulling speed will be assumed 200 m / hour [30] for both the LWIV and semi-submersible drilling rig. By assuming there is no restriction on well length for neither of the options the cost compared to using a semi-submersible drilling rig can be found from equation 5.5 while cost compared to pulling the tubing from a LWIV can be found from equation 5.6.

$$(\text{Cost LWIV})(\text{Tubing expansion method}) = (\text{Rig cost}) \frac{(\text{Tubing pulling length})}{(\text{pulling speed})} \quad (5.5)$$

$$(\text{Cost LWIV})(\text{Tubing expansion method}) = (\text{LWIV+PSV cost}) \frac{(\text{Tubing pulling length})}{(\text{pulling speed})} \quad (5.6)$$

By solving the cost estimation with tubing pulling length as unknown, the tubing expansion method will be economically feasible for pulling lengths greater than 1445 m compared to pulling by a semi-submersible and 3407 m by LWIV.

5.4 Discussion

The alternative method, tubing expansion with axial cuts has been investigated through an FE-analysis with one, two and four axial cuts, operational aspects of the method in terms of tool design and procedure and a time and cost estimation.

The starting point for the method was to check feasibility by doing an FEA analysis on 7 in. tubing with one axial cut, which illustrated more a need for more symmetric expansion. Two axial cuts illustrated it needed a large force to deform the tubing plastically in x-direction (around the cuts). To compensate for that it was performed FEA on 2 axial cuts with pressure only around the cuts. The results illustrated it was a preferred method to expand the tubing with and different scenarios were tested. To deform the tubing plastically enough for it to fit around the unaltered tubing part, a larger force than expected was required in radial direction. The analysis illustrated therefore the expansion tool will have to be pressurized until the tubing parts are fitted together. The required force to expand the tubing is much lower than to plastically deform it and made tool choices easier, but at a cost of a more complex operation.

To confirm the FEA, laboratory experiments would be required to perform. More analysis work is also recommended to be performed on different tubing and casing sizes and material grades, to find if an all-round tool for all scenarios is possible achieve or if the tool has to be unique for each well.

Many wells have control lines attached to the tubing. The impact these lines has on the on the method has not been looked upon. It may be a potential problem by affecting the amount the tubing can be expanded in x and z direction. The effects the control lines have on the expansion would have to be investigated along challenges such as smaller annulus to check if there are any limitations to scenarios where the method is not feasible.

Operational aspects of implementing the tubing expansion with axial cuts were also investigated. The premise for the investigation was the method would not be feasible if it the method required multiple trips. The possibilities to use a single-trip tool were therefore investigated. The proposed the single-trip tool consisted of four tubing anchors, one axial electric-mechanical cutter, one radial electric-mechanical cutter, one piston cylinder for pulling tubing parts together and one piston cylinder connected to expansion walls. The

proposed auxiliary tool solutions are all based on either hydraulic or electric power. The use of hydraulic power may limit the tool to coiled tubing, and thus increasing the cost. The proposed idea with using a downhole hydraulic power unit may enable the use of wireline instead of coiled tubing, and thus reduce the operating cost of the method. The downside is however, increase tool complexity, increased tool investment cost and possible higher operation risk, meaning a further investigation would have to be performed to understand the impact having a downhole hydraulic power supply would have and compare it towards a operation performed by coiled tubing.

Having many tools connected together as proposed may create a rather long tool, but the length itself may not be an issue. A high total tool weight would make it hard to use common wireline equipment. As mentioned earlier the breaking strength for an electric 5/16 in. poly cable is 49,000 N, which would be the limiting weight factor for the tool. Detailed engineering design of the tool has not been performed and the current design would have to be reinforced to withstand for example uneven loading from lowering the tool in inclined wells and general tool handling. However, it is not expected that the weight will be an issue due major parts of the single-trip tool can be designed with low weight as a parameter with light weighted materials. Large parts of the tool length consists hydraulic operated piston cylinders, which is filled with hydraulic fluid. Hydraulic fluid has lower density than the completion fluids used in the well and thus generate some positive buoyancy that may reduce some force acting upon the wire.

The max diameter the tool would also have to be investigated further. Lowering a long tool in wells with inclination may get them stuck, if it has not been adjusted for inclination. It is also likely that wells ready to be plugged and abandoned has deposits of scale and/or asphaltenes on the inside of the tubing. It would therefore be necessary to set a max diameter based on the tubing drift diameter and a safety margin based on factors such as expected scale deposits, well inclination and tool length.

To perform the cutting operation it was proposed to use an electric-mechanical cutting tool due to having high reliability and easy to integrate with the rest of the tool. The downside of the choice can however be seen with the time estimation per axial cut. It may be necessary to investigate further the available options to perform the axial cuts, to look for means to reduce the cutting time. An option that would be worth investigating further would be to use multiple

axial cutters operating at the same time. By having two axial cutters operating at the same time, the total operating time would be reduced to 12.4 hours and thus making the method very viable compared to traditional methods.

The auxiliary system of the single-trip tool, the expansion system is based on typical exhaust pipe expansion tools powered by hydraulic instead of force generated from a wrench. It would be necessary to confirm the general tool design through a laboratory test to see how it performs, and look for ways to optimize the design. An FE-analysis would also be necessary to perform, to find weak spots in the design. Especially the end parts of the rod may experience large amount of stress during the expansion, which may limit the force output the tool can generate.

The auxiliary tool, pulling the tubing parts together, is in all simplicity a piston cylinder and anchors to hold the parts during the axial movement. Generating axial force downhole is easier than generating radial force due to it naturally being more space in the axial direction. Implementing a typical piston cylinder used for example during setting of packers, bridge plugs or other downhole equipment may be possible. An FE-analysis of the contact between the expanded- and unaltered tubing part was attempted to set requirements for the piston cylinder, but due to convergence issues, it has not been included. The unconverged solution suggested the unaltered tubing part might experience large deformation. Since it would be critical to avoid large inwards deformation on the unaltered tubing part to avoid the tool being stuck, it has been proposed to add a brace on the auxiliary tool to strengthen the inside of the tubing during the operation.

The method was estimated to be economically feasible for tubing pull lengths over 1445 m for cases where a semi-submersible drilling rig is used and 3407 m where the alternative is LWIV. It is to be noted that pulling the tubing from a LWIV has not been done yet and was included because the industry has a high focus on enabling pulling the tubing from a LWIV. On N.C.S, the well length is typically up to 3000 m, which would imply that pulling from LWIV is a better solution than the expansion with axial cut method. However, there are uncertainties in the calculations and more factors needs to be included to give a better cost picture. For example, the cost of handling and disposal of the tubing has not been included and the tubing expansion method can be performed with a Category A vessel while pulling the tubing may require the use of the larger and the more expensive, Category A++. There are

also additional factors such as HSE, which should be included in the calculations. There are also huge potentials by improving the axial cutting method and for example by having two axial cutters working simultaneously the breakeven point would be 2304 m with similar calculations. By just comparing the method to pulling with a semi-submersible drilling rig the alternative method shows potential to cut cost and especially with a faster axial cutting method.

How the alternative method affects other part of the P&A operation has not been investigated. The method may under some circumstances have a negative impact on setting the open hole to surface plug due to having an extra tubular to pull. It may however be a cheaper solution overall by reducing the total amount of time the drilling rig is on site. The current industry practice with large P&A campaigns is to use a semi-submersible drilling rig to set the plugs and a LWIV to cut and pull the conductor and surface casing. The LWIV is capable of setting the reservoir plug which means it may be possible for P&A campaigns to use a LWIV to set the reservoir plug, create a 30 m window gap with the tubing expansion with axial cuts method, log the cement behind the casing, and if the cement is good set the secondary plug. The drilling rig could do the next phase of the P&A operation, setting the open hole to surface plug and cut and pull the conductor and surface casing. In cases where the log reveals poor cement the LWIV could for example set a temporary plug and the drilling rig could perform section milling when it got on site.

6 Conclusion

- Alternative methods for tubing removal were compared to conventional methods. An evaluation of the alternative methods was performed and suggested tubing expansion with axial cuts should be further investigated.
- FE-analysis suggested two cuts with pressure around the cut area is the preferred way to perform the expansion.
- Operational steps and tools necessary to perform the alternative method were investigated. It was found that electric-mechanical cutters could perform the cutting process, the expansion process by a tool based on similar principles as a pipe exhaust tool and pulling the tubing parts together by a regular piston cylinder.
- Time estimation indicated the tubing expansion with axial method would take approximately 21 hours.
- Cost estimation suggested the alternative method is economical feasible when the alternative is to pull more than 1445 m tubing by semi-submersible drilling rig and 3407 m by LWIV.
- Further work regarding making the method more efficient is recommended. Especially in regards to lower the time, it takes to perform the axial cutting operation.

6.1 Further Work

- Laboratory experiments to confirm the FE-analysis.
- Investigate the impact pulling the tubing together has on the unaltered part and the required cylinder pressure to achieve the desired pulling length.
- Investigate expansion on 5 in. tubing.
- Investigate the impact reducing the casing size and different material grades have.
- Investigate the impact control lines have.
- Investigate the feasibility of using multiple axial cutters.
- Perform a more detailed time analysis to verify cost saving, with focus on impacts the method has on other parts of the plug and abandonment operation.

References

- [1] M. Straume, "Plug and Abandonment Forum (PAF)," Plug & Abandonment Forum (PAF), 13 June 2013. [Online]. Available: <http://www.norskoljeoggass.no/Global/Presentasjoner/PAF%20seminar2013/1%20-%20PAF%20-%20Martin%20Straume.pdf>. [Accessed 9 May 2014].
- [2] Statoil, "Closed 1. February 2012 - Plug and Abandonment," [Online]. Available: <http://innovate.statoil.com/challenges/Pages/PlugAndAbandonment.aspx>. [Accessed 29 May 2014].
- [3] RIGZONE, "Offshore Rig Day Rates," RIGZONE, 28 May 2014. [Online]. Available: <http://www.rigzone.com/data/dayrates/>. [Accessed 28 May 2014].
- [4] A. T. Bourgoyne, K. K. Milheim, M. E. Chenevert and F. S. Young, Applied drilling engineering, Society of Petroleum Engineers , 1986.
- [5] NORSOK Standard, "D-10," standard.no, 2013.
- [6] Schlumberger, "Conductor Pipe," [Online]. Available: <http://www.glossary.oilfield.slb.com/en/Terms.aspx?LookIn=term%20name&filter=conductor%20pipe>. [Accessed 25 May 2014].
- [7] Schlumberger, "Surface Casing," [Online]. Available: <http://www.glossary.oilfield.slb.com/en/Terms.aspx?LookIn=term%20name&filter=surface+casing>. [Accessed 25 May 2014].
- [8] Schlumberger, "Intermediate Casing String," [Online]. Available: <http://www.glossary.oilfield.slb.com/en/Terms.aspx?LookIn=term%20name&filter=intermediate+casing> . [Accessed 25 May 2014].
- [9] Schlumberger , "Production Casing," [Online]. Available: <http://www.glossary.oilfield.slb.com/en/Terms.aspx?LookIn=term%20name&filter=production+casing>. [Accessed 25 May 2014].
- [10] Schlumberger, "Liner," [Online]. Available: <http://www.glossary.oilfield.slb.com/en/Terms/l/liner.aspx>. [Accessed 25 May 2014].
- [11] API Standard, "5CT - Specification for Casing and Tubing," American Petroleum Institute, 2011.
- [12] Statoil, "Illustration: Category A, B and C (Modified)," [Online]. Available: <http://www.npd.no/Global/Norsk/3-Publikasjoner/Norsk-sokkel/Nr.3-2009/Bilder/Plattform-side-11.jpg>.
- [13] S. Sangesland, "Subsea Well Intervention," NTNU, Course material TPG4200 Subsea production Systems, Trondheim, 2010.

- [14] Statoil, "Rig Strategy," 26 October 2012. [Online]. Available: <http://www.statoil.com/en/technologyinnovation/technologymanagement/pages/statoils%20riggstrategi.aspx>. [Accessed 30 May 2014].
- [15] Helix ESG, "Well Intervention Overview," [Online]. Available: <http://www.sec.gov/Archives/edgar/data/866829/000086682912000026/exh992.htm>. [Accessed 30 May 2014].
- [16] T. Ferg, "Developments in Non-Traditional Plug and Abandonment Methods," 13 June 2013. [Online]. Available: <http://www.norskoljeoggass.no/Global/Presentasjoner/PAF%20seminar2013/4%20-ConocoPhillips-Thomas%20Ferg.pdf>. [Accessed 28 May 2014].
- [17] J. O. Nessa, "Setting plug & abandonment barriers with minimum removal of tubulars," Master thesis, Faculty of Science and Technology, UiS, Stavanger, 2012.
- [18] Statoil, "Plug and Abandonment Challenges," [Online]. Available: <http://www.slideshare.net/Statoil/plug-abandonment>. [Accessed 27 November 2013].
- [19] F. Moeinikia, A. Saasen, S. Raksagati, K. K. Fjelde and T. Vrålstad, "SPE," 10 April 2013. [Online]. Available: http://bergen.spe.no/publish_files/GJ-5-SPE_Bergen_Seminar.pdf. [Accessed 28 May 2014].
- [20] C. Stowe and A. Ponder, "Performance Advance in Section Milling Technology," *SPE*, vol. 145957, 2011.
- [21] T. E. Ferg, H.-J. Lund, D. Mueller, M. Myhre, A. Larsen, P. Andersen, G. Lende, C. Hudson, C. Prestegaard and D. Field, "Novel Approach to More Effective Plug and Abandonment Cementing Techniques," *SPE*, vol. 148640, 2011.
- [22] Njå and N. O. Berg, "P&A of Valhall DP wells," UIS, Faculty of Science and Technology - Master's Thesis, Stavanger, 2012.
- [23] HydraWell, "HydraWash," [Online]. Available: <http://hydrawell.no/products/hydrawash>. [Accessed 25 May 2014].
- [24] Subsea P&A As, "Norsk Olje og Gass," June 2011. [Online]. Available: <https://www.norskoljeoggass.no/PageFiles/10706/9%20NCA%20Solutions%20for%20Subsea%20PA.pdf?epslanguage=no>. [Accessed 8 March 2014].
- [25] Statoil, "Norsk Olje og Gass," 14 June 2012. [Online]. Available: <http://www.norskoljeoggass.no/Global/Presentasjoner/PAF%20Workshop/11%20-%20Statoil%20-%20Svein%20Vatna.pdf>. [Accessed 9 March 2014].
- [26] A. Saasen, K. K. Fjelde, T. Vrålstad, S. Raksagati and F. Moeinikia, "Plug and Abandonment of Offshore Exploration Wells," in *Offshore Technology Conference*, Houston, 2013.

- [27] Wellbarrier, "ICRARD," 21 November 2012. [Online]. Available: <http://www.icrard.org/Documents/Plug%20and%20abandonment%20of%20wells%20external%20rev%201.pdf>. [Accessed 8 March 2014].
- [28] S. Sætre, "Analysis of Alternative Methods for Cutting Downhole Tubing," Specialization Project, NTNU, 2013.
- [29] oilfield Innovations Ltd, "New Technology Product Launch," 2012. [Online]. Available: <http://www.oilfieldinnovations.com/wp-content/uploads/2011/05/Oilfield-Innovations-Brochure.pdf>. [Accessed 28 May 2014].
- [30] M. B. L. Valdal, "Plug and Abandonment Operations Performed Riserless using a Light Well Intervention Vessel," UiS, Faculty of Science and Technology, 2013.
- [31] P. Buset, "Plugging & abandonment of subsea completed wells - can this be done from a mono-hull vessel?," 18 April 2013. [Online]. Available: <http://www.spe-uk.org/aberdeen/knowledgefiles/09%20Buset%20Island%20Offshore.pdf>. [Accessed 8 May 2014].
- [32] R. Stewart, F. Marketz, W. Lohbeck, F. Fischer, W. Daves, F. Rammerstorfer and H. Böhm, "Expandable Wellbore Tubulars," in *SPE Technical Symposium "Quest for Solutions in a Changing Industry"*, Dhahran, Saudi Arabia, 1999.
- [33] W. Renpu, *Advanced Well Completion Engineering*, Elsevier Gulf Professional Publishing, 2011.
- [34] E. Madenci and I. Guven, *The Finite Element Method and Applications in Engineering Using ANSYS*, Springer, 2006.
- [35] ANSYS, «ANSYS 14.5 Help».
- [36] ANSYS, "Introduction to Contact," December 2010. [Online]. Available: http://inside.mines.edu/~apetrell/ENME442/Labs/1301_ENME442_lab6_lecture.pdf. [Accessed 14 May 2014].
- [37] ANSYS, "ANSYS Online manual Release 5.5 - Chapter 2: Loading," [Online]. Available: http://mostreal.sk/html/guide_55/g-bas/GBAS2.htm. [Accessed 29 May 2014].
- [38] WARDjet, "How waterjet cutting works," [Online]. Available: <http://www.wardjet.com/03-how-it-works.html>. [Accessed 20 May 2014].
- [39] D. G. Alberts and M. Hashish, "Evaluation of submerged High-Pressure waterjets for deep ocean," *International Offshore and Polar Engineering Conference*, no. ISBN: 1-880653-22-2, 1996.
- [40] J. J. R. Jegaraj and N. R. Babu, "A soft computing approach for controlling the quality of cut with abrasive waterjet cutting system experiencing orifice and focusing tube wear," *Journal of*

Materials Processing Technology, no. 185, pp. 217-227, 2007.

- [41] W. Manfred, "Liquid-Solid Flow," 7 September 2010. [Online]. Available: <http://www.thermopedia.com/content/51/?tid=104&sn=1297>. [Accessed 3 June 2014].
- [42] Jurgens and M.S., "Effect of Well Variables on the Performance of Chemical, Jet and RCT Tubing Cutters," in *SPE Annual Technical Conference and Exhibition*, Anaheim, California, U.S.A, 2007.
- [43] Petrowiki, "Pipe cutoff methods," [Online]. Available: http://petrowiki.org/Pipe_cutoff_methods. [Accessed 16 May 2014].
- [44] Schlumberger, "PowerCutter - Precision Tubular Cutter," [Online]. Available: http://www.slb.com/~media/Files/perforating/brochures/powercutter_br.pdf. [Accessed 16 May 2014].
- [45] SPEX, "Explosive products," [Online]. Available: <http://www.spex-innovation.com/spex-offshore/products/explosives/>. [Accessed 16 May 2014].
- [46] GE-Energy, "Downhole Electric Cutting Tool (DECT001)," [Online]. Available: http://www.ge-energy.com/products_and_services/products/wireline_systems/downhole_electric_cutting_tool.jsp. [Accessed 16 May 2014].
- [47] Baker Hughes, "Mechanical Pipe Cutter (MPC)," [Online]. Available: <http://www.bakerhughes.com/products-and-services/evaluation/cased-hole-wireline-systems/pipe-recovery/mechanical-pipe-cutter-mpc>. [Accessed 16 May 2014].
- [48] Aker Solutions, "Downhole Electrical Cutting tool - DECT001," [Online]. Available: <http://www.akersolutions.com/Global/Subsea/Aker%20Well%20Service/Logging/DECT%20-%20Downhole%20Electric%20Cutting%20Tool.pdf>. [Accessed 16 May 2014].
- [49] J. F. Cole, "Pyro Technology for Cutting Drill Pipe and Bottomhole Assemblies," in *SPE/IADC Drilling Conference*, Amsterdam, Holland, 1999.
- [50] O. Fanini, K. Fuhst, D. Cousin, M. Moeller, M. A. Ahmed, B. Ross, K. S., P. Lawson and S. M. Cattanach, "Field Test Results of an Electromechanical Precision Pipe-Cutting Tool," in *SPE Annual Technical Conference and Exhibition*, New Orleans, Louisiana, USA, 2009.
- [51] S. Wilson, Z. Erkol, A. Faugere, B. Eatwell, F. Espinosa and R. Xu, "Inflatable Packers in Extreme Environments," in *SPE/ICoTA Coiled Tubing Conference and Exhibition*, Houston, Texas, U.S.A, 2004.
- [52] Weatherford, "Inflatable Packers," [Online]. Available: http://spepgh.weebly.com/uploads/3/5/4/2/3542131/inflatable_packers_30apr2013-spe_ne.pdf. [Accessed 18 May 2014].

- [53] Autozone, "OEM/2 1/8 in. tail pipe expander," [Online]. Available: http://www.autozone.com/autozone/accessories/OEM-2-1-8-in-tail-pipe-expander/_/N-25fc?itemIdentifier=110585_0_0_. [Accessed 19 May 2014].
- [54] Wellvention, "Hydraulic Tubing Anchor-1," [Online]. Available: <http://www.wellvention.com/productinfo/hydraulic-tubing-anchor-1>. [Accessed 27 May 2014].
- [55] Baker Hughes, "Mechanical Pipe Cutter Tool," [Online]. Available: http://assets.cmp.bh.mxcloud.com/system/88ad8c67d215f5d8ad3263b0ca2392ae_28512-mpc_po-0810_lr.pdf. [Accessed 27 May 2014].
- [56] Halliburton, "Downhole Power Unit (DPU) - Interlligent Series Tool," [Online]. Available: http://www.halliburton.com/public/lp/contents/Data_Sheets/web/H/H06387.pdf. [Accessed 4 June 2014].
- [57] J. Wright, "An Introduction to Well Intervention," 25 January 2011. [Online]. Available: <http://www.spe-uk.org/aberdeen/knowledgefiles/JimWright-SPEAberdeenJanuarypresentation.pdf>. [Accessed 4 June 2014].
- [58] Island Offshore, "Investor presentation," 19 February 2014. [Online]. Available: <http://www.islandoffshore.com/?c=36372>. [Accessed 28 May 2014].
- [59] Westshore - Shipbrokers AS, "Fixtures - Term - 08/04/2014 MAERSK TRACER - Saipem Italy - Assist Castoro Sei, 40 days firm + opt - USD 35000," 28 May 2014. [Online]. Available: westshore.no. [Accessed 28 May 2014].
- [60] M. C. P. Selvan and N. M. S. Raju, "Assessment of process parameters in abrasive waterjet cutting of stainless steel," *International Journal of Advances in Engineering & Technology*, vol. 2011, no. ISSN: 2231-1963, 2011.
- [61] Peter, Dirk, "European website on Decommissioning of Nuclear Installations," 19 October 2005. [Online]. Available: http://www.eu-decom.be/network/eundetrafr/pdf/Session8_Dismantling%20Techniques_presentationUniH.pdf. [Accessed 28 May 2014].
- [62] O. Bratland, Pipe Flow 1 - Single-phase Flow Assurance, 2009.

Appendix A: Tubing Stress Expansion

Table A - 1: 5 in. Tubing stress expansion

OD	Grade	Wall thickness	ID	Material hardening index	Max achievable expansion	Expansion needed	Expansion possible
(mm)		(mm)	(mm)		(%) (mm)	(mm)	
139.70	H-40	6.20	127.30	0.14	15.03 19.13	12.40	True
139.70	J-55	6.20	127.30	0.12	12.75 16.23	12.40	True
139.70	J-55	6.99	125.73	0.12	12.75 16.03	13.97	True
139.70	J-55	7.72	124.26	0.12	12.75 15.84	15.44	True
139.70	K-55	6.20	127.30	0.12	12.75 16.23	12.40	True
139.70	K-55	6.99	125.73	0.12	12.75 16.03	13.97	True
139.70	K-55	7.72	124.26	0.12	12.75 15.84	15.44	True
139.70	L-80	7.72	124.26	0.10	10.52 13.07	15.44	False
139.70	L-80	9.17	121.36	0.10	10.52 12.76	18.34	False
139.70	L-80	10.54	118.62	0.10	10.52 12.48	21.08	False
139.70	N-80	7.72	124.26	0.10	10.52 13.07	15.44	False
139.70	N-80	9.17	121.36	0.10	10.52 12.76	18.34	False
139.70	N-80	10.54	118.62	0.10	10.52 12.48	21.08	False
139.70	C-90	7.72	124.26	0.10	10.52 13.07	15.44	False
139.70	C-90	9.17	121.36	0.10	10.52 12.76	18.34	False
139.70	C-90	10.54	118.62	0.10	10.52 12.48	21.08	False
139.70	C-90	12.09	115.52	0.10	10.52 12.15	24.18	False
139.70	C-90	16.51	106.68	0.10	10.52 11.22	33.02	False
139.70	C-95	7.72	124.26	0.09	9.42 11.70	15.44	False
139.70	C-95	9.17	121.36	0.09	9.42 11.43	18.34	False
139.70	C-95	10.54	118.62	0.09	9.42 11.17	21.08	False
139.70	P-110	7.72	124.26	0.08	8.33 10.35	15.44	False
139.70	P-110	9.17	121.36	0.08	8.33 10.11	18.34	False
139.70	P-110	10.54	118.62	0.08	8.33 9.88	21.08	False

Table A - 2: 7 in. Tubing stress expansion

OD (mm)	Grade	Wall thickness (mm)	ID (mm)	Material hardening index	Max achievable expansion (%)	Expansion needed (mm)	Expansion possible	
177.80	H-40	5.87	166.07	0.14	7.25	12.04	11.73	True
177.80	H-40	6.91	163.98	0.14	7.25	11.89	13.82	False
177.80	J-55	6.91	163.98	0.12	6.18	10.14	13.82	False
177.80	J-55	8.05	161.70	0.12	6.18	10.00	16.10	False
177.80	J-55	9.19	159.41	0.12	6.18	9.86	18.39	False
177.80	K-55	6.91	163.98	0.12	6.18	10.14	13.82	False
177.80	K-55	8.05	161.70	0.12	6.18	10.00	16.10	False
177.80	K-55	9.19	159.41	0.12	6.18	9.86	18.39	False
177.80	L-80	8.05	161.70	0.10	5.13	8.29	16.10	False
177.80	L-80	9.19	159.41	0.10	5.13	8.17	18.39	False
177.80	L-80	10.36	157.07	0.10	5.13	8.05	20.73	False
177.80	L-80	11.51	154.79	0.10	5.13	7.94	23.01	False
177.80	L-80	12.65	152.50	0.10	5.13	7.82	25.30	False
177.80	L-80	13.72	150.37	0.10	5.13	7.71	27.43	False
177.80	N-80	8.05	161.70	0.10	5.13	8.29	16.10	False
177.80	N-80	9.19	159.41	0.10	5.13	8.17	18.39	False
177.80	N-80	10.36	157.07	0.10	5.13	8.05	20.73	False
177.80	N-80	11.51	154.79	0.10	5.13	7.94	23.01	False
177.80	N-80	12.65	152.50	0.10	5.13	7.82	25.30	False
177.80	N-80	13.72	150.37	0.10	5.13	7.71	27.43	False
177.80	C-90	8.05	161.70	0.10	5.13	8.29	16.10	False
177.80	C-90	9.19	159.41	0.10	5.13	8.17	18.39	False
177.80	C-90	10.36	157.07	0.10	5.13	8.05	20.73	False
177.80	C-90	11.51	154.79	0.10	5.13	7.94	23.01	False
177.80	C-90	12.65	152.50	0.10	5.13	7.82	25.30	False
177.80	C-90	13.72	150.37	0.10	5.13	7.71	27.43	False
177.80	C-95	8.05	161.70	0.09	4.60	7.44	16.10	False
177.80	C-95	9.19	159.41	0.09	4.60	7.34	18.39	False
177.80	C-95	10.36	157.07	0.09	4.60	7.23	20.73	False
177.80	C-95	11.51	154.79	0.09	4.60	7.12	23.01	False
177.80	C-95	12.65	152.50	0.09	4.60	7.02	25.30	False
177.80	C-95	13.72	150.37	0.09	4.60	6.92	27.43	False
177.80	P-110	9.19	159.41	0.08	4.08	6.51	18.39	False

177.80	P-110	10.36	157.07	0.08	4.08	6.41	20.73	False
177.80	P-110	11.51	154.79	0.08	4.08	6.32	23.01	False
177.80	P-110	12.65	152.50	0.08	4.08	6.22	25.30	False
177.80	P-110	13.72	150.37	0.08	4.08	6.14	27.43	False

Appendix B: Force required to displace tubing

Beam with cantilever support

Assumption:

- The expansion of the tubing with two axial cuts can be calculated equal to a beam with cantilever support with moment of inertia equal to half a hollow cylinder.
- Cantilever beam with uniformly distributed load is assumed equal to a concentrated load, F at the center of the uniformly distributed load with equal total force.

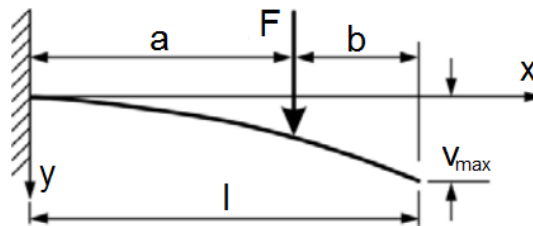

Figure B- 1: Cantilever Beam.

$$OD_{\text{tubing}} = 177.8\text{mm}$$

$$ID_{\text{tubing}} = 161.7\text{mm}$$

$$ID_{\text{casing}} = 224.4\text{mm}$$

$$E = 210000\text{N/mm}^2$$

$$a = 5500\text{mm}$$

$$l = 6000\text{mm}$$

$$v_{\text{max}} = \frac{ID_{\text{casing}} - OD_{\text{tubing}}}{2}$$

$$v_{\text{max}} = \frac{Fa^2}{6EI}(3l - a)$$

$$I = \frac{1}{2} \frac{\pi}{64} (OD_{\text{tubing}}^4 - ID_{\text{tubing}}^4)$$

$$I = \frac{1}{2} \frac{\pi}{64} (177.8^4 - 161.7^4) = 7.749 \cdot 10^6 \text{mm}^4$$

$$F = \frac{6\delta EI}{a^2(3l - a)} = \frac{6 \cdot (23.3\text{mm}) \cdot (2.1 \cdot 10^5 \text{N/mm}^2) \cdot (7.749 \cdot 10^6 \text{mm}^4)}{(5000\text{mm})^2 (3 \cdot (6000\text{mm}) - (5000\text{mm}))} = \underline{\underline{602\text{N}}}$$

Thick cylinder with internal pressure only

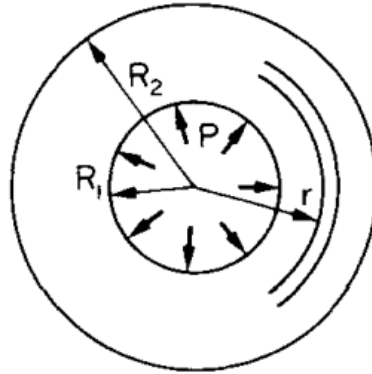

Figure B- 2: Cylinder cross section.

$$R_1 = 80.85 \text{ mm}$$

$$R_2 = 88.9 \text{ mm}$$

$$r = \frac{R_2 + R_1}{2} = 84.9 \text{ mm}$$

$$\nu = 0.3$$

$$E = 210000 \text{ N/mm}^2$$

$$F = 2F_{\text{beam}} = 1204 \text{ N}$$

$$l = 1000 \text{ mm}$$

$$p = \frac{F}{\pi ID_{\text{tubing}} l} = \frac{(1204 \text{ N})}{\pi (161.7 \text{ mm})(1000 \text{ mm})} = 2.37 \cdot 10^{-3} \text{ MPa}$$

$$\sigma_r = -p \frac{\left(\left(\frac{R_2}{r} \right)^2 - 1 \right)}{\left(\left(\frac{R_2}{R_1} \right)^2 - 1 \right)} = -(2.37 \cdot 10^{-3} \text{ MPa}) \frac{\left(\left(\frac{88.9 \text{ mm}}{84.9 \text{ mm}} \right)^2 - 1 \right)}{\left(\left(\frac{88.9 \text{ mm}}{80.85 \text{ mm}} \right)^2 - 1 \right)} = -1.093 \cdot 10^{-3} \text{ MPa}$$

$$\sigma_H = p \frac{\left(\left(\frac{R_2}{r} \right)^2 + 1 \right)}{\left(\left(\frac{R_2}{R_1} \right)^2 - 1 \right)} = (2.37 \cdot 10^{-3} \text{ MPa}) \frac{\left(\left(\frac{88.9 \text{ mm}}{84.9 \text{ mm}} \right)^2 + 1 \right)}{\left(\left(\frac{88.9 \text{ mm}}{80.85 \text{ mm}} \right)^2 - 1 \right)} = 0.0238 \text{ MPa}$$

$$\sigma_L = \frac{pR_1^2}{R_2^2 - R_1^2} = \frac{(2.37 \cdot 10^{-3} \text{ MPa})(80.85 \text{ mm})^2}{(88.9 \text{ mm})^2 - (80.85 \text{ mm})^2} = 0.011 \text{ MPa}$$

$$\Delta D = \frac{2r}{E} [\sigma_H - \nu\sigma_r - \nu\sigma_L] = \frac{2(84.9 \text{ mm})}{(2.1 \cdot 10^5 \text{ N/mm}^2)} [(0.0238) - (0.3 \cdot 1.093 \cdot 10^{-3}) - (0.3 \cdot 0.011)] \text{ MPa} = \underline{\underline{1.63 \cdot 10^{-5} \text{ mm}}}$$

Appendix C: FEA - Plastic Deformation Approach

Table C- 1: Model 1 - One axial cut.

Point reference Name	Face Length mm	Pressure MPa	Stress step 1 MPa	Stress step 2 MPa	Probe	Probe	Probe	Probe	Probe	Probe
					1 Step 1 mm	1 Step 2 mm	2.1 Step 1 mm	2.1 Step 2 mm	2.2 Step 1 mm	2.2 Step 2 mm
1 cut -1	1000	2.0	701,4	415.9	81.2	80.9	78.4	80.9	91.5	81.1
1 cut -2	1000	2.5	759,4	559.7	87.7	81.4	75.3	80.5	98.2	81.9
1 cut -3	2000	1.5	782.0	454.1	87.7	81.2	78.3	80.6	92.4	81.2
1 cut -4	3000	1.5	765.8	591.6	93.2	85.4	76.7	77.5	96.2	85.4
1 cut -5	4000	1.0	739.7	543.5	87.2	81.1	78.6	80.7	90.8	81.0
1 cut -6	5000	1.0	728.1	588.0	88.0	81.5	78.9	80.6	90.9	81.2

Table C- 2: Model 2a - Two axial cuts.

Point reference Name	Face Length mm	Pressure MPa	Stress Step 1 MPa	Stress Step 2 MPa	Probe	Probe	Probe	Probe
					1 Step 1 mm	1 Step 2 mm	2 Step 1 mm	2 Step 2 mm
2 cut a-1	1000	1.0	675.6	537.9	91.9	80.9	83.0	80.9
2 cut a-2	1000	1.5	720.8	589.7	98.1	81.5	84.8	80.9
2 cut a-3	1000	2.0	726.9	572.7	104.2	83.3	87.4	80.9
2 cut a-4	1000	2.5	829.0	661.6	104.2	83.4	89.4	81.3
2 cut a-5	1000	3.0	833.9	667.9	104.2	83.2	93.2	83.7
2 cut a-6	1000	3.5	831.7	669.4	104.2	83.2	95.7	85.4
2 cut a-7	1000	4.0	833.2	669.8	104.2	83.3	97.0	86.5
2 cut a-8	2000	4.0	829.7	702.5	104.2	85.8	97.4	87.3

Table C- 3: Model 2b – Two axial cuts – Smaller pressurized area.

Point reference name	Face length mm	Pressure MPa	Stress step 1 MPa	Stress step 2 MPa	Probe	Probe	Probe	Probe
					1 Step 1 mm	1 Step 2 mm	2 Step 1 mm	2 Step 2 mm
2 cut b-1	1000	6.0	823.5	645.0	100.7	82.1	101.0	91.1
2 cut b-2	1000	7.0	815.0	613.1	102.3	83.3	101.0	90.8
2 cut b-3	2000	5.0	855.7	625.9	104.1	86.6	99.0	89.1
2 cut b-4	2000	6.0	844.4	625.9	104.1	86.6	99.0	89.1
2 cut b-5	3000	4.0	844.7	646.4	104.1	89.6	98.0	89.1
2 cut b-6	3000	5.0	841.7	646.5	104.1	89.7	98.9	89.5
2 cut b-7	3000	6.0	846.0	646.7	104.1	89.6	100.0	90.1
2 cut b-8	4000	3.0	846.0	672.3	104.1	90.0	95.0	86.5
2 cut b-9	4000	4.0	845.0	672.3	104.1	93.0	98.0	89.4
2 cut b-10	4000	5.0	846.3	672.3	104.1	93.0	98.9	90.0

Table C- 4: Model 3 - Four axial cuts.

Point reference Name	Face length mm	Pressure MPa	Stress step 1 MPa	Stress step 2 MPa	Probe 1	Probe 1
					step 1 mm	step 2 mm
4 cut -1	1000	0.3	698.9	209.6	91.5	80.9
4 cut -2	1000	0.4	707.7	287.6	95.2	80.9
4 cut -3	2000	0.5	717.7	418.3	98.8	81.1
4 cut -4	2000	0.8	733.5	364.5	99.4	81.0

Figure C-1 to C-5 illustrates the deformation in load step two (pressure = 0) for the simulations point with highest deformation. Black circular lines represent original shape. Figure C-6 to C-7 represents stress distribution on the simulation with highest total force applied on, 2 cut b-10.

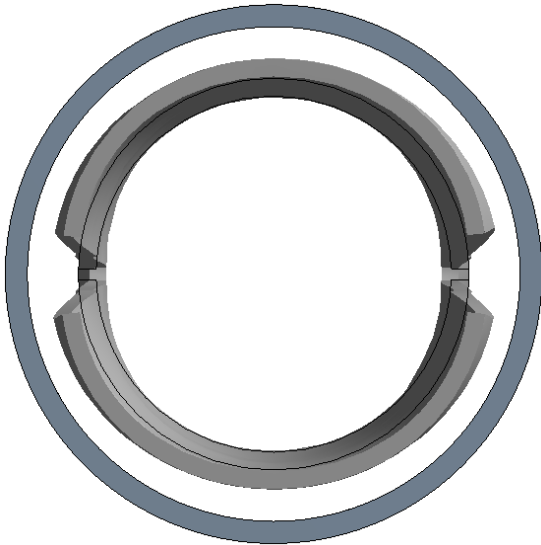

Figure C- 1: Bottom View – 2 cut b-5.

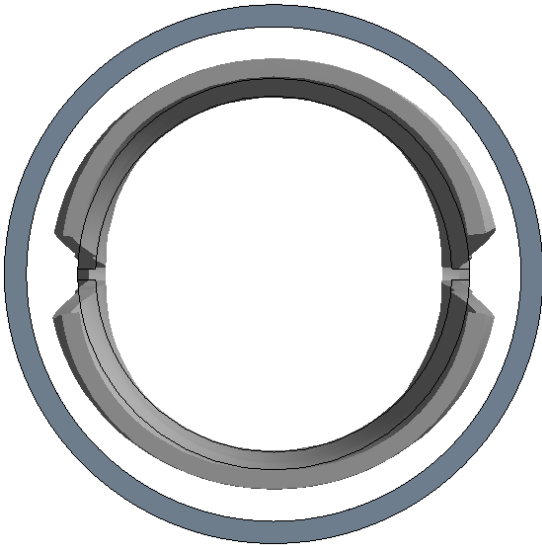

Figure C- 2: Bottom View – 2 cut b-6.

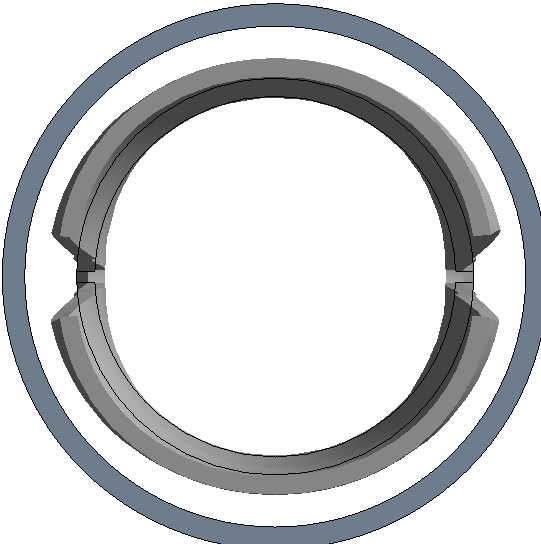

Figure C- 3: Bottom View – 2 cut b-7.

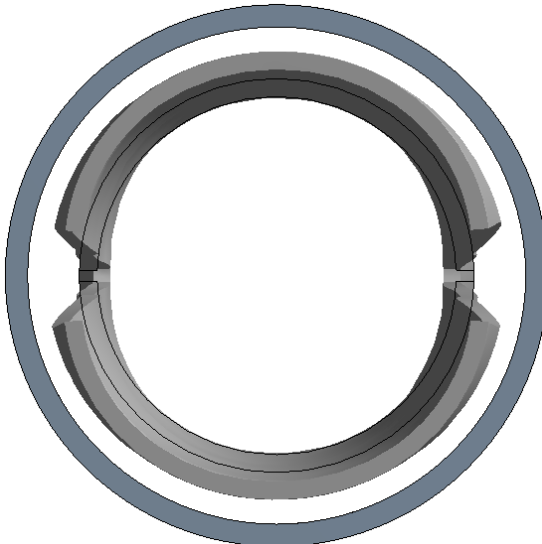

Figure C- 4: Bottom View – 2 cut b-9.

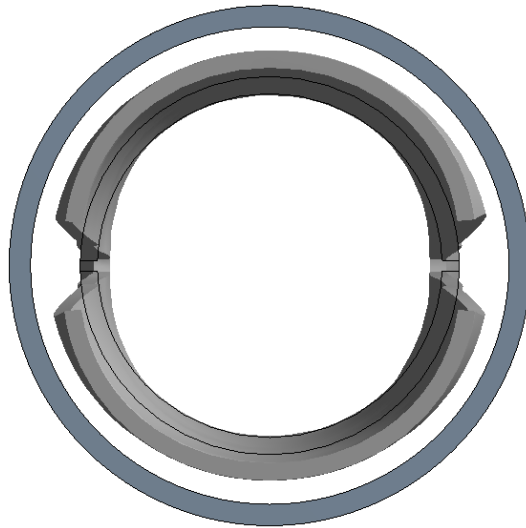

Figure C- 5: Bottom View – 2 cut b-10.

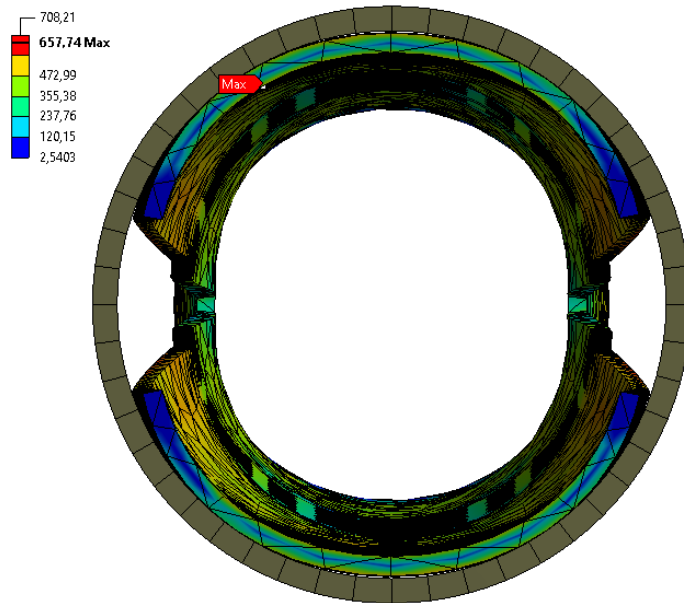

Figure C- 6: Bottom View, Stress distribution load step 1- 2 cut b-10. Max stress, contact between tubing and casing.

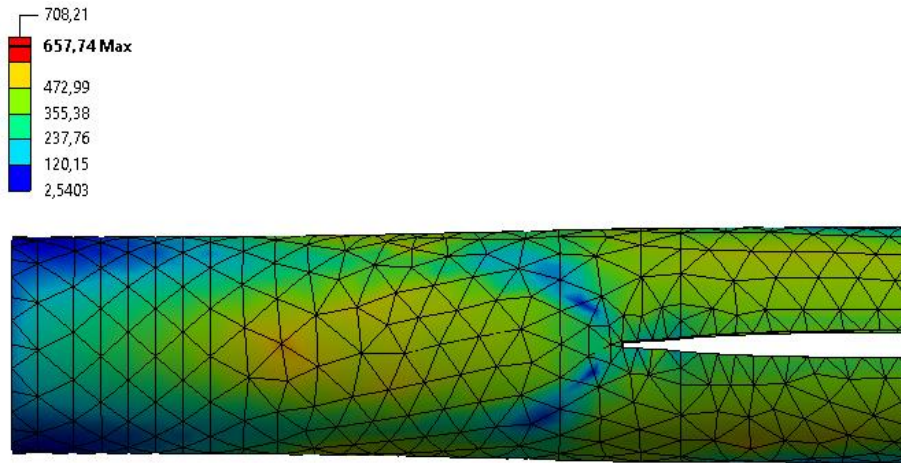

Figure C- 7: Stress distribution around cut end load step 1 - 2 cut b-10.

Appendix D: FEA – Pressure Fitting Approach

Table D- 1: Model 2c - Two Axial cuts – Distance to start of pressurized area 0.5m.

Face length mm	Pressure MPa	Stress step 1 MPa	Probe 1 Step 1 mm	Probe 2 Step 1 mm
1000	2	733.1	88.6	81.6
1000	3	775.9	104.1	87.3
1000	4	783.0	99.5	84.0
1000	5	775.9	104.2	87.3

Table D- 2: Model 2c - Two Axial Cuts – Distance to start of pressurized area 0.2m.

Face length mm	Pressure MPa	Stress step 1 MPa	Probe 1 Step 1 mm	Probe 2 Step 1 mm
1000	2	720.9	88.8	82.6
1000	3	772.4	93.4	84.0
1000	4	769.7	100.1	86.7
1000	5	772.1	104.1	92.1

Table D- 3: Model 2c - Two Axial Cuts - Distance to start of pressurized area 0.1m.

Face length mm	Pressure MPa	Stress step 1 MPa	Probe 1 Step 1 mm	Probe 2 Step 1 mm
1000	2	734.0	88.7	83.4
1000	3	779.5	93.3	85.1
1000	4	781.3	100.3	90.0
1000	5	773.7	104.0	96.9

Table D- 4: Model 2c – Two Axial cuts – Distance to start of pressurized area 0.1m

Face length mm	Pressure MPa	Stress step 1 MPa	Probe 1 Step 1 mm	Probe 2 Step 1 mm
500	4	774.3	89.0	85.1
500	5	770.6	91.5	88.0
500	6	773.5	96.8	100.9
500	8	772.6	98.0	101.3

Appendix E: Parameters for AWSJ

The material presented is based on work carried out in the specialization project [28].

Cutting Parameters

For cutting well tubulars, the output parameter of interest is the depth of the cut. The basic parameters influencing the cutting depth are [60]:

- Water pressure
- Nozzle diameter
- Nozzle traverse rate
- Nozzle standoff distance
- Abrasive mass flow rate

The influence water pressure and nozzle diameter has on the depth of the cut can be seen on Figure E- 1. The graphs indicate increasing the pressure and/or reducing the nozzle diameter while keeping the other process parameter constant increases the depth of the cut.

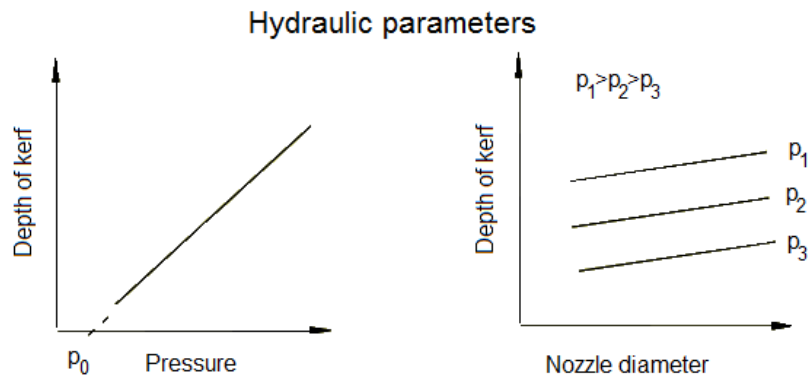

Figure E- 1: Effect of water pressure and nozzle diameter on cut depth [61].

Increasing the abrasive flow rate also increases the depth of the cut, illustrated in Figure E- 2. It is implicit that a critical energy transfer from the jet to the particles is needed to fracture the target work material. By increasing the flow rate more material is removed, which results in a higher cut depth [60].

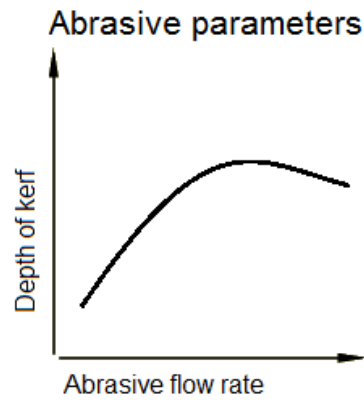

Figure E- 2: Effect of abrasive flow rate on cut depth [61].

Standoff distance is the distance between the nozzle and the target work material during the cutting operation, and traverse rate is the speed of the nozzle per unit time during the cutting operation. Increasing the standoff distance or the traverse rate decreases the depth of the cut, illustrated in Figure E- 3. It has been found that traverse rate has a much bigger impact on cut depth compared to standoff distance.

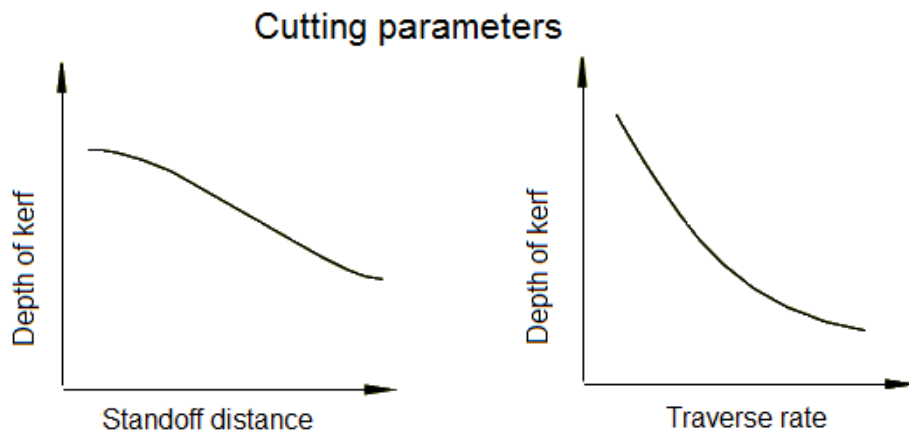

Figure E- 3: Effect of standoff distance and traverse rate on cut depth [61].

Pressure Loss

The pressure loss along a given length is determined from the Darcy-Weisbach equation:

$$\Delta p = f \frac{l}{d} \frac{\rho V^2}{2} \quad (\text{E.1})$$

The friction factor is not constant, but varies based on parameters such as pipe parameters, flow velocity and flow regime. Different empirical correlations and different approaches to

calculate friction factor exist, below is the friction factor correlations proposed by Ove Bratland in Pipe Flow 1 – Single-phase Flow Assurance [62]:

$$Re \leq 2300: \quad f = \frac{64}{Re} \quad (E.2)$$

$$2300 < Re \leq 3100: \quad f = 4.6525(10^{-4})Re^{-1.042275} \quad (E.3)$$

$$3100 < Re \leq 20000: \quad \text{Straight line from } Re=3100 \text{ and } Re=20000 \quad (E.4)$$

(computed as for $Re \geq 20200$)

$$Re \geq 20200: \quad \frac{1}{\sqrt{f}} = -\frac{2}{u_s} \log_{10} \left[\left(\frac{1.547}{Re\sqrt{f}} \right)^{0.9445u_s} + \left(\frac{k_s}{3.7d} \right)^{u_s} \right] \quad (E.5)$$

The Reynolds number, Re can be determined from the equation:

$$Re = \frac{vd}{\nu} \quad (E.6)$$

Pressure loss from change in diameter can by assuming lossless flow be found by Bernoulli's equation:

$$p_1 + \frac{1}{2}\rho v_1^2 + \rho gh_1 = p_2 + \frac{1}{2}\rho v_2^2 + \rho gh_2 \quad (E.7)$$

Appendix F: Cylinder Pressure

Tubing:

Cut kerf = 5mm

$p_{\text{expansion}} = 6\text{MPa}$

Angle from center to edge of pressurized area = 50°

Length pressurized area = 500mm

$ID_{\text{tubing}} = 161.7\text{mm}$

$ID_{\text{cylinder}} = 120\text{mm}$

Cylinder:

$D_{\text{piston}} = 130\text{mm}$

$D_{\text{piston rod}} = 20\text{mm}$

$C_{\text{tubing}} = \pi ID_{\text{tubing}} = 507.74\text{mm}$

$A_{\text{pressurized area}} = \frac{4(\text{Angle from center to edge of pressurized area} - \text{Cut angle})}{360^\circ} (C_{\text{tubing}})(\text{Length pressurized area}) = 136040\text{mm}^2$

$F = PA_{\text{pressurized area}} = 0.82\text{MN}$

$P_{\text{inlet}} = \frac{F}{A_{\text{cylinder}}} = \frac{F}{\frac{\pi (ID_{\text{cylinder}}^2 - D_{\text{piston rod}}^2)}{4}} = 63.0\text{MPa}$

Appendix G: Single trip tool - Hydraulic schematic

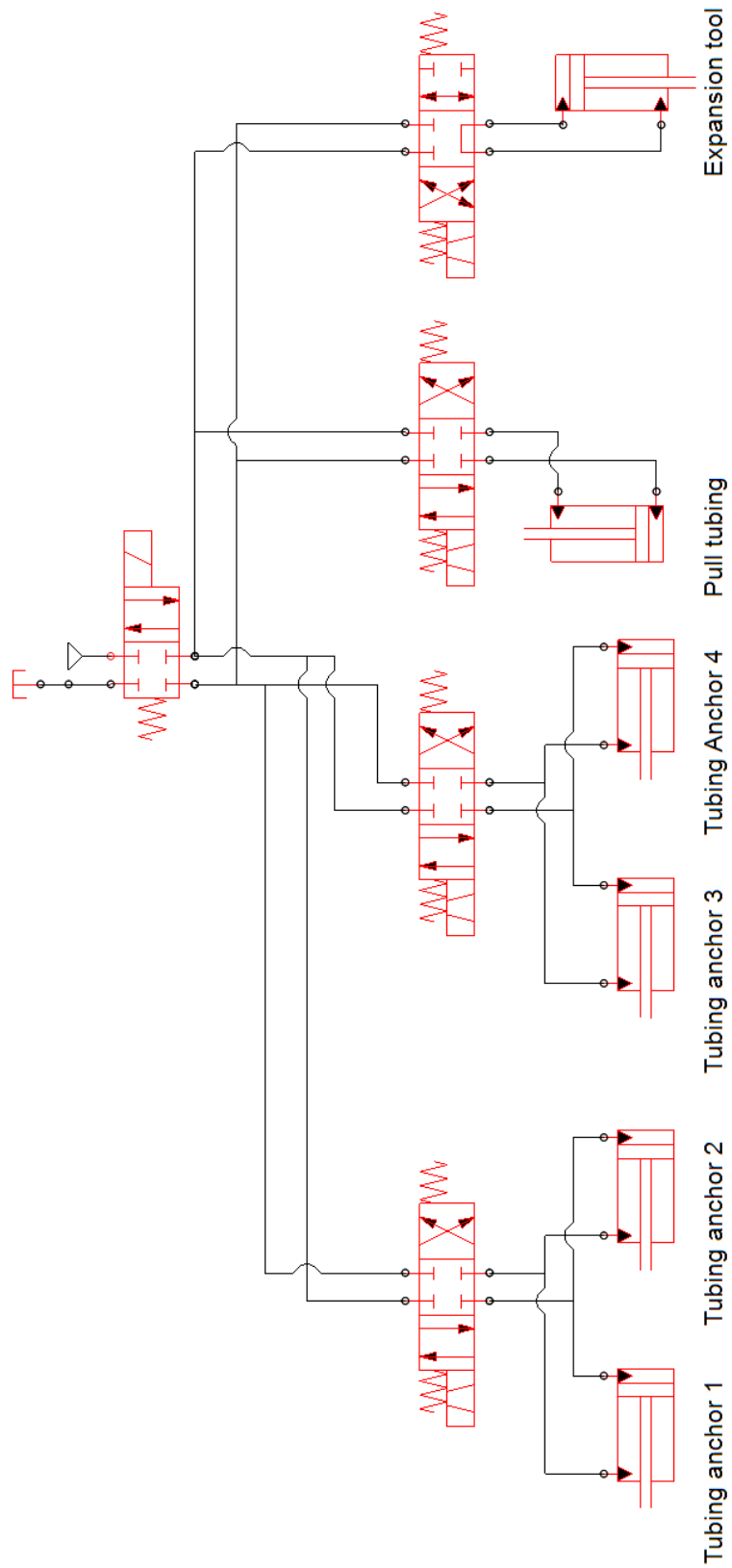

Figure G- 1: Single trip tool hydraulic schematic.