

Suppressing Pressure Oscillations in Offshore Drilling: Control Design and Experimental Results

Anders Albert, Ole Morten Aamo, *Member, IEEE*, John-Morten Godhavn, and Alexey Pavlov, *Member, IEEE*

Abstract

As oil exploration and development costs rise, the oil industry increases its efforts to improve oil recovery (IOR) from existing fields. IOR is achieved mainly by drilling more wells, but drilling in partially depleted reservoirs is challenging due to narrow pressure margins. Offshore drilling in harsh environments, such as the North Sea, presents additional challenges, since the heaving motion from a floating rig induces large surge and swab pressures in the well. The paper suggests a remedy for this problem using automatic control of well pressure. Taking advantage of an experimental lab facility recently completed at NTNU, a model of the drilling system is developed using subspace identification methods. The model serves as a basis for state estimation and controller design using model predictive control. Applying the controller to the lab facility, pressure oscillations are suppressed by 70-90% compared to the open-loop case, depending on the period of the heave motion

Index Terms

Managed pressure drilling, constant bottomhole pressure, disturbance attenuation, model predictive control

I. INTRODUCTION

DURING drilling operations a fluid, called mud, is pumped down through the hollow drillstring. The main purpose of the mud is to transport cuttings up to the surface through the annulus between the hole walls and the drillstring (see Figure 1). In addition, the mud is carefully designed to control

A. Albert and O. M. Aamo are with the Department of Engineering Cybernetics, Norwegian University of Science and Technology, 7491 Trondheim, Norway (e-mail: anders.albert@ntnu.no; aamo@ntnu.no)

J.-M. Godhavn is an Adjunct Professor with the Department of Petroleum Engineering and Applied Geophysics, NTNU, 7491 Trondheim, Norway (e-mail: jmgo@statoil.com)

A. Pavlov is with the Department of Intelligent Well Construction, Statoil Research Center, 3910 Porsgrunn, Norway (e-mail: alepav@statoil.com)

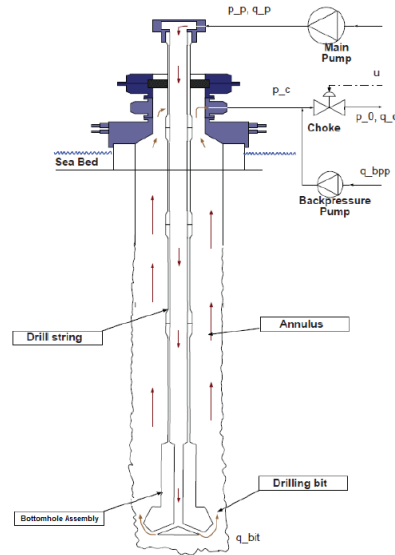

Fig. 1. CBHP setup (courtesy of Dr. Glenn-Ole Kaasa, Statoil)

the pressure profile in the well, which has to be higher than the pore pressure to avoid influx from the reservoir, but sufficiently low to avoid fracturing the well. Violating these constraints may lead to blowout with potentially severe consequences to personnel and the environment, or loss of the well with significant economic damage.

Managed Pressure Drilling (MPD) has become a popular set of techniques for drilling wells with particularly difficult pressure margins [3], [8]. One such MPD technique is called constant bottomhole pressure (CBHP). In this case, the annulus is sealed off and the flow out at the surface is controlled by a choke combined with a back pressure pump (see Figure 1). This facilitates much faster pressure control than that allowed by changing mud weight and main pump flow rate, and sets the stage for automatic control [4], [10], [15]–[18].

Controlling the downhole pressure becomes particularly difficult when drilling from a floating rig, which heaves with the waves. During drilling, a heave compensator acts to keep constant weight on the bit. However, when the drillstring is in slips for a connection (extending the drillstring), it moves with the heaving rig and acts as a piston downhole. This creates surge (moving into the hole) and swab (moving out of the hole) pressure fluctuations that can be in the order of tens of bars [11], [13], while the objective of offshore MPD is to regulate downhole pressure within ± 2.5 bar [2].

The main objective of the CBHP strategy is to keep the pressure in the open section of the well (bottom part) steadily within prescribed pressure margins. Most of the well (top part) is secured by cemented steel

casing and can take practically any pressure. It is not feasible to regulate the pressure to arbitrary set points at more than one point in the well, but if the bottom hole pressure is successfully regulated, the pressure profile throughout the well will be steady under normal drilling conditions. In the presence of heave, the pressure will oscillate in most of the well even if the bottom hole pressure is successfully regulated. This is not a problem, however, since oscillations in the open section of the well will be small.

Several methods have been suggested to deal with the heave problem by incorporating automatic control strategies into CBHP [1], [5]–[7]. In this paper, we exploit a new experimental laboratory that has recently been completed¹ through applying a subspace identification technique to obtain a model for use in a model predictive controller (MPC). and apply a subspace system identification technique to obtain a model for use in a model predictive controller (MPC). The performance of the controller is tested in lab experiments, and shown to significantly suppress pressure fluctuations.

II. EXPERIMENTAL LAB SETUP

A. Design and Governing Assumptions

The purpose of the lab is to model a connection scenario during which the heave problem described above occurs, and to facilitate testing of control strategies for attenuating downhole pressure oscillations. One of the main challenges of the control problem is that the periodic disturbance has a period for which pressure wave dynamics in the well must be considered. To reflect this problem in the lab, the scaling must be such that the ratio between well length and disturbance period is sufficiently large. Well length is limited by the physical lab space available, and disturbance frequency is limited by a number of factors, including bandwidth of actuators, pressure limitations and computer sampling time. These considerations resulted in a minimum disturbance period of $3s$, and a well length of $900m$. To accommodate these requirements within the physical lab space available, it was decided to disregard the effect of the drill string, and only model the moving bottom hole assembly. This simplification allows the majority of the well - 900 meters - to be coiled up, while only the lower part of the well - 80 centimeters - containing the bottom hole assembly is straight. Neglecting the effect of the drill string in the lab is justifiable, since during connections (which is when heave is a problem) the drillstring is not used for pumping mud and there is no weight on bit. Furthermore, the downhole pressure oscillations are mainly a result of the surge and swab pressures caused by the bottom hole assembly moving up and down, which is included in the lab. In practice, the effect of the rest of the drill string can be incorporated into the model, if necessary.

¹The heave-lab has been set up at the Department of Petroleum Engineering & Applied Geophysics at NTNU as a student project. It is funded by Statoil AS.

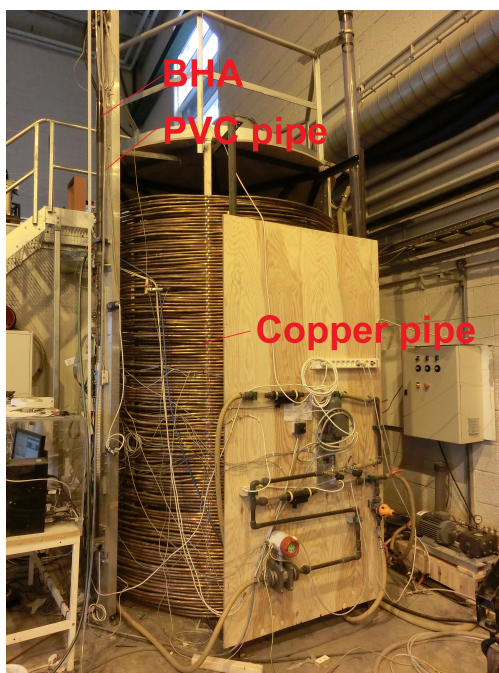

Fig. 2. Photo 1 of Experimental Lab



Fig. 3. Photo 2 of Experimental Lab

The lab is a scaled-down version of a real vertical well. Table I summarizes the lab parameters, and compares them with the real well. The majority of the well is represented by a 900 meter long coiled copper pipe of inner radius 16mm (see Figure 2), while the bottom part of the well is represented by a PVC pipe of inner radius 42.5mm and height 80cm. Inside the PVC pipe, a cylinder representing the

bottom hole assembly is connected to an electrical motor via two rods and a sawtooth belt (see Figure 3). The upper rod represents the drill string, and is dimensioned such that the ratio of the cross sectional areas of the drill string to the well corresponds to that of the real well. The lower rod is there to keep the BHA aligned, and is given a different diameter than the upper rod to achieve fluid displacement into the copper pipe as the bottom hole assembly moves. The PVC pipe representing the bottom part of the well is transparent, allowing visual inspection of the moving bottom hole assembly. The choke is tailor-made for the heave lab, and consists of an electrical motor driving a choke valve. Water is used as drilling mud. Figure 4 shows a schematic of the lab setup.

The BHA diameter governs the pressure drop over the BHA as it moves. It has been selected so that the BHA can be driven at velocities comparable to those experienced in practice, while keeping within pressure margins of the lab (0–10 bar). As mentioned, the length of the well (900m) and the minimum period of the disturbance (3s) have been selected in order to achieve a time of travel for pressure waves through the well that is significant relative to the time period of the disturbance. This delay is what makes the control problem challenging. The amplitude of the BHA movement is selected to give as large pressure oscillations as possible without violating the pressure margins of the lab. This worst case amplitude was found to be 39cm, 25cm and 13cm for 10s, 5s and 3s disturbance period, respectively.

TABLE I
SCALING OF THE LAB

Component	Real well	Lab
Well length (copper pipe)	4000m	900m
Copper pipe diameter	-	16mm
Well diameter (PVC)	8.5in	42.53mm
PVC pipe length	-	80cm
Drillstring (upper rod)	5in	25mm
Lower rod	-	22mm
BHA diameter	6.5in	40.9mm
BHA length	70m	35mm
Disturbance period	11s	3s
Disturbance amplitude	1.5m	40cm

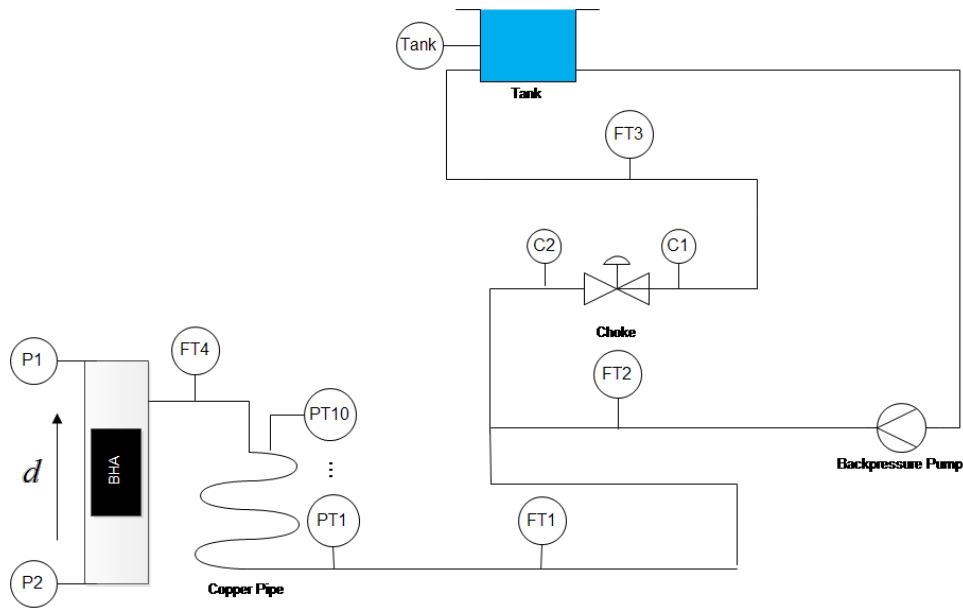

Fig. 4. Schematic of the heave lab

B. Instrumentation

The heave lab has been set up with extensive instrumentation to allow direct monitoring of pressures throughout the well and fluid flow rates at key locations. Pressure transmitters are located below and above the BHA (denoted P2 and P1 in Figure 4), every 100 meters along the copper pipe (PT1–PT10), and before and after the choke (C2 and C1). Fluid flow transmitters are located downstream the choke (FT3), at the outlet of the back pressure pump (FT2), at the top-side of the copper pipe (FT1), and at the outlet of the copper pipe (FT4). The lab provides measurements and accepts control signals for the electrical motors driving the choke valve and the BHA through an interface to a computer running MATLAB and SIMULINK. A SIMULINK diagram has been set up providing measurement monitoring and data logging and facilitating rapid implementation of control strategies.

C. Low-level Control Loops

Two control loops have been implemented in the SIMULINK diagram as utility tools for the user. One controls the BHA movement by tracking a desired trajectory specified by the user. In the present work, a simple harmonic is used. The other loop controls the choke pressure (C2) by tracking a pressure reference signal. While the former is particular to the lab - it's purpose is mimicking heave motion - the latter is required in a real application and is designed as a PI-controller with gain scheduling. While gain scheduling for the proportional gain turned out to have little effect, scheduling on the integral time gave better performance. Qualitatively, the scheduler decreases the integral time with increasing pressure or

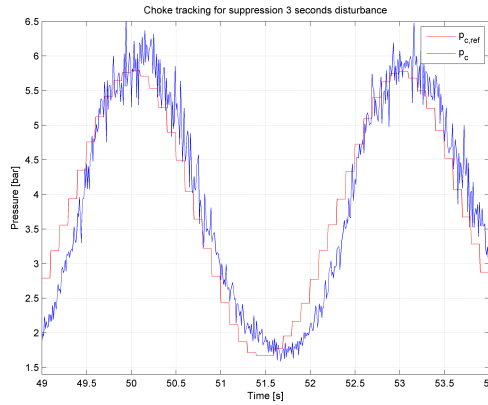

Fig. 5. Performance of the choke pressure controller.

tracking error. Figure 5 demonstrates the performance of the choke controller while tracking the reference signal from the MPC-controller during suppression of a sine disturbance with 3 second period. The controller performs satisfactorily, however with a small time lag.

III. SYSTEM IDENTIFICATION

In the approaches used by [1], [5]–[7], the model equations for the connection scenario simplify to a set of linear equations with the exception of the choke valve. The linear well model assumption, which we will adopt here, comes from the fact that the well flow is laminar during connections since the main pump is stopped. Assuming that the choke pressure controller is perfect, with the exception of a time lag, the lab setup is modeled for the purpose of control design in three parts as shown in Figure 6. While the parameters of the disturbance and lag models are assumed known (the models are stated in Sections III-B and III-C), a black box approach is used for identifying the linear well model.

A. Linear Well Model

As shown in Figure 6, the well model has two inputs and one output. The output is downhole pressure, $p_b(k)$, which is the variable to be regulated. The two inputs are choke pressure, $p_c(k)$, and velocity of the BHA, $d(k)$. Two different subspace identification algorithms were used to identify a discrete linear model in the form

$$x_w(k+1) = A_w x_w(k) + B_w p_c(k) + E_w d(k) + K_w e_w(k) \quad (1a)$$

$$p_b(k) = C_w x_w(k) + D_w p_c(k) + F_w d(k) + e_w(k) \quad (1b)$$

$$\text{cov}(e_w(k)) = R_w \quad (1c)$$

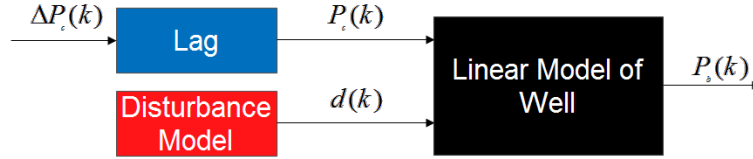

Fig. 6. Models Used in Lab

where $x_w \in \mathbb{R}^n$ is the system state of the well, p_c is the input, p_b is the output, A_w, B_w, C_w, D_w, E_w and F_w are system matrices and K_w is the Kalman gain with R_w being the covariance of the noise, e_w . The subscript w is used to indicate that the variables relate to the well model. The two subspace algorithms used were DSR [14] and the one developed by Overschee and Moor in [12]. Both algorithms take the dynamic order of the system as input.

The BHA velocity and choke pressure were set to follow multiple sine signals of different frequency and amplitude. Multiple such datasets were made, and for each dataset, both the subspace algorithms were run. The resulting models were then tested against a validation set consisting of datasets where the BHA velocity and choke pressure were set to follow sine waves of 3, 5 and 10 seconds periods with different amplitudes and with additional perturbation added. The models were compared by taking the average (positive) distance between the predicted pressure using the models and the measured pressure from the validation set. The Overschee algorithm found a model of order six that proved the most accurate.

The identification algorithm yielded D_w very close to zero. This reflects the fact that the pressure at the choke does not have an instantaneous effect on the bottomhole pressure, due to the delay related to the pressure wave propagating through the 900m long well. The identified model is therefore adjusted by setting $D_w = 0$ in equation (1b). The resulting model used for control design and state estimation is

$$x_w(k+1) = A_w x_w(k) + B_w p_c(k) + E_w d(k) \quad (2a)$$

$$p_b(k) = C_w x_w(k) + F_w d(k) \quad x_w(k) \in \mathbb{R}^6. \quad (2b)$$

A comparison of the estimated bottomhole pressure using the model and the measured bottomhole pressure can be found in Figure 7 over a prediction horizon used by the MPC in Section IV-B.

B. Disturbance Modeling

In order to suppress the disturbance using MPC, a prediction of the disturbance over the MPC horizon is needed. In both [6] and [5] the disturbance is modeled as a finite sum of simple harmonics. We adopt

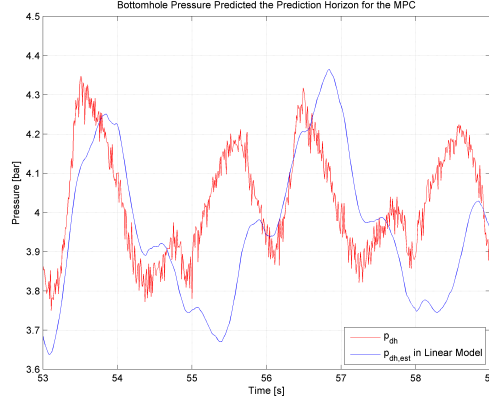

Fig. 7. Estimated bottomhole pressure with identified model over a prediction horizon in MPC-controller from section IV-B

this model here, and restrict it to contain one frequency, representing the dominant frequency of the disturbance. The model thus becomes

$$x_d(k+1) = A_d x_d(k) \quad d(k) = C_d x_d(k) \quad (3)$$

with

$$A_d = \begin{bmatrix} \cos \omega \Delta t & \sin \omega \Delta t \\ -\sin \omega \Delta t & \cos \omega \Delta t \end{bmatrix} \quad C_d = \begin{bmatrix} 1 & 0 \end{bmatrix} \quad (4)$$

where x_d is the disturbance state, d is the disturbance and A_d and C_d are the system matrices. This model assumes a priori knowledge of the frequency of the disturbance, ω . Δt is the sampling time.

C. Time Lag Model

Having assumed that the choke pressure controller performs perfectly with the exception of a constant time lag, D , we allow the MPC to take the time lag into account by incorporating it into the model. By appropriate selection of the time step, we have $D = m\Delta t$ for some integer $m > 0$. A pure time lag can then be modeled as

$$x_l(k+1) = \bar{A}_l x_l(k) + \bar{B}_l p_c^*(k) \quad p_c(k) = \bar{C}_l x_l(k) \quad (5)$$

with

$$\bar{A}_l = \begin{bmatrix} 0 & I \\ 0 & 0 \end{bmatrix}, \quad \bar{B}_l = \begin{bmatrix} 0 & \dots & 0 & 1 \end{bmatrix}^T, \quad \bar{C}_l = \begin{bmatrix} 1 & 0 & \dots & 0 \end{bmatrix} \quad (6)$$

where I is the $(m-1) \times (m-1)$ identity matrix. p_c^* is the desired choke pressure reference to the choke pressure controller of Section II-C. The time lag was found experimentally to be 0.3s. Rather than

penalizing the choke pressure in the MPC, it makes sense to penalize change in desired choke pressure, given by

$$\Delta p_c^*(k) = p_c^*(k) - p_c^*(k-1). \quad (7)$$

Since

$$p_c^*(k-1) = \bar{B}_l^T x_l(k), \quad (8)$$

we have

$$p_c^*(k) = \Delta p_c^*(k) + \bar{B}_l^T x_l(k), \quad (9)$$

which substituted into (5) gives

$$x_l(k+1) = A_l x_l(k) + B_l \Delta p_c^* \quad p_c(k) = C_l x_l(k) \quad (10)$$

with

$$A_l = \bar{A}_l + \bar{B}_l \bar{B}_l^T, \quad B_l = \bar{B}_l, \quad C_l = \bar{C}_l. \quad (11)$$

IV. MPC FOR BOTTOMHOLE PRESSURE REGULATION

A. Composite Model for MPC Design

The model used for MPC is obtained by assembling the models (2a), (3) and (10) from the previous sections into one. Defining

$$x(k) = \begin{bmatrix} x_w(k) \\ x_d(k) \\ x_l(k) \end{bmatrix}, \quad u(k) = \Delta p_c^*(k), \quad y(k) = p_b(k) \quad (12)$$

we get

$$x(k+1) = Ax(k) + Bu(k) \quad y(k) = Cx(k) \quad (13)$$

with

$$A = \begin{bmatrix} A_w & E_w C_d & B_w C_l \\ 0 & A_d & 0 \\ 0 & 0 & A_l \end{bmatrix}, \quad B = \begin{bmatrix} 0 \\ 0 \\ B_l \end{bmatrix}, \quad C = \begin{bmatrix} C_w & F_w C_d & 0 \end{bmatrix}. \quad (14)$$

The objective of the controller is to achieve regulation of $p_b(k)$ to a constant set point p_b^* , that is $y(k) \rightarrow p_b^*$.

B. MPC

There are several advantages to choosing an MPC-controller in the heave suppression problem. It is straight forward to utilize predictions of the disturbance in the optimization horizon, and constraints can easily be handled. The constraints of interest here are limited rate of change in choke pressure and limited choke pressure. They can be expressed, respectively, by

$$\underline{u} \leq u(k) \leq \bar{u} \quad (15)$$

and

$$\underline{p}_c \leq B^T x(k) \leq \bar{p}_c \quad (16)$$

where \underline{u} , \bar{u} , \underline{p}_c and \bar{p}_c are constant bounds. In the interest of keeping the MPC linear, the fact that the choke opening is restricted between fully closed and fully open is not incorporated into the control strategy. However, the choke opening is indirectly constrained though constraining the maximum and minimum choke pressure. This constrain is no guarantee for the choke to stay within its range, but by choosing this constraints carefully the choke can be expected to work comfortably within its range. Given the current state x and input u , the MPC solves the optimization problem

$$\{u^*(k)\}(x, u) = \arg \min_{\{u(k)\}} q_f (y(N) - p_b^*)^2 + \sum_{i=1}^{N-1} [q(y(i) - p_b^*)^2 + ru^2(i)], \quad (17)$$

subject to:

$$x(i+1) = Ax(i) + Bu(i) \text{ for } i = 0, \dots, N-1, \quad (18)$$

$$x(0) = x_0 \quad (19)$$

$$u(0) = u_0 \quad (20)$$

$$u(i) \in [\underline{u}, \bar{u}] \text{ for } i = 1, \dots, N-1 \quad (21)$$

$$Bx(i) \in [\underline{p}_c, \bar{p}_c] \text{ for } i = 0, \dots, N, \quad (22)$$

where q_f , q and r are positive penalty weights. The solution provides a sequence of optimal inputs, $\{u^*(k)\}$, $k = 1, \dots, N-1$, from which $u^*(1)$ is applied to the plant. The optimization problem is solved every time step. The initial condition x_0 was calculated using a filter discussed in the next section.

V. STATE ESTIMATION

The MPC-controller derived in the previous section takes the current state of the system equations (13) as an argument. The system state has three parts. It consists of the system state for the identified system

from equation (2a), which is not measured. Depending on the time lag of the choke pressure tracking controller, D , the state contains a number of previous inputs which are, of course, known. Finally, it contains the state of the disturbance model, which is not measured. The previous inputs need not be given from an outside source, but can be stored internally in the implementation of the MPC-controller and are therefore of no concern for state estimation. The other states, however, must be estimated.

It is natural to divide the filter problem into two parts. One for the well system state and one for the disturbance state. When identifying a system using the subspace-algorithm, the Kalman gain, K_w , is also identified. The well model of equation (2a) is therefore straight forwardly used as the basis for a Kalman filter for the well state, taking choke pressure, BHA velocity and bottom hole pressure as inputs. The resulting filter becomes

$$\hat{x}_w(k+1) = A_w \hat{x}_w(k) + B_w p_c(k) + E_w d(k) + K_w (p_b(k) - \hat{p}_b(k)) \quad (23a)$$

$$\hat{p}_b = C_w \hat{x}_w(k) + F_w d(k) \quad (23b)$$

where $\hat{\cdot}$ indicates estimates of the corresponding variable.

Although the disturbance, $d(k)$, is assumed measured, the disturbance state from the harmonic oscillator of equation (3) is required in order to predict the disturbance over the prediction horizon of the MPC. For this purpose, a Luenberger observer using pole placement to obtain the observer gain K_d , is used. The estimator is thus

$$\hat{x}_d(k+1) = A_d \hat{x}_d(k) + K_d (d(k) - \hat{d}(k)) \quad (24a)$$

$$\hat{d}(k) = C_d \hat{x}_d(k). \quad (24b)$$

VI. RESULTS AND DISCUSSION

The MPC-controller was applied in the lab to suppress pressure oscillations resulting from moving the BHA as sine waves of period 3, 5 and 10 seconds. It was tuned according to the tuning parameters given in Table III. Table II reports the performance of the controller in terms of reduction of peak values for downhole pressure for the three cases. Figures 8, 9 and 10 compare the downhole pressure time series for the controlled and uncontrolled cases, for 3 second, 5 second and 10 second disturbances, respectively.

As can be seen in the figures and Table II, the MPC-controller successfully suppresses disturbances of different time periods by 70 % to 90 %, depending on the period of the disturbance. While the results show significant reduction in pressure oscillations, the experiments also reveal potential for improvement: 1) The assumption of perfect tracking of choke pressure, with the exception of a constant time delay, is violated.

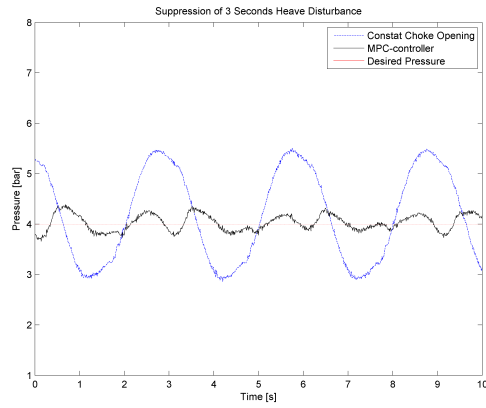

Fig. 8. Suppression of Heave Disturbance with 3 Second Period

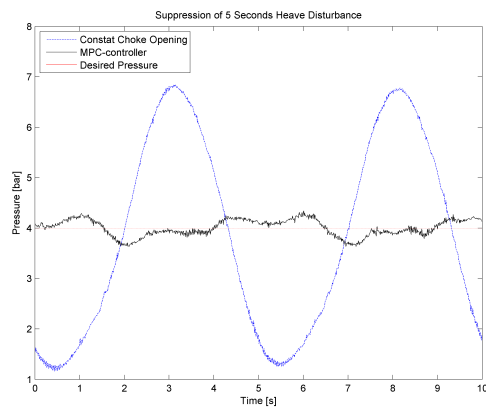

Fig. 9. Suppression of Heave Disturbance with 5 Seconds Period

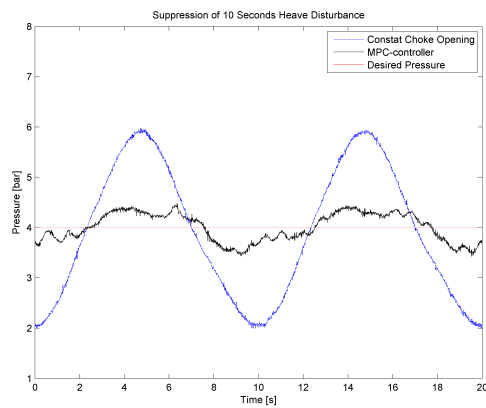

Fig. 10. Suppression of Heave Disturbance with 10 Seconds Period

TABLE II
SUPPRESSION OF SINE WAVE WITH REFERENCE PRESSURE EQUAL TO 4 BAR

Disturbance Period [s]	Without MPC [bar]		With MPC [bar]		Suppression in %
	Low	High	Low	High	
10	2.0	6.0	3.4	4.4	75.0
5	1.2	6.8	3.6	4.3	87.5
3	2.9	5.5	3.7	4.5	69.2

TABLE III
TUNING PARAMETERS USED FOR EACH CASE

Disturbance period	3 sec	5 sec	10 sec
Sample time MPC	0.1	0.2	0.3
Prediction horizon	60	60	60
Limits on ΔP_c	± 1	± 1	± 1
Weight on following reference	1000	1000	1000
Weight on input use	800	2000	800

This can be observed in Figure 5, from which it is clear that the tracking error that the choke controller achieves is not a pure time delay. However, to get a more accurate choke controller the choke valve has to be replaced by a faster, more accurate one. For the scaled down lab, that operates with disturbances that are much faster than those in practice, this is infeasible. The current choke valve and motor are considered to be the best possible for the lab; 2) As can be seen from Figure 7, there is a large potential for improving the predictive capability of the well model. This suggests that the assumption of linear well dynamics is violated, and that a nonlinear model, based on first principles, may improve performance. A nonlinear model would significantly increase complexity of the control strategy and implementation; 3) While Figure 11 shows that the disturbance is predicted perfectly, admittedly, a realistic disturbance will be richer in terms of frequency content as well as time variance. The control strategy should be extended to take into account realistic disturbance models, and; 4) The control strategy relies on measurements of downhole pressure and BHA movement. To obtain these measurements in real time, wired drill pipe must be used. State-of-the-art wired drill pipe technology is still considered unreliable.

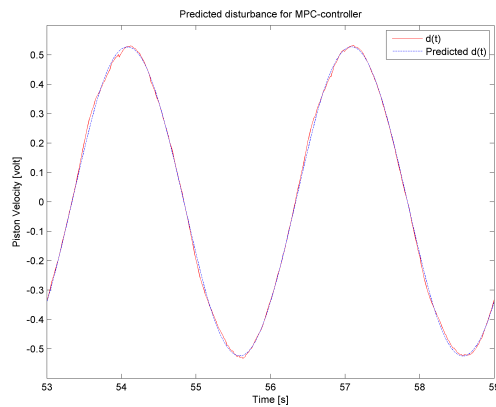

Fig. 11. Prediction of disturbance

VII. CONCLUSION AND FURTHER WORK

In this paper, the heave problem in offshore drilling has been considered and successfully dealt with using automatic control. Utilizing an experimental laboratory setup of a managed pressure drilling system, a control strategy has been developed based on subspace system identification, state estimation by Kalman filtering, and linear model predictive control. The control strategy has been implemented in MATLAB/SIMULINK and applied to the laboratory setup. Experiments demonstrated that, compared to the open-loop case, the MPC-controller suppresses downhole pressure fluctuations by 70-90% depending on the period of the disturbance.

Several areas for further research have been identified. There is potential for performance improvement by improving the model, possibly by taking a first principles approach taking into consideration nonlinear effects. Uncertain parameters will occur though, such as those related to frictional pressure loss and pressure wave propagation. They will need to be identified from experiments. Taking nonlinear effects into account in the model, may require redesign of the other components of the controller by nonlinear state estimation and nonlinear predictive control. The dependence on downhole measurements may be undesirable, and work in the direction of avoiding downhole measurements is reported in [6] and [1]. Finally, more complicated disturbances should be looked at.

REFERENCES

- [1] O. M. Aamo, "Disturbance rejection in 2×2 linear hyperbolic systems," *IEEE Transaction on Automatic Control*, vol. 58, pp. 1095-1106, May, 2013.
- [2] J.-M. Godhavn, "Control requirements for automatic managed pressure drilling system," *SPE Drilling and Completion*, vol 25, pp. 336-345, September, 2010.

- [3] D. Hannegan, "Case studies - offshore managed pressure drilling," *Proceedings of the SPE Annual Technical Conference and Exhibition*, San Antonio, Texas, USA, 2006
- [4] E. Hauge, O. M. Aamo, J.-M. Godhavn and G. Nygaard, "A novel model-based scheme for kick and loss mitigation during drilling," *Journal of Process Control*, vol. 23, pp. 463-472, April, 2013
- [5] I. S. Landet, A. Pavlov and O.M. Aamo, "Modeling and control of heave-induced pressure fluctuations in managed pressure drilling," *IEEE Transactions on Control Systems Technology*, vol. 21, pp. 1340-1351, July, 2013.
- [6] H. Hessam, O.M. Aamo and A. Pavlov, "Attenuation of heave-induced pressure oscillations in offshore drilling systems," *Proceedings of the American Control Conference*, Fairmont Queen Elizabeth, Montreal, Canada, 2012, pp. 4975-4920
- [7] H. Hessam, O.M. Aamo and A. Pavlov, "Suppressing heave-induced pressure fluctuations in MPD," *Proceedings of the IFAC Workshop on Automatic Control in Offshore Oil and Gas*, Trondheim, Norway, 2012
- [8] S. Nas and J. S. Toralde, "Offshore managed pressure drilling experiences in Asia Pacific," *Proceedings of the IADC/SPE Drilling Conference and Exhibition*, New Orleans, Louisiana, USA, 2009
- [9] J. Nocedal and S.J. Wright, *Numerical Optimization*, 2th ed., New York:, Springer, 2006
- [10] G. Nygaard and G. Nævdal, "Nonlinear model predictive control scheme for stabilizing annulus pressure during oil well drilling," *Journal of Process Control*, vol. 16, pp. 719-732, August, 2006
- [11] A. Pavlov, G.-O. Kaasa and L. Imsland, "Experimental disturbance rejection on a full-scale drilling rig," *Proceedings of the IFAC Nonlinear Control Systems Symposium*, Bologna, Italy, 2009
- [12] P. V. Overschee and B.D. Moor, *Suspace Identification for Linear Systems: Theory - Implementation - Applications*, 1th ed., London, England, Springer, 2011
- [13] O. S. Rasmussen and S. Sangesland, "Evaluation of MPD methods for compensation of surge-and-swab pressures in floating drilling operations," *Proceedings of the IADC/SPE Managed Pressure Drilling and Underbalanced Operations Conference and Exhibition*, Galveston, Texas, USA, 2007
- [14] D. D. Ruscio, *Subspace System Identification Theory and Applications*, 1th ed., Porsgrunn, Norway, Telemark Institute of Technology, 1995
- [15] Ø. N. Starnes, O.M. Aamo, and G.-O. Kaasa, "Adaptive redesign of nonlinear observers," *IEEE Transactions on Automatic Control*, vol. 56, pp. 1152-1157, May, 2011.
- [16] Ø. N. Starnes, O.M. Aamo, and G.-O. Kaasa, "Redesign of adaptive observers for improved parameter identification in nonlinear systems," *Automatica*, vol. 47, pp. 403-410, February, 2011
- [17] Ø. N. Starnes, G.-O. Kaasa, and O.M. Aamo, "Adaptive estimation of downhole pressure for managed pressure drilling," *Proceedings of the 2011 IEEE Multi-Conference on Systems and Control*, Denver, USA, 2011
- [18] J. Zhou, Ø. N. Starnes, O.M. Aamo et al. "Switched control for pressure regulation and kick attenuation in managed pressure drilling system," *IEEE Transactions on Control System Technology*, vol. 19, pp. 337-350, March, 2011