

ISBN 978-82-471-4289-9 (printed ver.)
ISBN 978-82-471-4290-5 (electronic ver.)
ISSN 1503-8181



Doctoral theses at NTNU, 2013:96

Lars Løge

Arctic Communications System Utilizing Satellites in Highly Elliptical Orbits

 **NTNU – Trondheim**
Norwegian University of
Science and Technology

 NTNU

Doctoral theses at NTNU, 2013:96

NTNU
Norwegian University of
Science and Technology
Thesis for the degree of
Philosophiae Doctor
Faculty of Information Technology,
Mathematics and Electrical Engineering
Department of Electronics
and Telecommunications

 **NTNU – Trondheim**
Norwegian University of
Science and Technology

Lars Løge

Arctic Communications System Utilizing Satellites in Highly Elliptical Orbits

Thesis for the degree of Philosophiae Doctor

Trondheim, March 2013

Norwegian University of Science and Technology
Faculty of Information Technology, Mathematics
and Electrical Engineering
Department of Electronics and Telecommunications



NTNU – Trondheim
Norwegian University of
Science and Technology

NTNU

Norwegian University of Science and Technology

Thesis for the degree of Philosophiae Doctor

Faculty of Information Technology, Mathematics and Electrical Engineering
Department of Electronics and Telecommunications

© Lars Løge

ISBN 978-82-471-4289-9 (printed ver.)
ISBN 978-82-471-4290-5 (electronic ver.)
ISSN 1503-8181

Doctoral theses at NTNU, 2013:96

Printed by NTNU-trykk

Abstract

Activities in the Arctic and high latitude regions are increasing, and this trend will likely continue in the future. A higher activity level will generate an increasing demand for communications services. Several studies have concluded that there are already unsatisfied demands for communications services in the Arctic. Adequate system solutions must be developed to meet current and future communications requirements. This thesis addresses this issue and proposes a satellite system that can provide reliable communications services with high availability to the Arctic. The Arctic service requirements are discussed and quantified, and a gap analysis identifies the coverage requirements. Satellite orbits, which can provide the required coverage, are subsequently considered with a focus on HEO alternatives. Four promising options are identified with orbital periods of close to 12 h, 16 h, 18 h and 24 h. The effect of a non-critical inclination has been investigated, and an inclination higher than 63.4° is a realistic option only with a 24 h orbit. Fifteen constellation alternatives were defined following consideration of eccentricity effects. They were then evaluated on eight key performance properties where the 12 h and 16 h alternatives were found to be superior. A 12 h alternative was best rated, but the radiation environment and stationkeeping performance are better with 16 h orbits compared to 12 h orbits. However, it is assumed possible to mitigate these effects, and a constellation with three satellites in 12 h orbits was selected as a base case. Frequency alternatives are discussed, and propagation effects are considered for the K_u and K_a bands. System architecture and payload design are also considered along with crucial issues such as coding and modulation, Doppler shift and satellite handover. Link budgets are analyzed based on the resulting system parameters, and design and performance of possible earth stations are presented. The proposed HEO based solution can provide services to the Arctic with a performance level similar to what GEO systems provide elsewhere. The thesis also considers satellite dimensioning and offer rough order of magnitude cost estimates for the proposed space segment.

Acknowledgements

The road towards this finished thesis has been long, but I have been lucky to receive support and encouragement along the way, both from family, friends and colleagues. First, I would like to thank Professor Odd Gutteberg for guiding and helping me with my research, and Department of Electronics and Telecommunications (IET) at NTNU for giving me the opportunity to study towards a PhD. I also deeply appreciate the backing I have received from everybody at the Norwegian Space Centre (NSC) after I started working there in 2009. The support and help I have received from Odd Gangås, Rune Sandbakken and Terje Pettersen have been crucial for me to finalize this thesis. Jostein Rønneberg and Bo Andersen probably also deserve to be thanked for the pressure they have put on me, thinly veiled as encouragement, to finish this work. Friends, both near and far, deserves to be mentioned for not asking too often when I will get my degree, thank you all. I would also like to thank my mom and dad as well as my brother Tore and his wife Emma for supporting and encouraging my endeavors and helping me stay positive. Special thanks to my dad for taking time out of his "busy" schedule to read through the 284 pages and trying to correct my spelling and grammar errors. However, most of all I would like to thank Merethe for hanging in there. I can only imagine how difficult it has been to live with me through this egocentric process. Lastly, everybody that feel they deserve to be mentioned, but are not; I am grateful for your contribution.

Lars Løge

Oslo, 11.03.2013

Contents

1	Introduction	1
1.1	Problem outline	1
1.2	Research context	2
1.3	Thesis structure	2
2	Arctic service and coverage requirements	5
2.1	Arctic service requirements	5
2.1.1	Land based users	6
2.1.2	Maritime users	7
2.1.3	Aeronautical users	8
2.2	Existing service coverage	9
2.3	Required coverage	10
2.4	Service definitions	12
2.4.1	Broadcasting	12
2.4.2	Broadband	13
2.4.3	Backhaul	14
2.4.4	Distress and safety	16
3	Orbit considerations	17
3.1	High Elliptical Orbit	17
3.1.1	12 hour orbit	20
3.1.2	16 hour orbit	20
3.1.3	18 hour orbit	21
3.1.4	24 hour orbit	21
3.2	Orbit conclusions	22
4	Design of constellation alternatives	25
4.1	Orbital inclination	25
4.1.1	Perigee drift	26

4.1.2	Compensating for perigee drift	30
4.1.3	Effect on satellite maneuver lifetime	33
4.2	Eccentricity and satellite handover	37
4.2.1	12 hour orbit	38
4.2.2	16 hour orbit	40
4.2.3	18 hour orbit	42
4.2.4	24 hour orbit	44
4.3	Constellation alternatives	48
5	Constellation assessment and selection	51
5.1	Evaluation of alternatives	51
5.1.1	Free space loss and signal delay	53
5.1.2	Radiation exposure	53
5.1.3	Launch cost factor	55
5.1.4	Coverage	58
5.1.5	Elevation angle	61
5.1.6	Azimuth angle	65
5.1.7	Frequency coordination	69
5.1.8	Stationkeeping	72
5.1.9	Initial operational phase	76
5.2	Constellation discussion	78
6	Considerations on frequency bands	85
6.1	Frequency alternatives	85
6.2	Free space loss	86
6.3	Propagation effects	87
6.3.1	Atmospheric absorption	88
6.3.2	Rain attenuation	88
6.3.3	Clouds, fog, snow and XPD	93
6.3.4	Other effects	95
6.4	Discussion on frequency	95
7	System architecture and payload design	97
7.1	Network topology and payload configuration	97
7.2	Satellite antenna technology	101
7.3	Feeder link antenna	103
7.4	User link antenna	104
7.4.1	Single wide beam antenna solution	106
7.4.2	Quadruple spot beam antenna solution	108
7.4.3	Seven spot beam antenna solution	110

7.5	Coverage area variation	113
7.6	Satellite antenna configuration	118
7.7	Satellite transmitting power	120
7.8	Miscellaneous losses	122
7.9	System noise temperature	124
7.10	Coding and modulation	127
7.11	Doppler shift	131
7.12	Handover between satellites	135
8	Earth station design and performance	139
8.1	Gateway station parameters	140
8.2	Forward link	141
8.3	Return link	149
8.4	Discussion of earth station parameters	164
8.4.1	Broadband services	164
8.4.2	Backhaul services	169
8.4.3	Broadcasting services	170
8.4.4	Distress and safety services	171
8.5	Interference considerations	172
8.6	Selecting frequency band	174
9	Satellite dimensioning and cost	177
9.1	Capacity considerations	177
9.2	Payload power consumption	180
9.3	Satellite platform power requirements	182
9.4	Satellite mass	185
9.5	Launcher options	189
9.6	Space segment cost estimate	192
10	Conclusions and system summary	197
10.1	Arctic communications requirements	197
10.2	Alternative satellite orbits	198
10.3	Effects of high inclination	198
10.4	Orbital eccentricity	199
10.5	Constellation configuration and evaluation	199
10.6	Communications coverage and network topology	200
10.7	Service performance	201
10.8	Cost estimates	202
10.9	Overall system parameters	202

Acronyms	205
References	212
Appendix A Published papers	213
Appendix B Arctic activities	241
B.1 Maritime activities	241
B.1.1 Fishing industry	242
B.1.2 Transport	242
B.1.3 Offshore petroleum industry	245
B.1.4 Research activities	247
B.1.5 Governmental activities	248
B.2 Aeronautical activities	249
B.2.1 Scheduled flights	249
B.2.2 Non-scheduled flights	250
B.2.3 General aviation	250
B.2.4 Communications requirements	250
B.3 Land based activities	251
B.3.1 Local population	251
B.3.2 Research stations	254
B.3.3 Natural resources	255
B.4 Future development	256
Appendix C Available solutions today and near future	257
C.1 Terrestrial systems	257
C.2 GEO satellite systems	258
C.3 Inclined geosynchronous satellites	259
C.4 LEO satellite systems	260
C.4.1 Orbcomm	261
C.4.2 Globalstar	262
C.4.3 Iridium	262
C.5 HEO satellite systems	263
C.5.1 Planned systems	264
C.6 Summary and conclusions	267
Appendix D Frequency regulatory issues	269

Chapter 1

Introduction

This chapter presents a brief introduction to the thesis and the research work performed. First, the objective of the study is given. Secondly, the context of the research and the conditions under which the work have been performed are described. The chapter concludes by giving an overview of the thesis structure.

1.1 Problem outline

Activities in the Arctic and high latitude regions are increasing, and this trend will likely continue in the future. A higher activity level will generate an increasing demand for communications services and applications. Several studies have concluded that there are already unsatisfied demands for communications services in the Arctic. Adequate system solutions must be developed to meet current and future communications requirements. The aim of this study is to address this issue and propose a communications solution that can ensure continued safe and sustainable development in the Arctic and high latitude regions.

The study should:

- Assess Arctic coverage requirements for relevant communications services
- Investigate various highly elliptical satellite orbits

- Discuss constellation alternatives able to support the communications requirements
- Discuss the system design, architecture and performance of a system able to support the communications requirements
- Consider system parameters such as satellite mass and power
- Provide a rough order of magnitude cost estimate

The system solution should be compatible with relevant satellite communications systems operating from Geostationary Earth Orbit (GEO). This constrains the system design in terms of earth station antenna size, and in practice limits the carrier frequency alternatives to the K_u and K_a bands. Voice and narrowband services can be provided to the Arctic by systems such as Iridium. Therefore, the proposed solution should focus on broadband, backhaul and broadcasting services as well as distress and safety services.

1.2 Research context

The research work has been supervised by Professor Odd Gutteberg at the Department of Electronics and Telecommunications (IET), which is part of the Norwegian University of Science and Technology (NTNU) in Trondheim, Norway. IET has financed the research work as part of the Integrated PhD program. The study began in the fall of 2008 after completion of a Master degree focusing on a similar topic. In September 2009, the PhD work was put on hold for a year in favor of trainee position at Norwegian Space Centre (NSC) in Oslo, Norway. The research and PhD work resumed again in September 2010 on a part time basis while also working at NSC with duties closely related to this research topic.

1.3 Thesis structure

In Chapter 2, the communications requirements of the various user types present in the Arctic are considered. The demand for different services and applications in the Arctic is discussed. Assumptions regarding bandwidth requirements for various services are presented. These capacity and coverage requirements form the basis for the service definitions and the system design.

Potential orbit alternatives able to provide the necessary coverage are investigated in Chapter 3. Design of a range of possible constellation alternatives using two or three Highly Elliptical Orbit (HEO) satellites in the relevant 12 h, 16 h, 18 h and 24 h orbits is then studied in Chapter 4. All the constellation alternatives have strengths and weaknesses. Chapter 5 assess and evaluates those, as well as considers the most important trade-offs. A constellation using three satellites in 12 h orbits is selected as a base case because of its superior technical performance and to limit the scope of system considerations. However, a highly interesting alternative is to use a constellation with two satellites in 16 h orbits as it potentially allows for lower system cost and longer satellite lifetime.

The carrier frequency alternatives are considered in Chapter 6. Propagation properties of the K_u and K_a bands are discussed along with regulatory limitations imposed by GEO compatibility. Chapter 7 summarizes the system architecture and payload design. Important considerations are network topology, satellite antenna configuration and payload performance. This chapter also addresses coding and modulation, Doppler shift and satellite handover. In Chapter 8 design of earth stations and their potential performance are studied. Earth station parameters are defined for a set of communications services. The system considerations are taken into account in Chapter 9 to estimate dimensions and costs of a satellite system providing communications services to the Arctic. Chapter 10 presents key findings, conclusions and summarizes the overall system parameters.

Appendix A contains three papers presented at three different conferences as part of the research and PhD study. A summary of the activities in the Arctic is given in Appendix B, and in Appendix C current communications solutions and their capabilities are discussed. Appendix D considers frequency regulatory issues. The research this thesis is based on has used the computer simulation program Satellite Tool Kit (STK) to analyze orbit and constellation alternatives. STK has been crucial in understanding how various orbital parameters influence important aspects such as coverage, elevation angle and satellite handover. The program has also been used to create several of the illustrations provided in this thesis.

Chapter 2

Arctic service and coverage requirements

User requirements should always be the driving force in a satellite system design process. It is only by meeting the needs of users and costumers that a satellite communications system can be successful. Thus, a complete overview and an understanding of the user requirements in terms of services and coverage are essential when designing a satellite communications system.

In this chapter, Arctic service requirements are discussed and quantified. A simple gap analysis is then used to identify the coverage requirements for communications services in the Arctic. At the end of the chapter the services to be provided by the satellite system are defined, both in terms of service type and performance.

2.1 Arctic service requirements

Future Arctic communications demand are uncertain, both in volume and time. The volumes are dependent on the user types and their numbers. It is difficult to assess how attractive the Arctic is to different potential users. The time variable stems from uncertainties related to when user populations in the Arctic will grow. The influx of communications users in the Arctic depends on the development of the climate, and political willingness to open up areas for various activities.

There are limited data available for estimation of Arctic service requirements

Table 2.1: Arctic capacity requirements for the various services shown by segment and total.

Service	Land	Maritime	Aero	Total	Unit
Backhaul	100 - 200	-	-	100 - 200	Mbit/s
Broadband	50 - 100	150 - 250	100 - 150	300 - 500	Mbit/s
Broadcast	20 - 30	20 - 30	20 - 30	20 - 30	channels

with only a few market studies performed [1–5]. Therefore, it has been necessary to make rough estimates of service requirements based on assumptions. Three user segments, land, maritime and aeronautical have been treated independently. In table 2.1, the assumed Arctic communications capacity requirements are summarized. A discussion of each user segment and their service requirements is given in the following sections.

2.1.1 Land based users

Arctic land based users are the local population, research stations and the natural resources industry. The exact service requirements and volumes vary between the user groups, but also within a user group. However, there are large similarities as land based activities tends to be more stationary than maritime and aeronautical activity. Communities in the Arctic are generally very remote. A harsh climate together with large distances result in high investment and maintenance cost for infrastructure between settlements and communities. Thus, terrestrial infrastructure outside of communities is limited. This makes Internet Protocol (IP) trunking and backhaul over satellite the most cost efficient solution. Such a service will be able to provide telephony and broadband access to communities. A local terrestrial network can consequently be used to distribute communications services across a community and its surrounding area.

Backhaul volumes are expected to grow in the future. In 2020, an average backhaul link is expected to have a bandwidth of 3.3 Mbit/s [3]. Large communities will need a higher capacity. Oil and gas installations require substantially higher bit rates in order to support Integrated Operations (IO). With the current number of Arctic communities, a total backhaul capacity requirement in the order of 100 Mbit/s to 200 Mbit/s can be assumed. With more Arctic activity and increased use of data applications this requirement will rise in the future.

Land based broadband services in the Arctic are mostly for small communities not large enough to warrant a backhaul solution. Users with specific requirements in terms of services, applications and bandwidth availability might also set up their own broadband solution. This can be in addition to a community shared backhaul and IP trunking service. For small volumes of backhaul traffic, the distinction between a backhaul service and a broadband service is not evident. A typical broadband service user requirement is for the near term future expected to be in the range of 512 kbit/s to 3 Mbit/s [3]. The number of users is difficult to estimate. However, the total broadband capacity requirements will be less than the backhaul requirements, but can be assumed to be in the same order of magnitude. An aggregated land based Arctic broadband capacity requirement of 50 Mbit/s to 100 Mbit/s is assumed.

Broadcasting services to Arctic communities are important for welfare and information purposes. Access to the same television channels and news updates available further south will help integrate Arctic communities with the rest of the world. Therefore, such amenities can ease the depopulation of Arctic communities and increase the general willingness to live and work in the high North. A broadcasting service should offer as a minimum the same type of service as a basic channel package available from cable, satellite or terrestrial systems in the rest of the world. Thus, a service offering between 20 to 30 channels is the assumed broadcasting requirement for land based Arctic users.

In the proximity of communities distress and safety services are an integral part of the terrestrial infrastructure. Cellular networks can be used for distress calls and local radio and TV stations can distribute safety information. Outside of Arctic communities a satellite based solution is necessary. A logical approach should be to define the service requirements of the broadband and broadcast services to include the necessary distress and safety services.

2.1.2 Maritime users

A commonality between maritime users is that they typically are mobile. In addition to being mobile, they are also affected by wind, weather and waves. This poses a range of challenges that a fixed land based user never will encounter. For communication purposes, the maritime sector can be divided into three. First, there are small vessels which will experience substantial rolling motion already in small waves and fair weather. These vessels will need low gain terminal antennas to communicate. Secondly, there are large and stable vessels and installations that can take advantage of maritime VSAT solutions.

The third group consists of fixed and quasi-fixed offshore installations such as oil platforms and drilling rigs. Users in this group have more in common with land based users than other maritime users.

Access to broadband services is becoming a requirement for all larger vessels which are at sea for extended periods of time. Maritime broadband connections are used for vessel operations, reporting to authorities, internet and email access for crew and a range of other applications. On large vessels with many users of communications applications, such as cruise ships, a maritime broadband service may be used almost as a backhaul service. Maritime broadband data rate requirements are expected to reach 2.5 Mbit/s towards 2020 [3]. The number of Arctic maritime broadband users in the future is uncertain, but an initial total maritime broadband capacity in the range of 150 Mbit/s to 250 Mbit/s is assumed to be required.

Broadcasting services have over the last decade become a requirement for crew welfare in large ocean going vessels. It is assumed that the broadcasting requirements in the maritime sector are comparable to land based requirements. Thus, the same service offering 20 to 30 channels to land based users can be used by the maritime sector.

Distress and safety services are extremely important for the maritime sector. It is beneficial if distress and safety solutions are integrated into other regular services. This will eliminate the need to install extra equipment only for distress and safety. Regular use of a terminal will also make the mariner familiar with the equipment and reduce erroneous use in distress situations. Services with integrated distress and safety solutions will have to be designed for higher reliability and availability than regular services. It will also be required to implement a preemption solution for distress and safety applications, ensuring they get the necessary priority in the system.

2.1.3 Aeronautical users

Aeronautical communications can be generalized into two segments. These segments are cockpit and cabin communications. Communications necessary for flight operations and safety are cockpit communications. Passenger communications and similar services are typical cabin communications. Cockpit communications can also be labeled as Air Traffic Management (ATM) communications. The future European ATM services are under development in the Single European Sky ATM Research (SESAR) project. SESAR oversees a range of development programs such as the IRIS program, which is a

European Space Agency (ESA) Advanced Research in Telecommunications Systems (ARTES) program. Next Generation Air Transportation System (NextGen) is a similar project aimed at modernizing the air transport system in the United States of America (USA). There will be interoperability between the two future ATM systems. Arctic ATM services will have to be compatible with these developments. However, as the future ATM systems still are under development, there are uncertainties tied to their function and requirements. Thus, Arctic ATM services and cockpit communications have not been considered in this study.

Cabin communications are typically information exchange not related to flight operations. Examples are in-flight entertainment applications, passenger communications and similar services. Onboard cellular phone coverage and wireless internet access are becoming popular, and are important for some airlines who wish to distinguish themselves from others. Multiple simultaneous mobile phone calls can be administered on a narrowband data service, but a broadband connection is preferred. An onboard wireless internet service requires access to a broadband service. Broadband access also enhances the selection and quality of in-flight entertainment applications which may be offered passengers. Solutions providing in-flight wireless internet access through satellites in GEO are available today. According to marketing material, transmission speeds of several Mbit/s are available for shared access between passengers and other services. An Arctic aeronautical broadband requirement in the range of 100 Mbit/s to 150 Mbit/s is assumed.

Access to a broadcasting service is also of interest for in-flight entertainment applications. Cross polar routes are used by airlines from many different countries. Therefore, a broadcasting service will have to be diverse to satisfy all users. It is assumed that a channel package of 20 to 30 channels carefully put together can satisfy the most essential aeronautical broadcasting needs.

2.2 Existing service coverage

Broadcast service coverage is mainly given by GEO coverage. Areas with low user density that are not prioritized by satellite broadcasting operators, may require larger user terminal antennas than normal, but stable broadcasting services should be available from one or more GEO satellites up to around 72° to 75° North. Broadband services, defined here to be a solution providing bit rates in excess of 128 kbit/s , also follow GEO coverage. VSAT systems

have a similar coverage as broadcast services. Fixed users with large and specialized antenna systems can up to around 80° north utilize GEO satellites for broadband coverage. Smaller fixed VSAT user terminals as well as mobile and maritime VSAT systems have no coverage above 72° to 75° North. Inmarsat's global L-band coverage is available up to 76° North. They can currently provide bit rates up to 432 kbit/s through the FleetBroadband service.

GEO coverage is also the limitation for backhaul and IP trunking services. The satellite connection used to link Eureka in the Canadian Arctic Archipelago show that backhaul services can be provided up to about 80° North. However, it requires a complex and expensive system of multiple large antennas and advanced signal combining. Such a solution is only cost efficient for large amounts of data generated at critical and important sites. For smaller sites and stations, backhaul coverage is similar to that of VSAT broadband services.

Inmarsat is at present the only provider of satellite based Global Maritime Distress and Safety System (GMDSS) approved distress and safety services in the world. As mentioned above, they provide coverage up to 76° North. Iridium has indicated interest in providing GMDSS through its satellite constellation. However, the Iridium constellation does not meet the current GMDSS requirements. That makes Iridium an unlikely candidate for GMDSS support also in the future.

2.3 Required coverage

Based on the discussion on existing service coverage in the previous section the Arctic service coverage gaps can be derived. It is these gaps a new satellite system for Arctic communications must fill. Thus, the coverage gaps equal the Arctic satellite system's service coverage requirements. Broadcasting, broadband and backhaul services are currently not adequately provided for in the Arctic. These services are not available above 80° North, and they are unstable, unreliable and have limited performance already from 72° to 75° North. Therefore, the required coverage for broadcasting, broadband and backhaul services are the area above 72° North.

Additionally broadcasting and broadband services from a new Arctic satellite system should overlap to some degree with geostationary coverage. Such an overlap would ensure that relevant geographical and political regions are not split between satellite systems. The extent of this overlap is a trade-off which depends on a range of interests. Operators of GEO satellites would want

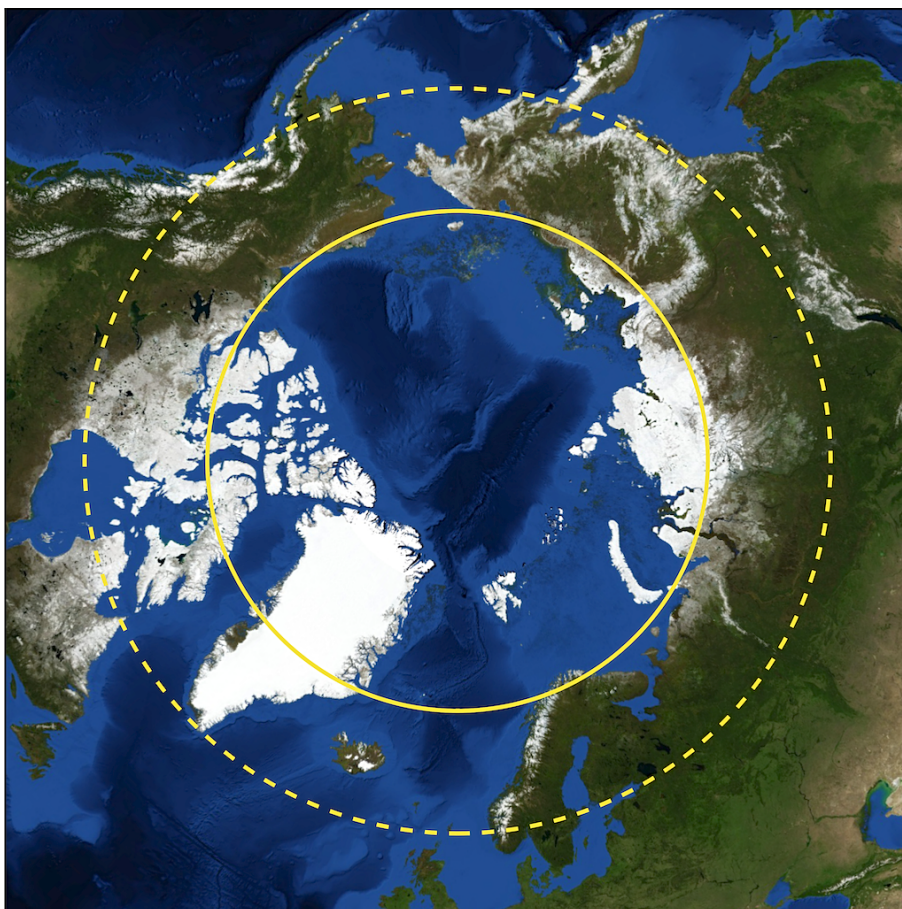

Figure 2.1: Required coverage area for the Arctic satellite communications system considered in this study. The solid yellow circle indicate 70° northern latitude, and define the required coverage area for broadcast, broadband, backhaul and distress and safety services. The dotted yellow circle indicate 60° northern latitude and the extended coverage area.

to minimize such an overlap in order to limit the competition in the market. Promoters of an Arctic satellite system, whether they are private companies or government institutions, would like to maximize the overlap in order to improve the business case of the project. The coverage requirements for broadcasting, broadband and backhaul services are defined as the area above 70° northern latitude. This is shown with the solid yellow circle in Figure 2.1.

Reliable distress and safety services are required above 76° North. Overlap with Inmarsat's GEO based GMDSS service is necessary. The distress and safety

services should be integrated into the regular broadband and broadcasting services. It is logical to use the same coverage requirements as the one defined for those services. Distress and safety coverage requirements are defined as the area above 70° northern latitude.

An extended coverage area reaching down to 60° northern latitude has also defined. It is indicated with the dotted yellow circle in Figure 2.1. This larger area will make it possible to capture a larger market. The area between 60° and 70° North is also more populated and have a higher traffic density. At these latitudes, an Arctic communications system can complement GEO based solutions, and offer satellite service providers spare capacity. It can also service users that are located in GEO shadow. Such an extended coverage area will also make a satellite based communications system for the Arctic able to handle seasonal traffic variations.

2.4 Service definitions

Based on the preceding discussions it is possible to define the services to be provided by an Arctic satellite communications system. According to the requirements, services provided by the system are limited to broadcasting, broadband and backhaul as well as distress and safety services.

2.4.1 Broadcasting

Broadcasting services are fairly straight forward to implement through a transparent satellite payload configuration. Transponders and frequency spectrum are allocated to broadcast services for a longer period of time with transmission in only one direction. The content is coded and modulated appropriately at a central gateway or hub and sent up to the satellites. In the satellites, the radio signal is received, amplified and retransmitted down to earth. In section 2.1, the capacity requirement for an Arctic broadcasting service was set to be between 20 and 30 Television (TV) channels. Based on this it is assumed that 30 channels should be provided, and that 10 of these channels should be High Definition Television (HDTV) channels. A high rate HDTV channel can require a bit rate up to 15 Mbit/s while a Standard Definition Television (SDTV) channel need up to 4 Mbit/s. Therefore, the total bandwidth required to support the broadcast service requirements are around 230 Mbit/s.

2.4.2 Broadband

It is more challenging to implement broadband services via satellite than broadcast services. As an interactive service, it requires two-way communications. The forward direction has many similarities with a broadcast service, but the return channel pose challenges. Small user terminals can not provide the same uplink power on the return link as large gateway stations provide on the forward uplink. Thus, the capabilities of the forward and the return links in a satellite communications system are asymmetrical. Typically, users download more data than they upload so the mismatch can be managed in a satisfactory way, but it does impact how satellite capacity and resources can be utilized.

Another challenge with satellite broadband services is varying traffic volume over time. Short term variations occur as users are not transmitting and receiving data continuously. Medium term variations are caused by different usage patterns during daytime and nighttime as well as weekends and other holidays. Long term variations are due to seasonal differences in user types and density within the coverage area. An Arctic system must be expected to see a significantly higher traffic volume during the summer months compared to winter time. Seasonal variations in traffic volume might lead to satellite capacity being unused for longer periods of time. With a geographically flexible resource allocation, it is possible to mitigate the long term variations by moving payload capacity north and south as the seasons and traffic density changes.

With a high number of users, the short term variations can be expected to even out. The result is a fairly stable total traffic volume. However, if all users are assigned a fixed bandwidth, the system must be designed with a higher capacity than the stable traffic volume. Therefore, it is more cost efficient to implement a multiple access scheme where the users share a bandwidth pool. Bandwidth can then be dynamically allocated to users according to their transmission needs. Dynamic capacity allocation can be done through assignment of time slots in a Time Division Multiple Access (TDMA) based scheme or allotment of a frequency channel for a limited period in a Frequency Division Multiple Access (FDMA) based scheme. In the forward direction, the central gateway or hub will coordinate the data traffic and assign capacity as needed.

The return direction is more challenging as the traffic is generated by a distributed number of users. Before a user terminal can transmit data it has to be assigned a frequency channel or time slot, depending on the multiple access scheme employed. User terminals send a request or demand for allocation of capacity to the central gateway or hub, which in turn assign capacity based on

Table 2.2: Broadband service levels suggested for Arctic communications coverage.

Service level	Uplink speed [Mbit/s]	Downlink speed [Mbit/s]
A	0.5	1.0
B	1.0	2.0
C	2.0	4.0
D	4.0	8.0

availability and transmission requests from other users. This form of capacity allocation is usually referred to as Demand Assigned Multiple Access (DAMA) and is frequently used in satellite communications applications. The requests for assignment of capacity are sent on a separate control channel. These request messages should have a standardized format and length, allowing an effective use of a random access protocol.

The area covered by the communications system will have various types of broadband users with different service requirements. Therefore, it is necessary to establish a set of service levels. Currently, the VSAT market is dominated by solutions that offer downlink bit rates between 1 Mbit/s and 4 Mbit/s, and uplink bit rates between 0.5 Mbit/s and 2 Mbit/s. Solutions with higher bit rates are also available, and their popularity in the market place is expected to increase in the future. An entry level service providing 0.5 Mbit/s uplink speed and 1 Mbit/s downlink speed should, therefore, be available from an Arctic satellite communications system. Two or three additional service levels providing higher bandwidths should also be accommodated for in the system. Table 2.2 show service levels and bit rates suggested for the system studied here. As the technology evolve and requirements change, a flexible and transparent payload configuration will allow appropriate adaption of the service levels.

2.4.3 Backhaul

An adequate backhaul service is important for small communities and settlements in the high North. Instead of installing broadband user terminals in every household a common backhaul communications link can serve the whole community. The backhaul link will aggregate and transfer a variety of traffic between a settlement and the rest of the world. Backhaul traffic includes services such as telephony, file transfer and internet surfing.

Table 2.3: Backhaul service levels suggested for Arctic communications coverage.

Service level	Uplink speed [Mbit/s]	Downlink speed [Mbit/s]
A	20	20
B	10	10

There are many similarities between backhaul and broadband services, and the distinction between them can in some cases be difficult to see. A high performance broadband link can sometimes be used as a backhaul solution, and users with high bit rate requirements can use a backhaul service to meet their communication needs. A communications satellite with a bent pipe payload can support both backhaul and broadband, and satellite resources can be moved between these two services according to the demand.

Earth stations intended for support of backhaul services will typically be more powerful and have a larger antenna than broadband user terminals. The increased earth station performance allow for a higher throughput, especially on the return link. Therefore, a balanced service supporting the same transmission speed on the return link and the forward link should be possible. This is useful since backhaul services normally are more synchronous than broadband traffic.

Two standard backhaul services are suggested to be implemented; a high rate solution supporting 20 Mbit/s on both uplink and downlink, and one supporting a lower rate of 10 Mbit/s in both directions. These are summarized in Table 2.3. With such bit rates, this service type will also be of interest for oil exploration and production facilities as it may allow Integrated Operations (IO). Backhaul earth stations are assumed to have a stable traffic load. Therefore, satellite capacity should be allocated to each backhaul earth station on a fixed basis. A fixed capacity assignment does not mean it can not be reallocated with changing demand over time, but the earth stations do not need to send a request for capacity before transmitting. A backhaul earth station has constant access to its assigned capacity, regardless of the traffic load on the communications link.

The stable traffic load combined with larger antennas and more powerful terminal equipment at backhaul earth stations allow the use of efficient transmission schemes on the return link. It should be possible to use similar, if not the same, techniques in terms of coding, modulation and framing structure as on the forward link. This will increase the cost of backhaul earth stations.

However, in the Arctic there will be a limited number of such stations, and not a mass market. Therefore, it is sensible to spend resources on the earth stations in order to utilize the satellite payload as efficiently as possible.

2.4.4 Distress and safety

Distress and safety services have very high availability and reliability requirements. In times of distress, it can be crucial to have an available communications link, regardless of weather. It should also be possible to send emergency messages without requiring accurate pointing of a highly directive antenna. This is partly why Inmarsat use L band for their GMDSS approved distress and safety services. A distress and safety service is inherently a narrowband service. Therefore, it might therefore be possible to find usable frequency allocations at a low frequency, such as L or S band. However, a powerful distress and safety payload in L or S band will drastically increase the system complexity, resulting in larger and heavier satellites with a substantially higher cost.

Possibilities for integration of distress and safety services into the regular broadband and broadcasting services at either K_u or K_a band should, therefore, be explored. Distribution of GMDSS information such as Navigation Telex Radio (NAVTEX) can be provided as part of the broadcasting service. A solution for emergency calling could form part of the broadband service. Issues with availability can be handled by the provision of a narrowband and low bit rate channel taking advantage of a robust coding and modulation scheme providing a high link margin.

Chapter 3

Orbit considerations

When designing a satellite communications system the choice of orbit is crucial. Coverage and availability are paramount to the success of a satellite system. A state of the art satellite communications system is without value if it does not cover the areas of interest or has the necessary availability. Careful consideration and selection of orbital parameters are needed to find the optimal solution, both in single satellite systems and systems using constellations of multiple satellites.

In this chapter, the orbit needed for an Arctic satellite communications system is considered. The attention is given to HEO alternatives. Promising orbit alternatives and constellations are discussed, and their main properties are presented. The chapter concludes with several promising constellation alternatives that are further considered and refined in Chapter 4.

3.1 High Elliptical Orbit

The dwell time of HEO satellites increases with the eccentricity. With appropriate orbital period, eccentricity and inclination a HEO satellite can be quasi-stationary for several hours. However, due to the earth's oblateness the apogee position will drift. The higher gravitational pull around equator will advance the apogee of low inclination orbits. Around the poles the gravitational pull is weaker, thus, the apogee rotates backwards in high inclination orbits. At an inclination of 63.4° , the net result is no apogee drift. This inclination is often referred to as the critical inclination. Other inclinations can also be

used, but then frequent orbit maneuvers and corrections are necessary to keep the apogee location stable.

With a repeating ground track, a satellite in a critically inclined HEO will have its apogee position, or positions, at the same place orbit after orbit. A constellation of such satellites can then provide continuous and quasi-stationary coverage from a limited number of apogee positions. The number of apogee positions depend on the orbital period and satellite constellation design. A satellite orbit has a repeating ground track when it has an integral number of orbits in an integral number of sidereal days. To be quasi-stationary, the apogee altitude must be in the same order of magnitude as the altitude of GEO satellites. As a result, orbits with a period close to 12 h, 16 h, 18 h and 24 h are the most interesting, and are able to provide quasi-stationary coverage of the Arctic from one or more apogee locations. These orbit alternatives have been widely discussed in relation to Arctic and high latitude coverage [1, 4–14].

High eccentricity seems advantageous for a HEO. To some extent this is true, but there are bounds on the eccentricity dependent on the orbital period. This is illustrated in Figure 3.1, where eccentricity is plotted against orbital period. The shaded area denotes invalid combinations of eccentricity and orbit period. A minimum perigee altitude of 500 km is selected in order to reduce orbit maneuvers necessitated by atmospheric drag. In Figure 3.1, this eccentricity boundary is indicated by the blue line. It is also assumed necessary to limit the apogee altitude to ensure system compatibility with GEO based communications systems. A 50 % increase in altitude from GEO is set as a maximum apogee altitude. This corresponds to a maximum apogee altitude of 54 000 km and gives the black boundary line in Figure 3.1. By only allowing a 50 % higher apogee altitude compared to GEO altitude, the increase in free space loss is limited to 3.5 dB when referenced to the sub-satellite points.

Lower eccentricity boundaries can be found from coverage requirements. The red line in Figure 3.1 indicates the minimum eccentricity needed for a HEO satellite in a critically inclined orbit to be available in at least 50 % of the time above 60° North. With a constellation of two satellites, that would allow for continuous coverage of that area. The green line illustrates the same, but with a satellite availability of 33.3 % which is needed with a constellation of three satellites. These eccentricity requirements can be reduced if the inclination is increased above 63.4°. In the following sections presentations of the four orbital period alternatives, 12 h, 16 h, 18 h and 24 h, are given along with a brief discussion of their main properties. A summary of these properties is found in table 3.1.

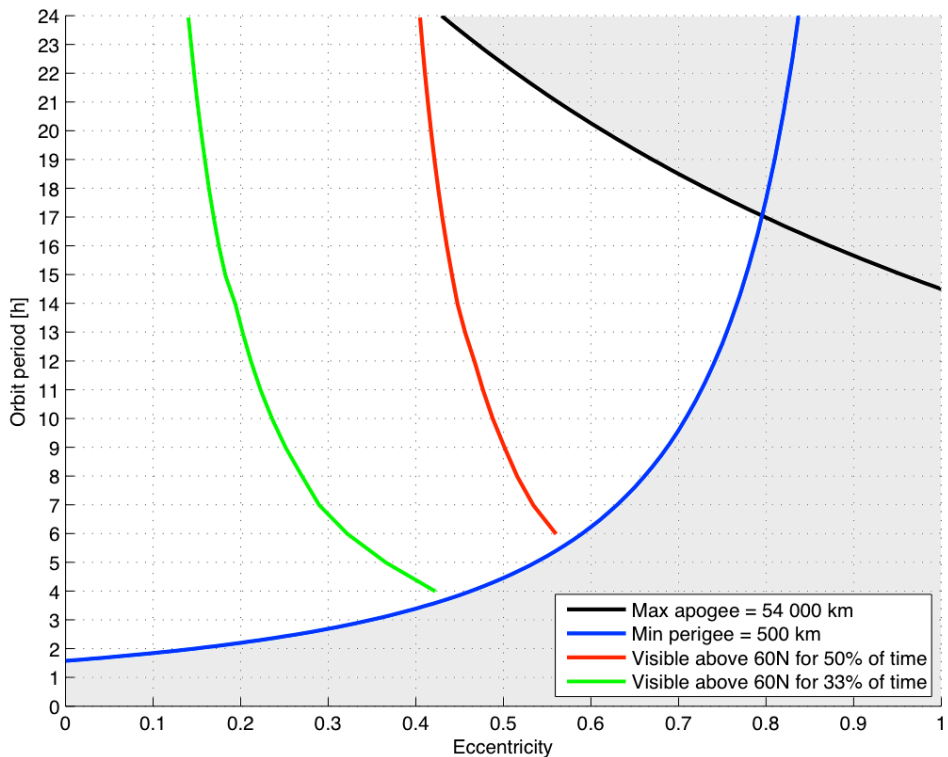

Figure 3.1: Orbital period dependent eccentricity bounds, with invalid combinations in the shaded area. The blue line indicate maximum eccentricity based on a minimum perigee altitude of 500 km. The black line indicate a maximum eccentricity based on a maximum apogee altitude of 54 000 km. The red line show the minimum eccentricity that provide coverage 50 % of the time above 60° North when the orbit inclination is 63.4°. The green line show the same as the red, but with coverage only 33.3 % of the time.

Table 3.1: Summary of the properties of the various HEO alternatives. Apogees indicate the number of apogees the ground track of the various orbits have. The columns marked $> 1/2$ and $> 1/3$ show the minimum eccentricity necessary for a critically inclined satellite to be visible more than 50 % and 33.3 % of the time.

Orbit	Period [h]	Apogees	Eccentricity			Apogee range [km]
			max	$> 1/2$	$> 1/3$	
12 h	11.9672	2	0.7412	0.4673	0.2120	25 820 - 39 876
16 h	15.9563	3	0.7864	0.4356	0.1754	31 448 - 51 108
18 h	17.9509	4	0.7346	0.4258	0.1641	34 144 - 54 000
24 h	23.9345	1	0.4319	0.4048	0.1404	41 711 - 54 000

3.1.1 12 hour orbit

The 12 h orbit has a period equal to half a sidereal day, which is 11 h, 58 min and 2 s. A satellite in such an orbit will complete two revolutions a day. Thus, the orbit gives a repeating ground track with two apogee positions relative to the earth. These two apogee positions will be separated 180° in longitude. Maximum eccentricity for the 12 h orbit bounded by a minimum perigee altitude of 500 km is 0.7412. Assuming critically inclined satellites, the minimum eccentricity that can give continuous coverage above 60° North is 0.4673 and 0.2120 for constellations of 2 and 3 satellites respectively. This eccentricity span results in apogee altitudes between 25 820 km to 39 876 km.

Interesting alternatives using satellites in the 12 h orbit include both constellations of two and three satellites. Two satellites launched into the same plane can provide continuous coverage of the Arctic from four apogee locations spaced 90° apart. If two satellites are launched into individual planes with Right Ascension of the Ascending Node (RAAN) 90° apart, they will use the same two apogee locations relative to earth. Constellations of three satellites will be able to provide continuous coverage of the Arctic from two of the satellites. If launched in to individual planes with RAAN 120° apart, they will use only two apogee locations relative to earth, and both will be populated by a satellite at all times. A constellation of three satellites launched in the same orbital plane will have six apogee locations. As it has many apogee locations, this last alternative is less attractive than the other three constellation alternatives.

3.1.2 16 hour orbit

When adjusted to coincide with the sidereal day, the orbital period of the 16 h orbit is 15 h, 57 min and 23 s. With three revolutions in two days, such a satellite will have a repeating ground track with three apogee locations relative to earth. The apogee positions are spaced 120° apart in longitude. The minimum perigee altitude of 500 km allows a maximum eccentricity for the 16 h orbit of 0.7864. For a critically inclined satellite to be visible above 60° North 50% of the time, the eccentricity must be higher than 0.4356. Visibility 33.3% of the time is achieved with eccentricity down to 0.1754. Therefore, possible apogee altitudes for the 16 h orbit range from 31 448 km to 51 108 km.

Two 16 h orbit satellites can provide continuous coverage of the Arctic with three apogee locations evenly distributed 120° apart in longitude. Launched

into the same orbital plane and spaced 180° in the plane, they will have the same ground track, but never enter and exit the same apogee location. With two satellites launched into individual planes with RAAN 120° their ground track will be identical, and they will enter and exit the same apogee location every other handover.

A constellation of three satellites can allow continuous access to two satellites. However, which apogee locations these two satellites are in, will change every time one satellite enters and another exits the coverage area. Thus, a constellation of three satellites is not as advantageous with 16 h orbits as with 12 h orbits. Interesting constellation alternatives using 16 h orbits are, consequently, with two satellites in either single or individual planes.

3.1.3 18 hour orbit

The 18 h orbit has an orbital period of 17 h, 57 min and 3 s when coinciding with the sidereal day. In three days, a satellite in an 18 h orbit will complete four revolutions. This creates a repeating ground track with four apogee locations relative to earth spaced evenly 90° apart in longitude. Maximum eccentricity for the 18 h orbit is limited by the maximum apogee altitude of 54 000 km and is 0.7346. A critically inclined satellite in an 18 h orbit will be visible north of 60° latitude for more than 50 % of the time when the eccentricity is larger than 0.4258. An eccentricity of 0.1641 will give satellite access in the same area for 33.3 % of the time. The resulting apogee altitude span is from 34 144 km to 54 000 km.

Continuous coverage of the Arctic is possible using a constellation of two satellites in 18 h orbits. With the satellites launched into the same orbital plane, the satellites will use as much as eight different apogee locations spaced 45° apart in longitude. By putting the satellites into individual orbital planes with RAAN 135° apart, the number of apogee locations is reduced to four. As for the 16 h orbit, a constellation of three satellites will allow continuous access to two satellites in the Arctic, but from changing apogee locations. Thus, 18 h orbits are assumed to be of interest only in constellations using two satellites.

3.1.4 24 hour orbit

The 24 h orbit has a period equal to one sidereal day. Thus, a satellite in such an orbit completes a revolution in 23 h 56 min and 4 s, the same as a

GEO satellite. As a result, a satellite in a 24 h orbit will only have one apogee location relative to earth. A maximum apogee altitude of 54 000 km limits the maximum eccentricity to 0.4319. Single satellite availability 50 % of the time above 60° North can be achieved with a critically inclined satellite when the eccentricity is above 0.4048. For satellite access 33.3 % of the time in this area, an eccentricity of only 0.1404 is required. This eccentricity span gives possible apogee altitudes in a range from 41 711 km to 54 000 km.

Constellations of both two and three satellites are of interest if 24 h orbits are used. Two satellites launched in the same orbital plane will use two apogee locations 180° apart in longitude to provide continuous coverage. For two satellites to use the same apogee, their orbital planes must have RAAN separated by 180°. If three satellites are launched in the same plane, their three different apogee locations will be spaced 120° apart. The three satellites will use the same apogee location if they are in individual orbital planes with RAAN 120° apart. A constellation of three satellites in 24 h orbits will not be able to provide double coverage such as three satellites in 12 h orbits can. There might still be advantages with the possibly reduced eccentricity three satellites in 24 h orbits can have, when compared to a constellation of two satellites. Thus, for 24 h orbits constellations of two and three satellites are of interest, both with single and individual orbital planes.

3.2 Orbit conclusions

Satellite orbits with high eccentricity and suitable orbital period are able to provide quasi-stationary satellite conditions with similar satellite altitudes as GEO satellites. Continuous coverage is possible with only two satellites, but there might be advantages to adding a third satellite. Following the arguments of the previous sections, constellation alternatives that are given a closer look in the next chapters include two and three satellites in 12 h orbits, two satellites in 16 h orbits, two satellites in 18 h orbits as well as two and three satellites in 24 h orbits. This is shown in table form in Table 3.2. The effect of various orbital parameters on coverage and system design will be addressed. Two examples of such orbital parameters are eccentricity and inclination.

Table 3.2: Summary of the most promising constellation alternatives.

Orbit	Constellation alternatives			
	2 satellites		3 satellites	
	Same plane	Individual plane	Same plane	Individual plane
12 h	✓	✓		✓
16 h	✓	✓		
18 h	✓	✓		
24 h	✓	✓	✓	✓

Chapter 4

Design of constellation alternatives

Adjustment of the orbital parameters of the satellites in a constellation can change the coverage and availability of the system. For a given orbital period, the two most important orbital parameters when designing a HEO constellation are inclination and eccentricity. These two parameters have an impact on how the Arctic is covered and at which elevation angles. They are also important for availability of services and the shape of the satellite ground track.

In the following sections, adjustment of these two orbital parameters are investigated. The effect of their adjustment is studied, and the findings are used to optimize the constellation alternatives identified in Chapter 3. Fifteen constellation alternatives are then defined with appropriate orbital parameters.

4.1 Orbital inclination

Satellite orbits will be perturbed. One source for orbit perturbations is the non-spherical earth. From the gravity potential of the earth, gravity harmonics can be derived. These gravity harmonics can then be used to describe how a satellite orbit is perturbed from the ideal Kepler orbit by the irregular gravity of the earth. The largest perturbing influence comes from the oblateness term, which is the second order harmonic often referred to as J_2 . Orbital elements such as the RAAN, the argument of perigee and orbit mean motion are influenced by J_2 [11, 15].

The exact effect the second order harmonic have on these orbital parameters depend on inclination, eccentricity and the semimajor axis. For HEO satellites, the effect on the right ascension of the ascending node and orbit mean motion can be controlled by small adjustments of the orbital period. For a satellite in a 12 h HEO, the orbital period adjustment necessary to control the change of these two parameters is less than 20 s [9].

4.1.1 Perigee drift

A HEO based satellite communications system for the Arctic is only effective if the satellite apogee is located above the Arctic. The argument of perigee denotes where in the orbital plane the perigee, and hence the apogee, is. For the apogee of a HEO to be above the Arctic, the argument of perigee must be 270° . However, due to the perturbations caused by the second order gravity harmonics the argument of perigee, ω , is drifting. This drift, $\Delta\omega$, can be expressed by the following equation:

$$\Delta\omega = \frac{\delta\omega}{\delta t} = \frac{3}{2}J_2n \left(\frac{R}{a(1-e^2)} \right)^2 \left(2 - \frac{5}{2}\sin^2(i) \right) \quad (4.1)$$

where J_2 is 1.08263×10^{-3} , R is the earth equatorial radius, a is the semi-major axis, e is the eccentricity, n is the orbit mean motion and i is the inclination [15].

From Eq. 4.1, it can be observed that if the expression inside the last parenthesis is zero, the perigee drift will also be zero. When solved for i , this leads to the critical inclination of 63.435° . An inclination of 116.565° will also result in zero perigee drift, but that is a retrograde orbit. Thus, due to lower ground speed and better apogee conditions the inclination of 63.435° is preferred for an Arctic satellite system [9, 11, 15].

The critical inclination of 63.435° has been used by most HEO systems in the past. Examples include the russian Molniya satellites and the american Sirius Satellite Radio satellites. However, it is possible to use an inclination higher than the critical inclination. A higher inclination will improve the coverage of a HEO system and increase the elevation angles from users to a satellite, but will require regular orbit maneuvers to keep the apogee fixed. The coverage improvement is terms of a larger area where at least one satellite is visible at all times. In Figure 4.1, this improvement is illustrated for a constellation using two satellites in 12 h orbits, individual orbital planes and eccentricity of 0.72.

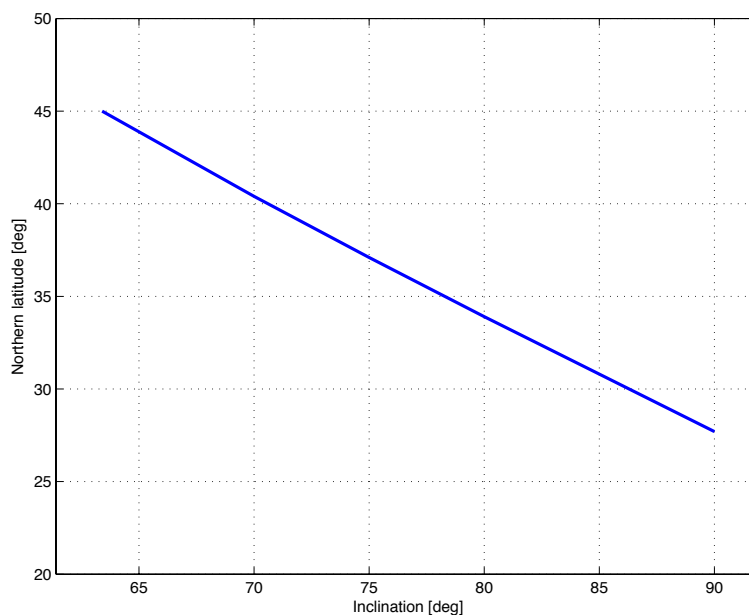

Figure 4.1: Coverage improvement as inclination increases for a constellation of two 12 h HEO satellites in individual orbital planes and eccentricity of 0.72. The line shows at which latitude 100% coverage is possible for a given inclination.

In section 2.3, the coverage area requirements for this system were defined as the area north of 70° northern latitude. Figure 4.1 shows that for the constellation used in this example, the coverage requirement is more than adequately met without increasing the inclination above 63.435°. Thus, for a typical 12 h HEO constellation there is limited gain in increasing the inclination. However, the constellation alternatives using longer orbital periods may benefit from an inclination above 63.435°. Therefore, it is appropriate to have a closer look at how the perigee drift is influenced by the inclination, and how the necessary stationkeeping impact satellite operations.

From Eq. 4.1, the drift of the argument of perigee can be calculated. The contours in Figures 4.2-4.5 show the yearly perigee drift given in degrees as a function of eccentricity and inclination for the four orbital period alternatives, 12 h, 16 h, 18 h and 24 h. From these figures, it can be observed that increasing eccentricity and inclination lead to a larger perigee drift. It should also be noted that the magnitude of this effect is decreasing with increasing orbital period. Close inspection reveals that the shape of the contours is only dependent on the eccentricity and inclination while the magnitude is given by the orbital period. A satellite in a 16 h orbit will experience 51.1% of the

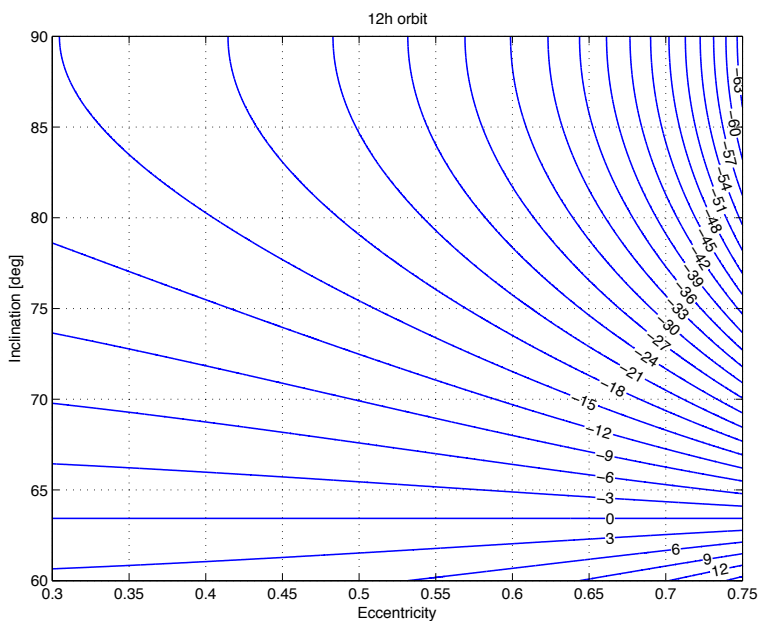

Figure 4.2: The perigee drift in degrees per year for a 12 h HEO orbit as a function of eccentricity and inclination.

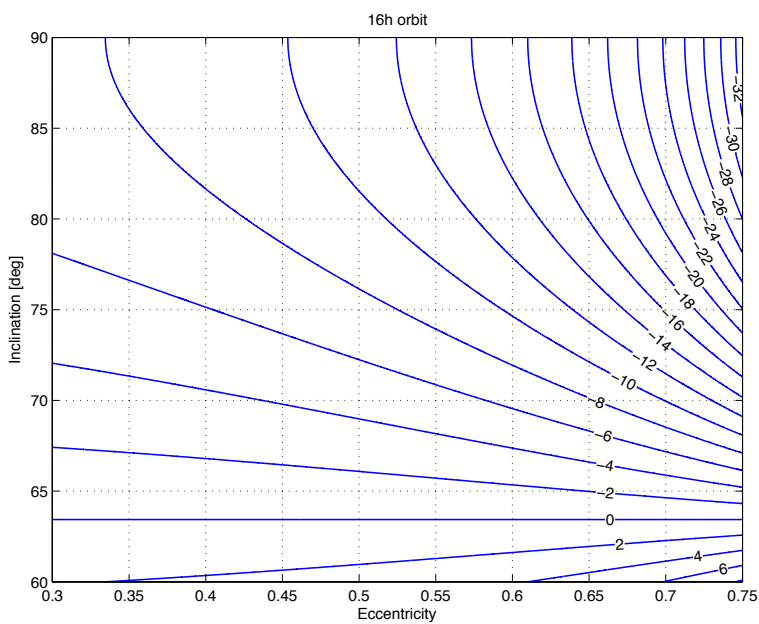

Figure 4.3: The perigee drift in degrees per year for a 16 h HEO orbit as a function of eccentricity and inclination.

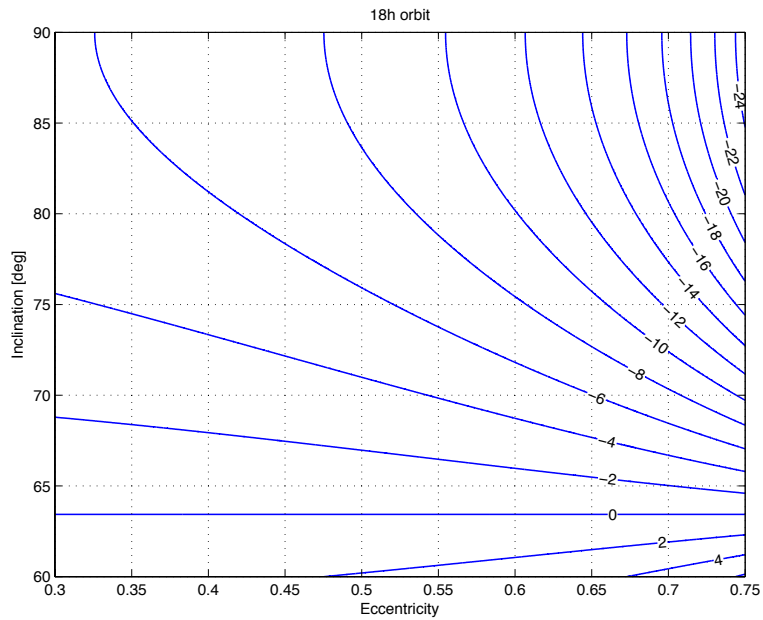

Figure 4.4: The perigee drift in degrees per year for a 18 h HEO orbit as a function of eccentricity and inclination.

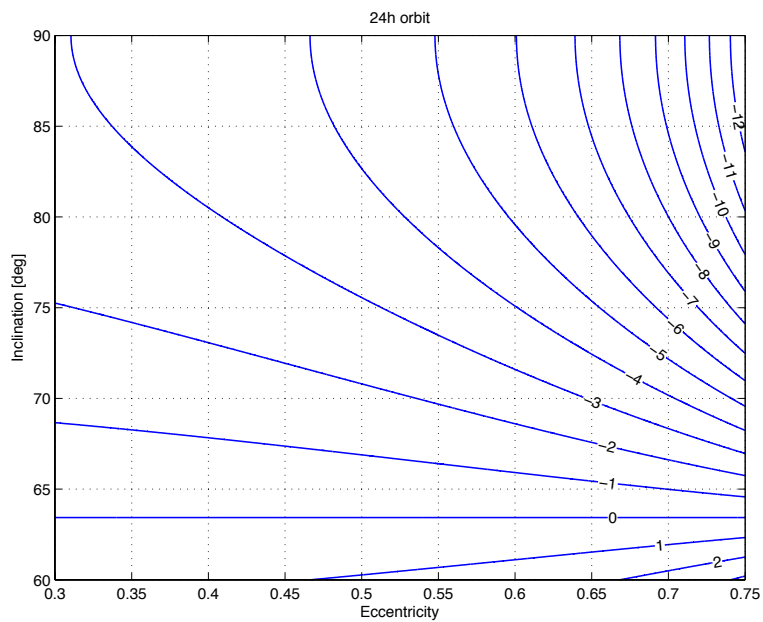

Figure 4.5: The perigee drift in degrees per year for a 24 h HEO orbit as a function of eccentricity and inclination.

perigee drift a satellite in 12 h orbit with the same inclination and eccentricity will experience. For satellites in 18 h and 24 h orbits, this number is 38.8% and 19.8% respectively.

4.1.2 Compensating for perigee drift

The perigee drift figures found are substantial, especially in the eccentricity range of interest for the 12 h and 16 h orbits. However, the apogee can be kept stable by orbit maneuvers compensating the perigee drift. Therefore, it is necessary to find the effect which the perigee drift will have on the ΔV budget.

To correct the perigee drift, it is necessary to perform a coplanar transfer from the perturbed to the desired orbit. With a single impulse maneuver, the transfer can be executed at either of the two intersections between the perturbed and the desired orbit. However, the optimal approach is to use a two-impulse maneuver. The first impulse is applied at $v_1 = 90 + \Delta\omega/2$, and the second is applied 180° away. The additional velocity, ΔV , required can be expressed by the following equation:

$$\Delta V = e \sqrt{\frac{\mu}{a(1-e^2)}} \sin\left(\frac{\Delta\omega}{2}\right) \quad (4.2)$$

where μ is the gravitational constant of the earth and $\Delta\omega$ is the desired change in argument of perigee [15, 16].

In order to ensure optimal performance of a HEO satellite communications system, the argument of perigee should be kept inside a certain interval. GEO satellites are usually kept inside a box less than 0.05° away from the nominal position. The satellites in a HEO system can be allowed to wander more as they are not stationary anyway, but not by much to ensure limited variation in satellite positions over time. Thus, orbit maneuvers must be performed regularly. As a result, the change in argument of perigee, $\Delta\omega$, during an orbit maneuver will be very small. The expression in Eq. 4.2 can, therefore, be approximated and simplified to:

$$\Delta V \approx \Delta\omega \frac{e}{2} \sqrt{\frac{\mu}{a(1-e^2)}} \quad (4.3)$$

where $\Delta\omega$ is in radians [10]. As this is a linear expression, all the small individual argument of perigee corrections can be summed into on yearly $\Delta\omega$. Therefore,

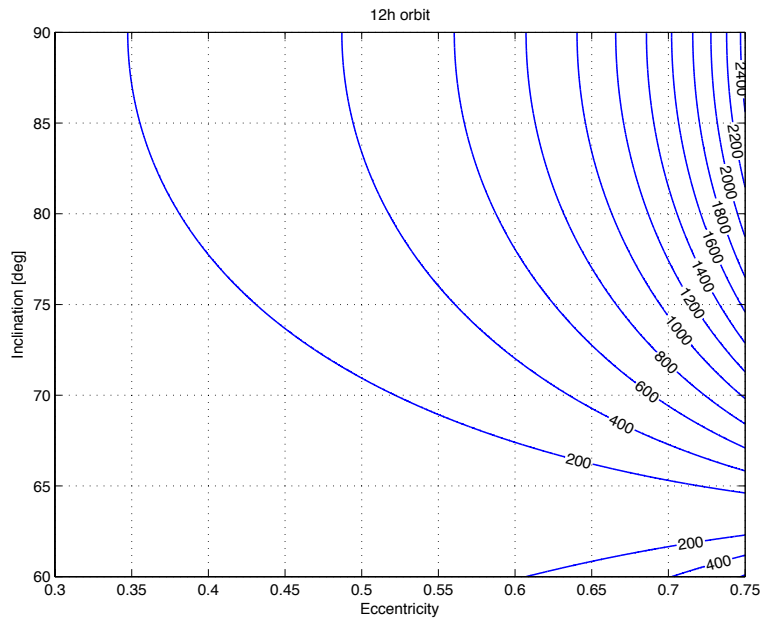

Figure 4.6: Additional velocity, ΔV , in m/s per year necessary to keep the apogee of a 12 h HEO satellite fixed as a function of inclination and eccentricity.

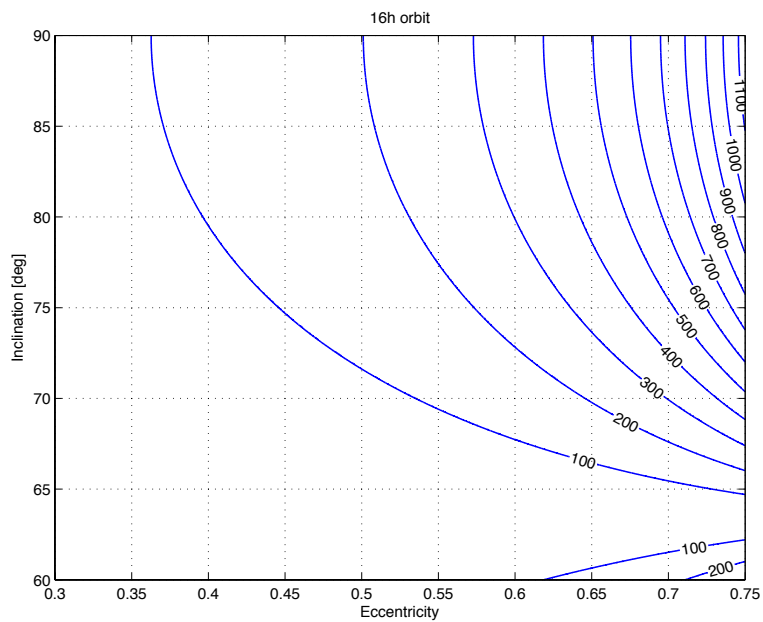

Figure 4.7: Additional velocity, ΔV , in m/s per year necessary to keep the apogee of a 16 h HEO satellite fixed as a function of inclination and eccentricity.

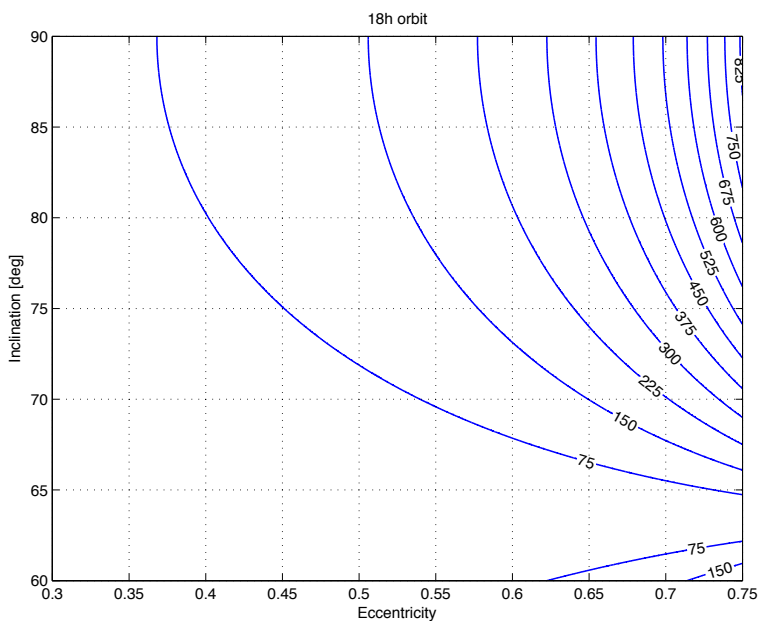

Figure 4.8: Additional velocity, ΔV , in m/s per year necessary to keep the apogee of a 18 h HEO satellite fixed as a function of inclination and eccentricity.

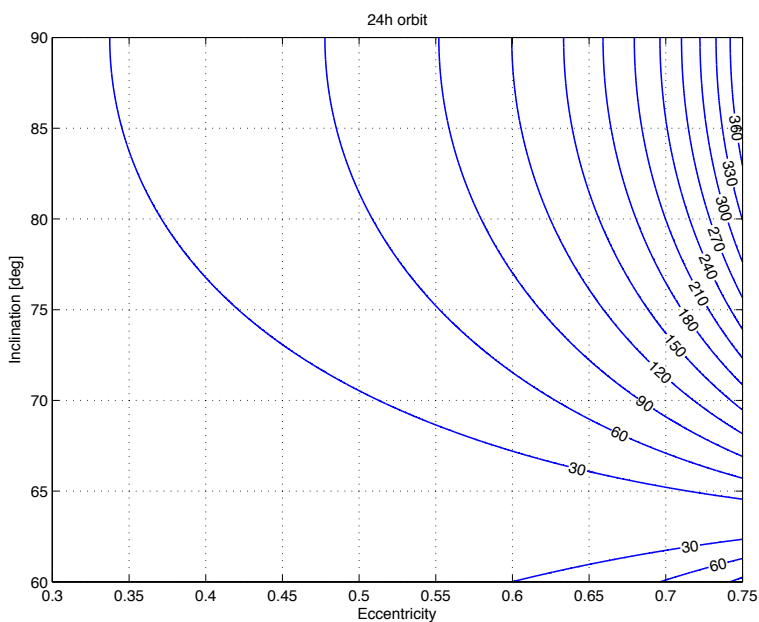

Figure 4.9: Additional velocity, ΔV , in m/s per year necessary to keep the apogee of a 24 h HEO satellite fixed as a function of inclination and eccentricity.

the expression in Eq. 4.3 can be used to calculate the additional velocity, ΔV , necessary to keep the apogee of a HEO satellite fixed.

Results of Eq. 4.3 for the four alternative orbital periods are shown in Figures 4.6-4.9. The contours indicate the ΔV in m/s per year necessary to ensure fixed apogee as a function of eccentricity and inclination. As expected, the ΔV has the same trend as the $\Delta\omega$ and increases with higher eccentricity and inclination while it decreases with a larger orbital period.

Furthermore, the shape of the contours are also for ΔV only dependent on eccentricity and inclination. The orbital period has an impact on the magnitude of ΔV for a given eccentricity and inclination. Thus, the ratio between the ΔV necessary for ensuring fixed apogee for the four alternative orbital periods is constant when the eccentricity and inclination are the same. Since the semi major axis is a variable in Eq. 4.3, the difference in necessary yearly ΔV will be larger than the difference in yearly $\Delta\omega$. A 16 h HEO satellite needs only 46.4 % of the ΔV which a 12 h HEO satellite needs to keep the apogee fixed. For 18 h and 24 h HEO satellites that figure is 33.9 % and 15.8 % respectively.

These values assume the satellite has the same eccentricity and inclination. However, an increased orbital period makes it possible to provide the required coverage with a reduced eccentricity. Thus, in reality the difference in necessary yearly ΔV between the four alternatives will be even larger.

4.1.3 Effect on satellite maneuver lifetime

The ΔV values found here for HEO satellites can be put into perspective by a comparison with ΔV usage of GEO satellites. A typical GEO satellite requires a ΔV of 50 m/s to 55 m/s per year for stationkeeping [11, 15]. It is assumed that a HEO satellite will require the same ΔV as a GEO satellite to correct inclination drift and other perturbations except the J_2 effect. It is also assumed that the satellite platform used in a HEO satellite communications system is a modified version of a typical GEO satellite platform.

In such a scenario, the ΔV required to correct for the J_2 effect will directly reduce the maneuver lifetime of a HEO satellite compared to GEO and critically inclined HEO satellites. Figures 4.10-4.13 illustrate the effect corrected perigee drift will have on satellite maneuver lifetime when the inclination is not 63.435° . The contours in the figures show the maneuver lifetime for a certain eccentricity and inclination in percent of the maneuver lifetime the same satellite can have in a GEO or critically inclined HEO.

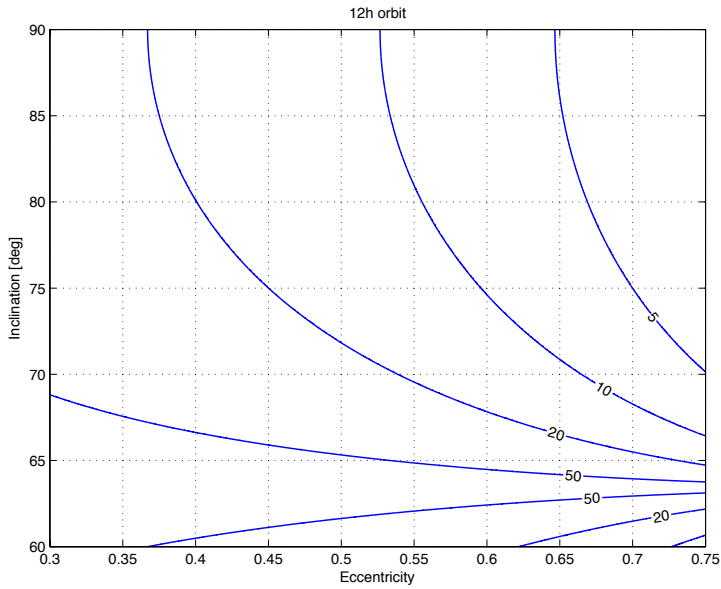

Figure 4.10: Satellite maneuver lifetime of 12 h HEO in percent of the maneuver lifetime the same satellite can have in a GEO or critically inclined HEO as a function of eccentricity and inclination.

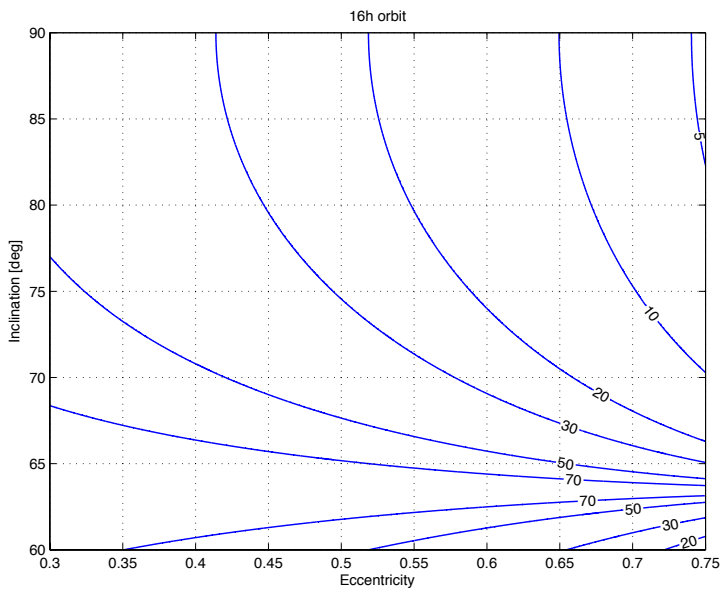

Figure 4.11: Satellite maneuver lifetime of 16 h HEO in percent of the maneuver lifetime the same satellite can have in a GEO or critically inclined HEO as a function of eccentricity and inclination.

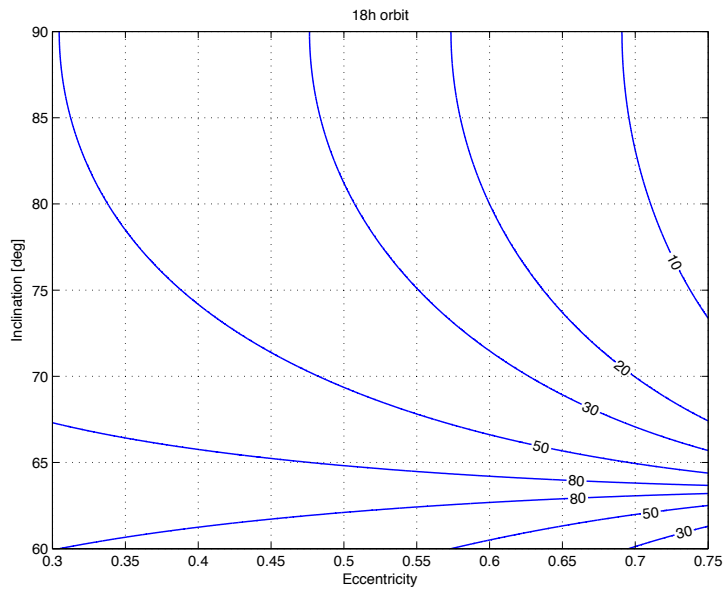

Figure 4.12: Satellite maneuver lifetime of 18 h HEO in percent of the maneuver lifetime the same satellite can have in a GEO or critically inclined HEO as a function of eccentricity and inclination.

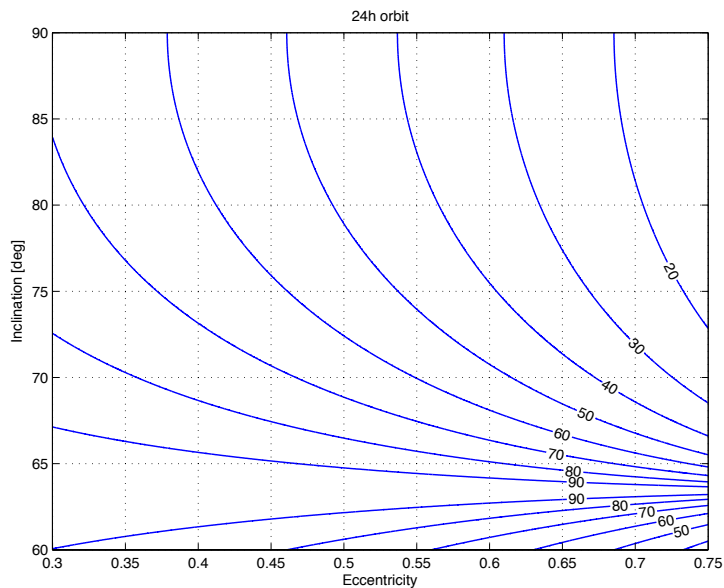

Figure 4.13: Satellite maneuver lifetime of 24 h HEO in percent of the maneuver lifetime the same satellite can have in a GEO or critically inclined HEO as a function of eccentricity and inclination.

Figure 4.10 shows that the satellite maneuver lifetime of a 12 h HEO is substantially reduced even with a small offset from 63.435° inclination. Based on that, the critical inclination is the only viable inclination for a 12 h HEO system. The effect the perigee drift has on the satellite maneuver lifetime of a 16 h HEO, is less than for the 12 h alternative, but still substantial. Other studies have assessed that an inclination of 70° is manageable [10]. However, based on the results shown in Figure 4.11 the reduction in satellite maneuver lifetime will be significant. For the 16 h orbit alternative, only a constellation using critically inclined orbits is viewed as cost efficient. The situation for the 18 h orbit alternative is even better than for the 16 h orbit alternative. Nevertheless, within the eccentricity range of interest, the reduction in satellite maneuver lifetime indicted in Figure 4.12 is quite large. Therefore, an inclination higher than 63.435° is not viewed as a good idea for the 18 h HEO constellations either.

The larger orbital period of the 24 h orbit is less influenced by the perigee drift, and it is less demanding to correct perturbations. In addition, the eccentricity range of interest for the 24 h orbit alternative is much lower than for the three other alternatives. That has a positive effect on the ΔV budget and improves the satellite maneuver lifetime. In Chapter 3, the maximum allowed eccentricity for the 24 h orbit was found to be 0.4319. From Figure 4.13, it can be estimated that a satellite in a 24 h orbit with that eccentricity and 90° inclination will have a satellite maneuver lifetime of about 55 % of a GEO satellite. That is still a significant decrease in satellite maneuver lifetime, but the increased inclination will allow for improved coverage with a reduced eccentricity. A reduction in eccentricity will improve the maneuver lifetime up from 55 % and potentially make it acceptable.

Therefore, based on these findings the 24 h HEO constellations using other inclinations than 63.435° should be considered together with the critically inclined HEO constellations using two satellites. Figure 4.1 indicate that the coverage improvement in terms of lowest latitude covered has a fairly linear relationship with the inclination. In that example, a 12 h HEO constellation was used as an example, but it can be expected that a 24 h HEO constellation will be affected by increased inclination in the same manner. With this in mind, two inclination alternatives along with the critical inclination have been chosen for further studies of 24 h HEO constellations. The first has a 90.0° inclination, as that will maximize the coverage and provide the highest elevation angles. The second has a 75.0° inclination, because it is almost evenly spaced between 63.435° and 90.0° .

From the above discussion and calculations it can be concluded that the crit-

ical inclination of 63.435° is the only viable inclination for HEO constellations using 12 h, 16 h and 18 h orbits. Increasing the inclination above 63.435° has limited advantages and it significantly reduces satellite maneuver lifetime due to the need for orbit corrections to keep the apogee stable. HEO constellations using 24 h orbits may benefit from increased inclination, and the reduced maneuver lifetime caused by orbit maneuvers needed for stationkeeping are within acceptable limits. Thus, for the 24 h orbit constellation alternatives using two satellites, two versions with an inclination of 75.0° and 90.0° will be studied further together with the critically inclined version. The 24 h constellations with three satellites have good coverage when critically inclined. Thus, they have limited advantage of a higher inclination.

4.2 Eccentricity and satellite handover

The eccentricity is an important orbital parameter for a HEO satellite communications system. As discussed in Chapter 3, high eccentricity is advantageous as it increases the dwell time and improves coverage. However, there are limits on how large the eccentricity can be as illustrated in Figure 3.1. In addition, there are other conditions that influence the choice of eccentricity. This may be considerations such as a desire to avoid the Van Allen radiation belts, reduce the perigee drift or optimizing for satellite handover.

With at least two satellites needed for continuous communications, handover between satellites is a key issue for a HEO satellite system. Seamless handover between satellites with only one terminal antenna would be an attractive feature for many users. That is not possible for all the constellation alternatives that are studied here, but it is possible for some of them. A prerequisite for seamless handover is that the satellites in a constellation have identical ground tracks. However, identical ground tracks does not necessarily imply that the constellation support seamless handover at every handover, or even at all.

For seamless handover to be possible with only one user terminal antenna, the incoming and outgoing satellite must be within the user terminal antenna beam. This is only possible if and when the satellite ground tracks intersect. Such a ground track intersection point can also be referred to as the handover point. A HEO satellite ground track forms a closed loop if the orbits have an appropriate eccentricity. Figure 4.14 illustrates this; exemplified by a 12 h critically inclined orbit with an eccentricity of 0.74. The time a satellite uses inside the ground track loop can be controlled by adjusting the eccentricity.

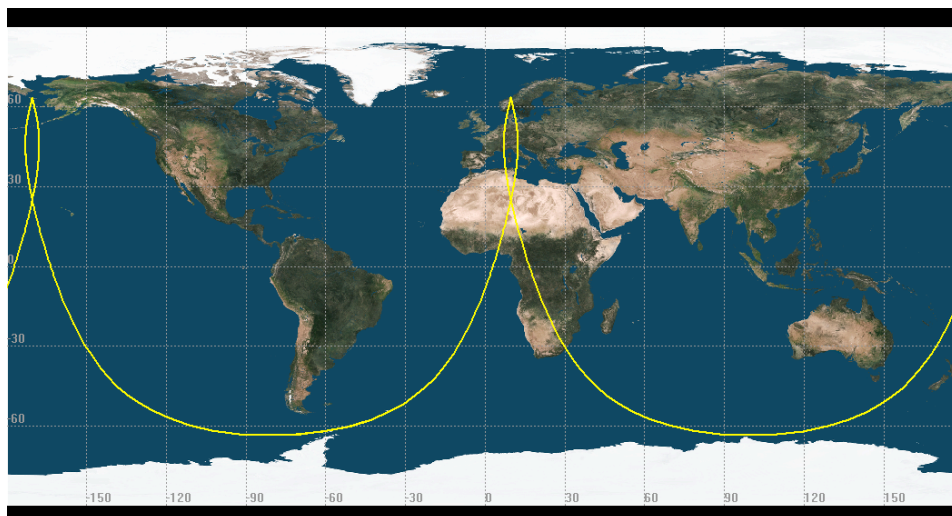

Figure 4.14: A HEO ground track with the characteristic loop. The yellow line shows the ground track of a 12 h critically inclined HEO with an eccentricity of 0.74.

Thus, with the right eccentricity and positioning of satellites in orbit, seamless handover can be realized.

These considerations are all necessary to take into account when finding the optimal eccentricity. The following sections address each constellation alternative and discuss the appropriate eccentricity. For coverage considerations, satellite visibility above 60° northern latitude is used as a target. This corresponds to the extended coverage area which is a larger area than stipulated by the coverage requirement. Both these coverage definitions are discussed in section 2.3. The extended coverage area allows service provision to a larger market and ensures high elevation angles within the required coverage area.

4.2.1 12 hour orbit

The ground track of a critically inclined 12 h HEO satellite will form a closed loop when the eccentricity is higher than 0.7123. For eccentricities from 0.7123 to 0.7366 the ground track intersects twice around apogee. The area around apogee of such ground track is illustrated in Figure 4.15. As the eccentricity increases above 0.7123, the southern intersection point will move south while the northern intersection point moves north. When the eccentricity reaches 0.7366, the northern intersection point disappears.

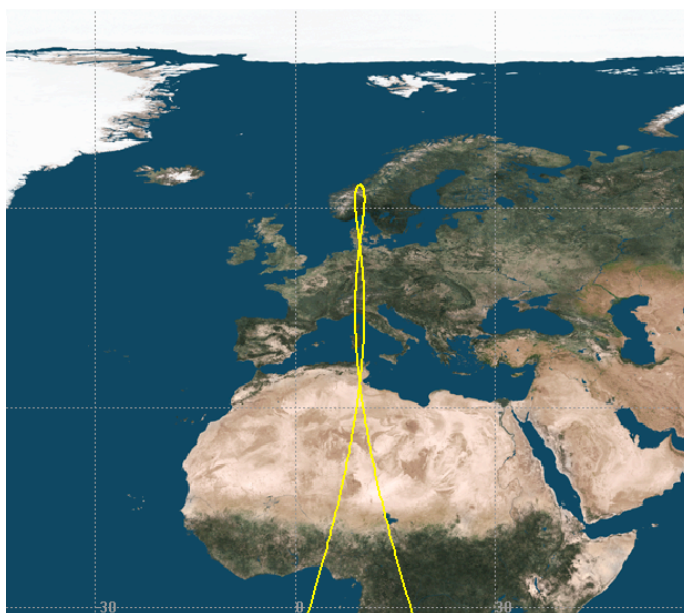

Figure 4.15: The ground track loop of a 12 h HEO with two intersections. The yellow line show the ground track around apogee of a 12 h critically inclined HEO with an eccentricity of 0.72.

With an eccentricity of 0.7123, a satellite will use about 8 h in the loop. As the eccentricity increases, the time a satellite uses in the northern loop will be reduced. In parallel, the time used between each pass of the southern intersection point will increase. An eccentricity of 0.72, as the example illustrated in Figure 4.15, will ensure that a satellite use about 6 h in the northern loop, and about 9 h and 20 min between the first and second pass of the southern intersection point. When the eccentricity is so large that the ground track only has one intersection point, a satellite will spend just over 10 h in the loop.

A constellation of three satellites providing dual coverage requires the satellites to be active for 8 h each orbit. Seamless handover between satellites at the ground track intersection point then result in a loop size of 8 h. For a critically inclined 12 h HEO this is achieved when the eccentricity is 0.7125. A ground track example is shown in Figure 4.16. With two satellites in a 12 h orbit constellation, the satellites must be active for 6 h each orbit. A constellation with two satellites in individual orbital planes allows for seamless handover every other handover. At the other handovers, the satellites will be around different apogee locations. The required loop size of 6 h is achieved with an eccentricity of 0.7195. Thus, it should be used in a 12 h orbit constellation

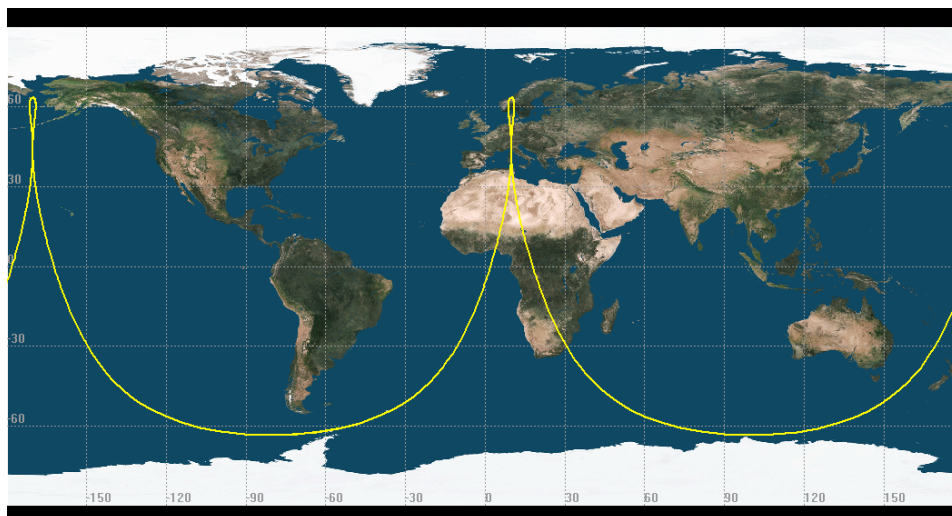

Figure 4.16: Ground track of a 12 h HEO satellite with an eccentricity of 0.7125. The ground track repeat it self after 24 h. A satellite will be in the northern loop for 8 h each orbit.

with two satellites in individual orbital planes. A ground track example for such a satellite is illustrated in Figure 4.17.

A 12 h HEO constellation with two satellites in the same orbital plane is not able support seamless handover. Therefore, other considerations are more important for the selection of eccentricity than the position of the ground track intersection point. A higher eccentricity will increase the potential coverage area, but only marginally. There are also adverse effects of a higher eccentricity. One example is the increased atmospheric drag due to reduced perigee altitude. An eccentricity of 0.7195 is, therefore, deemed appropriate also for the constellation alternative with two satellites in the same orbital plane.

4.2.2 16 hour orbit

Critically inclined 16 h HEO satellites will have a ground track which loops when the eccentricity is higher than 0.3997. A ground track with two loops and two intersection points around each apogee is created when the eccentricity is between 0.3997 and 0.6202. The size and shape of the loops changes with eccentricity in the same manner as for the 12 h orbit.

A satellite in an orbit with eccentricity 0.3997 will spend about 12 h and 30 min

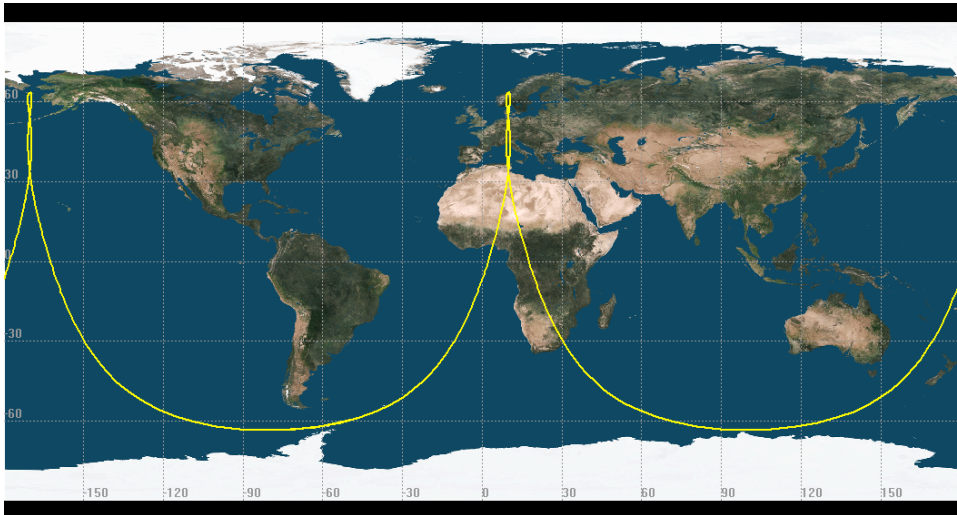

Figure 4.17: Ground track of a 12 h HEO satellite with an eccentricity of 0.7195. The ground track repeat it self after 24 h. A satellite will be in the northern loop for 6 h each orbit.

in the loop. As the eccentricity increases, the time spent in the northern loop is reduced while the time spent in the southern loop increases. The eccentricity needed for visibility above 60° North 50 % of the time, 0.4356, gives a northern loop size of about 10 h and 40 min. When the eccentricity is above 0.6202 and the northern loop has disappeared, a satellite will use more than 15 h between passes of the ground track intersection point.

Two 16 h HEO satellites in individual planes can support seamless handover, but only at every other handover. For continuous coverage, the satellites need to be active for 8 h per orbit. Thus, in order to be able to support seamless handover the ground track loop size must be 8 h. A critically inclined 16 h HEO satellite will spend 8 h in the northern loop when the eccentricity is 0.5255. In a constellation of two satellites in individual planes with RAAN 120° apart, this eccentricity should be used. Figure 4.18 show an example of the ground track of such a constellation.

The ground tracks of two satellites in the same plane and spaced 180° apart will be identical. However, they will never be around the same apogee location at the same time. Thus, seamless handover is never possible. As a result, other considerations should be factored in when choosing the appropriate eccentricity. One such consideration is the radiation environment. A low eccentricity will result in a high perigee altitude which reduce the influence

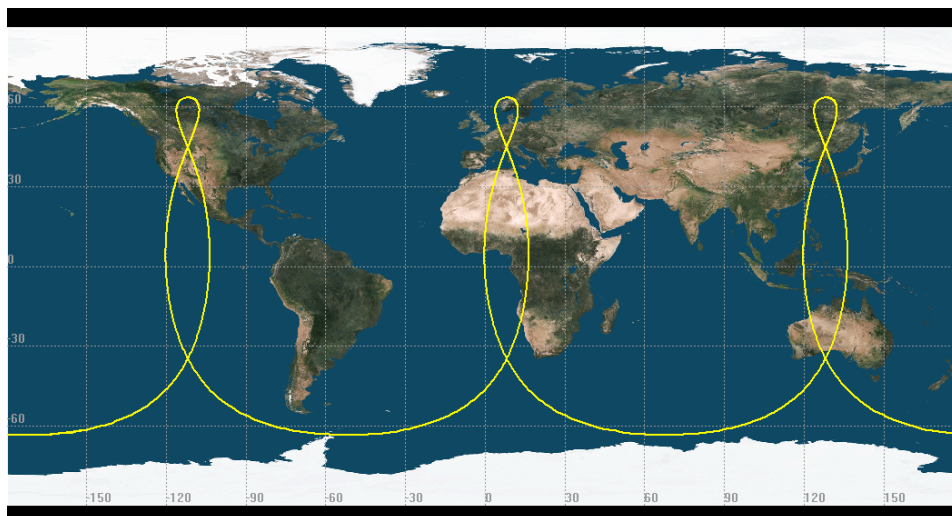

Figure 4.18: Ground track of a 16 h HEO satellite with an eccentricity of 0.5255. The ground track repeat it self after 48 h. A satellite will be in the northern loop for 8 h each orbit.

from the Van Allen radiation belts. Improved radiation environment will give increased satellite reliability and lifetime. A lower eccentricity also makes the orbit less susceptible to perturbations. On the other hand, a higher eccentricity will give increased coverage and availability.

The eccentricity chosen for the individual planes constellation will result in a perigee altitude of almost 9 000 km. That is the outskirts of the inner Van Allen belt, where high energy protons are trapped. The outer Van Allen belt contains high energy electrons that are less harmful and easier to shield against compared to high energy protons. Thus, a 16 h HEO satellite with an eccentricity of 0.5255 should have an acceptable radiation environment. Therefore, with limited coverage improvement from increased eccentricity, it has been found to be appropriate with an eccentricity of 0.5255 also for the single plane 16 h orbit constellation alternative. An example of the ground track of a satellite in such an orbit is shown in Figure 4.18.

4.2.3 18 hour orbit

The ground track of an 18 h critically inclined HEO satellite has loops around the apogee when the eccentricity is above 0.2110. Up to an eccentricity of

0.5669 the ground track has two intersection points per orbit. The loops of the 18 h orbit change with eccentricity similar to the 12 h and 16 h orbits.

With an eccentricity of 0.2110, a satellite will be in the loop for close to 14 h. A higher eccentricity reduces the time spent in the northern loop, and an eccentricity of 0.4258 gives a loop size of 8 h and 37 min. This is the eccentricity needed for satellite visibility 50 % of the time above 60° North. If the eccentricity is larger than 0.5669, the northern loop disappears, and the ground track will only have one loop around apogee. A satellite will spend more than 17 h in that loop each orbit.

For continuous coverage from a constellation of two 18 h HEO satellites, the satellites must be active for 9 h each orbit. A satellite will pass the northern ground track intersection point every 9 h when the orbit has an eccentricity of 0.4100. As mentioned above and in Chapter 3, an eccentricity of at least 0.4258 is necessary for a satellite to be visible above 60° North for more than 50 % of the time. Thus, seamless handover at the ground track intersection point can not be achieved with an 18 h HEO constellation consisting of two satellites.

Since seamless handover is not a possible feature for 18 h HEO constellations, the only advantage individual orbital planes offer is identical ground tracks. With identical ground tracks, the number of apogee locations is reduced from eight to four. This has no influence on the choice of eccentricity. Therefore, it is logical that both 18 h HEO constellation alternatives use the same eccentricity.

As seamless handover is not a factor in choosing the eccentricity, other considerations such as radiation environment, coverage and ground track longitudinal variation become important. Coverage will be adequate as long as the eccentricity is above 0.4258. For the 16 h orbit, it was assumed that a perigee altitude close to 9 000 km provided an acceptable radiation environment. An 18 h orbit with that perigee altitude will have an eccentricity of about 0.5580. Thus, both coverage and radiation environment are adequately addressed as long as the eccentricity is in the range from 0.4258 to 0.5580.

Minimal ground track longitudinal variation during the 9 h a satellite will be active around apogee, is achieved with an eccentricity of 0.4710. This value is a little below the middle of the acceptable range. It should, therefore, be able to provide both good coverage and radiation environment. Hence, an eccentricity of 0.4710 has been chosen for the 18 h HEO constellation alternatives. A ground track example is shown in Figure 4.19.

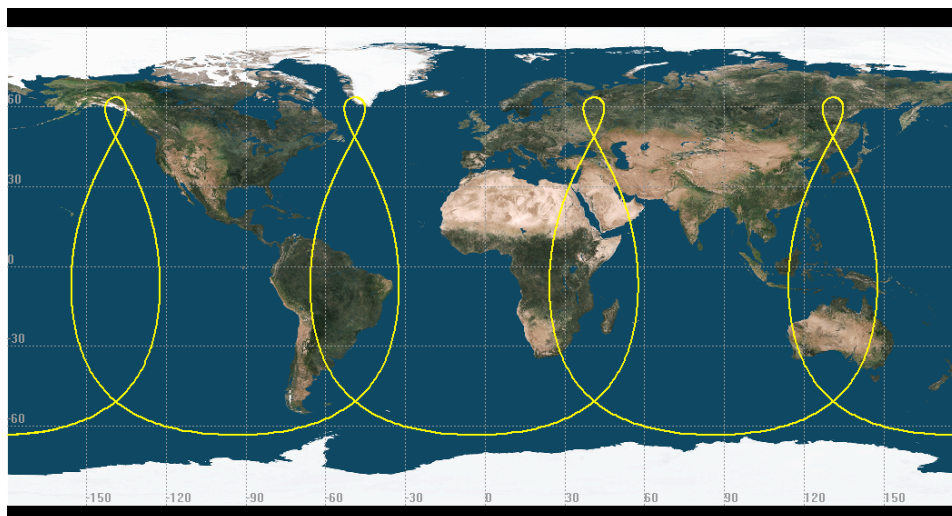

Figure 4.19: Ground track of a 18 h HEO satellite with an eccentricity of 0.4710. The ground track repeat it self after 72 h. A satellite will be above 41° northern latitude for 9 h each orbit.

4.2.4 24 hour orbit

The ground track of a satellite in an inclined 24 h orbit will form a figure eight already when the eccentricity is zero, and the orbit is circular. As the eccentricity is increased, the southern loop gets larger while the northern loop becomes smaller. For critically inclined orbits, the northern loop disappears when the eccentricity is above 0.4225. When the inclination is increased to 75° , the northern loop does not disappear before the eccentricity is above 0.6810. With an inclination of 90° , the ground track will always loop and form a ground track intersection point.

A satellite in a critically inclined 24 h orbit will spend 12 h in the northern loop when the orbit is circular. Increasing eccentricity will reduce the time a satellite spend in the northern loop. Satellite visibility above 60° North for 33.3 % of the time is possible with an eccentricity above 0.1404. At that eccentricity, the satellite will spend slightly more than 10 h in the northern loop. Increasing the eccentricity to 0.4048 reduces the time spent in the northern loop to about 3 h. The eccentricity needed for visibility above 60° North for 50 % of the time is 0.4048.

In a 24 h HEO constellation with two satellites, a satellite must be available for 12 h each orbit. Based on this it can be concluded that seamless handover can

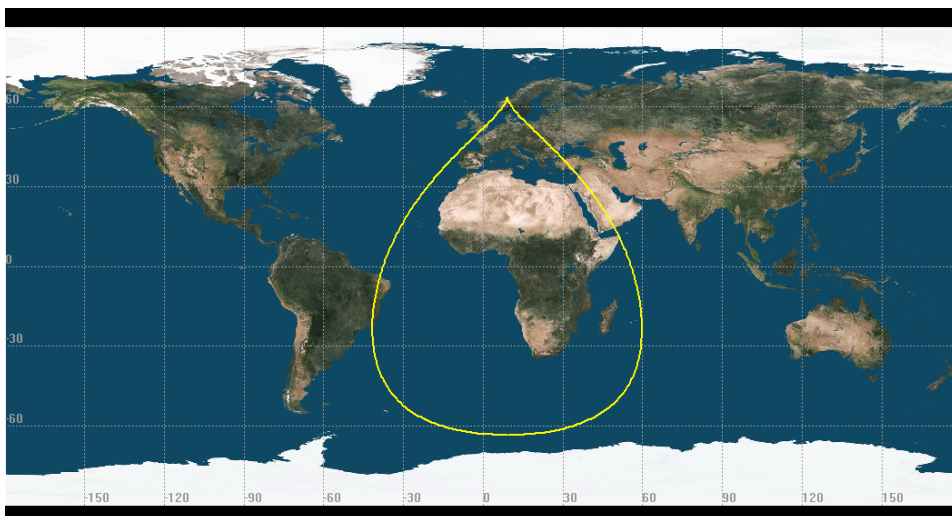

Figure 4.20: Ground track of critically inclined 24 h HEO satellite with an eccentricity of 0.4200. The ground track repeat it self after 24 h. A satellite will be above 38° northern latitude for 12 h each orbit.

not be achieved with two critically inclined satellites. The possible eccentricity range for a constellation with two critically inclined satellites is from 0.4048 to 0.4319. This will give a perigee altitude outside the harshest part of the Van Allen radiation belts. Therefore, coverage is the most important consideration when selecting the eccentricity. An eccentricity of 0.4200 is deemed appropriate both for the single and individual orbital plane alternatives. It should give adequate coverage and not push the limit on apogee altitude. Figure 4.20 illustrates the droplet shaped ground track of a 24 h HEO satellite with that eccentricity.

With three satellites in the constellation a satellite only has to be active for 8 h each orbit. A northern loop size of 8 h is possible for a critically inclined satellite when the eccentricity is 0.2670. Three satellites in individual orbital planes which creates identical ground tracks can then fully support seamless handover around one apogee location. Thus, it is natural to select an eccentricity of 0.2670 for that constellation alternative. Seamless handover is not possible for the constellation alternative with three satellites in the same orbital plane. However, the same eccentricity is deemed appropriate as it provides adequate coverage and has a low apogee altitude. The illustration in Figure 4.21 shows a ground track example for a satellite in such an orbit.

A satellite in a circular 24 h orbit with 75° inclination will use 12 h between

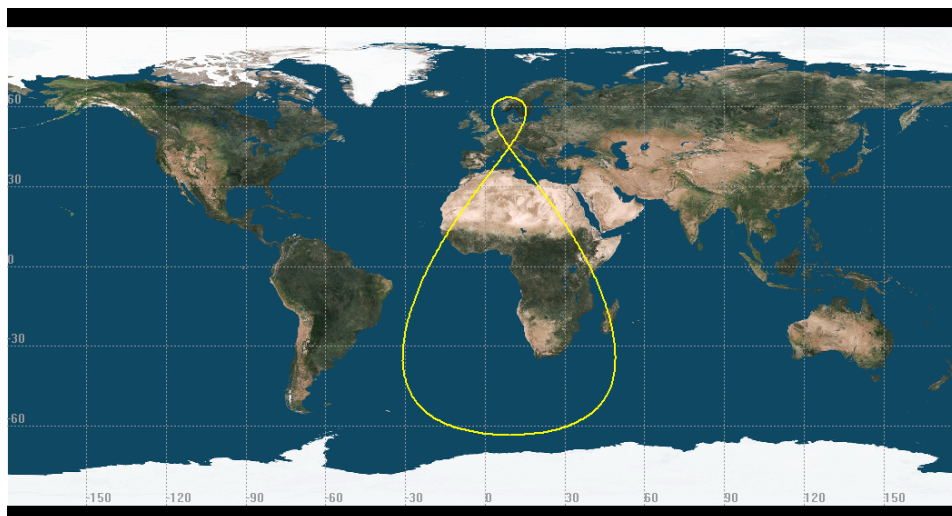

Figure 4.21: Ground track of a critically inclined 24 h HEO satellite with an eccentricity of 0.2670. The ground track repeat it self after 24 h. A satellite will spend 8 h inside the northern loop each orbit.

every pass of the ground track intersection point. As for the critically inclined version, increased eccentricity will reduce the time spent in the northern loop. However, the reduction will be slower, and the coverage with a given eccentricity will be better. An eccentricity of 0.3711 is necessary for satellite visibility above 60° North for 50 % of the time. That corresponds to a northern loop size of about 9 h and 35 min.

From these findings it is evident that seamless handover is not achievable with two satellites in 24 h orbits inclined 75°. The eccentricity must be somewhere between 0.3711 and 0.4319 for the orbit to be acceptable. From the previous discussion on inclination and perigee drift, it is clear that satellite lifetime will benefit from a low eccentricity. However, from Figure 4.13 it can be observed that within the acceptable eccentricity range, the difference in the lifetime is limited to less than 10 %. Minimum ground track longitudinal variation during the active period occur with an eccentricity of 0.4145. This eccentricity seems like a reasonable choice and will be used in both constellation alternatives with 75° inclination. An example of the resulting ground track is illustrated in Figure 4.22.

Satellites in 24 h orbits with an inclination of 90° will always spend an equal amount of time in the northern and southern loop regardless of eccentricity. Thus, with 12 h in the northern loop for all eccentricity values, seamless han-

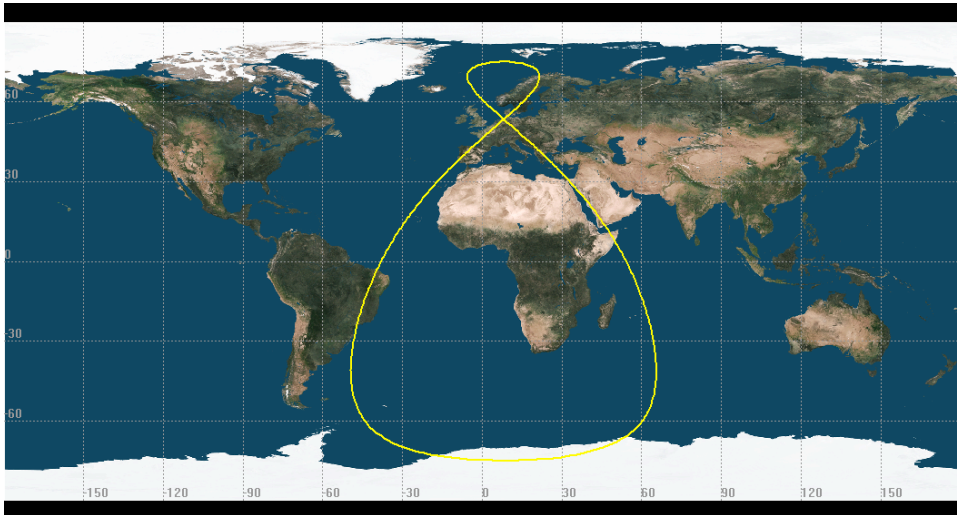

Figure 4.22: Ground track of a 24 h HEO satellite inclined 75° with an eccentricity of 0.4145. The ground track repeat it self after 24 h. A satellite will be above 41° northern latitude for 12 h each orbit.

doover can be realized with two satellites in individual orbital planes that have a RAAN 180° apart. Satellite visibility for more than 50 % of the time above 60° North is possible with an eccentricity larger than 0.3548. Therefore, an eccentricity of 0.3600 should provide adequate coverage while at the same time keeping the reduction in satellite lifetime at a minimum. This eccentricity will be used in the 24 h orbit constellation with an inclination of 90° and two satellites in individual orbital planes. The ground track of such an orbit is illustrated in Figure 4.23.

The constellation alternative using two satellites in the same orbital plane inclined 90° does not support seamless handover. With the two satellites phased 180° in the orbital plane, full coverage can be achieved even if the eccentricity is lower than 0.3548. The constellation alternatives supporting seamless handover will move all traffic to the incoming satellite at the same time, when both satellites are above the ground track intersection point. When seamless handover is not an option, traffic can be handed over as soon as the incoming satellite provides a better geometry. Thus, each satellite does not need to be available in the whole coverage area 50 % of the time. It is enough that one of the satellites is available at any given time.

This freedom allows the eccentricity to be reduced for the single plane alternative, and still provides adequate coverage. Lowering the eccentricity is

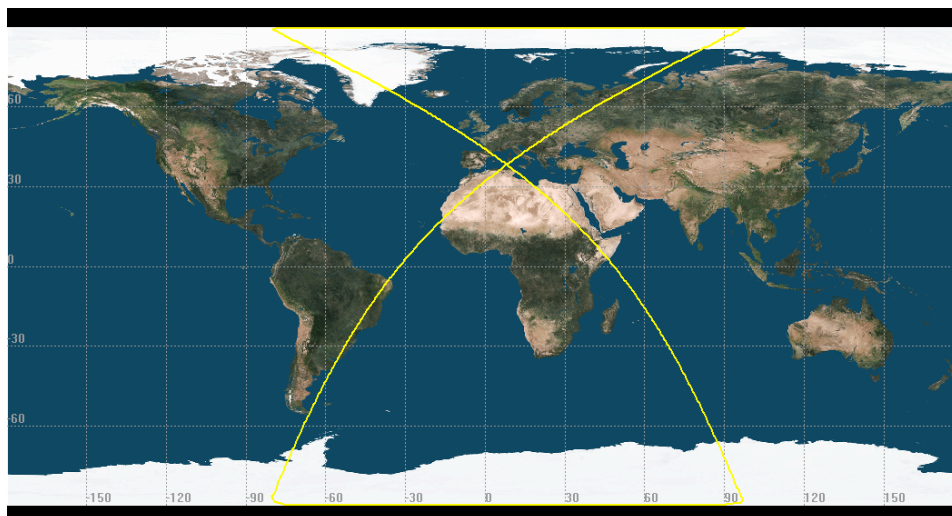

Figure 4.23: Ground track of a 24 h HEO satellite inclined 90° with an eccentricity of 0.3600. The ground track repeat it self after 24 h. A satellite will pass the ground track intersection point every 12 h.

beneficial as it reduces the perigee drift and the effect it has on satellite lifetime. Visibility to at least one satellite at all times above 60° North is achieved with an eccentricity of only 0.0874. Thus, for the constellation alternative using two satellites in 24 h orbits inclined 90° an eccentricity of 0.1000 has been selected. It should provide adequate coverage while keeping the eccentricity low enough for the perigee drift to have an acceptable impact on satellite lifetime. The ground track of a satellite in such an orbit will be similar to the one shown in Figure 4.23, but with less curving and a more southerly ground track intersection point.

4.3 Constellation alternatives

Based on the findings in Chapter 3, and the discussion above, there are fifteen constellation alternatives that warrant further consideration. These fifteen constellations are listed in Table 4.1 along with relevant orbital parameters and constellation information. There are three alternatives using 12 h orbits, two each using 16 h and 18 h orbits and eight using 24 h orbits. All the 12 h, 16 h and 18 h orbit alternatives use the critical inclination of 63.435° . This is also the case for four of the 24 h orbit alternatives. The remaining four

constellation alternatives are divided in two groups with the satellites inclined 75° and 90° .

The constellations have been given names according to the following notation:

- The first number denotes the approximate orbital period, indicated by the H , which is short for hours.
- The second number tells how many satellites there are in the constellation. That is indicated by the S , which is short for satellites.
- The third number denotes how many orbital planes the constellation has, as indicated by the P , which is short for planes.
- Four of the constellations also have a fourth number. This indicates the inclination of the orbital planes. The constellations without the fourth number are critically inclined.

In Table 4.1, it can be observed that the apogee altitude in the various alternatives ranges from 39 109 km to 53 495 km. Thus, the highest apogee altitude is about 37 % higher than the lowest apogee altitude. It should also be noted that the satellite orbits in constellation alternative 24H2S1P90 have such a low eccentricity that it might not be correct to call it a HEO. Nevertheless, that constellation alternative has some attractive properties, and an assessment along with the other alternatives will provide valuable understanding and knowledge.

The fifteen constellation alternatives are all distinct in various aspects. They all have different advantages and disadvantages. In Chapter 5, a range of properties is evaluated and discussed with the objective of identifying the best constellation alternative for support of communications in the Arctic.

Table 4.1: Summary of orbital parameters for the constellations assessed for Arctic coverage.

Name	Period [h]	Satellites [#]	Planes [#]	Inclination [°]	Eccentricity	Apogee altitude [km]	Perigee altitude [km]
12H2S1P	11.962	2	1	63.435	0.7195	39295	1072
12H2S2P	11.962	2	2	63.435	0.7195	39295	1072
12H3S3P	11.962	3	3	63.435	0.7125	39109	1258
16H2S1P	15.956	2	1	63.435	0.5255	42708	8890
16H2S2P	15.956	2	2	63.435	0.5255	42708	8890
18H2S1P	17.951	2	1	63.435	0.4710	44821	12034
18H2S2P	17.951	2	2	63.435	0.4710	44821	12034
24H2S1P	23.934	2	1	63.435	0.4200	53495	18077
24H2S2P	23.934	2	2	63.435	0.4200	53495	18077
24H3S1P	23.934	3	1	63.435	0.2670	47044	24528
24H3S3P	23.934	3	3	63.435	0.2670	47044	24528
24H2S1P75	23.934	2	1	75.000	0.4145	53263	18309
24H2S2P75	23.934	2	2	75.000	0.4145	53263	18309
24H2S1P90	23.934	2	1	90.000	0.1000	40003	31570
24H2S2P90	23.934	2	2	90.000	0.3600	50965	20607

Chapter 5

Constellation assessment and selection

A HEO based satellite system providing communications to the Arctic requires a constellation of satellites for continuous coverage. The process of identifying the best performing constellation alternative is not straight forward, and there are many factors to consider. The most important include coverage, availability, satellite handover and radiation exposure. One constellation alternative will not be able to outperform all others across the board. Thus, careful trade-offs are required when selecting a constellation.

In the following sections, properties that are important when designing and investing in a satellite communications system is evaluated and discussed. The evaluation process has addressed eight key properties, and looked at how the fifteen constellation alternatives identified in the previous chapter perform. Based on the results from this evaluation, the constellations are weighted against each other.

5.1 Evaluation of alternatives

In order to identify the constellation that can combine coverage and performance in the most cost efficient way, a range of properties must be evaluated and assessed. The importance and impact of the different properties can then be traded off against each other, allowing the best solution to be selected. In the following sections, eight different key properties of the constellation

alternatives will be addressed and discussed:

- Radiation exposure
- Launch cost
- Coverage
- Elevation angle
- Azimuth angle
- Frequency coordination
- Stationkeeping
- Initial operational phase

The eight properties can be loosely grouped into a few categories. Radiation exposure and stationkeeping requirements have an impact on satellite lifetime which is of paramount importance for the system cost. Another property with an impact on system costs is the cost of launching the satellites into their orbit. Coverage, elevation angle and azimuth angle are three properties that provide valuable information about system availability and reliability. An important period for a system with multiple satellites is the initial operational phase. The length of this phase and functionality during that period has an impact on the business case of a satellite system. How the various constellation alternatives can be expected to influence frequency coordination of the satellite system, is also discussed and evaluated. Additionally, free space loss and signal delay are given brief consideration. They affect the radio signal, but are not regarded as key properties.

Satellite constellations for Arctic communications have also been assessed in two papers presented at two conferences. One paper assessed constellation alternatives slightly different from those evaluated here, and focused on communications specific performance [13]. The other paper investigated the same constellation alternatives as those used here, but included free space loss and signal delay as key properties [14].

How the constellation alternatives perform, have been evaluated and assessed on a scale from 1 to 4. On this scale, 4 is equivalent to unacceptable or inadequate. A grade of 3 equals acceptable or adequate, but nothing more. The grades 2 and 1 are used when the performance of a constellation alternative is good and very good. Results from the evaluation of the eight key properties are summarized in Table 5.9.

5.1.1 Free space loss and signal delay

Compared to a GEO satellite reference, the worst case free space loss experienced with the constellation alternatives will be 0 dB to 3 dB higher. For the constellation alternatives, an increased orbital period normally results in an increased free space loss. Higher free space loss can be compensated, both on the satellite side and on the earth station side. Examples are the use of spot beams and higher power onboard the satellites and larger antennas and transmit power at the earth stations. Such countermeasures may increase the system cost and must be traded-off against other system properties. A low free space loss is an advantage, but all the constellation alternatives are within the bounds of what has been deemed acceptable. Therefore, free space loss differences are given limited weight in this evaluation.

Signal delay is not a crucial issue which has a large impact on the selection of satellite constellation. For several applications such as broadcasting and file transfer, the signal delay is irrelevant. Real time applications and services where signal delay is a problem can usually be adapted to handle it. Users of voice services will after a short time get used to it, and protocol issues can be handled by extra equipment mimicking the expected behavior. A short signal delay is preferable, but most services and applications can function at an acceptable level even with a large signal delay. For the constellation alternatives evaluated here, the round trip signal delay is between 0 % and 35 % higher than for a GEO satellite reference. The limited difference has been deemed insignificant for the constellation selection process.

5.1.2 Radiation exposure

In space high energy electrons and ions, mostly protons, are part of an inhospitable environment. This radiation will over time degrade satellite components such as solar panels and electronics. Single events such as bit flips and latch-ups can also be caused by radiation exposure. Thus, the radiation a satellite is exposed to impact both the long term satellite lifetime and the short term availability and reliability. A low impact from radiation exposure on satellite lifetime is desirable. This can be achieved in two ways. One of them is to use a satellite orbit that offers a low-radiation environment. The other possibility is to shield the satellite and important components against radiation which reduces the degradation effects. Both alternatives have an impact on the overall system design.

Around the earth, high energy electrons and protons are trapped in the earth's magnetic field. This radiation is mostly confined inside two toroidal regions centered around the magnetic equator. These two toroidal regions are called the Van Allen radiation belts. The inner belt contains predominantly high energy protons and stretches from about 1 000 km to 10 000 km above the earth. At an altitude from about 20 000 km to 33 500 km, the outer Van Allen belt mostly contains less problematic high energy electrons [17].

Compared to high energy protons, high energy electrons are less harmful, and it is easier to shield against their effects. Coupled with the high inclination used in all the constellation alternatives it is assumed that the effects of the inner Van Allen belt will cause the most harm. Based on this it is evaluated that orbits that stay outside of both Van Allen belts have a very good radiation environment. Furthermore, satellites with orbits that only passes through the outer Van Allen are assumed to be in a good radiation environment. Satellites that pass through both Van Allen belts will experience the worst radiation environment. However, it is believed that, through the use of appropriate shielding and careful selection of materials and components, the radiation environment will be acceptable.

The Van Allen belts shroud the earth around the equator. Thus, to see if an orbit passes through the belts the satellite altitude above equator has been established. That has been done through calculation of the semi-latus rectum, p , for the various orbits using the following expression:

$$p = a(1 - e^2) \quad (5.1)$$

where a is the semimajor axis and e is the eccentricity [11]. The altitude above the equator is found by subtracting the earth's radius from p . These values are shown in Table 5.1 for all the constellation alternatives. The equator altitude indicates how affected the various constellation alternatives interact with the Van Allen belts.

Since the radiation environment has an impact on satellite lifetime, it is an important parameter to consider when selecting a HEO constellation for Arctic communications. However, it is assumed that all the fifteen constellation alternatives have an acceptable radiation environment. There will be differences in satellite lifetime between the constellations, but these differences can be limited. With the use of appropriate shielding and modern technology, the lifetime of satellites in, for example, 12 h orbits can be extended towards that of 24 h orbits. One example of such modern technology is electronic devices based on gallium arsenide as they appear to be unusually immune to total dose radiation effects [17].

Table 5.1: Evaluation of the radiation environment for the fifteen constellation alternatives. The key evaluation criteria is the equator altitude of the orbits. Orbits with an equator altitude under 10 000 km pass through both of the Van Allen radiation belts. Satellites in an orbit with equator altitude above 30 000 km will not be significantly affected by the Van Allen radiation belts.

Name	Perigee altitude [km]	Equator altitude [km]	Grade
12H2S1P	1 072	6 438	3
12H2S2P	1 072	6 438	3
12H3S3P	1 258	6 705	3
16H2S1P	8 890	16 919	2
16H2S2P	8 890	16 919	2
18H2S1P	12 034	20 711	2
18H2S2P	12 034	20 711	2
24H2S1P	18 077	28 353	2
24H2S2P	18 077	28 353	2
24H3S1P	24 528	32 785	1
24H3S3P	24 528	32 785	1
24H2S1P75	18 309	28 547	2
24H2S2P75	18 309	28 547	2
24H2S1P90	31 570	35 370	1
24H2S2P90	20 607	30 327	1

5.1.3 Launch cost factor

One of the most obvious cost components of a satellite system is the launch cost. Therefore, low launch costs will directly reduce the total system cost. However, the cost of launching a satellite system is very difficult to estimate without knowledge about satellite dimensions, volume and mass. There exists a number of launch providers that offer a range of launchers with various capacities and in different price ranges. Here, the evaluation of launch cost for the different constellation alternatives is limited to some general considerations on the energy required to put the satellites into orbit. The possibility of putting the satellites in a constellation into orbit with a single launch is also taken into account in the evaluation. Based on this and in comparison with a GEO reference the launch cost of the fifteen constellation alternatives have been assessed.

The additional velocity, ΔV , required to put the satellites into their orbit have been simulated in STK. The results are shown in Table 5.2. A launch from

Cape Canaveral is basis for the simulations. In the simulations, the satellites are launched into a Low Earth Orbit (LEO) with an inclination equal to the inclination of the final orbit. The launcher leaves the satellites in the LEO after providing them with an additional velocity, ΔV_{Launch} . For almost all of the constellation alternatives ΔV_{Launch} is 7.6 km/s. The two constellation alternatives using orbits with an inclination of 90° are exceptions. They are not able to take advantage of the velocity provided by the rotating earth, and need a slightly higher ΔV_{Launch} of 7.8 km/s.

After the satellite has entered the initial LEO, the apogee is raised to the desired altitude. This maneuver requires an additional velocity, ΔV_1 , in the vicinity of 2.5 km/s to 2.6 km/s. When the satellite reaches the apogee, the perigee altitude is raised by adding an additional velocity, ΔV_2 . These two values are listed in Table 5.2 along with their sum for all the fifteen constellation alternatives. Reference values for GEO is also given. Note that the ΔV_2 value for GEO includes the component required to change the inclination from the initial 28.5° to 0°.

In all the constellation alternatives, a single satellite requires less energy to reach orbit than a GEO satellite. The alternatives with a ΔV_{Launch} of 7.6 km/s range from 61 % to 88 % of the energy necessary for GEO insertion. In the case of the two alternatives with 90° inclination that figure is 92 % and 85 %, but that does not take into account the larger ΔV_{Launch} required.

However, as all the constellation alternatives discussed here consist of more than one satellite, how a single satellite compare to GEO is not a good evaluation criteria. The constellation alternatives use two or three satellites placed in one, two or three orbital planes. Constellations with satellites in a single plane can be launched by a single rocket while constellations with multiple orbital planes require multiple launches. To help evaluate the constellation alternatives the Launch Cost Value (LCV) has been defined as

$$LCV = \Delta V_{total} \cdot S + \Delta V_{Launch} \cdot P \quad (5.2)$$

where S is the number of satellites in a constellation and P is the number of orbital planes. The resulting LCV for all the fifteen constellation alternatives and a GEO reference are listed in Table 5.2.

The LCV of the constellation alternatives can be compared to the LCV of the GEO reference. By taking the ratio between a HEO constellation's LCV and the GEO LCV, the Launch Cost Factor (LCF) is found.

$$LCF = \frac{LCV}{LCV_{GEO}} \quad (5.3)$$

Table 5.2: Evaluation of the launch cost for the fifteen constellation alternatives. The rating of the constellation alternatives is based on the Launch Cost Factor (LCF). ΔV_{Launch} is the velocity added by the launcher that bring a satellite into a LEO. ΔV_1 is the additional velocity required to raise the apogee to the correct altitude. ΔV_2 is the additional velocity required to raise the perigee to the correct altitude. The Launch Cost Value (LCV) depend on the number of satellites and orbital planes as well as the ΔV of a constellation alternative.

Name	ΔV_{Launch} [km/s]	ΔV_1 [km/s]	ΔV_2 [km/s]	ΔV_{total} [km/s]	$\Delta V_{ref.GEO}$ [%]	Satellites [#]	Planes [#]	LCV	LCF	Grade
12H2S1P	7.60	2.4784	0.0480	2.5264	61	2	1	12.6528	1.08	1
12H2S2P	7.60	2.4784	0.0480	2.5264	61	2	2	20.2528	1.73	2
12H3S3P	7.60	2.4757	0.0649	2.5406	62	3	3	30.4218	2.60	3
16H2S1P	7.60	2.5245	0.5453	3.0698	75	2	1	13.7396	1.17	1
16H2S2P	7.60	2.5245	0.5453	3.0698	75	2	2	21.3396	1.82	2
18H2S1P	7.60	2.5502	0.6668	3.2170	78	2	1	14.0340	1.20	1
18H2S2P	7.60	2.5502	0.6668	3.2170	78	2	2	21.6340	1.85	2
24H2S1P	7.60	2.6383	0.7896	3.4279	83	2	1	14.4558	1.23	1
24H2S2P	7.60	2.6383	0.7896	3.4279	83	2	2	22.0558	1.88	2
24H3S1P	7.60	2.5753	1.0295	3.6048	88	3	1	18.4144	1.57	2
24H3S3P	7.60	2.5753	1.0295	3.6048	88	3	3	33.6144	2.87	3
24H2S1P75	7.60	2.6397	0.8221	3.4618	84	2	1	14.5236	1.24	1
24H2S2P75	7.60	2.6397	0.8221	3.4618	84	2	2	22.1236	1.89	2
24H2S1P90	7.80	2.4889	1.2931	3.7820	92	2	1	15.3640	1.31	2
24H2S2P90	7.80	2.6152	0.8905	3.5057	85	2	2	22.6114	1.93	2
GEO	7.60	2.3469	1.7680	4.1149	-	1	1	11.7149	-	-

The LCF is assumed to be a good evaluation and assessment criteria for constellation launch cost, and the results of the fifteen constellation alternatives are provided in Table 5.2.

All the constellations are deemed to have acceptable launch costs, but there are large differences in LCF between the constellation alternatives. While the 12H2S1P constellation has a LCF just barely higher than a single GEO satellite, the LCF of 24H3S3P is close to three times as high as a single GEO satellite. The launch cost has a large impact on the total system cost. Thus, a high launch cost will be a show stopper for a constellation alternative unless there are other great advantages with the alternative that can justify the high launch cost.

5.1.4 Coverage

A satellite constellation's ability to provide coverage to the area of interest is essential for its success. In Chapter 2.3, the coverage requirement for a satellite system providing communications to the Arctic was defined as the area above 70° northern latitude. Thus, this is the minimum coverage the constellation alternatives should be able to support, but an ability to provide services in an even larger coverage area can be an advantage. That will increase the potential market and strengthen the business case of the satellite system. Arctic communications demands are seasonal with considerable variation between summer and winter. A larger coverage area will allow capacity to be used further south in periods with reduced traffic in the high North. Around 60° northern latitude is assumed to be an appropriate limit for extended coverage.

The coverage of the fifteen constellation alternatives has been simulated in STK. For continuous coverage, it is necessary with visibility to at least one satellite at all times. Simulations were performed to identify how the constellation alternatives meet this requirement. Figure 5.1 shows the percentage of time at least one satellite is visible as a function of latitude. Based on these results it is evident that all the fifteen constellation alternatives will be able to provide continuous coverage of the area above 60° North. This is as expected since coverage above 60° northern latitude was a design criteria as discussed in Chapter 4. The strange dip in the coverage percent of 24H3S1P is caused by a combination of the longitudinal spacing of the ground tracks and the significant time the satellites spend above the southern hemisphere.

As the constellation alternatives consist of two or three satellites, there is a possibility they all have the capability to provide dual coverage. Dual coverage

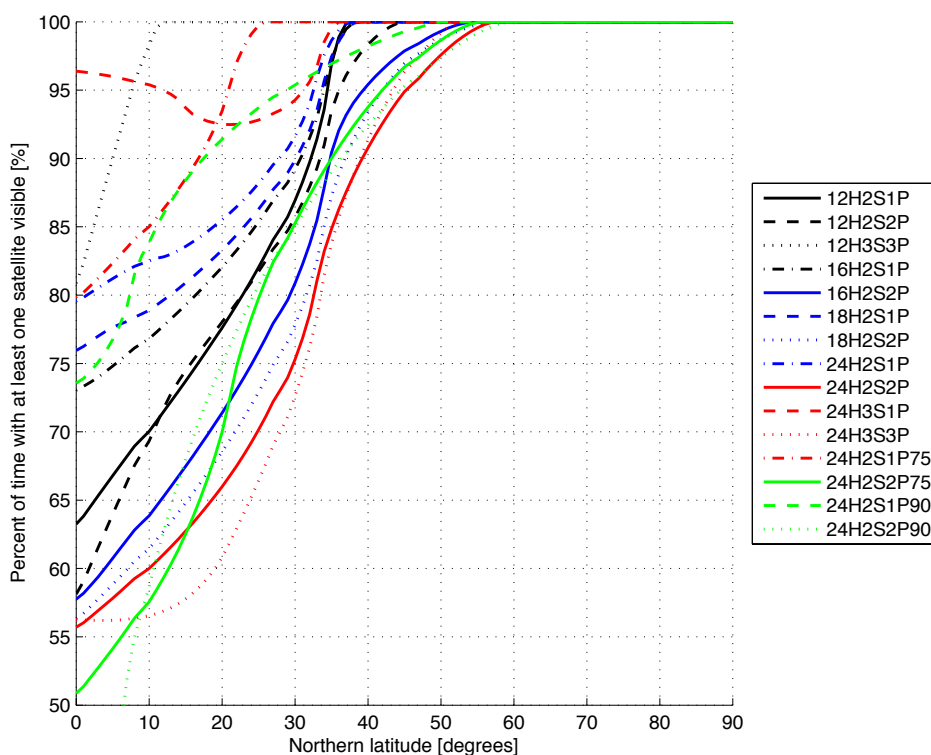

Figure 5.1: Coverage as a function of latitude for the fifteen constellation alternatives. The plots show the percentage of time at least one satellite is visible at a given latitude.

allow for hot redundancy and load sharing between the satellites, which is a great advantage. The extent of visibility towards two satellites at the same time varies between the constellation alternatives. Through simulations, the results shown in Figure 5.2 were found. The figure show the percentage of time at least two satellites are visible as a function of latitude. Only one constellation provides dual coverage continuously. That is 12H3S3P, which has two satellites visible above 58° North at all times. 24H2S1P90 is the worst constellation alternative which only supports dual coverage 2% to 3% of the time. The rest of the constellation alternatives provides dual coverage in a range from about 35% to 85% of the time. It should be noted that in terms of dual coverage above 70° northern latitude, constellations with the same orbital period and number of satellites have the same performance, regardless of single or individual orbital plane configuration.

Based on the simulation results the coverage performance of the fifteen con-

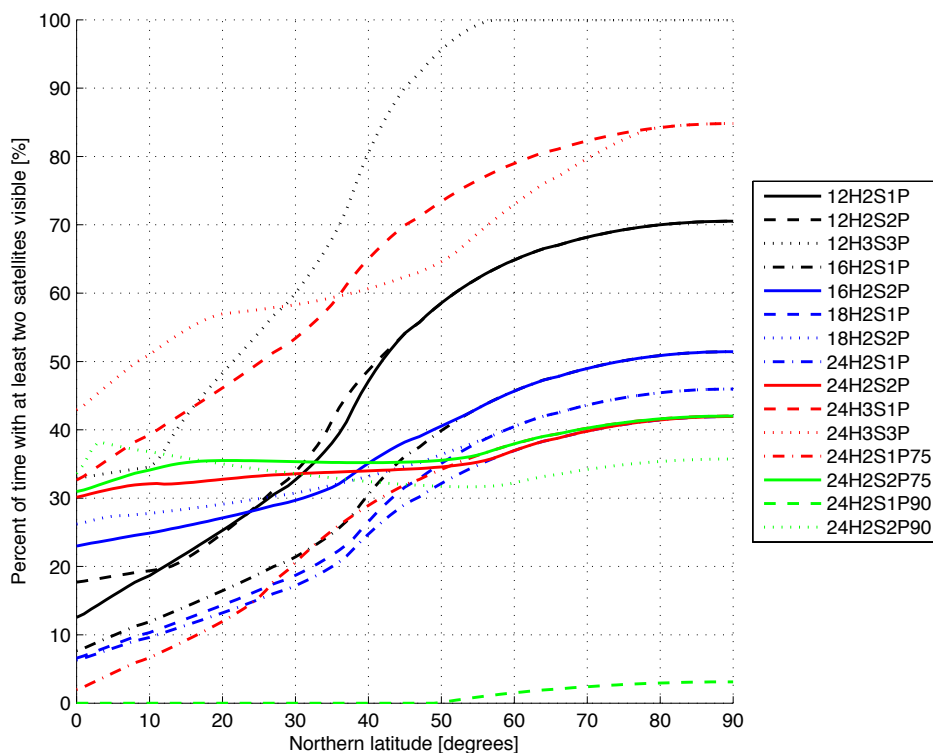

Figure 5.2: Dual coverage as a function of latitude for the fifteen constellation alternatives. The plots show the percentage of time at least two satellites are visible at a given latitude.

stellation alternatives has been evaluated. The simulation results are summarized in Table 5.3. In Chapter 2.3, the coverage requirement was defined to be the area above 70° northern latitude. Therefore, a constellation that support continuous coverage of this area, should have an acceptable coverage performance. The column labeled $\phi_{100\%}$ in Table 5.3 show the lowest latitude at which at least one satellite is visible at all times. From that it can be concluded that all the constellation alternatives meet this minimum requirement. The extended coverage area down to 60° northern latitude can also be covered by all the fifteen constellation alternatives. Again, only one constellation, 12H3S3P, supports continuous dual coverage.

The extent of coverage to the South for any given constellation, is not very significant as long as services can be provided in the extended coverage area. A coverage limit just outside of the coverage area may indicate that users will experience low elevation angles, but that issue will be addressed in the next

Table 5.3: Evaluation of the coverage provided by the fifteen constellation alternatives. $\phi_{100\%}$ is the lowest latitude at which at least one satellite is visible at all times. C_{70N} is the dual coverage time percent at 70° northern latitude.

Name	$\phi_{100\%}$ [°]	C_{70N} [%]	Grade
12H2S1P	38	68.2	2
12H2S2P	45	68.2	2
12H3S3P	13	100.0	1
16H2S1P	39	49.0	2
16H2S2P	55	49.0	2
18H2S1P	39	43.6	2
18H2S2P	58	43.6	2
24H2S1P	38	39.8	2
24H2S2P	58	39.8	2
24H3S1P	37	82.3	2
24H3S3P	53	79.7	2
24H2S1P75	27	40.2	2
24H2S2P75	56	40.2	2
24H2S1P90	50	2.4	2
24H2S2P90	60	34.2	2

section. The only constellation alternative that distinguish itself from the rest is 12H3S3P with its ability to provide continuous dual coverage. Redundancy and load sharing between the active satellites paves the way for smaller and more cost efficient satellites. Thus, this is a valuable and important feature for the 12H3S3P constellation alternative.

5.1.5 Elevation angle

The earth station elevation angle is important in satellite communications. At low elevation angles, the path through the atmosphere gets longer, and the attenuation increases [18]. As a result, a satellite can be useless for communications purposes even if it is visible above the horizon. Use of GEO satellites for communications at high latitudes can exemplify this. A GEO satellite is visible up to about 81° North, but maritime satellite communications users experience unstable service already at 72° to 75° North [6]. Knowledge of the elevation angle is, therefore, important in order to evaluate if a reliable service can be provided by the different constellation alternatives.

Since the satellites in a HEO constellation are not stationary, the elevation angle experienced from a ground station will not be constant. A satellite will come over the horizon and continue up until it reaches apogee. The elevation angle will then decrease again until it disappears under the horizon. For an optimal system performance, the handover between satellites should occur before the elevation angle gets too low. Exactly when the elevation angle is too low depends on both the satellite and ground terminal design. However, based on experience with GEO systems, for a typical maritime user, the elevation angle limit is somewhere between 5° and 10° .

The elevation angles provided by the fifteen constellation alternatives have been simulated in program STK. For the purpose of elevation angle performance evaluation, the worst case position is assumed to be the position within the extended coverage area that will experience the lowest elevation angle. The exact worst case position differs between the various constellation alternatives. It depends on the location of the apogees, number of apogee locations and ground track shape. However, for all the constellation alternatives the worst case position in terms of elevation angle is at 60° North. Table 5.4 shows the simulation results that are key to the elevation angle performance evaluation.

Minimum elevation angle, ϵ_{min} , experienced from the worst case position ranges from 0.6° for 24H2S2P90 to 26.4° for 12H3S3P. The elevation angle performance could be evaluated solely on the basis of ϵ_{min} , but there are other factors that should be taken into account. One of them is the mean elevation angle, ϵ_{mean} . In Table 5.4, it can be observed that a high ϵ_{min} does not necessarily correspond to a high ϵ_{mean} . Figure 5.3 show a plot of the elevation angle observed from the worst case position for 12H3S3P over a 24 h period. The elevation angle has an 8 h recurring pattern with a variation of less than 20° . With the 12H3S3P constellation, any other position inside the extended coverage area will experience better elevation angles at all times.

Some of the other constellation alternatives have very different elevation angle performance. 18H2S2P illustrates this well, and a plot of the elevation angle observed from the worst case position over a period of 72 h is shown in Figure 5.4. Note how the elevation angle varies from 2.9° to 87.9° . The high maximum elevation angle lead to a ϵ_{mean} of 47.1° , even though ϵ_{min} is very low. Over a period of 72 h, before the ground tracks repeats themselves, the elevation angle will be below 10° for approximately 87 min. This corresponds to a daily average of 29 min. Thus, even though ϵ_{min} is very low for 18H2S2P, it can still provide an acceptable service since the elevation is low only for a

Table 5.4: Evaluation of the elevation angle provided by the fifteen constellation alternatives. The results are simulations based on the worst case position in terms of minimum elevation angle, ϵ_{min} , above 60° North. ϵ_{mean} is the mean elevation angle at that worst case position during one ground track repetition. $\delta\epsilon/\delta t_{max}$ and $\delta\epsilon/\delta t_{mean}$ is the rate of change in elevation angle, respectively the maximum and average rate. $t_{\epsilon < 10^\circ}$ is the average daily time the elevation angle is below 10° .

Name	ϵ_{min} [°]	ϵ_{mean} [°]	$\delta\epsilon/\delta t_{max}$ [°/min]	$\delta\epsilon/\delta t_{mean}$ [°/min]	$t_{\epsilon < 10^\circ}$ [min/d]	Grade
12H2S1P	21.1	50.0	0.68	0.07	0	1
12H2S2P	15.3	63.0	1.32	0.12	0	2
12H3S3P	26.4	40.0	0.25	0.08	0	1
16H2S1P	17.0	52.9	0.54	0.12	0	2
16H2S2P	5.8	44.9	0.38	0.07	25	3
18H2S1P	15.7	47.9	0.43	0.10	0	2
18H2S2P	2.9	47.1	0.37	0.08	29	3
24H2S1P	15.1	39.9	0.19	0.06	0	2
24H2S2P	2.3	19.0	0.13	0.07	258	4
24H3S1P	18.7	54.8	0.63	0.10	0	2
24H3S3P	7.6	20.3	0.56	0.08	108	4
24H2S1P75	22.1	45.0	0.22	0.07	0	1
24H2S2P75	4.4	26.9	0.15	0.10	146	4
24H2S1P90	1.2	40.9	0.48	0.18	126	4
24H2S2P90	0.6	33.5	0.20	0.16	192	4

short time and ϵ_{mean} is fairly high. Other positions inside the extended coverage area will experience a higher ϵ_{min} , but the maximum elevation will be lower than for the worst case position.

Another element to consider in the evaluation of the elevation angle performance of the constellation alternatives is the rate of change. A high rate of elevation angle change can potentially increase the ground station tracking requirements. More advanced user terminal solutions will then be needed. In Table 5.4 the maximum rate of change in elevation angle, $\delta\epsilon/\delta t_{max}$, and the average rate of change in elevation angle, $\delta\epsilon/\delta t_{mean}$, is listed for the fifteen constellation alternatives. 12H2S2P has the highest $\delta\epsilon/\delta t_{max}$ at $1.32^\circ/\text{min}$, while the rest of the constellation alternatives has a $\delta\epsilon/\delta t_{max}$ well below $1^\circ/\text{min}$. $\delta\epsilon/\delta t_{mean}$ is in the range from $0.07^\circ/\text{min}$ to $0.18^\circ/\text{min}$ for all the constellation alternatives. These rate of change values are for all fifteen constellation alternatives so low that they do not add complexity to the antenna tracking system on user terminals.

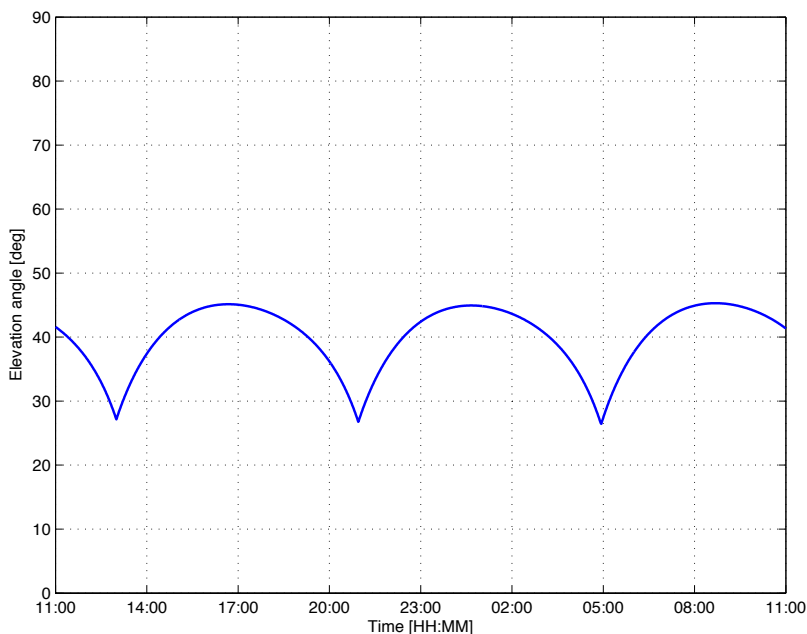

Figure 5.3: Plot of the elevation angle observed from the worst case position over a 24 h period for 12H3S3P. ϵ_{min} is relative high, but the limited elevation angle range result in a moderate ϵ_{mean} .

Based on the simulation results shown in Table 5.4 the constellation alternatives have been evaluated. Constellation alternatives with ϵ_{min} higher than 20° have been rated to have a very good elevation angle performance. A ϵ_{min} above 10° is assumed to provide a good elevation angle performance. As discussed above and previously, experience from GEO systems indicate that an elevation angle above 5° to 10° is necessary for stable maritime satellite communications services. Thus, a ϵ_{min} below 10° is assumed to be unacceptable. However, if the average daily time with elevation angle under 10° , $t_{\epsilon < 10^\circ}$, is short a high ϵ_{mean} can compensate somewhat for the low ϵ_{min} . The constellation alternatives with ϵ_{mean} above 20° and $t_{\epsilon < 10^\circ}$ under 30 min/d have, therefore, been evaluated to have an acceptable elevation angle performance.

The evaluation of elevation angle performance shows a large difference between the fifteen constellation alternatives. Constellations that have been evaluated to have an inadequate elevation angle performance have a serious drawback. They can not be completely ruled out, but they need to excel in other areas to have a chance in the final selection. The poor elevation angle performance must then be traded against other properties. Reducing the

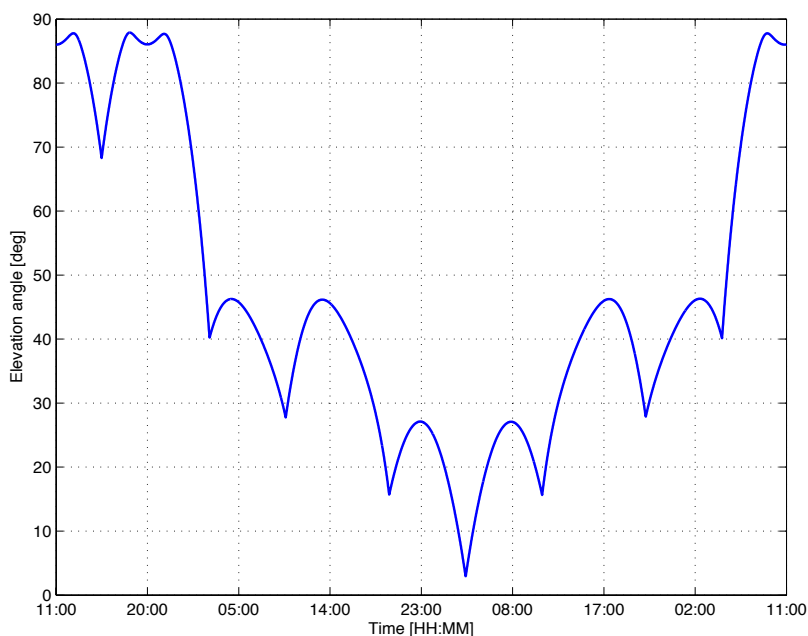

Figure 5.4: Plot of the elevation angle observed from the worst case position over a 72 h period for 18H2S2P. ϵ_{min} is very low, but the large elevation angle range result in a fairly good ϵ_{mean} .

coverage area to the requirement found in Chapter 2.3 will result in adequate elevation angle performance for all the constellation alternatives. For some of the poorly performing constellations, the elevation angle performance may to some extent be improved by increasing the eccentricity of the orbits. Such an orbit adjustment will have a negative effect on other evaluation parameters and will require trade-off considerations at the system level.

5.1.6 Azimuth angle

The earth station azimuth angle is the horizontal direction from a ground terminal towards a satellite. How this changes over time, are an important parameter in satellite communications. Especially in systems and solutions using directional user terminal antennas, this is a parameter that must be considered carefully. The system envisioned here for Arctic satellite communications is assumed to be based on a VSAT type solution. Therefore, a thorough evaluation of the azimuth angle behavior of the fifteen constellation alternatives

is necessary. The discussion and review of the azimuth angle performance of the fifteen constellation alternatives presented here is based on the changes caused by the dynamics of the satellites. Changes in azimuth angle caused by user movement are regarded as inherent for all the constellation alternatives.

How the azimuth angle changes over time vary between the different constellations, but none of the fifteen constellation alternatives can provide a constant azimuth angle. A few of the constellation alternatives have only small variations in azimuth angle, but several of them require substantial user antenna pointing changes, both when tracking an active satellite and at handover between satellites. Many users, especially mobile and maritime users, can experience the need for a wide line of sight as a constraint on continuous communications. On ships, vessels and offshore installations, good locations suitable for satellite antenna placement is limited. Thus, 360° line of sight for a maritime satellite antenna is a challenge and sometimes not even possible. Users risk periods of communications outage if a satellite is blocked by land, buildings or other structures. A constellation design that results in frequent and large changes in azimuth angle, facilitate such outages. Thus, it is evident that excessive variations in azimuth angle should be avoided if possible.

Handover between satellites can also create an azimuth angle issue. Unless both incoming and outgoing satellites are inside the user antenna beam, re-pointing of the user antenna will be necessary at handover. If user antenna re-pointing is necessary, only user terminals with two antennas can support seamless handover. Without seamless handover, continuous communications are not possible, and realtime services such as voice will be terminated or at least temporarily unavailable at handover. It is a great advantage for a constellation alternative if this can be avoided.

For evaluation of azimuth angle performance, simulations have been performed in STK. The simulation results are based on a ground station position at 60° North and at a longitude that is in the middle of two apogee longitude positions. This is the position that has the largest variations in azimuth angle at relatively low elevation angles. For many of the constellation alternatives, this is the same position as the one used to evaluate elevation angle performance, but not for all. These positions should be able to illustrate the situation well and give a good understanding of the azimuth angle performance of the various constellation alternatives. Users located inside a ground track loop will experience larger azimuth variations than the positions used in this evaluation, but that will be at elevation angles in excess of 70° to 80°. At such high elevation angles, changes in azimuth angle is not considered to be a concern.

Table 5.5: Evaluation of the azimuth angles provided by the fifteen constellation alternatives. The azimuth angles shown are the result of simulations based on the worst case position in terms of maximum azimuth angle variation at fairly low elevation angles above 60° North. AP is the number of apogee locations. NSH is the number of non-seamless handovers per day. δA_{HO} is the maximum change in azimuth angle at handover. δA_{active} is the maximum change in azimuth angle during the period a satellite is active. $\delta A/\delta t_{mean}$ is the average rate of change in azimuth angle during the active period of a satellite. A_{total} is an estimate of the total number of degrees in azimuth a user must have a clear line of sight for continuous communications.

Name	AP [#]	NSH [#/d]	δA_{HO} [°]	δA_{active} [°]	$\delta A/\delta t_{mean}$ [°/min]	A_{total} [°]	Grade
12H2S1P	4	4	164	57	0.11	169	3
12H2S2P	2	2	109	10	0.05	20	2
12H3S3P	2	0	0	19	0.08	19	1
16H2S1P	3	3	171	42	0.10	88	2
16H2S2P	3	3/2	171	58	0.11	122	3
18H2S1P	8	8/3	172	108	0.12	252	4
18H2S2P	4	8/3	161	81	0.12	190	4
24H2S1P	2	2	173	41	0.07	82	2
24H2S2P	1	2	36	36	0.05	36	2
24H3S1P	3	3	171	33	0.09	74	2
24H3S3P	1	0	0	19	0.08	19	1
24H2S1P75	2	2	152	48	0.11	96	2
24H2S2P75	1	2	21	21	0.06	21	2
24H2S1P90	2	2	180	411	0.35	360	4
24H2S2P90	1	0	0	44	0.12	44	2

The results of the simulations are shown in Table 5.5. It is important to note that 12H3S3P has two apogee positions, AP , but since both at all times will be occupied by an active satellite the number of required non-seamless handovers, NSH , is zero. Also, note that even though 24H2S1P and 24H2S2P75 only has one apogee location they have two non-seamless handovers each day. That is because handover is not performed at the ground track intersection point. This is also the case for 18H2S2P, although both the number of apogee positions and handovers per day are higher.

Constellation alternatives that supports seamless handover and has an azimuth angle variation during the period a satellite is active, δA_{active} , of less than 25° have been assessed to have a very good azimuth angle performance. Figure 5.5 show a plot of the azimuth angle as simulated over a 24 h period for one of

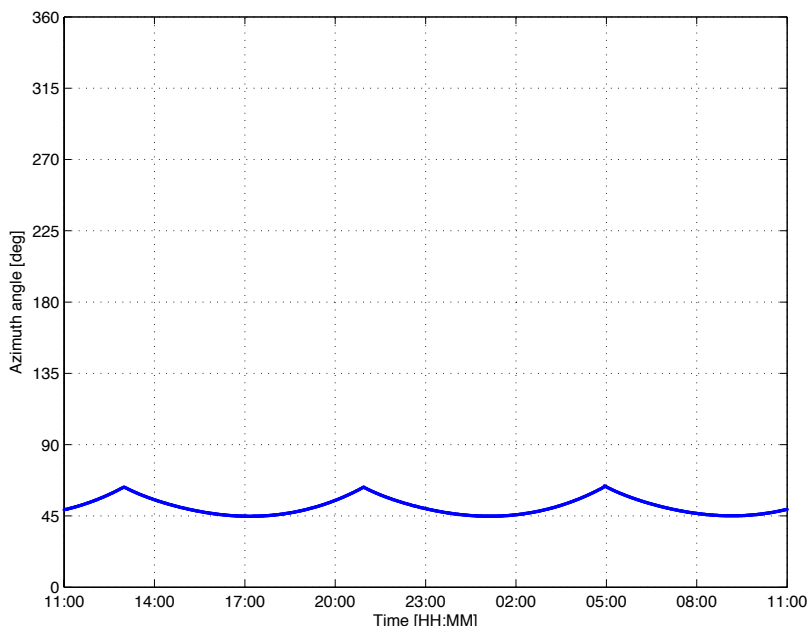

Figure 5.5: Plot of the azimuth angle observed from the worst case position over a 24 h period for 12H3S3P. The possibility to use only one apogee position and seamless handover result in a very good azimuth angle performance.

them, 12H3S3P. A δA_{active} of less than 50° has been evaluated as a good azimuth angle performance. The constellation alternatives where an estimated total number of degrees in azimuth a user must have a clear line of sight of, A_{total} , is less than 180° , have been evaluated to have an acceptable azimuth angle performance.

Two constellations, 12H2S2P and 24H2S2P75, have an A_{total} that matches that of the two constellation alternatives rated to have a very good azimuth angle performance. It is only the fact that they do not support seamless handover at all handovers that make them ineligible for an evaluation of very good. 12H2S2P has four handovers every day, and half of them supports seamless handover. A plot of the azimuth angle as simulated over a period of 24 h for this constellation alternative is shown in Figure 5.6.

There is a large variation in the azimuth angle performance of the fifteen different constellation alternatives. Only two of the constellations have been evaluated as very good. However, two others have a similar azimuth angle performance if short communications outages can be tolerated at handover

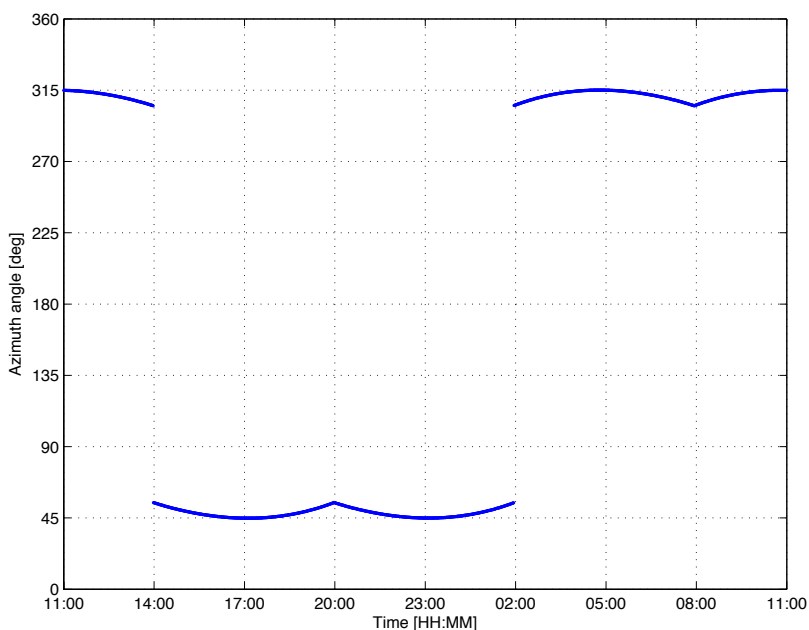

Figure 5.6: Plot of the azimuth angle observed from the worst case position over a 24 h period for 12H2S2P. The constellation has two apogee locations and both must be used, but the azimuth angle has limited variation during the active period of a satellite. Total number of degrees in azimuth used by the satellite is therefore very low.

two times a day. As an alternative, users which require continuous communications can be equipped with two user terminal antennas. In the other end of the performance range, there are constellation alternatives with many apogee positions, non-seamless handovers or large δA_{active} . Poor azimuth angle performance is very negative for a constellation alternative. It might still represent a good candidate when evaluated as a whole, but only if there are other very positive properties that are viewed as more important in a trade off.

5.1.7 Frequency coordination

In order to realize a satellite communications system, it is necessary to coordinate the frequencies to be used. The International Telecommunication Union (ITU) has allocated a number of different frequency bands for satellite communications. In theory, any of these frequencies can be used, but a new system is not allowed to interfere with an existing system. Thus, a new satellite communications system must be frequency coordinated with existing systems

that might be harmed by interference from the new system. The topic of frequency coordination in general is vast and comprehensive and will be given more consideration in a later chapter. Here, only the elements affecting the selection of a constellation alternative for the Arctic satellite communications system will be addressed and discussed.

The type of services, frequencies to be used and user terminal design are some of the key issues in frequency coordination. However, in terms of selection of a constellation the the most important properties are geography and location. In other words, where will the satellites be while active relative to different countries and users, as well as other satellite systems. Terrestrial radio systems may also play a role, but only in some frequency bands.

Considerations and evaluation of the various properties of the constellations have been made without defining the longitudinal placement of the apogee positions. Thus, it is natural to evaluate the constellation alternatives without fixing the apogee locations also in terms of frequency coordination. The key issue in terms of geographical impact on the frequency coordination is, therefore, not above which country or landmass the satellite will be operating. It is rather how easy it will be to avoid problematic areas. This is of course easier for a constellation with one apogee location and a narrow ground track loop, than for a constellation with many apogee locations and wide ground track loops.

When coordinating frequencies with other satellite systems how large a part of the sky the system uses is also an issue. A constellation where a satellite can be more or less anywhere in the sky must be coordinated as a Mobile Satellite Service (MSS). Such a coordination is difficult and demanding, and it is more or less impossible for a Mobile Satellite Service (MSS) to co-exist with another satellite system using the same frequency band. A constellation with a single apogee location and a narrow ground track loop will be on the other end of the scale. The quasi-stationary and quasi-fixed in the sky properties of such a constellation would make the frequency coordination procedure of the system similar to that of GEO systems. Frequency coordination for GEO is not a simple task, and any HEO solution will be more difficult to coordinate. However, any similarity to GEO, for example, in how the system behaves in the sky, will make the task more manageable.

Based on this reasoning, it is natural to let the evaluation of how the fifteen constellation alternatives are suited for frequency coordination rely on how they use the sky. The number of apogee locations and the size and position of the ground track loop has been used in the evaluation process. These key values

Table 5.6: Evaluation of how the fifteen constellation alternatives are suited for frequency coordination. AP is the number of apogee locations. $\delta\lambda_L$ is the number of degrees longitude a satellite span during an active period. ϕ_{min} is the latitude where a satellite nominally becomes active. A positive value is northern latitude, while a negative value is southern latitude. $\delta\phi$ is the number of degrees latitude a satellite span during an active period.

Name	AP [#]	$\delta\lambda_L$ [°]	ϕ_{min} [°]	$\delta\phi$ [°]	Grade
12H2S1P	4	1.7	53.3	10.1	2
12H2S2P	2	1.7	53.3	10.1	1
12H3S3P	2	2.5	44.0	19.4	1
16H2S1P	3	8.7	44.7	18.7	2
16H2S2P	3	8.7	44.7	18.7	2
18H2S1P	8	7.7	41.1	22.3	3
18H2S2P	4	7.7	41.1	22.3	3
24H2S1P	2	46.4	37.6	25.8	3
24H2S2P	1	46.4	37.6	25.8	3
24H3S1P	3	12.9	44.8	18.6	2
24H3S3P	1	12.9	44.8	18.6	1
24H2S1P75	2	27.6	40.8	34.2	3
24H2S2P75	1	27.6	40.8	34.2	3
24H2S1P90	2	360.0	-19.3	109.3	4
24H2S2P90	1	180.0	38.2	51.8	3

are summarized in Table 5.6. The number of apogee locations, AP , is the same as in Table 5.5 in the previous section. In Table 5.6, the longitude, $\delta\lambda_L$, and latitude, $\delta\phi$, a satellite span during an active period are shown, and they indicate how much of the sky the constellation occupies around each apogee location. The minimum latitude at which a satellite normally becomes active, ϕ_{min} , indicates whether or not frequency coordination with GEO systems will be an issue.

It is assumed that of the fifteen constellation alternatives, those that only has one or two apogee locations and a narrow ground track loop will be the easiest to frequency coordinate. More apogee locations will increase the difficulty of the frequency coordination process. While an increasing number of apogee locations increase the complexity of the frequency coordination process, a narrow ground track has the opposite effect. Eight of the constellation alternatives are assumed to be difficult to frequency coordinate due to a high number of apogee locations or large $\delta\lambda_L$. However, it should be possible to

find frequencies that can be used. The exception is 24H2S1P90 where the satellites becomes active before they cross the equator. Thus, while active the satellites will be in line with GEO satellites for a brief period. That is deemed as impossible to frequency coordinate.

Frequency coordination is extremely important as a radio communications system can not function without access to frequencies. However, there are few known precedents on how to frequency coordinate HEO satellite systems. Thus, at the present time it is difficult to assess the complexity of such a process, and if it in practice will be any difference between the constellation alternatives. Only one alternative stands out as a very poor alternative in terms of frequency coordination, and that is 24H2S1P90. Non-GEO systems must turn off all their transmitters in the periods a satellite has the potential of interfering with GEO systems. Therefore, it is difficult to see an Arctic communications system realized using the 24H2S1P90 constellation alternative as it is defined here. Increasing the eccentricity of the orbits in this constellation can solve this issue. However, as discussed previously, this will have a negative effect on other evaluation parameters.

5.1.8 Stationkeeping

To ensure reliable communications over time, the orbit of a communications satellite must be controlled and kept inside some defined boundaries. The operation of controlling the orbit within these boundaries is called stationkeeping. Stationkeeping is especially important for GEO satellites since most of the users have fixed antennas. If a GEO satellite strays too far from its position, those users lose their connection. Stationkeeping is also important in LEO constellations such as Iridium, but there the position relative to the other satellites in the constellation is important while the absolute position is of less importance.

The satellites in a HEO constellation do not have the same need for absolute position control as GEO satellites. Since HEO satellites are not stationary and require tracking antennas at the user terminals, they can be allowed to wander more. The need for relative position control depends on the constellations. The constellation alternatives that support seamless handover require the satellites to be at the handover point at the same time. This of course constrains the freedom of the satellite to wander from their optimal position before the orbit is corrected. Constellations that do not support seamless handover are not bounded by such constraints as time and accessibility are

more important than an accurate position.

In Chapter 4, the perigee drift caused by the oblateness of the earth was considered. That is the dominant perturbing force acting on a HEO satellite. However, there are also other forces that perturb the orbit of a satellite. Most notably are the gravitational pull from the Sun and the Moon. Additionally orbits with a low perigee altitude will experience atmospheric drag. The gravitational pull from the Sun and the Moon will affect the inclination, but will also cause minor drift of the argument of perigee and RAAN. Various stationkeeping maneuvers must be performed regularly to correct for these perturbations. Atmospheric drag applied around perigee will lower the apogee altitude and reduce the orbital period. However, atmospheric drag is negligible at altitudes above 1000 km and will not be an issue for any of the fifteen constellation alternatives [11, 15].

The constellation alternatives with critically inclined orbits will in theory not experience perigee drift caused by the oblateness of the earth. In practice there probably will be some drift, which is mainly due to the fact that the inclination will be changed by other perturbing forces. However, here it is assumed that the inclination will be kept close enough to the critical inclination that perigee drift due to inclination imperfections is negligible. In the constellation alternatives using inclination of 75° and 90°, the oblateness of the earth will cause perigee drift. The yearly perigee drift, $\Delta\omega_{J_2}$, for these four constellations can be found using Eq 4.1 from Chapter 4. Those results can then be used in Eq 4.3 to estimate the yearly ΔV required to correct for the perigee drift caused by the oblateness of the earth, ΔV_{J_2} . The results are provided in Table 5.7.

Third body interactions such as the gravitational forces of the Sun and the Moon will cause perturbations in a satellite orbit. In GEO, the most important effect of the third body interactions is the inclination drift. However, for non-circular orbits also the RAAN and argument of perigee is affected. The satellites in the HEO constellations evaluated here will all experience these perturbations. How the inclination of HEO orbits changes due to third body interactions is a complex issue and difficult to analyze analytically. In this study, it is assumed that inclination of the HEO constellations in question will be affected by perturbations in a similar manner as GEO satellites. Therefore, a ΔV of 55 m/s per year is assumed to be necessary to ensure the HEO satellites keep their intended inclination as discussed in section 4.1.3.

The Lagrange planetary equations can be used to find analytical expressions for approximate values of the rotation of RAAN, $\Delta\Omega$, and argument of perigee,

Table 5.7: Evaluation of the stationkeeping performance of the fifteen constellation alternatives. Δw_{J_2} and ΔV_{J_2} is the perigee drift per year caused by the oblateness of earth and the ΔV required to correct that drift. $\Delta\Omega_{sun}$ and $\Delta\Omega_{moon}$ indicate the yearly RAAN rotation caused by the Sun and the Moon. Δw_{sun} and Δw_{moon} is average values for the perigee rotation caused by the Sun and the Moon, while ΔV_{sun} and ΔV_{moon} are the ΔV necessary to correct for those perturbations. All the ΔV elements are summed together in ΔV_{sum} . MLP is the Maneuver Lifetime Percent referenced to a typical GEO satellite.

Name	Δw_{J_2} [°/year]	ΔV_{J_2} [m/s]	$\Delta\Omega_{sun}$ [°/year]	$\Delta\Omega_{moon}$ [°/year]	Δw_{sun} [°/year]	Δw_{moon} [°/year]	ΔV_{sun} [m/s]	ΔV_{moon} [m/s]	ΔV_{sum} [m/s]	MLP [%]	Grade
12H2S1P	-	-	0.32	0.71	0.10	0.23	3.67	8.06	11.73	82.4	2
12H2S2P	-	-	0.32	0.71	0.10	0.23	3.67	8.06	11.73	82.4	2
12H3S3P	-	-	0.32	0.69	0.10	0.22	3.49	7.66	11.16	83.1	2
16H2S1P	-	-	0.28	0.61	0.06	0.13	1.15	2.53	3.69	93.7	1
16H2S2P	-	-	0.28	0.61	0.06	0.13	1.15	2.53	3.69	93.7	1
18H2S1P	-	-	0.29	0.63	0.05	0.12	0.84	1.84	2.67	95.4	1
18H2S2P	-	-	0.29	0.63	0.05	0.12	0.84	1.84	2.67	95.4	1
24H2S1P	-	-	0.35	0.77	0.05	0.12	0.68	1.49	2.17	96.2	1
24H2S2P	-	-	0.35	0.77	0.05	0.12	0.68	1.49	2.17	96.2	1
24H3S1P	-	-	0.29	0.63	0.02	0.05	0.15	0.34	0.49	99.1	1
24H3S3P	-	-	0.29	0.63	0.02	0.05	0.15	0.34	0.49	99.1	1
24H2S1P75	2.38	29.03	0.20	0.44	0.15	0.33	1.86	4.09	34.98	61.1	4
24H2S2P75	2.38	29.03	0.20	0.44	0.15	0.33	1.86	4.09	34.98	61.1	4
24H2S1P90	2.50	6.74	0.00	0.00	0.28	0.61	0.75	1.66	9.15	85.7	2
24H2S2P90	3.23	33.48	0.00	0.00	0.28	0.58	2.72	5.96	42.16	56.6	4

$\Delta\omega$. These equations are:

$$\Delta\Omega = \frac{\delta\Omega}{\delta t} = -\frac{3}{8} \frac{n_3^2}{n} \frac{1 + \frac{3}{2}e^2}{\sqrt{1-e^2}} (3 \cos^2(i_3) - 1) \cos i \quad (5.4)$$

$$\Delta\omega = \frac{\delta\omega}{\delta t} = \frac{3}{8} \frac{n_3^2}{n} \frac{1 - \frac{3}{2} \sin^2(i_3)}{\sqrt{1-e^2}} (4 - 5 \sin^2(i) + e^2) \quad (5.5)$$

where n_3 and i_3 are the mean motion and inclination with respect to the Earth equatorial plane of the third body. The rest of the variables refers to the orbital elements of the satellite [15]. These two equations do not take into account variations due to orientation of the orbital plane with respect to the lunar orbit and the ecliptic plane. Thus, the resulting values are only averages, but they give a valuable understanding of how the Moon and the Sun affect these two orbital elements. In Table 5.7, the drift in the orbital parameters induced by the Sun and the Moon for the fifteen constellation alternatives are shown.

Nodal regression, or the rotation of RAAN, can lead to a movement of the apogee locations. However, the $\Delta\Omega$ induced by the Sun and the Moon is very low, with a rotation only just above 1° per year in the constellation alternative that is most affected. As briefly mentioned in Chapter 4, this effect can be neutralized by small adjustments in the orbital period. Just a few seconds shorter orbital period is enough to ensure that the ground track stays recurring even under the influence of the third body interactions [9]. Thus, RAAN rotation caused by the gravitational force of the Sun and the Moon have no impact on the stationkeeping propellant budget.

The perigee drift induced by the influence of the Sun and the Moon is also quite small. However, this drift must be corrected and countered by orbit maneuvers. Even though the combined perigee drift caused by the Sun and the Moon ranges from only 0.07° to 0.86° per year for the constellation alternatives, it can incur a substantial ΔV cost. An estimate of this ΔV cost can be calculated using Eq 4.3. The perigee drift caused by the Sun and the Moon as well as the ΔV required to correct the orbit is provided in Table 5.7. These two ΔV values can be added together since the rotation induced by the Sun and the Moon goes the same way. The J_2 caused perigee drift in the four non-critically inclined constellations also rotates in the same way, so ΔV_{J_2} can also be added together with ΔV_{sun} and ΔV_{moon} . The result is ΔV_{sum} , which is provided in Table 5.7.

In order to evaluate the stationkeeping performance of the constellation alternatives, it is necessary to understand the effect stationkeeping has on the

satellite maneuver lifetime. The simplest way to do this is to compare the constellation alternatives with a typical GEO reference. This comparison has been done through the use of the Maneuver Lifetime Percent (MLP), which is defined as:

$$MLP = \frac{\Delta V_{GEO}}{\Delta V_{sum} + \Delta V_{GEO}} \cdot 100\% \quad (5.6)$$

where ΔV_{GEO} is the ΔV used for stationkeeping on a GEO satellite. In the MLP values for the fifteen constellation alternatives shown in Table 5.7, a ΔV_{GEO} of 55 m/s per year has been used. The constellations utilizing critically inclined orbits have a MLP from about 82% to 100% while the constellations with higher inclination have a MLP of roughly 60%. 24H2S1P90 is the exception with a MLP of close to 86% because of the low eccentricity.

Stationkeeping performance is an important parameter to consider as part of the constellation selection process. A poor stationkeeping performance, or low MLP, will reduce the satellite maneuver lifetime. For a HEO satellite which is most effective when the apogee is located over the intended position, a reduced maneuver lifetime will most likely result in a reduced operational lifetime. Investments must then be recuperated over a shorter time. Constellation alternatives with poor stationkeeping performance can not be disregarded outright, but they will need very compelling reasons to be selected. Those reasons must weigh up for a significant system cost increase due to the reduced satellite maneuver lifetime.

5.1.9 Initial operational phase

The term initial operational phase is here used for the time from first launch to the system reaches full operational status. For satellite systems consisting of multiple satellites, this period can be important for the profitability of the system. System functionality during this phase has a profound impact on the early user uptake. The length of this phase influence the operational lifetime of the system as a whole. A long initial operations phase with little or no functionality to offer users will effectively reduce the satellite lifetime with the length of this phase. On the other hand, there are the systems that have a short initial operations phase with a high functionality level. Such a system will be able to take advantage of almost the whole satellite's lifetime.

In LEO and Medium Earth Orbit (MEO) systems with several tens of satellites, the initial operational phase is crucial. Such systems will usually have poor functionality, both in terms of coverage and services available until most of

Table 5.8: Evaluation of the initial operational phase properties of the fifteen constellation alternatives. The key evaluation criteria is the number of launches required before full temporal coverage is reached.

Name	Planes [#]	Minimum temporal coverage after			Grade
		1 launch [%]	2 launches [%]	3 launches [%]	
12H2S1P	1	100	100	-	1
12H2S2P	2	50	100	-	2
12H3S3P	3	50	100	200	2
16H2S1P	1	100	100	-	1
16H2S2P	2	50	100	-	2
18H2S1P	1	100	100	-	1
18H2S2P	2	50	100	-	2
24H2S1P	1	100	100	-	1
24H2S2P	2	50	100	-	2
24H3S1P	1	100	100	-	1
24H3S3P	3	34	67	100	3
24H2S1P75	1	100	100	-	1
24H2S2P75	2	50	100	-	2
24H2S1P90	1	100	100	-	1
24H2S2P90	2	50	100	-	2

the satellites in the system are in orbit. In addition to poor functionality, this phase often extends over several years due to the large number of satellites in the constellation. Each satellite launch only brings a few satellites into orbit, and a launch provider will usually need a month or two to prepare the next launch. The constellation alternatives in question here only consists of two or three satellites. Thus, it should be possible to limit the initial operational phase to last only a few months with limited difference between the constellation alternatives.

The constellations with the satellites in a single orbital plane have the potential of launching the satellites in one launch. After a brief period of test and validation of the satellites and the system, full operational capabilities should be reached within a month or two of the launch. This is more or less the minimum of what can be expected from a complex satellite communications system, regardless of the number of satellites it employs. Continuous coverage of the area of interest can be accomplished with a single launch. This is the case for seven of the constellation alternatives as shown in Table 5.8.

With satellites in individual planes the length of the initial operational phase

increase. Two orbital planes will in general require two launches. This is likely to more than double the length of the initial operational phase. Thus, a period of 4 to 8 months must be expected from first launch until full operational status is reached. As indicated in Table 5.8, full temporal coverage is possible with two launches for all the six constellation alternatives with two orbital planes.

In constellations with three orbital planes, three launches will be necessary. That will extend the initial operational phase further, possibly up to a year. The two constellations with three orbital planes have different functionality during the initial operational phase. Even though it is not fully operational before all three satellites are launched, 12H3S3P can provide full temporal coverage of the area of interest already after two launches. 24H3S3P can not provide continuous coverage before the constellation is complete after three launches.

A single launch is also a possibility for constellations with multiple orbital planes. However, to reach the desired orbits after a single launch, one or more of the satellites in the constellation must change the orbital plane. This can be achieved directly through orbital maneuvers, but that will require a large amount of propellant to be used. This is propellant that could have been used to extend the maneuver lifetime of the satellite. Hence, this do not seem to be a good way to shorten the initial operational phase.

Alternatively the plane can be changed by taking advantage of orbit perturbations. With small changes in the orbital period, the RAAN will begin to drift at a different rate than a co-launched satellite. When the RAAN has drifted far enough the period is changed back, and the constellation is in the desired state. It does not require much propellant to change the orbital plane in this manner, but it will take time. Probably about the same time it will take to wait for additional launches. Thus, a single launch, followed by perturbation induced drift to change to the correct orbital plane is not likely to shorten the initial operational phase. It is more interesting to use this technique if it is decided after launch of a two satellite constellation to expand it to a three satellite constellation.

5.2 Constellation discussion

The evaluation results for the fifteen constellation alternatives are summarized in Table 5.9, and it can be observed that none of the constellation alternatives stands out as an obvious best choice. All the constellations have strengths and weaknesses. Thus, the selection of constellation for an Arctic satellite

communications system must be based on trade-offs between the evaluated properties. Calculation of the average rating is one way of comparing the total performance of the constellations. However, the simple average of the ratings are not a trustworthy way to select the best constellation. The average rating do not take into account the weighting of the different properties and can, therefore, give an erroneous impression of the overall performance of the constellation alternatives.

A constellation with inadequate performance on one of the properties must excel in other areas to be of interest. Therefore, it is logical to first look at the constellation alternatives that have been given a grade of 4. If they do not outperform other constellation alternatives on one or more properties, they should be eliminated. Both of the 18 h alternatives have been evaluated to have an unacceptable azimuth angle performance. Comparison between these two alternatives with the 16 h alternatives indicate similar performance on all other properties except frequency coordination and azimuth angle, and there the 16 h alternatives are better. The two 18 h constellation alternatives can, therefore, be disregarded.

Six of the eight 24 h constellation alternatives have also been evaluated to at least one grade of 4. 24H2S2P was given a grade of 4 for its elevation angle performance. It has similar performance as 24H2S1P, except in terms of launch cost factor, elevation angle and initial operational phase where it has a poorer rating. 24H2S2P75 is in the same situation, but with the addition of an inadequate stationkeeping performance. 24H2S1P75 also has an overall performance comparable to 24H2S1P. It has a slightly better elevation angle evaluation, but the stationkeeping performance is inadequate. The evaluation of 24H2S2P90 indicate a radiation environment better than 24H2S1P, but the launch cost factor is higher. In addition, the elevation angle and stationkeeping performance have been evaluated as inadequate. Thus, 24H2S2P, 24H2S1P75, 24H2S2P75 and 24H2S2P90 can be eliminated from further consideration.

24H2S1P90 has positive evaluations of several properties. However, the elevation and azimuth angle performances are not good. The biggest problem is, however, the frequency coordination issue, as this constellation will require coordination with GEO systems. Therefore, it is difficult to see how a communications system using the 24H2S1P90 can be realized. Hence, 24H2S1P90 is not considered further.

The last constellation that has been evaluated with an unacceptable rating is 24H3S3P for its elevation angle performance. Since the constellation consists

Table 5.9: Evaluation results for the fifteen constellation alternatives summarized. The section numbers on the second row indicate in which section the properties are discussed and evaluated. FSL and IOP is abbreviations for the free space loss and the initial operational phase.

Name	Radiation 5.1.2	Launch 5.1.3	Coverage 5.1.4	Elevation 5.1.5	Azimuth 5.1.6	Frequency 5.1.7	Stationkeeping 5.1.8	IOP 5.1.9
12H2S1P	3	1	2	1	3	2	2	1
12H2S2P	3	2	2	2	2	1	2	2
12H3S3P	3	3	1	1	1	1	2	2
16H2S1P	2	1	2	2	2	2	1	1
16H2S2P	2	2	2	3	3	2	1	2
18H2S1P	2	1	2	2	4	3	1	1
18H2S2P	2	2	2	3	4	3	1	2
24H2S1P	2	1	2	2	2	3	1	1
24H2S2P	2	2	2	4	2	3	1	2
24H3S1P	1	2	2	2	2	2	1	1
24H3S3P	1	3	2	4	1	1	1	3
24H2S1P75	2	1	2	1	2	3	4	1
24H2S2P75	2	2	2	4	2	3	4	2
24H2S1P90	1	2	2	4	4	4	2	1
24H2S2P90	1	2	2	4	2	3	4	2

of three satellites, it is logical to compare it with the 12H3S3P alternative. With the exception of the radiation environment and stationkeeping performance, 24H3S3P is inferior in all categories investigated here. Low radiation is very positive, but this is not believed to make up for the other weaknesses of the 24H3S3P alternative. Therefore, it is removed from further consideration.

All the seven remaining constellation alternatives have a performance that are acceptable or better for all the properties studied here. Thus, the task of ruling out alternatives is getting more difficult. However, from Table 5.9 it can be observed that four of seven constellation alternatives have similar performance characteristics. These are the two 16 h alternatives and the last two 24 h alternatives. Of the two 16 h alternatives, 16H2S1P has received a better or equal evaluation as 16H2S2P. 16H2S1P also comes out as the superior alternative when compared to 24H2S1P, which is assumed to be more difficult to frequency coordinate. The evaluation grades of 16H2S1P and 24H3S1P differ only in terms of the radiation environment and launch cost factor. 24H3S1P has the best radiation environment, but is inferior when it comes to launch cost factor. With three satellites in the constellation, it will also have a higher total cost. As a result, 16H2S2P, 24H2S1P and 24H3S1P are not considered further as constellation alternatives of interest.

This leaves the single plane 16 h constellation and the three 12 h constellations as relevant alternatives. The 12 h constellation alternatives all have a worse radiation environment and an inferior stationkeeping performance compared to that of 16H2S1P. Both of these factors have the potential of reducing the lifetime of the satellites. Satellite degradation due to radiation can be minimized through the use of appropriate shielding and modern technology. Any reduced satellite lifetime for the 12 h constellations from radiation, is very likely to be less than the reduction caused by stationkeeping requirements when comparing with the 16 h alternative. Thus, the radiation environment is assumed to have a negligible impact on the actual satellite lifetime differences between the remaining four constellation alternatives.

From the stationkeeping cost estimations in section 5.1.8, a maneuver lifetime difference between the 12 h and 16 h alternatives of around 10 % can be derived. Given the uncertainty in those calculations, this difference has not been regarded as large enough to have a paramount impact on the constellation selection. The stationkeeping performance is not disregarded, but it is not seen as important as the more communications specific properties.

When looking closely at the communications specific properties such as coverage, elevation angle, azimuth angle and frequency coordination, the 12H3S3P

constellation stands out as the best. It is also the only alternative that support seamless handover at every handover. The disadvantage of 12H3S3P is the launch cost factor and the fact that it consists of three satellites. That is bound to result in a higher total system cost than the other alternatives. However, since 12H3S3P provide dual coverage it is possible with load sharing between the two active satellites. This adds flexibility and allow reduced size of the satellites compared to the other constellation alternatives. Smaller satellites cost less, so even though 12H3S3P has 50 % more satellites, the cost of the constellation is assumed to be less than 50 % higher than those with only two satellites. Continuous dual coverage also adds redundancy, which can be expected to reduce the insurance cost. Insurance costs are considered further in section 9.6. Based on this reasoning the additional satellite needed in the 12H3S3P constellation is not considered a serious drawback.

This leaves the launch cost factor as the major reason for not selecting 12H3S3P as the preferred constellation alternative. When it comes to the launch cost factor, it is important to remember that it is based on the minimum number of launches required to orbit the constellation. Hence, if it is found that it is not cost effective to launch a single plane constellation in one launch, the apparent launch cost factor advantage disappears. A move to individual launches may be prompted by launcher availability or a high cost of moving up to the large launcher that support a dual launch. Important elements not taken into account in the launch cost factor are satellite mass and dimension. The smaller satellites required in the 12H3S3P constellation can be launched on smaller and less expensive launchers. Thus, the argument can be made that even though three launches are necessary, the launch costs incurred by selecting 12H3S3P will not be dramatically higher than for the other constellation alternatives.

An alternative to launching a satellite system using a 12H3S3P constellation directly is to use a 12H2S2P as a stepping stone. It has the same radiation environment and stationkeeping performance, and an overall good communications performance. With one satellite less in the constellation, it will be less expensive to launch. Satellites with a moderate capacity can be used to capture the limited market potential of the first years. When the capacity demand increases the orbital plane of one of the satellites can be changed, and a third satellite launched. The result is the 12H3S3P constellation, and twice the capacity. From a commercial business perspective, this is an enticing scenario and a likely way to implement a three satellite constellation.

During this discussion, it has been argued that the radiation environment,

launch cost factor and stationkeeping performance differences between the 12 h and 16 h orbit constellation alternatives are less important than the more communications specific properties. Increased understanding and knowledge about these three properties and their effect on system cost might change this argument. Then it is likely that the 16H2S1P constellation will be the preferred alternative based on its overall good rating. It is a good alternative that deserves serious consideration due to a better radiation environment and stationkeeping performance than the 12 h alternatives.

In the system considerations in the following chapters, the 12H3S3P constellation will be used as the base case. The selection of a constellation was necessary to limit the scope for further system considerations. However, the potential for lower system cost and longer satellite lifetime with the 16H2S1P constellation should not be ignored. That constellation is regarded as a highly interesting alternative for satellite based communications coverage of the Arctic. It should be noted that the results and calculations presented in the following chapters use the 12H3S3P constellation as a base case. To some degree they can also be applicable to a system solution using the 16H2S1P constellation.

Chapter 6

Considerations on frequency bands

A key issue in the design of a satellite communications system is the carrier frequency. Numerous design choices and trade-offs depend on the frequency band used for communications, both for satellite and ground segment. A low frequency is advantageous in terms of propagation and availability, but a higher frequency allows reduced antenna dimensions without decreased antenna gain. Compatibility with other systems, especially GEO systems, is also an important subject when considering which frequency band to use for broadband satellite communications in the Arctic.

This chapter discusses appropriate frequency bands for a HEO satellite based Arctic communication system. First, a brief discussion on frequency alternatives are given, and the K_u and K_a bands are confirmed as viable alternatives. The propagation properties of these two frequency band alternatives are then considered. Those findings are considered together with GEO compatibility issues, possible antenna dimensions and market potential.

6.1 Frequency alternatives

The frequency regulations issued by the ITU identifies seven frequency bands allocated to MSS, Fixed Satellite Service (FSS) and Broadcasting Satellite Service (BSS). Those are L, S, C, X, K_u , K_a and Q/V band. Of them, the MSS allocations in L and S band are too narrow banded as well as unavail-

Table 6.1: Summary of the exact frequencies used to evaluate the two frequency bands identified as interesting.

Frequency band	Downlink frequency [GHz]	Uplink frequency [GHz]
K _u	11.0	14.0
K _a	20.0	29.0

able for the required broadband applications. The FSS allocation in X band is reserved for military and governmental use only and is, therefore, not an alternative for a commercial system. Q/V band usage today is very limited with long term propagation studies planned. In the future, when developments have progressed, and the technology is more mature, Q/V band will be more interesting, but currently it is deemed as not ready for commercial communications services. Historically C band has been used primarily for FSS while K_u band has seen both FSS and BSS usage. Adoption of K_a band is fairly recent and has primarily been for FSS.

The radio regulations stipulate minimum antenna diameter for maritime user terminals in C band of 2.4 m for compatibility with GEO requirements. For K_u band, the minimum antenna diameter is half of that while K_a currently do not have such stipulations. Small antenna dimensions are advantageous for maritime deployment as it allows equipment to be installed on smaller vessels. Thus, K_u and K_a band have been deemed to be the most relevant for a satellite based Arctic communications system. A more thorough review of the regulatory issues concerning frequencies for satellite communications can be found in Appendix D.

6.2 Free space loss

The largest distance between the earth stations and satellite will occur when the satellite is at apogee. Within the extended coverage area, an earth station located at 60° northern latitude and at the same longitude as the opposite apogee will be the furthest away from the satellite. The distance between an earth station located there and a satellite at apogee is approximately 42 325 km. Normally users at that location will be served by the active satellite close to the opposite apogee as the dual coverage is mainly provided for redundancy. If only half of the total coverage area is taken into account, the worst

Table 6.2: Summary of calculated free space loss for the four carrier frequencies. A distance of 40 764 km is used in the calculations. This corresponds to the distance between an earth station located at 60° North and at the longitude in the middle of the two apogee locations.

Frequency [GHz]	Free space loss [dB]
11	205.5
14	207.6
20	210.7
29	213.9

case position in terms of distance is at 60° northern latitude and at the longitude in the middle of the two apogee locations. With the satellite at apogee, the distance there is approximately 40 775 km. In terms of free space loss, the difference is only 0.3 dB. Thus, it does not introduce any significant error to use this value as the worst case distance. The worst case free space loss applicable to the system is summarized in Table 6.2 for the four carrier frequencies.

6.3 Propagation effects

A radio signal propagating from a satellite to earth, and from earth to a satellite, will be influenced by various effects and phenomena. Some propagation effects vary with time while others are more or less constant over time. The time variable effects include tropospheric and ionospheric scintillation, Faraday rotation, depolarization, clouds and precipitation. These effects are recognized by signal fading with variable amplitude depending on the effect, and its severity. Water vapor and oxygen in the atmosphere absorbs some of the signal power. At a fixed ground station position and elevation angle this effect is fairly constant, and it is the predominant propagation effect that are regarded as independent of time.

All these effects are frequency dependent, both those that are dependent and independent of time. With signal fades impacting the system availability, it is wise to look at how severe the effects are in the various frequency bands. In the following section, the various propagation effects will be considered in terms of their impact in the frequency bands identified as interesting and listed in Table 6.1. Increased radio noise caused by atmospheric absorption and rain attenuation is addressed in section 7.9.

Table 6.3: Atmospheric attenuation towards zenith from sea level and an elevation angle of 26.4°. A standard atmosphere is assumed.

Frequency band	Zenith		26.4° elevation	
	Downlink [dB]	Uplink [dB]	Downlink [dB]	Uplink [dB]
C	0.0	0.0	0.1	0.1
K _u	0.1	0.1	0.1	0.2
K _a	0.3	0.3	0.6	0.6

6.3.1 Atmospheric absorption

ITU have issued a recommendation on how to estimate the atmospheric attenuation. An approximate estimation of atmospheric attenuation towards zenith can be found for the frequencies under evaluation here using this recommendation. The results are shown in Table 6.3. Only ground stations positioned at the sub-satellite point will see the satellite in zenith. The path through the atmosphere increases in length with a decreasing elevation angle. A longer signal path through the atmosphere lead to more absorption and a larger attenuation. For elevation angles between 5° and 90°, the atmospheric attenuation can be estimated using the zenith attenuation and the cosecant law [19]. The lowest elevation angle experienced within the extended coverage for the 12H3S3P constellation was in section 5.1.5 found to be 26.4°. This elevation angle represents the worst case atmospheric attenuation. The worst case estimates for the four frequencies in question are listed in Table 6.3.

6.3.2 Rain attenuation

The presence of rain in the signal path will absorb and scatter a radio wave. Absorption and scattering reduce the energy and attenuate a radio signal. At low frequencies, this attenuation effect is negligible, but at higher frequencies rain can have a drastic impact on a radio link. This is especially true above 10 GHz where rain is considered to be the dominant propagation phenomenon [20, 21].

ITU have issued a recommendation on how to predict rain attenuation in a satellite communications system [22]. The recommendation stipulates a prediction procedure that is valid up to 55 GHz. Based on location specific parameters, attenuation values that will be exceeded for certain percentages

of time can be predicted. These location specific parameters include the rain height, rainfall rate and the elevation angle.

Above 60° northern latitude, the rain height can be assumed to be somewhere between 1 km and 2.5 km. The exception are above central Greenland and Eastern Siberia where it can be higher than 3 km [23]. However, those are high-altitude areas so the effective rain height can be assumed to be in the same range as the rest of the region above 60° North. Thus, a conservative rain height estimate for the extended coverage area is assumed to be 2.0 km, and this value is used here.

The Arctic and high latitude areas are almost like a desert in terms of precipitation. With a dry and cold climate it is raining substantially less in the high North than further south, and most of the precipitation comes in the form of dry snow or drizzle [24]. In radio wave propagation, the rainfall rate is defined as a rain intensity in mm/h that are exceeded for a certain percentage of time. The rain attenuation prediction procedure recommended by ITU uses a rainfall rate based on the rain intensity exceeded in less than 0.01 % of the time. ITU has also issued a recommendation on the rainfall rate to use in the prediction of rain attenuation. Above 70° North, the rainfall rate is mainly within the range of 10 mm/h to 20 mm/h. Off the coast of northern Norway, the rainfall rate can be as high as 30 mm/h to 35 mm/h. Between 60° and 70° North, the rainfall rate are also mostly in the range of 10 mm/h to 20 mm/h with the exception of the ocean and coastal areas between Greenland and Norway. In that area, the rainfall rate varies from 30 mm/h to 55 mm/h with a peak of the western coast of Norway at around 60 mm/h [25].

A recent analysis of short term precipitation in Norway performed by the Norwegian Meteorological Institute (NMI) indicates that the rainfall rates recommended by ITU are too high. Through analysis of historical rainfall measurements over the period from 1967 to 2010, statistical rainfall intensity maps were created. In northern Norway, the rainfall intensity exceeded 15 mm/h less than 0.01 % of the time. As a matter of fact, in the ten year period between 2000 and 2010 the rainfall intensity exceeded 20 mm/h on only one occasion. On the western coast of Norway, the analysis showed an even larger deviation from the ITU recommendation. In the most rainfall intense areas, the rate exceeded 25 mm/h to 28 mm/h in less than 0.01 % of the time [26].

Due to the variation in rainfall rate across the extended coverage area of the system, it is appropriate to assess the rain attenuation of the various frequency alternatives at three latitudes with different rainfall rates. Based on the recent NMI analysis it is assumed that the latitudes 80°, 70° and 60°

North corresponds to rainfall rates of 10 mm/h, 15 mm/h and 25 mm/h exceeded in less than 0.01 % of the time.

Because of the dynamic conditions of the satellites it is assumed to give unrealistically high attenuation predictions if the minimum elevation angle is used in calculations. An ITU recommendation suggests a procedure based on dividing the operational range of elevation angles into small increments. After prediction of the rain attenuation for each increment, the total prediction values can be found based on the percentage of time the satellites are within each increment [22]. This approach is very cumbersome. Furthermore, it is assumed to give unreliable result as it relies heavily on concurrent events and correlation. Use of the average elevation angle will give less complex calculations, and it is assumed to provide adequate accuracy to the rain attenuation predictions.

In section 5.1.5, an earth station using the 12H3S3P constellation at the 60° North worst case position was simulated to have a minimum elevation angle of 26.4°, and an average elevation angle of 40.0°. The same simulations show that the worst case positioned earth stations at 70° and 80° North will experience minimum elevation angles of 30.8° and 33.7°, respectively. Average elevation angles are significantly higher with 46.3° and 50.7° at 70° and 80° North.

The rain attenuation predictions for the three different latitudes are shown in Tables 6.4, 6.5 and 6.6. For each latitude and frequency, the predictions are given for three percentages of time. Over the course of one year, 0.01 % equates to as little as 53 min while 0.1 % equals only 8 h and 48 min. 1 % of a year is about 3.7 days. Based on Figure 5.3 it is clear that there are periods with an elevation angle well below average, but those periods are brief. In periods with higher elevation angle than the average, the attenuation will be less severe. Therefore, the attenuation levels for a given percentage of time is expected to be less than those indicated in Tables 6.4, 6.5 and 6.6.

More accurate predictions than those presented here require correlation between periods of rain and satellite positions. The dynamics of the satellite constellation and many of the earth stations, such as the maritime users, result in a complex situation in terms of attenuation predictions. Satellites, users and weather systems will move independently of each other. This opens up a number of possible concurrent events which will be impossible to predict accurately. Attempts to model and simulate the system at such a level of detail might provide more accurate rain attenuation predictions, but such calculations are beyond the scope of this study.

It should also be noted that to a large extent the precipitation in the Arctic and

Table 6.4: Prediction of rain attenuation exceeded at 80° northern latitude for a given percentage of time. An average elevation angle of 50.7° is used on the calculations.

Frequency [GHz]	0.01 % [dB]	0.1 % [dB]	1 % [dB]
11	0.9	0.2	0.0
14	1.7	0.5	0.1
20	3.6	1.1	0.2
29	7.2	2.3	0.5

Table 6.5: Prediction of rain attenuation exceeded at 70° northern latitude for a given percentage of time. An average elevation angle of 46.3° is used on the calculations.

Frequency [GHz]	0.01 % [dB]	0.1 % [dB]	1 % [dB]
11	1.4	0.4	0.1
14	2.6	0.8	0.2
20	5.5	1.7	0.4
29	10.9	3.7	0.9

Table 6.6: Prediction of rain attenuation exceeded at 60° northern latitude for a given percentage of time. The average elevation angle of 40.0° is used on the calculations.

Frequency [GHz]	0.01 % [dB]	0.1 % [dB]	1 % [dB]
11	2.6	0.8	0.2
14	4.7	1.5	0.3
20	9.2	3.0	0.7
29	17.1	6.0	1.5

high North is in the form of snow [24]. Propagation experiments performed in Norway indicate that dry snow has a negligible effect on frequencies below 30 GHz [27]. This reduces the attenuation levels for a given percentage of time additionally. Thus, it is assumed here that the 0.1 % attenuation values in Tables 6.4, 6.5 and 6.6 indicate the predicted rain attenuation exceeded in less than 0.1 % of the time.

In satellite communications, fades on the downlink are more difficult to handle than on the uplink. Earth stations can usually utilize uplink power control techniques to mitigate the fading effects of rain. The available power is more limited onboard satellites, which makes it more difficult to counter rain attenuation with increased transmitting power. Thus, rain attenuation on the downlink frequency can be more severe than on the uplink in a satellite system.

At 80° northern latitude, the predicted rain attenuation at the K_a band downlink frequency of 20 GHz is only 1.1 dB. The rain attenuation predictions for 70° North indicate slightly higher attenuation, but not significantly. In the K_u band, the rain fade estimate increase to 0.4 dB and in the K_a band to 1.7 dB. Such rain fades can be managed by added link margins, but at the cost of a slightly more advanced satellite with higher power or spot beams. An alternative to fixed link margins is to employ an Adaptive Coding and Modulation (ACM) scheme. Changing to a lower order modulation scheme combined with a higher code rate will increase the link margin at the expense of reduced throughput. This can ensure an operative communications link also during severe rain fades. The use of ACM is discussed further in section 7.10.

The high attenuation scenario in terms of predicted rain fade inside the extended coverage area is given in Table 6.6. Those predictions are based on the average elevation angle experienced at 60° North and a rainfall rate of 25 mm/h. It is important to note that high rainfall rates are only experienced in a limited part of the coverage area [25, 26]. If the constellation is designed to have an apogee position above northern Europe as illustrated in Figure 4.16, the elevation angles experienced in those areas will be substantially higher than those used in these predictions. The values in Table 6.6 can, therefore, be assumed to be conservative for the time percentages indicated. For the K_u band downlink, the rain attenuation prediction of approximately 0.8 dB can be handled by implementing extra link margin. The necessary link margin is well within reasonable limits. For the K_a band downlink, the rain attenuation is predicted to around 3 dB. For the limited time periods and areas large rain fading levels will be experienced, this is not assumed to be a substantial drawback for usage of the K_a band.

Given the mitigation techniques available today, both the K_u and K_a bands are good frequency band alternatives even with the predicted rain attenuation levels. They certainly do not disqualify the K_u and K_a bands from usage in the proposed system. It should also be noted, that both K_u and K_a band are used for satellite communications in more southern areas with a more humid climate and higher rainfall intensity. Therefore, use of the K_u and K_a bands for an Arctic satellite communications system should also be possible.

6.3.3 Clouds, fog, snow and XPD

The most important hydrometeor effect is of course rain attenuation, which is dealt with separately above. Other hydrometeor effects include attenuation due to fog, clouds and snow as well as hydrometeor induced cross polarization. These effects are dominated by rain fading, but in some communications systems they can have an impact on the communications link.

A layer of fog will typically not extend higher than an altitude of about 150 m above the ground. Unless the elevation angle is very low, a satellite signal will have a short path through the fog. A short path through an absorptive medium, such as fog, result in a low level of attenuation. Up to 100 GHz attenuation from fog is insubstantial [21, 28].

Clouds have a larger impact than fog on the attenuation level of a radio signal. A cloud consist of small water droplets which absorb and attenuate a radio signal. The attenuation increase with frequency, but not to the same extent as rain attenuation. The total columnar content of liquid water is an important parameter in the estimation of cloud attenuation. In the high North, the climate is dry. Thus, the total columnar content of liquid water is fairly low. Cloud attenuation occur more often than rain attenuation, but it is normally very low. Typically the cloud attenuation will even in the K_a band only exceed a few tenths of a dB in less than 1% of the time [29]. This is normally not enough attenuation to have any significant impact on satellite communications.

During the discussion on rain attenuation, it was briefly mentioned that dry snow has a negligible effect on frequencies below 30 GHz. With wet snow, or sleet, the situation is different. At the core of a flake of wet snow, there is a frozen crystal structure that suspends the outer edges of water. Therefore, flakes of wet snow can appear as super sized raindrops. The result is an attenuation that is larger than the equivalent rainfall rate normally causes. Experimental work on wet snow attenuation is challenging, and the current

Table 6.7: Prediction of cross-polarization discrimination (XPD) exceeded at 60°, 70° and 80° northern latitude for 99.9% of the time. The predictions are based on the rain attenuation values estimated previously.

Frequency [GHz]	Linear polarization			Circular polarization		
	80°N [dB]	70°N [dB]	60°N [dB]	80°N [dB]	70°N [dB]	60°N [dB]
11	60.5	54.6	47.5	47.3	41.5	34.5
14	57.7	51.9	44.8	44.4	38.6	31.6
20	54.4	48.4	41.5	41.1	35.2	28.5
29	51.2	45.5	39.3	38.0	32.3	26.2

adopted methods need further refinement [27, 30]. Wet snow is a regular occurrence on the Norwegian coast, mainly in early and late winter time. In other parts of the Arctic and high North with a more dry climate, wet snow is not that common. Thus, it is assumed to be predominantly a regional effect occurring in a limited time percentage of the year.

Rain and ice crystals in the propagation path of a radio signal can lead to polarization changes. Normally antennas are not able to compensate for such polarization change. Hence, there will be a polarization mismatch between the receiving antenna and the incident radio wave. Polarization mismatch result in reduced received signal strength and potential interference from a co-polar signal [21, 28]. Reduced signal strength caused by polarization mismatch is normally referred to as depolarization loss while co-polar signal interference is called cross-polarization interference. The severity of these two effects can be understood through the Cross-Polarization Discrimination (XPD).

The XPD indicates the ratio between the energy received in the transmitted polarization and that received in the orthogonal polarization. A large XPD means low depolarization loss and cross-polarization interference. It decrease with the frequency and depend on the rain intensity. A recommendation issued by ITU provides a procedure for calculation of XPD [22]. The procedure for the XPD calculations is based on rain attenuation predictions. In Table 6.7 estimated XPD values calculated from the 0.1% rain attenuation predictions in Tables 6.4, 6.5 and 6.6 are presented both for linear and circular polarization.

With linear polarization, the XPD is quite high, even in the K_a band for the most rain intensive 60° North case. Depolarization loss and cross-polarization interference are, therefore, assumed to have a negligible impact if linear polarization is used. The estimated values of XPD for circular polarization are

significantly lower. They are assumed high enough for the depolarization loss to be insignificant. However, it might be necessary to consider the cross-polarization interference in link budget calculations. Especially for high availability applications that require a communications link also in periods of heavy rain.

6.3.4 Other effects

There are also other propagation effects that can affect satellite communications. A number of effects are caused by the ionosphere, such as Faraday rotation, propagation delay, refraction, absorption, dispersion and scintillation. The troposphere can also cause scintillation as well as beam divergence and wave-front incoherence. However, for the frequencies and elevation angles relevant here these effects have a very limited impact compared to those discussed previously. As a result, they are assumed to be more or less insignificant for the system proposed and investigated here.

6.4 Discussion on frequency

Both a K_u and K_a band system will experience propagation impairments, with the K_u band being slightly better off than the K_a band. However, other considerations apart from the propagation properties must be taken into account. One such consideration is system compatibility with GEO based communications services. This is regarded as an important feature. It will allow users to roam between GEO coverage and the HEO based Arctic communications system, and creating truly global communications coverage. Users with a global operating area, such as many maritime and aeronautical users, would prefer an Arctic communications solution to be compatible with GEO as it would simplify their infrastructure needs. In this context, the ITU regulations come into play. According to them an Earth Station onboard Vessel (ESV) antenna must have a minimum diameter of 1.2 m. This can be reduced if a lower power is transmitted, but then the throughput will be reduced. Similar restrictions have not been put into place for the K_a band. Thus, smaller antennas can be deployed in a K_a band system than in a K_u band system without infringement of regulations.

The K_u band has the best propagation properties and is likely to support a higher availability than the K_a band. However, because of the higher frequency

and regulatory requirements the K_a band allow for smaller antennas than the K_u band. This is not necessarily a huge drawback for the K_u band since it already is in widespread use for maritime communications, and to some extent also for aeronautical communications. The K_a band is very interesting because of the antenna gain advantage over the K_u band. Another argument for the K_a band is the plans large satellite operators have for global K_a band coverage. Arctic K_a band coverage would also complement current and planned K_a band coverage of regional operators in Scandinavia, Canada and Russia.

In the following chapters, the advantages and disadvantages of both the K_u and K_a bands are highlighted with the help of link budgets and throughput calculations. That will make the differences more clear and show how antenna size affect performance and availability. Therefore, both the K_u and K_a bands have been used in the system definition process addressed in the following chapters.

Chapter 7

System architecture and payload design

The system architecture of a satellite communications system is important for the provision of its services. Network topology is closely linked to the payload configuration and how services can be provided. When designing a payload it is necessary to make numerous considerations and trade-offs. These are considerations such as antenna design, transmitting power, satellite handover and many more.

First in this chapter, the system architecture is discussed. Then satellite antenna solutions are considered for both the feeder links and user links. Satellite transmitting power and various losses are also given attention along with system noise temperature considerations for both the satellite and earth station side. A coding and modulation scheme that allow for the use of ACM is proposed. At the end of the chapter challenges regarding Doppler shift and satellite handover is presented, and possible solutions are proposed.

7.1 Network topology and payload configuration

Typically the network topology of a satellite communications system is either a mesh or a star topology. In a system with a mesh topology, all ground stations are able to communicate with each other via satellite. As a result, intra-system traffic needs only one satellite hop. A system with a star topology requires all communications to go through a central ground station, which distributes

the traffic and ensures all transmissions reach the intended recipient. Such a central ground station is usually referred to as a hub [7]. With all traffic channeled through a hub, intra-system traffic needs two satellite hops for end-to-end connectivity.

In a communications system based on a star topology, the satellites can have a conventional transparent payload configuration. Transparent communications satellites are often referred to as bent pipe satellites. A communications satellite with a transparent payload has a relative simple design that offer high reliability, as well as flexibility. Another advantage of transparent communications payloads are that they are service neutral. Hence, should user requirements and demand change after the satellite launch, it is possible to alter how the various services use the payload capacity. New services can also be added.

The main advantage of a mesh topology is that it enables single-hop connectivity between ground stations. This is possible with traffic routing directly on board the satellite, bypassing the central hub on the ground. Single-hop connectivity reduces signal delay significantly and saves satellite power since the traffic is transmitted from the satellite only once [31]. In satellites where the coverage is provided through only one antenna beam, single-hop connectivity is possible with a conventional transparent payload configuration. That is possible since all traffic is routed through the same antenna beam. Satellites with multiple spot beams will, on the other hand, require some form of routing mechanism to ensure that the traffic is transmitted in the right spot beam. Such traffic routing is possible both with a transparent and a regenerative payload configuration [7].

On board routing in a transparent payload, is achieved through cross coupling of antenna beams with different transponders. This is done by filtering the uplink frequency band in each spot beam into many sub-bands. Each of these sub-bands has its own transponder which is connected to a certain downlink beam. Thus, routing of traffic can be achieved by selection of the appropriate sub-band that corresponds to the downlink beam covering the recipient. For full connectivity, it is necessary for all uplink beams to have the same amount of filters and transponders as the number of downlink beams. In satellites with many spot beams the number of transponders required will then be high. Typically the required number of transponders grows with the squared number of spot beams. A satellite with many spot beams will then need a payload with many transponders, which results in a large mass and an excessive power consumption [7]. Figure 7.1 illustrates this concept of beam connectivity using a simple example with two antenna beams.

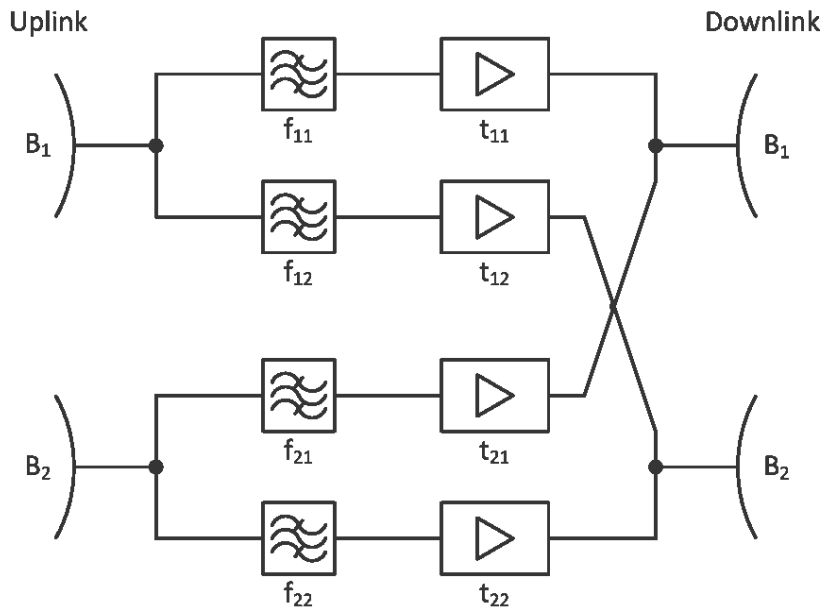

Figure 7.1: Illustration of beam connectivity which can allow mesh network topology on a multi-beam transparent payload.

Routing in a communications satellite with a regenerative payload and On Board Processing (OBP) is done in a completely different way. Key functions in a communications payload with OBP are demodulation, demultiplexing, error detection and correction, removal of routing and control information, multiplexing and modulation. These functions allow routing on packet level and rate conversion. That paves the way for different multiple access and multiplexing techniques on the uplink and downlink. Implementation of FDMA on the uplink allows continuous transmission by the earth stations. Time Division Multiplexing (TDM) on the downlink open up for Single Carrier Per Channel (SCPC) operation, which allows amplifiers in the satellite to work in saturation without generation intermodulation noise. Such a configuration will save power both in the satellite and the earth stations. Reception of a single TDM carrier generated in the satellite will also reduce the complexity and cost of the user terminals [7, 31].

Regenerative payloads may reduce the required E_b/N_o with up to 3 dB since the uplink noise is not amplified along with the signal on the downlink like in transparent payloads. Furthermore, a regenerative payload with OBP combined with an array antenna enables the possibility for implementation of dynamic beam-forming as well as dynamic, on-demand allocation of antenna gain and

coverage. These features provide the possibility for very flexible and efficient use of satellite capacity and resources [7, 31].

A disadvantage with a regenerative payload configuration is the high complexity. It will inevitably increase the cost and reduce the reliability. The need for fast computing circuitry in a regenerative payload drives the power consumption up. Possibly to the extent where other power savings are neutralized. The main drawback with a regenerative payload configuration is, however, the need for a predefined transmission format. This reduces interoperability as only a waveform compatible with the predefined format will be regenerated by the satellite. After launch, only limited changes to the transmission format can be done. Effectively the satellite and its payload is then locked to a set of services defined before launch. It is then very difficult to adapt to changes in traffic and service demand at a later stage, both in terms of volume and nature [7, 31].

In satellite communications systems where the bulk of the traffic is limited to the system, a mesh topology and regenerative payload configuration can be very advantageous. It increases the potential throughput capacity by greatly reducing the total traffic, and it cuts the signal delay by up to 50%. The downside is satellites that are more complex, less flexible and cost more.

Star topology and satellites with a transparent payload configuration are best suited for satellite systems with a small proportion of intra-system traffic. In such systems, the majority of the traffic pass through a hub on the way to or from the system. The remaining intra-system traffic, if any, will in such cases not justify the increased cost and complexity of a regenerative payload.

The traffic in an Arctic satellite communications system is assumed to be dominated by traffic originating or destined outside of the satellite system. There are uncertainties regarding the future development of the service requirements and demand in Arctic and high latitude areas. Those uncertainties apply both to services, applications, volume and coverage. Therefore, it is important to implement a system solution with a high degree of flexibility. Ensuring a system that can be adapted to the needs and requirements as they change and evolve. These factors all point in the direction of a communications network in a star topology, and satellites with a transparent payload configuration. If the system is designed with a low number of spot beams, it is an alternative to implement beam connectivity. That will allow limited mesh network topology capabilities for special applications, in addition to the regular star connectivity. Such a possibility should be considered in further studies, but it is not addressed here.

A system architecture based on a star network topology and satellites with a transparent payload configuration is assumed to be the best fit for an Arctic satellite communications system. It is currently expected to be the most cost effective, flexible and reliable alternative. Maximizing the use of conventional and well proven technology will reduce the risk in a project containing many unfamiliar aspects related to HEO satellite operation. How the spectrum and capacity are distributed among the services and applications offered by the system, can be changed at any time. Bent pipe satellites are dumb in the sense that they will receive, convert, amplify and retransmit any radio signal within the appropriate frequency band incident on the antenna. Changes and adaptations of technology, waveform, multiplexing and access method can, therefore, be done at any time during the satellite's operational life. Much uncertainty is tied to capacity and service requirements in future Arctic and high latitude regions, both in terms of volume and geographical development. A high degree of flexibility is paramount to ensure that an Arctic communications system can adapt to these requirements and ensure a safe and sustainable development of the Arctic region.

7.2 Satellite antenna technology

Antennas can be realized using different types of technology and solutions. Satellite broadband applications require directive antennas onboard the satellites to ensure adequate antenna gain. In satellite broadband communications, typically horn, reflector, lens and array antennas are employed onboard the satellites. The technologies differ in gain, sidelobe levels, efficiency, complexity, mass and volume [7]. As the satellites considered here are not going to be stationary, it is necessary to have a steerable antenna solution. A steerable antenna solution can be implemented for a reflector antenna, either through mechanical or electronically means. Use of reflector antenna technology is a conventional approach normally used for satellite communications.

Reflector antennas can create spot beams and shaped beams. A reflector antenna consists of a reflector which is illuminated by one or more feeder elements. Most reflector antennas are circular symmetric and parabolic. The feeder elements are either positioned at the focal point or in an offset position. Offset positioning of the feeder elements is used to avoid blocking of the reflector aperture. Shaped antenna beams are produced by small adjustments to the form of the reflector. Reflector antennas are relatively easy to produce, and they are reliable in operation.

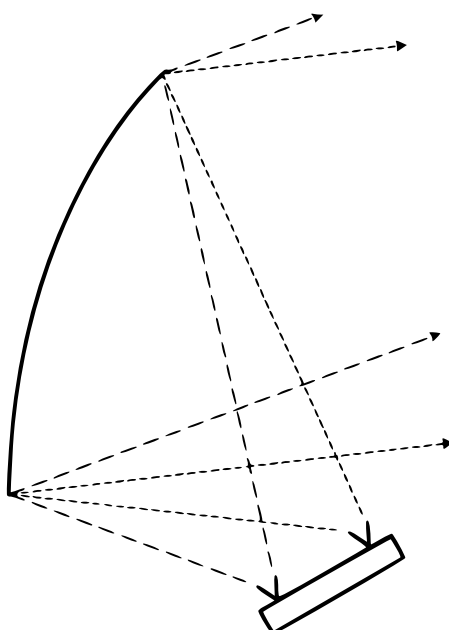

Figure 7.2: Illustration of an offset reflector antenna, and how feeder element position change the beam direction.

The pointing direction of a reflector antenna can be adjusted via telecommand if it is fitted with a mechanical steering device. Alternatively, the pointing direction can be controlled electronically if the reflector is illuminated by multiple feeder elements. Figure 7.2 illustrate how the position of the feeder element decides the direction of the beam. If the signal amplitude is distributed between two feeder elements, the amplitude center will act as a feeder link position. Thus, by adjusting the amplitude distribution between two feeder elements an antenna beam can be controlled to point in the same direction as any feeder element positioned on the line between the two feeder elements. This can be expanded into two dimensions with a small array of four feeder elements. Dynamic adjustment of the amplitude distribution between four feeder elements will allow dynamic modification of antenna pointing in both north-south and east-west direction.

An offset reflector antenna with a small array of feed elements has interesting properties. It is a well known and proven technology with a high reliability. Only four amplitude controlled feed elements are required in an array for full beam pointing control. Therefore, the feeding network will have limited complexity and reduced ohmic losses. Accurate beam forming is not possible after

launch of satellite, but reflector antennas have gain performance and acceptable sidelobe levels. Thus, offset reflector antennas with small arrays of feed elements should be used onboard the satellites. It is assumed to be appropriate for both the feeder link and the user link.

7.3 Feeder link antenna

A feeder link is a communications link between a gateway or central hub and a satellite. Gateway stations will have different properties than other earth stations. Larger and more powerful terminal equipment results in a different link design than for user terminals. Gateway stations are extremely important for the flow of traffic in satellite communications system with a star topology. Therefore, feeder links must be more reliable and have a higher availability than a regular user links. To ensure this, it is appropriate to use different antennas on the satellite for feeder and user links. Because of the frequency difference it might also be wise to have separate antennas on the uplink and downlink as well, especially when using the K_a band.

The 12H3S3P constellation proposed for this system will have satellites operative in two apogee locations at the same time. These two satellites should be served by different gateway earth stations. Good locations for such gateway stations would be Norway, Sweden and Finland in Europe and Alaska and northern Canada in America. For the European feeder link coverage, it is assumed adequate with a 3 dB beamwidth in the vicinity of 1° . With the satellite at apogee, such a beamwidth will provide coverage of an area like the southern part of Norway. Multiple gateway or hub earth stations can operate within that coverage, and it will give ample opportunity for a redundant and diversified gateway architecture. In Alaska and northern Canada the distance between potential gateway earth station locations is longer. Therefore, a wider feeder link coverage might be of interest there. When the satellite is at apogee, the whole Alaskan mainland can be covered with a 2° beam. This is assumed to be a more appropriate coverage for the North American feeder link. It is undesirable with separate feeder link antennas on the satellites for the two apogee locations. Thus, a compromise is necessary.

It is assumed that a compromise between the appropriate feeder link beamwidth for North America and Europe imply a beamwidth between 1° and 2° . In the K_u band, the beamwidth will typically be between 1° and 2° in both link directions if the antenna diameter is in the range from 0.95 m to 1.50 m. For

Table 7.1: Beamwidth and gain calculated for the feeder link antenna onboard the satellites. Uplink and downlink gain of both K_u and K_a are shown. An aperture efficiency, η , of 65 % have been assumed.

Frequency [GHz]	Antenna diameter [m]	Beamwidth [°]	Antenna gain [dB]
11	1.20	1.59	40.9
14	1.20	1.25	43.0
20	0.65	1.61	40.8
29	0.65	1.11	44.0

the K_a band, that range goes from 0.52 m to 0.72 m. Hence, it is assumed feasible to use the same antenna in both feeder link directions. Based on these findings the diameter of the feeder link antenna onboard the satellites is set to 1.20 m for the K_u band, and to 0.65 m for the K_a band. The resulting beamwidths are presented in Table 7.1. Figure 7.3 and 7.4 illustrate how the antennas for the two frequency bands can provide coverage of an area. In both figures, the inner contour is the uplink coverage, and the outer contour is the downlink coverage. The two coverage examples assume a satellite at apogee positioned 15° East. It is assumed that the feeder link antenna coverage can be regarded as good for both frequency bands.

Reflector antennas onboard satellites typically have aperture efficiency around 65 % to 70 % [32]. A conservative figure of 65 % is used here. Table 7.1 show the maximum antenna gain calculated for the two frequency band alternatives. The results are regarded as good, and should allow the feeder links to support the necessary capacity. The gain can be increased further by enlarging the antennas, but that results in a more narrow beam and reduced geographical coverage. Coverage examples illustrated in Figure 7.3 and 7.4 indicate that the suggested antennas provide ample coverage. Redundancy and diversity requirements, as well as potential secondary hubs, might be possible to accommodate inside a smaller coverage area. If this is the case, larger antennas with a higher gain can be employed onboard the satellites. For this study, the antenna properties listed in Table 7.1 are used.

7.4 User link antenna

One of the key elements of a user link antenna solution is the coverage it provides. The 12H3S3P constellation will have two satellites visible from the

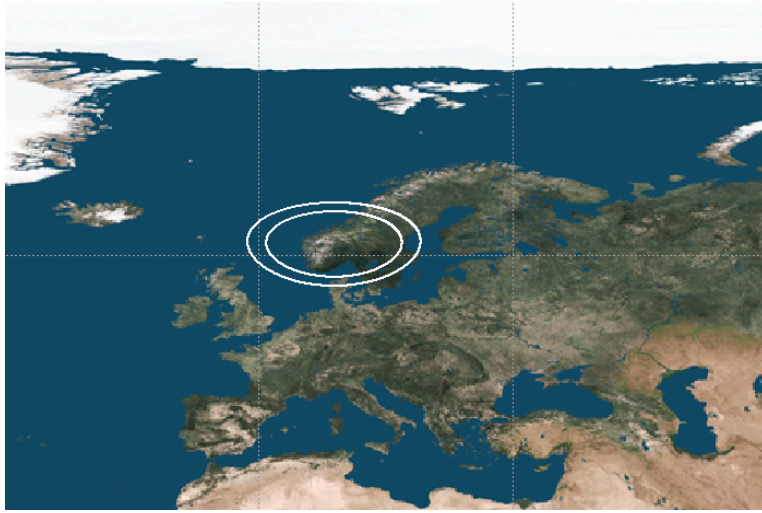

Figure 7.3: Example of coverage possible with a 1.20 m K_u band feeder link antenna onboard the satellites. The inner contour show the 14 GHz uplink 3 dB beamwidth, while the outer contour show the 11 GHz downlink 3 dB beamwidth. The illustration assumes a satellite at apogee positioned 15° East.

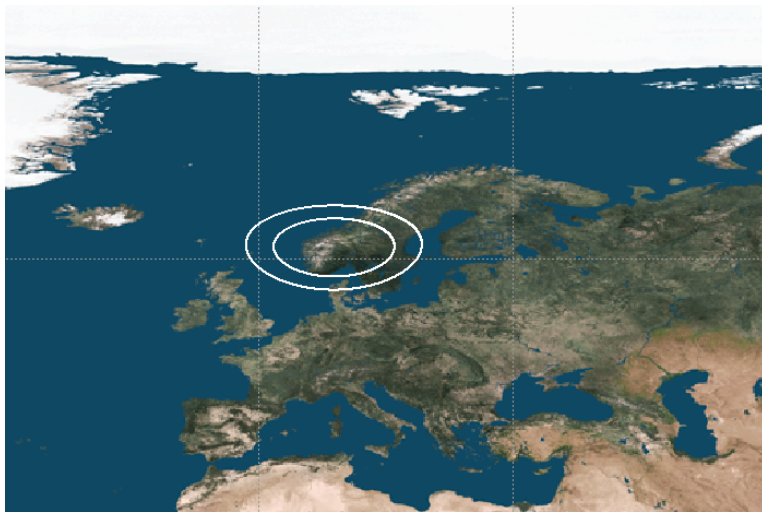

Figure 7.4: Example of coverage possible with a 0.65 m K_a band feeder link antenna onboard the satellites. The inner contour is for the 29 GHz uplink, while the outer contour is for the 20 GHz downlink. The illustration assumes a satellite at apogee positioned 15° East.

required and extended coverage area at all times. It is natural to divide the traffic between these two satellites. However, to take advantage of redundancy and load sharing capabilities dual coverage provide, both satellites must support coverage of the whole area. A flexible payload and antenna solution will allow the capacity and power to be assigned to areas with traffic. How the two active satellites divide the coverage area and traffic between them can then be dynamically adapted according to demand. Both satellites can also provide capacity to the same areas and regions if the traffic volume is higher than one satellite can support alone.

Another aspect that must be considered during the design of the user link antenna solution onboard the satellites is the antenna gain. A sufficiently high Effective Isotropic Radiated Power (EIRP) is necessary for support of the required services. The EIRP can be broken down into two parts. Those two are the signal power delivered by the communications payload and the antenna gain. Thus, selection of an antenna solution with a relatively low antenna gain will require a correspondingly more powerful communications payload. A high gain antenna solution will ease the payload power requirements. It is possible to lower the EIRP requirements of the space segment through high capability requirements on the earth stations and user terminals. However, the intention to employ user terminals compatible with GEO systems limits the design space and capabilities of the ground segment.

Current and planned GEO communications satellites, provide peak EIRP values in the 50 dB W to 55 dB W range at K_u band and in the 55 dB W to 60 dB W at K_a . The HEO satellites in the suggested 12H3S3P constellation, will operate with a distance towards the users which is in the same order of magnitude as for GEO satellites. Thus, compatibility and roaming opportunities indicate that an Arctic satellite communications system should target the same EIRP values.

The necessary coverage can be realized with one wide antenna beam or a multiple spot beam antenna solution. Both a regional wide beam antenna solution and a spot beam antenna solution, have advantages and disadvantages. Three alternatives are given consideration here and are discussed in the following sections. Those three are a single wide beam antenna solution, a quadruple spot beam antenna solution and a seven spot beam antenna solution.

7.4.1 Single wide beam antenna solution

A regional antenna beam can provide the desired coverage in a straightforward manner. It would allow the satellite capacity to be available inside the whole



Figure 7.5: Coverage realized by a satellite at apogee with a 9° antenna beamwidth. The black circle show 60° northern latitude, and the white contour indicate the 3 dB beamwidth of a 9° antenna beam.

coverage area in a very flexible manner. The wide beamwidth necessary to cover the required coverage area as well as the extended coverage area will lead to a relatively low antenna gain. To reach the target EIRP values the communication payload will then have to be comparatively more powerful. The alternative is to reduce the service requirements or increase the capabilities elsewhere in the system in order to close the link budget.

From apogee, a satellite will cover the Arctic and high latitude areas down to 60° North with a 3 dB antenna beamwidth of approximately 9° . Figure 7.5 illustrate how this coverage can be realized. The black circle indicate 60° northern latitude while the white contour is the 3 dB beamwidth of a 9° antenna beam. Notice that there will be some spillover coverage when a circular beam is used since the satellite are not positioned straight above the North Pole.

The user link coverage can be realized with the same antenna onboard the satellites for both uplink and downlink. However, because of the difference in frequency the area covered within the 3 dB beamwidth will not be the same. At

the lower downlink frequency, the coverage is greater with the same antenna dimensions. A greater coverage also indicates a lower antenna gain. With one antenna onboard the satellites used both for uplink and downlink, the narrower uplink beam dictates the maximum antenna diameter. The 9° beamwidth can be realized at 14 GHz with an antenna diameter (aperture) of only 16.7 cm. If 65% aperture efficiency is assumed, such an antenna provides an uplink gain of 25.9 dB and a downlink gain of 23.8 dB in the K_u band. At 29 GHz, the antenna diameter shrinks to 8 cm. This leads to a K_a band uplink and downlink antenna gain of 25.9 dB and 22.7 dB respectively.

Separate user link antennas onboard the satellite for uplink and downlink would not change the uplink parameters, only the downlink antenna parameters. Downlink antenna diameter can then be increased in order to match the 9° beamwidth coverage. The result would be a downlink antenna diameter of 21.2 cm at K_u band and 11.7 cm at K_a band. Downlink antenna gain would increase to 25.9 dB at both frequency bands. The small antenna dimensions will simplify accommodation of separate antennas onboard the satellites and allow 2 dB to 3 dB higher gain on the downlink. Both uplink and downlink user antenna would then provide coverage like the one illustrated by the white contour in Figure 7.5.

A downlink antenna gain of 25.9 dB is a relatively low value. In order to reach the EIRP target discussed above, the satellite payload must then provide an output power level in the 25 dBW to 30 dBW range at K_u band and in the 30 dBW to 35 dBW range at K_a band. That is unrealistically high output power levels. In the K_u and K_a bands, high performing Travelling Wave Tube Amplifiers (TWTAs) onboard satellites typically provide a maximum output power of 20 dBW to 22 dBW [7]. This leaves a performance gap that can only be met by increased capabilities at the earth stations, such as larger user terminal antennas. A requirement for larger earth station antennas would limit a GEO communications system user's possibilities for roaming into the Arctic communications system. Although HEO based users with larger antennas would be able to roam with GEO systems, this is assumed to have a negative impact on the market potential of an Arctic communications system.

7.4.2 Quadruple spot beam antenna solution

Coverage of the required area can also be provided by a quadruple spot beam antenna solution. The four spot beams would have a narrower beamwidth than the single wide beam antenna solution. Hence, the antenna gain is larger

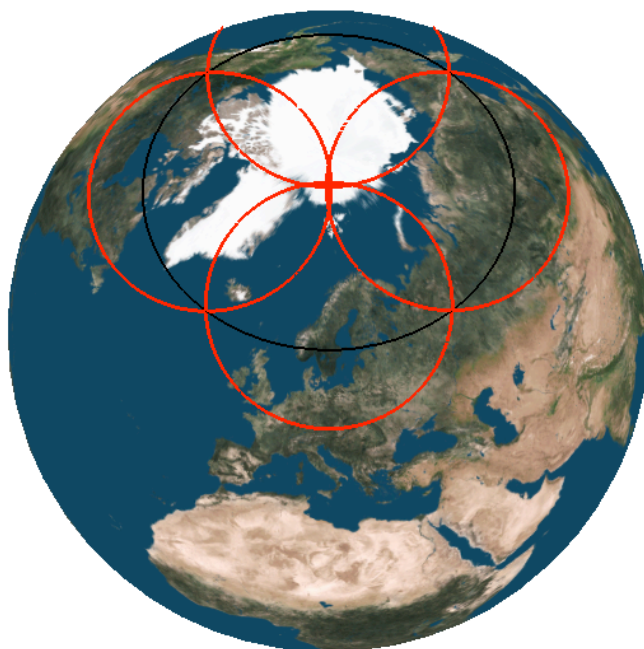

Figure 7.6: Coverage realized by a satellite at apogee with quadruple spot beam antenna solution. The black circle show 60° northern latitude, and the red contours indicate the 3 dB beamwidth of the four 5.9° antenna beams.

with a quadruple spot beam antenna solution. As a result, the payload output power requirements necessary to reach the targeted EIRP levels are reduced.

With circular spot beams, the 3 dB beamwidth of the four beams must be 5.9° for full coverage of the required and extended coverage area. Figure 7.6 indicate the spot beam pattern for a satellite at apogee. The red circles illustrate the 3 dB beamwidth of the four spot beams, and the black circle show 60° North. As Figure 7.6 shows, there will be even more spillover coverage with a quadruple spot beam antenna solution compared to the single beam alternative considered above.

At 14 GHz, an antenna diameter of 25.4 cm is necessary to realize a beamwidth of 5.9°. Assuming 65% aperture efficiency, the gain of such an antenna would be about 29.6 dB. The same antenna used for the 11 GHz K_u band downlink would provide a gain of 27.5 dB. At the K_a band uplink frequency of 29 GHz, the beamwidth of 5.9° can be realized with an antenna diameter of 12.3 cm. With the same antenna used for both uplink and downlink, it would ensure a gain of 29.6 dB and 26.3 dB in the two directions respectively.

Also for the quadruple spot beam alternative the antenna dimensions should not be a hindrance for separate uplink and downlink antennas. A downlink antenna with a 5.9° beamwidth would be slightly larger than the corresponding uplink antenna, but not by much. The K_u band downlink antenna would have a diameter of 32.3 cm while the K_a band downlink antenna diameter would be 17.8 cm. Separate antennas onboard the satellites for user uplink and downlink increases the downlink antenna gain with approximately 2 dB to 3 dB. Additional gain increase might be possible if the antenna beams are shaped to reduce the spillover coverage.

With an antenna gain of 29.6 dB, the targeted EIRP levels can be reached with payload output power in the 20 dB W to 25 dB W range for the K_u band and in the 25 dB W to 30 dB W range for the K_a band. Based on the possible TWTA performance discussed in the previous section, it is assumed to be realistic with a quadruple spot beam antenna solution for the K_u band. In the K_a band, the quadruple spot beam antenna solution is not assumed to be a good alternative because of the higher EIRP level targeted. A reduced EIRP level would require more capable user terminals for support of the same services as provided by current and planned GEO systems.

For service provision via a multiple spot beam solution, the available frequency band must be split between the spot beams. The antenna beams in the quadruple spot beam alternative will be overlapping each other. Thus, frequency reuse is not possible. Division of the available frequency band between the spot beams introduces challenges. A satellite payload that support dynamic reallocation of frequencies and capacity between spot beams according to traffic demand will mitigate these challenges for broadband and backhaul services. Combined with steerable spot beams such flexibility allows for effective utilization of satellite resources. A spot beam solution will, on the other hand, affect the broadcasting service adversely. With the coverage area split between spot beams, broadcast signals may need to be transmitted in all spot beams at different frequencies for full coverage. This greatly increases the resources required for support of broadcast services. However, it does allow a regional broadcast service to be transmitted to limited parts of the coverage area.

7.4.3 Seven spot beam antenna solution

An antenna solution with seven spot beams providing the necessary coverage reduces the necessary beamwidth further from the 5.9° beamwidth of the quadruple spot beam alternative. The corresponding increase in antenna gain

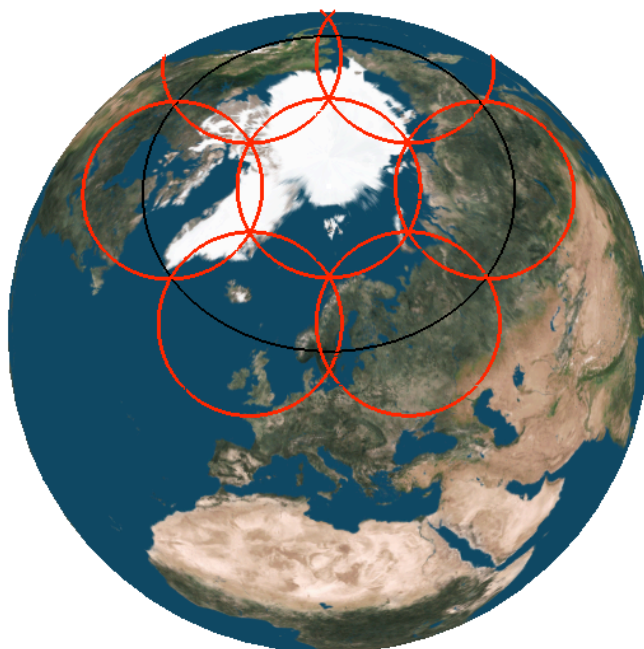

Figure 7.7: Coverage realized by a satellite at apogee with a seven spot beam antenna solution. The black circle show 60° northern latitude, and the red contours indicate the 3 dB beamwidth of the seven 4.4° antenna beams.

can potentially reduce the output power required from the satellite payload even more. A seven spot beam antenna solution would nominally provide the necessary coverage through a cell structure. This cell structure consists of a center spot beam encircled by the remaining six spot beams. Full coverage of the extended coverage area can then be achieved if the spot beams have a 3 dB beamwidth of 4.4° . The spot beam configuration is illustrated in Figure 7.7, where the red contours indicate the 3 dB beamwidths and the black circle denote 60° northern latitude. Substantial spillover coverage is also the case for the seven spot beam antenna solution, as confirmed in Figure 7.7.

The same illumination coefficient and aperture efficiency as used previously is assumed when calculating the antenna parameters. A beamwidth of 4.4° for the K_u band uplink frequency can be realized with an antenna diameter of 34.1 cm. Such an antenna would have an antenna gain of 32.1 dB for the uplink and 30.0 dB for the downlink. With the K_a band uplink frequency an antenna diameter of 16.4 cm produces a 4.4° beamwidth. For the 29 GHz uplink frequency that equates to an antenna gain of 32.1 dB. On the 20 GHz downlink frequency such an antenna has a gain of 28.9 dB.

Small antenna dimensions suggest that separate uplink and downlink antennas onboard the satellites are implementable. A 43.4 cm antenna would provide the desired 4.4° beamwidth for the 11 GHz K_u band downlink. For the K_a band downlink, the antenna diameter would need to be 23.8 cm in order to produce the same beamwidth. Separate uplink and downlink antennas will increase the downlink antenna gain with 2.1 dB in the K_u band and 3.2 dB in the K_a band. This gain increase is assumed to justify accommodation of separate user uplink and downlink antennas onboard the satellites.

The substantial spillover coverage of the proposed seven spot beam configuration indicated in Figure 7.7, suggests potential for additional antenna gain increase through the employment of shaped beams. Shaping of antenna beams to fit better with the desired coverage area is not considered further in this study. However, the potential for higher antenna gain should be addressed in future studies refining the system design. Possible improved service performance and additional link margins will always be valuable.

Satellite payload output power between 17 dB and 22 dB for K_u band operations and between 22 dB and 27 dB for K_a band operations, is necessary to meet the targeted EIRP values when the antenna gain is 32.1 dB. This is comfortable operational requirements for K_u band satellite transponders, and it can be implemented with margins. For the K_a band the power requirement is still a stretch, but it should be feasible to design a satellite payload providing EIRP values close to the targeted level.

With three more beams compared to the quadruple spot beam alternative, the seven spot beam alternative require further splitting of the available frequency band. However, with a flexible payload design this should not introduce any significant problems for broadband and backhaul services. A payload design ensuring the desired flexibility will increase in complexity with a growing number of spot beams, but it is assumed that a satellite payload supporting the suggested seven beam solution will not be too complex.

Seven spot beams do pose a challenge for broadcasting services. Provision of a broadcasting service across the whole coverage area require the same content to be transmitted seven times. As a result, support of a broadcasting service will lay a heavy claim on satellite resources. It is well known that a cell structured coverage is unsuitable for efficient broadcasting services. Possible solutions are either limiting broadcasting to regional services or the addition of a separate wide beam broadcasting antenna on the satellites.

Frequency reuse is deemed not possible for the seven spot beam antenna

solution also. The discrimination between spot beams on opposite sides of the central spot beam is estimated to be less than 15 dB. Therefore, reuse of frequencies would result in an interference level which is unacceptable. Note that frequency reuse is deemed to be unnecessary as the expected capacity demand is supportable with available frequency resources.

7.5 Coverage area variation

The satellites in the suggested 12H3S3P constellation are not stationary. Both the position of the sub satellite point and satellite altitude will be constantly changing, also during the periods the satellites are active. As a result, the field of view observed from the satellites is not constant. Position of the coverage area relative to the nadir angle will vary as the satellites move from the incoming handover point to the outgoing handover point via apogee. The combination of orbital geometry and earth's rotation about its axis give a rotation of the coverage area around nadir. These effects are illustrated in Figure 7.8.

Steerable antenna beams are an advantage in handling these field of view variations. It will allow antenna beams to move with the rotation and stay pointed towards a fixed position on the earth. Such behavior significantly reduce the amount of traffic that need handover between antenna beams. Without steerable antenna beams the rotation around nadir must be countered with attitude maneuvers. Such attitude maneuvers are not straight forward as they require complicated coordination to ensure the solar panels have an appropriate angle towards the sun.

The antenna solution suggested here implement beam steering through virtual adjustment of the feeder element position. A beam created to point a certain angle away from boresight of the reflector antenna will have a reduced gain. The gain reduction is due to the smaller projected aperture area available in the direction of the beam. Assuming the boresight of the antenna is in the nadir direction the maximum reduction in projected aperture area is limited for all the three antenna solutions discussed above. In terms of gain reduction, it amounts to less than 0.1 dB. Thus, reduced gain because of smaller projected aperture area is assumed to be negligible for the suggested user link antenna alternatives.

Because of the variation in satellite altitude during the active period the area covered within the 3 dB beamwidth will change over time. A given 3 dB



(a) Incoming handover

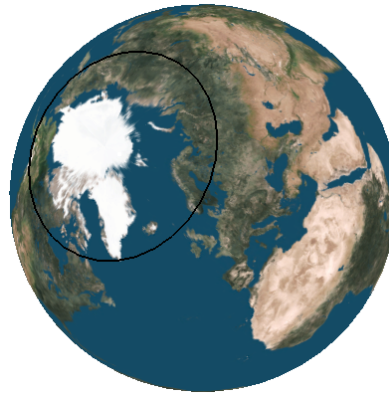

(b) Halfway to apogee

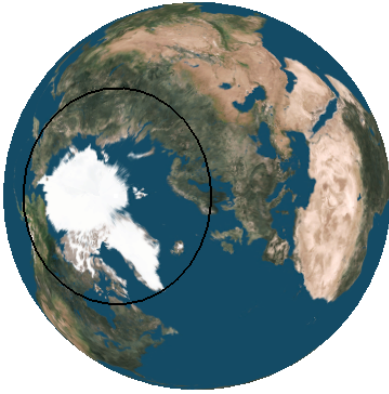

(c) Apogee

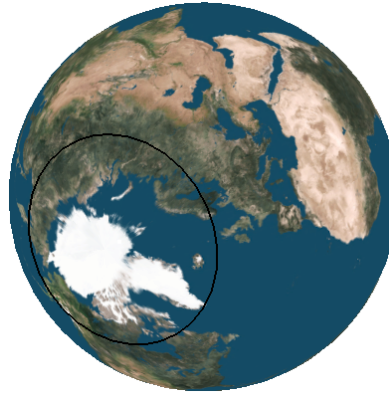

(d) Halfway to handover

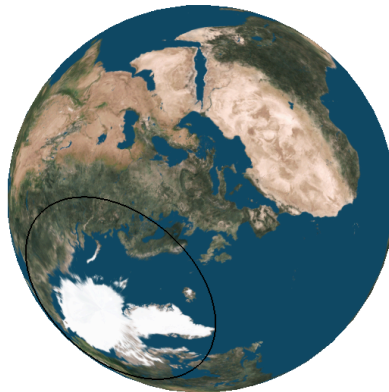

(e) Outgoing handover

Figure 7.8: Change in field of view from a satellites during an active period. The illustration is based on a 12H3S3P satellite with an apogee located at 15° East. The orbital plane is oriented upwards and orthogonal to the paper plane.

beamwidth cover the largest area when at apogee. The lower altitude at handover results in a smaller area covered within the 3 dB beamwidth. However, a radio signal sent from a satellite at a lower altitude have a lower free space loss. This can be utilized to compensate for reduced antenna gain and increase the area covered by an antenna beam.

Within the extended coverage area down to 60° northern latitude, the free space loss at handover is between 3.3 dB and 4.3 dB lower than at apogee. The exact difference depends on the position. Earth stations positioned close to the apogee sub satellite point will experience larger free space loss variations than other stations. An earth station positioned at 60° North at the longitude of the opposite apogee location will have the lowest free space loss variation. Between apogee and handover the variation is 3.3 dB. Coverage of that area is primarily to ensure redundancy, and because of spillover coverage effects it is far from the edge of beam coverage. For these reasons, it is more interesting to assess the antenna beam coverage based on the situation at 60° North and in the middle of the two apogee positions longitude wise. At that position, the difference between the free space loss at apogee and handover is 3.7 dB. Thus, the 6.7 dB beam contour with a satellite at the handover point will produce approximately the same flux density on the ground as the 3 dB beam contour with the satellite at apogee.

The change in coverage for the single beam solution is exemplified by the two illustrations in Figure 7.9. In the illustration to the left, the green contour indicates the 6.7 dB beamwidth with the satellite at the handover point. The white contour in the illustration to the right show the 3 dB beamwidth with the satellite at apogee. It is evident that the coverage is very similar. Unfortunately for the single beam antenna solution, it is not able to include the whole area above 60° North within the 6.7 dB beamwidth when the satellites are at handover. There are two small slices of the extended coverage area between the two apogee locations that are outside the 6.7 dB beamwidth. In Figure 7.9a, these two areas can be observed as those outside the green contour, but inside the black circle denoting 60° North.

A similar example of the coverage variation for the quadruple beam antenna solution is given in Figure 7.10. In the illustration to the left, the coverage situation at handover is shown, and the illustration to the right show the coverage situation at apogee. The green contours denote the 6.7 dB beamwidths, and the red contours denote the 3 dB beamwidths. Inside the extended coverage area, the four spot beams will cover the same area as they do at apogee. At handover, the overlap between the spot beams are also more extensive than at

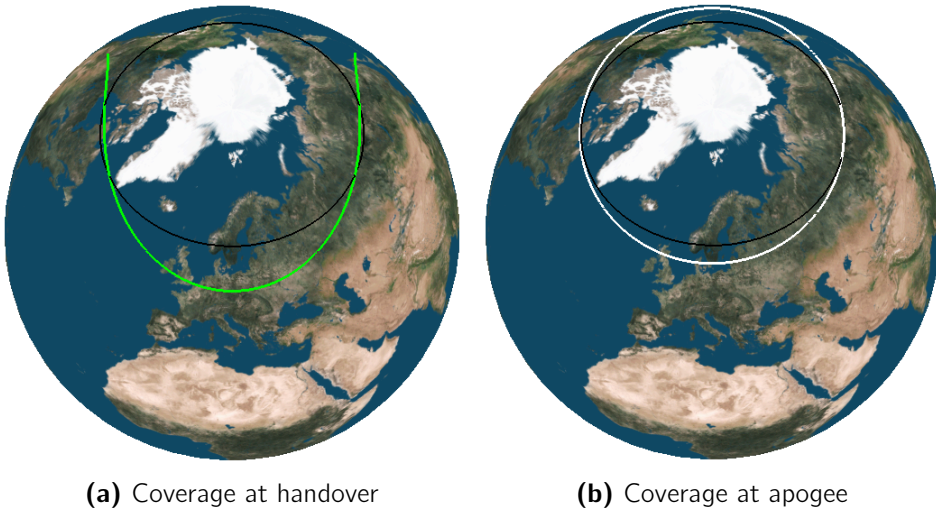

Figure 7.9: Illustration of change in coverage for the single beam antenna solution. In (a) the green contour indicate where the antenna gain is 6.7 dB lower than at beam center with the satellite at the handover point. The white contour in (b) indicate the area covered within the 3 dB beamwidth with the satellite at apogee, and is the same illustration as shown in Figure 7.5.

apogee. When the satellite is at apogee, the four spot beam antenna solution will also cover large areas outside the extended coverage area. This additional coverage is more limited in the handover coverage example shown in 7.10a, but the extensive overlap between the beams will allow the additional coverage to be increased if that is desirable.

The coverage variation between handover and apogee for the seven spot beam antenna solution is illustrated in Figure 7.11. Again, the situation at handover is indicated on the left with green contours denoting the 6.7 dB beamwidths, and the situation at apogee is indicated on the right with red contours denoting the 3 dB beamwidths. The whole extended coverage area is covered when a satellite is at handover, and an earth station will experience similar flux densities as with a satellite around apogee. Overlap between the spot beams is extensive above 60° North also for the seven spot beam antenna alternative. Additional coverage below 60° North is limited around handover, but the overlap between the spot beams make it possible to increase the additional coverage.

These considerations indicate that variations in the free space loss will compensate for variations in antenna beam coverage. The area within the 3 dB

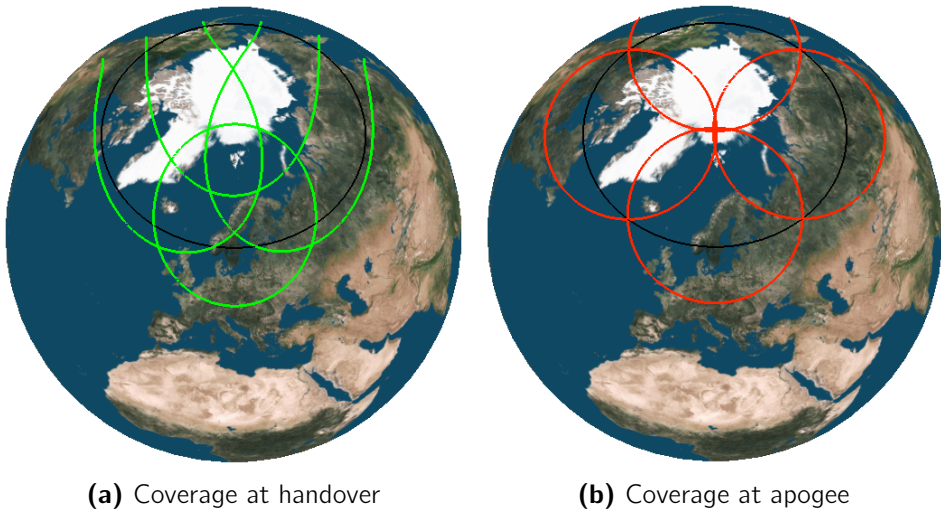

Figure 7.10: Illustration of change in coverage for the quadruple spot beam antenna solution. In (a) the green contours indicate where the antenna gain are 6.7 dB lower than at beam center with the satellite at the handover point. The red contours in (b) indicate the area covered within the 3 dB beamwidths with the satellite at apogee, and is the same illustration as shown in Figure 7.6.

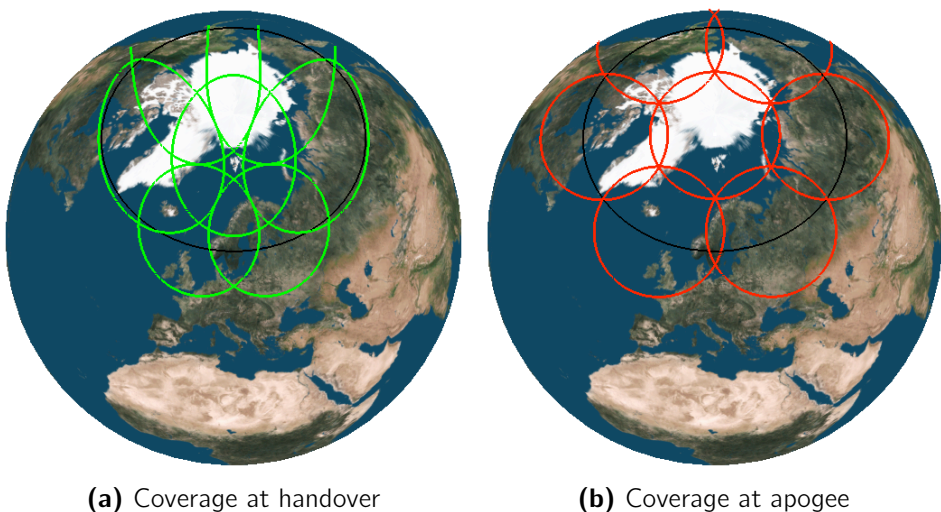

Figure 7.11: Illustration of change in coverage for the seven spot beam antenna solution. In (a) the green contours indicate where the antenna gain are 6.7 dB lower than at beam center with the satellite at the handover point. The red contours in (b) indicate the area covered within the 3 dB beamwidths with the satellite at apogee, and is the same illustration as shown in Figure 7.7.

antenna beamwidth of a satellite at apogee is similar to the area covered by the 6.7 dB antenna beamwidth of a satellite around the point of handover. This difference in antenna gain is comparable to the reduction in free space loss. Thus, it seems appropriate to assume that the satellites will provide a consistent coverage with a fairly stable signal strength environment at the spot beam edges. Furthermore, it can be concluded that link budget calculations based on a situation where a satellite is around apogee also is valid for satellites at handover and in the rest of the active part of the satellite orbit.

7.6 Satellite antenna configuration

Of the three user link antenna alternatives, the single beam antenna solution provides the lowest antenna gain. As a result, a single beam antenna solution will require the satellite payloads to be more powerful, or the earth stations more capable, in order to support services at the same level as antenna solutions with a higher gain. The advantage of a single beam alternative is its inherent simplicity. It provides a high degree of flexibility for the utilization of satellite resources. Capacity can be dynamically moved between services and geographic areas according to demand and requirements with only a minimum of reconfiguration necessary. In the previous section it was found, as shown in Figure 7.9, that the suggested single beam antenna solution are not able to provide a stable coverage of the whole extended coverage area. The areas with reduced coverage around satellite handover are very small, but it does highlight the limited antenna gain provided by the single beam antenna alternative. In sum, these considerations suggest that one of the two spot beam antenna alternatives would be more appropriate to implement.

In the following discussion, it is important to note that the user link antenna alternatives are designed based on beamwidths able to provide the necessary coverage. Spot beams with the appropriate beamwidths are created with different antenna dimensions for the two frequency bands. Therefore, the suggested user link antenna solutions have the same antenna gain in both frequency bands. Difference in performance levels between the two frequency bands stems from the higher EIRP levels targeted for the K_a band, typically up to 5 dB higher. The disparity in the EIRP target levels for the two frequency bands is inherited from current and planned GEO based satellite communications systems.

The higher antenna gain of the quadruple spot beam antenna solution relieves

the satellite payload requirements. A K_u band system will be able to support services at a performance level comparable to that of GEO satellites. For the K_a band, the situation is different. Existing and planned K_a band based GEO systems provide higher EIRP values than the K_u band systems. Thus, the antenna gain of the quadruple spot beam alternative is not adequate for support of GEO level services in the K_a band. If the K_a band is selected in combination with the quadruple spot beam antenna alternative, GEO performance levels can only be supported with earth stations and user terminals that are more capable than their GEO system counterparts.

A user link antenna solution onboard the satellites with seven spot beams covering the area above 60° North will have a higher antenna gain. As a result, a K_u band based system can provide the desired performance with comfortable margins. A K_a band based system supporting appropriate service levels can also be realized with a seven spot beam antenna solution. However, with the K_a band it will likely be necessary to have a more powerful satellite payload.

Both of the two antenna solutions are believed to be equally flexible in terms of capacity utilization and service provisions. They will, however, because of the division of the coverage area by the spot beams not be able to provide a pan-Arctic broadcasting service in an efficient manner. A spot beam coverage without frequency reuse requires TV channels and content bound for the whole coverage area to be transmitted on separate frequencies in all the spot beams. That ties up a lot of satellite resources and reduces the total available capacity. Based on these considerations it seems that the quadruple spot beam antenna solution is desirable from a broadcasting service provider's point of view. However, it is assumed that a substantial part of the broadcasting content will have a mostly regional interest. This content will not require pan-Arctic distribution. Thus, it reduces the inefficiencies of the spot beam coverage. With a careful consideration to geographic areas covered by different spot beams, it should be possible to optimize the coverage for regional services. Such an optimization would further limit the need for multi beam transmission of TV channels and other content.

The implementation of a seven spot beam antenna solution is not likely to be significantly more complex than a quadruple spot beam antenna solution. In both alternatives, the spot beams can be realized with two reflector antennas, one for the user uplink and one for the user downlink. With no frequency reuse, it is possible to create the necessary number of beams with one feeder element array per reflector. A seven spot beam antenna solution will need a

Table 7.2: Beamwidth, gain and antenna diameter calculated for the seven spot beam antenna solution chosen for the user link onboard the satellites. The parameters of both K_u and K_a are shown. An aperture efficiency, η , of 65% has been assumed.

Frequency [GHz]	Beamwidth [°]	Antenna diameter [cm]	Antenna gain [dB]
11	4.4	43.4	32.1
14	4.4	34.1	32.1
20	4.4	23.8	32.1
29	4.4	16.4	32.1

larger feeder network than a quadruple spot beam solution. That is necessary for the increased number of spot beams. Design of a larger feeder network is assumed to be a matter of scaling the payload correctly, and not adding any additional significant complexity.

The seven spot beam antenna solution has been selected for implementation on board the satellites for the user link. It will provide a higher antenna gain which allow for better services with higher availability and reliability. Furthermore, it is possible to reduce the payload power requirements which will decrease satellite costs. The key user link antenna parameters are summarized in Table 7.2 for uplink and downlink of both the K_u and K_a bands.

7.7 Satellite transmitting power

Possible transponder power is technology dependent. In general there are two alternative solutions, Solid State Power Amplifier (SSPA) and Travelling Wave Tube Amplifiers (TWTA). They have different advantages and are typically not used for the same applications. Transparent K_u and K_a band communications payloads typically need high output power levels, which only TWTA can provide. TWTA with saturation power in the range from 20 W to 250 W is possible. The efficiency of TWTA can typically be expected to be between 60% and 75% for commercial satellite communications applications. Linearity is an issue for TWTA technology. When operating at saturation in multi-carrier mode, the carrier to intermodulation noise ratio of a TWTA typically is only 10 dB to 12 dB [7]. With output back-off in the area of 3 dB to 4 dB and utilization of appropriate linearization techniques, this ratio can be increased to about 30 dB.

The EIRP levels suggested in section 7.4 indicate a need for a high power transponder. It is assumed, that space qualified TWTA solutions for operation in the K_u or K_a bands providing saturated output power levels between 150 W and 250 W are available. A DC to RF power conversion efficiency of about 75 % results in a transponder power consumption between 200 W and 335 W for such a transponder. For multi carrier operation, it is appropriate to apply an output back-off of 3 dB to 4 dB. That will ensure that the carrier to intermodulation noise ratio is adequately high. As a result, maximum output power is expected to be between 60 W and 100 W.

Combined with the 32.1 dB user link antenna gain applicable to the seven spot beam antenna solution, such transponder output power values indicate a possible EIRP between 49.8 dB W and 52.1 dB W. This is in the lower part of the targeted EIRP range for the K_u band, but below the targeted EIRP range for the K_a band. Thus, under these conditions, and with multi-carrier operation on the user downlink, TWTA transponders providing a saturated output power close to 250 W are necessary. Transponder power requirements of this magnitude will limit the design options for the communications payload. Therefore, alternatives that can reduce the power requirements have been explored.

One good option is to employ TDM on the forward link. With TDM, the traffic from the central hub to different users is put into time slots on a wide carrier. If the carrier is wide enough to fill a transponder, it can operate in single carrier mode. Transponders handling only a single carrier do not generate intermodulation products and can, therefore, operate in saturation. Removing the output back-off, this allows for a 4 dB improvement. For the K_u band alternative, an EIRP of 50 dB W can be achieved using a TWTA with a saturated output power level of slightly more than 60 W. A 100 W transponder will then provide an EIRP level in the middle of the targeted range. Combined with the user link antenna gain, an output power of 100 W, or 20 dB W, results in a K_u band EIRP of 52.1 dB W. Single carrier operation in the K_a band requires a saturated output power of approximately 200 W, or 23 dB W, to support an EIRP of 55.1 dB W for the user link.

The same types of transponders can also be used for the feeder downlink. On the return link, it might be desirable to use a form of Frequency Division Multiplexing (FDM) instead of TDM. FDM on the return link can make the system design less complex as the need for accurate time slot synchronization is removed. This, of course, results in multi-carrier operation of the transponders on the return link. A 4 dB output back-off is then needed to limit intermod-

Table 7.3: Summary of transmit power for the user and feeder downlink of both the K_u and K_a band case.

Frequency [GHz]	User downlink			Feeder downlink		
	Output power [W]	[dB W]	EIRP [dB W]	Output power [W]	[dB W]	EIRP [dB W]
11	100.0	20.0	52.1	39.8	16.0	56.9
20	200.0	23.0	55.1	79.4	19.0	59.8

ulation noise. For the K_u band alternative, the result is an output power of approximately 40 W, or 16 dB W. This is a low value, but it is compensated by the high K_u band feeder downlink antenna gain of 40.9 dB. Therefore, the K_u band feeder downlink EIRP is as high as 56.9 dB W. With back-off, the K_a band output power is reduced to about 80 W, equivalent to 19 dB W. Combined with the K_a band feeder downlink antenna gain of 40.8 dB W, the result is an EIRP of 59.8 dB W. The output power figures along with EIRP values for the user and feeder downlink is summarized in Table 7.3 for both the K_u and K_a band case.

7.8 Miscellaneous losses

In satellite communications, there are a few miscellaneous losses that should be taken into account. These additional losses occur in both the satellite and earth stations. The antenna feeder network onboard the satellite will incur a loss which reduce the actual transmitted power. Reduced antenna gain at the edge of a spot beam must also be considered. At the earth stations, antenna pointing errors will result in reduced received signal strength. An implementation loss to account for unavoidable phase inaccuracies and inter-symbol interference degradations is also necessary. These losses are summarized in Table 7.4 and discussed below.

A traditional waveguide connecting a satellite transponder with an antenna can be assumed to attenuate the signal with around 1 dB [33]. In the case of this system, the waveguide connection will be complemented or replaced with a feeder network distributing the power between the four antenna feeder elements creating the desired spot beam. This feeder network can be assumed to reduce the signal strength more than a simple waveguide connection. The feeder network loss, L_{FN} , to be used in the link budget analysis is set to 1.5 dB.

Table 7.4: Summary of miscellaneous losses for K_u and K_a band. The pointing loss range is indicative for antenna diameters between 0.6 m and 1.2 m.

Type of loss		K_u band [dB]	K_a band [dB]
Feeder network loss	L_{FN}	1.5	1.5
Edge of beam loss	L_{EOB}	3.0	3.0
Antenna pointing error loss	L_{APL}	0.1 - 0.3	0.3 - 1.3
Implementation loss	L_{IL}	0.8	0.8

At the edges of the spot beam coverage, the antenna gain will be lower than at the center of the spot beam. In the seven spot beam pattern suggested for this system in section 7.4, the 3 dB beamwidth at apogee is used to define the coverage of the spot beams. A wider beamwidth is used when the satellites are not at apogee, but, as explained in section 7.5, the reduced antenna gain is compensated for by a corresponding reduction in free space loss. Based on this, 3 dB is assumed to be the edge of spot beam loss, L_{EOB} .

The earth stations, especially the smaller user terminals, may not be able to provide accurate antenna pointing. Such pointing inaccuracies can be caused by small tracking errors and influence from external forces. For fixed earth stations, the main external force is wind while mobile users can induce pointing errors through movements that are inadequately compensated for by the terminal equipment. Typical examples for maritime users are roll or pitch motions caused by waves and high seas. In order to limit interference into other systems, maritime VSAT stations, referred to as ESV in the regulations established by the World Radiocommunication Conference (WRC), are required to provide tracking accuracy better than $\pm 0.2^\circ$ [34]. Therefore, this value is assumed to be the maximum pointing error.

The off-axis gain reduction in dB, ΔG , caused by antenna pointing error can be estimated with the help of the following equation:

$$\Delta G = -12 \left(\frac{\Delta\theta}{\theta_{3\text{dB}}} \right)^2 \quad (7.1)$$

where $\Delta\theta$ is the pointing error and $\theta_{3\text{dB}}$ is the 3 dB beamwidth [17]. Gain reduction, or pointing error loss, depends on antenna beamwidth and diameter. Note that the pointing error loss in dB is inversely proportional with the beamwidth. Thus, large antennas will have a higher pointing error loss for a given pointing error than smaller antennas. For the antennas onboard the

satellites the potential pointing error loss is small compared to the edge of spot beam loss. Hence, pointing error loss is assumed to be irrelevant for the satellite antennas.

Pointing error loss can potentially be a factor in the design of earth stations and user terminals. A K_u band antenna with a diameter of 1.2 m will have a pointing loss, L_P , of approximately 0.3 dB for a 0.2° pointing error. Reducing the antenna size down to 0.6 m will reduce the pointing loss to less than 0.1 dB. These figures indicate that the pointing loss has a limited impact in a K_u band link budget. For the K_a band, the situation is slightly different, especially on the uplink. A pointing error of 0.2° will induce a 1.3 dB gain loss in a 1.2 m antenna, and a 0.3 dB gain loss in a 0.6 m antenna. With these levels, the pointing loss can have an influence on the earth station design. Definition of earth station antenna parameters is a subject addressed in Chapter 8. More accurate pointing error loss estimations will be considered there.

Specifications for digital modems typically reflect theoretical and simulated performance, or they are based on measurements in a simplified and controlled environment. Modem imperfections are often caused by frequency conversion problems, filter imperfections as well as timing and phase jitter. As a result, modems normally need a higher E_b/N_o for a given bit error rate than indicated in specifications. The additional E_b/N_o is referred to as the implementation loss. When operating on well-behaved channels, the implementation loss can be kept below 1 dB [35]. In the user guidelines for the DVB-S2 standard, a margin of 0.8 dB is recommended to account for implementation loss [36]. According to that recommendation, the implementation loss, L_I , used in link budget analysis in this study is set to 0.8 dB.

7.9 System noise temperature

There are several sources of noise in a satellite communications system. A receiver generates noise internally in components and wiring. It also receives noise from external sources through the antenna. The total noise level of a receiver is normally referred to as the system noise temperature, T_s , and can be expressed as follows in a satellite system:

$$T_s = T_G + \frac{T_B}{A} + \frac{T_m(A-1)}{A} + T_0(L-1) + T_0(NF-1)L \quad (7.2)$$

where T_G is the equivalent noise temperature picked up by the antenna from the ground, T_B is the brightness temperature, A is the attenuation in the at-

mosphere, T_m is the temperature of the attenuating medium, T_0 is a reference temperature of 290 K, L is the attenuation of lossy elements in the receiver and NF is the noise figure of the amplifier.

Antenna directivity and elevation angle influence the ground noise component, T_G . High gain antennas used for satellite communications typically pick up ground noise equivalent to between 3% and 5% of the physical temperature of the surrounding environment [27]. Therefore, it is assumed to be conservative to use a value for T_G of 15 K. The brightness temperature, T_B , is the background noise temperature of the sky, and it is equal to 4 K. Compared to the other noise components T_B has a negligible impact on T_s and is often ignored in calculations. The level of T_m depends on the medium. In clear sky conditions, a mean path temperature of 270 K is assumed for T_m while it can typically be assumed to be 260 K for rain [22]. Antennas onboard the satellites will observe the warm earth. Thus, the external noise temperature is equivalent to about 280 K.

In a user terminal for satellite communications, the amplification of the received signal is normally performed by a Low Noise Block downconverter (LNB). The LNB is placed close to the antenna and performs two tasks, amplification and downconversion to an intermediate frequency. Downconversion is done to minimize the line loss between the outdoor antenna unit and the indoor modem unit. The noise figure of LNB equipment for satellite communications user terminals has improved significantly over the last decades. Currently, LNB units for K_u band with noise figure as low as 0.6 dB are commercially available. The noise figure for K_a band LNB units are slightly higher, but units with a 1.2 dB noise figure are sold on the commercial market [37]. These noise figure values are used in the calculation of the system noise temperature of the earth stations. It is assumed that the same noise figures are applicable to the low noise amplifiers onboard the satellites.

The attenuation of the lossy elements, L , between the antenna and amplifier depend heavily on cable length. In the design of earth stations, the length of the cable is minimized, and there exist solutions where the LNB is integrated with the feedhorn. Thus, attenuation caused by the lossy elements can be assumed to be low. A value of for L of 0.5 dB is used here, both for the earth stations and the satellites.

In clear sky conditions the worst case attenuation, A , is equal to the atmospheric attenuation identified for the lowest elevation angle in section 6.3.1. When this is used in equation 7.2 together with the other values discussed above, the clear sky receiver system noise temperature is found. The results

Table 7.5: Summary of the estimated clear sky system noise temperature of an typical earth station. Important parameters for the estimation of the system noise temperature is also provided.

Frequency [GHz]	NF [dB]	L [dB]	T_s [K]
11	0.6	0.5	109
20	1.2	0.5	192

Table 7.6: Summary of the estimated receiver clear sky system noise temperature for the satellites. Important parameters for the estimation of the system noise temperature is also provided.

Frequency [GHz]	NF [dB]	L [dB]	T_s [K]
14	0.6	0.5	364
29	1.2	0.5	419

are shown in Tables 7.5 and 7.6 along with important receiver parameters. An earth station using the K_u band, is estimated to have a receiver system noise temperature of 109 K. For the K_a band, the value is 192 K. The receiver system noise temperature onboard the satellite is higher since the satellite antenna only see the warm earth. These values should ensure a good receiver sensitivity.

With rain present in the signal path, the attenuation component of the system noise temperature increase. However, it is only the absorption component of the rain attenuation that adds radio noise. The scattering component of the attenuation increase with higher frequency, and reduce the radio noise generated at a given rain attenuation level. Therefore, a noise temperature calculated using the full rain attenuation level is assumed to establish a conservative worst case estimate. Additional radio noise induced by rain is only relevant for the earth stations. An antenna onboard a satellite will see a constant noise temperature of around 280 K. A rain attenuation value estimated for a given percentage of time can be used to find the system noise temperature for that percentage of time. Using the same receiver parameters as above and attenuation values presented in section 6.3.2, an estimated earth station system noise temperature, T_s , exceeded in less than 0.1 % of the time can be found. The results are shown in Table 7.7.

These noise temperatures are still very low, even during periods of rainfall.

Table 7.7: Summary of the estimated system noise temperature of an typical earth station during rain. The estimations are based on the same receiver parameters as the clear sky estimations and rain attenuation values exceeded for 0.1 % of the time.

Frequency [GHz]	80° N			70° N			60° N		
	$A_{0.1\%}$ [dB]	T_s [K]	ΔT_s [dB]	$A_{0.1\%}$ [dB]	T_s [K]	ΔT_s [dB]	$A_{0.1\%}$ [dB]	T_s [K]	ΔT_s [dB]
11	0.2	122	0.5	0.4	131	0.8	0.8	150	1.4
20	1.1	243	1.0	1.7	268	1.4	3.0	309	2.1

However, it should be noted how the noise level increase caused by rain attenuation affects signal reception. The columns marked ΔT_s in Table 7.7 indicate the ratio in dB between rain influenced system noise temperature and the clear sky system noise temperature. That ratio indicate the effect the increase in noise level has on the carrier to noise density ratio. This reduction in the carrier to noise density ratio comes in addition to the reduction caused by rain attenuation. As the table shows, in the K_u band the noise increase degrades the signal reception more than the rain attenuation while at a similar level in the K_a band. The impact of increased noise is high because of the low clear sky system noise temperatures. When addressing link margins and ACM requirements to countermeasure rain fading, ΔT_s should be considered on the same footing as the rain attenuation.

7.10 Coding and modulation

Both proprietary and standardized solutions for ACM have been explored and implemented in satellite communications. Most of the proprietary ACM implementations have similar performance as the solutions developed by the Digital Video Broadcast (DVB) project and standardized by the European Telecommunications Standards Institute (ETSI). Therefore, it is logical to base the air interface and waveforms used for the provision of satellite communications to the Arctic on the DVB-S2 and DVB-RCS2 standards. The DVB-S2 standard has stipulations for high bandwidth carriers ideal for the forward link of a broadband, backhaul and broadcast service. For broadband users, DVB-RCS2 can be used on the return link, but the high speed return link of the backhaul service should be served with an implementation of DVB-S2.

With multiple users of a communications system, it is necessary to divide the

satellite capacity between them effectively. Commercial satellite communications applications typically use frequency and time sharing, referred to as Frequency Division Multiplexing (FDM) and Time Division Multiplexing (TDM). During the previous discussion on satellite transmit power, it was found advantageous to use TDM on the forward link. For the return link FDM was deemed feasible. The system model of DVB-S2 and DVB-RCS2 when used for broadband communications dictate a wide TDM carrier on the forward link. For the broadband return link, a number of smaller carriers with TDMA or TDM are used. Such an organization of the return link is often referred to as Multi Frequency Time Division Multiple Access (MF-TDMA) and is a combination of FDM and TDM [38, 39]. For the backhaul service, it is envisioned that a small number of earth stations share a wide DVB-S2 carrier on the forward link. On the return link, each backhaul earth station generates a small DVB-S2 carrier.

Data transmission on the forward link to individual users occurs in short bursts. Thus, a user may be receiving its data at a low overall bit rate, but the actual instantaneous bit rate is higher as other users also are receiving data on the same carrier. The link budget of the forward link must be designed so earth stations are able to receive the whole forward link. In theory, it is then possible to assign the whole carrier to serve a single earth station. TDM on the forward link require a high basic performance for support of services, but it adds substantial flexibility in the allocation of satellite capacity. The forward link is designed with the same symbol rate for all broadband and backhaul service levels. However, with different capabilities and link margins, higher performing earth stations will be able to support higher bit rates than the smaller earth stations. In DVB-S2 variation of the carrier's ACM level based on user capabilities is supported. This is also referred to as non-uniform error protection. Hence, earth stations with different receiving capabilities and link margins can share a DVB-S2 carrier on the forward link, and receive their data with different instantaneous bit rates.

The implementation of MF-TDMA on the broadband service return link allows multiple earth stations to communicate to a gateway or central hub, sharing a set of frequencies which are divided into time slots. Transmissions are performed as bursts in time slots, but multiple time slots can be assigned to a single user [39, 40]. The maximum bit rate available to an earth station is reached when all time slots on a frequency channel is assigned to that user. As the frequency channels are shared between users, the instantaneous bit rates should be higher than the bit rates indicated by the service levels discussed in section 2.4. However, since the assignment of time slots can be adjusted

according to transmission demand, the instantaneous bit rates require only a limited increase from the overall bit rates. It is envisioned that the high speed broadband services can be supported by an instantaneous bit rate equal to the overall bit rate. For the lower level broadband services, the instantaneous bit rates are addressed in connection with the discussion on earth station design and performance in the next chapter. The backhaul earth stations will use a dedicated DVB-S2 carrier for the return link with an instantaneous bit rate matching that indicated by the service level.

DVB-S2 is a modern air interface standard which takes advantage of advanced coding and modulation technologies. One of its additional main advantages is the provision for ACM. The large ACM span of DVB-S2 provides the possibility for an outstanding dynamic range. Required carrier to noise density ratio of the lowest bit rate QPSK $1/4$ mode is 18.4 dB lower than those of the highest bit rate 32APSK $9/10$ mode. Thus, a system designed for support of 32APSK $9/10$ in clear sky conditions can still transmit data when the signal is attenuated 18.4 dB. During periods of signal fading, the coding and modulation level is adjusted down to match the fading ensuring the connection is not lost. Lower level coding and modulation have reduced E_b/N_o requirements. The carrier to noise density requirements are additionally reduced because of the lower bit rates of the low level coding and modulation modes. Thus, if a constant bandwidth is assumed, the throughput is reduced when ACM is used as a countermeasure against signal fading [38].

The forward link should be dimensioned and designed with the aim of using 32APSK $9/10$ as the nominal coding and modulation scheme for the backhaul service. Earth stations for broadband services will be less capable, thus potentially support a less efficient nominal coding and modulation mode. This is implementable with DVB-S2 since carriers with non-uniform coding and modulation modes is supported by the standard. The nominal coding and modulation mode applicable for the different earth station types and service levels, will be considered as part of the link budget assessment in the next chapter.

In section 2.4, two backhaul service levels were suggested. Those were level A providing 20 Mbit/s in both directions and level B providing 10 Mbit/s in both directions. The bandwidth, B_c , required to support a certain bit rate, R_b , is given as:

$$B_c = \frac{R_b}{\eta_s}(1 + \alpha) \quad (7.3)$$

where η_s is the spectral efficiency of the coding and modulation scheme used and α is the roll-off factor. DVB-S2 support a roll-off factor as low as 0.2

and 32APSK $9/10$ has spectral efficiency of about 4.45 bit/s/Hz. Therefore, a backhaul service level A user will ideally occupy a bandwidth of about 5.4 MHz. Allowing for bandwidth imperfections, overhead and potentially less effective coding, a bandwidth of 6.0 MHz is assumed for nominal support of a 20 Mbit/s bit rate. On the backhaul service return link, each user transmits an individual carrier. Thus, service level A will have a carrier bandwidth of 6.0 MHz while service level B will have a 3.0 MHz carrier bandwidth. The forward link will use a wide TDM carrier bundling the traffic of several users. If six backhaul service level A users are supported on the same carrier, it would require a satellite transponder bandwidth of 36 MHz. This is assumed to be a reasonable transponder bandwidth and is used for all services.

DVB-RCS2 also have provisions for ACM, which allow fade mitigation on the return link of the broadband service. With fewer available coding and modulation modes in DVB-RCS2, the ACM span is less than that offered by DVB-S2. A switch from the most spectral efficient 16QAM $5/6$ mode to the most robust QPSK $1/3$ mode reduces the required carrier to noise density ratio by approximately 12.5 dB. Such an ACM span should ensure connectivity even during periods of severe signal fading.

The return link of the highest broadband service level should be designed to support the most efficient 16QAM $5/6$ coding and modulation mode in clear sky conditions. It is assumed the instantaneous bit rate of this service level can be in the area of the overall bit rate of 4.0 Mbit/s as defined in section 2.4. From equation 7.3, it can be calculated that a channel bandwidth of approximately 1.6 MHz is the minimum requirement for the provision of this bit rate. A roll-off factor of 0.2 is then assumed. A return link channel bandwidth of 2.0 MHz is suggested for the high performing broadband services. Such a channel bandwidth can potentially allow for instantaneous return link bit rates close to 5 Mbit/s. It would also be possible to provide the uplink speed suggested for broadband service level D using only the second most efficient coding and modulation mode of DVB-RCS2. Identification of nominal modulation and coding modes, as well as the potential link margins, for the other broadband service levels, require link budget analysis. During such analysis, reducing the channel bandwidth to 1 MHz or less for broadband service levels A and B should also be considered. In the next chapter on earth station design and performance, this will be addressed.

The cost effectiveness of satellite broadcasting spur from the possibility to distribute the same signal to many users easily. ACM control on an individual user level is, therefore, not an option in a broadcasting service. The least ca-

pable broadcasting service receiving earth stations should dictate the selection of coding and modulation mode. This specification will be considered in the next chapter. Another feature of broadcasting services is that they are not very amenable to bit rate changes as the content is viewed in real time. It is possible to reduce the quality and resolution of content for lower bit rates, but in this study the implications of this possibility is not considered. Hence, a constant coding and modulation should be used for the broadcasting service. The availability of the broadcasting service will then differ depending on the capabilities of the different earth station types. The smallest user terminals should not be expected to provide availability of substantially more than 99 % of the time. Based on the rain attenuation effects presented in Table 7.7 for 70° northern latitude, it should then be adequate with a rain margin of 1.0 dB in K_u band and 1.5 dB in K_a band.

Distress and safety services require high availability. They are also typically low data rate services. Therefore, it is logical to implement them with the most robust coding and modulation scheme, namely QPSK 1/4. This mode is not robust enough to support the use of omnidirectional user terminal antennas for distress messages, but it is possible to use fairly small and wide beamed antennas. A more detailed discussion can be found in section 8.4.4.

7.11 Doppler shift

A relative motion between the transmitter and receiver in a radio system will induce a shift in frequency, often referred to as a Doppler shift. The change in frequency is proportional to the relative velocity and the carrier frequency. As HEO satellites are not stationary, a Doppler shift will be observable both at the satellite and the ground. The sub satellite point move fairly slowly, but the relative velocity between satellite and earth stations can nevertheless be significant. This is because of the high eccentricity of the chosen orbit, which result in quite fast altitude changes, especially around the point of handover.

Relative velocity between satellite and earth station is not the same across the coverage area. The position where the highest relative motion between satellite and earth station can be observed is at 60° northern latitude and a longitude equal to that of the apogee location. The Doppler shift will change during the active period of a satellite. This variation is illustrated in Figure 7.12. A stationary earth station is assumed in the simulations performed to create the plot. The change in frequency will be less than that indicated

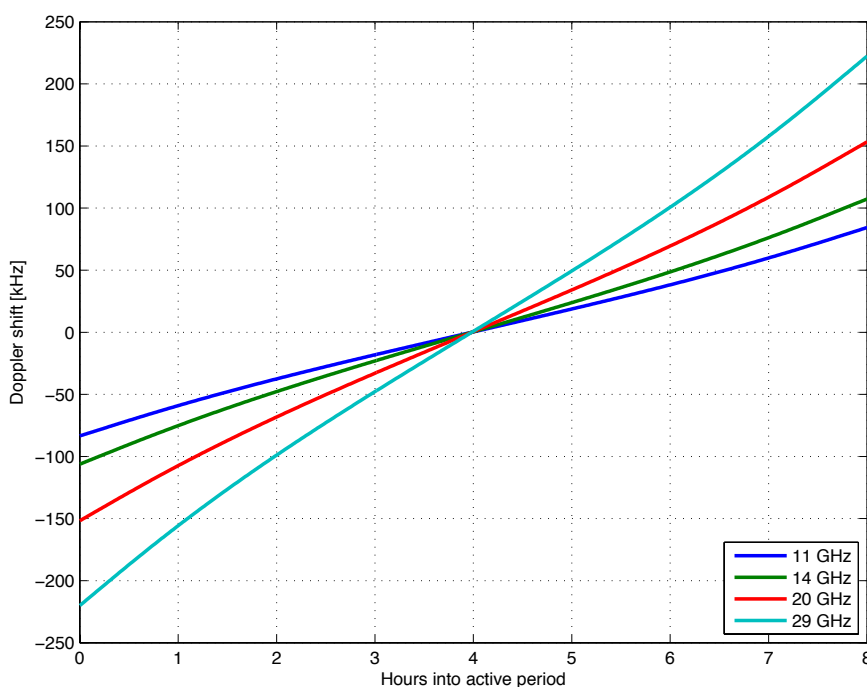

Figure 7.12: Variation of the Doppler shift for the downlink and uplink of K_u and K_a band during the eight hours a satellite is active. The simulated results are for the position with the highest relative velocity, which is located at 60° North and with the same longitude as the apogee position.

in Figure 7.12 for all other positions within the extended coverage area. An earth station positioned in the middle of the two apogee positions at 60° North will experience the lowest Doppler shift. There, the frequency shift is approximately 86% lower than at the apogee longitude.

In a HEO satellite communications system, the Doppler shift will be quite large and significant. The maximum Doppler shift ranges from about 84 kHz to 222 kHz, depending on frequency. Table 7.8 summarizes the maximum Doppler shift for the four relevant frequencies. These values are significantly higher than a Doppler shift induced by a mobile user terminal. The movements of an aeronautical K_u band terminal can typically create a Doppler shift of around 15 kHz. A moving maritime terminal shifts the frequency less than 500 Hz [41]. Thus, it is evident that movements of the HEO satellites suggested for this system cause frequency shifts which require attention. Solutions implemented in GEO systems for Doppler mitigation might not be able to handle this additional frequency shift without appropriate modifications.

Table 7.8: Summary of key doppler shift simulation results for the downlink and uplink frequencies of K_u and K_a band. The values are applicable for an earth station located at 60° northern latitude and the same longitude as the apogee position.

Frequency [GHz]	Max doppler shift [kHz]	Max rate of change [Hz/s]	Change at handover [kHz]
11	84.3	7.0	167.8
14	107.3	8.9	213.5
20	153.3	12.7	305.0
29	222.3	18.4	442.3

The maximum frequency shift is not the only aspect of Doppler shift that has an effect on communications. For countermeasure mechanisms, the rate of change can be just as important as the magnitude. Doppler shift induced by a HEO satellite has a very modest rate of change. Simulations indicate a maximum rate of change between about 7 Hz/s and 18 Hz/s . More accurate values are listed in Table 7.8. Such rates of change are well below what can be expected from mobile terminals. Even a pedestrian with a mobile K_u band user terminal can cause a Doppler shift rate of change reaching 50 Hz/s . For an aeronautical K_u band user terminal, the rate of change can be in excess of 800 Hz/s [41]. Thus, the rate of change in Doppler shift induced by satellite relative motion in a HEO system is manageable. Earth stations designed for mobile operations towards GEO are not expected to require modifications to follow the change in frequency caused by HEO satellites.

At the handover between two satellites, the rate of change in Doppler shift is not moderate. The two satellites will move almost in the opposite direction of each other. While the outgoing satellite will have a decreasing altitude, and move towards the earth stations, the incoming satellite will have an increasing altitude, and move away from the earth stations. Hence, the Doppler shift will change from positive to negative. Since the Doppler shift is largest around handover, the frequency change at handover is close to twice the maximum value. Simulated results for the change in Doppler shift at handover are given in Table 7.8. Such a large change in frequency can be a challenge to handle. However, it is assumed that this issue is possible to solve as part of the handover operation.

Uncompensated Doppler shift can cause problems both onboard the satellites and at the earth stations. Transmissions sent correctly from the ground may arrive at the satellite at a frequency overlapping an adjacent channel or

even outside the frequency band used by the system. On the downlink, a large Doppler shift can cause signal lock difficulties for earth stations. Thus, compensation of the Doppler shift is necessary. There are a few alternative approaches for Doppler compensation in a satellite communications system. These can be divided into three categories:

1. Reception of the nominal frequency at the earth stations. Doppler compensation can occur in the satellites and transmitting earth stations.
2. Transmission of the nominal frequency by the earth stations. Doppler compensations can occur in the satellites and receiving earth stations.
3. The satellites receive and transmit on the nominal frequencies. Doppler compensation is required in both the transmitting and receiving earth stations

In the first case, the Doppler shift compensation can be performed either end-to-end by the transmitting earth station, all at the satellite or as a combination. The second alternative also allows end-to-end compensation, but it must be performed at the receiver. All compensation done by the satellite is also possible, as well as a combination of satellite and receiver compensation. In the third alternative, end-to-end compensation is not possible since the frequencies should be nominal at the satellite.

Appropriate Doppler shift compensation will be dependent on the position of an earth station. Earth stations at different positions require a unique frequency change to compensate for the Doppler shift. For a large TDM carrier, this is difficult to do adequately both at the satellite and end-to-end. Such compensation would require the carrier frequency to be changed slightly between frames intended for different users. Onboard a transparent satellite, such an operation is not possible. Individual end-to-end compensation performed at the central hub for each earth station is assumed to be complex and difficult to implement. Thus, for the forward link the third alternative approach is deemed to be the best. On the return link, end-to-end compensation can be easier to implement. However, to simplify the system architecture, the third Doppler compensation approach alternative should be used there as well.

Thus, each earth station must compensate for the Doppler shift both when receiving and transmitting. That is done by shifting the frequency according to the Doppler shift. The Doppler shift can be calculated by each earth station based on the position of both itself and the satellite it is using. Both these position variables can be expected to be known by the earth stations. Through this Doppler compensation technique, the satellites will always receive and

transmit the nominal frequency. That is expected to make the satellite payload design less complex. It also increases the flexibility of capacity allocation to services and allow for more efficient utilization of satellite resources.

Guidelines for the use of DVB-RCS2 in mobile scenarios have been issued by ETSI. Doppler shift is one of the topics addressed there. It is expected that similar techniques and solutions provided there, and in the main standard specifications on how to handle Doppler shift is applicable. The simulations performed here indicate a maximum shift in frequency which are around the tolerance levels allowed in the DVB-RCS2 standard [41, 42]. Therefore, it is likely that some modifications are necessary for the proper functionality in a HEO based satellite communications system. However, it is assumed that these adaptations can be implemented in GEO designed user terminals through software updates.

7.12 Handover between satellites

In the satellite constellation used as a baseline in these system considerations, continuous coverage of the Arctic and high latitude areas is realized with three satellites. Two of the satellites will be active and available at the same time around different apogee positions while the third satellite is moving from one apogee area to the other. On regular intervals, one of the active satellites will be replaced by the third satellite on the way towards apogee. At that point traffic must be handed over from the outgoing satellite to the incoming satellite.

The satellites in the 12H3S3P constellation proposed for Arctic communications coverage, have a ground track with a closed loop around apogee. In Chapter 4, it was suggested that the ground track intersection point can be used for handover of traffic between satellites. As the incoming and outgoing satellites are close to each other at this point, seamless handover with only one user terminal antenna is assumed to be possible. It is important to understand that even though the two satellites are close to each other at the ground track intersection point, there is a considerable distance between them. This distance is necessary to ensure that the satellites do not collide with each other. Therefore, high performing earth stations with large antennas may have antenna beams that are too narrow for communications with both satellites at the same time. Such stations must either have an additional antenna, or tolerate a few seconds of connection loss as the antenna repoints and synchronizes with the incoming satellite.

Transfer of traffic from one satellite to the other require careful coordination, both for the forward link and the return link. It is an advantage for the system that handover occur at a predefined and well known time. Each apogee location switches satellite every eight hours. This knowledge of handover time allows planning and adaption of the traffic stream to fit with the handover procedure. With handover being a regular occurrence for this satellite system, it is important to establish an automated and fixed procedure which can be used at every handover.

A gateway, or central hub, will be equipped with very large antennas for support of the feeder link. These antennas will have a narrow antenna beam that are unable to communicate with both the incoming and outgoing satellites simultaneously, even when they pass the ground track intersection point. Thus, a double set of antennas is needed to ensure a smooth handover of traffic from one satellite to the other. One antenna set will track and handle communications with the outgoing satellite while the other antenna set will track and handle communications with the incoming satellite. It is important to remember that the Doppler shift will be different for the two satellites. The two sets of antennas can, therefore, not be tuned to the same frequency as they must be adjusted to compensate for the Doppler shift.

Forward link traffic destined to user terminals with antenna beams wide enough for communications with both satellites at handover should be fairly easy to handle. Transmission of the uplink carriers containing such traffic can at the moment of handover be switched to the gateway antennas tracking the incoming satellite. This maneuver should be adequate to move this traffic from one satellite to the other. The timing of the handover must be predetermined and broadcasted to all active user terminals. They must be ready to adjust their receiving frequency to compensate for the difference in Doppler shift between the incoming and outgoing satellites. Transmissions through the incoming satellite should start with a brief synchronization pilot. This will allow the user terminals to tune into the slightly different frequency and properly adjust the Doppler compensation.

Handover of return link traffic from wide beam user terminals should also be fairly straight forward. At a predetermined time, the user terminals change their Doppler compensation to be in accordance with the incoming satellite. The outgoing satellite switches at the same time off the transponders handling this return link traffic and the corresponding transponders are switched on at the incoming satellite. Traffic will then automatically have moved to the gateway antenna set pointed towards the incoming satellite and traffic

handover is complete. Also for this traffic a brief synchronization pilot should be transmitted as the user terminals start sending on the frequency Doppler shift compensated to match with the incoming satellite.

More advanced earth stations with antenna beams too narrow for truly seamless handover must also be considered in terms of handover. Earth stations equipped with two fully redundant antennas can use a strategy similar to the one used at the gateways. One of the antennas track and communicate with the outgoing satellite while the other antenna track the incoming satellite. At the predetermined time of handover, the earth station switch to the antenna tracking the incoming satellite. Following the brief synchronization pilot traffic should be successfully handed over to the new satellite, both for the forward and return link.

Advanced narrow beamed earth stations with only one antenna available cannot support seamless handover. This is valid not only for earth stations equipped with only one antenna, but potentially also for earth stations with two antennas. If one of two antennas is unavailable at the time of handover, seamless handover is not possible for earth stations with narrow beamed antennas. Unavailability can be due to equipment malfunction or only temporary blockage of the line of sight towards the satellites. Systems without seamless handover support must stop all communications before the time of handover, and wait for the antenna to realign with the incoming satellite. When the antenna has been repointed towards the incoming satellite, the earth station can log on to the system again and continue communications. To prevent unnecessary transmissions and data loss, earth stations without seamless handover support should in advance notify the gateway of their inability to continue communications seamlessly through the handover process.

Definition of the exact implementation of satellite handover in the various system components is outside the scope of this study. The discussion and considerations presented here indicate the basic principles on a system level. A detailed handover protocol describing necessary signaling traffic, length of synchronization pilots and necessary terminal modifications require further study. However, based on existing implementations of spotbeam and satellite handover in DVB-RCS2, it is expected that the necessary differences from normal GEO operations can be dealt with through software upgrades of earth stations and user terminals.

Chapter 8

Earth station design and performance

Provision of communications services in a satellite system depend heavily on earth station design and performance. Support of various services depends on earth station antenna dimensions, transmit power and appropriate coding and modulation. Users prefer small antennas and low power systems as they are easy to accommodate, install and maintain, both for fixed and mobile applications. However, large and powerful earth stations allow for more efficient utilization of satellite resources. A trade-off between such considerations is necessary for optimal design of earth stations providing a desired performance.

Gateway earth station parameters are considered and defined first in this chapter. It is proposed to use large gateway antennas with a diameter of 7 m for the K_u band and 13 m for the K_a band. Next, results from link budget analysis of the forward and return links are presented. The analysis look at earth station antenna diameters and transmitting power required for support of different bit rates and services as they were defined in section 2.4. The findings are used to define earth station parameters for the various services. Performance estimations based on these earth station parameters are presented for the different services and earth stations. A preliminary analysis of the interference induced into GEO by the HEO system is then given, and the results are positive. At the end of the chapter the advantages and disadvantages of the two frequency band alternatives are considered, and it is concluded that further studies are needed before a credible decision on choice of carrier frequency can be made. Especially the difference in space segment cost between the two frequency band alternatives must be explored.

8.1 Gateway station parameters

An earth station acting as a gateway or central hub is designed and operated differently in the K_u and K_a bands, especially on the forward link. Gateway stations for systems operating in the K_u band typically employ a High Power Amplifier (HPA) for each satellite transponder. The forward link in the suggested system will have a single carrier with a bandwidth of 36 MHz per transponder. Hence, also a single carrier per HPA at the gateway station. In the K_a band a gateway station HPA typically have a wider bandwidth and handle the traffic for multiple satellite transponders. HPA bandwidth between 500 MHz and 1 GHz is common in K_a band gateways.

For operations in both the K_u and the K_a band an HPA providing a power of around 500 W are used. Unfortunately, amplifiers at this power level have highly non-linear performance characteristics. Therefore, a large Output Back-Off (OBO) is necessary in order to minimize non-linear effects, such as intermodulation noise, phase errors and inter symbol interference. In a gateway earth station, there will also be substantial losses in waveguides, combiners and output filters. The various losses are distributed differently in the K_u and K_a band systems. However, in sum the reduction in effective power at the antenna input is typically in the same order of magnitude. Thus, in both the K_u and K_a band case a reduction in effective output power of around 10 dB is expected. A 500 W HPA will then supply the antenna with approximately 17 dB W.

In the K_u band case, communications will be supported through the gateway earth station with a HPA for each satellite transponder. With each satellite transponder on the forward link handling a single carrier of 36 MHz, the resulting carrier power is 17 dB W. The wide HPA bandwidth typically used in a K_a band gateway earth station will handle several such carriers. Hence, the carrier power in the K_a band case is lower. Assuming a K_a band HPA bandwidth of 500 MHz, 13 carriers of 36 MHz can be handled by a HPA. Assuming the available power is evenly distributed among the 13 carriers, the result is a carrier power of approximately 6 dB W.

The lower carrier power used in the K_a band systems compared to the K_u band systems is compensated through the employment of larger gateway station antennas. K_u band feeder link antennas are between 5 m and 7 m in diameter. An uplink antenna gain of 58.3 dB can be expected if a 7 m antenna with aperture efficiency of 65 % is assumed. EIRP per carrier on the forward uplink in the K_u band case would then be 75.3 dB W. K_a band gateway stations use

Table 8.1: Summary of the gateway earth station parameters for the two frequency bands.

Parameter		K _u band	K _a band	Unit
Antenna diameter	d_g	7.0	13.0	m
Gateway uplink gain	G_{gu}	58.3	70.1	dB
Power per carrier	P_c	17.0	6.0	dBW
EIRP per carrier	$EIRP_c$	75.3	76.1	dBW
Gateway downlink gain	G_{gd}	56.3	66.8	dB
Gain to noise temperature ratio	G/T	35.9	47.3	dB/K

feeder link antennas as large as 13 m. With the same aperture efficiency, such an antenna can be expected to have an uplink antenna gain of 70.1 dB. The resulting EIRP per carrier would be 76.1 dB.

On the feeder downlink, a 7 m K_u band antenna should provide an antenna gain of 56.3 dB. Combined with the clear sky system noise temperature found in section 7.9, this indicates a G/T ratio of 35.9 dB/K. In the K_a band, the 13 m gateway antenna produces a downlink antenna gain of about 66.8 dB. The K_a band clear sky system noise temperature of a receiving earth station of 192 K from section 7.9 suggests a G/T ratio of 47.3 dB/K. Also, in these calculations aperture efficiency of 65 % is used. Table 8.1 summarizes all the gateway earth station parameters for the two frequency bands, including both uplink and downlink.

8.2 Forward link

The various system parameters discussed in previous chapters combined with the gateway parameters considered above allow for the construction of a link budget for the forward link. User terminal antenna dimension is the only forward link parameter that is undefined. Thus, link budget calculations can be performed for the forward uplink. The results are shown in Table 8.2 for both the K_u and K_a bands. Clear sky conditions are assumed.

Link budgets for the forward downlink require earth station antenna diameter for completion. Earth station antenna diameter is necessary to calculate the downlink antenna gain and antenna pointing loss. The other parameters have already been defined or calculated and are listed in Table 8.3. If the earth station antenna diameter is treated as a variable, it is possible to calculate the

Table 8.2: Clear sky link budget for the forward uplink on both K_u and K_a band.

Parameter		K_u band	K_a band	Unit
<i>Gateway</i>				
Power per carrier	P_c	17.0	6.0	dBW
Uplink antenna gain	G_{gu}	58.3	70.1	dB
EIRP per carrier	$EIRP_c$	75.3	76.1	dBW
<i>Propagation</i>				
Free space loss	L_{FSL}	207.6	213.9	dB
Atmospheric attenuation	L_{PL}	0.2	0.6	dB
<i>Satellite</i>				
Uplink antenna gain	G_{FL}	43.0	44.0	dB
Receive system noise temperature	T_{sat}	25.6	26.2	dBK
Boltzmanns constant	k	-228.6	-228.6	dBW _s /K
<i>Uplink result</i>				
Carrier to noise density ratio	C/N_{oFU}	113.5	108.0	dB Hz

Table 8.3: Summary of clear sky link budget parameters for the forward downlink on both K_u and K_a band.

Parameter		K_u band	K_a band	Unit
<i>Satellite</i>				
User link transmit power	P_{UL}	20.0	23.0	dBW
Feeder network loss	L_{FN}	1.5	1.5	dB
User link antenna gain	G_{UL}	32.1	32.1	dB
EIRP per carrier	$EIRP_{SC}$	50.6	53.6	dBW
<i>Propagation</i>				
Free space loss	L_{FSL}	205.5	210.7	dB
Atmospheric attenuation	L_{PL}	0.1	0.6	dB
<i>Earth station</i>				
Edge of beam loss	L_{EOB}	3.0	3.0	dB
Implementation loss	L_{IL}	0.8	0.8	dB
Receive system noise temperature	T_s	20.4	22.8	dBK
Boltzmanns constant	k	-228.6	-228.6	dBW _s /K

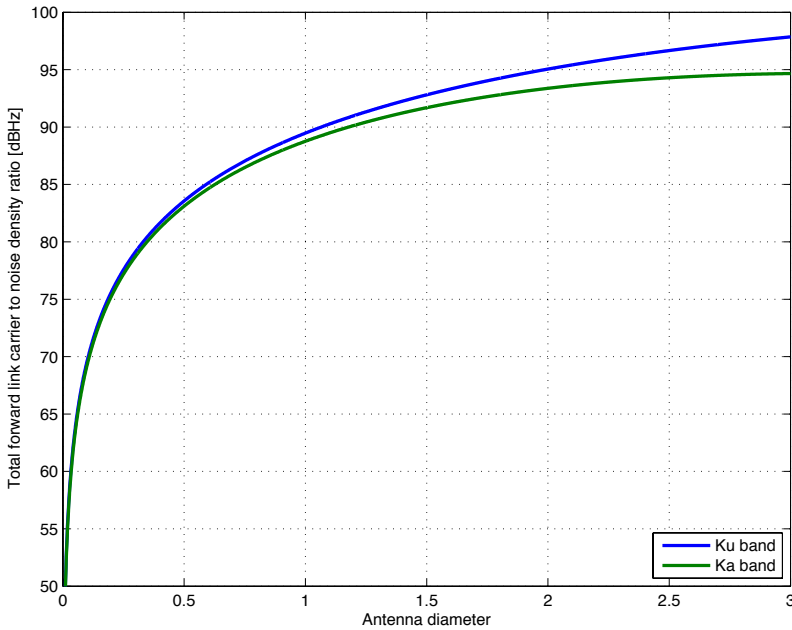

Figure 8.1: Overall forward link carrier to noise density ratio as a function of earth station antenna diameter.

forward downlink received carrier to noise density ratio, C/N_{oFD} , as a function of earth station antenna diameter. This can in turn be combined with the forward uplink carrier to noise density, C/N_{oFU} . The resulting overall carrier to noise density ratio for the forward link, C/N_{oF} , as a function of earth station antenna diameter is shown in Figure 8.1. These results assume clear sky conditions and incorporate an earth station antenna pointing loss induced by a pointing error of 0.2° .

It is suggested to use the DVB-S2 standard as air interface on the forward link. A 36 MHz carrier should fill a satellite transponder in both the K_u and K_a band cases. A key issue in a satellite communications system is the bit rates possible to receive at the earth stations. The results displayed in Figure 8.1 in combined with spectral efficiency and error performance of the different DVB-S2 coding and modulation modes can provide possible bit rates as a function of antenna diameter. Figure 8.2 and 8.3 show the K_u and K_a band results for the 28 different coding and modulation modes defined by DVB-S2.

The potential throughput on a carrier, such as shown in Figure 8.2 and 8.3, can either be power limited or bandwidth limited. In a DVB-S2 power limited

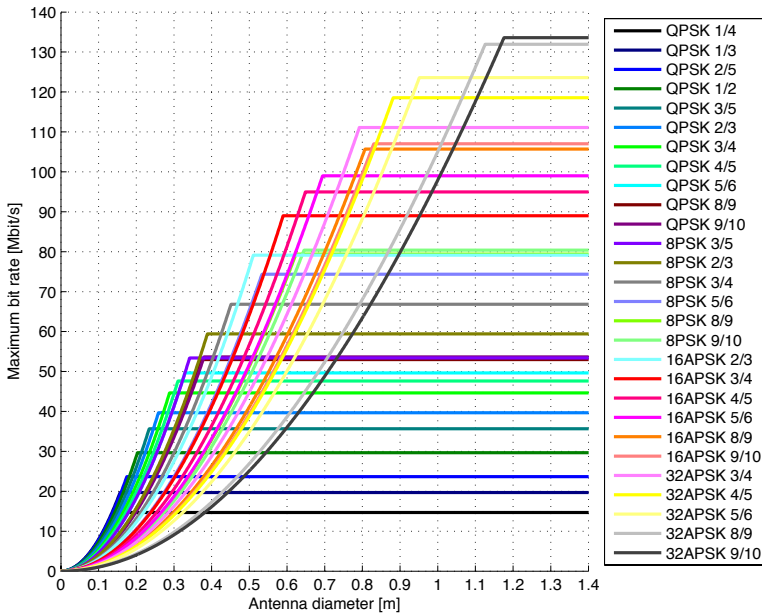

Figure 8.2: Possible bit rates for the different coding and modulation modes defined by DVB-S2 as a function of earth station antenna diameter for the K_u band case.

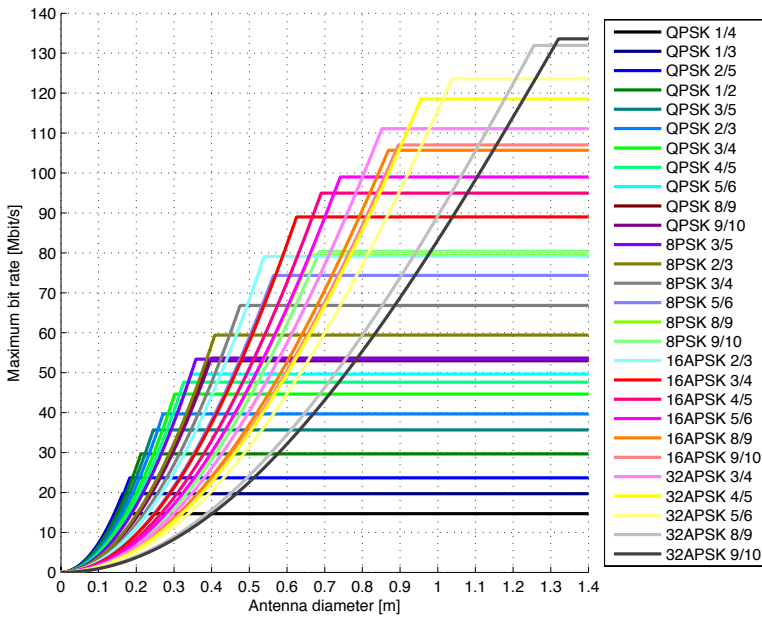

Figure 8.3: Possible bit rates for the different coding and modulation modes defined by DVB-S2 as a function of earth station antenna diameter for the K_a band case.

scenario the maximum bit rate that can be received under quasi error free conditions, R_p , is given by:

$$R_p = \eta_s \frac{C/N_o}{E_s/N_o} \quad (8.1)$$

where η_s is the spectral efficiency, C/N_o is the carrier to noise density ratio on the link and E_s/N_o is the average symbol energy to noise density ratio. The sloping part of the potential bit rates for the different DVB-S2 modes shown in Figure 8.2 and 8.3 follows this equation.

As C/N_{oF} increases with the earth station antenna diameter, a wider carrier transferring more information can be supported. When the carrier bandwidth reaches its maximum, in the suggested system 36 MHz, the maximum bit rate changes from being power limited to bandwidth limited. The bit rate of a bandwidth limited carrier, R_b , is given as:

$$R_b = \frac{B_c \eta_s}{1 + \alpha} \quad (8.2)$$

where B_c is the carrier bandwidth and α is the roll-off factor. In a bandwidth limited scenario, the bit rate is constant and independent of C/N_{oF} and antenna diameter. The horizontal lines in Figure 8.2 and 8.3 indicate antenna diameters where the different DVB-S2 modes are bandwidth limited.

The intention is to serve different types of users with various service levels on the same carriers. A fixed symbol rate should, therefore, be used on the forward link for traffic to all types of earth stations. For maximum utilization of capacity and resources this symbol rate should be chosen to take advantage of the whole transponder bandwidth of 36 MHz. In terms of potential bit rates these equate to the bandwidth limited scenarios in Figure 8.2 and 8.3. With a fixed symbol rate, the potential throughput on a 36 MHz carrier as a function of earth station antenna diameter can be illustrated as in Figure 8.4 and 8.5. The steps illustrate well how the spectral efficiency of the employed coding and modulation mode decreases with reduced antenna diameter. Correspondingly the throughput and potential instantaneous bit rate go down when smaller antennas are used.

The findings displayed in Figure 8.4 and 8.5 provide useful information on the throughput potential for different antenna diameters. This information can be helpful when dimensioning earth station antennas for user terminals supporting the different services and their service levels. Antenna diameter of a receive only user terminal for broadcasting services can be selected based on these

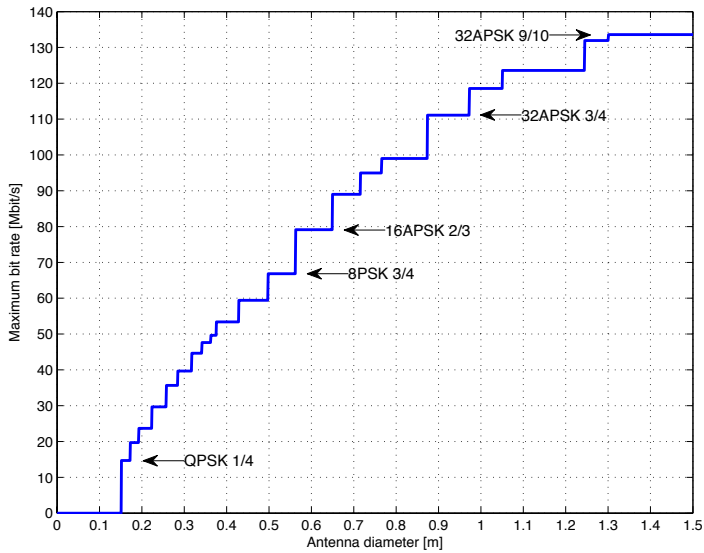

Figure 8.4: Maximum throughput on a 36 MHz forward link carrier in a HEO satellite based Arctic communications system using K_u band, as a function of earth station antenna diameter. The different steps indicate various modulation and coding modes according to DVB-S2. Clear sky conditions are assumed.

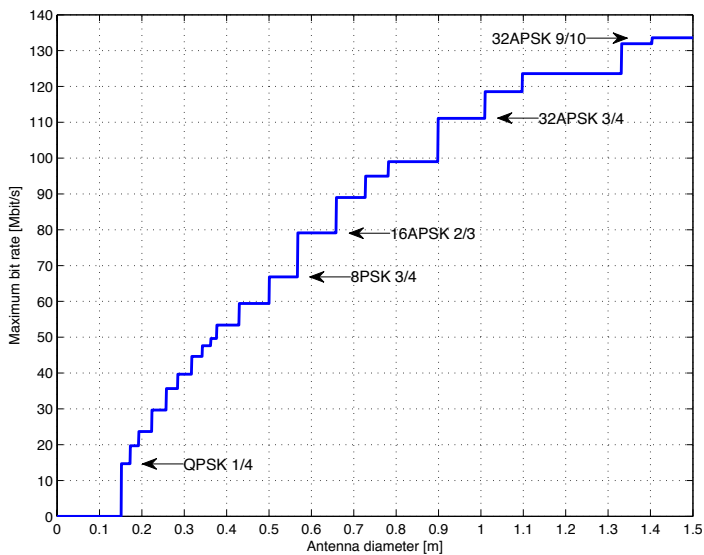

Figure 8.5: Maximum throughput on a 36 MHz forward link carrier in a HEO satellite based Arctic communications system using K_a band, as a function of earth station antenna diameter. The different steps indicate various modulation and coding modes according to DVB-S2. Clear sky conditions are assumed.

Table 8.4: Summary of nominal coding and modulation mode with instantaneous channel bit rate, R_b , suggested for the forward link of various services in clear sky conditions. Antenna diameter necessary to support this mode is also provided along with potential link margin for the broadcast and distress and safety services.

Service	Mode	R_b [Mbit/s]	Antenna diameter		Link margin [dB]
			K_u [m]	K_a [m]	
Broadband A/B	16APSK $2/3$	79.1	0.56	0.57	-
Broadband C	32APSK $3/4$	111.1	0.87	0.90	-
Broadband D	32APSK $9/10$	133.6	1.30	1.40	-
Backhaul A/B	32APSK $9/10$	133.6	1.30	1.40	-
Broadcast	8PSK $3/4$	66.8	0.56	0.57	1.0
	8PSK $2/3$	59.4	0.56	0.57	2.4
Distress and safety	QPSK $1/4$	14.7	0.32	0.32	6.4
	QPSK $1/4$	14.7	0.34	0.34	7.0

findings. Interactive services, such as backhaul, broadband and distress and safety, will, on the other hand, also need to consider the implications of the return link. However, the results shown in Figure 8.4 and 8.5 can be used to establish some minimum antenna diameters necessary for adequate forward link support. The findings are summarized in Table 8.4 and discussed below.

Earth station antenna diameters should be as small as possible while still providing the bit rates specified by the various service levels suggested in section 2.4 in a capacity efficient manner. In clear sky conditions backhaul services should be able to employ the most efficient coding and modulation mode. The K_u band case supports the use of 32APSK $9/10$ on the forward link when the earth station antenna is larger than 1.30 m in diameter. For the K_a band case, the earth station antenna must be slightly larger as a diameter of 1.40 m is necessary. Use of 32APSK $9/10$ on a 36 MHz carrier result in an instantaneous bit rate of 133.6 Mbit/s. The intention is to time multiplex several users, potentially at different services and levels, on this capacity. Thus, a single backhaul user will nominally only use 10 Mbit/s to 20 Mbit/s of this capacity, but it can potentially be allocated to a single user.

From Figure 8.4 and 8.5 it is evident that a high performance is possible also with smaller earth station antennas. This should, therefore, be considered for the other services. In section 2.4 it was suggested to support broadband communications with four service levels. Service level D supports the highest bit rates of those four. The downlink, or forward link, speed of 8 Mbit/s is

close to that of the lowest backhaul service. Hence, a minimum earth station antenna diameter equal to that of the backhaul service is assumed appropriate, 1.30 m in the K_u band and 1.40 m in the K_a band. For the other broadband service levels smaller antennas should be considered.

In Figure 8.4 and 8.5 it can be observed that some of the steps are larger than others. An earth station with antenna diameter slightly larger than these steps will provide a significantly efficiency improvement over an earth station with antenna diameter slightly smaller than these steps. Therefore, it is suggested targeting broadband service level C for nominal use of 32 APSK $3/4$ on the forward link. In the K_u band, this requires an antenna diameter of at least 0.87 m. For the K_a band case, the antenna must have a slightly larger diameter of 0.90 m. With a 36 MHz carrier, the instantaneous bit rate of such a link will be 111.1 Mbit/s .

There is a similar step in throughput up to 16APSK $2/3$. Therefore, it is appropriate to target that mode for nominal clear sky operations with broadband service level A and B. The same mode is chosen for these two service levels to ensure an effective use of capacity and satellite resources. In the K_u band the earth station antenna must be larger than 0.56 m to support this modulation and coding mode. Operations in the K_a band requires an antenna diameter of at least 0.57 m. An instantaneous bit rate of 79.1 Mbit/s is transferred over a 36 MHz carrier when 16APSK $2/3$ is used.

During the discussion on coding and modulation in section 7.10, it was stated that the broadcasting service is assumed to be provided with a constant coding and modulation mode. An extra margin should be incorporated to mitigate the effects of rain. The broadcasting service should be be receivable by the smallest broadband terminals. Using the above considerations on the broadband service levels A and B as a reference, a link margin will be added if a coding and modulation mode more robust than 16APSK $2/3$ is used. If 8PSK $3/4$ mode is used for the broadcasting service, this represent a link margin of approximately 1 dB on the smallest broadband terminals. Should 1 dB link margin be deemed insufficient, the employment of 8PSK $2/3$ instead would increase the link margin to approximately 2.4 dB. Which mode to use for the broadcasting service is dependent on the antenna diameter selected for the small broadband terminals supporting service levels A and B.

Distress and safety services are typically low rate services, but with very high availability requirements. Such a service provided through a HEO satellite system to the Arctic, should utilize the most robust coding and modulation mode defined by DVB-S2 on the forward link. A carrier using the QPSK $1/4$

mode can in clear sky conditions be received by an antenna with a diameter of only 15 cm for both the K_u and K_a band cases. However, because of the high availability requirements a larger antenna diameter should be used to ensure connectivity also in extreme and foul weather. An antenna diameter of 32 cm would provide a link margin of 6.4 dB. Increasing the size further up to 34 cm would improve the link margin to 7.0 dB. At these antenna dimensions the forward link performance is the same in the K_u and K_a bands. User terminals for distress and safety services should have an antenna diameter of at least 32 cm to ensure the necessary link availability. An analysis of the return link environment is necessary to assure that is an appropriate antenna dimension.

8.3 Return link

Link budgets can also be established for the return link with basis in the system parameters discussed in the previous chapters and the gateway parameters considered in this chapter. As for the forward link budget, only information on the earth stations and user terminals are undefined in the return link budget. All variables part of the return downlink budget, transmission from satellite to gateway, have been defined. A link budget for the return downlink can be put together. Table 8.5 presents a version for clear sky conditions and with a channel bandwidth of 1 MHz.

The return downlink carrier to noise density ratio, C/N_{oRD} , is dependent on the channel bandwidth. Assuming a uniform distribution of power across the satellite transponder bandwidth, the transmitted power per channel will increase with a higher channel bandwidth. The 1 MHz channel bandwidth used in the link budget shown in Table 8.5, results in a C/N_{oRD} of 98.0 dB Hz in the K_u band case and 103.4 dB Hz in the K_a band case. With a 2 MHz channel, C/N_{oRD} increase by 3.0 dB while for 3 MHz and 6 MHz the increase is 4.8 dB and 7.8 dB, respectively.

The return uplink budget requires information about the earth stations or user terminals for completion. The other components of the return uplink budget are listed in Table 8.6. Based on these parameters it is possible to evaluate the performance requirements of earth stations and user terminals necessary for the provision of the various services suggested in section 2.4. In Figure 8.6 estimates of the overall carrier to noise density ratio, C/N_{oR} , are shown for both the K_u and K_a bands as a function of earth station EIRP.

The results displayed in Figure 8.6 assume clear sky conditions, and combines

Table 8.5: Clear sky link budget for the return downlink on both K_u and K_a band.

Parameter		K_u band	K_a band	Unit
<i>Satellite</i>				
Feeder link transmit power	P_{FL}	16.0	19.0	dB W
Transponder bandwidth		36.0	36.0	MHz
Channel bandwidth	B_{ch}	1.0	1.0	MHz
Feeder link power per channel	P_{FLch}	0.4	3.4	dB W
Feeder network loss	L_{FN}	1.5	1.5	dB
Feeder link antenna gain	G_{FL}	40.9	40.8	dB
Satellite EIRP per channel	$EIRP_{Sch}$	39.8	42.7	dB W
<i>Propagation</i>				
Free space loss	L_{FSL}	205.5	210.7	dB
Atmospheric attenuation	L_{PL}	0.1	0.6	dB
<i>Gateway</i>				
Gateway downlink gain	G_{gd}	56.3	66.8	dB
Receive system noise temperature	T_s	20.4	22.8	dB K
Boltzmann constant	k	-228.6	-228.6	dB W s/K
<i>Downlink result</i>				
Carrier to noise density ratio	C/N_{oRD}	98.0	103.2	dB Hz

Table 8.6: Summary of clear sky link budget parameters for the return uplink on both K_u and K_a band.

Parameter		K_u band	K_a band	Unit
<i>Propagation</i>				
Free space loss	L_{FSL}	207.6	213.9	dB
Atmospheric attenuation	L_{PL}	0.2	0.6	dB
<i>Satellite</i>				
Edge of beam loss	L_{EOB}	3.0	3.0	dB
Uplink antenna gain	G_{UL}	32.1	32.1	dB
Receive system noise temperature	T_{sat}	25.6	26.2	dB K
Boltzmann constant	k	-228.6	-228.6	dB W s/K

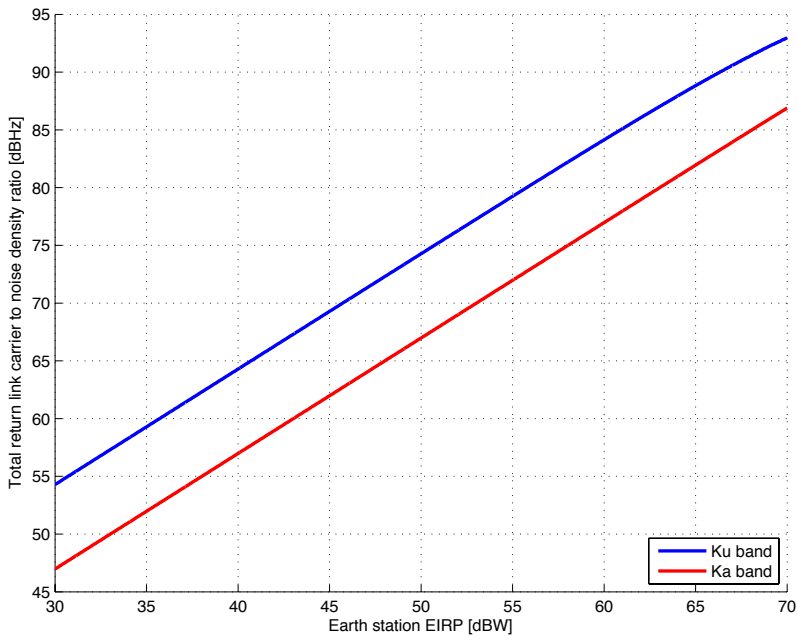

Figure 8.6: Overall return link carrier to noise density ratio as a function of earth station EIRP.

both uplink and downlink of the return link. For typical earth station and user terminal EIRP levels, the uplink carrier to noise density, C/N_{oRU} , is significantly lower than C/N_{oRD} . As a result, C/N_{oR} will be dominated by the uplink signal strength. Given that the channel bandwidth only changes C/N_{oRD} , it has a limited impact on the overall carrier to noise density ratio for relevant earth station EIRP values. The estimates of C/N_{oR} are for a channel bandwidth of 1 MHz. A wider channel bandwidth will give only slightly improved C/N_{oR} at high earth station EIRP values.

A similar procedure as the one used on the forward link to find possible bit rates as a function of earth station antenna diameter is also applicable on the return link. For broadband and distress and safety services, the intention is to use DVB-RCS2 while DVB-S2 is chosen for backhaul services. Possible bit rates for the different coding and modulation modes defined by DVB-RCS2 and DVB-S2 can be calculated by combining the spectral efficiency and error performance of the different modes with C/N_{oR} estimates as those shown in Figure 8.6. The results for the 10 modes defined by DVB-RCS2, and available in the broadband services, are shown in Figure 8.7 with a 2 MHz channel bandwidth. Figure 8.8 shows results in the same manner for the

backhaul services with the 28 modes defined by DVB-S2 and a 6 MHz channel bandwidth.

In the sloping sections, the corresponding earth station EIRP results in a power limited bit rate and is given by equation 8.1. When the earth station EIRP is high enough the maximum possible bit rate becomes bandwidth limited and is given by equation 8.2, where the transponder bandwidth, B_C , is replaced by the channel bandwidth, B_{ch} . This corresponds to the horizontal sections in Figure 8.7 and 8.8.

It should be possible to provide the different broadband service levels on the same channels. Such a solution will allow for an efficient and flexible utilization of satellite resources. Various earth station types supporting different service levels will not have the same capabilities, and, therefore, transfer data at different bit rates. However, they should transmit with the same symbol rate to ensure compatible operations. If this common symbol rate is chosen to correspond to the bandwidth limited scenario of the different coding and modulation modes, it will allow for maximum utilization of the satellite capacity. Earth stations for backhaul services will use individual channels. Thus, in theory it could adjust the symbol rate according to the signal environment to ensure the highest possible bite rates. However, a fixed symbol rate also for the backhaul services will simplify the system architecture, and allow for easier synchronization between a gateway and the remote earth station.

From Figure 8.7, it can be observed that the most efficient DVB-RCS2 coding and modulation mode allow a bit rate of almost 5 Mbit/s to be transferred over a 2 MHz channel. This indicate that channel bandwidths of 1 MHz and 2 MHz are appropriate for the service levels suggested in section 2.4. In section 7.10, it was suggested to use channel bandwidths of 6 MHz and 3 MHz for the two backhaul service levels. Based on these channel bandwidths the maximum throughput for the various coding and modulation modes can be calculated as a function of earth station EIRP. The potential broadband bit rates are shown in Figure 8.9 while Figure 8.10 display potential backhaul bit rates.

The results provided in Figure 8.9 and 8.10 can be used to establish nominal coding and modulation modes for the various broadband and backhaul service levels. A return link speed of 4 Mbit/s as stipulated in section 2.4 for broadband service level D, requires a 2 MHz channel and the use 16QAM modulation with a code rate of either $5/6$ or $3/4$. The other broadband service levels will be more efficiently served using a 1 MHz channel. While service level C should use 16QAM $5/6$, service level A and B can take advantage of a more robust mode for reduced earth station EIRP requirements.

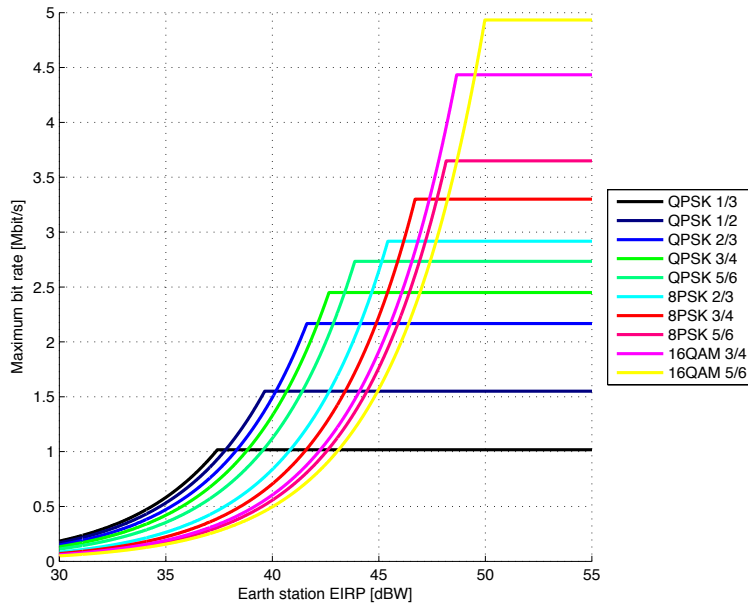

(a) K_u band

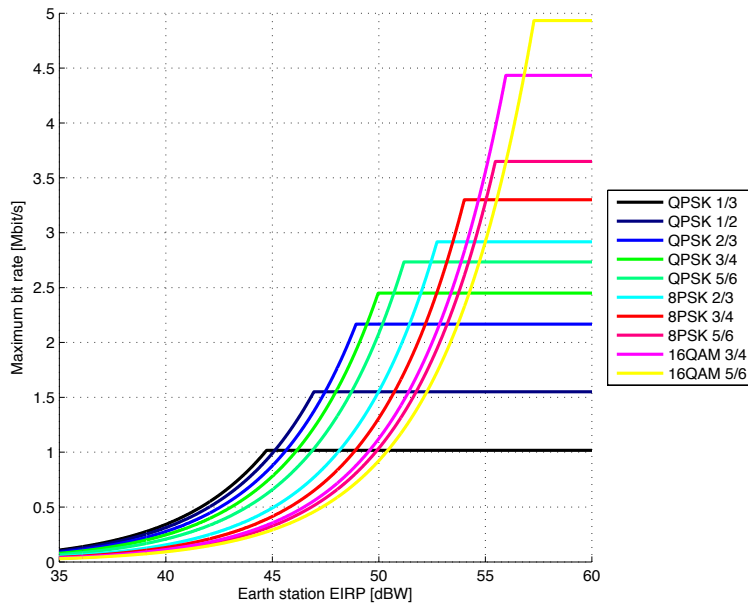

(b) K_a band

Figure 8.7: Possible broadband service bit rates for the different coding and modulation modes defined by DVB-RCS2 as a function of earth station EIRP for both the K_u and K_a band case with a channel bandwidth of 2 MHz.

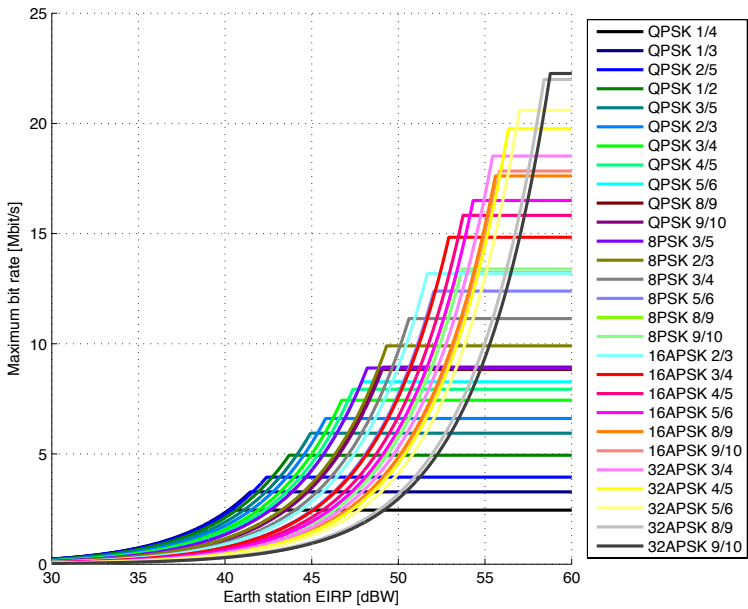

(a) K_u band

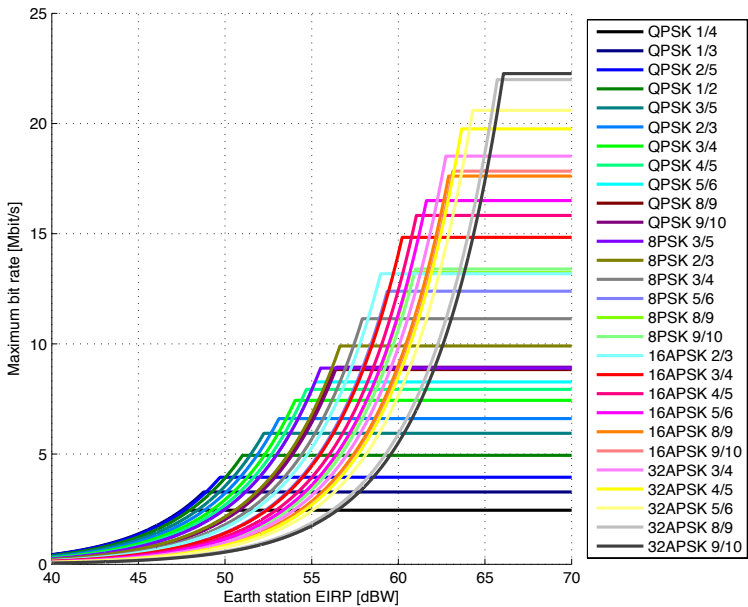

(b) K_a band

Figure 8.8: Possible backhaul service bit rates for the different coding and modulation modes defined by DVB-S2 as a function of earth station EIRP for both the K_u and K_a band casewith a channel bandwidth of 6 MHz.

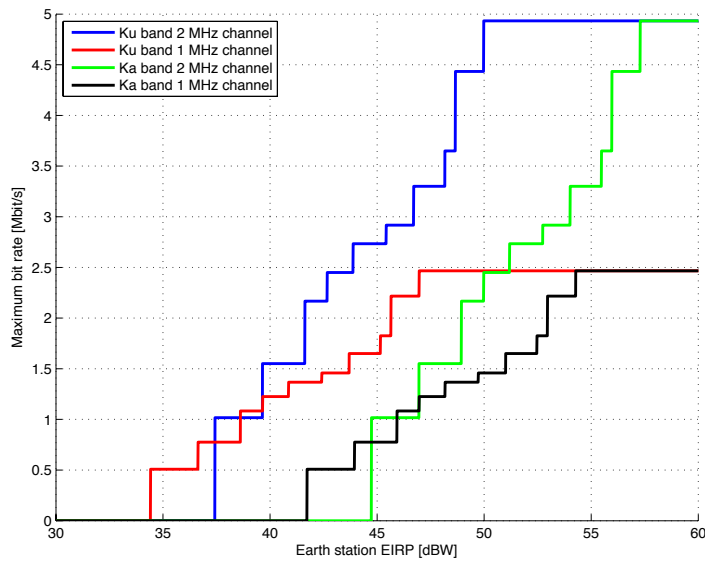

Figure 8.9: Maximum channel bit rates for the two broadband channel bandwidths as a function of earth station EIRP for both K_u and K_a band. Clear sky conditions are assumed, and the different steps indicate the different coding and modulation modes of DVB-RCS2.

As the backhaul service employs DVB-S2, it can support a bit rate of 22.2 Mbit/s on a 6 MHz channel and 11.1 Mbit/s on a 3 MHz channel. Such bit rates require the most efficient coding and modulation mode, $32\text{APSK } 9/10$. However, for support of the return link speed suggested for the backhaul services in section 2.4 $32\text{APSK } 5/6$ can be used. $32\text{APSK } 5/6$ have a reduced earth station EIRP requirement which allow for smaller antennas and reduced transmission power. These reduced earth station requirements might be worth the lower channel capacity. This is a trade-off that should be considered.

It is advantageous to translate the EIRP requirements into antenna diameter and transmit power. For all the coding and modulation modes with accompanying bit rates shown in Figure 8.9 and 8.10, a minimum earth station EIRP requirement can be calculated. This would then be the EIRP necessary for support of the various coding and modulation modes with the different channel bandwidths in clear sky conditions. The earth station EIRP is a combination of transmitting power and antenna gain. At a fixed EIRP value, an increase in transmitting power allows for a decrease in antenna gain and diameter, and vice versa. How transmitting power and antenna diameter are combined to ensure high enough earth station EIRP to support the various service levels,

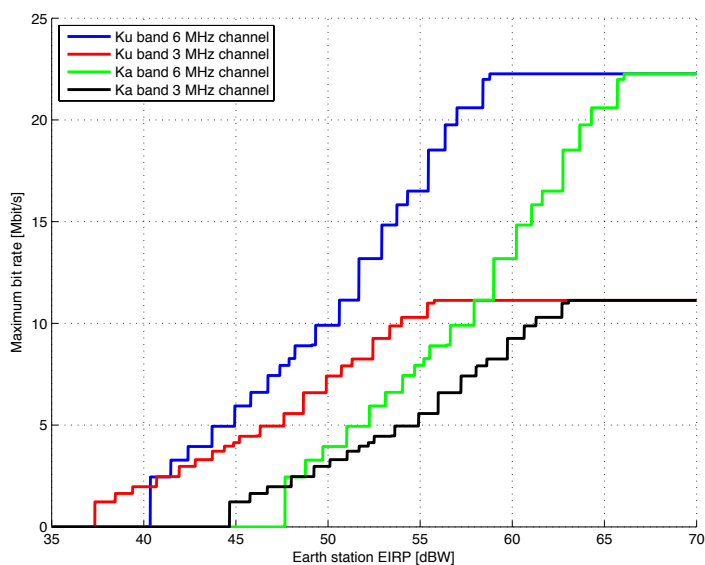
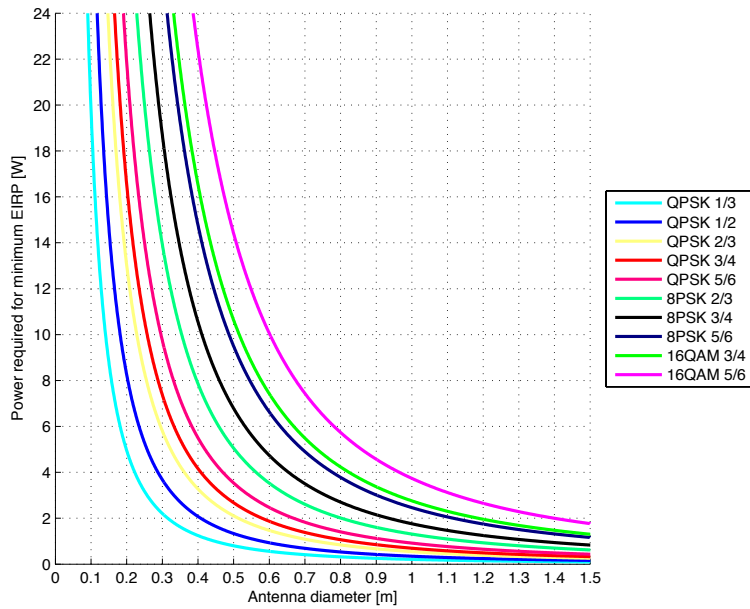

Figure 8.10: Maximum channel bit rates for the two backhaul channel bandwidths as a function of earth station EIRP for both K_u and K_a band. Clear sky conditions are assumed, and the different steps indicate the different coding and modulation modes of DVB-S2.

is, therefore, an important trade-off when designing earth stations for satellite communications systems. Figure 8.11 and 8.12 indicate combinations of transmitting power and antenna diameter which provide an EIRP level necessary for support of the different DVB-RCS2 modes used for the broadband service. Similar illustrations for the backhaul service are provided in Figure 8.13 and 8.14 for the various DVB-S2 modes. In the results given for the broadband services, antenna pointing loss is taken into account. For the backhaul service, it is assumed that the earth stations are more advanced and have a higher antenna pointing accuracy. Hence, antenna pointing loss is not taken into account in the calculations for backhaul services.

From Figure 8.11 to 8.14, it can be observed that the transmitting power is very low with large antennas. A high transmitting power, on the other hand, allows the use of small antennas. The key issue is to identify where the optimal combinations of transmit power and antenna diameter can be found. First note the extreme values where the antenna diameter is large or the transmitting power is high. With a large antenna diameter, even a small increase in transmitting power provides the possibility for significant reduction in antenna diameter. At a high transmitting power, a small increase



(a) 1 MHz channel bandwidth

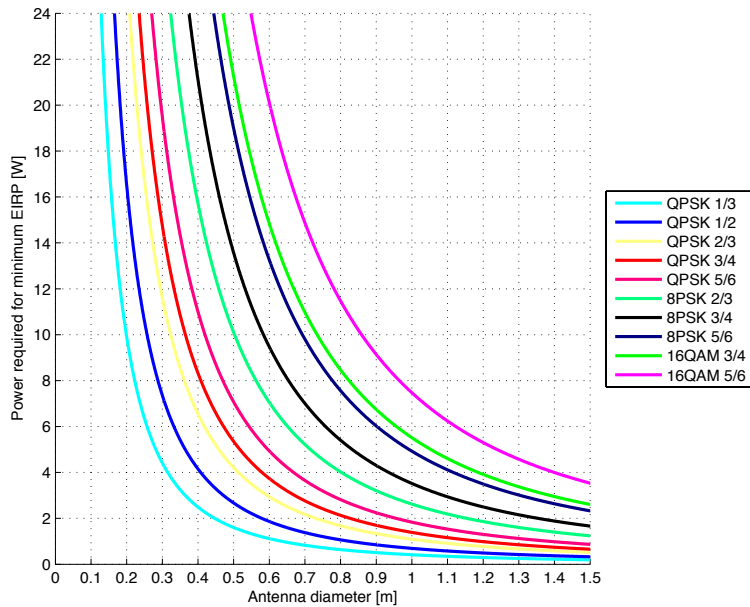

(b) 2 MHz channel bandwidth

Figure 8.11: Combinations of earth station antenna diameter and transmitting power providing the EIRP necessary to support the different DVB-RCS2 modes on 1 MHz and 2 MHz broadband service channels for the K_u band case.

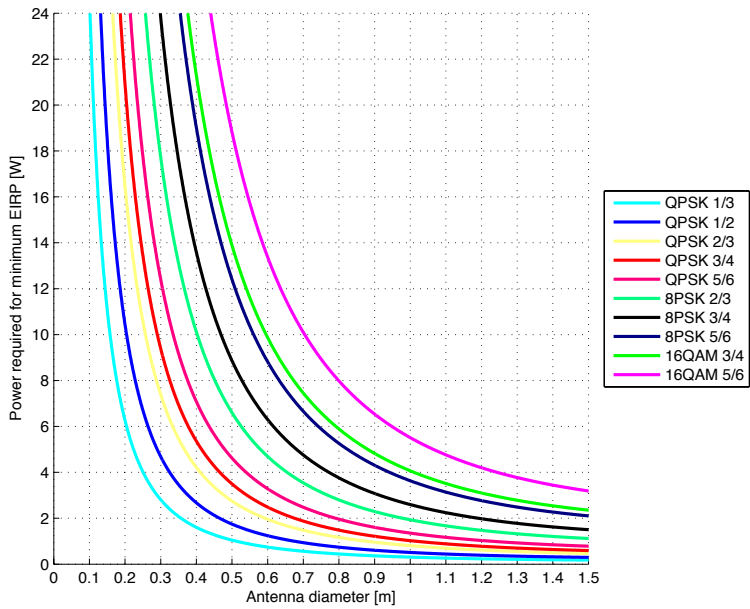

(a) 1 MHz channel bandwidth

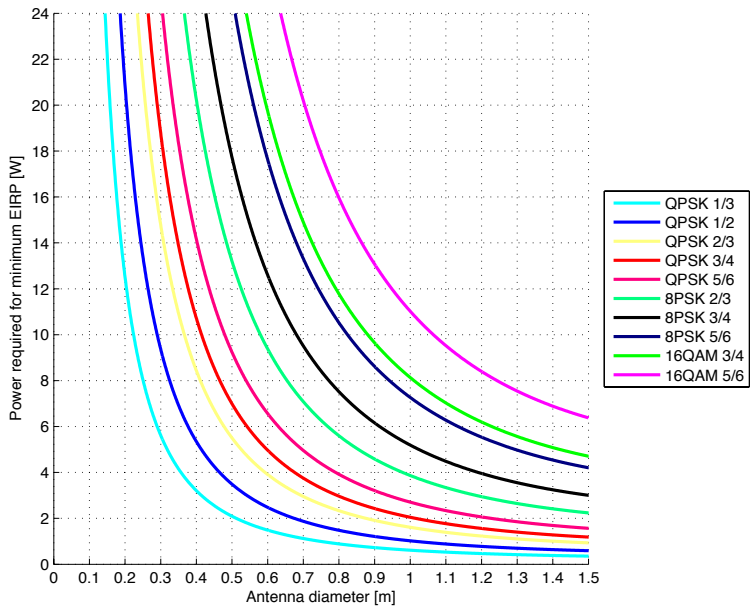

(b) 2 MHz channel bandwidth

Figure 8.12: Combinations of earth station antenna diameter and transmitting power providing the EIRP necessary to support the different DVB-RCS2 modes on 1 MHz and 2 MHz broadband service channels for the K_a band case.

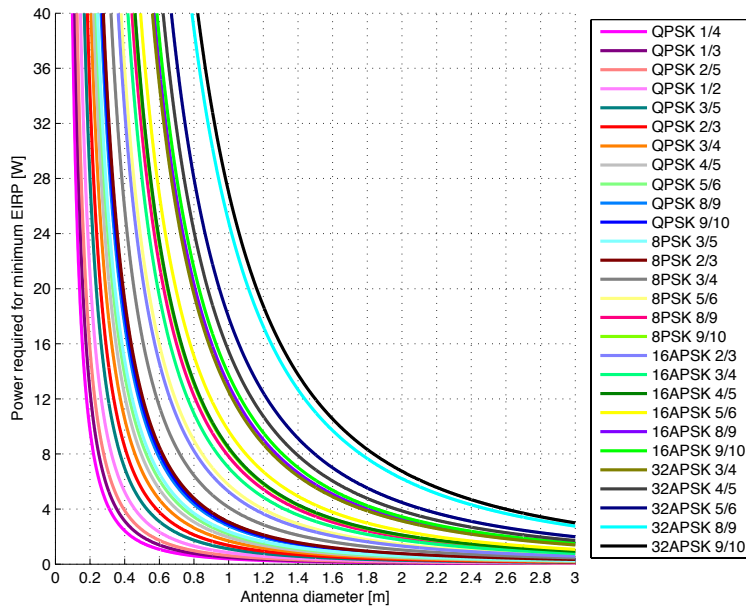

(a) 3 MHz channel bandwidth

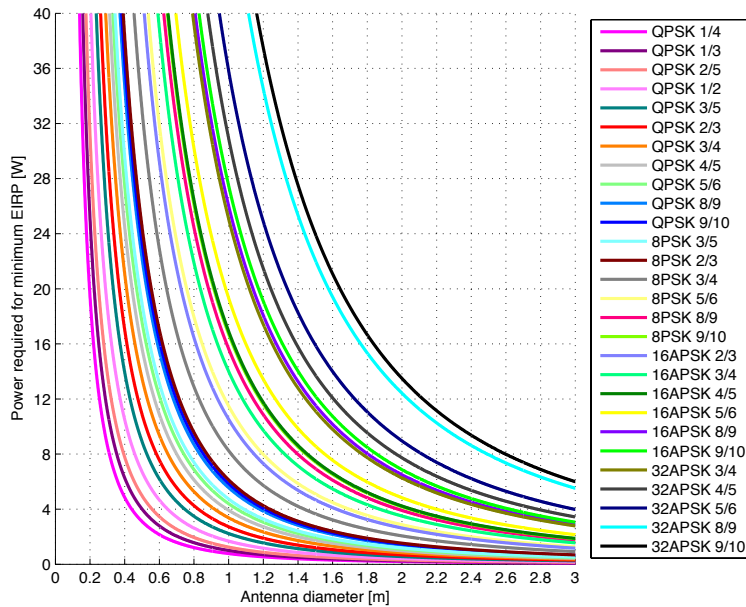

(b) 6 MHz channel bandwidth

Figure 8.13: Combinations of earth station antenna diameter and transmitting power providing the EIRP necessary to support the different DVB-S2 modes on 3 MHz and 6 MHz backhaul service channels for the K_u band case.

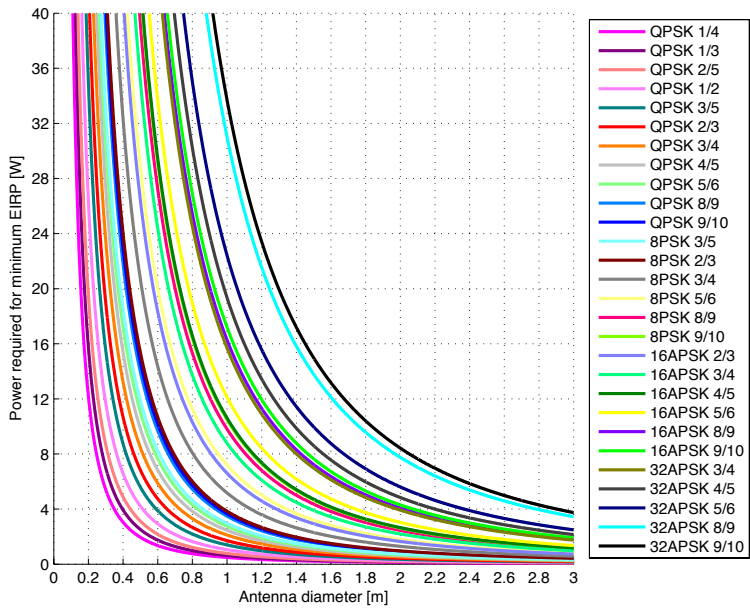

(a) 3 MHz channel bandwidth

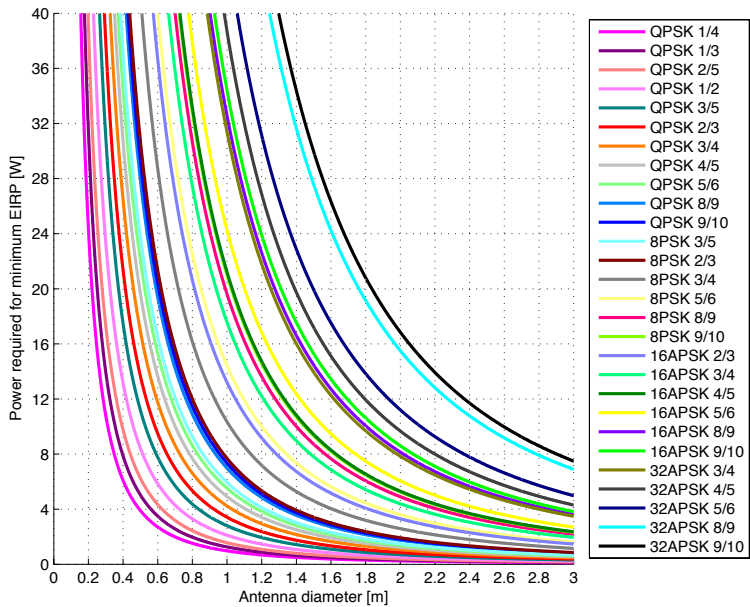

(b) 6 MHz channel bandwidth

Figure 8.14: Combinations of earth station antenna diameter and transmitting power providing the EIRP necessary to support the different DVB-S2 modes on 3 MHz and 6 MHz backhaul service channels for the K_a band case.

in antenna diameter allows for significantly reduced transmitting power. An ideal combination of transmitting power and antenna gain should lie in a region where changes in transmitting power and antenna diameter carry equal weight. It is assumed that this region can be found in Figure 8.11 to 8.14 where the lines curve the most.

Based on this assumption it is possible to calculate the optimal combination of transmitting power and antenna diameter for a given EIRP level. However, this is very difficult as it requires appropriate scaling of the effect the two parameters have in terms of cost, weight and system complexity. The appropriate combination is also highly dependent on the performance of components available and in current use. Therefore, it is assumed better to analyze the results and define a range where antenna diameter and transmit power should result in close to optimal performance. These ranges can then be compared with the results from the analysis of the forward link, and be used to narrow down the design space for the earth stations and user terminals.

Selection of appropriate coding and modulation mode for the different broadband service levels is based on the results displayed in Figure 8.11 and 8.12. When analyzed in conjunction with potential bit rates supported by the various modes, as shown in Figure 8.9, it is possible to determine the most appropriate mode for a service level. The ranges for optimal antenna diameter and transmit power can then be identified for services based on the coding and modulation mode selected. This exercise can also be done for the backhaul and distress and safety services. In Table 8.7, suggested antenna diameter and transmit power ranges for the different service levels are listed together with the coding and modulation mode assumed to be most appropriate. Channel bandwidth and instantaneous bit rates are also provided.

Multiple broadband service users should share a 1 MHz channel. Sharing of a channel requires an instantaneous bit rate which is higher than the nominal uplink speed of 0.5 Mbit/s proposed in section 2.4. For service level A, an instantaneous bit rate about three times higher than the overall bit rate is assumed. On a 1 MHz channel, a bit rate slightly under 1.5 Mbit/s can be provided with QPSK $5/6$ and 8PSK $2/3$. The 8PSK $2/3$ mode supports a slightly higher bit rate, but the difference is less than 0.1 Mbit/s . Difference in required earth station EIRP is, however, significant. QPSK $5/6$ can be supported with about 1.6 dB lower EIRP, and should be used for the provision of broadband service level A. Suitable antenna diameters and transmit powers for broadband service level A are given in Table 8.7.

The suggested uplink speed for broadband service level B can be supported

Table 8.7: Summary of nominal coding and modulation mode with instantaneous channel bit rate, R_b , suggested for the return link of various services in clear sky conditions. The ranges for optimal antenna diameter and transmit power necessary to support this mode is also provided, along with channel bandwidth, B_{ch} , and resulting instantaneous bit rate, R_b .

Service	Mode	B_{ch} [MHz]	R_b [Mbit/s]	EIRP requirement		Antenna diameter		Transmit power	
				K_u [dB W]	K_a [dB W]	K_u [m]	K_a [m]	K_u [W]	K_a [W]
Broadband A	QPSK $5/6$	1.0	1.4	40.9	48.2	0.4 - 0.6	0.4 - 0.7	5.5 - 2.5	7.1 - 2.5
Broadband B	8PSK $3/4$	1.0	1.7	43.7	51.0	0.5 - 0.7	0.5 - 0.8	6.8 - 3.5	8.9 - 3.8
Broadband C	16QAM $5/6$	1.0	2.5	47.0	54.3	0.6 - 1.0	0.7 - 1.0	10.1 - 3.7	10.1 - 5.5
Broadband D	16QAM $5/6$	2.0	4.9	50.0	57.3	0.8 - 1.2	0.9 - 1.3	11.5 - 5.3	13.1 - 7.5
Backhaul A	32APSK $5/6$	6.0	20.6	57.0	64.3	1.5 - 2.2	1.6 - 2.3	15.9 - 7.4	17.5 - 8.5
Backhaul B	32APSK $5/6$	3.0	10.3	54.0	61.3	1.1 - 1.8	1.2 - 2.0	14.8 - 5.5	15.6 - 5.6
Distress and safety	QPSK $1/3$	1.0	0.5	34.4	41.7	0.2 - 0.4	0.2 - 0.4	4.9 - 1.2	6.2 - 1.6

with the same modulation and coding mode as service level A. However, for more efficient utilization of satellite capacity it is reasonable to demand a higher performance from level B earth stations. As the intention is to use 16QAM $5/6$ for service level C, it is natural to select a coding and modulation mode somewhere between that of service level A and C. Thus, 8PSK modulation should be used with a code rate of either $3/4$ or $5/6$. On a 1 MHz channel 8PSK $5/6$ provides an instantaneous bit rate of about 1.8 Mbit/s . That is less than 0.2 Mbit/s more than 8PSK $3/4$, but still requires an earth station EIRP which is about 1.5 dB higher. Therefore, 8PSK $3/4$ has been selected as the nominal coding and modulation mode for broadband service level B. Ranges for optimal antenna diameter and transmitting power are provided in Table 8.7. The antenna diameter range is 0.1 m higher than for service level A while the transmitting power range is between 1 W and 2 W higher.

Broadband service level C should utilize a 1 MHz channel with 16QAM $5/6$ as modulation and coding mode. That is, as discussed above, the most efficient way to provide the 2 Mbit/s uplink speed. With an instantaneous bit rate of 2.47 Mbit/s this solution do not allow a high degree of channel sharing. Nevertheless, it is the preferred choice. Ranges for antenna diameter and transmitting power where their combination is assumed to be optimal, are given in Table 8.7 for broadband service level C as well.

The only broadband service that will use a 2 MHz channel, is level D. With 16QAM $5/6$ a bit rate of about 4.9 Mbit/s can be transferred. The suggested uplink speed of 4 Mbit/s can also be met by 16QAM $3/4$. However, for optimal service provision, 16QAM $5/6$ is selected for nominal operations. This coding and modulation mode requires a high performance earth station, but the antenna diameter and transmit power ranges listed in Table 8.7 are reasonable for the suggested bit rates.

For backhaul services, the earth station EIRP requirement can be reduced by 1.7 dB if 32APSK modulation is used in combination with a code rate of $5/6$ instead of $9/10$. Uplink speeds of 10 Mbit/s and 20 Mbit/s can still be provided. At the relevant performance level, an EIRP reduction of 1.7 dB can be transformed into noticeable smaller antennas and lower power levels. Thus, it is recommended utilizing 32APSK $5/6$ for both backhaul service level A and B. Table 8.7 provides the ranges of appropriate antenna diameter and transmitting power.

A distress and safety service should use the most robust coding and modulation mode and incorporate a significant link margin. This is necessary to ensure adequate availability for such a service. For both the K_u and K_a bands, an

antenna diameter between 0.2 m and 0.4 m is assumed to be the optimal range. The transmitting power required to produce the necessary EIRP for support of QPSK $1/3$ is given in Table 8.7. However, to ensure adequate link margins, the transmit power level should be significantly higher than those values.

This analysis of the return link and results given in Table 8.7 must be combined with the results from the forward link analysis summarized in Table 8.4. Antenna dimensions and power requirements for earth stations supporting the various services can then be deduced. The following sections address this and consider the key parameters for earth station design and performance.

8.4 Discussion of earth station parameters

Based on the forward and return link analysis of the previous sections, appropriate earth station parameters can be selected for the various services. The performance of the different service levels in terms of bit rates and link margin can then be calculated. For the K_u band case the findings are summarized in Table 8.8, while Table 8.9 provide the parameters and performance for the K_a band case. In the following sections, each service is considered and discussed separately.

8.4.1 Broadband services

A broadband service is a two way interactive service. Thus, both the forward and return link have an influence on earth station design. Minimum antenna diameters were established for the provision of the four broadband service levels in the forward link analysis. The return link analysis produced ranges of suitable antenna diameter and transmitting power. For all the four broadband service levels, the range of suitable antenna diameter extends below the minimum value found in the forward link analysis and provided in Table 8.4. Therefore, the full antenna diameter ranges identified in the return link analysis and listed in Table 8.7 do not represent a dimensioning case.

Users of satellite communications typically prefer earth station antennas to be as small as possible. Small antennas are easier to accommodate and have a less complex installation procedure. This is especially important for mobile maritime and aeronautical users. Thus, earth station antennas should target the minimum diameter that can support the desired service level. A possible show stopper for a smaller earth station antenna is a higher transmitting power

Table 8.8: Summary of earth station specifications and service performance for the K_u band case. In the table d is antenna diameter, CMM_f is the nominal forward link coding and modulation mode for clear sky conditions, R_f is the forward link instantaneous bit rate, M_f is margin on the forward link, CMM_r is the nominal return link coding and modulation mode for clear sky conditions, B_{ch} is the channel bandwidth of the return link, R_r is the return link instantaneous bit rate, P_{ES} is earth station transmit power and M_r is the margin on the return link.

Service	d [m]	CMM_f	R_f [Mbit/s]	M_f [dB]	CMM_r	B_{ch} [MHz]	R_r [Mbit/s]	P_{ES} [W]	M_r [dB]
Broadband A	0.60	16APSK $2/3$	79.1	0.6	QPSK $5/6$	1.0	1.4	3.0	0.9
Broadband B	0.60	16APSK $2/3$	79.1	0.6	8PSK $3/4$	1.0	1.7	5.0	0.2
Broadband C	0.90	32APSK $3/4$	111.1	0.3	16QAM $5/6$	1.0	2.5	5.0	0.4
Broadband D	1.30	32APSK $9/10$	133.6	0.0	16QAM $5/6$	2.0	4.9	5.0	0.4
Backhaul A	1.60	32APSK $9/10$	133.6	2.0	32APSK $5/6$	6.0	20.6	15.0	0.3
Backhaul B	1.30	32APSK $9/10$	133.6	0.2	32APSK $5/6$	3.0	10.3	11.0	0.2
Distress and safety	0.35	QPSK $1/4$	14.7	7.2	QPSK $1/3$	1.0	0.5	7.0	6.4
Broadcast	0.60	8PSK $3/4$	66.8	1.6					

Table 8.9: Summary of earth station specifications and service performance for the K_a band case. In the table d is antenna diameter, CMM_f is the nominal forward link coding and modulation mode for clear sky conditions, R_f is the forward link instantaneous bit rate, M_f is margin on the forward link, CMM_r is the nominal return link coding and modulation mode for clear sky conditions, B_{ch} is the channel bandwidth of the return link, R_r is the return link instantaneous bit rate, P_{ES} is earth station transmit power and M_r is the margin on the return link.

Service	d [m]	CMM_f	R_f [Mbit/s]	M_f [dB]	CMM_r	B_{ch} [MHz]	R_r [Mbit/s]	P_{ES} [W]	M_r [dB]
Broadband A	0.60	16APSK $2/3$	79.1	0.5	QPSK $5/6$	1.0	1.4	4.0	0.9
Broadband B	0.60	16APSK $2/3$	79.1	0.5	8PSK $3/4$	1.0	1.7	7.0	0.5
Broadband C	0.90	32APSK $3/4$	111.1	0.0	16QAM $5/6$	1.0	2.5	7.0	0.3
Broadband D	1.40	32APSK $9/10$	133.6	0.0	16QAM $5/6$	2.0	4.9	7.0	0.1
Backhaul A	1.80	32APSK $9/10$	133.6	2.9	32APSK $5/6$	6.0	20.6	15.0	0.4
Backhaul B	1.40	32APSK $9/10$	133.6	0.8	32APSK $5/6$	3.0	10.3	12.0	0.2
Distress and safety	0.35	QPSK $1/4$	14.7	7.2	QPSK $1/3$	1.0	0.5	9.0	6.4
Broadcast	0.60	8PSK $3/4$	66.8	1.5					

requirement. However, the transmitting power figures found in Table 8.7 are all deemed to be technically feasible. Based on these considerations it is deemed appropriate to use earth station antenna diameters close to the minimum values found in the forward link analysis.

The K_u band case

For the K_u band case, it is suggested to use 60 cm antennas for broadband service level A and B. This is a slightly larger antenna diameter than that indicated in Table 8.4, but the increased diameter has a positive effect on the transmitting power requirement without being too large. A 60 cm K_u band antenna supports the use of 16APSK $2/3$ with an instantaneous bit rate of 79.1 Mbit/s on a 36 MHz carrier with a link margin of 0.6 dB. On the return link, a transmitting power of 3 W will support an instantaneous bit rate of about 1.4 Mbit/s on a 1 MHz channel using QPSK $5/6$. An earth station transmitting power of 5 W supports an instantaneous bit rate of about 1.7 Mbit/s on the same channel using 8PSK $3/4$. The 3 W option is specified for service level A while an earth station transmitting power of 5 W is for service level B. These two services will have clear sky link margins of 0.9 dB and 0.2 dB for service level A and B, respectively.

Users of broadband service level C should be fitted with a 90 cm antenna. This is 3 cm larger than the minimum diameter identified in the forward link analysis. An instantaneous bit rate of about 111.1 Mbit/s can be transferred, if 32APSK $3/4$ is employed, on a 36 MHz forward link carrier. Forward link margin for service level C in this case is 0.3 dB. A 1 MHz channel return link with 16QAM $5/6$ providing an instantaneous bit rate of approximately 2.5 Mbit/s , is supported with an earth station transmitting power of 5 W. Such a return link will have a margin of 0.4 dB.

An earth station antenna diameter of 130 cm is deemed appropriate for broadband service level D in the K_u band case. Such an antenna will permit the use of the most efficient DVB-S2 coding and modulation mode, 32APSK $9/10$. A 36 MHz forward link carrier can then provide an instantaneous bit rate as high as 133.6 Mbit/s , but without any link margin. For the return link, a 2 MHz channel using 16QAM $5/6$ should be employed to support a bit rate of about 4.9 Mbit/s . An earth station transmitting power of 5 W is necessary and results in a clear sky link margin of 0.4 dB. The parameters and performance of the four broadband service levels is provided for the K_u band case in Table 8.8.

It is important to note, that the ITU regulations stipulate limitations on an-

tenna diameter for mobile user terminals in the K_u band. A minimum antenna diameter of 1.2 m is required for GEO based satellite systems. Smaller antennas can be used if interference reducing measures, such as spread spectrum techniques, are employed [34]. However, it is assumed not to be relevant for this study. As long as the criteria for operations on a non-interfering basis with GEO satellites are met, smaller antennas are assumed to be allowed for use in HEO based satellite systems. This assumption needs to be verified.

Regardless of the outcome of such a verification process, user terminals for roaming between HEO and GEO will have to adhere to these stipulations. Only user terminals specified for broadband service level D is compliant with the 1.2 m antenna diameter requirement. Thus, in a K_u band system with the earth station parameters and performance as suggested in Table 8.8, only broadband service level D is applicable to users requiring roaming between GEO and HEO. Alternatively, the return link performance of service level A, B and C could be provided with reduced earth station transmitting power on a 1.2 m antenna. The required earth station transmitting power would then be less than 1 W, 1.5 W and 3 W for service levels A, B and C, respectively.

The K_a band case

Also in the K_a band case, it is suggested to employ 60 cm antennas for support of broadband service level A and B. This is 3 cm larger than the minimum antenna diameter identified during the forward link analysis, and adequate for support of 16APSK $2/3$ as coding and modulation mode. The instantaneous bit rate of about 79.1 Mbit/s on the 36 MHz forward link carrier is, therefore, the same as for the K_u band alternative. A link margin of 0.5 dB is expected. Service level A employing QPSK $5/6$ on a 1 MHz channel return link supports an instantaneous bit rate of about 1.4 Mbit/s . With an earth station transmitting power of 4 W the link margin is 0.9 dB. 8PSK $3/4$ used on the same channel provide a transmission speed of 1.7 Mbit/s . A service level B user terminal with a 7 W transmitting power can support this with a link margin of 0.5 dB.

A 90 cm user terminal antenna is found to be reasonable in the K_a band case for broadband service level C. This is the minimum antenna diameter for use of 32APSK $3/4$ on the 36 MHz forward link carrier. Such a link can transfer 111.1 Mbit/s , but without any link margin. The service level C return link should employ 16QAM $5/6$ on a 1 MHz channel. An earth station transmitting power of 7 W will support a 2.5 Mbit/s return link speed with a link margin of 0.3 dB.

The last broadband service level require a user terminal antenna diameter of

at least 140 cm to provide the desired forward link bit rates. Based on that, a suitable antennas size for a service level D terminal is assumed to be 140 cm. Even though there is no link margin, service level D can then support a forward link instantaneous bit rate of almost 133.6 Mbit/s on a 36 MHz carrier using 32APSK $9/10$. On the return link, service level D use the same modulation and coding as service level C, 16QAM $5/6$, but to provide the uplink speed of 4.9 Mbit/s , a 2 MHz channel is used. An user terminal transmitting power of 7 W will then result in a clear sky link margin of 0.1 dB. All the specifications and performance figures for the K_a band broadband services and earth stations are summarized in Table 8.9.

8.4.2 Backhaul services

The forward link analysis concluded that the required backhaul service bit rates can be provided to earth stations with the same antenna dimensions as broadband service level D. However, because of the high return link bit rates required for the backhaul services, the earth stations must be more capable. For the backhaul service, it is deemed appropriate to use wider return channels compared to the broadband service. Also, DVB-RCS2 coding and modulation is replaced by DVB-S2 on the return link. It should be noted that backhaul service earth stations are expected to be fixed installations with accurate satellite tracking equipment. Therefore, the antenna pointing loss is assumed to be negligible and set to zero in the backhaul service link calculations.

The K_u band case

Backhaul service level A can be supported by a 160 cm antenna in the K_u band. Use of the same coding and modulation mode and the same carrier bandwidth as broadband service level D, result in the same instantaneous bit rate of close 133.6 Mbit/s . However, the larger antenna with no pointing loss will provide a 2.0 dB link margin on the forward link. The larger antenna is necessary for the provision of the desired return link bit rate of 20 Mbit/s . A higher earth station transmitting power is also required for support of such a bit rate. It is proposed to employ 32APSK $5/6$ on a 6 MHz channel to provide a return link transmission speed of about 20.6 Mbit/s . With a transmitting power of 15 W, such a return link will have a clear sky link margin of 0.3 dB.

The return link bit rate of backhaul service level B is specified to be half of that of service level A. As a result, the antenna diameter can be reduced for earth

stations providing this service. In the K_u band, the minimum antenna diameter able to support the use of the most efficient DVB-S2 coding and modulation mode on the forward link is 130 cm. Such an antenna can support a return link bit rate of 10.3 Mbit/s on a 3 MHz channel. The return link would then use 32APSK $5/6$ and require an earth station transmitting power of 11 W. A link margin of 0.2 dB is expected on such a link. Table 8.8 summarizes the findings for the two backhaul service levels. Note that the forward link margin for backhaul service level B is better than for broadband service level D even though the antenna diameter is the same. This difference is due to the assumed better pointing accuracy of backhaul service earth stations.

The K_a band case

The same argumentation used for the specification of the K_u band backhaul stations is applicable also in the K_a band case. For service level A the return link is the constraining factor on earth station antenna dimensioning. A return link transmission speed of 20.6 Mbit/s provided on a 6 MHz channel requires an antenna diameter of 180 cm and transmitting power of 15 W. With 32APSK $5/6$ the return link then have a 0.4 dB link margin. A 180 cm antenna supports the maximum forward link bit rate with a link margin of 2.9 dB.

Backhaul service level B will use the same 140 cm antenna diameter as broadband service level D in the K_a band case. Therefore, the forward link speed will be the same, but the negligible antenna pointing error assumed for backhaul service earth stations results in a better link margin of 0.8 dB. On the return link, a 3 MHz channel employing 32APSK $5/6$ will provide the necessary 10.3 Mbit/s . Support of such a return link requires an earth station transmitting power of 12 W. A link margin of 0.2 dB is then expected. The backhaul service specifications and performance figures are provided in Table 8.9.

8.4.3 Broadcasting services

A broadcasting service is not interactive. Therefore, it consists only of a forward link so broadcasting user terminals can be designed to receive only. Without the constraints of a return link, earth station parameters can be chosen more freely. In the forward link analysis, it was suggested to use 8PSK modulation with code rates of either $3/4$ or $2/3$. Given the assumed system parameters, this allows an adequate throughput with some link margin to the user terminal antennas with diameters of 56 cm in the K_u band and 57 cm

in the K_a band. Based on these findings it is recommended to standardize the broadcasting service for 60 cm antennas in both frequency bands. 8PSK $3/4$ can then provide a bit rate of about 66.8 Mbit/s on a 36 MHz carrier. The suggested antenna size will ensure clear sky link margins of 1.6 dB and 1.5 dB in the K_u and the K_a band, respectively. These values are summarized in Table 8.8 and 8.9.

The majority of broadcasting service users in the Arctic and high latitude areas is expected also to require broadband communications. Many of the earth stations receiving broadcast services will, therefore, be equipped with antennas larger than 60 cm for support of broadband or even backhaul services. Such users can in theory receive more content on the same bandwidth as they are capable of receiving at a higher bit rate. However, the cost effectiveness of broadcasting services lies in the same signal being receivable by a large number of users. Thus, the primary advantage when using earth stations designed for broadband or backhaul services to receive broadcasting services, is a higher link margin which provide a better service availability. As internet access is becoming equally important for entertainment as TV, the number of broadcasting receive only users may turn out to be low in the Arctic.

8.4.4 Distress and safety services

Reliability is crucial for a distress and safety service. High service availability requires a robust coding and modulation mode in combination with an appropriate link margin. The most robust coding and modulation mode defined by DVB-S2, QPSK $1/4$, should be used on the forward link. For the return link the most resilient mode defined by DVB-RCS2, QPSK $1/3$, should be applied. Typically, when in distress a user will not be able to operate the equipment as normal. Rough seas, bad weather or equipment malfunction, can significantly reduce the antenna pointing accuracy. Small antennas with a wide beamwidth can then be advantageous as the pointing loss will be limited even with large pointing errors. During the forward link analysis, antenna diameters of 32 cm and 34 cm were proposed as a minimum for distress and safety service equipment. The return link analysis found that an antenna diameter in this range also could serve the return link well. After considering appropriate link margins and necessary user terminal transmitting power, the distress and safety service specifications given in Table 8.8 and 8.9 were selected.

An antenna diameter of 35 cm is proposed for distress and safety services in the K_u band. On the forward link, such an antenna would allow an instantaneous

bit rate of about 14.7 Mbit/s to be received with a 7.2 dB link margin on a 36 MHz carrier. An earth station transmitting power of 1.6 W is necessary for support of a bit rate of approximately 0.5 Mbit/s on a 1 MHz return link channel. Substantial link margin is necessary also on the return link. Therefore, earth station transmitting power of 7 W is advisable for the K_u band distress and safety service. The link margin on the return link would then be 6.4 dB.

Also for the K_a band a user terminal antenna diameter of 35 cm is proposed for distress and safety services. The forward link bit rate of 14.7 Mbit/s is the same as for the K_u band and have a similar link margin of 7.2 dB. Channel bandwidth and bit rate are also the same as for the K_u band on the return link. A user terminal transmitting power of about 2.1 W is necessary to support such a return link with a 35 cm antenna in the K_a band. For adequate link margin, it is recommended to specify user terminals for distress and safety services with a transmitting power of 9 W. The K_a band transmitting power is slightly higher than advised for the K_u band case, but the link margin is approximately the same, 6.4 dB.

ITU regulations on minimum antenna diameter will also affect a distress and safety service. The proposed user terminal antenna dimension of 35 cm is far below the minimum 1.2 m stipulated for GEO based K_u band systems [34]. Similar constraints do currently not exist for K_a band systems, but can be imposed in the future. An exemption from the relevant regulations is expected to be necessary for the provision of services with such small antennas. However, such an exemption is conceivable given the very limited availability of adequate distress and safety services in the Arctic today. It should also be noted that this is mainly an issue for the return link.

8.5 Interference considerations

In the Radio Regulations issued by ITU, there are stipulations on interference from non-GEO satellite systems into GEO satellite systems. These stipulations are in the form of limits on Equivalent Power Flux Density (EPFD) radiated into a GEO satellite system. It includes both emissions from HEO earth stations into GEO and from HEO satellites into GEO earth stations. If the emissions into GEO systems from a HEO based satellite system are kept below these limits, frequency coordination with operators of GEO is not required. Thus, it is very advantageous if the HEO system is in compliance with the Equivalent Power Flux Density (EPFD) limits.

Procedures issued by the ITU have been used in a preliminary analysis of the interference environment created by the system studied here. Calculations indicate that the earth stations as they are specified here are not causing interference into GEO. In the K_u band case earth stations for broadband, backhaul and distress and safety services radiate into GEO a EPFD between -182.2 dBW/m^2 and -177.7 dBW/m^2 with a 40 kHz reference bandwidth. For the gateway the EPFD has been estimated to -208.0 dBW/m^2 . Calculations done for the K_a band case, indicate an EPFD radiated into GEO of between -185.2 dBW/m^2 and -176.6 dBW/m^2 for the user terminals and -212.5 dBW/m^2 for the gateway. In the Radio Regulations the maximum allowed uplink EPFD radiated into GEO is -160 dBW/m^2 in the K_u band and -162 dBW/m^2 in the K_a band. Thus, the uplinks of the HEO based satellite system studied here are well below the interference constraints set by ITU.

The EPFD radiated into GEO earth stations from the satellite downlink will not be absolutely constant. In section 7.5, it was claimed that the changes in free space loss will counteract the zooming effect of the satellite antenna beams and ensure a stable signal environment throughout the coverage area. This is only partly true. At the center of a spot beam, the signal strength will change as the free space loss changes, but at the beam edges the signal strength can be assumed to be almost constant. Estimates of the EPFD radiated into GEO earth stations should consider where the interference is the strongest. This is at the center of a spot beam, and will fluctuate as a satellite moves from the handover point to apogee and back to the handover point.

In the K_u band, the estimated EPFD radiated into an GEO earth station with the satellite at handover is -181.1 dBW/m^2 per 40 kHz. With the satellite at apogee, the EPFD reduces to -185.3 dBW/m^2 per 40 kHz. The calculations assumed a 60 cm reference antenna at the earth station positioned at 60° North and positioned at the center of a spot beam. On the downlink the EPFD limits stipulated by ITU are dependent on time. In the K_u band, the general limit is -175.4 dBW/m^2 , but for small percentages of the time it is allowed to exceed this level up to -160 dBW/m^2 . However, in the K_u band this time variation do not need to be considered as the estimated EPFD is well below the general limit.

For the K_a band case, the estimates of EPFD radiated into GEO earth stations are lower than in the K_u band. It is calculated to be -184.6 dBW/m^2 when a satellite is around handover, and to be -188.8 dBW/m^2 when a satellite is at apogee. In both cases the reference bandwidth is 40 kHz, and location of the earth station is assumed to be at the center of a spot beam at 60° northern

latitude. One difference between the K_a and the K_u band calculations was the earth station reference antenna specified by the ITU procedures. For the K_a band, a 70 cm reference antenna are used instead of a 60 cm reference antenna as was the case for the K_u band. The lower EPFD values estimated for the K_a band case when compared to the K_u band, should be a positive indication on the interference environment. However, for the K_a band the general EPFD value is significantly lower as it is set to -187.4 dBW/m^2 . Thus, there is a potential for a breach of the EPFD limits in the K_a band case.

As the EPFD changes with satellite motion, it is necessary to investigate the percentages of time during which the EPFD exceeds various values. Through estimations and simulations, it has been found that the general EPFD value is exceeded in less than 65 % of the time when using the 12H3S3P satellite constellation. According to the Radio Regulations, a HEO satellite system may not radiate into GEO systems an EPFD of -182 dBW/m^2 in more than 71.4 % of the time [34]. Thus, the preliminary analysis indicate that the K_a band solution is not in violation of the interference regulations after all.

From these preliminary interference considerations, it is concluded that the proposed system will not violate the regulations as set by ITU. Both the K_u and the K_a band case conform to the limits as discussed previously. The fact that frequency coordination with GEO based satellite systems is not needed, is a great advantage for the system solution. However, it must not be forgotten that it is still necessary to frequency coordinate with any other non-geostationary satellite systems with an overlapping frequency plan.

8.6 Selecting frequency band

The results presented in this chapter demonstrate that the two frequency band alternatives are both able to support the desired performance. Thus, it has been confirmed that they both are viable candidates for use in a HEO based satellite communications system serving the Arctic and high latitude regions. However, there are some differences in terms of advantages and disadvantages. These differences must be considered in a trade-off study before selecting the appropriate frequency band.

Preliminary GEO interference estimates indicate that neither the K_u or the K_a band solution trigger a need for frequency coordination with GEO systems. In the K_u band, case the interference level created is far below the limits set by ITU. The interference level induced in a GEO satellite system by the K_a band

solution do actually breach the EPFD limits on the return uplink for some of the services. However, as this only occurs during short periods of time around satellite handover, it is accepted. Interference and potential frequency coordination issues with GEO satellite systems can, therefore, not be used to differentiate the two frequency band alternatives.

The earth station types and service levels proposed result in similar antenna diameters for the two frequency alternatives. There are slight differences only for the high performance services. The earth station antenna diameters proposed for broadband service level D and backhaul services are slightly larger in the K_a band. This difference is, however, assumed to be too small to have a significant impact on frequency selection. One antenna dimension issue that do have an impact, is the regulations regarding minimum earth station antenna diameter for the K_u band GEO systems. It is uncertain if these regulations apply to a HEO system, but they will apply to users roaming between HEO and GEO. Such restrictions do currently not exist for the K_a band. That speaks in favor of using the K_a band for the provision of communications services in a HEO satellite system for the Arctic.

One of the disadvantages with the K_a band solution, when compared to the K_u band solution, is the high satellite power required. The need for about twice as much satellite transmitting power will lead to higher satellite cost. More powerful transponders have a larger mass and consume more power. Thus, larger and more powerful satellites are necessary. Increased satellite mass also has a negative impact on launch cost. Quantification of this cost difference require further studies, but this is given some consideration in Chapter 9.

The conclusion at this point is that differences between the frequency band alternatives are still deemed too small to make a credible decision on the selection of a frequency band. These differences and their effect on system cost and viability are also associated with a high degree of uncertainty. While the K_u band alternative can potentially be launched with a lower space segment cost, the limitations on earth station antenna size have a negative effect on the potential customer base of the satellite system. A credible decision on a frequency band for an HEO satellite communications system must trade-off these two considerations. The first step is to do a preliminary analysis of the power, mass and cost differences between the two alternatives. This issue is addressed in the next chapter.

Chapter 9

Satellite dimensioning and cost

Satellite dimensions such as mass, power and number of transponders have a profound impact on system cost. Based on capacity requirements and expected performance, the satellites in a communications system can be sized. Construction costs for satellites typically depend on system complexity, number of transponders and the power required for operations of the satellites. Launch costs are heavily influenced by satellite mass. Launchers have different capabilities, and satellite mass constrain the number of potential launchers. Insurance costs are in turn dependent on choice of launcher.

In this chapter capacity requirements are considered, and the payload is sized. Communications payloads with 18 active transponders are proposed for the three satellites. Power requirements are estimated based on the payload size. Payload size is also used for estimation of satellite mass. Launchers capable of lifting the estimated satellite mass into the desired orbit are then discussed. The Falcon 9 launcher is selected due to the low cost. The chapter concludes by presenting a rough order of magnitude cost estimate for the space segment. Estimates indicate that the K_u band alternative will cost around 544.5 million US\$ while the K_a band alternative will cost around 577.5 million US\$.

9.1 Capacity considerations

The communications capacity requirements for the Arctic were considered in section 2.1. Based on assumptions and expectations for activities in the Arctic and their communications demands, capacity requirements were esti-

mated. The findings were summarized in Table 2.1. It is logical to dimension the satellite system with a capacity according to those figures. Capacity considerations are limited to backhaul, broadband and broadcasting services as they have been defined in the previous chapters. The distress and safety service is in terms of capacity requirements assumed to be part of the broadband service. Thus, it is not included in the capacity considerations.

When dimensioning the satellites to provide adequate capacity, the total capacity requirement given for the three relevant services in Table 2.1 will be used. Furthermore, these figures are assumed to be the forward link requirements. Additional assumptions for the return link requirements of the backhaul and broadband services are, therefore, needed. As the backhaul service is symmetrical, it has the same capacity requirements on the return link as on the forward link. For the broadband service, it is more complicated as it depends on the user type composition and their chosen service level.

It is assumed that a backhaul capacity of 200 Mbit/s is required in both transmission directions. Given the performance proposed for the backhaul services in section 2.4, this allows provision of services to between ten service level A stations and twenty level B station. A single forward link carrier can accommodate up to 6 backhaul service level A earth stations. Thus, up to two satellite transponders are needed for support of the backhaul service forward link capacity requirements. As the backhaul service is synchronous, two satellite transponders will also be needed for the return link.

The number of transponders needed to provide a certain broadband capacity depends on the distribution of traffic and users between the various service levels. If a majority of the users has large antennas, the higher spectral efficiency they support reduce the bandwidth needed to provide a given total bit rate. A reduced total bandwidth result in a need for fewer transponders. With a high proportion of service level A and B users, the number of transponders needed is higher. Based on the broadband capacity requirements proposed in Chapter 2.1, it is assumed a total broadband bit rate of 500 Mbit/s is needed on the forward link. The hypothetical lowest number of transponders is required if all broadband users are of the service level D type. Total broadband forward link capacity of 500 Mbit/s can then be provided on a bandwidth corresponding to approximately 3.7 transponders. If, on the other hand, only service level A is used, a bandwidth corresponding to more than 6.3 transponders is needed for support of the total broadband capacity. As the user composition in reality will be somewhere between these to extreme cases, the appropriate number of transponders supporting the broadband forward link should then be some-

where between 3.7 and 6.3. In the absence of knowledge on how users will be distributed between service levels, it is assumed that 5 transponders are adequate for the provision of the required forward link broadband capacity.

The return link speed of the broadband service levels proposed in section 2.4 is 50 % of the forward link speed. Thus, a forward link capacity requirement of 500 Mbit/s lead to a return link capacity requirement of 250 Mbit/s. Of course, the number of transponders needed to support such a capacity depends on the composition of user types also for the return link. With only service level D users, a bandwidth equivalent to about 2.8 transponders is needed for support of the required broadband return link capacity. In the other end, a bandwidth equivalent to approximately 5.1 transponders would be needed if the broadband service only has level A users. Based on these figures and assuming a mixed user group, it is deemed appropriate to require 4 transponders for support of the broadband service return link.

In section 2.4, it was estimated that a broadcasting package with 30 channels, including 10 HDTV channels, would require a satellite capacity of 230 Mbit/s. Given the coding and modulation mode selected for the broadcasting service in Chapter 8, the broadcasting carrier bit rate is 66.8 Mbit/s. Thus, one 36 MHz transponder can handle about 30 % of the proposed broadcasting service content. Transmission of the full 230 Mbit/s requires a bandwidth equivalent to 3.4 transponders. Full broadcasting service across the coverage area from one satellite requires 3.4 transponders for each of the seven spot beams. The specified broadcasting service would then require between 20 and 30 transponders under these conditions. That is not seen as a viable business case.

To a large extent, broadcasting content is of a regional nature. Therefore, pan Arctic distribution is not required for all the TV channels that are part of the broadcasting service. It is assumed that, through careful regional bundling of content, an acceptable broadcasting service can be provided by the satellites with one transponder per spot beam. Under these conditions, distribution to the whole extended coverage area by one satellite require 7 transponders. The constellation selected for this system provides dual satellite coverage. Hence, it is possible to reduce the number of transponders for broadcasting services on each satellite without losing coverage. However, for redundancy in case one satellite fails, one satellite should be able to distribute broadcasting content across the coverage area. The dual satellite coverage can also be used to improve the broadcasting service in some spot beams beyond what is possible with one transponder. Thus, it is recommended to equip each of the satellites with 7 transponders for the provision of broadcasting services.

Redundancy is an important issue when dimensioning a satellite system. For this system, redundancy must be considered on two levels; the satellite level and the system level. It is normal to design a satellite payload with extra transponders. If one transponder malfunctions, the traffic can then be moved to one of the spare transponders. Because of power constraints, it is typically not possible to switch on one of the spare transponders without switching off another. Dual satellite coverage redundancy requires the satellites in this HEO system to be able to power spare transponders without switching off others. The idea is that if one of the active satellites malfunctions and are not able to handle its share of the traffic, the other satellite can take up the slack. Such a system level redundancy reduce the redundancy requirements on the satellite level. This functionality can also be used to share the traffic load between the two active satellites. With load sharing between the satellites they do not have to be dimensioned for peak traffic. Excess traffic can be moved to the satellite above North America in periods of heavy traffic in the European Arctic, and vice versa.

In total, the backhaul and broadband services requires 7 transponders for the forward link and 6 transponders for the return link. As two satellites are active at all times, the system can provide the required capacity with 4 transponders for the forward link and 3 transponders for the return link on each satellite. When adding the 7 transponders for the provision of broadcasting services, the number of transponders required on a satellite is 14. A flexible system architecture allows transponders to be used for different services according to traffic demand. Thus, if the broadcasting service has overcapacity, resources can be reallocated to backhaul or broadband services. This also works the other way around if the broadcasting capacity requirement has been underestimated. A three for two transponder redundancy would then suggest satellite payloads with 14 active transponders and 7 spare transponders. With redundancy also available on the system level, this can be reduced. Thus, it is deemed appropriate to design the satellite payloads with 18 transponders that can be active simultaneously.

9.2 Payload power consumption

A communications payload onboard a satellite consist of many components. How the payload is put together, depend on system architecture and design. The system studied here, use a transparent satellite payload. Transparent payloads typically consist of a receiver part, a high power amplification part

Table 9.1: Power consumed by one single transponder, all 18 transponders on a satellite and the payload as a whole.

Frequency	Single transponder [W]	Total transponder [W]	Payload [W]
K _u band	140	2 520	2 800
K _a band	280	5 040	5 600

and a transmitter part. The receiver part of the payload include a low noise amplifier and a local oscillator for frequency conversion. Output from the receiver is fed to an input multiplexer which ensures that the various carriers are directed to the correct transponders. After amplification in the transponders the signals enter the transmitter part, where the antenna feeder network tailor the radio signals to achieve the necessary spot beam configuration. Power is consumed throughout the payload, but the payload power requirements are dominated by the transponders performing the high power amplification of the radio signals. In these preliminary estimates, it is assumed that the power consumed by the transponders constitutes 90 % of the total payload power consumption.

The saturated transmitting power of a transponder used in the link budget calculations was in section 7.7 set to 100 W in the K_u band case and 200 W in the K_a band case. TWTA transponders for commercial satellite applications can be expected to have a Direct Current (DC) to Radio Frequency (RF) conversion efficiency around 60 % to 75 % [7]. Based on this it is assumed a transponder power efficiency of 70 % can be used as a conservative parameter in estimates of the transponder power consumption. Thus, one K_u band transponder is expected to consume about 140 W while one K_a band transponder is expected to consume 280 W. In Table 9.1 these values are listed.

In the previous section, it was found appropriate to equip the satellites with 14 transponders for nominal operations. For redundancy, both on satellite and system level, as well as to allow traffic load sharing between the active satellites, 4 additional transponders were proposed. Thus, the satellite bus must be able to power up to 18 transponders simultaneously, and the total transponder power consumption for a satellite can then reach up to 2 520 W in the K_u band case and up to 5 040 W in the K_a band case.

These transponder power consumption values can be used to estimate the total payload power consumption. Assuming 90 % of the payload power is

consumed by the transponders, a K_u band based payload will consume an estimated 2 800 W. The total payload power consumption is estimated to about 5 600 W in the K_a band case. These findings are summarized in Table 9.1.

9.3 Satellite platform power requirements

The main task of a satellite bus is to take care of the payload, and make sure it can perform the intended function. In addition to supply the payload with enough power and ensure correct attitude and orbit control, the satellite bus must also monitor the health of the payload and itself. All these responsibilities consume power. A satellite bus can be divided into subsystems which take care of different tasks. The attitude control subsystem ensures the satellite has the correct attitude, normally through the use of reaction and momentum wheels. Orbit maneuvers are performed by the propulsion subsystem. It can also be used to dump momentum from the momentum wheels when they come close to their operating limits. The power subsystem generates power using solar arrays and distributes it to the various subsystems and payload. A satellite also needs a telemetry and control subsystem which act as the brain in the satellite. This subsystem monitor and collect housekeeping data from all the other subsystems and the payload. The housekeeping data is then sent down to a control and operations centre on the ground. Simple control tasks may be done autonomously onboard the satellite, but mostly satellite operators on the ground send commands to be executed by the satellite control subsystem.

How much power the various subsystems consume depend on design, technology and size of the satellite. It is not unlikely in a communications satellite that each of the subsystems can consume up to 5 % of the total satellite operating power. There may also be additional power consumption not considered here, but they are assumed to be negligible. It can be assumed that the payload of a medium to large communications satellite will consume up to 80 % of the total satellite operating power [17]. Based on the payload power estimated in the previous section a satellite power requirement can be found. The K_u band alternative will need a satellite power of about 3 500 W while the figure is as high as 7 000 W for the K_a band alternative. Although the power requirements differ between the two frequency band options, they are both achievable with communications satellite platforms currently commercially available.

The power necessary for operations of the satellites must be generated onboard

the satellites by solar panels. Solar cells on the panels convert energy radiated from the sun into electricity using semiconductor technology. Historically, silicon based solar cells have been used on commercial satellites. The efficiency of silicon cells has improved from less than 10 % in the 1960s towards 18 % to 20 % at present. Solar cell panels using Gallium Arsenide (GaAs) technology have always been known to have a higher energy conversion efficiency than silicon based cells. However, GaAs cells were substantially more difficult to fabricate, and not cost competitive compared to silicon solar cells. Thus, deployment of solar panels based on GaAs technology in commercial satellites was very limited for a long time. This has now changed with the development of new production techniques where GaAs is grown and doped on germanium substrate [7].

Commercial communications satellites launched today, typically have solar panels with triple junction GaAs technology. Currently, a beginning of life efficiency of around 30 % can be expected from GaAs based solar panels. In addition to the high efficiency, GaAs cells are also more resistant to the effects of radiation. Whereas the performance of silicon cell panels degrades by more than 30 % during a typical GEO satellite lifetime, GaAs cells have performance degradation of only 10 % to 15 %. In the harsh radiation environment experienced by a HEO satellite, this is important to ensure an acceptable satellite lifetime.

The amount of solar cell area, S , needed to produce a certain power, P , can be estimated using the following equation:

$$S = \frac{P}{\psi(1 - \rho)\eta_{sp}} \quad (9.1)$$

where ψ is the solar flux captured by the solar cell, e_s is the solar cell energy conversion efficiency and ρ is losses due to cover and cabling. At the distance the earth is from the sun, the nominal solar flux is about $1\,370\text{ W/m}^2$. The losses due to cover and cabling are typically in the order of 10 % to 15 %. Solar panels consist of many solar cells which are stacked as close together as possible. The filling efficiency of a solar panel is typically from 85 % to 95 % [7].

At the beginning of life, a modern GaAs solar panel is assumed to have energy conversion efficiency of 30 %. It is furthermore assumed that cover and cabling losses can be limited to 10 % and that a filling efficiency of 95 % can be achieved. With these parameters, a solar panel area of about 10.5 m^2 would be necessary for generation of the $3\,500\text{ W}$ required for the K_a band alternative. The $7\,000\text{ W}$ necessary to power the K_a band alternative requires a solar panel

area of about 21 m^2 . In the calculations, it is also assumed that the solar cell panel surface is perpendicular to the direction towards the sun.

However, the area of the solar panels onboard satellites must be dimensioned according to end of life conditions, not beginning of life. In the radiation environment experienced by GEO satellites, GaAs cells have a performance degraded with around 15% at the end of a 12 to 15 year satellite lifetime. The satellites in the 12H3S3P constellation will pass through the Van Allen radiation belts several times each day. Hence, they will experience a radiation environment harsher than in GEO. This makes the end of life degradation of solar panel performance more severe for HEO satellites. How much harsher the environment is, and its exact effect, is somewhat uncertain, but an end of life degradation of solar panel performance in the vicinity of 30% is not unlikely. If a 30% end of life performance degradation is assumed, the solar panel area must be increased to 15 m^2 and 30 m^2 for the two frequency band alternatives.

The required solar panel areas are too large for a spin stabilized satellite. Thus, three-axis stabilized satellites with unfurlable solar panel arrays are required for the proposed satellite system. Using such satellites, the 30 m^2 solar panel area needed in the K_a band case can also be accommodated on existing satellite platform designs. With a solar panel height of 2.5 m, two unfurling solar panel wings attached on opposite sides of the satellite would need to be 3 m long with the K_u band alternative and 6 m long with the K_a band alternative.

Attitude control increases in importance if a three-axis stabilized communications satellite with solar panel wings is deployed in a HEO orbit. The antennas providing the communications coverage will typically be placed on the nadir panel. The satellite antenna solution discussed in section 7.6 has steerable spot beams, but it is still necessary to keep the nadir panel pointed towards the earth. This can either be towards the sub satellite point, or a fixed point such as the projected centre of the coverage area. This is necessary to limit antenna gain reduction, and it reduces the complexity of the spot beam steering and control system. The attitude constraint imposed by the antenna system on the satellite lock roll and pitch. Correct pointing of the solar panels towards the sun impose another constraint on the attitude control system. While roll and pitch must be constantly adjusted to keep the antenna system pointed correctly, yaw must be adjusted in order to keep the solar panel axis perpendicular to the direction towards the sun. The solar panel arrays must then be rotated independently of the satellite body to keep the surface pointed towards the sun. Now, it should be noted that the yaw rotation must be countered

by the antenna system for the spot beams to be kept stable over an area. However, this is not expected to add significant complexity to the antenna steering and control system.

9.4 Satellite mass

This study has not looked at the satellite design at a hardware and component level. It is, therefore, not possible to provide any accurate estimates on satellite mass at this stage. However, since system costs typically are correlated with satellite mass, a preliminary mass estimate as early as possible in the system design process is valuable. An early rough estimate of satellite mass is useful for narrowing down the field of potential launchers. It can also provide an indication on appropriate satellite platforms for such a communications system.

The number of transponders necessary to meet capacity requirements dimensions the satellites. Thus, it is logical to base the satellite mass estimates on the amount of transponders onboard the satellite. Previously in this chapter it was proposed to design the three satellites in the constellation with communications payloads having 18 active transponders. This number has been used in two different approaches for estimating the satellite mass. The first approach uses a bottom-up procedure based on historical data of mass distribution between payload and subsystems onboard communications satellites. Satellite mass estimating approach number two is based on a simple survey of 94 K_u and K_a band communications satellites launched into GEO between 2000 and 2012. All the satellites considered in the survey are three-axis stabilized

In Table 9.2, the results of the bottom up procedure for estimating the satellite mass is presented. Transponder mass forms the foundation in this estimation procedure. For the K_u band case, a transponder mass of 9 kg is assumed. The higher transmit power required in the K_a band alternative is expected to increase the transponder mass compared to K_u band. Thus, a somewhat higher transponder mass of 12 kg is assumed for the K_a band case.

A communications payload onboard a satellite consists of more than transponders. There are antennas, feeder network, low noise amplifiers, cables, waveguides and so forth. Some structure and casing is also necessary to keep all components in place and attached to the satellite. It is assumed that these elements together add mass to the payload in the same order of magnitude as the transponders. Therefore, in the satellite mass estimates provided in Table 9.2, a transponder mass to payload mass percentage of 50 % have been used.

Table 9.2: Results and summary of key values for the bottom-up satellite mass estimation procedure.

Parameter	K _u band	K _a band	Unit
Number of transponders	18	18	
Mass per transponder	9	12	kg
Total transponder mass	162	216	kg
Transponder mass to payload mass percentage	50	50	%
Payload mass	324	432	kg
Payload mass to satellite dry mass percentage	35	30	%
Satellite dry mass	926	1 440	kg
Dry mass to launch mass percentage	65	65	%
Satellite launch mass (separated mass)	1 424	2 215	kg

The result is an estimated payload mass of 324 kg in the K_u band case, and 432 kg in the K_a band case.

Historical data on the distribution of mass between subsystems on communications satellites indicate that the payload normally constitute between 25 % and 35 % of the satellite dry mass. The subsystem that contribute the most to satellite dry mass is the power subsystem, typically 30 % to 40 % [17]. Much of the power subsystem mass comes from the use of large solar panels, but large batteries with the capacity to power the satellite during a solar eclipse is also a large contributor. The HEO satellites in the constellation proposed here will never experience a solar eclipse while in the active part of the orbit. Hence, battery requirements can be significantly reduced. Less battery capacity reduces the mass added by the power subsystem, which in turn increase the payload mass to satellite dry mass percentage. For the K_u band alternative, it has been deemed appropriate to expect that 35 % of the satellite dry mass can be attributed to the payload. The high power requirement in the K_a band case means larger solar panel arrays. Larger solar panel arrays will of course tilt the mass distribution back towards the power subsystem. A payload mass to satellite dry mass percentage of 30 % is, therefore, assumed for the K_a band alternative. Based on these assumptions the satellite dry mass has been estimated to 926 kg and 1 440 kg for the two frequency band alternatives.

The satellite launch mass also includes propellant for orbit maneuvers during satellite operations and the initial orbit insertion. In GEO satellites designed for 12 to 15 years of maneuver lifetime, propellant constitute more than 50 % of the satellite launch mass. This includes propellant for stationkeeping, and a substantial amount of propellant for moving the satellite from Geostationary

Transfer Orbit (GTO) to the desired position in GEO. Typically, when a GEO satellite reaches its orbit, the mass is reduced to about 60 % to 65 % of the initial launch mass. HEO satellites are expected to need more propellant for stationkeeping than GEO satellites, but a launch injecting the satellite directly into the correct orbit should be possible. Thus, the propellant requirement of HEO satellites is limited to small initial orbit adjustments and stationkeeping.

It is normal for GEO satellites designed with a lifetime of 12 to 15 years, to be launched with propellant mass for stationkeeping proportionate to 40 % of the satellite dry mass. Assuming a direct injection launch, this corresponds to a dry mass to launch mass percentage of about 70 %. In Chapter 5, it was assessed that satellites in a 12H3S3P constellation would have about 17 % shorter maneuver lifetime compared to GEO. As a countermeasure to the higher stationkeeping costs in HEO, the propellant mass should be increased with 20 % to 25 %. A satellite dry mass to launch mass percentage of 65 % is, therefore, deemed to be appropriate. The resulting estimates for satellite launch mass are presented in Table 9.2. A system solution utilizing the K_u band alternative will need satellites with an estimated launch mass of 1 424 kg. For the K_a band alternative the estimated launch mass is 2 215 kg. It is important to note that this is only preliminary and rough order of magnitude estimates, and should be treated accordingly.

The other estimation method for satellite launch mass, is based on a simple survey of 94 K_u and K_a band communications satellites launched into GEO between 2000 and 2012. This mass estimation approach is very rough, but it can be used to verify the validity of the assumptions made by the first mass estimation method. Information freely available on the internet have been used to look at the relationship between satellite launch mass and the number of transponders fitted on various GEO satellites. The results of this survey are shown as the blue dots in Figure 9.1. The dots indicate the number of transponders on a satellite on the x-axis, and the satellite launch mass, including propellant for GTO to GEO transfer, on the y-axis.

It should be noted that there are inaccuracies connected to the data found in this survey. For some satellites the number of transponders refer to the total number onboard the satellite. In other cases the number indicate active transponders. Bandwidth and power of transponders also differ significantly from satellite to satellite. However, as the survey encompass as much as 94 GEO satellites, it is expected be a good indicator and provide an understanding on how transponder capacity correspond to satellite launch mass.

A polynomial curve fitting method has been used to find the coefficients of

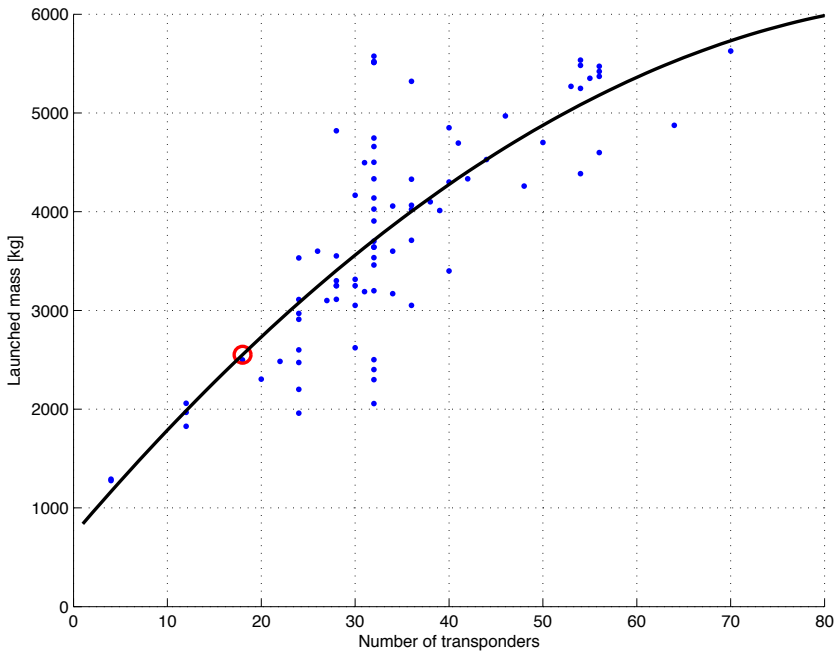

Figure 9.1: Results from the satellite launch mass estimation method based on a simple survey of 94 K_u and K_a band three-axis stabilized communications satellites launched into GEO between 2000 and 2012. Blue dots indicate the relationship between number of transponders and satellite launch mass for the different satellites. The black line indicate an estimate for satellite launch mass as a function of the number of transponders based on a least square curve fitting of the survey data. The red circle denote the 18 transponders proposed for the satellites in the system studied here. Launch mass values include propellant for GTO to GEO transfer.

a second degree polynomial that fits the data in the least square sense. This polynomial is assumed to indicate an average satellite launch mass as a function of the number of transponders on a satellite. The result is shown as the black curved line in Figure 9.1. When 18 transponders are inputted into the polynomial, estimated launch mass for the satellites proposed for this Arctic system can be found. This procedure estimate a satellite launch mass of around 2550 kg. The red circle in Figure 9.1 denotes this.

The launch mass estimate derived using curve fitting on data from the simple survey is not directly comparable with the first launch mass estimation approach. This second estimate includes, in addition to satellite dry mass and mass of propellant for stationkeeping, the mass of propellant for orbit change from GTO to GEO. As launch with direct injection into the desired orbit is

assumed possible for this HEO system, that extra propellant is not needed. For results from the two estimation approaches to be comparable, the extra propellant mass must be removed from the result of the second estimation method. A direct injection launch typically reduce GEO satellite launch mass with 35 % to 40 %. With a 35 % launch mass reduction to account for a direct injection launch, the launch mass estimate would about 1 660 kg.

This satellite mass estimate is in between the values found for the two frequency band alternatives using the first approach for estimation of mass. This is considered to be a verification and validation of the assumptions made as part of the bottom-up estimation method. Uncertainties in the estimates are still large, and further refinement of the estimates is necessary. As design choices are made and the satellite design becomes firmer, the satellite mass estimates must be revisited to improve the model. However, the preliminary results given in Table 9.2 are considered applicable at this stage. When addressing launcher options and space segment cost in the following sections, satellite dry mass of 925 kg and satellite launch mass of 1 425 kg are assumed for the K_u band solution. In the K_a band case, satellite dry mass of 1 440 kg and satellite launch mass of 2 215 kg are assumed.

9.5 Launcher options

Satellite launch mass estimates presented in the previous section indicate that the satellites in the proposed system can be fairly small, at least in comparison to most GEO communications satellites launched in the last decade. The limited communications capacity requirements in the Arctic and the possibility for a launch injecting the HEO satellites directly into their orbit are the main reasons for the low satellite mass. In addition to the satellites being small, the HEO orbits used in the proposed 12H3S3P constellation are easier to reach than GEO. The launch cost evaluation presented in Chapter 5 indicated that launch into the desired HEO orbit requires only 62 % of the ΔV necessary to reach GEO. In the 12H3S3P constellation, the three satellites must be positioned in individual orbital planes. Such a configuration is most effectively achieved when all three satellites are launched individually.

The limited launch capabilities required to put the satellites in a 12H3S3P constellation into orbit allow for several launcher options. All current commercially available launchers used for launching of GEO satellites have the necessary capabilities. The 12 h HEO orbit stipulated for the 12H3S2P con-

stellation has similar characteristics as a GTO. Apogee and perigee altitude for the relevant HEO are slightly higher than a normal GTO. Thus, the GTO mass capability of a launcher is somewhat higher than its 12 h HEO mass capability. However, ΔV estimations performed as part of the launch cost evaluation presented in Chapter 5 indicate that the mass capability difference between GTO and the proposed HEO is less than 2%. The ability to put the required satellite mass into GTO is therefore used as a benchmark when considering potential launcher alternatives for the HEO system studied here.

A number of launcher alternatives are listed in Table 9.3 along with launch site, performance and rough cost figures. Only launchers capable of lifting necessary satellite mass into the desired orbit are included. The performance of the various launchers, in terms of launchable mass to LEO and GTO, are based in information from user guides issued by the different launch providers. Rough cost figures are derived from publicly available information such as press releases. Most launch providers do not announce their launch cost, and prefer their costumers to keep it confidential. The only launch provider publicly announcing their price list is Space Exploration Technologies Corporation (SpaceX), which is the provider of the Falcon launchers.

Of the alternatives considered here, the Delta 2 launcher has the lowest performance to GTO with only 2 120 kg. This is adequate, and allow a substantial margin, for launch of the K_u band alternative with estimated satellite launch mass of only 1 425 kg. For the K_a band alternative, with estimated satellite launch mass of 2 215 kg, the Delta 2 launcher is not powerful enough. In theory, Delta 2 could be used to launch the satellites in a K_u band alternative, but Delta 2 launches have not been offered to the commercial communications satellite for at least a decade. The last such Delta 2 launch was with five Iridium satellites in 2002. It should also be noted that other more powerful launchers are available at a lower cost.

All the other launcher alternatives listed in Table 9.3 are able to launch both satellite configuration alternatives into the proposed 12 h HEO. Long March 3A is the smallest launcher after Delta 2. According to performance specifications issued by the launch provider it can put up to 2 600 kg into GTO. This version of the Long March 3 launcher has not launched commercial communications satellites, only Chinese governmental navigation and communications satellites. Therefore, it is assumed to be unavailable for launching of the communications system addressed here.

A Soyuz launch from Kourou is the smallest truly commercially available alternative with the performance necessary to put the satellites in the proposed

Table 9.3: List of launcher alternatives capable of lifting the necessary mass into the desired orbit. Launch performance is based on user guides issued by the various launch providers. Cost figures are derived from publicly available information, and are only rough estimations. Launch sites are abbreviated as CC and VB for Cape Canaveral and Vandenberg in USA, X for Xichang in China, B for Baikonur in Kazakhstan, K for Kourou in French Guyana and POP for Pacific Ocean sea platform.

Launcher	Launch site	Mass to LEO [kg]	Mass to GTO [kg]	Cost [M US\$]
Atlas 5	CC/VB	9 800	4 750	150
Delta 2	CC/VB	5 430	2 120	80
Delta 4	CC/VB	9 150	4 300	150
Falcon 9	CC/VB	13 150	4 850	54
Falcon Heavy	CC/VB	53 000	12 000	128
Long March 3A	X		2 600	
Long March 3B	X		5 500	68
Long March 3C	X		3 800	
Proton	B	23 000	6 150	110
Soyuz	K	4 850	3 250	80
Zenit-3SL	POP		6 000	
Zenit-3SLB	B		3 600	

system into their orbit. The 3 250 kg it can launch into GTO is about twice the requirement for the K_u band alternative and leaves a substantial margin with the K_a band alternative. Currently, the cost of a Soyuz launch from Kourou is assumed to be in the area of 80 million US\$.

Even though it has a higher performance, a Falcon 9 launch is expected to have a substantially lower cost compared to a Soyuz launch. The list price of a Falcon 9 launch is currently 54 million US\$. That price is based on an upfront cash payment. Thus, the actual cost is likely closer to 60 million US\$. However, a launch order for three identical satellites can be expected to generate a discount. With the current list price, a cost per launch of 55 million US\$ should be realistic for three HEO satellites launched into 12 h orbits.

In the current launch market the Falcon 9 launcher seems to be the most cost efficient alternative, and it is proposed for the system studied here. The three Falcon 9 launches required for a complete and fully operational constellation are expected to cost around 165 million US\$. A Falcon 9 can lift up to 4 850 kg into GTO. This is substantially more than required for either of the two frequency band alternatives. The additional mass capacity can be used for addi-

tional propellant on the satellites, which will increase their maneuver lifetime. It is also possible to increase the size of the solar panel arrays. Larger solar panel arrays for power generation will allow a higher degradation level before services are affected. This improves the operational lifetime for the satellites.

The apparent mismatch between current launcher capabilities and requirements of the proposed system prompts an important question. A HEO based satellite system providing communications services to the Arctic can support the current, and near term future, traffic demand with fairly small satellites. With such small satellites, it would be attractive to take advantage of a dual launch. This is not an option for a system using the 12H3S3P constellation, but it is a good match with some of the other constellation alternatives evaluated in Chapter 5 employing two satellites in a single orbital plane. 12H2S1P and 16H2S1P are the most obvious examples. Note that this constellation only have one active satellite at a time. Load sharing are then not possible, and redundancy would be limited to the satellite level. The satellite in these constellation alternatives would, therefore, have to be larger and more powerful than in a 12H3S3P constellation. Dual launch of such satellites would likely require the larger Falcon Heavy or Proton launcher. Further studies are necessary for adequate evaluation of the various cost effects of the constellation alternatives.

9.6 Space segment cost estimate

From the considerations on satellite dimensions, mass, power and launch options, rough order of magnitude cost estimates for the space segment can be derived for the two frequency alternatives. When the definition of the space segment is limited to the satellites, the cost estimate will have three components. Those components are satellite cost, launch cost and insurance in case of launch or satellite failure. Often a satellite ground control centre and gateway stations are considered to be part of the space segment. It is assumed that existing infrastructure and organizations to a large extent can be used for the ground components of the space segment. This is expected to limit ground control investments to a level where it would be more appropriate to consider them as operational costs. Thus, investment costs related to satellite ground control centre and gateway stations are omitted from the space segment cost estimates presented here.

Satellite construction costs are the largest component of space segment cost.

The cost of a commercial communications satellite depends on size, capacity and complexity. In the system studied here, it is proposed to use a conventional transparent payload architecture in either the K_u or the K_a band. Such solutions have been deployed and used with the K_u band for many years already. Therefore, it represents a mature technology with low complexity and the need for new development is limited. The K_a band has not seen the same adoption for commercial satellite communications applications, but its use has gained traction in recent years. However, many of the K_a band communications satellites launched are more complex with smaller spot beams and different architecture than that proposed for this system. Hence, technology for transparent K_a band payloads are less mature than for the K_u band, but from a cost perspective the difference is not expected to be large.

Manufacturers of satellites do not operate with publicly available price lists for their satellite platforms. Thus, satellite cost must be derived from public information, such as press releases and financial disclosures. Currently, the construction cost of a commercial GEO communications satellite with 20 to 30 transponders can be assumed to lie between 110 and 130 million US\$. It is not expected that adaption of such a satellite platform to a HEO environment will have a significant effect on satellite costs. The satellites proposed for the system studied here are fairly small and have been dimensioned with only 18 transponders. A purchase order for three identical satellites will normally reduce the satellite construction costs. Satellite cost in the lower half of the likely cost range should, therefore, be realistic. Based on these considerations it is assumed that the satellite unit price in the K_u band scenario is around 110 million US\$. The somewhat larger, heavier and more powerful satellites needed to support the K_a band alternative will cost slightly more. Bearing in mind that a K_a band solution also entails less mature technology, a higher satellite unit price must be expected. For the K_a band alternative, a cost of 120 million US\$ is assumed.

The second largest space segment cost component is the launch. Alternatives and options for launch of the satellites were discussed and considered in the previous section. It was concluded that the Falcon 9 launcher would provide orbit insertion of the HEO satellites at the lowest cost. Also, the launch contract cost will be discounted when one order cover multiple launches. A cost per launch of about 55 million US\$ was assumed to be realistic for launching of three 12 h HEO satellites forming the 12H3S3P constellation.

Insurance is the third and last cost component considered here. The insurance industry is today willing to provide insurance against almost anything, given an

adequate premium is paid. However, even though it is possible to insure something, it is not necessarily the most cost efficient thing to do. Whether it is appropriate to take out insurance depends on the risk of an incident to occur, the premium required, the consequence of an incident and the financial situation of the policyholder. Communications satellites are typically insured against launch failure and sometimes in-orbit performance failure. Insurance against in-orbit performance failure or loss cover revenue losses due to satellite malfunctions occurring after a satellite has reached its orbit and begun operations. Banks financing satellite communications systems may demand such an insurance if the satellite operator does not have redundant satellite capacity in orbit.

A launch failure insurance cover, as the name indicates, launch failures, and is typically valid from lift-off to in-orbit checkout is complete. This is the most expensive insurance, and the premium vary between launchers according to their success rate. In the early eighties, insurance premiums was normally between 5 % and 10 % of the total satellite and launch cost. After several launch failures and satellite malfunctions in the late eighties, insurance premiums rose as high as 25 % to 30 %. As the success rate of launchers has increased again, the premiums have come down over the last two decades. Currently, launch failure insurance with the highly reliable Ariane 5 and Proton launchers can cost as little as 10 % to 13 %. Satellite operators have different policies on launch failure insurance. Satellites financed through bank loans are typically required to have such insurance. Other satellite operators choose not to insure against launch failure, and instead invests in in-orbit backup satellites.

The HEO system studied here will have redundancy on a system level. Thus, should one satellite malfunction in orbit the available system capacity will be reduced, but continuous coverage will not be lost. Insurance coverage against in-orbit performance failure is deemed unnecessary for the proposed satellite system. Launch failure coverage is, on the other hand, necessary. However, the system level redundancy, which allow the system to provide continuous coverage and substantial capacity with only two functioning satellites, should be able to reduce the cost of launch failure insurance. It is assumed to be appropriate to take out launch failure insurance only on two of the three satellite launches. This is deemed to reduce the cost of the space segment substantially without introducing unacceptable risk.

As mentioned previously, the insurance premium vary between launchers according to their expected reliability, which is based on historical success rate. The Falcon 9 launcher is a relatively new launcher. To date, only three Falcon 9 launches have been executed since June 2010. Although all three launches

Table 9.4: Overview of the cost estimate for the space segment. An insurance premium of 15 % of the launch and satellite cost is assumed. Because of the redundancy in the system it is proposed to only insure two of the three launches. All values are in million US\$.

	K _u band	K _a band
Launch cost per satellite	55.0	55.0
Total launch cost	165.0	165.0
Construction cost per satellite	110.0	120.0
Total satellite construction cost	330.0	360.0
Insurance cost per satellite	24.8	26.3
Total insurance cost	49.5	52.5
Estimated space segment cost	544.5	577.5

have been successful, the satellite insurance community is not convinced on the reliability of Falcon 9. Additional launches are needed before insurers are sufficiently comfortable with Falcon 9 to bring the insurance rates down towards those available for Ariane 5 and Proton. In the cost estimates performed here, an insurance premium equal to around 15 % of launch and satellite cost is assumed likely for a Falcon 9 launch. That corresponds to 24.8 million US\$ for the K_u band alternative and 26.3 million US\$ in the K_a band case.

Table 9.4 presents an overview of the space segment cost estimate. Total cost for the space segment of the proposed HEO based satellite system is estimated to 544.5 million US\$ in the K_u band case and 577.5 million US\$ for the K_a band alternative. These are only preliminary and rough order of magnitude cost estimates. They have significant error margins and must be revised as the system design evolves. The difference in cost between the two frequency alternatives is small, and within expected error margins for the cost estimates. It is, therefore, not pertinent to select frequency band alternative based solely on these space segment cost estimates. Other elements may influence the business case, and justify the slightly higher space segment cost of the K_a band alternative. Examples of such elements are the potential for smaller earth station antennas and roaming alternatives.

Although these are only rough order of magnitude cost estimates which are prone to error, they can still be useful. Based on the estimates it is possible to start looking at potential finance solutions for a system providing communications services to the Arctic and high latitude regions. Indications on end user cost for the various services necessary for sustainable operations of such a satellite system can also be derived from these cost estimates.

Chapter 10

Conclusions and system summary

This thesis has presented a study of system solutions and alternatives for a satellite system providing communications services to the Arctic and high latitude regions. A feasible system solution has been outlined that satisfy expected communications requirements in terms of performance and capacity. This solution provides continuous and quasi-stationary coverage from two satellites at fixed apogee locations using a constellation of three HEO satellites in 12 h orbits. A system based on this outline can be expected to provide reliable services with a high availability, at a performance level comparable to GEO systems. HEO satellites in 12 h orbits are exposed to a harsh radiation environment, which potentially reduce the lifetime of such satellites. The need for three launches to orbit the constellation is also a cost driver. In a case where the cost effects from this are more negative than expected here, a viable alternative is a constellation of two HEO satellites in 16 h orbits and one orbital plane.

10.1 Arctic communications requirements

Assumed total forward link capacity requirements for the Arctic are between 100 Mbit/s and 200 Mbit/s for backhaul services and 300 Mbit/s and 500 Mbit/s for broadband services. A broadcasting service with 20 to 30 TV channels can also be assumed appropriate. Access to broadband, backhaul and broadcasting services via satellite are currently limited to areas reachable from GEO. The

coverage requirement of the proposed system has, therefore, been defined to the area above 70° northern latitude. To increase the potential user group and allow for seasonal traffic variations an extended coverage area going down to 60° northern latitude is pertinent.

10.2 Alternative satellite orbits

A constellation of HEO satellites are best for Arctic communications coverage. High orbital eccentricity allows for quasi-stationary satellite conditions. A repeating ground track allows users access to satellites in predictable positions. This can be provided with orbital periods close to 12 h, 16 h, 18 h and 24 h, adjusted to ensure the satellites completes an integral number for orbits in an integral number of sidereal days. Orbits with an inclination of 63.4° is preferable as the net effect of the non-spherical earth induce no drift in the argument of perigee. This allows for fixed apogee locations while minimizing the propellant needed for stationkeeping. A higher inclination is possible, and it does improve the coverage, but in that case more frequent orbit maneuvers are necessary for stable apogee locations. Appropriate eccentricity vary between the four alternative orbital periods. Maximum eccentricity is bounded by minimum perigee altitude and maximum apogee altitude while minimum eccentricity is bounded by coverage requirements.

10.3 Effects of high inclination

High orbital inclination improves the coverage of a HEO satellite. However, the argument of perigee of a HEO satellite will drift if the inclination is not 63.4°. This perigee drift increases with a higher inclination, and is boosted further by high eccentricity values. Increased orbital period will, on the other hand, reduce the perigee drift. With the same inclination and eccentricity, satellites in 16 h, 18 h and 24 h orbits will experience perigee drift equal to 51.1 %, 38.8 % and 19.8 % of the perigee drift which a satellite in a 12 h orbit will experience. A stable apogee require correction of perigee drift through orbit maneuvers. The ΔV cost of correcting perigee drift also increase with inclination and eccentricity, while a longer orbital period reduces the correction cost. As a result, given the same inclination and eccentricity, keeping the apogee location fixed have a 51.1 %, 38.8 % and 19.8 % lower ΔV cost for satellites in 16 h, 18 h and 24 h orbits compared to satellites in 12 h orbits.

The difference between the orbit alternatives is actually larger since a shorter orbital period requires a higher eccentricity for a satellite to provide the necessary coverage. In absolute terms, the net effect of an inclination higher than 63.4° is reduced maneuver lifetime for the satellites. The maneuver lifetime for a given amount of propellant is decreasing with shorter orbital periods and increasing eccentricity and inclination. Only for the 24 h orbit alternative is an inclination higher than 63.4° found to be a relevant alternative for Arctic satellite communications coverage. However, the reduction in satellite maneuver lifetime is significant also for that orbit alternative.

10.4 Orbital eccentricity

Eccentricity of HEO orbits is important for satellite handover considerations. Seamless handover between satellites can be supported in two ways. Either the earth stations must be equipped with two antennas, or both the two satellites must at some point be inside the antenna beam of an earth station. A HEO satellite ground track forms closed loops around apogee when the eccentricity is within a certain boundary. This ground track intersection point can be used for support of seamless handover between satellites for earth stations with only one antenna. Size of the ground track loop and the time between consecutive passes over a ground track intersection point can be controlled through adjustment of the eccentricity. There exist eccentricity values for HEO constellation with 12 h and 16 h orbits which support both seamless handover and continuous coverage. This is also possible for constellations of three satellites in 24 h orbits inclined 63.4° and constellations of two satellites in 24 h orbits inclined 90° . For constellation alternatives using these orbits, the eccentricity was chosen to allow seamless handover support. Constellations of two satellites in 18 h or 24 h orbits do not support seamless handover. Thus, eccentricity was selected to minimize the longitudinal ground track movement during the active period of a satellite.

10.5 Constellation configuration and evaluation

Eleven constellation alternatives were defined which consisted of two or three critically inclined HEO satellites. Four alternatives using two HEO satellites in 24 h orbits inclined 75° and 90° were also considered. Differences between

the constellation alternatives include orbital period eccentricity and the number of orbital planes. Eight key performance properties were assessed in an evaluation of the constellations. Those were the effects of radiation exposure, launch cost, coverage, elevation angle, azimuth angle, frequency coordination, stationkeeping and service performance during the initial operational phase. Through the evaluation process, it became clear that all the constellation alternatives have both strengths and weaknesses. Constellation alternatives based on 12 h and 16 h orbits typically have an overall good communications specific performance, but their disadvantages include a harsh radiation environment. The constellation alternatives with 18 h and 24 h orbits were found to have a better radiation environment, but performance on communications specific properties were generally evaluated to be inferior. A constellation with three satellites in individually planed 12 h orbits was selected as a base case for system considerations. However, there are questions attached to this constellation configuration regarding the harsh radiation environment and relatively high expected launch cost. As an alternative, the good overall rating of a single plane constellation with two satellites in 16 h orbit might be preferable if launch cost and radiation environment have a more profound negative impact on the base case alternative than expected here.

10.6 Communications coverage and network topology

Array fed reflector antennas are specified for the antennas onboard the satellites. An amplitude controlled array feeding a reflector antenna allow for steering of the antenna beam pointing direction. Steerable antenna beams are advantageous for such a system since the HEO satellites will be in constant motion relative to the coverage area. The earth will also be rotating under the satellite as it moves from the handover point, through apogee and back to the handover point. This relative rotation between satellite and coverage area on earth is made more complex by yaw control constraints imposed by the solar panel arrays onboard the satellites. In such a setting, antenna beam steering is necessary to keep a spot beam fixed on the same area throughout the active period of a satellite.

Separate antennas onboard the satellites are specified for the feeder link and user link. A single antenna is deemed appropriate for both uplink and downlink on the feeder link. For the user link, it is proposed to implement a seven spot beam antenna solution onboard the satellites. Communications coverage of the whole extended coverage area is then possible with 4.4° spot beams. Such

a beamwidth ensures minimal overlap between spot beams when a satellite is at apogee. With a fixed beamwidth, such spot beams will cover a smaller area when they are at the handover point compared to at apogee because of the lower altitude. However, the reduction in altitude also decrease the free space loss. At the edge of a spot beam, this free space loss reduction is proportional to the antenna gain reduction. The result is a relatively stable received power flux density at the edge of the extended coverage area, even though the spot beam has a fixed beamwidth. An antenna beamwidth of 4.4° on the uplink and downlink for both frequency band alternatives lead to different antenna diameters at the various frequencies.

A system architecture based on a star network topology and conventional transparent satellite payloads was proposed. This solution is preferred instead of regenerative payloads providing mesh connectivity because of the inherent flexibility. A flexible system architecture allows satellite resources and capacity to be dynamically allocated to various services according to changing traffic demand and new requirements.

10.7 Service performance

The forward link is stipulated to operate with a single carrier per transponder. Data transmissions to users occur in short bursts, so a wide forward link carrier is shared among a number of users. DVB-S2 allows non-uniform error protection on the same carrier. Different services can therefore be provided on the same carrier even though the receiving earth stations have different capabilities. Smaller carriers using DVB-RCS2 and DVB-S2 coding and modulation modes are proposed on the return link, 1 MHz and 2 MHz shared channels for the broadband services and 3 MHz and 6 MHz dedicated channels for the backhaul service. Nominal coding and modulation modes necessary for the provision of the various services were selected after analysis of the forward and return link. Earth station parameters required for support of the relevant coding and modulation modes in clear sky conditions were estimated.

After considering the results from this analysis, earth station parameters necessary for support of the desired performance were proposed. In the K_u band alternative, earth stations with antennas ranging from 0.6 m to 1.3 m and 3 W to 5 W of transmitting power should be used for provision of broadband services. Under the current regulations only the service level alternative stipulating 1.3 m earth station antenna is compliant with GEO constraints. Earth

stations for broadband services should have 0.6 m to 1.4 m antennas and transmitting power of 4 W to 7 W in the K_a band. Backhaul services are suggested with earth station antenna diameter of 1.3 m and 1.6 m and 11 W and 15 W of transmitting power in the K_u band case, and 1.4 m and 1.8 m and 12 W and 15 W for the K_a band alternative. A distress and safety terminal is defined with an antenna diameter of 35 cm for both frequency band alternatives. Only the transmitting power is slightly different in the two cases, 7 W for the K_u band and 9 W for the K_a band. The broadcasting service is adapted to fit well with the performance of the low end broadband service terminals. Based on the link analysis it was also concluded that such a system would not create unacceptable interference to satellite systems in GEO.

10.8 Cost estimates

From the findings in this study, it was concluded that transparent satellite payloads with 18 active transponders are appropriate for a HEO satellite system providing broadband, broadcasting and backhaul services, as well as a distress and safety service, to the Arctic and high latitude regions. Support of the described services requires a satellite power estimated to be 3 500 W for the K_u band alternative and 7 000 W in the K_a band case. Satellite launch mass has also been estimated. A satellite maneuver lifetime of 12 to 15 years is expected with a total satellite launch mass of about 1 425 kg in the K_u band case and 2 215 kg in the K_a band case. In the current launch market, the Falcon 9 would provide the most cost effective solution for orbit insertion of the satellites. Given expected launch, satellite and insurance costs, rough order of magnitude cost for the space segment have been estimated to 544.5 US\$ and 577.5 US\$ for the K_u and K_a band alternatives. The cost difference between the two alternatives is within the error margin of the estimates. A decision on which frequency band alternative to implement can, therefore, not be made solely based on these cost estimates. The potential for smaller earth station antennas and other business case related advantages may make the K_a band alternative worth the slightly higher cost.

10.9 Overall system parameters

Key information about the HEO constellation proposed for communications coverage of the Arctic and high latitude regions are summarized in Table 10.1.

Table 10.1: Summary of key orbital parameters and information for the 12H3S3P constellation proposed for Arctic communications coverage.

Parameter	Value	Unit
Orbital period	11.962	h
Number of satellites	3	
Orbital planes	3	
Angle between orbital planes	120	°
Inclination	63.435	°
Eccentricity	0.7125	
Apogee altitude	39 109	km
Perigee altitude	1 258	km

The information includes important orbital parameters, number of satellites, number of orbital planes and the angular spacing between them. Table 10.2, on the next page, lists system parameters and performance. The system summary includes parameters such as satellite and gateway performance, earth station dimensions and service performance, as well as power consumption, mass and cost estimates. It should be noted that based on the performance indicated in Table 10.2, the proposed HEO satellite communications system can provide services to the Arctic with a performance level similar to what GEO satellite systems provide to other parts of the world by.

Table 10.2: System summary showing key parameters such as satellite and gateway performance, earth station dimensions and service performance, as well as power consumption, mass and cost estimates.

		K _u band	K _a band	Unit
Satellite	Forward uplink antenna gain	43.0	44.0	dB
	Forward downlink EIRP per carrier	50.6	53.6	dBW
	Return uplink antenna gain	32.1	32.1	dB
	Return downlink EIRP per MHz	39.8	42.7	dBW
Gateway	EIRP per carrier	75.3	76.1	dBW
	Downlink gain	56.3	66.8	dB
Earth station	<i>Antenna diameter</i>			
	Broadband service level A/B	0.6	0.6	m
	Broadband service level C	0.9	0.9	m
	Broadband service level D	1.3	1.4	m
	Backhaul service level A	1.6	1.8	m
	Backhaul service level B	1.3	1.4	m
	<i>Transmit power</i>			
	Broadband service level A	3.0	4.0	W
	Broadband service level B/C/D	5.0	7.0	W
	Backhaul service level B	11.0	12.0	W
Service performance	<i>Maximum downlink bit rate</i>			
	Broadband service level A/B	79.1	79.1	Mbit/s
	Broadband service level C	111.1	111.1	Mbit/s
	Broadband service level D	133.6	133.6	Mbit/s
	Backhaul service level A/B	133.6	133.6	Mbit/s
	<i>Maximum uplink bit rate</i>			
	Broadband service level A	1.4	1.4	Mbit/s
	Broadband service level B	1.7	1.7	Mbit/s
	Broadband service level C	2.5	2.5	Mbit/s
	Broadband service level D	4.9	4.9	Mbit/s
Power, mass & cost	Payload power consumption	2.8	5.6	kW
	Satellite power consumption	3.5	7.0	kW
	Payload mass	324.0	432.0	kg
	Satellite dry mass	925.0	1 440.0	kg
	Satellite launch mass	1 425.0	2 215.0	kg
	Estimated space segment cost	544.5	577.5	MUS\$

Acronyms

ACM	Adaptive Coding and Modulation
AMSA	Arctic Marine Shipping Assessment
ARTES	Advanced Research in Telecommunications Systems
ATC	Air Traffic Control
ATM	Air Traffic Management
BSS	Broadcasting Satellite Service
CASR	Central Arctic Shipping Route
CSA	Canadian Space Agency
DAMA	Demand Assigned Multiple Access
DC	Direct Current
DVB	Digital Video Broadcast
DVB-RCS2	DVB Return Channel via Satellite Second Generation
DVB-S2	DVB Satellite Second Generation
EGNOS	European Geostationary Navigation Overlay System
EIRP	Effective Isotropic Radiated Power
EPFD	Equivalent Power Flux Density
ESA	European Space Agency
ESV	Earth Station onboard Vessel
ETSI	European Telecommunications Standards Institute
EU	European Union
FDM	Frequency Division Multiplexing

FDMA	Frequency Division Multiple Access
FPSO	Floating Production, Storage and Off-loading
FSL	Free Space Loss
FSS	Fixed Satellite Service
GaAs	Gallium Arsenide
GEO	Geostationary Earth Orbit
GMDSS	Global Maritime Distress and Safety System
GPS	Global Positioning System
GSM	Global System for Mobile Communications
GTO	Geostationary Transfer Orbit
HDTV	High Definition Television
HEO	Highly Elliptical Orbit
HF	High Frequency
HPA	High Power Amplifier
IET	Department of Electronics and Telecommunications
IO	Integrated Operations
IOP	Initial Operational Phase
IP	Internet Protocol
ITU	International Telecommunication Union
LCF	Launch Cost Factor
LCV	Launch Cost Value
LDR	Low Data Rate
LEO	Low Earth Orbit
LME	Large Marine Ecosystems
LNB	Low Noise Block downconverter
M2M	Machine to Machine
MEO	Medium Earth Orbit
MF	Medium Frequency
MF-TDMA	Multi Frequency Time Division Multiple Access
MLP	Maneuver Lifetime Percent
MSS	Mobile Satellite Service

NAVTEX	Navigation Telex Radio
NEP	North East Passage
NextGen	Next Generation Air Transportation System
NMI	Norwegian Meteorological Institute
NSC	Norwegian Space Centre
NTNU	Norwegian University of Science and Technology
NWP	North West Passage
OBO	Output Back-Off
OBP	On Board Processing
PCW	Polar Communications and Weather
PhD	Philosophiae Doctor
PPP	Private Public Partnership
RAAN	Right Ascension of the Ascending Node
RF	Radio Frequency
SAR	Search and Rescue
SCPC	Single Carrier Per Channel
SDTV	Standard Definition Television
SESAR	Single European Sky ATM Research
SMS	Short Messaging Service
SSPA	Solid State Power Amplifier
STK	Satellite Tool Kit
TAP	Trans Alaska Pipeline
TDM	Time Division Multiplexing
TDMA	Time Division Multiple Access
TV	Television
TWTA	Travelling Wave Tube Amplifiers
UAS	Unmanned Aerial Systems
UHF	Ultra High Frequency
UN	United Nations

USA	United States of America
USGS	United States Geological Survey
VHF	Very High Frequency
VSAT	Very Small Aperture Terminal
WRC	World Radiocommunication Conference
XPD	Cross-Polarization Discrimination

References

- [1] K. Grythe, O. Gutteberg, I. Jensen, T. Røste, and H. E. Swendgaard, "Satellittkommunikasjon til nordområdene - en behovsundersøkelse," SINTEF IKT, Tech. Rep., February 2008.
- [2] B. Ellis and L. Brigham, Eds., *Arctic Marine Shipping Assessment 2009 Report*. Arctic Council, April 2009.
- [3] Euroconsult, MARINTEK, SINTEF ICT, Telenor, and Telesat, *Communications demands in the Arctic with a forecast for 2015 and 2020*. European Space Agency, February 2011.
- [4] J. E. Hakegard, T. Bakken, and T. A. Myrvoll, "User Requirements for HEO SATCOM for ATM in High Latitudes," in *2009 ICNS Conference*, May 2009.
- [5] K. Fjortoft *et al.*, "Analysis of Maritime Safety Management in the High North," September 2010, MarSafe project final report.
- [6] F. Bekkadal, "Emerging Maritime Communications Technologies," in *9th International Conference on Intelligent Transport Systems Telecommunications, (ITST)*, Lille, France, October 2009.
- [7] G. Maral and M. Bousquet, *Satellite Communications Systems*, 5th ed. John Wiley & Sons Ltd., 2009.
- [8] P. L. Smith, L. A. Wickman, and I. A. Min, "Future Space System Support to U.S. Military Operations in an Ice-Free Arctic: Broadband Satellite Communications Considerations," in *AIAA Proceedings*, September 2009.
- [9] A. P. Trishchenko and L. Garand, "Spatial and Temporal Sampling of Polar Regions from Two-Satellite System on Molniya Orbit," *Journal of Atmospheric and Oceanic Technology*, vol. 28, pp. 977–992, Aug. 2011.
- [10] A. P. Trishchenko, L. Garand, and L. D. Trichtchenko, "Three-Apogee 16-h Highly Elliptical Orbit as Optimal Choice for Continuous Meteorological Imaging of Polar Regions," *Journal of Atmospheric and Oceanic Technology*, vol. 28, pp. 1407–1422, November 2011.
- [11] J. R. Wertz, *Mission Geometry; Orbit and Constellation Design and Management*. El Segundo, California, USA: Microcosm Press, 2001.
- [12] J. Andenæs, "Identification of system critical parameters for high elliptical orbit satellites," June 2008, report written on contract from Norwegian Space Centre.

- [13] L. Løge, "Assessment of satellite constellations for arctic broadband communications," in *29th AIAA International Communications Satellite Systems Conference (ICSSC-2011)*, Nara, Japan, November 2011.
- [14] L. Løge, "Parametric evaluation of heo constellations supporting communications to the arctic," in *30th AIAA International Communications Satellite Systems Conference (ICSSC)*, Ottawa, Canada, September 2012.
- [15] V. Chobotov, *Orbital mechanics*, ser. AIAA education series. American Institute of Aeronautics and Astronautics, 2002.
- [16] D. F. Lawden, "Impulsive transfer between elliptical orbits," in *Optimization Techniques, with Applications to Aerospace Systems*, G. Leitmann, Ed. New York: Academic Press, 1962, ch. 11.
- [17] W. J. Larson and J. R. Wertz, Eds., *Space mission analysis and design*, 3rd ed. Torrance, Calif.: Microcosm Press, 1999.
- [18] O. Gutteberg, "Measurements of atmospheric effects on satellite links at very low elevation angle," in *AGARD Conference on radio wave propagation*, Spaatind, Norway, February 1984.
- [19] ITU-R, *Recommandation ITU-R P.676-8: Attenuation by atmospheric gases*. Geneva, Switzerland: International Telecommunication Union, October 2009.
- [20] T. Pratt, C. Bostian, and J. Allnutt, *Satellite Communications*. John Wiley & Sons Ltd., 2003.
- [21] L. J. Ippolito, *Satellite Communications Systems Engineering: Atmospheric Effects, Satellite Link Design and System Performance*. John Wiley & Sons Ltd., 2008.
- [22] ITU-R, *Recommandation ITU-R P.618-10: Propagation data and prediction methods required for the design of Earth-space telecommunication systems*. Geneva, Switzerland: International Telecommunication Union, October 2009.
- [23] ITU-R, *Recommandation ITU-R P.839-3: Rain height model for prediction methods*. Geneva, Switzerland: International Telecommunication Union, August 2001.
- [24] O. Gutteberg, "Low Elevation Propagation in High-Latitude Regions," Norwegian Telecommunications Administration Research Establishment, ESA contract report, April 1983.
- [25] ITU-R, *Recommandation ITU-R P.837-6: Characteristics of precipitation for propagation modeling*. Geneva, Switzerland: International Telecommunication Union, February 2012.
- [26] J. Mamen, R. Benestad, and J. E. Haugen, "Analysis of Short Term Precipitation in Norway 1967-2010," Norwegian Meteorological Institute, Report 15, December 2011.
- [27] O. Gutteberg, "Effects of atmosphere on earth-space radio propagation," *Teletronikk*, no. 4, pp. 63–70, 1992.
- [28] L. J. Ippolito, *Radiowave Propagation in Satellite Communications*. Van Nostrand Reinhold Company Inc., 1986.
- [29] ITU-R, *Recommandation ITU-R P.840-5: Attenuation due to clouds and fog*. Geneva, Switzerland: International Telecommunication Union, February 2012.
- [30] T. Tjelta and D. Bacon, "Predicting Combined Rain and Wet Snow Attenuation on Terrestrial Links," *IEEE Transactions on Antennas and Propagation*, vol. 58, no. 5, pp. 1677–1682, May 2010.

- [31] J. Farserotu and R. Prasad, "A Survey of Future Broadband Multimedia Satellite Systems, Issues and Trends," *IEEE Communications Magazine*, vol. 38, no. 6, pp. 128–133, June 2000.
- [32] J. N. Pelton, *Satellite Communications*. Springer, 2012.
- [33] B. R. Elbert, *Introduction to Satellite Communications*, 3rd ed. Norwood, MA, USA: Artech House, 2008.
- [34] ITU-R, *Radio Regulations*. Geneva, Switzerland: International Telecommunication Union, 2008.
- [35] M. J. Miller, B. Vucetic, and L. Barry, Eds., *Satellite Communications: mobile and fixed services*. Norwell, MA, USA: Kluwer Academic Publishers, 1993.
- [36] Joint Technical Committee (JTC) Broadcast, *ETSI TR 102 376: Digital Video Broadcasting (DVB) - User guidelines for the second generation system for Broadcasting, Interactive Services, News Gathering and other broadband satellite applications (DVB-S2)*. Sophia Antipolis, France: European Telecommunications Standards Institute, February 2005.
- [37] L. Løge and O. Gangaas, "Migrating Communications Services Towards Ka-band - From Trends to Focused Development," in *AIAA SPACE 2011 Conference and Exposition*, Long Beach, California, September 2011.
- [38] Joint Technical Committee (JTC) Broadcast, *ETSI EN 302 307: Digital Video Broadcasting (DVB); Second generation framing structure, channel coding and modulation systems for Broadcasting, Interactive Services, News Gathering and other broadband applications (DVB-S2)*. Sophia Antipolis, France: European Telecommunications Standards Institute, August 2009.
- [39] Joint Technical Committee (JTC) Broadcast, *ETSI EN 301 545-2: Digital Video Broadcasting (DVB); Second Generation DVB Interactive Satellite System (DVB-RCS2)*. Sophia Antipolis, France: European Telecommunications Standards Institute, January 2012.
- [40] A. Morello and V. Mignone, "DVB-S2: The Second Generation Standard for Satellite Broad-Band Services," *Proceedings of the IEEE*, vol. 94, no. 1, pp. 210–227, January 2006.
- [41] Joint Technical Committee (JTC) Broadcast, *ETSI TR 101790: Digital Video Broadcasting (DVB); Interaction channel for satellite distribution systems; Guidelines for the use of EN 301 790*. Sophia Antipolis, France: European Telecommunications Standards Institute, July 2009.
- [42] Joint Technical Committee (JTC) Broadcast, *ETSI TR 102 768: Digital Video Broadcasting (DVB); Interaction channel for satellite distribution systems; Guidelines for the use of EN 301 790 in mobile scenarios*. Sophia Antipolis, France: European Telecommunications Standards Institute, April 2009.
- [43] Nordurslodagattin ses - Arcticportal. Arctic Portal. [Online]. Available: www.arcticportal.org Last visited: 25.06.2012.
- [44] NOAA. Fisheries catch abundance in large marine ecosystems of the world: 2000-2004. [Online]. Available: www.lme.noaa.gov Last visited: 01.12.2010.
- [45] G. Nygård, "Hvordan kan konseptet Integreerte Operasjoner sikre god samhandling mellom fartøy og de øvrige partene i en offshore forsyningsklynge?" presented at the MarCom Conference, October 2010.

-
- [46] D. L. Gautier *et al.*, "Assessment of Undiscovered Oil and Gas in the Arctic," *Science*, vol. 324, no. 5931, pp. 1175–1179, May 2009.
- [47] BP Exploration Alaska, *BP in Alaska*. BP, August 2011. [Online]. Available: <http://alaska.bp.com>
- [48] State ATM Corporation of Russia, "Traffic," presented at 10th meeting of the Cross Polar Working Group, November 2010. [Online]. Available: http://www.faa.gov/about/office_org/headquarters_offices/ato/service_units/enroute/oceanic/cross_polar/
- [49] D. A. Cranstone, *A History of Mining and Mineral Exploration in Canada and an Outlook for the Future*. Minerals and Metals Sector, Natural Resources Canada, 2002. [Online]. Available: <http://publications.gc.ca/site/eng/117388/publication.html>

Appendix A

Published papers

Three papers have been presented and published at different conferences as part of the study and PhD work. These three papers are included on the following pages. The first paper is titled *Migrating Communications Services Towards K_a band – From Trends to Focused Development*, and was written together with Odd Gangaas at NSC. It was presented in a poster session at the *AIAA SPACE 2011 Conference and Exposition*. This conference took place in Long Beach, California, USA in September 2011. The paper address challenges and opportunities facing the commercial satellite communications industry as K_a band based systems becomes available on a large scale.

Paper number two is titled *Assessment of Satellite Constellations for Arctic Broadband Communications*. This paper was presented at the *29th AIAA International Communications Satellite Systems Conference (ICSSC-2011)*, held in Nara, Japan, in November 2011. That paper considered a number of different constellation alternatives for communications coverage of the Arctic. The constellation alternatives were assessed based on parameters important for satellite based broadband communications.

The third paper is titled *Parametric Evaluation of HEO Constellations Supporting Communications to the Arctic*, and was presented at the *30th AIAA International Communications Satellite Systems Conference (ICSSC-2012)* in Ottawa, Canada, September 2012. Also this paper considered and assessed a number of different constellations designed for communications coverage of the Arctic. However, this evaluation was more thorough. In addition to communications performance it also considered other properties including radiation environment, launch cost, frequency coordination and stationkeeping.

Migrating Communications Services Towards Ka-band - From Trends to Focused Development

Lars Loge*

Dept. of Electronics and Telecommunications, NTNU, Trondheim, Norway

Odd Gangaas†

Norwegian Space Centre, Oslo, Norway

This paper offers a roadmap and explores options toward new technology and system solutions, which provides both opportunities and challenges for the future of mobile satellite communications. Today global geostationary coverage on K_u-band is becoming a reality. K_a-band utilization represents the next step towards enhanced capacity. At present several satellite operators have implemented K_a-band capacity, and more operators have announced that new K_a-band satellites will be launched in the near future. This development will have a significant impact on satellite services and applications in the years to come. The paper first provides a historical perspective of some crucial technologies and key attributes in a satellite communications network. The physical boundaries of attributes such as noise figure, spectrum efficiency, coding and modulation are explored. Also discussed are the key technical requirements and considerations needed to turn the next generation satcom services into a commercial success. Secondly the paper looks at trends and future requirements in new systems, services and applications. The main focus is on the possibilities and hurdles that come with mobile satcom services offered at higher frequencies. The potential for smaller terminals, reduced cost and relevant system parameters when moving up in frequency are examined. The paper concludes by highlighting tradeoffs and identifying promising opportunities, that potentially can enhance the service offering and applications in alignment with identified market trends and requirements.

I. Introduction

This paper examines future challenges and possibilities facing the satellite industry in terms of systems and services using K_a-band. A brief walkthrough of technology and system developments that are setting the scene for future K_a-band system deployments is presented. The primary reference is geostationary satellite systems, but also other solutions are discussed as future trends and service requirements are highlighted. Main focus is directed towards mobile services and applications.

Mobile satellite communications (MSS) was first supported by L-band systems. For fixed services (FSS) C-band was the first frequency used, and it supported Trans Atlantic satellite communication and regional systems. C-band was also the frequency band used by feeder link stations in mobile satellite systems, such as Inmarsat. The need for enhanced FSS capacity swiftly matured K_u-band technology. This was supported by extensive propagation campaigns worldwide establishing knowledge necessary for reliable system design.¹⁻³

While L-band systems have matured to support services from handheld to data transmissions up to 0.5 Mbit/s, K_u-band has become the frequency band for broadcast services. Today space segment cost is strongly influenced by an attractive and overpopulated L-band for mobile satellite services, and a K_u-band driven by the broadcast market.

In mobile satellite communications K_a-band represents the next step for increased capacity. Although this has been envisioned for some years now, to point, adoption in the marketplace has been limited.^{4,5}

*Research Fellow, Dept. of Electronics and Telecommunications (IET), Norwegian University of Science and Technology (NTNU), NO-7491 Trondheim, Norway, AIAA Member.

†Senior Adviser, Norwegian Space Centre, P.O. Box 113 Skoyen, NO-0212 Oslo, Norway, AIAA Member.



Figure 1. Typical global maritime K_u -band coverage as offered by one particular service provider at present.

K_a -band coverage will have a significant impact on future services, applications and user equipment. The success of new solutions utilizing K_a -band will depend on the relationship between availability, performance and cost. In the current market there is a generally accepted assumption that large scale adoption of K_a -band will allow for increased performance at a reduced cost.

When addressing the potential and challenges of utilizing K_a -band, it is necessary to examine some critical technologies against physical boundaries. Knowledge of market drivers is critical for tailoring service packages to meet the needs of differing market segments. With this as a starting point, focus is set on opportunities and challenges ahead of us as K_a -band systems gain traction in the satellite communications business.

II. Coverage developments

Coverage is an important factor in the mobile satellite communications market. The commercial success of Inmarsat is a good example of the significant advantage of global coverage. While Inmarsat has offered global L-band service with coverage up to more than 70° latitude, K_u -band systems have primarily offered regional coverage solutions. With K_u -band operators focusing on broadcast services, data communications, especially for mobile applications, have typically only been an added revenue source for spectrum not yet needed for broadcast. As the mobile VSAT market has grown K_u -band operators have given it more attention, and the coverage has improved. However, the development has been slow with extended coverage limited to main shipping lanes. Figure 1 illustrate a typical example of coverage as offered by a service provider.

Broadcast services are still the driving force when it comes to K_u -band utilization. Mobile K_u -band communications are to a large extent an add-on on broadcast satellites. This is one of the reasons mobile service K_u -band coverage developments have been slow, and frequency coordination and spectrum availability is representing such a challenge. The satellite positions that are relevant are mainly driven by the broadcast segment leaving little spectrum to offer mobile satellite services. K_a -band has seen limited use for broadcast services. Thus, communications services offered in K_a -band are more independent of the broadcasting paradigm of K_u -band. This may alleviate the development and roll out of global mobile communications coverage in K_a -band.

With Inmarsat set to deploy their K_a -band coverage within a few years time, global K_a -band coverage similar to their L-band coverage is not far away. This double coverage will make Inmarsat well suited to support the broadband requirements of both the aeronautical and maritime industry. Hybrid solutions utilizing both L- and K_a -band will give Inmarsat an edge in the marketplace.

Inmarsat's move towards K_a -band is likely to spur other large satellite communications actors into action.

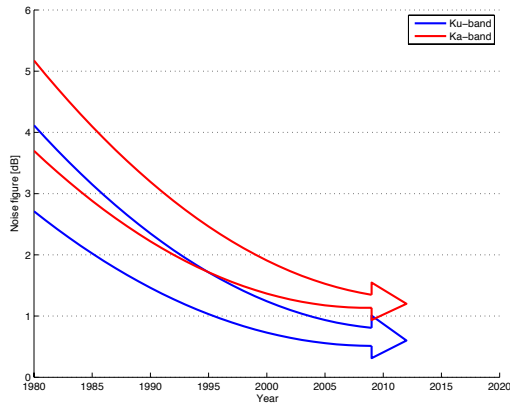

Figure 2. Illustration of noise figure development at Ku- and Ka-band during the last three decades.

Especially K_u -band satellite operators such as Intelsat which will need to develop their product portfolio in order to stay competitive in the new marketplace. Productive partnerships between service providers and system manufacturers will make K_u -band satellite operators fully capable of adequately enhancing their service offering. The recently announced partnership between Thrane & Thrane and Vizada is one such example. This partnership suggests innovative new hybrid solutions that will bring added value by combining the strengths and uses of K_u - and L-band technology. Such developments will evolve and change the mobile satellite communications industry in the coming years.

III. Present state of crucial technologies

This section is a survey of technologies that represent important building blocks in a satellite communications system. A characteristic difference between terrestrial and satellite based communications systems is the investment cost of infrastructure. In general terms, a communications satellite performs the same tasks as a terrestrial repeater, but the satellite has a much higher deployment cost. However, a satellite in geostationary orbit has the advantage of being visible from 44 % of the earths surface, and can be operated very efficiently. In order to benefit from this advantage, system designers must overcome challenges in power and spectrum utilization to create high quality links between users and satellites.

These challenges have made the satellite industry a front-runner in several aspects of communications technology. The satellite industry has been a driving force in the development of low noise receiver technology and coding and modulation solutions, developments important for the advancement of power and spectrum efficiency in communications. This can be illustrated by comparing satellite and cellular communications technology in the mid nineties. At that time satellite systems supported telephone connections at bit rates of 4.8 kbit/s with better voice quality than GSM, which operated with 13 kbit/s bit rates. This was achieved through the use of advanced voice coding, high performing low noise amplifiers and state of the art modulation and coding technologies.

In the last few decades we have experienced a stunning development in technology, components and products. Thirty years ago the rule of thumb for receiver noise figure was the square root of the operating frequency. With K_u -band that typically meant a noise figure in the vicinity of 3 dB to 3.5 dB. Today noise figure performance has reached levels around 0.6 dB. Correspondingly the K_a -band noise figure has improved from about 4.5 dB to 1.2 dB as illustrated in Figure 2.

This development has increased system performance levels significantly. However, as a result system performance has become more sensitive to effects that cannot be controlled. This is illustrated in Figure 3. The figure illustrates how rain has a larger relative impact on a system with a low noise figure. Adaptive Coding and Modulation (ACM) has been developed to handle situations where a communications link is degraded. The DVB-S2 specification is one such development.⁶ Notice in Figure 3 how the improvement in

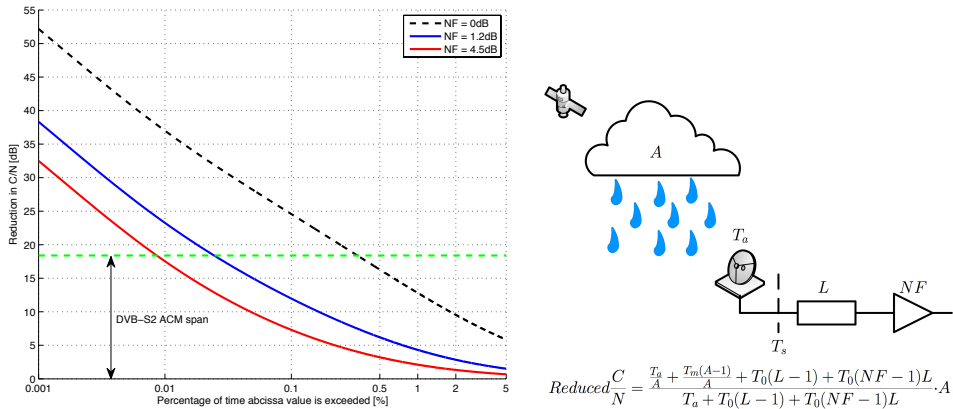

Figure 3. Illustration of the impact of rain on a Ka-band satellite downlink, and how it changes with noise factor. Rain attenuation, A , is calculated using ITU-R P.618-9, and is based on a rain intensity of 30 mm/h in 0.1% of the time. The line loss, L , has been set to 0.5 dB.

noise figure reduces the relative effectiveness of ACM in DVB-S2.

The improvement of noise figure has started to level out, and dramatic additional improvements from today's situation is not likely as we are getting closer to the physical boundary of 0 dB. Even though the noise figure will never reach 0 dB, small improvements at low levels will result in an increasing signal degradation with rain present in the signal path. As Figure 3 illustrates, improved ACM span is needed in systems designed with no margin in clear sky conditions.

Developments in modulation and coding technology, such as the DVB-S2, DVB-RCS and DVB-RCS2 specifications, have demonstrated operational performance levels close to Shannon's limit.^{6,7} This on top of improvements in voice and video coding technology has allowed new systems, services and applications that represent added value to the users.

Frequency spectrum is a limited resource. Reuse of frequency through employment of multiple spot beams has enhanced spectrum utilization with new and larger satellites. The evolution of the Inmarsat satellites exemplifies this well. First and second generation Inmarsat satellites were only equipped with global beams. Spot beams were introduced on the Inmarsat 3 satellites with five operational beams. Although the frequency reuse factor was less than two, improved EIRP and satellite G/T facilitated by the spot beams allowed smaller and cheaper terminals to be introduced into the market.

On the Inmarsat 4 satellites the number of spot beams has grown to about 200. Theoretically this will allow a frequency reuse factor of more than forty. For maximum frequency reuse the traffic has to be evenly distributed between the spot beams. This is generally not the case, thus, the actual frequency reuse factor is significantly less, probably under ten. The increased EIRP and G/T of the Inmarsat 4 satellites has made it possible for Inmarsat to add handheld services to their product portfolio.

The evolution of the Inmarsat system demonstrates that a larger and more advanced space segment can facilitate capacity improvement and market growth. However, there are practical limitations constraining this development, such as satellite and antenna dimensions and user distribution.

The satellite communications market is characterized by continuous growth and increasing demand for broadband solutions. More spectrum with extended capacity is required to meet these demands. For some time K_u -band has been available to the mobile satellite communications market. The next step necessary to facilitate future growth in the broadband demanding segment of the market is K_a -band.

Compared to K_u -band, K_a -band allows narrower antenna beams without increasing the antenna dimensions. However, this increased gain comes at a cost as the user terminal tracking and pointing requirements also increase. K_a -band is also more affected by rain, which has a profound impact on service availability. Furthermore K_a -band user terminal technology is not as mature as K_u -band. All these elements have impact on the overall system design, and must be considered carefully.

The first maritime VSAT systems provided communications to users by allocating a fixed capacity to each

individual user terminal. This solution was also used for mobile and maritime VSAT systems. Such an access scheme gives users guaranteed capacity and allows for customized applications. However, users then have to pay full price regardless of usage, and the satellite system has little flexibility when it comes to changes in market demand and needs. Shared access technologies, such as DVB-RCS, BGAN and iDirect, have been explored and implemented during the last decade. These technologies provide flexibility in capacity allocation and increase resource utilization at the trade-off against guaranteed capacity. Thus, high contention ratios and best effort services combined with users requiring always on and guaranteed bit rates still represent a challenge, and is an important focus area for future systems.

Both proprietary and standardized solutions for ACM has been explored and implemented. ACM provides the ability to counteract atmospheric propagation effects with high dynamic range, however the result is reduced bit rates. As illustrated in figure 3 the DVB-S2 standard allows a span in C/N of more than 18 dB. Integration of ACM into systems and alignment with service requirements remains a challenge. This is especially true at K_a-band due to its high dynamic range as shown in figure 3. Such systems are typically power constrained and operators might not utilize the full dynamic range.

IV. Trends and future requirements

During the last decade the telecom industry has been revolutionized. In just a few years the Internet and associated applications have penetrated the society and have been adopted by users worldwide. Terrestrial operators have focused on new and upgraded network infrastructure able to satisfy requirements of innovative services and applications. Optical fiber cable has to a large extent become the only solution able to realize adequate capacity in the terrestrial backbone network.

Commercial operators replacing the telemonopolies have brought forward competition in the telecommunication industry. As result low fixed monthly price plans for broadband access of several Mbit/s has become standard both for fixed wired services and mobile users. Terrestrial mobile service providers are today able to compete on both price and performance with wired service providers. It is based on this reference frame that the typical user states his performance and cost requirements for satellite services.

In this setting it is natural to ask where satellite communications belong, and what practical requirements are important to focus on for future satellite communications systems are.

Users that are out of range from terrestrial systems, have only satellite based systems available as viable solutions. This is predominantly the maritime and aeronautical market segments that are not able to keep up with the developments without using satellite communications. The land based satcom market also seems to be growing, but more as a supplement and extension to terrestrial systems. Satellite communication systems have actively demonstrated their value after disasters where the existing infrastructure has been destroyed or reliability is significantly reduced.

The satellite communications industry can be divided into two major categories, Mobile Satellite Services (MSS) and Fixed Satellite Services (FSS). Frequency allocations for mobile services are global, allowing a licensed operator to make the system design trade offs unrestrained. Allocations for mobile services are in L- and S-band, and the most important global providers are Inmarsat, Globalstar and Iridium.

Fixed services have allocations in C-band and upwards. FSS allocations are granted to operators for a certain geostationary satellite position. Satellites and users in FSS systems have to comply with regulatory restrictions ensuring that they do not produce harmful interference to neighboring satellites and systems. These regulations results in limitations on FSS systems and products, and reduce an FSS operator's system design options.

There is a rapid ongoing adoption of FSS-based system solutions in the mobile market. The increasing number of Maritime VSAT providers attest to this. For these systems the regulatory framework of FSS still apply and pose serious challenges to system designers. A promising approach that can alleviate these challenges and reduce terminal cost in mobile VSAT systems is to allocate MSS spectrum at higher frequencies. Such an initiative must be regarded as an interesting and important move for the satellite communications community.

The cost level for communications services in the MSS frequency bands has decreased significantly over the last decades. However, given the maturity of L-band technology and increasingly high demand for these types of services and applications, additional significant cost reductions cannot be expected. Mobile communications services in L- and S-band are unique in offering globally available and highly reliable services with a low user terminal investment cost. This makes it an ideal entry level service for new users of mobile

satellite communications.

MSS solutions represent an easy access to narrowband services for applications without volume intensive requirements. The market for these solutions is expected to increase in both value and importance in the future. Machine to machine (M2M) services, such as asset tracking and monitoring applications, are expected to increase the future MSS market. These new emerging services are assumed to determine the cost of communications capacity in L- and S-band in the future.

Therefore, in the long run the bandwidth hungry user segment cannot be supported satisfactorily by MSS systems. New systems and solutions operating in higher frequency bands comprise a necessary evolution. Firstly, it will provide cost efficient communication services to users with high bandwidth requirements. Secondly, it will offload the MSS systems ensuring adequate capacity for new products that can penetrate the evolving narrowband market segment.

Spread spectrum technologies have from time to time been proposed in various settings as a solution that will conform to the regulatory boundaries, and still allow employment of smaller terminal antennas. The idea is that by spreading the carrier power across a larger frequency band, the interference density to neighboring satellites is reduced. However, regulatory approval of a spread spectrum system is based on the aggregated power level of all active terminals. Thus, a spread spectrum based system will produce the same interference level as a non-spread spectrum system given equal performance to the same number of users and spectrum availability. This is the main reason there has not been a widespread adoption of spread spectrum technology in the satcom market.

There are exceptions where spread spectrum technologies are an effective tool in order to meet specific requirements. Examples can be found within military applications, where protection against detection and jamming is important, and low power dedicated systems. However, since such services and applications are not very spectrum efficient, they are not interesting for price sensitive users and the general commercial satellite communications market. Spread spectrum technology might be necessary for services with specific antenna size limitations.

Satellite systems have long lead-time. System design and satellite construction normally take several years. Depending on the complexity of the system and the number of satellites a commercial satellite operator typically needs three to five years from the initial design phase to reach operational status. Added to this comes the typical satellite lifetime of ten to fifteen years. Thus, system design choices made early in the process must make sense from a twenty year perspective. Satellite payload architecture and sizing is by no means a trivial issue. Market size, user distribution, pricing, investment cost and technology options have to be balanced to serve a business twenty years into the future.⁸

This long time horizon makes the satellite communications industry very conservative. However, it has also proven its ability to adapt and change with market requirements and conditions. The swift transition from analog to digital distribution of broadcast services in but a few years around 2000 is one example. Terrestrial broadcasting systems used several years to accomplish that transition. Another example is the adoption of FSS systems for maritime and mobile services. For many satellite operators these market adaptations were accomplished without a new satellite infrastructure. This ability to follow trends and respond to the market requirements will be crucial for the satellite communications industry also in the future.

Does a universal solution adaptable to all exist? Doubtfully, even the cellular mobile market, which for many years seemed homogeneous, is now diverging as tablets and other data only devices increase in popularity. Users have different requirements and constraints. Future systems must provide more than just standardized solutions. However, development of modular and flexible standards will allow reuse of technology. As the technology advances the cost will decrease and interest in niche optimized applications will increase. It will be paramount to standardize system solutions for the mass markets such as broadcast services and communications to the maritime and aeronautical segment. Standardization will reduce costs and ensure that the satellite industry stays competitive with terrestrial solutions competing also in these markets.

V. Possibilities and hurdles

This section takes a closer look at the possibilities and hurdles facing three user segments. First the maritime broadband segment is addressed, then the Arctic coverage gap. The third segment is dedicated systems.

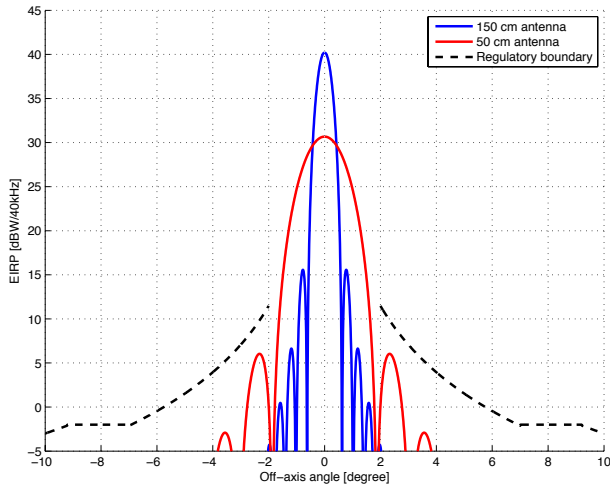

Figure 4. Illustration of antenna dimension impact on required pointing accuracy at 30 GHz. Observe how a larger antenna produce a narrower beam which is more prone to pointing errors. Exact shape and EIRP allowance of main lobe are coordinated between neighboring satellite operators. For illustration purposes the same terminal power level is used in both examples.

A. Maritime broadband

Maritime satellite communications terminals need antenna tracking functionality. Tracking requirements are not only given by ship maneuvers, but also ship movements enforced by the sea. Vessel size impacts tracking requirements as smaller vessels are more dynamic both pertaining to maneuvers and the effect of waves. Faster movements and larger range increase tracking requirements, which affect terminal cost.

The higher frequency of K_a -band enable increased antenna directivity compared to lower frequencies such as K_u -band. Thus, smaller antennas can be utilized, and still meet interference regulations. In ITU region 1 and 3 separation between geostationary satellites are at least 3° . Here maritime satcom terminal antennas down to 30 cm might conform to regulations. However, in ITU region 2 minimum satellite separation is only 2° , and hence 50 cm to 60 cm antennas are required for conformity with interference regulations.

With the global nature of maritime satellite communications solutions it must be expected that equipment with potential for global deployment will dominate the market. The regulatory framework of ITU region 2 therefore dictates a minimum maritime VSAT antenna dimension between 50 cm and 60 cm. Exact dimensions are subject to system trade-offs based on the cost efficiency of increasing tracking accuracy. The differences in pointing accuracy requirements for two different antenna sizes are illustrated in Figure 4. It is obvious that the narrow beam of a larger antenna is less tolerant to pointing errors.

System performance is, of course, also dependent on the space segment. However, larger terminal antennas and associated equipment are capable of supporting higher bit rates with the same space segment. Size of maritime VSAT equipment is limited by vessel construction, available vessel space and the terminal cost element. An increasing tracking accuracy requirement and a more demanding installation drives the terminal cost element upwards with antenna size. Figure 5 illustrates a characteristic relationship between traffic and equipment cost and antenna size and gain. Users must evaluate their requirements, and make a trade-off between traffic cost and equipment cost. K_a -band solutions for the maritime market are expected to use antennas significantly smaller than two meters. With a two meter antenna a pointing error of only a few tenths of a degree will result in a lost connection. A connection loss in a modern satellite system requires time consuming resynchronization, which reduces service availability even more. Trade offs between performance, cost and availability is therefore extremely important in K_a -band systems.

The maritime VSAT market operates with bundled pricing, where equipment and traffic costs are included in a fixed monthly price. Traditionally narrowband services in L-band have been billed per use. L-band and VSAT hybrid solutions are about to enter the marketplace adopting fixed price structures. This development

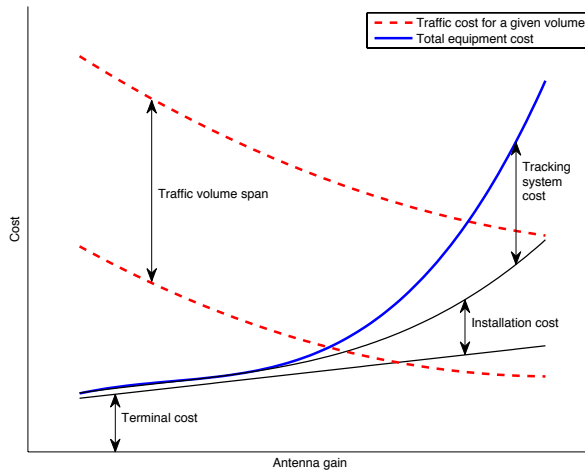

Figure 5. Distribution of equipment cost illustrated. As antenna gain increase pointing requirements increase, which require more advanced and costly tracking system. Larger antennas are also increasingly more complex to install, and thus increases installation costs. Higher antenna gain reduces necessary satellite power, which reduces traffic cost.

may move providers to offer fixed price solutions for L-band services as well. However, good pricing structures are a challenging focus area for the satellite communications industry.

One of the most severe challenges with K_a-band satellite communications is the impact of atmospheric attenuation, such as rain fading.⁹⁻¹¹ Adaptive coding and modulation technologies have been developed to counteract strong signal fading and increase service availability. As the attenuation increase more robust coding and modulation schemes are applied. The service gets increased availability, but throughput is significantly reduced. As discussed previously, modern receivers low noise figure increase the relative impact of rain, and enhance the importance of ACM solutions.

An alternative, or maybe a supplement, to ACM is to utilize systems at lower frequencies as backup when deep fading occur. Inmarsat can today provide services up to about 0.5 Mbit/s with high reliability, and charged on a per use basis. While traffic costs can be high, the equipment cost is low compared to VSAT systems. This makes L-band systems ideal as back up for VSAT systems. Integration of MSS and VSAT equipment into hybrid systems is a promising solution allowing service providers to meet user needs and requirements, both in terms of availability and coverage. Given the increased impact of rain this is especially valid for K_a-band systems.

B. Bridging the Arctic coverage gap

The Arctic region has limited communications coverage today. Low population density and large distances makes terrestrial infrastructure costly and inefficient, both to build and operate. Terrestrial communications solutions to end-users are typically only available in communities and settlements. Backbone services are usually provided by satellite, unless special requirements warrant higher capacity solutions such as fiber optical cable or radio links.

Geostationary satellites are only visible up to about 81° latitude. Due to various propagation effects at low elevation angles communications using geostationary satellites are not straight forward at these latitudes, which is especially challenging for maritime and mobile users. Reliable geostationary coverage is usually assumed to be limited to about 73° to 76° latitude.^{12,13}

The Iridium constellation is currently the only commercial satellite communications system with continuous coverage of the Arctic. Iridium provides voice and narrowband services through 66 satellites in low earth orbit. The regular service offer a basic data bit rate of 2.4 kbit/s. Channels can be bundled up to 128 kbit/s, but service performance depends on satellite capacity and availability at any given time. New im-

proved replacement satellites are under construction for Iridium. These new satellites will provide increased performance, but it is presently unclear to what extent. Nevertheless, physical limitations, such as spectrum availability, inhibit Iridium from providing services at the same performance level as geostationary satellites.

Over the years several studies have pointed to satellites in high elliptical orbits as the best solution for broadband coverage of the Arctic and high latitude regions.¹³⁻¹⁸ In Russia satellites in high elliptical orbits with around 63° inclination have been used for communications since the mid sixties. This series of satellites called Molniya, has given the name to its twelve-hour orbit. A constellation of two or three satellites in Molniya orbits are expected to provide the most cost efficient broadband communications system for the Arctic.

Design of a new satellite system for Arctic coverage can be approached through three strategies, the compatibility based, spectrum enhancing or the industry incubator approach.

The core of the compatibility based strategy is to design the Arctic system as an extension of geostationary systems. This means reuse of technology from geostationary systems that allow users to move between geostationary coverage and Arctic coverage more or less seamlessly. Advantages to this strategy include reduced need for users to install new and additional hardware, easier entry into the market place and possibility for truly global broadband services through roaming.

A spectrum enhancing strategy would be aimed at optimizing the use of the frequency spectrum. The idea is then to offer services not only in the Arctic, but also further South. That additional coverage will allow services to be moved from geostationary systems and make spectrum resources available. Maritime and mobile services can be moved as they already employ systems for satellite tracking. The available spectrum can then be used for new and more profitable services requiring geostationary coverage.

An incubator strategy is usually used by national governments, and the goal is to use the development of a new system to promote industry and increase its competitiveness. This approach might benefit the industry, but will often lead to system trades and design choices not consistent with an optimal Arctic communications system. The incubator strategy is mainly used in national or bilateral projects. An Arctic satellite communication system should, and will probably have to, be a multilateral project unsuitable for the incubator approach.

The compatibility strategy implies that design choices are locked to the complementary geostationary system, and system trade-offs are limited. Services and applications offered by an Arctic system must conform to those provided by geostationary satellites, and terminal design would be subject to the same regulatory framework. Selection of frequency bands depends on the compatible geostationary system. Until recently K_u-band would have been a natural choice, but Inmarsat and other operators have announced plans to launch K_a-band systems in a few years. The dry climate of the Arctic with little and low intensity rain makes K_a-band more power efficient in the Arctic than elsewhere. Thus, as potential compatible systems become available K_a-band should be given careful consideration for an Arctic system.

Important design choices and system trade-offs in the spectrum enhancing strategy depends on the services to be supported. The regulatory framework would be more relaxed as the strict geostationary regulations would not be applicable. This can open up for innovative terminal designs and more options in terms of frequency selection.

True global coverage is necessary today, and will be even more important in the future. Maritime and aeronautical activities are part of a growing global industry. Both ships and airplanes move between oceans and continents, and thus creating a global demand for communications services. The Arctic is no exception. In this setting an Arctic system design strategy promoting compatibility with geostationary systems and allowing for global roaming should be pursued.

C. Dedicated systems

Standardized solutions pave the way for competition in the marketplace, system synergies and large production volumes of equipment. The advantages are unquestionable as end user costs decrease. However, not all services and applications are suited for standardization. This can typically be anything from very specialized applications with low user volumes to services with special requirements necessary to support specific needs in a mass-market.

This paper presents only a few examples where technology, access schemes and frequency use are far from standardized, but still satisfy market segments and user requirements in a cost efficient way.

Supervisory Control And Data Acquisition (SCADA) applications are part of a general segment where standardization is not synonymous with cost efficiency. They usually need a high level of security, interface

with proprietary systems and have few terminals per system. One example is a system for remote monitoring and control of hydro electric dams, control of utilities systems and earthquake monitoring. The system relays information covering a range of parameters back to a control center. At the control center the information is digested and commands are returned to the remote system, such as open or shut the dam.

Another communications segment that is not necessarily suitable for standards such as DVB, iDirect or BGAN, is asset tracking and monitoring applications. Very small terminals fitted on containers, heavy machinery and other equipment provide owners with remote knowledge of position and condition of their material. The small terminals mean that only mobile frequency bands are usable. Requirements on transmit power and battery lifetime limits access scheme and network operation possibilities. In many situations standardized platforms are not able to operate within these limits. Skywave is one such solution that operates in L-band towards geostationary satellites providing small data packets with information about the assets. The system is designed to support a vast number of units with limited space recourses in order to be economically viable. Orbcomm provides a similar service using a constellation of low earth orbiting satellites operating in the VHF-band.

Asset tracking and monitoring applications are often labeled as machine to machine (M2M) communications. However, M2M applications are much more. For example on a vessel there might be a number of systems communicating with each other and on-shore control centers. Information and commands may flow both ways. Instead of equipping every unit with a small satellite link, the information is bundled and distributed by a single communications system, such as VSAT. Depending on the system requirements standardized solutions such as one based on DVB-RCS might be used, but in some cases dedicated and proprietary systems are better suited.

For the land mobile market, the automotive industry is also investigating the advantages of M2M applications. With M2M terminals installed in cars and vans maintenance and support schedules can be optimized and performed before parts are worn out, often referred to as predictive maintenance. Potentially it may also be possible to perform remote and automatic updating of software and firmware on vehicles. Constraints on terminal size, high number of units and need for cost efficient use of space dictate the need for dedicated and optimized solutions for such services.

Distress and safety services have very high requirements regarding availability and reliability. Both external and internal influences should have limited ability to hinder a distress call. A typical external influence is rain, while a typical internal influence is an inability to control the pointing direction of the antenna. These considerations have made the frequency bands of mobile satellite services the preferred way to support distress and safety services via satellite. Similar reasoning has led the EU and ESA in Europe and FAA in America to choose L-band instead of K_u - and K_a -band for support of the next generation Air Traffic Management (ATM) services.

Applications and market segments that are not exposed to the rain sensitivity of K_a -band are of particular interest for future K_a -band systems. One example is aeronautical broadband services. As flights are conducted above the clouds aeronautical broadband systems do not need margins to handle rain attenuation. The need for aeronautical broadband solutions was investigated early in the previous decade.¹⁹ However, experience has shown that it is challenging to align aeronautical satellite broadband services with in-flight operations, but it remains promising. Another example of a market segment not exposed to rain sensitivity is data relaying from other satellites such as earth observation satellites in LEO. Unmanned Aerial Vehicle (UAV) is often presented as a growing market for K_a -band systems due to the high bandwidth requirements. However, UAVs often operate at low altitudes where they have the same propagation challenges as other mobile satellite communications users.

VI. Conclusions

Some general conclusions can be drawn from the walkthrough in this paper. The conclusions are based on technologies and system solutions that has been discussed and explored, which provide both opportunities and challenges for the future development of satellite communications.

Global coverage of satellite communications services have for many years mainly been provided by L-band systems. In recent years global VSAT coverage in K_u -band has come close to reality for mobile application. The next step for increased capacity is utilization of K_a -band.

The large technology improvements over the last few decades expose new areas that needs to be addressed in future system design. Receiver noise figure performance along with coding and modulation technologies

are closing in on the physical boundaries. Implementation of ACM solutions has improved service availability, but as receiver noise figures decrease the relative effectiveness of ACM in an optimized system is challenged. At K_a -band power is more costly than spectrum resources, consequently cost efficient system designs using K_a -band have spectrum efficiency targets other than, for example, L-band systems.

MSS and FSS systems have different properties and operate under different regulatory frameworks. At the same time these two types of systems are increasingly operating in the same market segments. The satellite communications industry should in the future utilize the advantages of both types of systems in hybrid solutions, maximizing the performance and availability in a cost efficient manner. A form of mobile allocations in the lower part of K_u -band must be regarded as a interesting and positive move for the satellite communications industry, and such initiatives should be supported.

The higher frequency of K_a -band allow the use of smaller antennas without gain reduction, but the same pointing accuracy requirements apply. Due to interference regulations, the minimum mobile VSAT antenna dimension will be in the vicinity of 50 cm to 60 cm. Technology development facilitating cost efficient high performing mobile satellite terminals remains an important challenge for the satellite communications industry. When Inmarsat deploys their new K_a -band service, Global Xpress, it will become the benchmark for future global mobile satellite services.

Global coverage as defined by most service providers does not include the Arctic. Activity in the Arctic is increasing, expanding the need for broadband communication solutions. Future systems providing broadband coverage of the Arctic should be designed to be compatible with geostationary systems. With VSAT type services using K_u - or K_a -band available in the Arctic, true global roaming for the maritime communications market will be possible.

Market segments particularly promising for future K_a -band systems are aeronautical broadband and data relaying from LEO satellites. Systems and solutions can be designed power efficiently with high availability as they are not influenced by rain. The high bandwidth requirements of UAV systems makes K_a -band an interesting candidate for such applications. However, UAVs often operate at low altitude so rain sensitivity must be taken into consideration.

Market growth is increasingly being served by standardized solutions, but a solution does not exist that is adaptable to all applications and user segments. Existing and new applications unsuited for compliance with these standards need optimized solutions and platforms to be cost effective. These solutions can only be realized through focused development. Customer and market awareness along with technological knowledge will remain a fundamental asset to achieve future success in the satellite communications industry.

Acknowledgment

For valuable input, feedback and discussion during the preparation of this paper the authors would like to thank Fritz Bekkadal at the Norwegian Marine Technology Research Institute, Bjoern Barstad, Lars Erling Braaten at the Norwegian Defence Research Establishment, Paul Deedman and Hok Shuen Wong at Inmarsat plc, Arne Jorgen Maeland at Telenor Satellite Broadcasting, Catherine Melquist and Houman Samimi at Vizada Americas, Kjell Nohr at Jotron Satcom AS, Harald Skinnemoen at AnsuR Technologies AS, Prof.em. Gunnar Stette at the Norwegian University of Science and Technology and Terje Pettersen and Rune Sandbakken at the Norwegian Space Centre.

References

- ¹Arbesser-Rastburg, B. and Brussaard, G., "Propagation research in Europe using the OLYMPUS satellite," *Proceedings of the IEEE*, Vol. 81, No. 6, jun 1993, pp. 865 –875.
- ²Gutteberg, O., "Measurements of atmospheric effects on satellite links at very low elevation angle," *Teletronikk*, , No. 3, 1994.
- ³Stutzman, W., Pratt, T., Safaai-Jazi, A., Remaklus, P., Laster, J., Nelson, B., and Ajaz, H., "Results from the Virginia Tech propagation experiment using the Olympus satellite 12, 20 and 30 GHz beacons," *Antennas and Propagation, IEEE Transactions on*, Vol. 43, No. 1, jan 1995, pp. 54 –62.
- ⁴Barton, S. and Norbury, J., "Future mobile satellite communication concepts land mobile satellite systems," *Radiocommunications in the Range 30-60 GHz, IEE Colloquium on*, jan 1991, pp. 9/1 –9/6.
- ⁵Acosta, R., Bauer, R., Krawczyk, R., Reinhart, R., Zernic, M., and Gargione, F., "Advanced Communications Technology Satellite (ACTS): four-year system performance," *Selected Areas in Communications, IEEE Journal on*, Vol. 17, No. 2, feb 1999, pp. 193 –203.

- ⁶ETSI TR 102 376: *Digital Video Broadcasting (DVB) User guidelines for the second generation system for Broadcasting, Interactive Services, News Gathering and other broadband satellite applications (DVB-S2)*, 1.1.1 ed., February 2005.
- ⁷Alberty, E., Defever, S., Moreau, C., De Gaudenzi, R., Ginesi, S., Rinaldo, R., Gallinaro, G., and Vernucci, A., "Adaptive Coding and Modulation for the DVB-S2 Standard Interactive Applications: Capacity Assessment and Key System Issues," *Wireless Communications, IEEE*, Vol. 14, No. 4, august 2007, pp. 61 –69.
- ⁸Andersen, B. R., "On Design and Commercial Deployments of DVB-RCS Satellite Networks and Adaptation to Mobile Satellite Services," *1st SatLabs DVB-RCS Symposium - DVB-RCS has Taken Off*, September 2005.
- ⁹Arbesser-Rastburg, B. and Paraboni, A., "European research on Ka-band slant path propagation," *Proceedings of the IEEE*, Vol. 85, No. 6, jun 1997, pp. 843 –852.
- ¹⁰Rogers, D., Ippolito, L.J., J., and Davarian, F., "System requirements for Ka-band Earth-satellite propagation data," *Proceedings of the IEEE*, Vol. 85, No. 6, jun 1997, pp. 810 –820.
- ¹¹Crane, R. and Rogers, D., "Advanced Communications Technology Satellite (ACTS) propagation campaign in North America," *Antennas and Propagation Magazine, IEEE*, Vol. 40, No. 6, dec 1998, pp. 23 –28.
- ¹²Fjortoft, K., Kvamstad, B., Berg, T. E., Bekkadal, F., Haugen, T., Reiten, K., Nordlof, S., Klingsheim, J. M., Hall, R., Pedersen, G., Grythe, K., Jensen, I., Reinen, T. A., and Hellenen, O., "Analysis of Maritime Safety Management in the High North," MarSafe project final report.
- ¹³Bekkadal, F., "Emerging maritime communications technologies," *Intelligent Transport Systems Telecommunications, (ITST), 2009 9th International Conference on*, oct. 2009, pp. 358 –363.
- ¹⁴Hakegard, J., Bakken, T., and Myrvoll, T., "User requirements for HEO SATCOM for ATM in high latitudes," *Integrated Communications, Navigation and Surveillance Conference, 2009. ICNS '09.*, may 2009, pp. 1 –9.
- ¹⁵Smith, P. L., Wickman, L. A., and Min, I. A., "Future Space System Support to U.S. Military Operations in an Ice-Free Arctic: Broadband Satellite Communications Considerations," *AIAA SPACE 2009 Conference and Exposition*, September 2009.
- ¹⁶Kroupnik, G., "Polar Communications and Weather (PCW) / PolarSat Mission," *2nd Workshop on Satellite Imaging of the Arctic*, Quebec, Canada, September 2009.
- ¹⁷Maral, G. and Bousquet, M., *Satellite Communications Systems*, John Wiley & Sons Ltd., 5th ed., 2009.
- ¹⁸Andenaes, J., "Identification of system critical parameters for high elliptical orbit satellites," Report written on contract from Norwegian Space Centre.
- ¹⁹Jahn, A., Holzbock, M., Muller, J., Kebel, R., de Sanctis, M., Rogoyski, A., Trachtman, E., Franzrahe, O., Werner, M., and Hu, F., "Evolution of aeronautical communications for personal and multimedia services," *Communications Magazine, IEEE*, Vol. 41, No. 7, july 2003, pp. 36 – 43.

Lars Loge received a M.S. degree in electronics from the Norwegian University of Science and Technology (NTNU) in 2008. He is now a Research Fellow at the Dept. of Electronics and Telecommunications (IET) at NTNU. He also holds a position as Adviser in the Telecommunications section of the Norwegian Space Centre. His research interests include satellite communications with particular focus on the use of non-geostationary satellites for communications to the Arctic and high latitude areas.

Odd Gangaas received a M.S. degree in electronics from the Norwegian University of Science and Technology (NTNU) in 1980. From 2007 he has been a Senior Adviser at the Norwegian Space Centre in Oslo (NSC). Before joining NSC, Gangaas held positions with universities and industries such as NTNU, Marconi, Inmarsat and Telenor.

Assessment of Satellite Constellations for Arctic Broadband Communications

Lars Loge*

Dept. of Electronics and Telecommunications, NTNU, Trondheim, Norway

This paper presents several different satellite constellations able to provide communications coverage of the Arctic. The capabilities of the constellations are assessed based on parameters important for satellite based broadband communications. Currently GEO satellites provide close to global broadband communications coverage, but the Arctic is one of the exemptions. This issue is addressed here. Seventeen constellation alternatives have been assessed. Constellations with orbit periods of 12, 16, 18 and 24 hours have been used. Through evaluation of coverage, elevation and azimuth angle as well as other considerations it is concluded that a constellation consisting of three satellites in half sidereal day orbits and three planes with inclination of 63.4° is the favored solution.

I. Introduction

The Arctic has in recent years seen increased activity within all domains, ranging from aeronautical to maritime activities. Arctic activity is expected to continue its increase in the future. New shipping routes are being tested, and it has been estimated that 30 % of the world's undiscovered gas and 13 % of the world's undiscovered oil are in the Arctic.¹ These activities require communications services beyond what can foreseeable be supported by LEO systems, such as Iridium. Broadband and broadcasting services comparable to those available from geostationary satellites are examples of such requirements. The remoteness and lack of terrestrial infrastructure makes satellite based solutions the most cost effective way to provide broadband communications coverage to the Arctic.

Geostationary satellites can theoretically be visible up to 81° northern latitude. However, low elevation angles creates problems for satellite communications.² Mobile and maritime systems experience unstable service performance already from 72° to 75° north, depending on satellite position.^{3,4} Above 75° GEO satellites can be assumed unusable for broadband communications. This leaves a large part of the Arctic without coverage from geostationary satellites. A LEO system dedicated to Arctic communications will require many satellites with low utilization, and provide only a limited service offering. Such a solution is not cost effective.

The use of satellites in highly elliptical orbits (HEO) is a widely known and discussed solution for communications coverage of high latitude areas.⁴⁻¹⁰ A HEO satellite can provide quasi-stationary coverage of the Arctic in a large part of the orbit. With the right orbital parameters two HEO satellites is enough to provide continuous coverage of the Arctic and high latitude areas. In the following various satellite constellation alternatives are assessed to find the best solution for broadband communications coverage of the Arctic.

II. Constellation alternatives

Seventeen constellation alternatives have been assessed. For optimum performance the ground track should be recurring and have a high apogee altitude.^{5,9} Thus, constellations with orbit periods of 12, 16, 18 and 24 hours, adjusted down to coincide with the sidereal day, have been used. Orbital parameters for the assessed constellations are listed in table 1. The parameters have been adjusted and selected for coverage and minimum satellite dynamics as observed from ground.

*Research Fellow, Dept. of Electronics and Telecommunications (IET), Norwegian University of Science and Technology (NTNU), NO-7491 Trondheim, Norway.

Table 1. Summary of orbital parameters for the constellations assessed for Arctic coverage.

Name	Period [h]	Satellites [#]	Planes [#]	Inclination [°]	Eccentricity	Apogee altitude [km]	Perigee altitude [km]
12H2S1P	11.962	2	1	63.4	0.720	39 294	1 057
12H2S1P90	11.962	2	1	90.0	0.730	39 559	791
12H2S2P	11.962	2	2	63.4	0.720	39 294	1 057
12H2S2P90	11.962	2	2	90.0	0.730	39 559	791
12H3S3P	11.962	3	3	63.4	0.713	39 108	1 243
16H2S1P	15.956	2	1	63.4	0.530	42 853	8 745
16H2S1P90	15.956	2	1	90.0	0.530	42 853	8 745
16H2S2P	15.956	2	2	63.4	0.530	42 853	8 745
16H2S2P90	15.956	2	2	90.0	0.530	42 853	8 745
18H2S1P	17.951	2	1	63.4	0.410	42 698	14 157
18H2S1P90	17.951	2	1	90.0	0.410	42 698	14 157
18H2S2P	17.951	2	2	63.4	0.410	42 698	14 157
18H2S2P90	17.951	2	2	90.0	0.410	42 698	14 157
24H2S1P90	23.934	2	1	90.0	0.300	48 435	23 137
24H2S2P90	23.934	2	2	90.0	0.360	50 956	20 607
24H3S1P	23.934	3	1	63.4	0.265	46 960	24 613
24H3S3P	23.934	3	3	63.4	0.265	46 960	24 613

Two inclination alternatives have been given consideration. Inclination of 63.4° is used as it provide a stable orbit with no apogee drift. The other alternative is 90° inclination as that provides the highest elevation angles. However, HEO satellites with 90° inclination require frequent orbit corrections in order to maintain the apogee above the Arctic.

The number of orbital planes in a constellation have impact on positioning of the satellite ground tracks. In a constellation with one orbital plane all the satellites have individual ground tracks. The spacing between the ground tracks depend on orbit period and the number of satellites in the constellation. Identical ground tracks for all satellites in a constellation can be achieved when the number of orbital planes is equal to the number of satellites. In constellations with a single orbital plane, multiple satellites can be deployed by one rocket launch. This can save costs and is the main reason single plane constellations are considered.

Notation and how to interpret the name of the constellations listed in table 1 should be fairly self-explanatory. Constellation names consists of approximate orbit period in hours, number of satellites and number of orbit planes. At the end of the name inclination is appended when it is not 63.4°.

III. Coverage

As mentioned, mobile and maritime broadband communications using geostationary satellites is unstable above 72° to 75° northern latitude.^{3,4} Furthermore, power requirements and sensitivity to fading as well as shadowing increase with decreasing elevation angles. A satellite system designed to provide broadband communications to the Arctic must therefore at least have coverage of the area above 72°N. It would also be beneficial to have some coverage overlap between geostationary systems and an Arctic satellite system to facilitate roaming and handover between systems. A coverage requirement of the area above 60°N is suggested and used in this assessment. This ensures reliable communications coverage of the border zone, and increases the market potential of an Arctic satellite communications system.

In figure 1 simulated coverage time percent for all the assessed constellations are shown as a function of latitude. The latitude from which continuous coverage is ensured ranges from about 10° to 60°N for the various constellations. Only one constellation will not meet the defined coverage requirement. That is the alternative with 18 h orbit and two satellites in separate orbital planes (18H2S2P). However, as figure 1 show this constellation is very close to meeting the coverage requirement. Nevertheless, constellation 18H2S2P is removed from further consideration.

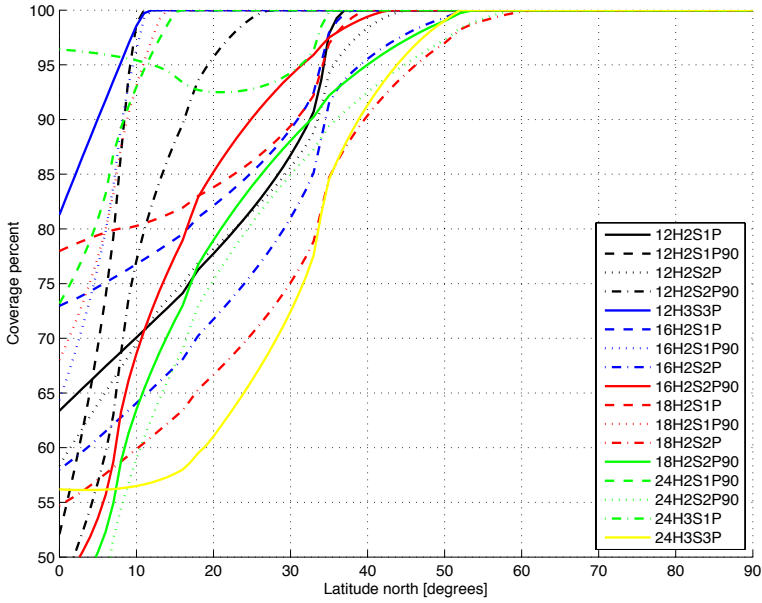

Figure 1. Coverage time percent provided by the various constellations as a function of latitude.

IV. Elevation angle considerations

Satellite communications at low elevation angles is challenging due to the increased path length through the atmosphere. The increased path length through the atmosphere increases the atmospheric attenuation and rain fades can become more severe. Multi path fading and scintillation effects can also reduce the performance of a satellite communications link at low elevation angles. It is, among others, these effects that makes mobile and maritime satellite broadband communications with geostationary satellites unstable higher than 72° to 75° north. Thus, a minimum elevation angle requirement between 5° to 10° is appropriate.

In the southern part of the coverage requirement used in this satellite constellation assessment, geostationary satellites are available at elevation angles in excess of 20° . Thus, to be competitive in this area, an Arctic satellite broadband communications system should have a minimum elevation angle requirement of 10° .

Simulations for the worst case position for the various constellation alternatives show that most of them meet this requirement. However, three of the sixteen remaining alternatives will for short periods give elevation angles below the 10° requirement at the worst case position. These three are 16H2S2P, 18H2S2P90 and 24H2S2P90, and they are removed from further consideration.

V. Azimuth angle considerations

The azimuth angle from a user terminal towards a satellite is important. This is especially true for systems with directional user terminal antennas, such as VSAT solutions. For all the constellations considered here the direction to an active satellite is not constant. Some of the constellation alternatives are designed to reduce and minimize the need for line of sight in multiple directions. However, several of them have constantly changing azimuth and require substantial change in pointing direction when moving traffic between satellites. The changes in azimuth angle discussed here are caused by the dynamics of the system as experienced by a non-moving user.

For mobile and maritime users the need for a wide line of sight can be a constraint on communications. On a ship or vessel, space suitable for satellite antenna placement is limited. As a result 360° line of sight

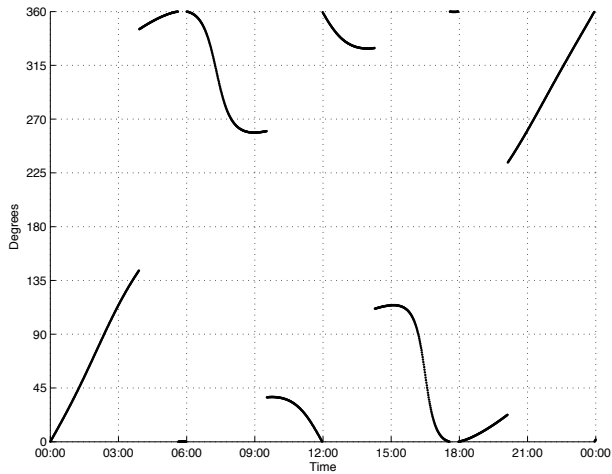

Figure 2. Example of how azimuth angle typically changes over the course of a day for the 12H2S1P90 constellation as seen from a user terminal. This example is with a user terminal located close to Longyearbyen at Svalbard, Norway.

for a maritime satellite communications antenna is a challenge and sometimes not possible. Vessels can experience periods of communication outage if a satellite is blocked by land, buildings or other structures. A constellation design that result in much terminal antenna movement in azimuth facilitate such outages. Thus, excessive change in azimuth angle should be avoided if possible.

Another issue with azimuth angle is at traffic handover between satellites. Most mobile and maritime users will have only one terminal antenna. This makes seamless handover possible only with constellations where incoming and outgoing satellite are within the terminal antenna beam. Even then seamless handover will be a challenging feature to implement. Some of the constellations require full readjustment of the terminal antenna azimuth angle. For these constellations seamless handover is not possible, and realtime services such as voice will be terminated at handover. These constellations may also create line of sight problems at handover with the same effect as discussed above.

The constellations utilizing orbits with 90° inclination will sweep across the sky. For all these constellations a user will experience change in azimuth angle of more than 180° while following a satellite. In addition to this, repointing of the antenna is necessary at all handovers. Figure 2 illustrate an example of how the azimuth angle changes over the course of a day for the 12H2S1P90 constellation. Even though some of these constellations can offer minimum elevation angles above 40° , it does not compensate for the disadvantage of variation in azimuth angle. The six constellations 12H2S1P90, 12H2S2P90, 16H2S1P90, 16H2S2P90, 18H2S1P90 and 24H2S1P90 are therefore removed from further consideration.

The remaining seven constellation alternatives all utilizes orbits with inclination of 63.4° . Azimuth angle variation from user terminal towards a satellite are less than 20° for all these seven constellations. This is illustrated in figure 3 using the 12H2S1P constellation as example. Potential exceptions to this are terminals positioned from 60° to 63.4° and close to the satellite ground track. However, these users will in periods with large changes in azimuth have elevation angles close to 90° . At high elevation angles changes in azimuth angle is a negligible issue.

Five of these seven constellations require antenna repointing at handover, while two of them require no repointing. 12H3S3P and 24H3S3P require line of sight in only one general direction. This is illustrated in figure 4. 12H2S2P require terminal antennas to turn up to 180° between two general directions twice a day. 16H2S1P and 24H3S1P switches between three general directions up to 120° three times a day. 12H2S1P will necessitate handover with substantial change in azimuth angle four times a day, in four general directions up to 90° apart as illustrated i figure 3. The last constellation, 18H2S1P, needs line of sight in eight general directions, and moves three times a day in steps up to 135° . For all practical purposes 18H2S1P requires

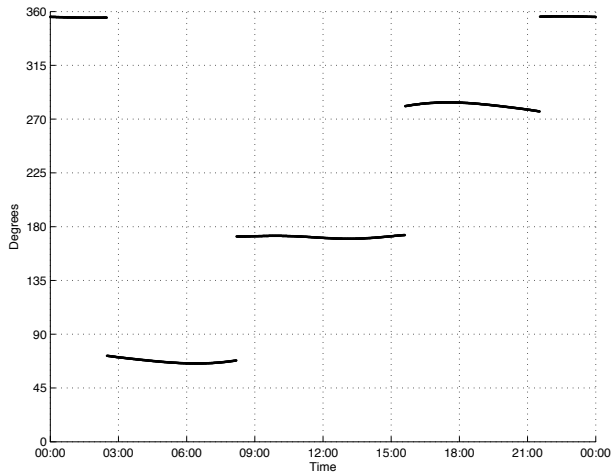

Figure 3. Example of how azimuth angle typically changes over the course of a day for the 12H2S1P constellation as seen from a user terminal. This example is with a user terminal located at Eureka in the Canadian Arctic Archipelago.

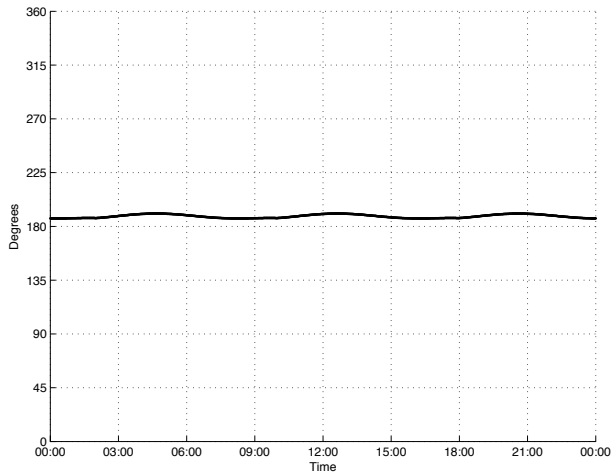

Figure 4. Example of how azimuth angle typically changes over the course of a day for the 12H3S3P constellation as seen from a user terminal. This example is with a user terminal located close to Longyearbyen at Svalbard, Norway.

antenna line of sight in 360° , and is therefore removed from further consideration. 24H3S1P is also removed from further consideration as it has similar performance as 16H2S1P, but requires an additional satellite in the constellation.

As 12H3S3P and 24H3S3P provide quasi-stationary satellite conditions they are more suitable for broadband communications than the rest. However, these two alternatives have the disadvantage of using one satellite more than the other alternatives. Thus, the argument can be made that it might be more cost efficient to equip the users with continuous real time requirements with an additional antenna. That will allow simultaneous pointing towards two satellites, and paves the way for seamless handover between satellites.

In that case, 12H2S2P is the third best candidate constellation in terms of azimuth angle implications as it only moves between to general directions at handover. However, if repointing at handover is acceptable both 12H2S1P and 16H2S1P are also viable alternatives.

VI. Other considerations

12H2S1P, 12H2S2P and 16H2S1P can only be viewed as candidates if antenna repointing at handover is accepted. None of these alternatives distinguishes themselves from the others in terms of coverage, free space loss or signal delay. There is one large difference, and that is the radiation environment the satellites in the different constellations will be exposed to. 12H2S1P and 12H2S2P constellations will pass through the Van Allen radiation belts four times a day. Such radiation exposure significantly reduces satellite lifetime.^{11,12} The satellites in a 16H2S1P constellation will however avoid the most damaging radiation areas, and hence have substantially longer life expectancy. It is therefore assumed that the 16H2S1P constellation will be the most cost efficient and favored of these three alternatives.

Of the two alternatives providing quasi-stationary satellite conditions, the 12H3S3P constellation has the advantage that two satellites at any time is available within the coverage area. This allow for redundancy, load sharing and space diversity. With full dual coverage and load sharing the total satellite capacity can be utilized more effectively. The result can be smaller and more cost efficient satellites compared to the 24H3S3P constellation.

There are small differences in worst case free space loss and signal roundtrip delay between the two constellation alternatives. 24H3S3P has approximately 1.6 dB higher free space loss and about 60 ms longer round trip signal delay. With total free space loss in the range of 180 dB to 210 dB, depending on frequency used, and total signal delay around 300 ms these differences are not significant.

Satellite lifetime is however a significant issue in this setting. The satellites in a 12H3S3P constellation will have to pass through the Van Allen radiation belts four times each day. Satellites in a 24H3S3P constellation will not be exposed to the same harsh radiation environment. It has been claimed that the radiation satellites in 12 h HEO orbits are exposed to typically limits satellite lifetime to about seven years.^{9,10} However, there are good reasons to believe that modern radiation hardening techniques can improve satellite lifetime significantly.

Due to the possibility for smaller satellites as well as significantly lower launch cost it is assumed that the 12H3S3P constellation will allow for the most cost efficient and flexible quasi-stationary system solution. Thus, the 12H3S3P constellation is assessed to be the favored alternative.

VII. Conclusions

Several constellation alternatives have been simulated to assess how they are capable of supporting broadband communications in the Arctic. Through evaluation of coverage, elevation and azimuth angle as well as other considerations it is concluded that a constellation consisting of three satellites in half sidereal day orbits and three planes with inclination of 63.4° is the most favorable. It has the ability to provide continuous coverage of the the whole Arctic down to 60° northern latitude from two satellites. Additionally handover between satellites do not require repointing of user terminal antennas.

Acknowledgment

This work has been performed as part of a Ph.D study at the Norwegian University of Science and Technology (NTNU) under the supervision of Prof. Odd Gutteberg. The author would like to thank Odd Gangaas, Terje Pettersen and Rune Sandbakken at the Norwegian Space Centre for support and valuable feedback during the research and preparation of this manuscript.

References

¹D. L. Gautier, K. J. Bird, R. R. Charpentier, A. Grantz, D. W. Houseknecht, T. R. Klett, T. E. Moore, J. K. Pitman, C. J. Schenk, J. H. Schuenemeyer, K. Sorensen, M. E. Tennyson, Z. C. Valin, and C. J. Wandrey, "Assessment of undiscovered oil and gas in the arctic," *Science*, vol. 324, no. 5931, pp. 1175–1179, May 2009.

²O. Gutteberg, "Measurements of atmospheric effects on satellite links at very low elevation angle," in *AGARD Conference*

on radio wave propagation, Spaatind, Norway, February 1984.

³K. Fjortoft, B. Kvamstad, T. E. Berg, F. Bekkadal, T. Haugen, K. Reiten, S. Nordlof, J. M. Klingsheim, R. Hall, G. Pedersen, K. Grythe, I. Jensen, T. A. Reinen, and O. Hellenen, "Analysis of Maritime Safety Management in the High North," September 2010, MarSafe project final report.

⁴F. Bekkadal, "Emerging Maritime Communications Technologies," in *9th International Conference on Intelligent Transport Systems Telecommunications, (ITST)*, Lille, France, October 2009.

⁵G. Maral and M. Bousquet, *Satellite Communications Systems*, 5th ed. John Wiley & Sons Ltd., 2009.

⁶J. E. Hakegard, T. Bakken, and T. A. Myrvoll, "User Requirements for HEO SATCOM for ATM in High Latitudes," in *2009 ICNS Conference*, May 2009.

⁷A. P. Trishchenko and L. Garand, "Canadian Polar Communication and Weather (PCW) satellite system: New capabilities for mapping Arctic snow and ice dynamics from Highly Elliptical Orbit," in *6th EARSeL Workshop*, Berne, Switzerland, February 2011.

⁸P. L. Smith, L. A. Wickman, and I. A. Min, "Future Space System Support to U.S. Military Operations in an Ice-Free Arctic: Broadband Satellite Communications Considerations," in *AIAA Proceedings*, September 2009.

⁹A. P. Trishcheko and L. Garand, "Three Apogee 16-h Highly Elliptical Orbit As Optimal Choice For Continuous Meteorological Imaging Of Polar Regions," *Journal of Atmospheric and Oceanic Technology*, submitted for publication 2011.

¹⁰G. Kroupnik, "Polar Communications and Weather (PCW) / PolarSat Mission," in *2nd Workshop on Satellite Imaging of the Arctic*, Quebec, Canada, September 2009.

¹¹W. J. Larson and J. R. Wertz, Eds., *Space Mission Analysis and Design*, 3rd ed. Microcosm Press, 1999.

¹²J. R. Wertz, *Mission Geometry; Orbit and Constellation Design and Management*. El Segundo, California, USA: Microcosm Press, 2001.

Lars Loge recieved a M.S. degree in electronics from the Norwegian University of Science and Technology (NTNU) in 2008. He is now a Research Fellow at the Dept. of Electronics and Telecommunications (IET) at NTNU. He also holds a position as Adviser in the Telecommunications section of the Norwegian Space Centre. His research interests include satellite communications with particular focus on the use of non-geostationary satellites for communications to the Arctic and high latitude areas.

Parametric Evaluation of HEO Constellations Supporting Communications to the Arctic

Lars Loge^{*}

Dept. of Electronics and Telecommunications, NTNU, Trondheim, Norway

This paper address satellite constellation alternatives for broadband communications coverage of the Arctic and high latitude areas. Currently, Iridium is the only commercially available satellite communications system outside GEO coverage, and it does not support broadband services of the type provided by GEO systems. A constellation of quasi-stationary satellites in highly elliptical orbits (HEO) would be ideal for provision of such services to the Arctic and high latitude areas. The paper first look at orbit alternatives and investigate the effect a non-critical inclination has on the argument of perigee. An inclination higher than 63.435° is found to be a realistic option only for HEO satellites in 24 h orbits. The results from an evaluation of 15 constellation alternatives which have been assessed on ten key performance properties are presented. A constellation of two 16 h HEO satellites in the same orbital plane was evaluated to have a good overall performance. Especially radiation environment and stationkeeping performance is advantageous with a 16 h orbit constellation compared to 12 h orbit alternatives. However, it is assumed to be possible to mitigate the impact of these effects on satellite lifetime through the use of appropriate shielding and modern technology. A constellation alternative with three 12 h HEO satellites in individual orbital planes should be favored because of its superior communications specific performance, given that it can be implemented at an acceptable cost.

Is not included due to copyright

Appendix B

Arctic activities

In 2008, SINTEF IKT surveyed the communications needs in the northern and high latitude regions as part of a study contracted by NSC. The study concludes that a wide range of users in the Arctic needs improved solutions for communications [1]. Those conclusions were further strengthened in 2011 by the ESA contracted ArctiCom study [3]. Activities in the Arctic can be categorized in three general groups:

- Maritime activities
- Aeronautical activities
- Land based activities

Within these categories, there are many different types of users. Different user types have their demands and requirements, but the fundamental communications challenges in a category have similarities. A summary providing a general understanding of the various activities in the Arctic and high latitude regions is provided here. The categories listed above, with subgroups, are considered and discussed. Some thoughts on the future development of Arctic activities are also presented.

B.1 Maritime activities

The maritime activities category encompasses everything that takes place offshore. Large contributors here are fishing industry, transportation, petroleum industry and governmental services. A brief summary of the various maritime

activities is given here. The focus is on the users geographical location and their typical communication requirements in the Arctic.

B.1.1 Fishing industry

Fishing vessels operating in the Arctic ranges from small boats with a crew of one to large factory ships with a large crew. The smallest fishing vessels stay fairly close to land, and are out to sea only for a few days at a time. Large factory ships can have extensive on-board facilities for processing and freezing of the catch. This allows them to be at sea for several weeks at a time. For the smallest vessels, the communications requirements are limited to emergency use and weather reports. As they operate close to shore, they are usually within the range of coastal VHF stations. Those who operate on the edge and outside VHF coverage can benefit from satellite based GMDSS coverage.

The large factory ships will normally operate far from the shore and land based infrastructure. Satellite systems are, therefore, necessary for communications. With large crews and long periods at sea, the communications requirements extends past emergency use and weather reports. Operational information, such as position and catch reports, needs to be dispatched to land. Updates of navigation systems with electronic charts and ice information is also necessary. When at sea for long periods at a time, the crew demands internet access for communications with family and friends as well as for entertainment. Access to broadcasting services is also desirable.

In 2009, the Arctic Council issued the Arctic Marine Shipping Assessment (AMSA) report. According to the report, fishing vessel activity in the Arctic is limited to a few key geographical areas. Above 70° North, those areas are the Barents sea, west coast of Greenland and north of Iceland. The fishing activity is low in the Arctic Ocean and Canadian Arctic Archipelago. It is mainly limited to small scale food fisheries and local population. This is also the case for Russian Arctic waters [2]. In Figure B.1, indications on the fisheries catch abundance of the Large Marine Ecosystems (LME) in the Arctic is shown. The areas with high activity also have high catch abundance [43,44].

B.1.2 Transport

Maritime transport is a diverse group. It ranges from cargo vessels to passenger vessels. Bulk and ore freighters, tankers, container ships and RoRo

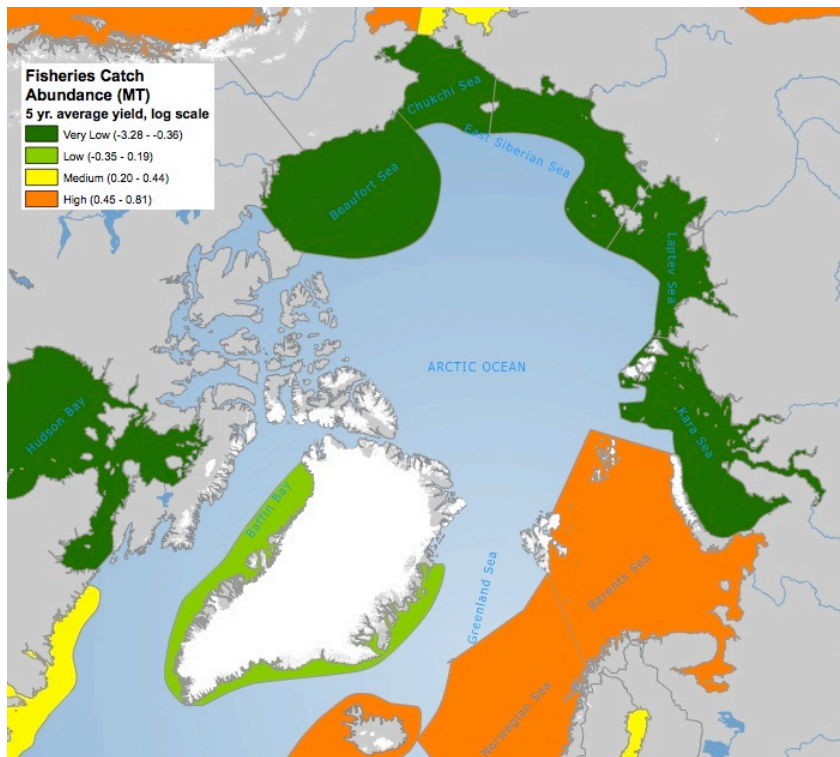

Figure B.1: Fisheries catch abundance in the LME of the Arctic [43, 44].

ships fall into the cargo category. Cruise ships, exploration vessels, ferries and research vessels are in the passenger category. These vessels can be fairly large ocean going ships, usually out at sea for several days at a time. Thus, in addition to distress and safety, a communications system is required for updating navigation systems with electronic charts and ice information. In-fotainment for crew and passengers in terms of internet access, phone and television is also in demand. Shipping and cargo companies are also interested in cargo tracking and exchange of logistics information between shore based facilities and the vessels. Small coastal based vessels can also be put in this group. Those vessels will not venture far from land and are usually in port at night. Their communications requirements are, therefore, mainly limited to emergency use and services available through land based infrastructure.

Maritime transportation in the Arctic is dominated by destination and intra-Arctic sailings. Ships are used for community resupply and for transport of products, such as oil, gas, coal and ore, from sites where natural resources are exploited. These operations are mostly completed in the summer and early



Figure B.2: Illustration of Arctic sailing routes. The NEP is north of Russia and the NWP is north of Alaska and through the Canadian Arctic archipelago. In the middle is the potential future CASR [43].

fall in order to avoid the worst winter and sea ice conditions. During winter time, maritime activity in the Arctic is usually limited to ice free areas. The locations of Arctic communities and settlements are discussed in section B.3 about land based activities.

The last decade has seen a noticeable decrease in the extent of the Arctic sea ice minimum. That has sparked new interest in using the North East Passage (NEP) and the North West Passage (NWP) as sailing routes between the North Atlantic and northern Pacific. The shipping routes are illustrated in Figure B.2. A possible future Central Arctic Shipping Route (CASR) is also drawn on the map, but it is not a realistic route for the time being [43]. At the moment and in the near term future, use of NEP and NWP are only possible for a short period each year, in late summer and early fall. However, should the observed development of ice extent continue, that window will expand.

If commercial shipping companies in the future start using the Arctic sailing routes, the communications volumes in these areas will increase drastically. With increased activity, availability of reliable distress and safety systems will also grow in importance.

B.1.3 Offshore petroleum industry

The offshore petroleum industry encompass a wide range of activities. In the exploration phase, seismic vessels and exploration rigs are employed. On operational fields, production platforms, Floating Production, Storage and Off-loading (FPSO) vessels and subsea installations are used for production. In addition, a large logistics operation is required both in the exploration and production phase. Equipment, supplies and people must be moved between land and installations, and oil and gas need to be transported to refineries and users with tankers or through pipelines.

Requirements to communications services and applications from the offshore petroleum industry are for all practical purposes the same in the Arctic as everywhere else. The biggest difference being the need for accurate and updated ice information. Most of the vessels employed in the petroleum industry today use maritime broadband services. In addition, they may be equipped to receive broadcasting services. GMDSS is of course a necessity.

A concept used in the petroleum industry to increase efficiency and productivity is Integrated Operations (IO). IO uses communications and exchange of information to support operations from shore. This reduces downtime due to accidents and unplanned maintenance. Offshore crew composition is also optimized as computer operators are moved onshore. An IO capable production rig typically require a bandwidth in the order of 20 Mbit/s in both directions. In the North Sea, these requirements are met by a fiber optical network between installations and land. Installations without fiber cable are connected to other installations with radio links. Logistics operations can also benefit from IO, but currently this is not fully implemented. It has been estimated that integration of logistics vessels will require a bandwidth in the order of 2 Mbit/s to 4 Mbit/s, and that is usually not available on logistics vessels [45].

Studies published in Science suggests that of the undiscovered hydrocarbon reserves in the world up to 30 % of the gas and 13 % of the oil can be found in the Arctic. The maps in Figure B.3 and B.4 show the United States Geological Survey (USGS) assessment of petroleum resources in the Arctic [46]. Areas with assumed large petroleum resources are of great interest to the petroleum

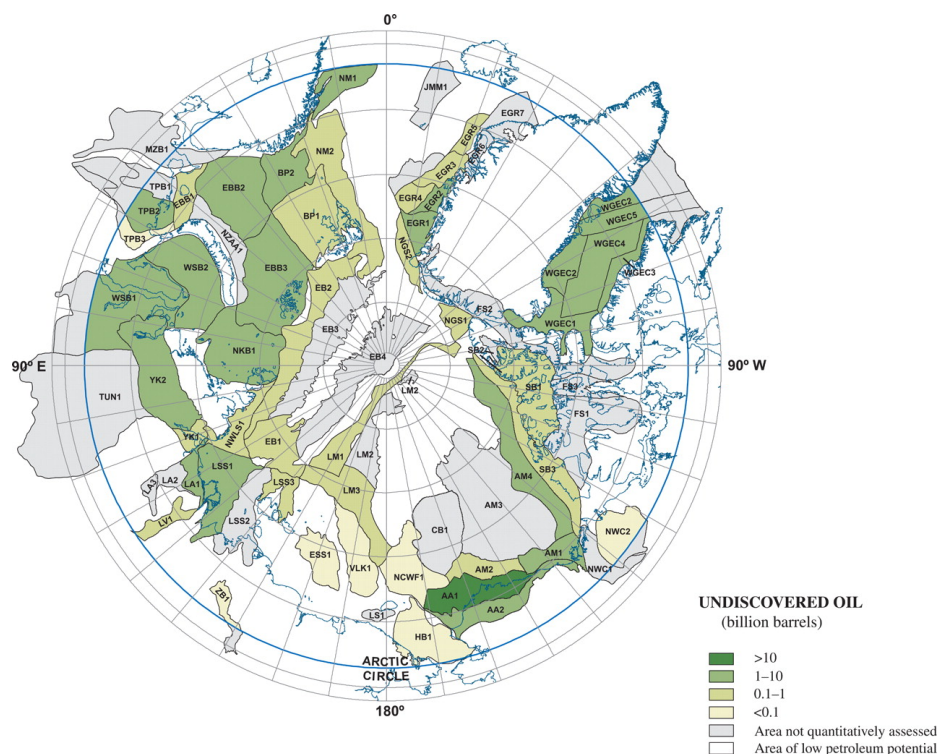

Figure B.3: Undiscovered oil reserves in the Arctic as assessed by USGS [46].

industry. So far, only a few areas in the Arctic have been opened for the petroleum industry. On the Alaskan North Coast there are a few offshore installations. However, they are placed on artificial islands in shallow waters close to shore and connected to land by causeways and subsea pipelines. All the oil produced in the North Slope of Alaska is transported to Valdez on the Alaskan South Coast through the Trans Alaska Pipeline (TAP) [47]. Thus, ground based infrastructure are able to satisfy most of the communications needs in this area. The exception is during the exploration phase when vessels and temporary installations are used.

On the Russian side of the Arctic, there is at present some exploration and production activities on and around the Yamal peninsula and in the Kara Sea. The production in this area is mostly gas, and it is transported southwards in pipelines. Development of the Stohkman gas field west of Novaya Semlya is under consideration, and it will bring increased activity to the area in the future. In the Norwegian sector, the offshore gas field Snow White is in production, but the production facilities are shore based and close to the mainland. The

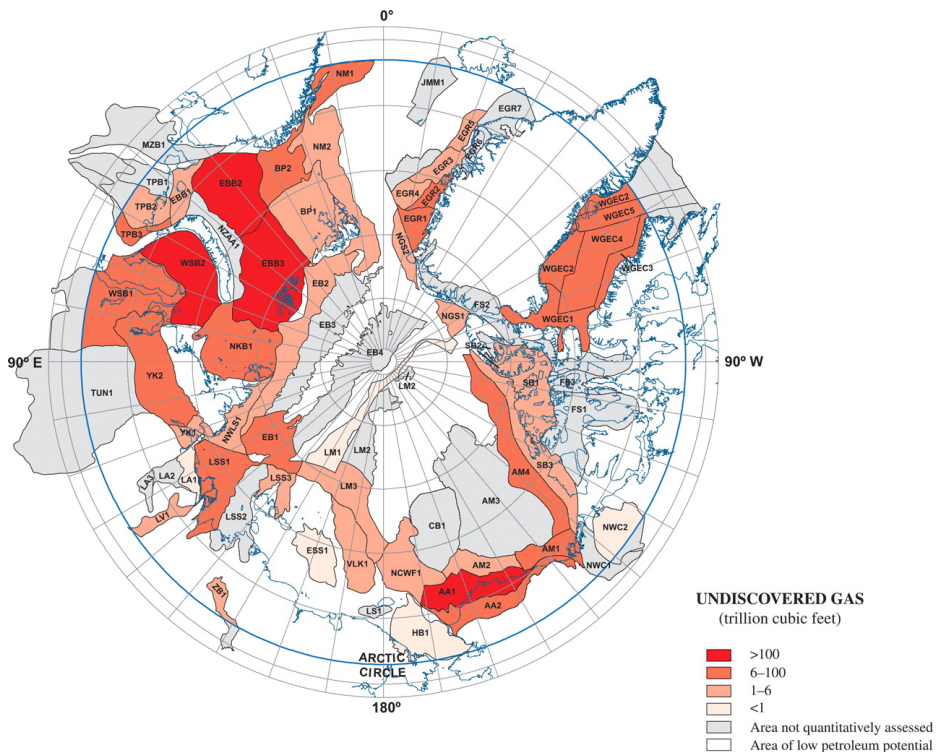

Figure B.4: Undiscovered gas reserves in the Arctic as assessed by USGS [46].

oil field Goliat is also under development, and it will utilize a circular FPSO. Electricity and communications will be provided from land through a subsea cable. In addition, some exploration activities are ongoing in the Norwegian sector. The west coast of Greenland is also assumed to be an area with large quantities of hydrocarbons. There are ongoing exploration activities, and oil and gas have been found. However, currently there is no production. In the Canadian Arctic archipelago, there is limited activity from the petroleum industry.

B.1.4 Research activities

Polar science and research is definitively not a new field, but with the threat of global warming it has grown in importance. Research in the Arctic is performed at permanent and temporary stations, research vessels and mobile expeditions. Temporary stations can be land based facilities or camps on the sea ice. Research vessels comes in all sizes up to the large Russian nuclear

powered ice breakers. In addition, drifting buoys are used extensively to gain an understanding of ocean currents and temperature.

Research vessels and temporary stations have similar communications requirements as the merchant shipping fleet. Both crew and scientists desire the ability to have contact with friends, family, home organization and colleagues, as well as access to infotainment. Access to communications services supporting the research activities and vessel operations is also necessary. Bandwidth requirements are usually not excessively high, and the performance of typical VSAT solutions will normally be adequate.

Mobile expeditions are typically small and primitively equipped. They may, for example, use small boats or canoes at sea and ski, dogsled or snow mobiles on ice and land. Expeditions of this type have limited communications requirements. Some form of contact with the rest of the world is necessary, but the need for a high capacity data link is normally not present. Voice and low rate data services are usually sufficient. However, regardless of the crew and expedition size the most important communications requirement is access to a reliable emergency service.

Research activities in the Arctic do not have any specific geographic limitations. Vessel based research is mostly done during summer time and in ice free areas, but ice breakers are also used for research far into the pack ice. Temporary research stations are from time to time placed on the pack ice, and they can drift along with the ice as long as it is safe. Mobile expeditions can be found everywhere. Locations and communications requirements of permanent research stations are discussed in section B.3.2.

B.1.5 Governmental activities

Maritime governmental activities in the Arctic are mostly handled by coast guards and similar more or less military based organizations. Along with rescue coordination centers, these organizations are important in Search and Rescue (SAR) operations. They also monitor the fishing industry, do customs control and are part of national oil spill contingency plans. These are just examples of governmental maritime responsibilities in the Arctic. Activities such as monitoring fisheries and shipping as well as taking part in SAR operations are crucial governmental responsibilities all around the globe. Because of the vulnerable environment and harsh climate in the Arctic, this is even more important here. Thus, coast guards and other governmental institutions focus on the areas where the fishing, shipping or petroleum industry are present.

Near ports, harbors and close to shore the vessels used for governmental activities are fairly small and only at sea for short periods at a time. Normally, these vessels will operate within the range of VHF stations and land based cellular network infrastructure. Thus, under normal conditions their communication needs should be satisfied. Larger vessels are used for operations far from land. These vessels have a large crew and can sustain themselves for several weeks. As a result, their communications requirements are similar to other types of vessels that are at sea for long periods at a time. Coast guard and similar institutions are also part of national defenses. Thus, they need access to military communications services and encrypted networks.

B.2 Aeronautical activities

Aviation authorities divide aeronautical activities into a large number of categories. Here, aircraft activities are divided into three general categories:

- Scheduled flights
- Non-scheduled flights
- General aviation

These category names are also used by aviation authorities, but then more narrowly defined. Military flights are a potential fourth category. However, due to large differences between civil and military operational requirements this category is not taken into account, but it is a large potential market.

B.2.1 Scheduled flights

Scheduled flights are aircraft movements between two or more airports as part of a regular service. Both airplanes and helicopters, transporting passengers, cargo or mail, can be included in this category. In the Arctic, there are two types of flights, cross polar and Arctic destination flights. Cross polar flights are large passenger and cargo planes crossing the Arctic on their way between Europe, North America and Asia. Arctic destination flights are aircrafts on a route with at least one destination in the Arctic. For many flights between Europe, Asia and North America, the shortest route is across the Arctic. Since the late fifties, airlines have taken advantage of this. After Russian aviation authorities allowed international airlines to transit Russian airspace in

the mid nineties, the number of cross polar flights have increased. In 2010, the maximum monthly count of cross polar flights was just below 1 000 [48].

Most of the communities in the Arctic are small with a corresponding small passenger base. Thus, Arctic destinational flights are usually less frequent and are conducted by smaller airplanes and helicopters. There are only a few exceptions. One example is Longyearbyen Airport at Svalbard with two scheduled flights per day operated by a medium sized passenger jet. The vast distances in the Arctic have made aircrafts the preferred transport for passengers and light cargo. Thus, almost all communities in the Arctic have access to a small airstrip. Location of settlements and communities are discussed in section B.3 about land based activities.

B.2.2 Non-scheduled flights

Non-scheduled flights are aircraft movements that are not part of a regular service. Examples are charter, taxi, special event and emergency flights. Surveillance and inspection flights are also part of this category. For a large number of communities without regular air service, charter flights are used for passenger and light cargo transport. Non-scheduled flights are carried out all across the Arctic, but normally centered around and between settlements, communities and installations.

B.2.3 General aviation

General aviation normally refers to small aircrafts operated by private owners on a non-commercial basis. Even though this category might involve a relative high number of small aircrafts, they have limited requirements for satellite communications. The low cost profile of aircrafts in this category results in a limited range and a small budget for retrofits. Also, they often operate without the direct involvement of aviation authorities.

B.2.4 Communications requirements

The most important communications requirement for aeronautical activities is access to ATM and Air Traffic Control (ATC) services. Communications between flight controllers on the ground and pilots on board aircrafts are today accomplished through ground based infrastructure. Specially allocated

frequencies in the VHF and HF bands are used for this purpose. Commercial narrowband communication services are offered in L band through Inmarsat satellites. A number of companies also supplies inflight broadband services. These services are realized through ground based infrastructure in the UHF band or geostationary satellites in the K_u band. In addition to airline operational data, these services is mainly used to offer passengers access to telephone and internet services while in flight.

Through the SESAR project, the European Union (EU) is working together with European aviation authorities to modernize the use of airspace. An important part of the project is how aircrafts communicate with air control centers. That part of SESAR runs under the auspices of ESA in the IRIS program. The aim of the IRIS program is to establish a satellite based air to ground communications system for ATM, providing digital data links across all European controlled airspace. A communication system for ATM services in the Arctic should be compatible with the future European ATM system. Thus, the system requirements of an Arctic ATM service will to a large extent be driven by requirements in the IRIS program.

B.3 Land based activities

Most of the Arctic consist of ocean. As a result, the land based activities in the Arctic are limited. Land based activities in the Arctic are mostly centered around small communities and installations. Arctic communities are usually settlements of indigenous people, research stations or a natural resource industry. The map in Figure B.5 shows the location of Arctic settlements. Whether the settlements can be accessed by air, is indicated by the color of the circles. This is not a complete overview of Arctic settlements. Only inhabited places above 70° North are shown, but not necessarily all. There exist communities north of the 70th parallel which is not shown on the map. Especially the Norwegian mainland and Russian territories are more inhabited than indicated in Figure B.5.

B.3.1 Local population

In the Arctic, there are a number of small communities. They range in size from only a few families and up to several thousand. The communications requirements of Arctic communities vary with size and the occupation of the

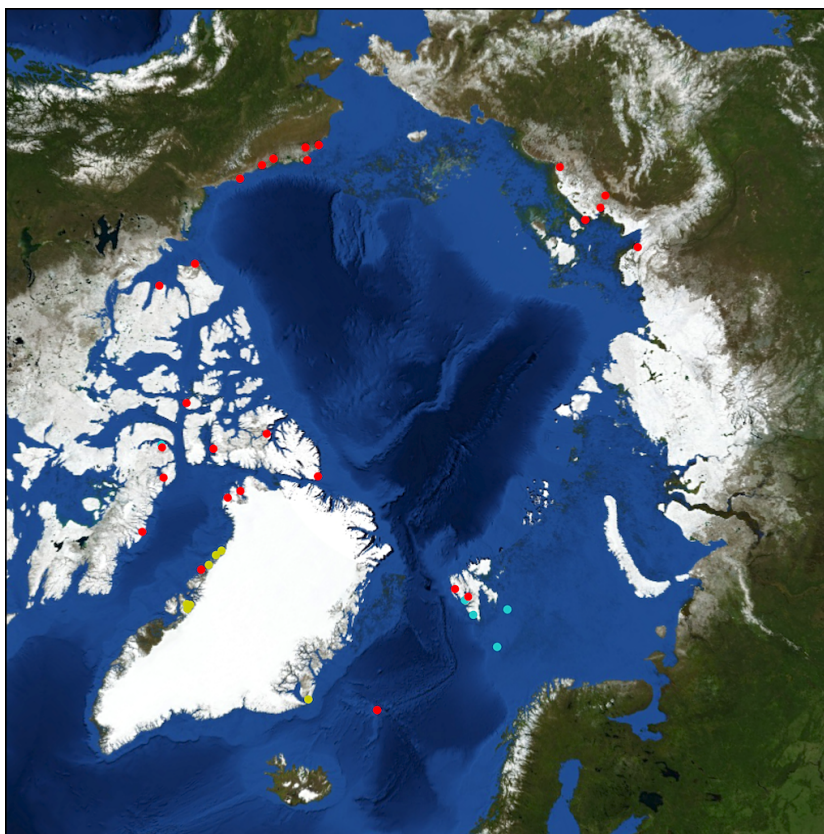

Figure B.5: Settlements north of the 70th parallel. Red circle denotes settlement with airfield, yellow circle is settlement with heliport serviced regularly, while cyan circle denotes settlement without airport. The map is not conclusive. Especially the Norwegian mainland and Russian territories are more inhabited than indicated here.

inhabitants. The smallest settlements usually consist mainly of indigenous people who survives largely through hunting and fishing. Many who live in these small communities have chosen to do so partly due to a desire to live like their ancestors. These people have very limited need for access to broadcasting services and internet applications. However, the possibility of access to such services might over time improve their standard of living and reduce the depopulation of small settlements.

Communities large enough to warrant support functions, such as schools, medical centers and government institutions, have higher communications requirements. Advances in telemedicine reduce the need for travel in order to get appropriate medical care, thus, saving lives. Use of distance learning

applications also allows children and youth stay longer in their communities while still have a broad choice in educational alternatives. These are only two examples of applications important for Arctic communities, which reliable broadband communications services can provide. Global connectivity and knowledge of current events are also important for the standard of living in the current society. Broadcasting services and internet access are, therefore, necessary requirements for future sustainable activities in the Arctic.

The archipelago of Svalbard makes up most of the landmass in the Norwegian part of the Arctic. Svalbard have no settlements of indigenous people, but the town of Longyearbyen with more than 2 000 inhabitants is a large community on an Arctic scale. With two daily flights to the Norwegian mainland, Longyearbyen functions as a gateway for tourism and adventure activities as well as polar research. The worlds largest downlink station for polar satellites, SvalSat, is located on a mountain close to the town. Until 2003, telecommunications with Svalbard went via satellite through Isfjord Radio at Cape Linné. Longyearbyen and other inhabited places were connected to Isfjord Radio with radio links. In 2003, an optical fiber cable between Longyearbyen and the Norwegian mainland was commissioned. Through the fiber cable, all fixed installations and settlements are connected with the rest of the world. The large scale of the satellite downlink operations of SvalSat became possible with the fiber cable.

On the west coast of Greenland, there are several towns and settlements as shown in Figure B.5. They are mostly inhabited by indigenous people. The main livelihood on Greenland is the fishing industry, but also mining activity and tourism are increasing in importance. Due to large distances, airplane or helicopter is preferred for transportation between towns and settlements on Greenland, but ships and ferries are also used. The Canadian Arctic Archipelago holds a number of communities. They consist mainly of indigenous people with hunting and fishing as their livelihood. Tourism as well as production of arts and crafts are important sources of income. Communities in proximity of natural resources such as minerals and hydrocarbons are also important for support of these industries. These Canadian towns and settlements also holds various governmental and administrative functions.

Alaska also has Arctic communities. Those that are north of the 70th parallel, all lies on the coast of the Beaufort Sea. Most of these settlements are there to support the oil industry on the North Slope. Barrow is the largest community with a population of almost 4 000. In addition to hunting, fishing and the oil industry, several state and federal agencies are important employers

in Barrow. Russia also has a local population in the Arctic. Only a few of those towns, cities and settlements are shown in Figure B.5. More information and increased knowledge are needed to understand the complete picture in the Russian part of Arctic.

B.3.2 Research stations

The communications needs of research stations are in many respect similar to those of small towns and settlements. Personnel at the stations require contact with the rest of the world through telephone, internet and email. This is for personal welfare and scientific experiments and measurements. The harsh climate and extreme remoteness of the majority of Arctic research stations also makes reliable emergency communications systems important. Solutions for telemedicine applications are also required as they are potentially life saving in cases of sudden illness and severe accidents. In some cases, scientific experiments may have special needs in terms of bandwidth and performance. However, the research community is usually good at adapting experiments to the available solutions.

In the Norwegian part of the Arctic, there are several research stations with permanent staffing. Most of them are situated on the Svalbard archipelago. The largest station is at Ny-Ålesund, north-west of Longyearbyen. It has a permanent staff of about 25. However, during the summertime scientists from all around the world travels to Ny-Ålesund and the population grows to more than 120. In Hornsund, in the southern part of Spitsbergen, there is a Polish research station staffed year round by 10 people. On the islands Hopen and Bear Island, there are meteorological stations operated by the NMI. These stations have a personnel of respectively four and nine. The island of Jan Mayen also has a manned station. This is operated by the Norwegian Defense and has some personnel from NMI who have responsibility for meteorological observations. The Norwegian Defense presence is mainly to maintain the navigation infrastructure of the LORAN-C transmitter and European Geostationary Navigation Overlay System (EGNOS) reference station.

On Ellesmere Island in the Canadian Arctic Archipelago, there are two research stations, Alert and Eureka. With Alert at 82.5° North and Eureka at almost 80° North, these are the two northernmost permanent communities in the world. Both stations are operated by Canadian Forces. Alert has a military signal intelligence radio receiving facility, and Eureka is important as a relay station for communications between Alert and geostationary satellites. In

In addition, there are meteorological stations as well as facilities for atmospheric observation and other scientific research projects. Alert has a personnel of about 60. Eureka is much smaller with a Canadian Forces contingent of eight people in addition to a few people handling the civilian facilities. Russia has a long history in Arctic research. However, information on the location and situation of research stations and facilities in the Russian part of Arctic is limited. Having a long tradition within science and technology, Russia is expected to be present, but to which extent is not known.

B.3.3 Natural resources

Natural resources are used here as a general term for resources that are extracted from the earth. Examples of facilities taking advantage of natural resources in the Arctic are mineral mines, coal mines and hydrocarbon production installations. Communities formed around such industries can be similar to regular Arctic settlements, but they are usually organized differently. These communities normally have few permanent residents. Work is based on a rotating shift routine with a few weeks on site followed by a few weeks off site. In the weeks off site, the workers are replaced by another rotation allowing them to go home to their families who live elsewhere. Heavy machinery plays an important role at facilities taking advantage of natural resources. Thus, in addition to communication requirements generated by the operations, communications systems for emergency situations and distress and safety is paramount. When life threatening accidents happen, effective and reliable telemedicine applications can save lives if conventional help is not available.

At Svalbard today, there are two coal mine communities at Barentsburg and Sveagruva. Barentsburg is a Russian mining town with a population of about 500, mainly Ukrainians. The coal production in Barentsburg has been declining over the last decade. Sveagruva is owned by the Norwegian company Store Norske, and there exists expansion plans. The workers at Sveagruva live in Longyearbyen and travel on a weekly basis to work at Sveagruva. In the Canadian Arctic Archipelago, the mining and petroleum industry has a limited presence. Previously, there was a lead-zinc mine at Nanisivik on Baffin Island, but it was closed down in 2002. The Canadian Navy plans to convert the site into a naval facility. During the 1970s and 1980s extensive oil and gas exploration was undertaken in the Canadian Arctic. A number of fields were discovered on Ellesmere Island, Ellef Ringnes Island, King Christian Island and Cameron Island, but large scale production were never started. Two of the gas fields found are among the largest in Canada. Production at these fields

will probably happen some time in the future when the market conditions have improved [49].

On the North Slope of Alaska the oil production is extensive. These fields have been in operation since the 1970s. The oil fields in Alaska are the most mature fields in the Arctic, but they are still evolving and will be in production for many years to come. The gas fields on the Yamal peninsula contains Russia's biggest reserves, and Gazprom is developing the Yamal project. Gas produced in this area is transported south in pipelines. Other parts of the Russian Arctic are also explored, but further studies are needed to get a complete picture. Indications on where there might be activities can be extracted from Figure B.3 and B.4.

B.4 Future development

In the future, the activity in the Arctic is expected to increase. Increasing temperatures are reducing the ice coverage, for at least a part of the year. This will open up new areas for the fishing industry as well as the petroleum industry. Future ice free NEP and NWP will result in increased maritime traffic as the shipping industry takes advantage of the shorter sailing routes. This increased activity will in turn require an increase in the governmental Arctic activity. The various governments must ensure that the increased activity follows the principles of sustainable development. That can only be done through a regulatory role supported by observation, monitoring and an active presence in the area. Safety, both for man and nature, is also a governmental responsibility.

Appendix C

Available solutions today and near future

A HEO satellite based alternative is not the only solution for communications coverage of the Arctic. In the following sections, current and planned alternative solutions and available systems are discussed. The candidates are discussed and analyzed with regard to their ability to meet Arctic communications user requirements and needs. Systems and solutions discussed are terrestrial systems, GEO satellite systems, inclined geosynchronous satellites, LEO satellite systems and HEO satellite systems.

C.1 Terrestrial systems

The settlements and communities in the Arctic are small, and they are far from each other. This makes terrestrial infrastructure expensive and not cost efficient. Thus, there are very little terrestrial communications infrastructure in the Arctic. Cellular coverage is limited to settlements and their immediate surroundings, and often uses satellites to connect with the world. Fiber optical cable is rarely available, except when close to oil or gas pipelines and in Longyearbyen at Svalbard. MF, HF and VHF are three frequency bands extensively used for radio communications in both the maritime and aeronautical sector. MF and HF are the frequency bands from 300 kHz to 3 000 kHz and 3 MHz to 30 MHz. VHF is the highest and widest of these frequency bands from 30 MHz to 300 MHz.

The two lowest bands are primarily used for communications over long distances. Due to special effects in the atmosphere and ionosphere at such low frequencies, a range of more than 3 000 km is not unusual. However, the range fluctuates depending on a number of parameters such as humidity, temperature, time of day and solar activity. The vast potential range also makes MF and HF systems highly exposed to interference. This limits the spectrum efficiency of these already narrow frequency bands significantly. Maritime vessels use MF and HF mainly for emergency communications as well as weather and navigation information broadcasted by radio stations. Aeronautical use of MF and HF is primarily voice communications for ATC. There are Arctic radio stations in Norway, Canada, Greenland and Russia handling the communications and information broadcasts.

The higher frequency of the VHF band reduces the operational range. Depending on the height of transmitting and receiving antennas typical maritime VHF range is from 40 km to 120 km. Maritime VHF radio is primarily used for emergency communications and information broadcasts. Many coastal radio stations offer narrow band data transfer services within their coverage area. However, when out of range of coastal radio stations, communications are limited to other vessels in the area. Norway, Canada, Greenland and Russia all operate coastal VHF stations in the Arctic. Aeronautical VHF is the preferred medium for ATC voice communications.

HF and VHF constitute crucial parts of GMDSS and air traffic safety and are used for this purpose in the Arctic today. However, HF communications are not viewed as reliable. It is concluded that terrestrial communications systems in the Arctic are not able to meet the user requirements, neither in terms of coverage or service capabilities.

C.2 GEO satellite systems

Satellites in circular orbits in the equator plane and a period equal to the sidereal day will stay above the same point on earth. This orbit is referred to as the geostationary earth orbit, abbreviated to GEO. GEO satellites are frequently used for communications as one such satellite can cover up to 44.1% of the earth surface. An important factor for the success of the GEO satellite industry is the possibility to use fixed terminal antennas with high directivity on the ground as the satellites are stationary. One example is satellite broadcasting where users can install an antenna dish themselves

and receive TV channels from the satellite of their desire. This simplicity has made broadcasting services the most profitable within the space industry.

As the earth is spherical, a GEO satellite is not visible at very high latitudes. A satellite positioned on the same longitude as a user will fall below the horizon as the user moves north of 81.3° . There will not always be a usable GEO satellite due south. Thus, the practical limit of GEO visibility can be several degrees below this theoretical limit. For communications systems, the situation is even worse. At low elevation angles, radio signals experience high attenuation due to the long path through the atmosphere. The long signal path also leads to increased rain attenuation. In addition, scintillation effects occur at very low elevation angles. This causes fast and large fluctuations in received signal strength.

Prior to installation of the fiber optical cable, satellite communications were the only means of communications between Longyearbyen at Svalbard and the Norwegian mainland. This was achieved through the employment of large stationary antennas from Isfjord Radio, located at Cape Linné on approximately 78° North. Eureka at almost 80° North in the Canadian Arctic archipelago still uses GEO satellites as their primary means of communications. Thus, stable communications with GEO satellites are possible from fixed sites close to the theoretical visibility limit, but it requires complex and expensive solutions. Mobile and maritime users are in a different situation. They have limited available space to accommodate antennas, and small antennas result in reduced antenna gain. Additionally, they use steerable antennas to track satellites which introduces losses due to pointing errors. Thus, mobile and maritime systems are not stable and reliable as far north as complex fixed installations. Maritime VSAT services are regarded as unstable above 72° to 75° North, and Inmarsat only guarantee their service up to 76° North [5, 6].

It can be concluded that GEO satellites are not able to provide the Arctic with reliable and continuous communications services. Fixed users with specially designed solutions can utilize geostationary satellites up to about 80° northern latitude. Mobile and maritime users will experience unstable performance above 72° to 75° North.

C.3 Inclined geosynchronous satellites

A satellite in a circular inclined orbit with a period equal to a sidereal day is an inclined geosynchronous satellite. This orbit type is very similar to GEO, but

the orbital plane is inclined. In fact, a GEO satellite without inclination control quickly becomes an inclined geosynchronous satellite. Most GEO satellites end their operational life as inclined satellites. The ground track of these satellites forms a figure eight, with the intersection point at the equator and northern point at a latitude equal to the inclination. With an inclination larger than 8.7° , such a satellite will be visible from the North Pole. However, only for a brief period each day. An inclined geosynchronous satellite will spend a half of the orbit above the southern hemisphere. Thus, it is necessary to have at least three satellites with an inclination of at least 20° in order to realize continuous coverage of the North Pole. Full Arctic coverage will require even higher inclination, or another set of satellites on the opposite side of the world. Currently, there are no operational satellites with the required high inclination.

In sum, this makes inclined geosynchronous satellites unsuitable for continuous communications coverage of the Arctic. However, inclined geosynchronous satellites may be a usable solution for some users without continuous availability requirements. By employing old GEO satellites, such a solution can be put together fairly quickly and function until a complete system with continuous coverage is realized.

C.4 LEO satellite systems

A LEO is normally defined as an orbit between the atmosphere and the inner Van Allen radiation belt. Because of rapid decay, caused by atmospheric drag, satellites are seldom put into orbit with altitude less than 200 km to 300 km. The inner Van Allen radiation belt starts at an altitude of around 1 000 km. A satellite in an orbit with an altitude between 200 km to 1 000 km is a LEO satellite. This is sometimes stretched up to 2 000 km. In the 1990s, there were massive interest in using LEO constellations for mobile communications. At the time, the mobile communications market was growing, but there was no standards for terrestrial systems. Many system solutions existed, but roaming between operators in different countries was often not possible. A satellite system with global coverage would solve this, and it was believed that costumers, especially the traveling businessman, would be willing to pay a premium for this global coverage.

LEO was the preferred choice of orbit for most of the systems being discussed. The low altitude minimized the signal delay, and it was assumed that the satellites could be designed small and at a low cost. This assumption was

quickly proven wrong as the system design become more and more complex. At the same time, terrestrial systems were digitalized and harmonized, and Global System for Mobile Communications (GSM) became a standard for terrestrial systems. This stopped most of the LEO constellations from being realized, but three were launched and are still operational today. These are the Orbcomm, Globalstar and Iridium constellations. These systems and their capacity in the Arctic are discussed in the next sections.

C.4.1 Orbcomm

The Orbcomm constellation consists of 27 satellites in almost circular orbits with an altitude from 700 km to 900 km. Except for one satellite in a polar orbit, all the satellites have an inclination of about 45°. This constellation provides global coverage, including the Arctic and high latitude areas. However, the coverage is not continuous. The original constellation counted 35 satellites, but eight have been decommissioned due to satellite failure. In June 2008, six replacement satellites were launched. Unfortunately, these six satellites experienced issues with the attitude control system and its power system. As a result, they have been declared as a loss by Orbcomm.

Orbcomm provides Machine to Machine (M2M) applications at low data rates in the 137 MHz to 150 MHz frequency range. The services are mostly of the store and forward type. Messages and data packets are sent from users to a passing satellite. These messages are stored onboard the satellite until it passes over one of the central ground stations, and is transmitted down. The same process applies for information sent in the other direction. Thus, Orbcomm is not a real time communications system, but it functions well for small information volumes from six bytes up to a few kilobytes. Short Messaging Service (SMS) and email are examples of applications suitable for the Orbcomm system. Asset tracking and control is the most popular Orbcomm application. Orbcomm terminals with Global Positioning System (GPS) are installed on ships, trucks, containers, heavy machinery and so forth. The terminals regularly send information back to the owners' head quarters or control centers. This allows shipping and freight industry as well as others up to date information about position, progress and health of remote assets.

Orbcomm is in the process of renewing the constellation. 18 satellites manufactured by Sierra Nevada Corporation and Argon ST will be launched by SpaceX between 2012 and 2015. Falcon 9 rockets will be used to put the second generation Orbcomm satellites into 700 km orbits with 52° inclination.

These new satellites will improve coverage and capacity of the constellation, but the system concept will be the same. In the Arctic, the Orbcomm constellation can provide some Low Data Rate (LDR) services, such as M2M applications. However, the store and forward operations concept combined with non-continuous Arctic coverage, limit this to applications without real time demands. Thus, Orbcomm alone does not satisfy all the Arctic user requirements, only some of the LDR service requirements.

C.4.2 Globalstar

Globalstar is a satellite system consisting of 48 satellites in LEO. The constellation consists of eight orbital planes with an inclination of 52°, and altitude of approximately 1 400 km. L and S band is used to support voice and narrowband data services to handheld and small terminals. The satellites in the original constellation were launched between 1998 and 2000. They were designed for a lifetime of seven to eight years. Some of these satellites have experienced failures. As a result, Globalstar has for a long period struggled to provide users with a stable communications service, but the constellation is in the process of being rejuvenated. A total of 24 second generation satellites is scheduled for launch by the end of 2012. Together with eight first generation satellites launched in 2007 they will form a 32 satellite constellation.

The Globalstar satellites are bent pipe configured, and lack inter satellite links. To connect a call, a satellite has to be visible for both the user and a ground station gateway. Thus, an extensive ground station network is required. 24 ground stations are spread across the world, but that is not enough for global coverage. Especially the oceanic coverage is poor. The Arctic is not covered by Globalstar. There are no ground station gateways in the Arctic. This is of less concern as the Globalstar satellites never are visible above 86.9° North. Thus, continuous and stable coverage can not be expected north of 80° even with an Arctic ground station gateway. With the current situation, stable coverage is limited to about 70° northern latitude. The Globalstar system does not meet any Arctic user requirements.

C.4.3 Iridium

With 66 active satellites in polar orbits, Iridium is the largest and most complex system of the three LEO systems. The satellites are divided into six orbital planes with eleven satellites in each and have an orbital altitude of around

780 km. User terminals utilize the L band to communicate with the satellites while the K_a band is used for feeder links. Communications between satellites has been made possible with inter-satellite links. The inter-satellite links allow calls and data transmissions to be routed through several satellites and down to a gateway. This capability makes Iridium able to provide truly global and continuous coverage, including the Arctic and Antarctic. Iridium offers voice and narrowband data services. Originally Iridium was designed primarily as a voice service, but a data service was added early. A data bit rates of 2.4 kbit/s is offered by the regular service. Channels can be bundled up to 128 kbit/s , but service performance depend on satellite capacity and availability at any given time.

The original constellation with six spare satellites was launched in 1997 and 1998. Additional spare satellites were launched in 2002. These first generation Iridium satellites were designed with a lifetime of 5 to 8 years. Several of the original satellites have been replaced by spare satellites. Most of them are still in operation, but they are way past their design life. It has been estimated that the satellites currently in the constellation will be able to provide the current service level until about 2015. Thus, a new generation of satellites has been an important issue for Iridium in recent years. In June 2010 Iridium awarded a contract for the development and production of the new generation of satellites to Thales Alenia Space. The first launch is planned for 2015. This new generation of satellites, labeled Iridium NEXT, will provide increased performance, but it is currently unclear to which extent. Nevertheless, physical limitations, such as spectrum availability, mean that Iridium will not be able to provide services at the same performance level as GEO satellites.

As the only communications system with truly continuous global coverage, Iridium provides services to the Arctic. Voice and narrowband data services are available in the Arctic today, and the new Iridium NEXT satellites will secure this support also for the future. LDR and low performance broadband services can for many applications also be supported by Iridium. Power and spectrum limitations makes Iridium unable to support high performance broadband solutions. The cellular structure of the Iridium system makes it unsuitable for broadcasting applications.

C.5 HEO satellite systems

A majority of space based applications are best served by satellites in circular orbits, but elliptical orbits have interesting properties that might be useful for

some solutions. Especially satellites in HEO are of interest for Arctic coverage. Satellites have been launched into HEO orbits since the mid sixties. Russia and its predecessor the Soviet Union used a series of satellites in 12 h orbits to provide communications and broadcasting services. The satellite series was given the name Molniya, which in turn became the name for a 12 h critically inclined HEO orbit. Russia still operates satellites in Molniya orbit, but they are military and available information about the capabilities is limited. The new Meridian system has at the moment three operational satellites, launched in December 2006, November 2010 and May 2011. Meridian is designed for communications to Russian military users, both maritime and aeronautical, in the Arctic as well as to ground stations in Siberia and the Russian Far East. It has been indicated that it operates in the L and C bands. Being a military system, Meridian services are unavailable to commercial users.

The 24 h version of a critically inclined HEO orbit is known as a Tundra orbit. Tundra is Russian for thunder, complementing Molniya which means lightning. Currently, the American company Sirius Satellite Radio is the only user of Tundra orbits. They use three satellites in Tundra orbit, and one geostationary satellite to broadcast audio content to USA and Canada. Only one of the Tundra satellites is active at any given time. Sirius Satellite Radio chose the Tundra orbit for their broadcast service because it provides higher elevation angles for users in USA. Higher elevation angle gives improved reception and availability in rough terrain and urban canyons. The audio content is broadcasted in the S band with coverage of the continental United States, Central America and Canada up to about 65° North. No Arctic communication requirements can be met by Sirius Satellite Radio services.

C.5.1 Planned systems

There are ongoing projects that intend to establish HEO systems providing communications coverage of the Arctic. Most notably on the international stage has been the Russian Arktika and PolarStar projects and the Canadian Polar Communications and Weather (PCW) mission.

Arktika

The initial concept of the Russian Arktika project was first presented in 2007. It was primarily an earth observation system consisting of four satellites in Molniya orbits. The main focus was on meteorological applications. Since

then, the system seems to have gone through several transformations. Most notably a communications component has been added. Two communications satellites are intended to support broadcasting services, backhaul communications and mobile satellite services. Coverage of northern Russia and other Arctic countries has been indicated in the L, C, K_u and K_a bands. Press releases issued in 2010 indicated launch of the Arktika satellite system in 2014. How this has progressed since is unclear, and it is unknown how committed the Russian space sector is to the project. If the system is realized as described, it will provide necessary services to the Arctic. The ability of the Arktika system to meet user requirements in terms of services and capacity is uncertain.

PolarStar

The Russian company Gazprom Space Systems is developing the PolarStar system. Using three or four satellites in Tundra or Molniya orbits PolarStar is intended to provide high speed internet access to Russian territories and the Arctic. Gazprom Space Systems plan to use the K_a band and provide connection speeds up to $10^{\text{Mbit/s}}$. Operational capabilities from 2016 has been indicated. Information about PolarStar is very scarce as only a brief system description has been released. The progress of the PolarStar system is unknown, both in terms of technological and financial aspects. Uncertainties in system performance and timeframe make it difficult to assess the effect PolarStar can have on communications in the Arctic. Coverage is also limited to Russian territories.

Polar Communication and Weather mission

Various branches of the Canadian government, spearheaded by the Canadian Space Agency (CSA), have been working with the PCW project since 2007/2008. As the name indicates, it is a satellite system intended to provide communications and meteorological observations in the Arctic. Initial focus was on Canadian requirements, but at the end of 2009 they began to open up to the international community, primarily on the meteorology and earth observation side.

The meteorological coverage requirement for PCW includes the whole Arctic and beyond, down to 50° North. However, the communications coverage requirements are limited to the Canadian area of interest; more precisely the sector of the Arctic from 70° North to the North Pole and from 40° to 180° west-

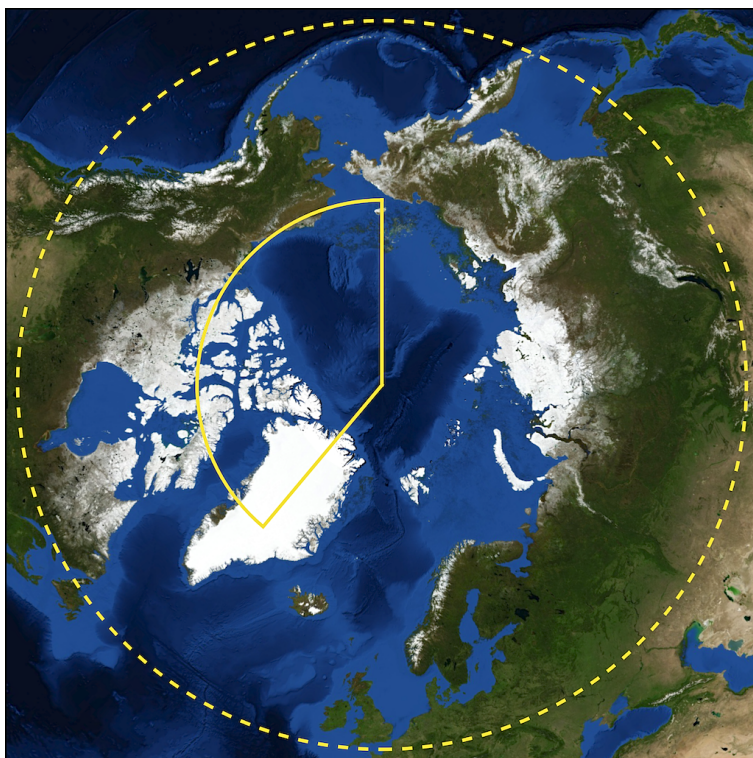

Figure C.1: The coverage requirements of PCW. The meteorological requirement is indicated by the yellow dotted circle, while the communications requirement is drawn in solid yellow.

ern longitude. These coverage requirements are shown in Figure C.1. Service requirements are focused towards fixed installations providing telecommunications to remote settlements and aeronautical support, primarily for Unmanned Aerial Systems (UAS). Civilian communications services are to be offered in K_a band while Canadian military also require X and UHF coverage.

Initially, the plan for PCW was a constellation of two satellites in Molniya orbit. After further studies CSA now believes alternatives using satellites in 16 h and 24 h orbits also are able to meet the user requirements. The intention is to approach the project as a Private Public Partnership (PPP), and decide on a system solution that meet the necessary user requirements. At the current schedule CSA believes the system can be launched in 2018. The communications coverage intended for PCW at present will not meet all Arctic communication user requirements. Through the PPP, the private interests might expand on the intended coverage improving the business case of the

project and offer necessary services to the whole Arctic region. ESA has shown some interest in the possibility of a European communications payload on the PCW satellites. PCW is a promising project, but there are a number of uncertainties tied to it, such as coverage, services to be provided and time schedule. This makes it difficult to predict how the PCW mission can meet the future communications requirements in the Arctic.

C.6 Summary and conclusions

There are no systems currently operational or planned for the near future that are able to satisfy all Arctic communication user requirements. New solutions are needed for sustainable growth and development of the Arctic and high latitude regions. HF and VHF radio systems are used in the Arctic today for emergency communications as well as voice and very narrowband data services. However, the range of VHF radio services are limited to line of sight, and HF radio communications have very low capacity and are unreliable.

GEO satellites are not visible above 81.3° North, and low elevation angles result in unstable service already at 72° to 75° North. Satellites in GEO are, therefore, not able to support Arctic communications. Old GEO satellites in inclined orbit may be used for communications in southern parts of the Arctic, but the coverage will not be continuous. Inclined GEO satellites are only interesting as a temporary solution for users with special needs and requirements that do not have other alternatives.

When it comes to LEO satellite systems, both Iridium and Orbcomm have coverage of the Arctic. Orbcomm only supports low rate store and forward services, but Iridium provides voice and narrowband data communications. It is likely that Iridium can satisfy the Arctic communications user requirements in terms of voice and narrowband services. The new generation of satellites, Iridium NEXT, can be assumed to ensure the necessary services and capacity.

The use of satellites in HEO is assumed to be the preferred solution for continuous and reliable communications coverage of the Arctic. There is no commercially available system providing communications to the Arctic today. Three systems are under development, the Canadian PCW mission and the Russian Arktika and PolarStar projects, but there are uncertainties regarding among other things coverage, services and time schedule for these systems.

Appendix D

Frequency regulatory issues

The frequency spectrum is a limited resource. As a result rules and regulations on how the frequency spectrum can be used have been agreed globally. Frequency allocation and assignment are coordinated through the International Telecommunication Union (ITU) and national governments. The ITU is a specialized agency of the United Nations (UN) with a membership of 193 countries. One of the main areas of activity for ITU is the international management of the radio frequency spectrum and satellite orbits according to the regulations adopted by the WRC. These regulations stipulate how different frequency bands can be utilized, both in terms of service types and usage parameters such as power and flux densities. ITU issues these as the Radio Regulations and updates them after each WRC. The following considerations are based on the version from 2008 [34].

Frequencies are allocated to a wide range of applications. Services such as fixed communications, mobile communications, radio navigation, broadcasting, fixed satellite communications, mobile satellite communications, satellite broadcasting are only a few examples. Parts of the frequency spectrum are also allocated for passive use. Examples of passive use include radioastronomy, earth observations and even search for extra terrestrial intelligence.

Spectrum are allocated for satellite communications services on a primary basis in several frequency bands. The most important allocations for satellite communications are for FSS, Mobile Satellite Service (MSS) and BSS. Additionally there are frequency bands allocated for communications services such as amateur satellite radio, earth observation and meteorological satellite data download and satellite navigation. Service requirements in the Arctic can only

Table D.1: Summary of frequency allocations for satellite communications.

Band	Downlink [GHz]	Uplink [GHz]	Service	Remark
L	1.518 - 1.559	1.610 - 1.675	MSS	No bandwidth available
S	2.170 - 2.200	1.980 - 2.010	MSS	No bandwidth available
C	3.400 - 4.200	5.850 - 7.075	FSS	Require large antennas
X	7.250 - 7.750	7.900 - 8.400	FSS	For governmental use
K _u	10.700 - 11.700	12.750 - 13.250	FSS/BSS	Dominated by BSS and moderate rain fade
	11.700 - 12.750	13.750 - 14.500		
K _a	18.100 - 21.200	27.500 - 31.000	FSS	Large rain fade
Q/V	37.500 - 42.500	47.200 - 51.400	FSS/BSS	Currently not used

be met using frequency bands allocated for FSS, MSS or BSS. There are some very narrowband MSS allocations in the area around 140 MHz, but the main allocations to these communications services are above 1 GHz. These allocations are in seven frequency bands, namely the L, S, C, X, K_u, K_a and Q/V bands, and are summarized in Table D.1.

In the Radio Regulations, the world is divided into three regions. Region 1 contains Africa, Europe, the Middle East and Russia. North and South America make up Region 2 together with Greenland and northern Pacific while Region 3 is South Asia, Southern Pacific and Oceania. A map illustrating the ITU regions is shown in Figure D.1. The coverage area of an Arctic system will overlap with all three regions. Frequencies are to some extent allocated differently in the three regions. Thus, only global allocations valid in all three regions are considered relevant and listed in Table D.1.

The L band is important for mobile satellite communications with providers such as Inmarsat, Iridium, Globalstar and Thuraya. They provide communications to maritime, aeronautical and land based users with low gain terminal antennas. Services provided by Inmarsat have for many years been a crucial part of GMDSS. Similar services as those in the L band are planned and to some extent implemented also in the S band. Frequencies in the L and S bands listed in Table D.1 are all assigned to various providers such as those mentioned. Inmarsat, Thuraya and Solaris Mobile use GEO satellites to provide their services while Iridium and Globalstar use constellations of LEO satellites. Common to them all are low gain user terminals which makes frequency reuse by another system almost impossible. In addition to the S band allocations shown in Table D.1, there is an BSS allocation. However, it is only 15 MHz, and it is intended for audio and video services to mobile and handheld units.

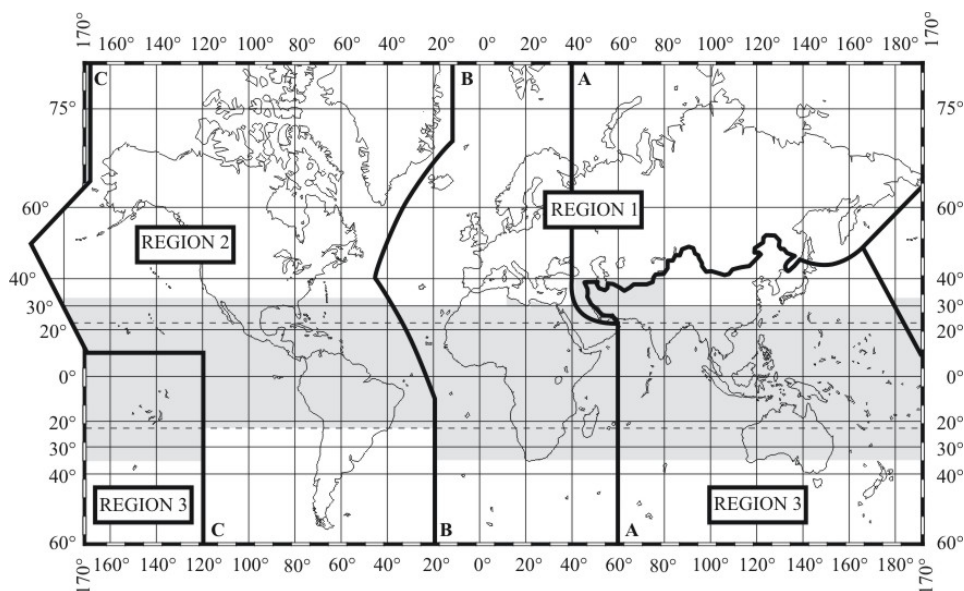

Figure D.1: The world divided into regions as defined by ITU and the Radio Regulations. The shaded area indicate the Tropical Zone [34].

The limited bandwidth in L and S band force the conclusion that they are not the appropriate frequency bands for satellite broadband applications, including an Arctic communications system supporting broadband applications.

The frequencies allocated for satellite communications in C band is for fixed services. The Radio Regulations state that earth stations onboard ships are allowed to receive between 3.7 GHz and 4.2 GHz, and transmit between 5.925 GHz and 6.425 GHz. This is highly interesting for an Arctic communications system since a large part of the coverage area is ocean. However, a maritime C band user communicating with a GEO satellite, must operate within some technical boundaries. The boundaries have been established to ensure minimal interference to other GEO satellites and terrestrial systems. One of those limitations is a minimum antenna diameter of 2.4 m. This is too large for many types of vessels. In a HEO based satellite system, the C band antennas can be smaller, but that will eliminate the possibility for compatibility between the HEO system and other GEO systems. Compatibility with GEO systems is assumed to be important for access to the number of users needed for a viable business case.

In the X band, 500 MHz in each direction has been allocated to FSS. However, those frequencies are reserved for military and governmental use only. It

is logical to assume that military forces and activities in Arctic countries are interested in X band coverage of the Arctic. That will allow support of their activities with the same equipment as elsewhere. However, military communications requirements have not been taken into account in this study. Thus, the X band is not a frequency alternative for the system in question here.

The K_u band has since the mid nineties been the preferred band for direct to home satellite TV broadcasting. As broadcasting is the single most profitable application of space to date, use of the K_u band is dominated by BSS. The cost of access to services in the K_u band is, therefore, heavily influenced by what revenue spectrum can generate if used for broadcasting. However, the frequency band from 10.7 GHz to 11.7 GHz is allocated for FSS applications in the space to earth direction, and the frequency bands from 12.75 GHz to 13.25 GHz and 13.75 GHz to 14.50 GHz for FSS in the earth to space direction. There are also FSS allocations in the K_u band from 14.40 GHz to 14.80 GHz and from 17.30 GHz to 18.10 GHz, but those are reserved for feeder links to BSS and in Region 2 only for GEO satellites.

Currently the K_u band is used extensively for data communications for both maritime, aeronautical and land based users. There are provisions in the Radio Regulations allowing the use of frequencies from 10.70 GHz to 12.75 GHz and from 14.00 GHz to 14.50 GHz by ESV. These provisions for maritime user terminals are highly interesting for an Arctic communications system. However, as in the C band there are technical limitations imposed on such terminals. The minimum antenna diameter of a maritime user terminal is 1.2 m. Maritime K_u band antenna size down to 0.6 m is allowed, but such terminals must meet the same interference requirements as terminals with 1.2 m antennas. The smaller antennas possible in the K_u band has led many maritime users to choose the K_u band solutions in favor of the C band alternatives.

With the K_u band becoming more and more congested, and available capacity scarce, the satellite communications community has moved some of the attention towards the K_a band. The K_a band represents the next step for increased capacity, and several operators have launched or are planning to deploy K_a band systems. In North America ViaSat-1 became operational in early 2012, while most of Europe have been able to take advantage of services from of KA-SAT and HYLAS since 2011. Of the K_a band systems under development, it is natural to mention Inmarsat's Global Xpress which will have global coverage and Telenor Satellite Broadcasting's Thor 7 with a focus on the maritime communications market in Europe and the Middle East.

The upper 1 GHz of the K_a band in both downlink and uplink allocations are

reserved for military and governmental use only. In the lower portions of the K_a band uplink allocations, there are provisions for feeder links to BSS, but not for exclusive use. Thus, there should be more than 1 GHz of bandwidth available in the K_a band for regular FSS use. These frequencies should also be easier to coordinate than frequencies in the K_u band because the number of K_a band systems is still somewhat limited. One issue that raises questions regarding the suitability of the K_a band for satellite communications, is the impact rain has on the radio link. Rain fades are more severe in the K_a band than at lower frequencies, but rain attenuation is addressed in section 6.3.2.

The Q/V band is the last satellite communications allocations considered here. There are also allocations in higher frequency bands, but currently it is assumed unrealistic that those bands will see widespread commercial use in the coming decades. In the Q/V band, there are large bandwidths available as the summary in Table D.1 indicates. The top 2 GHz of the downlink band have FSS and BSS co-allocated, and parts of the uplink band are reserved for BSS feeder links. In addition to the allocations indicated in Table D.1, there is allocated a band for FSS uplink from 42.5 GHz to 43.5 GHz and a MSS allocation from 43.5 GHz to 47.0 GHz. Part of the MSS allocation is for military and government use only.

There are currently no commercial operations in Q/V band. Long term propagation studies are being planned. Inmarsat's Alphasat will fly a Q/V band payload developed by ESA and designed for such studies. The lack of commercial use of Q/V band makes it less interesting than other alternatives. It removes the possibility for compatibility with GEO systems, which can open up for users to roam between the Arctic communications system and GEO systems. With limited long term propagation data available, it is difficult to assess the availability a Q/V band based communications system can provide. That have an impact on the reliability that can be expected of a communications link.

Even though a frequency band is allocated for satellite communications on a primary basis, there can be limitations on the use of the band. Mostly this is because the frequency band is allocated to other services on a primary basis as well, either globally, regionally or in one or more countries. This is the case in all the frequency bands allocated to FSS. A primary allocation to terrestrial fixed services at the same frequencies as the FSS allocation results in limitations on frequency use.

ITU have established limits on signal power and received power flux density on the ground. This is to ensure that satellite services do not interfere with

terrestrial fixed services. These limitations are defined in the Radio Regulations and are dependent on the elevation angle towards the satellite. At low elevation angles, the allowed power flux density is low to ensure minimum interference into terrestrial microwave links [34]. The levels vary between the frequency bands, but it is not assumed to have any significant impact in the choice of frequency. However, it must be taken into account in the link budget design.

The Radio Regulations stipulates that the bands listed in Table D.1 can be used by non-GEO systems on a non-interfering basis to GEO systems. Non-interfering basis means that they can operate as long as they do not create unacceptable interference to satellites in GEO. Thus, the Radio Regulations offer special protection to GEO systems in terms of interference from non-GEO systems. Non-GEO systems, whether they are in LEO, MEO or HEO, can not claim protection from GEO satellite networks as long as they operate in accordance with the Radio Regulations.

To ensure the non-GEO networks do not create interference in GEO networks maximum power flux density levels in both uplink and downlink are defined. Reference antennas to be used in evaluation of the possibility for interference are also defined by the Radio Regulations [34]. These interference levels are defined for the C, K_u and K_a bands and varies between the frequency bands. The K_a band has overall the most relaxed interference levels, but because of the large angular difference between the operational HEO satellites and GEO this should not be difficult to accommodate for any of the frequency alternatives. It is necessary to consider interference issues in the communications link design process.