

Reduction of speckle contrast in laser based HDTV projection displays

Anders Lifjeld

Master of Science in Electronics
Submission date: July 2007
Supervisor: Astrid Aksnes, IET

Problem Description

The main goals are to build a setup to characterize the speckle effect in laser based display applications and perform practical investigations to correlate the measured speckle contrast with perceived image quality. It is necessary to identify important physical parameters that influence speckle phenomena and identify possible quantitative measurements to characterize image quality (e.g. speckle contrast, contrast, sharpness, resolution). Methods to perform measurements will be analyzed and the setup will be implemented. The measurement setup will be based on a B/W digital video camera with imaging optics matched to the detector geometry.

A simple theoretical model will be sought developed to analyze how the different parameters affect the perceived image quality.

Speckle contrast and different methods to reduce speckle contrast will be studied and simple theory compared to the measurements. Speckle contrast and transmission will be measured in different configurations in the setup for e.g. an expanded laser beam that illuminates:

1. a screen
2. a vibrating screen (the frequency will be optimized to reduce the speckle contrast)
3. a stationary diffusor will be placed in front of the stationary screen
4. a diffusor will be modulated using different methods (vibration, rotation), the screen is stationary
5. two diffusors, one stationary and one that is modulated, the screen is stationary
6. same as 5) but the screen is modulated
7. a Hadamard matrix (if possible) placed in the beampath in front of a stationary screen

If time allows, Ignis Display will build a simple RGB laser projector such that measurements can be performed on a still image and later a video image. The goal is to correlate the measured speckle contrast with perceived image quality, and find a suitable limit for the speckle contrast level which is acceptable for HDTV applications.

It is desirable to design specific solutions to reduce speckle contrast in display systems based on Ignis' line scan technology, and test out the most promising concepts.

Assignment given: 24. January 2007

Supervisor: Astrid Aksnes, IET

Contents

- 1. Introduction..... 1**
- 2. Theory.....2**
 - 2.1 What is speckle..... 2
 - 2.2 Speckle reduction methods in the near field..... 2
 - 2.3 Objective and Subjective Speckle..... 3
- 3. Choices made in this setup.....4**
 - 3.1 The employed speckle reduction method..... 5
 - 3.2 Expectations to the results from the setup..... 5
- 4. Practical results..... 7**
 - 4.1 The 10 sets of tests..... 7
 - 4.2 The displacement of the modulator..... 15
 - 4.3 Calculation of the flying middle of the beam curvature..... 18
 - 4.4 Measured Speckle size..... 21
- 5. Discussion..... 24**
- 6. Conclusion..... 26**
- 7. References..... 27**
- 8. Appendix..... 29**
 - 8.1 Matlab Code..... 29
 - 8.2 Data sheet..... 33

1. Introduction

In the consumer display market there are many different technologies with many different factors which is better in some technologies than others. For some years laser light has been of interest to the display market manufacturers, because the light source can provide higher intensity light in projection displays, and it is also easy to make pictures with richer colored light providing light of frequencies not reachable for the conventional light sources. This will give a picture on a screen which can be enjoyed also at large distances and with the same time providing with light circuitry capable of giving a very high frame rate and refresh rate. With this feature a side effects are very apparent when connecting the display lasers instead of a conventional light source without doing anything else. The light from the laser source is very coherent, meaning that the light waves all inhabits the same phase and frequency and the observer will then detect effects from these waves having different wave path lengths interfering as discrete waves in the human retina and camera detector. This effect need to be taken in account and dealt with before releasing any display devices taking advantage from the intense laser light.

2. Theory

2.1 What is speckle

Speckle arise when coherent light is transmitted or reflected by a surface or a transparent film, and it is in fact used in many application as the important factor that is under evaluation. It is among other applications used to measure the roughness of a surface, in metrology and stellar speckle interferometry. In the following mathematical work there are some assumptions that need to be fulfilled(15).

1. These are that the light has to be perfectly coherent,
2. There are no phase fluctuations from the source,
3. The media does not depolarize the light
4. It is assumed that there are a very large amount of spreaders in the media spreading the light.

For more info on the mathematics and theory of speckle see the references (16) (15) and (9).

2.2 Speckle reduction methods in the near field

The different speckle reduction methods is as follows:

- Spatial averaging
- Temporal averaging
- Polarization diversity
- Angle diversity
- Wavelength diversity
- Temporal and spatial coherence reduction.

As Trisnadi(8) presents it, there are three parameters that speckle depend on. Angle, polarization and wavelength, and it is possible to achieve individual speckle configurations through diversification of these factors. When these speckle configurations are present within one integration time in the human eye or camera chip, the speckle patterns will overlap and add on an intensity basis.

The coherence length of the laser is also of interest, many lasers have coherence lengths in the range that the display systems are working with. But the coherence is in fact the one factor one have to break

up and destroy to a certain level to obtain a speckle contrast reduction without destroying the contrast of the picture so much that it deteriorate the image quality.

Diffractional optical element is a example of a device providing angle diversity to the speckle image. It is a big array of diffractional slits or a micro grating giving a modulated beam given by the slit opening of the grating holes.

2.3 Objective and subjective speckle

In (12) Subjective speckle is the speckle effects due to the observer himself including the numerical aperture of the detector and the position of the detector, the farther away from the screen the observer is the bigger the speckle will be detected. Objective speckle in the other hand is independent of the observer. (14) classifies objective speckle as the speckle stem from uneven illumination falling on the screen. The subjective is in (14) classified as the combination of roughness of the subject and finite aperture of the detector.

3. Choices made in this setup

A lot of work were done to get the right equipment to the right price, and it is important that the camera had a very low intensity threshold limit so that it was possible to detect the small variance in intensity on the top of a high intensity signal. The camera had to provide a high precision in the intensity in each cell also when closing in on the saturation level. Cameras from Sony, Jai, Pulnix and Lumenera were evaluated and prices were sought after. Secondly the camera needed to have a software solution or a hardware solution which were possible to import data to Labview. Lumenera Lu075m was selected due to low price to feature coefficient. The camera had very easy to use software to adjust exposure times and gain term and the interface were USB 2.0 which is a high speed commercially common interface on new computers. The camera is also monochromatic giving the high precision in the intensity level on all intensities also towards saturation. There are many industrial standard cameras requiring a data acquisition card to boot, boosting the price of the system very much. But cameras with good features are coming with GigE or USB 2.0 to a reasonable price is coming, they are still a little more expensive than cameras requiring a data acquisition card. Such data acquisition cards were sought up on National Instruments(11) and prices were given in the response. The cheapest alternative was a Single channel color/monochrome framegrabber to around 500 €. The cameras requiring such cards are analog while the new cameras providing GigE and USB 2.0 interface has got an analog to digital converter (10)

The detector was installed with a camera and a lens with 45mm lens to match the optics of a human eye. The picture that were evaluated were not modulated in any kind, it is possible to do this with a SLM, spatial light modulator like a GLV (Grating Light Valve) (7). But for simplicity the picture were made by a laser and a beam expander increasing the beam waist into a spot with 5mm diameter.

Diffusers were ordered from Edmund optics, these were sandblasted glass of different sand grain size. These were found to be so diffusing that it was not possible to use them in this setup. Failing any good industrial standard diffuser a plastic sheet from an ordinary clear plastic bag was used.

In this setup the plastic bag functioned as a diffuser giving an angle diversity of the laser light removing some of the spatial coherence of the laser light and reducing the speckle contrast.

The surface of this plastic film is rough compared to a wavelength and will make a speckle pattern on the screen, this speckle is then tried to be abolished.

3.1 The employed speckle reduction method

In this setup the speckle reduction method used could be classified as angle diversity, although there are no controlled angle diversity in the sense that the projector resolution spot is that much bigger than the detector resolution spot. But the speckle from the modulated diffuser will be travelling on the screen making the intensity in each detector resolution spot fluctuate in time, being integrated in the detector. The effect of this will be that the intensity fluctuations out of one detector resolution spot would destroy the contrast of the picture we are trying to emphasize. It is not possible with this setup to find the numbers for the contrast of the picture itself because it does not have any contrast, it is homogenous.

3.2 Expectations to the results of the chosen setup

There are several factors one can put out as an important one before setting up the test bench. First and foremost the modulation needs to be a displacement of over one speckle size and the modulation speed must have to be higher than the refreshing rate of the human eye, set to 60Hz on the detector. This means that since the displacement is a sine curve that the maximum displacement would have to be a bit bigger than the minimum one speckle grain. We want it to have a RMS value around that displacement of one speckle. This means that the will have to

In (6)

(Trekke inn hastigheter fra 'A practical Laser Projector' (6) og displacement fra forsøk fra 1971 (2))

De ulike faktorenes innspill i resultatene, polarisatorer, beamexpander, lasertype og divergensen. Kameraet, og linsejusteringen ned til chippen. Og ikke minst koherenslengden til laseren.

Work with a rotator for diffusers were also initiated, but the work were terminated after some time due to practical problems in making the device. This device could have provided a better speckle reduction coefficient due to all the different areas of point spreaders that would be shifted within one integration time of the detector. This would in turn provide a better adjustment control for the speed of the diffuser in the beam

There are several factors which one can alter in an optical setup to make the result a little different. Following, the main of this assignment, the different factors were altered to see the effects on the speckle size and the statistical properties of the image imported to Matlab.

As presented in chapter 2 in this project a diffuser that can produce two speckle patterns that are statistically independent within one integration time of the detector one will be reducing the speckle contrast with a factor of 1,414, the square root of two. The displacement will not move the laserspot out of the original spot on the plastic film so the speckles will be statistically dependant because the same light spreaders were used in the two speckle images, giving a speckle reduction factor of under 1,414. If the

With some adjustments it is possible to get the speckle grain size to a size that the camera array can dissolve, the best would be that the speckle size was about as big as 4 or 5 pixels, around 30 to 40 μm .

4. Practical results

4.1 The 10 sets of test

The chosen equipment for the setup:

Brüel & Kjær Accelerometer Preamplifier type 2626.

Brüel & Kjær Piezoelectric Accelerometer type 4344. (1)

Brüel & Kjær PM Mini shaker type 4810. (2)

Linear polarizer x 2 (3)

Beam expander 20x, Edmund Optics (4)

Copy Paper white (5)

Oscilloscope

DPSS laser (6)

Plastic sheet from a plastic bag, clear type. (7)

Plastic sheet from a plastic bag, clear type, mounted on a fixed arm. Not shown on the picture.

Luminera Industrial digital Camera, LU075M (8)

Lens, 45mm focus length, 2,5cm diameter (9)

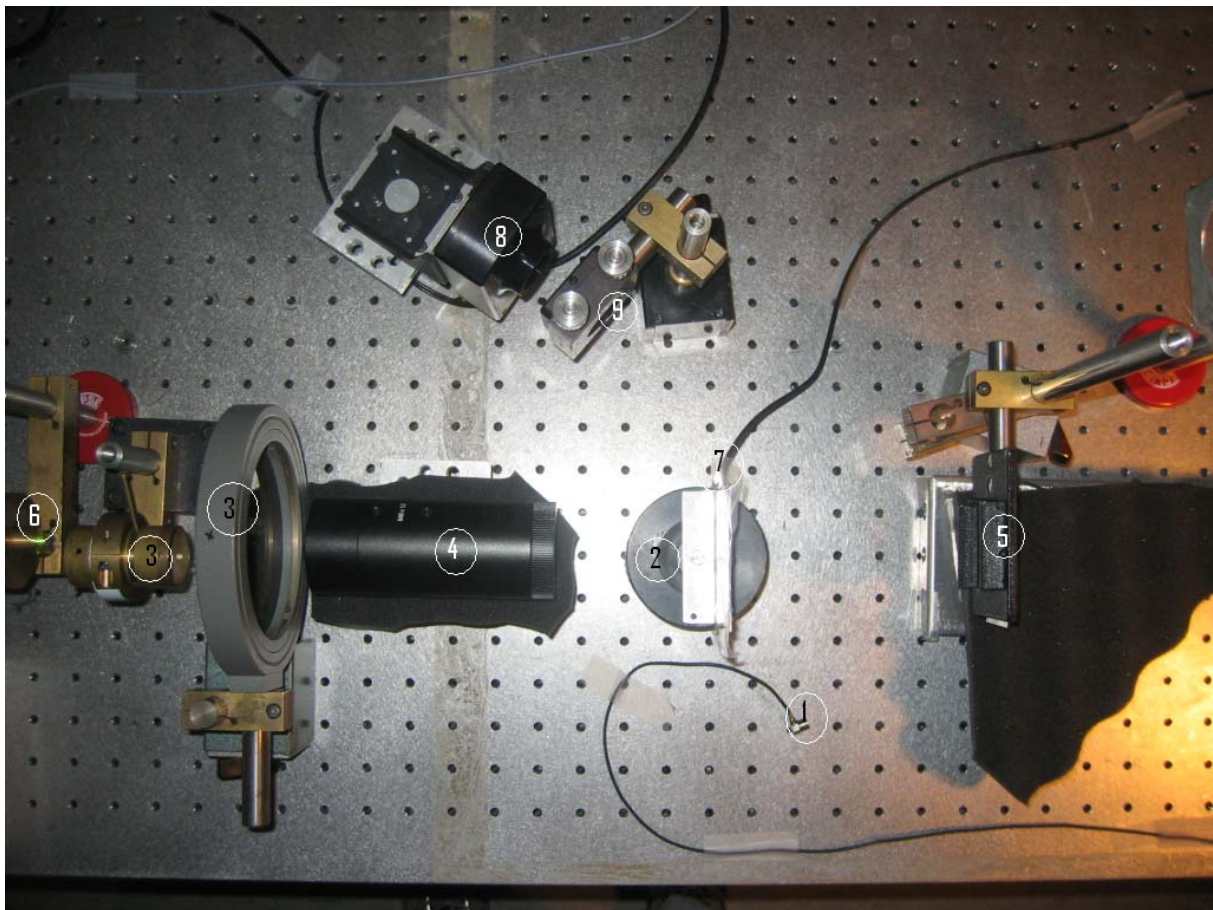

Figure 1, the setup with screen, diffuser, light source and detector plus optics.

The practical work are a series of tests with different factors being tweaked in each test set. The reason it is so many small series is to isolate different factor to easier address its role in this speckle reduction method.

For all these series of tests the camera was set at a distance of 30cm from the screen.

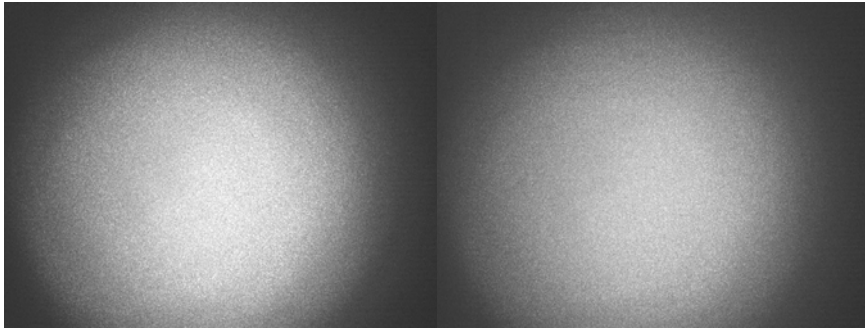

Figure 2a, Without diffuser.

Figure 2b, With single fixed diffuser.

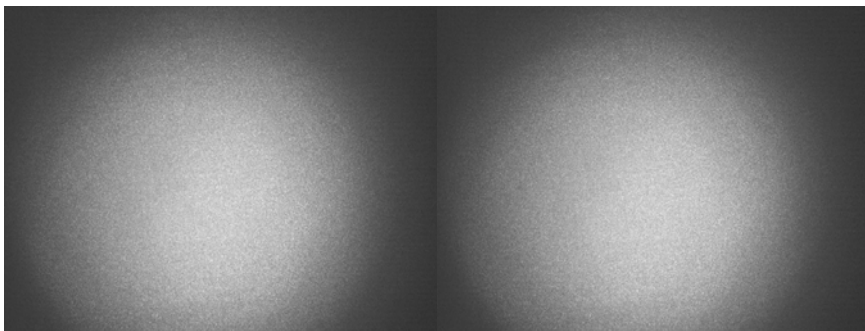

Figure 2c, Single diff, 200hz modulation.

Figure 2d, Single diff, 100hz mod.

The first series of test also introduces the concept of absorption in the diffuser, the more diffusers we use the more the mean intensity drops. The two linear polarizers were adjusted in and ended up blending out a big portion of the laser light, absorption in the polarizers material and reflection in the optics in the beam expander also dims the intensity of the light a little. That is why it is important to take account how many diffusers there are in the path of the light before one compares results from different settings, that is not taking the mean intensity data and as an important factor in this tests. This intensity drop is not very detectable when looking at the images. But there are no exceptions, the intensity always drops a little when introducing a module of any kind in the path of the light, this do not include optical intensifiers.

It is not easy to detect any difference in the variance or intensity in the pictures in figure 1 to 4. Therefore algorithms in Matlab were used to find the statistics of the different images, numbers on the standard deviation of the intensity value and the mean intensity were found. The signal was filtered so that it was possible to extract the small frequency and small amplitude speckle noise information. This information was evaluated statistically using the *std* and *mean* function in Matlab.

The first set utilizes none, one and two diffusers. The two diffusers is put up 5 millimeters from each other, the second one, farthest away from the screen, were modulated. These diffusers were positioned 15cm from the screen. Gain in the video software were set to 1,7 and exposure to 16ms on all these test runs. The gain were set to a fixed value, the actual value is of no certain interest since the two linear polarizers is adjusted so that the camera do not reach saturation in any region of the image.

	Standard dev.	Mean Value	Contrast
uten_diff	14,06	156,87	0,0896
medsingeldiff	11,44	142,14	0,0805
medsingeldiff100	11,34	143,54	0,079
medsingeldiff200	10,79	142,20	0,0759
medsingeldiff300	11,48	143,34	0,0801
meddobeldiff0	9,46	131,60	0,0719
meddobeldiff100	9,19	129,83	0,0708
meddobeldiff200	9,75	131,40	0,0742
meddobeldiff300	10,20	131,05	0,0778
meddobeldiff500	10,68	107,31	0,0995

Table 1. First set of tests

The results clearly show a reduction of almost 10% when introducing a new diffuser as expected. The contrast also show a reduction of 10% or a reduction factor of 1,11 when introducing a fixed diffuser, another 6% or a reduction factor of 1.06 when modulating this diffuser with 200Hz.

In the next set the distance between the two diffusers were set to 7,5cm, the diffuser farthest away from the screen is modulated on a 15cm distance from the screen, the fixed diffuser is then placed 7,5cm from the screen and 7,5cm from the modulated diffuser.

Picture	Standard dev.	Mean Value	Contrast
utendiff	20,35	173,38	0,1174
diff0	21,34	155,65	0,1371
diff200	18,22	152,13	0,1198
diff300	17,76	154,82	0,1147
diff500	17,66	150,40	0,1174
diff700	18,26	149,89	0,1218
doublediff0	13,26	117,12	0,1132
doublediff200	12,72	117,49	0,1083
doublediff300	12,56	117,51	0,1069
doublediff500	13,15	118,27	0,1112
doublediff700	12,96	118,78	0,1091

Table 2, Second set of tests

Here the same mean value drop occur then introducing the diffuser, but here the data gives a 17% higher speckle contrast when using one fixed diffuser than using no diffusers. This is unfortunate and stem from a flaw in the working process, and rerun of the whole set would be necessary to address this as a flaw. It is presumed it was a flaw because an accidental occurrence giving 17% higher speckle contrast is not believed to happen. Although the speckle contrast does not see that high of a reduction throughout this set, the biggest reduction factor is at the case where two diffusers are used one of them modulated with 200Hz. The Mean value in this set also drops drastically then adding the second diffuser maybe spreading the light so much that some are lost out of the cameras view. Since the diffusers are placed at a distance 7,5cm apart they will effectively spread the light much more than if they were placed next to each other.

Still the highest reduction in this set is only 10% or a reduction factor of 1.11. This is despite the fact that the mean value of the intensity fell with 32%.

In the third set the distance was set to 3,5cm, the modulated diffuser still positioned 15cm from the screen and the fixed diffuser 12,5cm from the screen.

Picture	Standard dev.	Mean Value	Contrast
doublediff0	13,96	123,08	0,1134
doublediff200	13,80	124,71	0,1107
doublediff300	13,91	124,30	0,1119
doublediff500	14,23	125,11	0,1137
doublediff700	14,46	124,83	0,1158

Table 3, Third set of tests

Here the modulation are 200, 300, 500 and 700 Hz, and the results seem to give a tendency that the contrast reduction is best at 200Hz but the reduction is only 2,4% or a reduction factor of 1,024.

Fourth series there were taken two images that will be added up in intensity. The images were taken when the diffuser were moved 6mm perpendicular to the laser beam. The diffuser was 13cm from the screen.

Picture	Standard dev.	Mean Value	Contrast
nullmm	16,53	135,85	0,1217
seksmm	16,77	134,70	0,1245
sammen	11,83	135,52	0,0873

Table 4, Fourth set of tests

These two pictures look the same and have almost the same contrast and mean value, but when they are added together the results here are very nice. The reduction is 28,3% or a reduction factor of 1,3939 at so far from the theoretical 1.4141 reduction when adding two statistically independent speckle patterns. It would be great if this 6mm shift could be done within one integration time of the detector.

The Fifth set introduces the concept of modulating the screen, without any other diffusers.

Picture	Standard dev.	Mean Value	Contrast
0	21,09	160,52	0,1314
100 Hz	4,47	159,00	0,0281
200 Hz	6,89	159,10	0,0433
300 Hz	5,80	158,52	0,0366
400 Hz	5,83	158,50	0,0368
600 Hz	10,11	157,91	0,0640
800 Hz	7,57	158,41	0,0478
1000Hz	14,34	157,26	0,0912
1200Hz	17,59	157,19	0,1119

Table 5, Fifth set of tests

With an angle of 30 degrees the optical path length difference with a modulation of the screen will be $1+\cos(30)$ multiplied by the peak to peak swing of the modulator. Here it is assumed that the screen were mounted in a way that it would fall back to the start position when the swing goes back and that the screen sheet follows the movement of the modulator at all times, the second assumption is that the sheet do not apply any workload to the modulator. This means the results from table 11 will be applicable in this case. The displacement is in fact maybe better than table 11 due to the element laying on the side not having the weight of the table as a brake in the system. The displacements in table 11

The results from this set are very good for reducing speckle contrast, here a modulation of 100 Hz reduces the speckle contrast with 78,6% or a reduction factor 4,67. Here we can see that the speckle reduction becomes less and less when using high modulation frequencies, at 1200Hz the speckle reduction is only 15%, that is much compared to the other sets but very different from the result with frequencies up to 800Hz in this set. The reduction stays high

Here also the picture alters when the modulator is turned on, this would greatly introduce blurring of the actual picture we would like to draw attention to.

In the sixth set were set up like the fifth only here a fixed diffuser is introduced at 15cm distance from the screen.

Picture	Standard dev.	Mean Value	Contrast
0	12,75	137,57	0,0927
100	2,78	136,94	0,0203
200	3,56	136,81	0,0260
300	4,69	136,75	0,0343
400	5,87	136,73	0,0429
600	8,19	137,00	0,0598
800	10,67	137,51	0,0776
1000	11,11	137,44	0,0808
1200	12,75	137,86	0,0925

Table 6, Sixth set of tests

Here we see the same speckle contrast reduction, so the introduction of a fixed diffuser did not do any good to the speckle removal. It was only a loss term reducing the mean value with 14%. Here we see the same trend in the contrast increasing as the frequency increases over 100 Hz. But here the contrast increases evenly up to 1200 Hz mark. That is probably more right than what the last set showed on this matter.

In the seventh set two diffusers were used and moved within each other and also in reference to the screen.

Picture	Standard dev.	Mean Value	Contrast
first	15,28	126,00	0,1213
second	14,13	125,23	0,1128
third	14,23	124,49	0,1143
fourth	14,50	125,84	0,1152
fifth	14,36	122,54	0,1172
sixth	14,93	121,17	0,1232

Table 7, Seventh set of tests

Here the diffusers were close to each other on the first image increasing from 0,5cm in first image to 8cm in fourth. And up to 0,5cm again letting the one farthest away from the screen catch up the diffuser that was closest to the screen. The results are not very clear but it can be interpreted that the increase in distance has a higher speckle reduction effect up to a certain level. The distance in the second picture is 2cm and in the third picture 5cm. It looks like it does not help increasing the distance more when at 2cm giving a maximum contrast reduction of 7%.

The eight set utilizes only one diffuser which was modulated at three different distances from the screen.

Picture	Standard dev.	Mean Value	Contrast
9cm0freq	16,94	177,03	0,0957
9cm100	15,60	175,31	0,0890
9cm200	16,31	175,34	0,0930
14cm0freq	17,32	173,38	0,0999
14cm100	15,41	174,13	0,0885
14cm200	17,08	172,71	0,0989
17cm0freq	14,89	174,20	0,0855
17cm100	15,71	173,84	0,0904
17cm200	16,45	171,32	0,0960

Table 8, Eight set of tests

In this set the interesting part is looking at the cases with the same frequency but with different positions. The case where the diffuser is 9cm from the screen we see that the speckle contrast is right under 0,1 with no modulation and even closer to 0,1 with a distance of 14cm. Then it drops to 0,0855 in the case where it is 17cm from the screen. Looking at the 100Hz modulation images it suggest a reversed case where the speckle contrast goes down a little when looking at the 9cm100 and the 14cm100 images. The 17cm100 indicated a little increase again, which leads to the conclusion that these results are to close in values to prove that there are any coherence between the placement of the diffuser and speckle reduction. This could be because one diffuser alone do not spread so much that one can see the results on so small distances.

In Ninth Set a simple fixed diffuser were moved transversally to different spots on the diffuser overlapping less and less with the area first illuminated in the first image. The second is four fifth of the area lighted by the first, the third is 3 fifth and so on. The fifth is illuminating a totally new area of the plastic film. This test is done to see whether a displacement to a 3 fifth of the area not overlapping any region on the plastic film.

Picture	Standard dev.	Mean Value	Contrast
first	9,76	85,25	0,1145
second	8,92	83,76	0,1065
third	9,15	83,98	0,1090
fourth	8,92	83,64	0,1067
fifth	8,99	82,78	0,1086
sixth	9,05	86,25	0,1049
first+second	5,73	61,25	0,0936
first+third	5,40	61,48	0,0878
first+fourth	5,11	61,01	0,0838
first+sixth	5,38	62,68	0,0859

Table 9, Ninth set of tests

By only looking at the contrast data and standard deviation this set does not give any interesting information, the reason why this set was included in the sets is to expand the idea introduced in the fourth set a little. In the fourth set the relocation was 6mm, but here the relocation is based on the spot size, slightly moving the spot out of the area it illuminates in the first picture. We can see that the speckle contrast falls when combining speckle images from plastic film with their center farther apart from that of the first image. This set was done with a not so good adjustment possibilities making the data a little bad.

The tenths set is as ninth only with better equipment able to adjust the movement with a millimeter peg.

Picture	Standard dev.	Mean Value	Contrast
40mm	9,30	88,23	0,1054
40point5mm	9,41	90,03	0,1045
41mm	9,41	90,03	0,1045
41point5mm	8,91	89,93	0,0991
42mm	9,80	89,98	0,1089
40point5mm + 40mm	5,69	64,03	0,0888
41mm + 40mm	6,03	63,81	0,0945
41point5mm + 40mm	5,55	64,06	0,0866
42mm + 40mm	5,47	63,47	0,0882

Table 10, Tenth set of tests

The pictures names are the position of the millimeter peg. And the 4 last lines are the addition of these divided by two. It was expected that the contrast value would drop more and more the farther away the two images that is combined are taken with. It seems that there are no such conclusion in this set. The only trend which one can be certain of is the drop in the speckle contrast when combining to different speckle patterns from two different pictures. The statistical independency of the small diffuser elements in the diffuser film does not seem to give any difference in the speckle here. In retrospect thinking the laser spot is 5mm wide on the film it would be interesting to go further with this set up to 5mm maybe it would be possible to see that the dependencies of the diffuser elements does play a role in the speckle reduction.

4.2 The displacement of the modulator

One task includes getting the data from the accelerometer through a preamplifier and interpret the signals one get from the oscilloscope. The accelerator gives out a sine function as the Pulse/function generator is set to a sine. But the signal given out on the oscilloscope is the acceleration of the modulator, it need to be double-integrated back to displacement, so that we can investigate the maximum displacement at a given frequency and load.

So when we double integrate the a factor here being ω or $2\pi f$, a $1/a^2$ factor will result making the displacement very much

$$\int \sin(ax) dx = -\frac{1}{a} \cos(ax) + c \quad (1)$$

$$\int \cos(ax) dx = \frac{1}{a} \sin(ax) + c \quad (2)$$

Results without workload only measuring equipment 2,5g:

Freq	Voltnivå	Aks-amp	V.denom	Vmax (m/s)	V_RMS	denominator	displ. Amp	displ.pp.
10	0,00	0				3,95E+03	0,00E+00	0,00E+00
30	0,25	3,46	1,88E+02	1,84E-02	1,30E-02	3,55E+04	9,75E-05	1,95E-04
50	0,80	11,09	3,14E+02	3,53E-02	2,50E-02	9,87E+04	1,12E-04	2,25E-04
70	2,00	27,72	4,40E+02	6,30E-02	4,46E-02	1,93E+05	1,43E-04	2,87E-04
90	3,00	41,58	5,65E+02	7,35E-02	5,20E-02	3,20E+05	1,30E-04	2,60E-04
100	3,00	41,58	6,28E+02	6,62E-02	4,68E-02	3,95E+05	1,05E-04	2,11E-04
200	2,40	33,26	1,26E+03	2,65E-02	1,87E-02	1,58E+06	2,11E-05	4,21E-05
400	2,00	27,72	2,51E+03	1,10E-02	7,80E-03	6,32E+06	4,39E-06	8,78E-06
600	2,00	27,72	3,77E+03	7,35E-03	5,20E-03	1,42E+07	1,95E-06	3,90E-06
800	2,00	27,72	5,03E+03	5,51E-03	3,90E-03	2,53E+07	1,10E-06	2,19E-06
1000	2,00	27,72	6,28E+03	4,41E-03	3,12E-03	3,95E+07	7,02E-07	1,40E-06
2000	1,80	24,95	1,26E+04	1,99E-03	1,40E-03	1,58E+08	1,58E-07	3,16E-07
3000	1,75	24,25	1,88E+04	1,29E-03	9,10E-04	3,55E+08	6,83E-08	1,37E-07
4000	1,60	22,17	2,51E+04	8,82E-04	6,24E-04	6,32E+08	3,51E-08	7,02E-08

Table11. Results without workload

These are the results with 17,5g of load, the diffuser weighs 17,5g:

Freq	Volt lvl	Aks-amp	V.denom	Vmax (m/s)	V_RMS	dipl. Denom	displ. Amp	displ.pp.
10	0,00	0					0,00E+00	0,00E+00
20	0,00	0					0,00E+00	0,00E+00
30	0,30	4,16	1,88E+02	2,21E-02	1,56E-02	3,55E+04	1,17E-04	2,34E-04
40	0,50	6,93	2,51E+02	2,76E-02	1,95E-02	6,32E+04	1,10E-04	2,19E-04
50	1,00	13,86	3,14E+02	4,41E-02	3,12E-02	9,87E+04	1,40E-04	2,81E-04
60	1,40	19,40	3,77E+02	5,15E-02	3,64E-02	1,42E+05	1,37E-04	2,73E-04
70	1,60	22,17	4,40E+02	5,04E-02	3,57E-02	1,93E+05	1,15E-04	2,29E-04
80	1,50	20,79	5,03E+02	4,14E-02	2,92E-02	2,53E+05	8,23E-05	1,65E-04
90	1,40	19,40	5,65E+02	3,43E-02	2,43E-02	3,20E+05	6,07E-05	1,21E-04
100	1,25	17,32	6,28E+02	2,76E-02	1,95E-02	3,95E+05	4,39E-05	8,78E-05
150	1,00	13,86	9,42E+02	1,47E-02	1,04E-02	8,88E+05	1,56E-05	3,12E-05
200	1,00	13,86	1,26E+03	1,10E-02	7,80E-03	1,58E+06	8,78E-06	1,76E-05
300	0,85	11,78	1,88E+03	6,25E-03	4,42E-03	3,55E+06	3,32E-06	6,63E-06
400	0,80	11,09	2,51E+03	4,41E-03	3,12E-03	6,32E+06	1,76E-06	3,51E-06
500	0,95	13,17	3,14E+03	4,19E-03	2,96E-03	9,87E+06	1,33E-06	2,67E-06
600	1,00	13,86	3,77E+03	3,68E-03	2,60E-03	1,42E+07	9,75E-07	1,95E-06
700	1,00	13,86	4,40E+03	3,15E-03	2,23E-03	1,93E+07	7,16E-07	1,43E-06
800	1,20	16,63	5,03E+03	3,31E-03	2,34E-03	2,53E+07	6,58E-07	1,32E-06
900	1,50	20,79	5,65E+03	3,68E-03	2,60E-03	3,20E+07	6,50E-07	1,30E-06
1000	1,80	24,95	6,28E+03	3,97E-03	2,81E-03	3,95E+07	6,32E-07	1,26E-06
1100	2,60	36,03	6,91E+03	5,21E-03	3,69E-03	4,78E+07	7,54E-07	1,51E-06
1200	2,55	35,34	7,54E+03	4,69E-03	3,31E-03	5,68E+07	6,22E-07	1,24E-06
1300	2,75	38,11	8,17E+03	4,67E-03	3,30E-03	6,67E+07	5,71E-07	1,14E-06
1400	1,00	13,86	8,80E+03	1,58E-03	1,11E-03	7,74E+07	1,79E-07	3,58E-07
1500	2,75	38,11	9,42E+03	4,04E-03	2,86E-03	8,88E+07	4,29E-07	8,58E-07
1600	1,45	20,10	1,01E+04	2,00E-03	1,41E-03	1,01E+08	1,99E-07	3,98E-07
1700	1,00	13,86	1,07E+04	1,30E-03	9,17E-04	1,14E+08	1,21E-07	2,43E-07
1800	0,60	8,32	1,13E+04	7,35E-04	5,20E-04	1,28E+08	6,50E-08	1,30E-07
1900	0,45	6,24	1,19E+04	5,22E-04	3,69E-04	1,43E+08	4,38E-08	8,75E-08
2000	0,15	2,08	1,26E+04	1,65E-04	1,17E-04	1,58E+08	1,32E-08	2,63E-08
3000	3,00	41,58	1,88E+04	2,21E-03	1,56E-03	3,55E+08	1,17E-07	2,34E-07
4000	0,40	5,54	2,51E+04	2,21E-04	1,56E-04	6,32E+08	8,78E-09	1,76E-08

Table12. Results with 17,5g workload

With a sinusoidal signal the RMS value of the speed will be found by simply dividing the amplitude with the root of 2. This value is interesting in this case due to comparisons with other works on this issue, where some operate with speed and other with displacement. The speed is found by integrating the acceleration once giving the denominator $2\pi f$, so the speed is always a factor $1/2\pi f$ smaller than the acceleration. In the same way the displacement is a factor $(1/2\pi f)^2$ smaller than the acceleration.

Max displacement, looking at the 'displ.p.p' column giving the peak-to-peak value of the sine, is at 50 Hz mark with a displacement of almost 0,3mm with the 17,5g workload. Without workload max displacement was also around 0,3mm, but this is at 70Hz mark. These numbers show a much smaller displacement than that given in the data sheet of the PM Mini-Shaker type 4810 graphs which shows the response in displacement with a given load and frequency. This I probably due to miss earlier miss use and wear of the element. But such a big displacement as the data sheet provides is not necessary to reduce speckle in this setup.

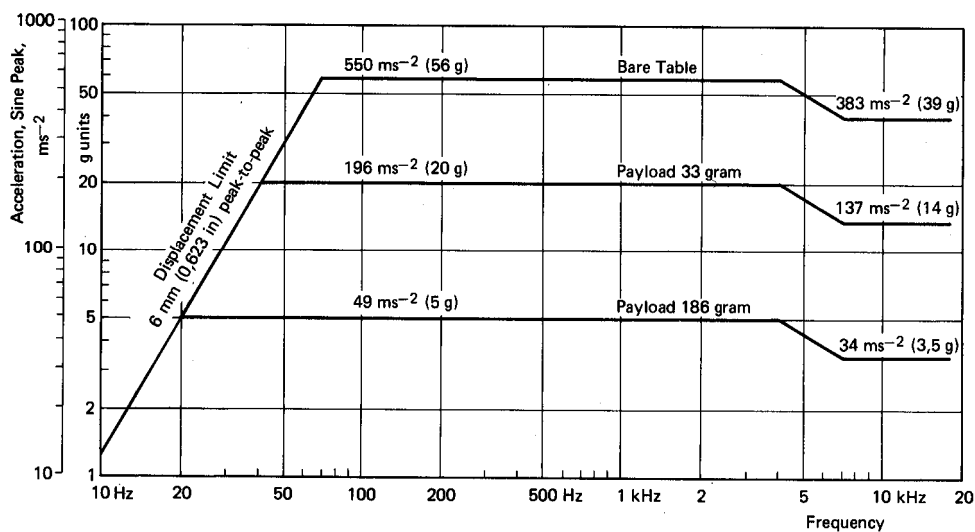

Figure 3. Performance limits of the 4810 Mini-Shaker

Figure 11 shows that it is possible to reach a 6mm displacement at a limit up to 70 Hz, and over that the displacement goes in saturation. The bigger the payload the farther down on the frequency axis the saturation point comes. This means that it is theoretically not possible to achieve the maximum displacement of 6mm on frequencies over 70Hz. This plot shows that it is, if possible, best to modulate with a low frequency. At the same time due to the detector frame rate the modulation needs to be higher than 60Hz. So if one wishes a higher displacement one need to modulate with frequencies around the saturation point for the given payload.

To comment a little further on the results for the frequencies that were believed to be the key frequencies for use in such optical setups, the displacement at 200Hz is almost a tenth of what it is at 100Hz. This will indicate that if the displacement is close to the limit or too small at 200Hz, that is the displacement is in the same order as the speckle size, the 100Hz mark would be the preferred frequency when modulation both the diffuser and/or the screen. The eye has a refresh rate of slower than 100Hz so all signals with frequency 100Hz or higher the human eye cannot detect any fluctuations in the signal. Here the detector were set to a smaller frequency of 60Hz giving the 100Hz modulated signal enough time to at least take one period of the signal in one integration time limit. This is for integrating over the different diffracted images we make with a moving diffuser and to provide for the speckle in the signal to be reduced like in an human eye with the same setup.

4.3 Calculation of the flying middle of the beam curvature

To find the variance of the beam form, the intensity variation perpendicular to the beam, the signal has to be compared to the filtered out beam form so that one can get the small frequency and low amplitude information on top of the beam form. This information is the noise from speckle. To do that a summing algorithm were used to find the mean in every fraction of the curvature. In the code in appendix A.1 several iterations with different length were used. It is very much possible just to use a second for-loop if all were of the same length, but the results of the lengths of these samples are somewhat empirical. It is beneficial to adjust individual iteration with regards to finding the right sample length and the right could be if could be put inside another for-loop. Small

The mode-image of the laser comes in as an important factor, it is not intended to filter the signal so much that the mode intensity variation is mistakenly included in the intensity variation due to speckle. The intensity curve used in this work is in fact not a Gaussian curve but rather a Gaussian curve multiplied by a mode intensity variation, this is apparent when expanding the beam as were done in this work, and this mode variation can be detected easily by looking at the pictures.

Due to this mode intensity variation there is no given limit for the filtering, and this filtering may be one of the biggest sources of error in this setup when trying to find certain numbers of the speckle information statistics. As mentioned in expectations to the practical work the speckle grains should be bigger than 3x3 pixels and should not be bigger than 7x7 so that the mean operation could use iterations of length around 15 to even out this noise.

To evaluate the iteration number and the mistake one make when reducing the number of iterations an example from the sixth set is presented.

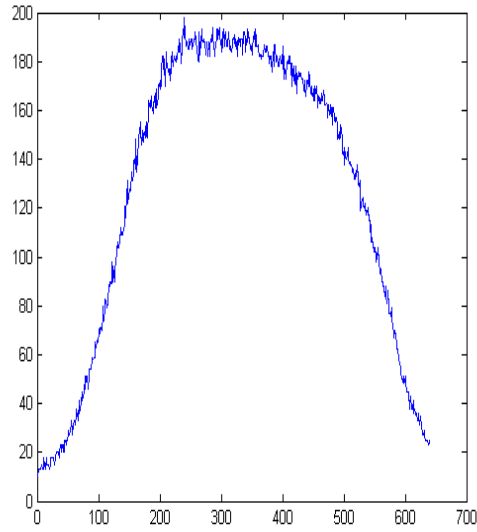

Figure 4, Curvature with 100 Hz

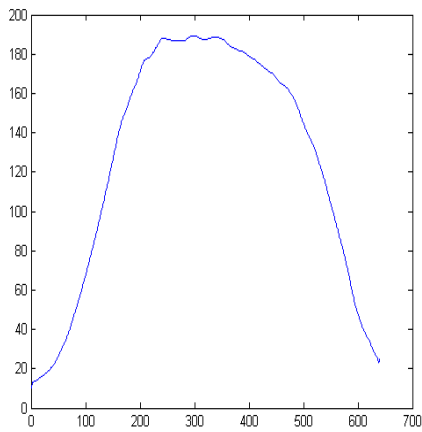

Figure 5, 5 iterations

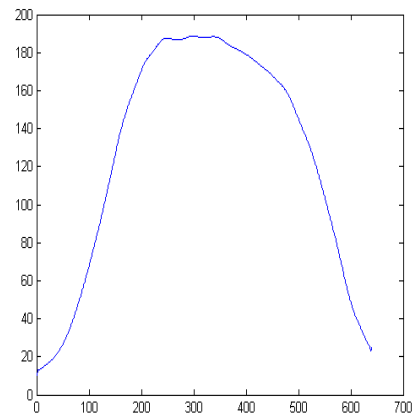

Figure 6, 12 iterations

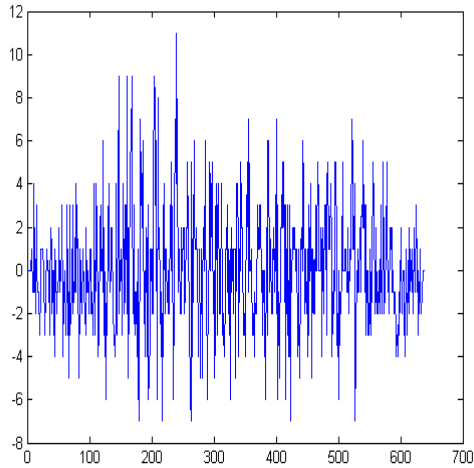

Figure 7, the noise info after 5 iterations

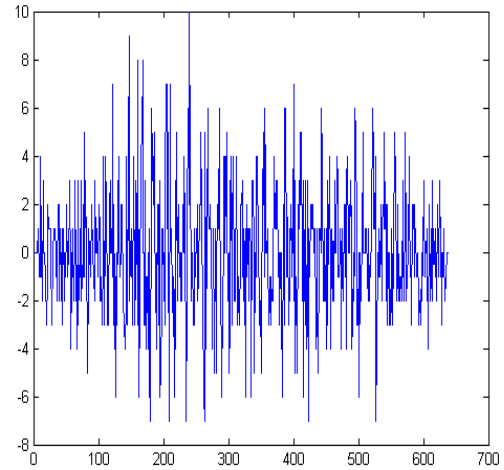

Figure 8, the noise info after 12 iterations

Using the algorithms on the picture taken with 100Hz modulation in the sixth set 12 iterations gives:

Standard deviation = 2.8298, Contrast = 0.0224

Compered to 5 iterations:

Standard deviation = 2.7147, Contrast = 0.0215

The figures 7 and 8 show 5 and 12 iteration respectively indicating that the mistake when using the 5 iteration case instead of the 12 is not that great, also making the computer work less per image when processing many pictures and lines in each picture. The numbers also gives a good support for using fewer iterations than 12 without big mistake. The number of iterations for the test are random, it is not the case that 12 iterations is the best and the correct amount of iterations.

The percentage of error one make when using 5 iterations instead of 12 is 4%. And as long as all the pictures in the same set were run with the same iterations that error is of no further concern.

4.4 Measured Speckle size

To find the actual speckle grain size we need to look at an example image and evaluate the period of the small fluctuations. This is to verify that a large enough displacement was used in the practical work. The first picture in the 4th set has been used as an example; here a single fixed diffuser is used giving the actual speckle grains we wish to move.

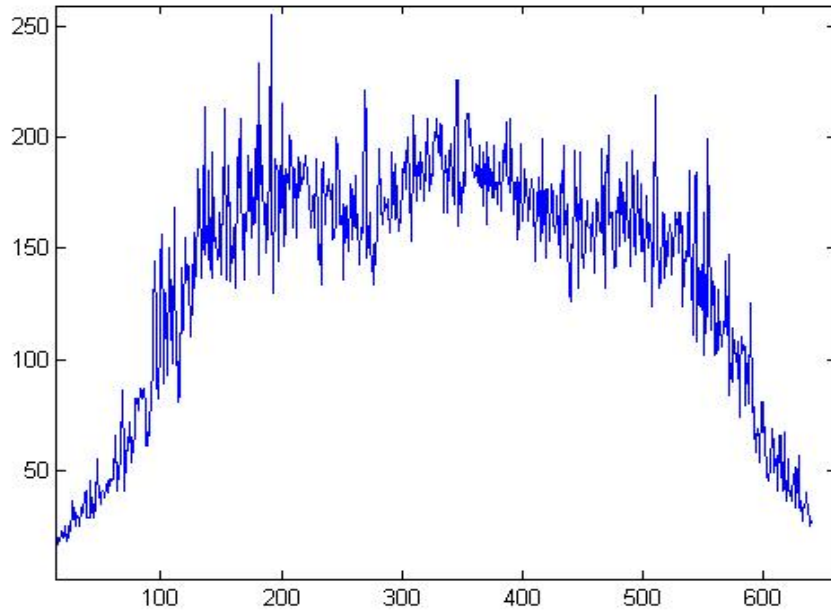

Figure 9, Direct plot of a line in the picture.

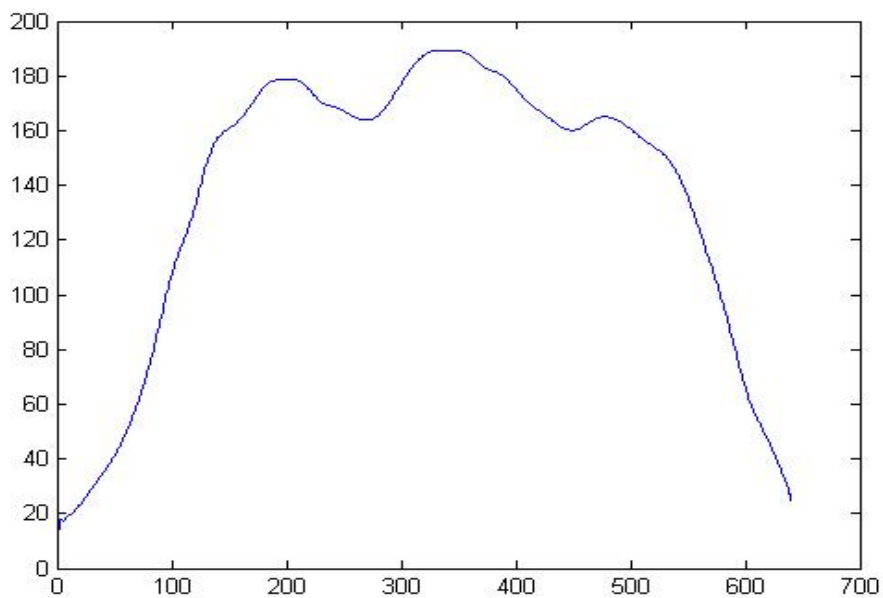

Figure 10, Filtered out signal, signal without speckle.

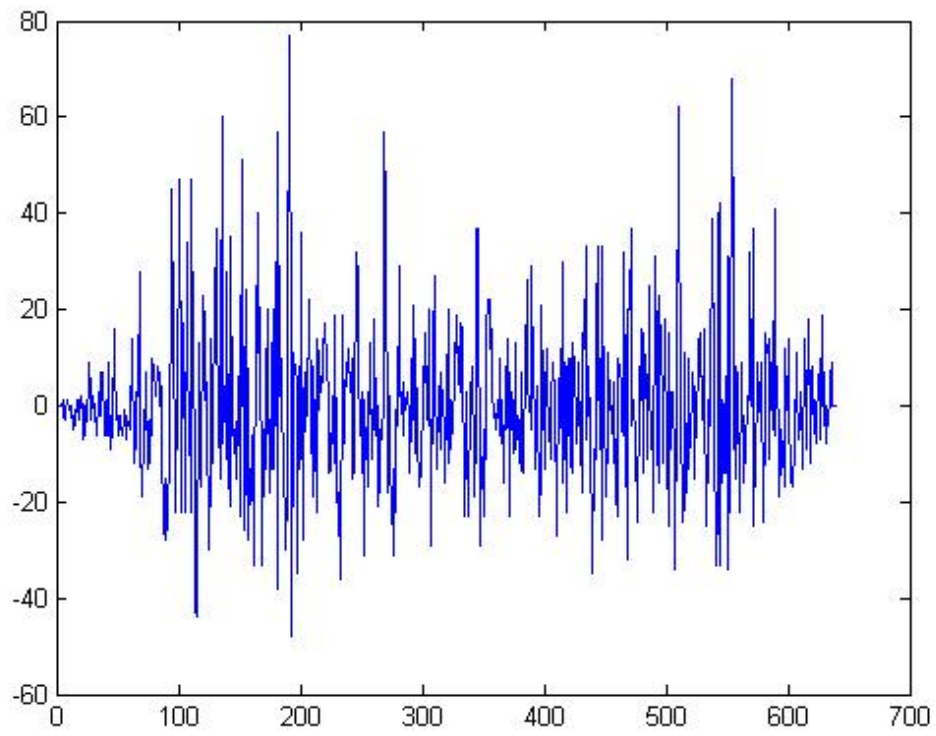

Figure 11, Speckle signal filtered out of the curvature.

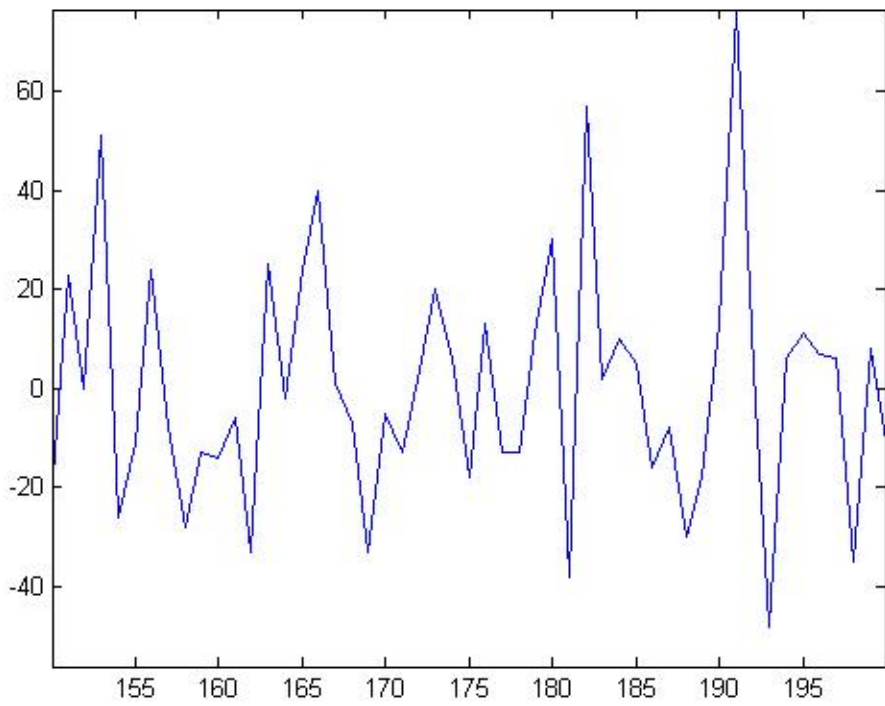

Figure 12, The speckle grains zoomed in to a range of 50 pixels.

Figure 12 shows a zoomed image of the speckle signal and it is possible to count the number of speckle grains in the range 150 to 200. Within this range there are roughly 10 tops giving the speckle grain size of 5 pixels which are $7.4 \mu\text{m}$ wide. So one speckle is in this picture $37 \mu\text{m}$ wide. Remember that the tops in figure 12 are not in fact 10, but the speckles are also not centered on the line this plot is taken from. The speckle size is the period of the lowest frequency component in the picture.

5. Discussion

There were sadly no time for deriving a mathematical model for speckle in this project, this would have been very interesting and would be able to show the mathematical nature of speckle and diffusers in a more thorough manner giving the bigger view on the total picture of the problem of speckle. A Hadamard matrix(16) would also be a would have been produced as a single device and the production process for such prototypes are very high.

Could have been better to adjust up the intensity so that all the pictures were taken with highest possible mean intensity and all the images were taken with intensity near saturation. The tests were run with the same gain factor and the same polarizer adjustments regardless of number of diffusers. Adjusting the gain or polarization opening would maybe give a little better ground for comparing the numbers for the contrast a little better.

The tests that required two modulators also were canceled due to that it was a challenge just getting hold of one modulator making it more time consuming or expensive to get a hold on two of them. This is unfortunate because the results are not believed to be that much better than just one type of modulation isolated, so that would be interesting to point out. This effect is due to the nature of the method, given the work of Trisnadi(8) and the maximum speckle reduction. The two methods of modulation would fall in the same category of angle diversity making them inmultipliable. It is possible to achieve a better reduction but that is only when each one of them are not optimal in the isolated cases, but this factor will be smaller than if two methods of different category was used. These categories are given in chapter 2 in this project.

It could also be interesting to add some testing with the modulation of the position of the laser module directly making the laser beam path shift back and forth in space with a little marginal value. But the only modulator available was a big vibration table with a hard nozzle making it incapable of providing the modulation required by such methods.

A modulation of the intensity of the signal driving the modulator would be very interesting in the screen modulation case looking at smaller displacements at any given frequency.

In retrospect the third set should be run with the same test points as in the second set. The sets are alike but the fact that the distance between the diffusers was changed. If the sets were built up with the same test points the data would be more interesting providing a comparable ground for the two sets.

There were a few things that could have been done better so that one could be hundred percent sure that the data given is the correct one for that test point.

A source of error could be the filtering of the beam form. It could be introducing big errors due to the fact that it is no absolute value of iterations in the process or any specific frequency components that can be removed without destroying the intensity that would be detected when there was no speckle in the system. It has however been show that the mistake one make when doing 5 iterations with 9 segments instead of 12 is not that great. But it could be that it is better using segments of different lengths in the different iterations.

When it comes to the displacement it is in fact too small for frequencies over 100 Hz, giving the optimal frequency for this setup to be 100Hz. The speckle grains were measured to be half that of the

100Hz displacement but over two times that of the 200 Hz displacement with a 17,5g of workload.
The speckle were exactly of the size that was

6. Conclusion

A lot of work remains on this issue to find a good solution for reducing speckle, this work has shown one method for reducing speckle trying to classify the diffuser as a possible method for reducing speckle in any way for a consumer market display system. The results show positive trends in this method and also the modulation of the screen itself. In this work the screen was a little sheet of paper, but the challenging task of testing a vibrating screen and use of plastic films as diffusers in big scale consumer displays maybe is carried out by a company as this report is written or maybe also many years ago. The use of plastic films in such systems does not give any troubles with the dimensions, the film is small and it is room for many such modules in a projector. Whether such films really are good enough for such systems will first be answered when it is implemented and tried out with this system. But from the results of this work it will demand more than just a modulated diffuser or a modulated screen. If only one of the methods should be implemented in a prototype it would first be interesting to carry out work with a modulated screen, this method showed to have good potential. This will also not have to be one of the complicated parts in the projector but in fact a second product belonging to the projector.

The results are not clear on the fact that it is usable in display systems or not, and it will probably smooth out the different pixels in the picture when applied to a display system with chromatic light and a changing image like a raster-scanned(9) or a line-scanned(9) display system. If the resolution spot division do not follow the rules given in chapter 2 of this report, the picture will be smeared out and the contrast of the picture will soar.

7. References

- (1) **Speckle reduction in Laser projection systems by diffractive optical elements**, Lingli Wang, Theo Tschudi, Thorsteinn Halldórsson and Pálmi R. Pétursson. *Applied Optics* Vol 37 No.10, 1. April 1998.
- (2) **Speckle Removal by a Slowly Moving Diffuser Associated with a Motionless Diffuser**, Serge Lowenthal & Denis Joyeux, *Journal of the Optical Society of America*, Vol 61, NR.7 July 1971.
- (3) **Speckle-free rear-projection screen using two close screens in slow relative motion**, Eric G. Rawson, Antonio B. Nafarrate & Robert E. Norton, Joseph W. Goodman. , *Journal of the Optical Society of America*, Vol 66 No 11 November 1976.
- (4) **Some fundamental properties of speckle**, J. W. Goodman, *Journal of the Optical Society of America*, Vol 66 No 11 November 1976.
- (5) **Speckle Reduction Using Multiple Tones of Illumination**, Nicholas George & Atul Jain, *Applied Optics* Vol. 12 No. 6 June 1973.
- (6) **A Practical Laser Projector with New Illumination Optics for Reduction of Speckle**, Noise, K. Kasazumi, Y. Kitaoka, K. Mizuuchi & K. Yamamoto, *Japanese Journal of Applied Physics* Vol. 43 No. 8B, August 2004
- (7) **Optical Performance of the Grating Light Valve Technology**, David T.Amm & Robert W.Corrigan, *Photonics West-Electronic Imaging '99. Projection Displays V. 1999*
- (8) **Speckle contrast reduction in laser projection displays**, Jahja I. Trisnadi, www.siliconlight.com/webpdf/Speckle_SPIE.pdf
- (9) **Speckle Phenomena in Optics, Theory and Applications**, J. W Goodman, Chapters 1, 2, 3, 5 & 6. Roberts & Company, 2007
- (10) **Wikipedia, the free encyclopedia**, www.wikipedia.com
- (11) **National Instruments**, www.ni.com
- (12) **Laser speckle exp for students** A. E. Ennos, University of Surrey,
- (13) **Some fundamental properties of speckle**, J. W. Goodman. Dept of El. Eng. Stanford
- (14) **Speckle reduction Using Multiple Tones of Illumination**, Nicolas George and Atul Jain, *Applied Optics* Vol.12 No.6 1973.
- (15) **Laser Speckle and Related Phenomena (Topics in Applied Physics; V. 9)** J. C. Dainty, Springer, 1976.

- (16) **Prosjekt om speckle i Laserdisplay**, *Anders Liffeld*, NTNU January 2007.

8. Appendix

A.1 Matlab Code

A.1.1 Code for filtering the beam profile

```
function []=midling()
I=imread('andreserie\diff.bmp');%E=finnemidtrad()
U(1:640)=I(360,1:640);%husk å benytt finnemidtrad() for hvert bilde først
P=uint16(U);
figure(1);
plot(P);
%-----

Q=zeros(640,1);
Q(1:5)=P(1:5);
for(i=5:636)
    Q(i)=(P(i-4)+P(i-3)+P(i-2)+P(i-1)+P(i)+P(i+1)+P(i+2)+P(i+3)+P(i+4))/9;
    i=i+1;
end
Q(637:640)=P(637:640);
figure(2);
plot(Q)
%-----

Y(1:5)=Q(1:5);
for(i=5:636)
    Y(i)=(Q(i-4)+Q(i-3)+Q(i-2)+Q(i-1)+Q(i)+Q(i+1)+Q(i+2)+Q(i+3)+Q(i+4))/9;
    i=i+1;
end
Y(637:640)=Q(637:640);
figure(3);
plot(Y)
%-----

E(1:4)=Y(1:4);
for(i=5:636)
    E(i)=(Y(i-4)+Y(i-3)+Y(i-2)+Y(i-1)+Y(i)+Y(i+1)+Y(i+2)+Y(i+3)+Y(i+4))/9;
    i=i+1;
end
E(637:640)=Y(637:640);
figure(4);
plot(E);
%-----

W(1:4)=E(1:4);
for(i=5:636)
    W(i)=(E(i-4)+E(i-3)+E(i-2)+E(i-1)+E(i)+E(i+1)+E(i+2)+E(i+3)+E(i+4))/9;
    i=i+1;
end
W(637:640)=E(637:640);
figure(5);
plot(W)
%-----

A(1:4)=W(1:4);
for(i=5:636)
    A(i)=(W(i-4)+W(i-3)+W(i-2)+W(i-1)+W(i)+W(i+1)+W(i+2)+W(i+3)+W(i+4))/9;
```

```

    i=i+1;
end
A(637:640)=W(637:640);
figure(6);
plot(A)
%-----

Z(1:4)=A(1:4);
for(i=5:636)
    Z(i)=(A(i-4)+A(i-3)+A(i-2)+A(i-1)+A(i)+A(i+1)+A(i+2)+A(i+3)+A(i+4))/9;
    i=i+1;
end
Z(637:640)=A(637:640);
figure(7);
plot(Z)
%-----

S(1:4)=Z(1:4);
for(i=5:636)
    S(i)=(Z(i-4)+Z(i-3)+Z(i-2)+Z(i-1)+Z(i)+Z(i+1)+Z(i+2)+Z(i+3)+Z(i+4))/9;
    i=i+1;
end
S(637:640)=Z(637:640);
figure(8);
plot(S)
%-----

V(1:4)=Z(1:4);
for(i=5:636)
    V(i)=(S(i-4)+S(i-3)+S(i-2)+S(i-1)+S(i)+S(i+1)+S(i+2)+S(i+3)+S(i+4))/9;
    i=i+1;
end
V(637:640)=S(637:640);
figure(9);
plot(V)
%-----

D(1:4)=V(1:4);
for(i=5:636)
    D(i)=(V(i-4)+V(i-3)+V(i-2)+V(i-1)+V(i)+V(i+1)+V(i+2)+V(i+3)+V(i+4))/9;
    i=i+1;
end
D(637:640)=V(637:640);
figure(10);
plot(D)
%-----

F(1:4)=D(1:4);
for(i=5:636)
    F(i)=(D(i-4)+D(i-3)+D(i-2)+D(i-1)+D(i)+D(i+1)+D(i+2)+D(i+3)+D(i+4))/9;
    i=i+1;
end

F(637:640)=D(637:640);
figure(11);
plot(F)
%-----

G(1:5)=F(1:5);

```

```

for(i=6:635)
    G(i)=(F(i-5)+F(i-4)+F(i-3)+F(i-2)+F(i-1)+F(i)+F(i+1)+F(i+2)+F(i+3)+F(i+4)+F(i+5))/11;
    i=i+1;
end

G(636:640)=F(636:640);
figure(12);
plot(G)
%-----

J(1:5)=G(1:5);
for(i=6:635)
    J(i)=(G(i-5)+G(i-4)+G(i-3)+G(i-2)+G(i-1)+G(i)+G(i+1)+G(i+2)+G(i+3)+G(i+4)+G(i+5))/11;
    i=i+1;
end

J(636:640)=G(636:640);
figure(13);
plot(J)
%-----

M(1:5)=G(1:5);

for(i=6:635)
    M(i)=(J(i-5)+J(i-4)+J(i-3)+J(i-2)+J(i-1)+J(i)+J(i+1)+J(i+2)+J(i+3)+J(i+4)+J(i+5))/11;
    i=i+1;
end

M(636:640)=J(636:640);
figure(14);
plot(M)

%int16 for å få negativt fortegn
K= int16(U);
N= int16(M);
G=K-N;
plot(G);
%Utregning av kontrast.
STD=std(G)
%neste trinn er å fjerne de ytterste samplene for å forhindre at det
%spolerer kontrastmålingen.
C=STD/(mean(U))

```

A.1.2 Code for finding the middle of the picture

```
function []=finnemidtrad()

I=imread('tiende/test1.bmp');
qmax=0;
istor=0;
for(i=1:480);
    N(1:640)=I(i,1:640);
    k=mean(N);
    if k>qmax
        W(1:640)=N;
        qmax=k;
        istor=i;
    end
    i=i+1;
end
qmax
istor
plot(W)
```

A.2 Datasheets

A.2.1 Mini- Shaker type 4810

type 4810

Mini-Shaker

FEATURES:

- Force rating 10 Newton (2,25 lbf) Sine Peak
- Frequency range DC to 18 kHz
- First axial resonance above 18 kHz
- Max. bare table acceleration 550 ms^{-2} (56 g)
- Rugged construction

USES:

- Calibration of accelerometers
- Vibration testing of small objects
- Educational demonstrations
- Mechanical impedance measurements

The Mini-Shaker Type 4810 is a small machine for the dynamic excitation of lighter objects, it is manufactured from quality materials to a high degree of precision and has proved to be a reliable and versatile tool in dynamic testing.

Type 4810 is well suited as the motive force generator in mechanical impedance measurements where only smaller forces are required.

It can also be used in the calibration of vibration transducers, both to determine their sensitivity by comparison with a standard accelerometer, and to determine their frequency response up to 18 kHz.

The Mini-Shaker is of the electrodynamic type with a permanent field magnet. A coil, which is an integral part of the table structure, is flexibly suspended in one plane in the

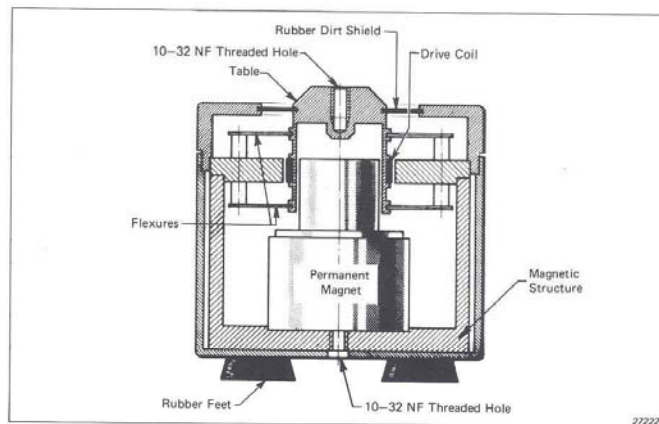

Fig. 1. Sectional drawing of the Mini-Shaker Type 4810

field of the permanent magnet. An alternating current signal, provided by an external oscillator is passed through the coil to produce a vibratory motion at the table. A sectional drawing illustrating the method of construction is shown in Fig. 1.

The suspension system consists of radial flexure springs which restrict the moving element to almost perfectly rectilinear motion. Laminated flexure springs provide a high degree of damping to minimize distortion due to flexure resonances. The frequency response curves

shown in Fig.2 show the highly damped flexure resonance around 50 to 60 Hz.

The object to be vibrated is attached to the table by means of a 10 — 32 NF screw; the thread size commonly used for mounting accelerometers. Performance limits which are defined by the maximum displacement (6 mm), maximum force (10 N or 7 N depending on frequency), and the first axial resonance of the moving element (above 18 kHz), are graphically shown in Fig.3.

Within these limits, the attainable acceleration can be determined by the expression.

$$a = \frac{F}{W}$$

where a = acceleration in ms^{-2} ($1 ms^{-2} = 0,102 g$)
 F = shaker rated force in Newtons
 W = exciter moving element weight + test object weight in kg

Examples of maximum test object weight for accelerations of 20 g and 5 g are drawn in on the curve.

In order to attain full rated output force from the 4810 it should be driven by Power Amplifier Type 2706. This is a power amplifier specially designed to drive small vibra-

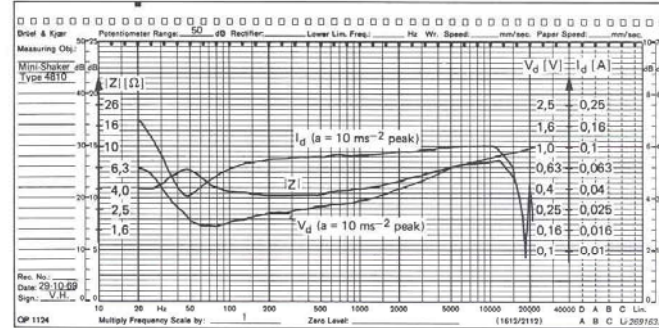

Fig.2. Frequency response of the 4810 for Impedance (Z), current (I) and voltage (V)

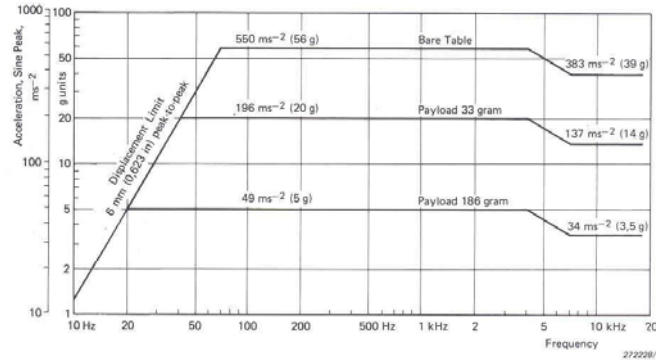

Fig.3. Sine performance curves for the 4810

tion exciters and has a current limiter to prevent overdriving the 4810. The Mini-Shaker can also be driven at a lower level by Sine Generator

Type 1023. This has an output of 7,0W which will drive the Mini-Shaker to a rated force of approximately 3,9 N (0,9 lbf) peak.

Specifications 4810

Frequency Range: DC to 18 kHz	Dynamic Flexure Stiffness: 2 Newton/mm (11,5 lbs./in)	Table Size: 14 mm (0,55 in) diameter
First Major Armature Resonance: Above 18 kHz	Dynamic Weight of the Moving System: 18 grams	Fastening Thread: NF 10 — 32
Force Rating (Peak): 10 Newton (2,25 lbf). 65 Hz to 4 kHz 7 Newton (1,5 lbf). 65 Hz to 18 kHz	Magnetic Field: Permanent magnet	Weight: 1,1 kg (2,4 lb)
Max. Bare Table Acceleration (Peak): 550 ms^{-2} (65 Hz to 4 kHz) 383 ms^{-2} (4 kHz to 18 kHz) (1 $ms^{-2} = 0,102 g$)	Max. Input Current: 1,8 A. RMS	Dimensions: Diameter: 76 mm (3 in) Height: 75 mm (2,9 in)
Max. Displacement (Peak-to-Peak): 6 mm (0,236 in)	Coil Impedance: 3,5 Ω at 500 Hz	Accessories Available: Cable for connection of Mini-Shaker to Power Amplifier AO 0069 Mounting Accessories (includes isolated studs YP 0150 and non-isolated studs YQ 2960) UA 0125
	Connection: Microsocket NF 10 — 32	

2. OPERATION

2.1. MOUNTING THE 4810

For accelerometer calibration and testing of small test objects the 4810 can be used in an upright position, standing on its three rubber feet. If a more secure mounting arrangement is required, it may be fastened to a workbench via the 10 - 32 NF threaded hole at the centre of its base or the 3 mm screws fastening its three rubber feet may be used.

2.2. MOUNTING TEST OBJECTS

The vibration table of the 4810 is provided with a single fixing hole. This has a 10 - 32 NF reinforced helical steel thread and is $10 \pm 0,1$ mm ($0,4 \pm 0,004$ in) deep. For fixing accelerometers and vibration test objects to the table the 10 - 32 NF steel mounting studs YQ 2960 and isolated mounting studs YP 0150 are available. The correct mounting torque is 1,76 Nm (15 lb in).

To prevent damage to the 4810 always use a torque wrench for fixing accelerometers and test objects onto the table and ensure that the mounting stud does not bottom in the fixing hole. Also ensure that the test object is mounted with its centre of gravity in line with the centre of the vibration table, as otherwise unbalanced loads may cause the table drive coil to rub against the pole piece of the 4810.

When a test object is mounted directly on the vibration table it will exert a force on the table creating a static displacement. If this is found to be too large the test object may be suspended in resilient straps, so that its full mass does not bear directly on the table.

2.3. CONNECTION OF POWER AMPLIFIER

The range of B & K Exciter Control Generators and Power Amplifiers which may be used with the 4810 are shown in Fig.2.1.

The 4810 can be powered directly from the LOAD OUTPUT socket of Sine Generator Type 1023. The maximum output is 7W which will drive the 4810 to a rated force of approximately 3,9 N (0,9 lbf) peak. For full rated output force of 10 N (2,25 lbf) a Power Amplifier Type 2706 should be included in the set-up. This is specially designed to drive small vibration exciters and has a current limiter to prevent overdriving the 4810 (CAUTION: The current limiter on the 2706 has 2 settings and care must be taken to choose the 1,8A setting. The Mini-Shaker may otherwise be overdriven and ultimately damaged).

Connection of the POWER INPUT socket of the 4810 to the 1023 Sine Generator or the 2706 Power Amplifier can be made using a B & K cable AO 0069 with a Miniature Coaxial Plug in one end and a twin banana plug in the other.

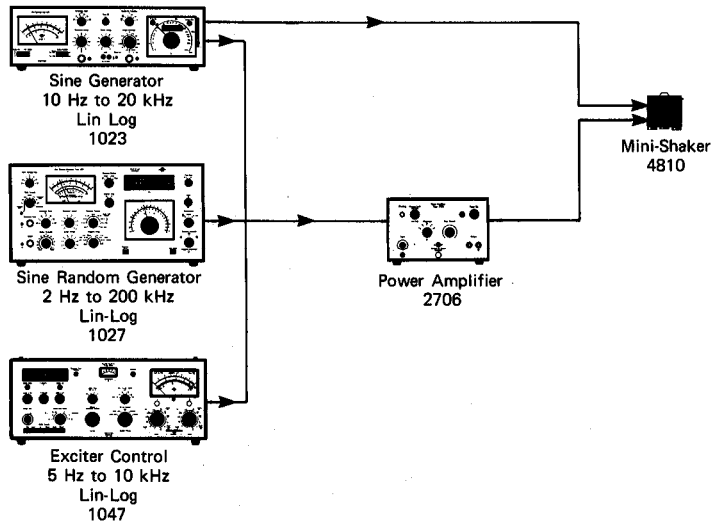

780832

Fig.2.1. B & K Exciter Control Generators and Power Amplifiers for use with the 4810 Mini-Shaker.

A.2.2 Pre-amplifier type 2626

type 2626

Conditioning Amplifier

FEATURES:

- Charge input
- 3 digit conditioning to transducer sensitivity
- Unified output ratings for simplified system calibration
- High sensitivity up to 1000 mV/pC
- Direct and Transformer coupled output modes
- Switchable low and high frequency limits

USES:

- General purpose vibration measurements with piezoelectric accelerometers
- Signal conditioning in vibration test control set-ups
- Multi-purpose signal conditioning amplifier for piezoelectric transducers
- Comparison calibration of piezoelectric transducers

Conditioning Amplifier Type 2626 is a low noise charge amplifier for use with piezoelectric accelerometers and other piezoelectric measurement transducers. It enables long transducer connection cables to be used without affecting the charge sensitivity of transducers and offers a wide range of signal

conditioning facilities that make it ideal for use with accelerometers in calibration set-ups, as well as in set-ups for general purpose vibration measurements.

A block diagram of the 2626 is shown in Fig.1. The amplifier features precision conditioning networks for 3 digit dial-in on the Amplifier of exact transducer charge sensitivities ranging from 1,0 to 1099 pC/measurement unit. These condition the sensitivity of the transducer and Amplifier combination giving *unified output ratings from 0,001 to 10 V/measurement unit*, which may be selected in accurate decade steps. This feature greatly simplifies the calibration and reading of a measuring system, especially when using transducers which have "odd" sensitivity values, i.e. non Uni-Gain types. With transducers having a source capacitance of 1 nF the maximum overall gain of the Amplifier is 60 dB.

For suppression of noise and other spurious signals, the 2626 has adjustable high and low pass filters built-in. These may be used to limit the basic 0,3 Hz to 100 kHz (–3 dB) frequency range of the Amplifier and are active filters with attenuation slopes of 20 and 40 dB/decade respectively. The filter switch positions marked on the front panel give the 5% as well as 3 dB frequency limits.

In addition to the standard B & K miniature input and output sockets on the front panel, there is an alternative miniature input socket and

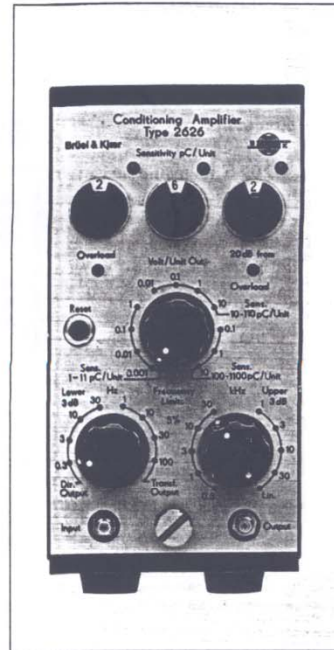

BNC output socket on the rear of the 2626. "Direct" as well as "Transformer" coupled output modes may be selected, the latter being of particular benefit in prevention of signal ground loops and when using the 2626 in the feedback loop of vibration exciter control systems. The "20 dB from Overload" and "Overload" signal level indicator lamps which are connected to the outputs, help in selecting a

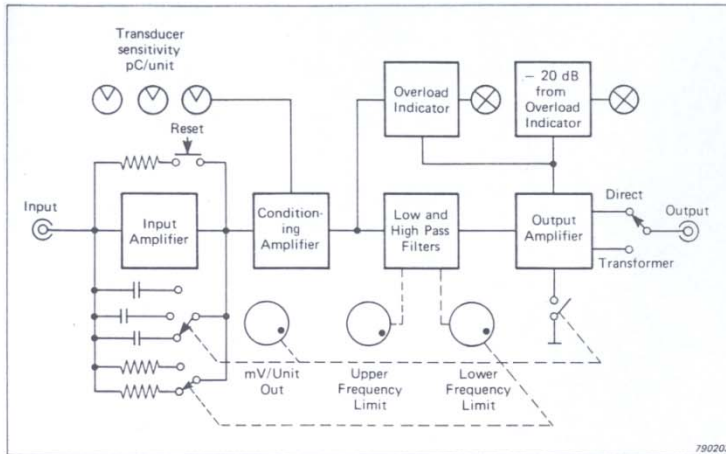

Fig.1. Block diagram of Type 2626

unified output rating that gives optimum signal to noise ratio for measurements. Power for the 2626 may be provided from any 100 to 240 V AC mains supply.

Type 2626 is available separately

or, for use in piezoelectric accelerometer calibration set-ups, can be obtained in the calibration Set Type 3506 which also includes a B & K Reference Accelerometer Type 8305. See B & K Short and Main Catalogues for details.

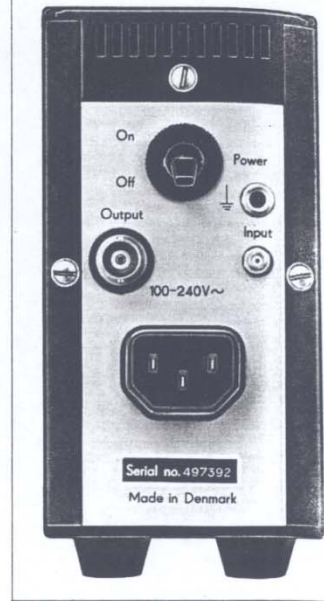

Fig.2. Rear Panel of Type 2626

Specifications 2626

<p>CHARGE INPUT: Via 10-32 NF miniature coaxial socket Max. Input: $\sim 10^5$ pC</p> <p>SENSITIVITY CONDITIONING: 3 digit dial-in of transducer sensitivity from 1,0 to 1099 pC/unit</p>	<p>DC Offset: ± 10 mV max. Output Impedance: $< 1 \Omega$ at frequencies up to 10 kHz for all V/UNIT OUT settings except the highest in each transducer range where it is $< 10 \Omega$</p>	<p>LEVEL INDICATORS "Overload" LED lights when input or output level exceeds 10 V peak "20 dB from Overload" LED lights when output level is between 1 and 10 V peak</p>
<p>AMPLIFIER SENSITIVITY: 0,1 to 1000 mV/pC corresponding to -20 to +60 dB with transducer capacitance of 1 nF</p> <p>CALIBRATED OUTPUT RATINGS: 0,001 to 10 V/unit selectable in 20 dB steps</p>	<p>"Transformer": Max. Output: 10 V (10 mA) peak from 40 Hz to 30 kHz. Below 40 Hz the output voltage is reduced by 20 dB/decade so that at 1 Hz it is 0,2 V peak DC Offset: zero Output Impedance: 12Ω for all V/UNIT OUT settings except the highest in each transducer range where it is 22Ω</p>	<p>RISE TIME: $\sim 2,5$ V/μs RECOVERY TIME: $< 200 \mu$s</p>
<p>ACCURACY: For two lower V/UNIT OUT settings of each transducer range: $\pm 0,5\%$ at 1 kHz increasing to $\pm 1\%$ at 10 kHz for input loads less than 60 nF and 20 nF respectively. 1% change in gain for input loads of ~ 200nF and ~ 100 nF respectively For other V/UNIT OUT settings: $\pm 1\%$ at 1 kHz increasing to $\pm 2\%$ at 10 kHz for input loads less than 6 nF. 1% change in gain for input loads of ~ 15 nF</p>	<p>FREQUENCY RANGE: 0,3 Hz to 100 kHz</p>	<p>ENVIRONMENTAL CONDITIONS: Temperature Range: -10 to $+55^\circ\text{C}$ ($+14$ to 131°F) Humidity: 0 to 90% RH (non-condensing). For use in high humidities a 3 W heater may be fitted on special order</p>
<p>SIGNAL OUTPUT: Choice of "Direct" and "Transformer" coupled outputs via 10-32 NF and BNC coaxial socket "Direct": Max. Output: 10 V (10 mA) peak from 0,3 Hz to 30 kHz</p>	<p>LOW-PASS FILTER: Switchable -3 dB upper frequency limits of 1 kHz, 3 kHz, 10 kHz, 30 kHz and Lin ~ 100 kHz with attenuation slope of 40 dB/decade</p>	<p>POWER REQUIREMENTS: 100 to 240 V (50 to 400 Hz) $\pm 10\%$ AC. 7 VA. Complies with Safety Class I of IEC 348</p>
	<p>HIGH-PASS FILTER: Switchable -3 dB lower frequency limits of 0,3 Hz, 1 Hz, 3 Hz, 10 Hz and 30 Hz with attenuation slope of 20 dB/decade</p>	<p>DIMENSIONS: Height: 132,6 mm (5,22 in) Width: 69,5 mm (2,74 in) Depth: 200 mm (7,87 in) B & K module cassette KK 0022, 2/12 of 19 in rack module</p>
	<p>DISTORTION: $< 1\%$ INHERENT NOISE (2 Hz to 22 kHz) $5 \cdot 10^{-3}$ pC referred to input with maximum sensitivity and 1 nF transducer capacitance</p>	<p>WEIGHT: 1,75 kg (3,89 lb) ACCESSORIES INCLUDED: 1 x Power Cable AN 0010 1 x 50 mA Fuse VF 0016</p>

Conditioning Amplifier Type 2626

SPECIFIC FEATURES

- 3 digit conditioning to transducer sensitivity
- Direct indication of system sensitivity in V/g
- High sensitivity up to 1V/pC
- Switchable High pass and Low pass filters
- Signal level indicator lamps
- Output direct coupled with negligible DC off-set or transformer coupled floating
- Fast recovery
- Low noise

USES

- Vibration measurements with long cables between transducer and preamplifier
- General purpose vibration measurements
- Signal conditioning in vibration-test servo loops

The Conditioning Amplifier Type 2626 is a charge preamplifier offering comprehensive signal conditioning facilities together with a very high signal to noise ratio which make it an ideal general purpose vibration pre-amplifier for use with piezoelectric transducers. The amplifier features a 3 digit sensitivity adjustment network which enables the amplifier sensitivity to be conditioned to suit transducer sensitivities between 1 and 1100 pC/g. This feature greatly simplifies the calibration and reading of a measuring system, especially when using transducers which have "odd" sensitivity values, ie. non Uni-Gain® types.

The amplifier has a rated output switchable in decades between 1 mV/g and 10 V/g depending on the sensitivity of the transducer. The maximum gain is 60 dB with a source capacitance of 1 nF. Adjustable High-pass and Low-pass filters are provided to enable the pass band of the instrument to be limited to the frequency range of interest, thus reducing the influence of noise and spurious signals outside this

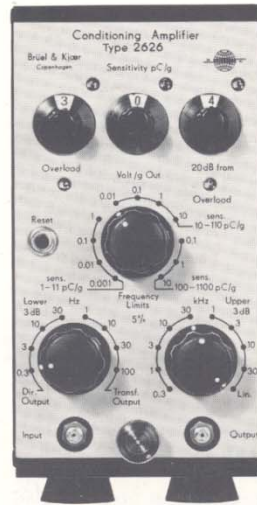

band. The filter switch positions marked on the front panel give the 5% as well as the 3 dB frequency limits.

Fig.13 shows the block diagram of the 2626. The signal from the transducer is fed to the input section which contains an amplifier stage with capacitive feedback forming a charge amplifier. The signal goes on to the conditioning section where the sensitivity is adjusted to match the transducer and further to a Low-pass filter (2 pole Butterworth) and a High-pass filter (single pole) where the upper and lower frequency limits of the amplifier are determined.

From the filters the signal is fed to an output amplifier and further to the output. The signal is available either directly coupled or through a trans-

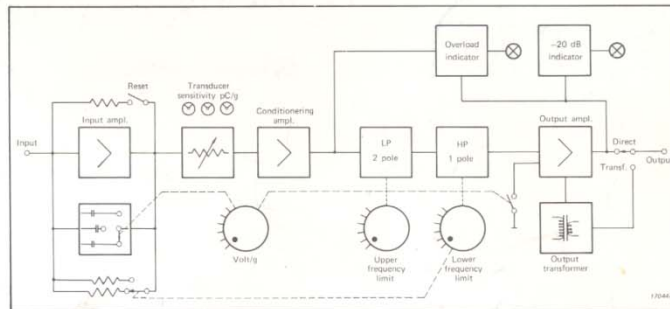

Fig.13. Block diagram of Type 2626

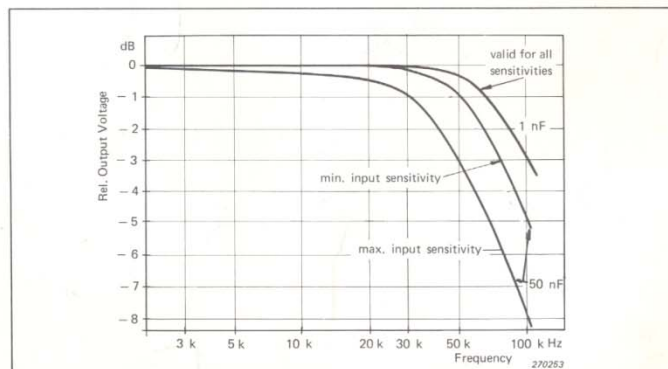

Fig.14. High frequency response of Type 2626 with different capacitive input loads for maximum and minimum amplifier sensitivity. A 50 nF load is equivalent to an output cable length of 550 m (1800 ft)

A.2.3 Diode Pumped Solid State Laser

NEW

Specifications

Wavelength	532 nm
Output power, max.	4 mW
Output power stability	< 5 % after warm-up at 25 °C
Beam divergence	< = 1 mRad
Output beam diameter	approx. 1 mm
Beam angle error	≤ 1 °C
Operating mode	cw
Mode	TEM ₀₀
Modulation frequency, max.	approx. 20 kHz
Life time typ.	3000 hrs
Input voltage	3 – 6 VDC (internal voltage stabilization) Optional 8 – 30 VDC
Operating current	100 – 300 mA
Fail safe mode	In cases of power or current surges the module shuts down until power is completely switched off and turned back on
Connection	Cable: brown +ve, white earth, green modulation
Operating temperature	20 – 30 °C
Storage temperature	-10 to +60 °C
Mechanical	length = 57 mm, Ø 11,5 mm (l = 67 mm with option 8 – 30 VDC)
Housing material	anodised aluminium, potential free

Improved safety through second control circuit.

We recommend to use a low input voltage to reduce power consumption and heat.

To ensure the maximum lifetime of the laser module, please use a suitable heat sink.

All specifications subject to change without notice.

www.lasercomponents.com

Germany and other countries: LASER COMPONENTS GmbH, Phone: +49 8142 2864-0, Fax: +49 8142 2864-11, info@lasercomponents.com

USA: LASER COMPONENTS IG, Inc., Phone: +1 603 821 7040, Fax: +1 603 821 7041, info@laser-components.com

Great Britain: LASER COMPONENTS (UK) Ltd., Phone: + 44 1245 491 499, Fax: +44 1245 491 801, info@lasercomponents.co.uk

France: OPTOPHOTONICS sa, Phone: + 33 (0)1 3959 5225, Fax: +33 (0)1 3959 5350, info@optophotonics.fr

Issue: 12/04 / V5 / IF / Datenblätter / Blau-db / Grüner Flexpoint engl.doc



DPSS green laser diode module 532nm

Key features

- Visible light $\lambda = 532\text{nm}$
- Output power 0.9mW and 4mW
- Circular beam 1.2mm typ.
- Adjustable lens
- Modulation 0-1kHz
- Compact and self-contained
- High reliability

Applications

- Industrial alignment
- Medical alignment
- Scientific equipment

data

532nm DPSS Green Laser Diode Module

The 300-0088 series DPSS green laser diode module offers a circular output beam of 1.2mm diameter with beam divergence of $<2.0\text{mrad}$, output power of 0.9mW or 4mW, an operating voltage of 4-6V at an operating current of 350mA maximum, and operating temperature from $+10^{\circ}\text{C}$ to $+30^{\circ}\text{C}$. Power stability is better than 5% over 7 hours.

The DPSS (Diode Pumped Solid State) laser diode module has been designed as a complete laser diode solution for OEM use.

It consists of an anodised aluminium housing, laser diode, drive circuit and user-adjustable collimating lens. Electrical connections are made via external flying leads.

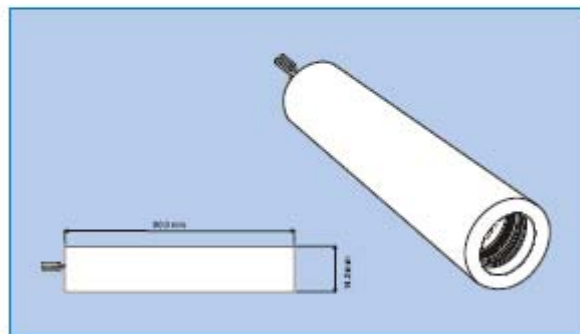

laser diode solutions

DPSS green laser diode module 532nm

Specifications (Tc=25°C)

ITEM / PART no.	300-0088-00	300-0088-01
Wavelength	532nm	532nm
Output Power (at 10%)	0.9mW	4.0mW
Beam Size (typ 1/e ²)	1.2 mm	1.2 mm
Beam Circularity	≤ 1.3:1	≤ 1.3:1
Beam Divergence	≤ 2.0 mrad	≤ 2.0 mrad
Warm up Time	4-5 minutes	4-5 minutes
Power Stability (over 7 hours after warm up at constant temperature)	< 5%	< 5%
Power Stability (over operating temperature range)	≤ 20%	≤ 20%
Mode	TEM ₀₀	TEM ₀₀
Operating Voltage	4-6V DC	4-6V DC
Operating Current (25°C)	< 300mA	< 350mA
Operating Temperature (ambient)	+10°C to +30°C	+10°C to +30°C
Storage Temperature	-40°C to +60°C	-40°C to +60°C
Housing Material	Anodised Aluminium	Anodised Aluminium
Weight	40g	40g
Lifetime MTTF (typ)	5000 hours	5000 hours
Modulation	0 to 1kHz, 5V-ON, 0V-OFF 0 to 1kHz, 5V-ON, 0V-OFF	
Mechanical	14mm ± 0.1mm diameter, 60mm length (55mm including rear cable strain relief)	

Heat Sinking

If the case temperature of the laser diode exceeds its maximum specification, premature or catastrophic failure may occur. To ensure the maximum life of the laser diode, it is recommended that an additional electrically insulated heatsink of at least 50 sq cm be used. Thermal transfer cream can be used to improve contact and heat dissipation. Do not restrict air circulation around the device.

Power Connections

These DPSS laser diode modules require a regulated input voltage of 4-6V. Connections are made via the 3 pre-tinned external flying leads, (red is positive, black is negative, yellow is modulation).

WARNING: The housing is internally connected to the positive supply rail. Damage to the external anodised surfaces will result in the housing being at positive potential.

Specifications subject to change without notice. EAOE



Laser Safety

The light emitted from these devices has been set in accordance with IEC60825. However, staring into the beam, whether directly or indirectly, must be avoided. IEC60825 classifies laser products into three different categories depending on light emitted, wavelength and eye safety.

CLASS II

"Caution", visible laser light less than 1.0mW. Considered eye safe, normal exposure to this type of beam will not cause permanent damage to the retina.

CLASS IIIA

"Danger", visible laser light between 1.0mW and 5.0mW. Considered eye safe with caution. Focusing of this light into the eye could cause some damage.

CLASS IIIB

"Danger", Infrared (IR), and high power visible lasers considered dangerous to the retina if exposed.

NE: It is important to note that while complying with the above classifications, unless otherwise stated, our laser diode products are not certified and are designed solely for use in OEM products. The way in which the device is used in the final product may alter its original design classification, and it is the responsibility of the OEM to ensure compliance with the relevant standards.

PHOTONIC PRODUCTS UK LIMITED

Pierce Williams, Sparrow Lane
Hatfield Broad Oak, Hertfordshire CM22 7BA, UK
Telephone: +44 (0) 1279 717170
Facsimile: +44 (0) 1279 717171
E-mail: sales@photonic-products.com
www.photonic-products.com

PHOTONIC PRODUCTS USA

Telephone: +1 714-841-1960
E-mail: salesusa@photonic-products.com

PHOTONIC PRODUCTS GERMANY

Telefon: +49 (0) 8142 / 669 8364
E-mail: salesgermany@photonic-products.com
www.photonic-products.com

2.2.4 Lumenera industrial monochromatic camera



Lumenera
corporation

Lu070

VGA USB 2.0 Camera



Outline

Lumenera's Lu070 series of cameras are designed to be used in a wide variety of industrial applications, particularly in low light conditions. Both color and monochrome product models are available.

With 640x480 resolution and on-board processing these cameras deliver outstanding image quality and value for industrial and scientific imaging applications.

Electronic Global Shutter provides capabilities similar to a mechanical shutter, allowing simultaneous integration of the entire pixel array, and then stopping exposure while image data is read out. Ideal for capturing objects in high-speed motion.

Uncompressed images in live streaming video and still image capture are provided across a USB 2.0 digital interface. No framegrabber is required. Advanced camera control is available through a complete Software Developer's Kit, with sample code available to quickly integrate camera functions into OEM applications.

Hardware and software based synchronization trigger is provided standard. On-board memory is available for frame buffering. Lu070 series cameras are offered in both enclosed and board-level form. Custom form factor (sizes) can be provided.

All Lumenera products are supported by an experienced team of software developers and application engineers. We understand your imaging needs and are here to help you with your integration and development. Products come with a full one (1) year warranty.

Performance Features

- ❑ Global electronic shutter
- ❑ Excellent sensitivity
- ❑ High speed USB 2.0 (480Mbits/sec)
- ❑ Color or monochrome, interline, progressive scan, 640x480 resolution
- ❑ 60 fps at full 640x480
+100 fps 320x240 (binning mode)
- ❑ Auto white balance & s/w adjustable exposure
- ❑ On-board image buffer
- ❑ GPIOs for control of peripherals and synchronization of lighting (4in/4out)
- ❑ FCC Class B, CE Ready
- ❑ Select 8 or 12-bit pixel data
- ❑ Simplified cabling - video, power and full camera control over a single USB cable
- ❑ DirectShow compatible
- ❑ C-Mount provided
- ❑ USB cameras are software compatible with Windows™ 98 SE, Windows ME, Windows 2K and Windows XP operating systems
- ❑ Complete SDK available

Specifications

Lu070

Image Sensor	1/3" format, 5.8mm x 4.9mm array
Effective Pixels	640 x 480, 7.4um square pixels
Frame Rate	60 fps at 640x480, 100+ fps 320x240 (binning)
Sensitivity	High
Dynamic Range	60dB
Exposure	Auto / Manual
White Balance	Auto / Manual
Dimensions (W x H x D)	2.00 x 2.50 x 1.63 inches (board level) 2.25 x 3.85 x 1.56 inches (enclosed)
Mass	~150g / 300g with enclosure
Power Requirement	USB bus power, or external 6VDC, 700mA
Power Consumption	~4 Watts
Operating Temperature	0°C to +50°C
Operating Humidity	0% - 95%, Non-condensing
Interface Connector	Standard USB cable
Lens Mount (Lens not included)	C-Mount, (CS-Mount option)

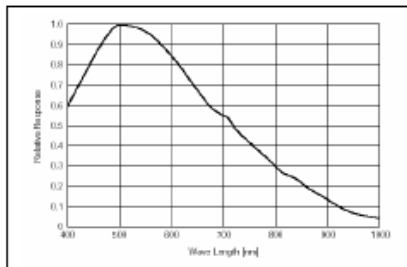

Monochrome Response

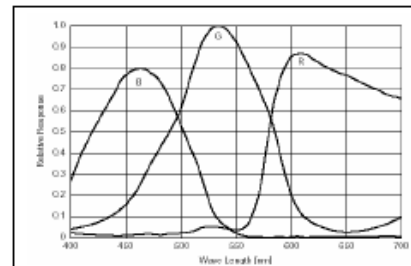

Color Response

***Full customization
available to meet your
exact needs!***

Ordering Information

Lu070M	– Monochrome Camera Module
Lu070C	– Color Camera Module
Lu075M	– Enclosed Monochrome Camera
Lu075C	– Enclosed Color Camera
LuSDK	– Software Developer's Kit

Mechanicals

Lu070

OEM Board-Level Camera

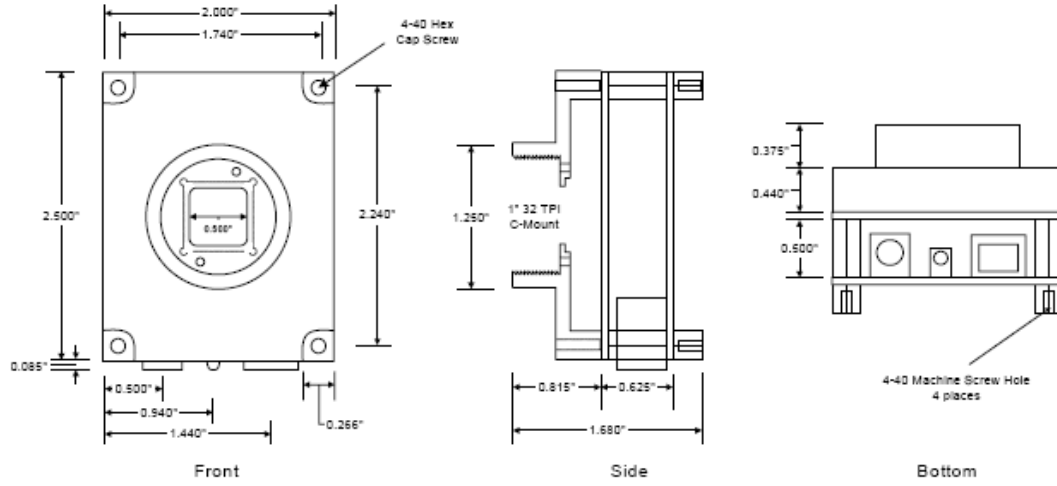

Enclosed Camera

