



NTNU – Trondheim
Norwegian University of
Science and Technology

Steps towards chemo-enzymatic synthesis of enantiomerically pure Levosalbutamol

Erik Våland Tveit

Chemistry

Submission date: August 2015

Supervisor: Elisabeth Egholm Jacobsen, IKJ

Norwegian University of Science and Technology
Department of Chemistry

I hereby declare that this Master's thesis is an independent work in accordance with the rules and regulations set by the Norwegian University of Science and Technology.

Trondheim, 15.August 2015

Erik Våland Tveit

Foreword

This Master's Thesis, "Steps towards chemo-enzymatic synthesis of enantiomerically pure levosalbutamol", has been written as a part of the study programme Master in Organic Chemistry at the Institute of Chemistry at the Norwegian University of Science and Technology, under the supervision of Elisabeth Egholm Jacobsen. The work for this thesis was done between August 2013 and August 2015.

I would like to thank Elisabeth for her academic support, as well as her interest, insight and patience during these two years. In a period of both academic and personal growth, she has shown unconditionally support which I consider invaluable and will be forever grateful for. Furthermore, I would like to thank Ingvild Teigen Lund, Sigve Eliassen and Pål Bøckmann for their companionship and feedback in the laboratory. Another thanks to Camilla Skjærpe for providing the foundation my work has been based on.

Thanks to Silje Henriksen and Sigrid Løvland for valuable contributions to this thesis during their project in the organic synthesis course. Thanks to Roger Aarvik, Merethe Vadseth, Susanna Gonzales, Rudolf Schmidt, Julie Asmussen and Torunn Melø for their technical support during these years.

Thanks to my family and friends for their interest in my progress and for lending me a listening ear. Thanks to Tærje Alm for being the proverbial rubber duck when I needed to air my thoughts and ideas, and thanks to Marius Bakken for sparking my interest in chemistry and directing me down this path 8 years ago.

Lastly, I would like to extend my deepest gratitude to Vilde Elisabet Rausch for being there for me as emotional and structural support.

Thesis goal

The aim of this thesis was to explore the possibilities of synthesizing the pure enantiomer of salbutamol, namely levosalbutamol, using pure enzymes or whole organisms in the chiral steps in the synthesis. The intention of this was to find a cost effective synthetic route in order to avoid using expensive and hazardous metal catalysts and reduce the amount of waste produced during the synthesis.

Abstract

Asthma is one of the most common non-communicable diseases in the world, affecting almost 4 % of the world's population. The cause behind asthma is not understood, but it is believed to be a combination of genetic predisposition and environmental factors. This is a condition that is affecting more and more people, especially in developing countries, where medication is less available. There are many different treatments to manage this chronic inflammation of the airways; β_2 adrenergic receptor agonists, corticosteroids or synthetic antibodies, but during an acute asthma attack the short-acting β_2 adrenergic receptor agonists (SABAs) are the most effective. The most commonly used SABA is marketed under the name Ventoline, with the active compound being a racemic mixture of salbutamol. It is commonly known that salbutamol has one active enantiomer and one inactive enantiomer, but it has been debated whether the medicine with the pure active enantiomer is worth its increase in cost.

This thesis focuses on exploring the possibilities for a biocatalytic approach in the synthesis of the clinically active enantiomer, levosalbutamol, in an attempt to reduce the waste and cost of the industrial synthesis. This topic has been approached previously by Camilla Skjærpe in her master thesis, on which this thesis is based. Using her work as a foundation, the synthetic route from salicylaldehyde to levosalbutamol was evaluated, and the biocatalytic use of Baker's yeast (*Saccharomyces cerevisiae*) and *Candida antarctica* lipase A (CALA) was incorporated. The first reaction, a Friedel-Crafts acylation, gave a decent yield (34.9 %) and high purity. The second step was a reduction, where both LiAlH_4 and *S. cerevisiae* was attempted. The chemical reduction had a lot of room for improvement and the yeast reduction was promising, but the complete workup was missing. Using LiAlH_4 required enzymatic resolution with CALA, which yielded very poor results. The next and last step would be amination with *t*-butyl amine, but this step was not done due to time constraints combined with difficulties in the workup of the preceding step.

Sammendrag

Astma er en av de mest vanlige ikke-smittsomme sykdommene i verden og påvirker nesten 4 % av verdens befolkning. Hva som forårsaker astma er ikke kjent, men det mistenkes å være en kombinasjon av genetiske forutsetninger og miljø. Dette er en tilstand som påvirker flere og flere folk, spesielt i utviklingsland, hvor medisin ofte er mindre tilgjengelig. Det finnes mange måter å håndtere denne kroniske betennelsen i luftveiene; β_2 adrenergiske reseptor agonister, kortison og steroider, eller syntetiske antistoffer, men ved et akutt astmaanfall så er det de korttidsvirkende β_2 adrenergiske reseptorene (anfallsmedisin) som er mest effektive. Den vanligste anfallsmedisinen er markedsført som Ventoline, hvor virkestoffet er en rasemisk blanding av salbutamol. Det er godt kjent at salbutamol har en aktiv enantiomer og en inaktiv enantiomer, men det er omstridt hvorvidt medisinen med kun den aktive enantiomeren er verdt den ekstra kostnaden.

Denne oppgaven fokuserer på å utforske mulighetene til å ha en biokatalytisk tilnærming til syntesen av den aktive enantiomeren, levosalbutamol, i et forsøk på å redusere avfall og utgifter i den industrielle syntesen. Dette emnet har blitt utforsket tidligere av Camilla Skjærpe i hennes masteroppgave, som denne oppgaven er basert på. Ved å bruke hennes arbeid som fundament ble reaksjonsforløpet fra salicylaldehyd til levosalbutamol evaluert og biokatalytisk bruk av gjær (*Saccharomyces cerevisiae*) og *Candida antarctica* lipase A (CALA) ble benyttet. Den første reaksjonen, en Friedel-Crafts acylering, ga et moderat utbytte (34.9 %) med høy renhet. Det andre trinnet var en reduksjon, hvor både LiAlH_4 og *S. cerevisiae* ble prøvd. Den kjemiske reduksjonen hadde mye rom for forbedring og gjærreduksjonen viste lovende resultater, men full opparbeiding manglet. Ved bruk av LiAlH_4 var det nødvendig med enzymatisk oppløsning med CALA, men dette ga veldig dårlige resultater. Det neste trinnet vil være aminering med *t*-butyl amine, men dette trinnet ble ikke gjort på grunn av tidspress kombinert med problemer med opparbeidelsen i reaksjonstrinnet før.

List of relevant compounds

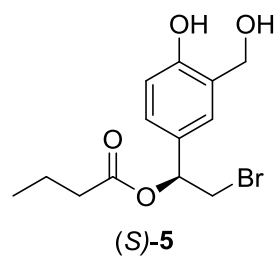
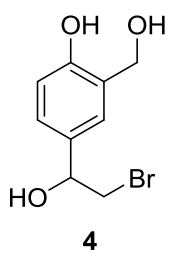
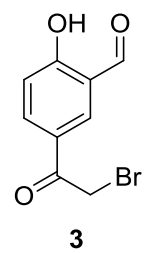
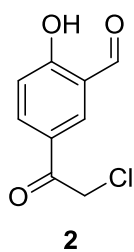
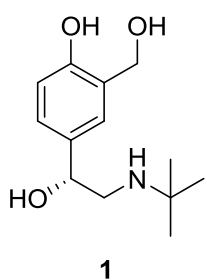

Table of Contents

FOREWORD	I
THESIS GOAL	II
ABSTRACT	III
SAMMENDRAG	IV
LIST OF RELEVANT COMPOUNDS.....	V
1 INTRODUCTION.....	1
2 THEORY.....	2
2.1 CHIRALITY	2
2.1.1 <i>The basics of chirality</i>	2
2.1.2 <i>Chiral synthesis</i>	3
2.1.3 <i>Chirality in medicine</i>	8
2.2 WHAT IS ASTHMA?	10
2.2.1 <i>Prevalence and cost</i>	10
2.2.2 <i>Physiological cause and effect</i>	12
2.2.3 <i>Medication</i>	17
2.3 SYNTHETIC ROUTE	24
2.3.1 <i>Biocatalysis</i>	26
2.3.2 <i>Current approach</i>	28
2.3.3 <i>Own approach</i>	30
2.4 ANALYTIC METHODS FOR ANALYZING CHIRAL MOLECULES.....	35
2.4.1 <i>Chiral High Performance Liquid Chromatography</i>	35
2.4.2 <i>Polarimetry</i>	37
3 RESULTS AND DISCUSSION	39
3.1 SYNTHETIC APPROACH	39
3.1.1 <i>Synthesis of 5-(2-chloroacetyl)-2-hydroxy-benzaldehyde (2)</i>	39
3.1.2 <i>Synthesis of 5-(2-bromoacetyl)-2-hydroxy-benzaldehyde (3)</i>	40
3.1.3 <i>Synthesis of 4-(2-bromo-1-hydroxyethyl)-2-(hydroxymethyl)phenol (4) with LiAlH₄</i>	44
3.1.4 <i>Enzymatic reduction of 5-(2-bromoacetyl)-2-hydroxy-benzaldehyde (4) with C. antarctica</i>	46
3.1.5 <i>Yeast reduction of 5-(2-bromoacetyl)-2-hydroxy-benzaldehyde (3) with S. cerevisiae</i>	46
3.1.6 <i>Bacterial reduction of 5-(2-bromoacetyl)-2-hydroxy-benzaldehyde (3) with L. kefir</i>	51
4 FUTURE WORK	53

5	EXPERIMENTAL SETUP	55
5.1	GENERAL.....	55
5.1.1	<i>Chemicals and solvents</i>	55
5.1.2	<i>Chromatographic analyses</i>	55
5.1.3	<i>Spectroscopic methods</i>	56
5.1.4	<i>Other analytical methods, and instruments used</i>	56
5.2	SYNTHESIS OF COMPOUNDS.....	57
5.2.1	<i>Synthesis of 5-(2-chloroacetyl)-2-hydroxy-benzaldehyde</i>	57
5.2.2	<i>Synthesis of 5-(2-bromoacetyl)-2-hydroxy-benzaldehyde</i>	57
5.2.3	<i>Synthesis of 4-(2-bromo-1-hydroxyethyl)-2-(hydroxymethyl)phenol with LiAlH₄</i>	58
5.2.4	<i>Enzymatic reduction of 5-(2-bromoacetyl)-2-hydroxy-benzaldehyde with C. antarctica</i>	58
5.2.5	<i>Yeast reduction of 5-(2-bromoacetyl)-2-hydroxy-benzaldehyde with S. cerevisiae</i>	58
5.2.6	<i>Bacterial reduction of 5-(2-bromoacetyl)-2-hydroxy-benzaldehyde with L. kefir</i>	60
6	REFERENCES	61

1 Introduction

The entire premise of this thesis has already been explored in 2003 by Camilla Skjærpe (1), but as the synthetic route proved to be particularly difficult it was considered worthwhile to revisit the research question. Since many advancements has been made within the field of biocatalytic chemistry, as can be seen in Figure 1 by the sheer increase in publications made within the field of biocatalysis, it was hoped that new experimental procedures could be explored as to successfully synthesize levosalbutamol.

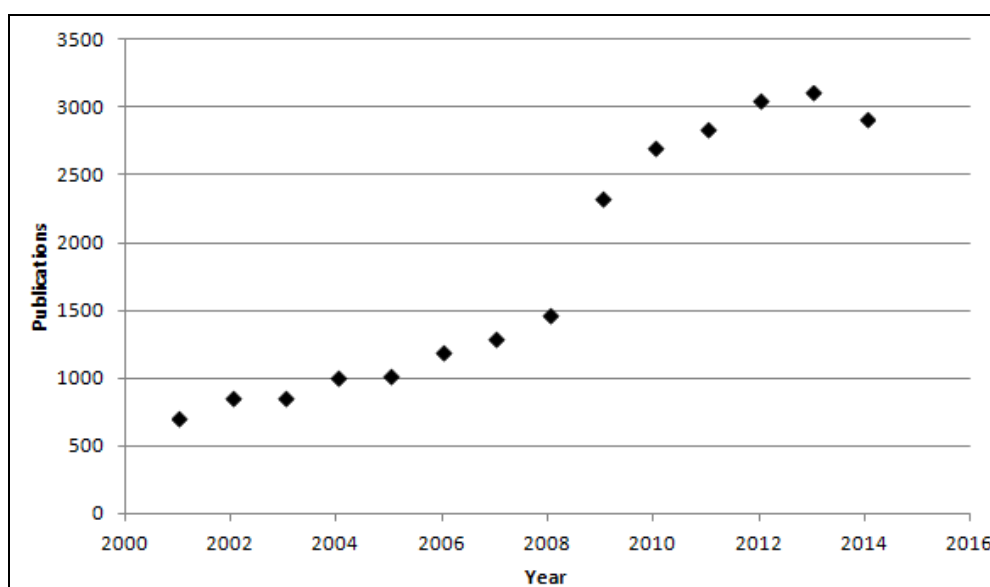
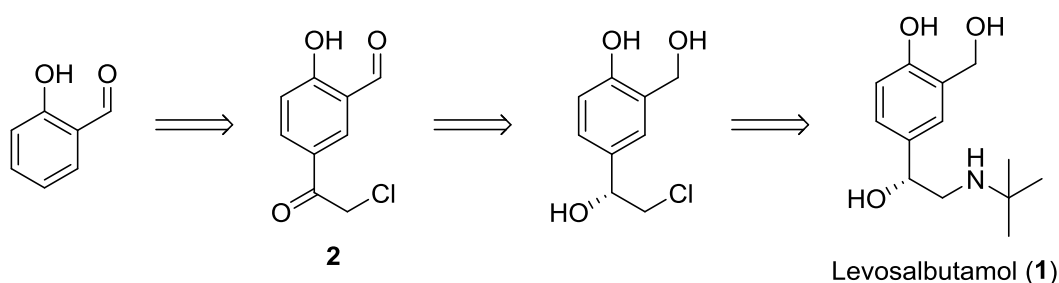

Figure 1: Published articles containing the concept of biocatalysis, as found on SciFinder. (2)

When reviewing Skjærpe's work, it seemed that the synthetic route chosen was appropriate, but some adjustments in the experimental procedure could increase yields and ultimately provide good results. Thus, the synthetic pathway chosen to be explored initially in this thesis can be seen below in Scheme 1.



Scheme 1: Planned synthetic route to synthesize enantiomerically pure levosalbutamol.

A chemical reduction of the ketone group, followed by an enzymatic resolution was also attempted. This enzymatic resolution was not attempted by Skjærpe.

Theory

2 Theory

2.1 Chirality

2.1.1 The basics of chirality

To grasp the concept of this work, understanding some basic concepts commonly known in chemistry is required. First and foremost, the idea of chirality must be understood. Simply put, chirality in terms of chemistry can be explained as asymmetric molecules. An often-used definition to describe a chiral molecule would be as a molecule of which its mirror image is not superposable on itself. Arguably, the most common way to exemplify this would be to compare your right and left hand to each other. They are mirror images of each other, but however rotated in space, they do not superpose. The word *chiral* itself is derived from Greek *cheir*, meaning hand. Nature itself is chiral and can be seen many places. The DNA is a *right-handed* helix, the heart is located on the left side and almost all naturally occurring amino acids and sugars are prevalent as just one of the mirror images. As amino acids are the building blocks for proteins, which again are the building blocks of enzymes, nature's fundamental machines, it is only natural that life itself is chiral. (3, 4)

There are several ways molecules can be asymmetric, and therefore chiral, shown in Figure 2. For example when free rotation of the chemical bonds are hindered either by double-bonds (a) or sterical interaction (b), or most commonly when the molecules contain an atom with four different substituents (c). Asymmetric molecules are called *stereoisomers*, the case of (a) and (b) are further called *diastereomers* and the molecules in (c) are called *enantiomers*. This thesis will focus on the enantiomers, where the mirror images do not superpose. Enantiomers are denoted using the Cahn-Ingold-Prelog system, where the chiral center is denoted using *R* and *S*. (3)

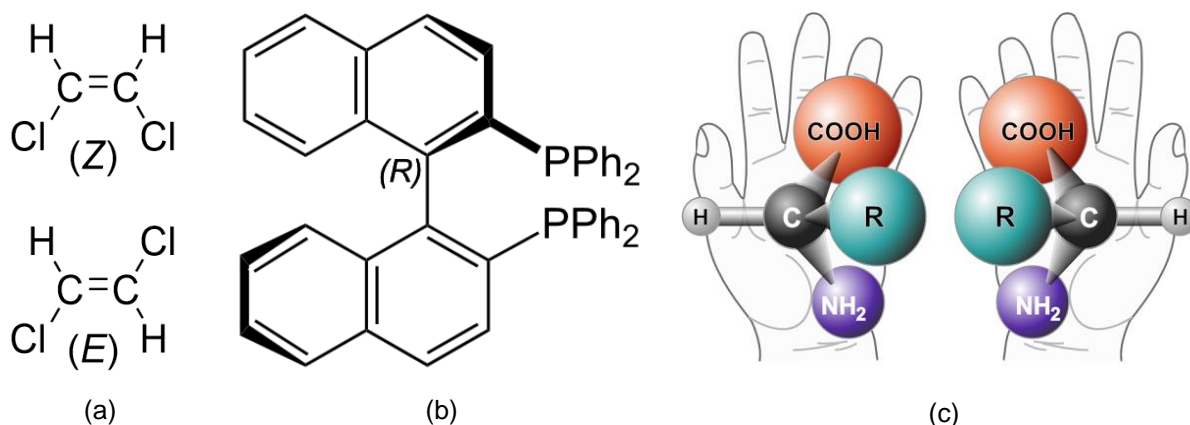

Figure 2: Diastereomers with rotation hindered by (a) double bounds, (b) steric hindrance, and (c) enantiomers with a chirality center.

It is difficult to separate or identify stereoisomers based on the traditional physical and chemical methods, as they behave similarly and almost all of their chemical and physical properties are the same. The exception to this is optical rotation, as stereoisomers will rotate a plane-polarized light in opposite directions. This will be further discussed in Section 2.4.2. In addition, isomers behave wildly different in biological settings, which is the fundamental motivation for this thesis. (3, 4)

As mentioned, nature is built using chiral building blocks, with chiral biological machines. As a result, the receptors and sensors in the body are chiral and can detect and react differently to different stereoisomers. Common examples of this would be carvone, where the *R*-enantiomer smells like spearmint and the *S*-enantiomer smells like caraway (5), and limonene, where one enantiomer is responsible for the smell in oranges and the other in lemons. (3)

2.1.2 Chiral synthesis

Broken down to its fundamentals, there are three different ways to design a synthesis with the intention of reaching an enantiomerically pure product. The three general routes are; starting with a chiral compound found naturally, synthesizing a racemate and resolving it, and using a prochiral compound as a part of an asymmetric synthesis. (6) These routes are outlined in Figure 3 below, including some of the different alternatives within each approach.

Theory

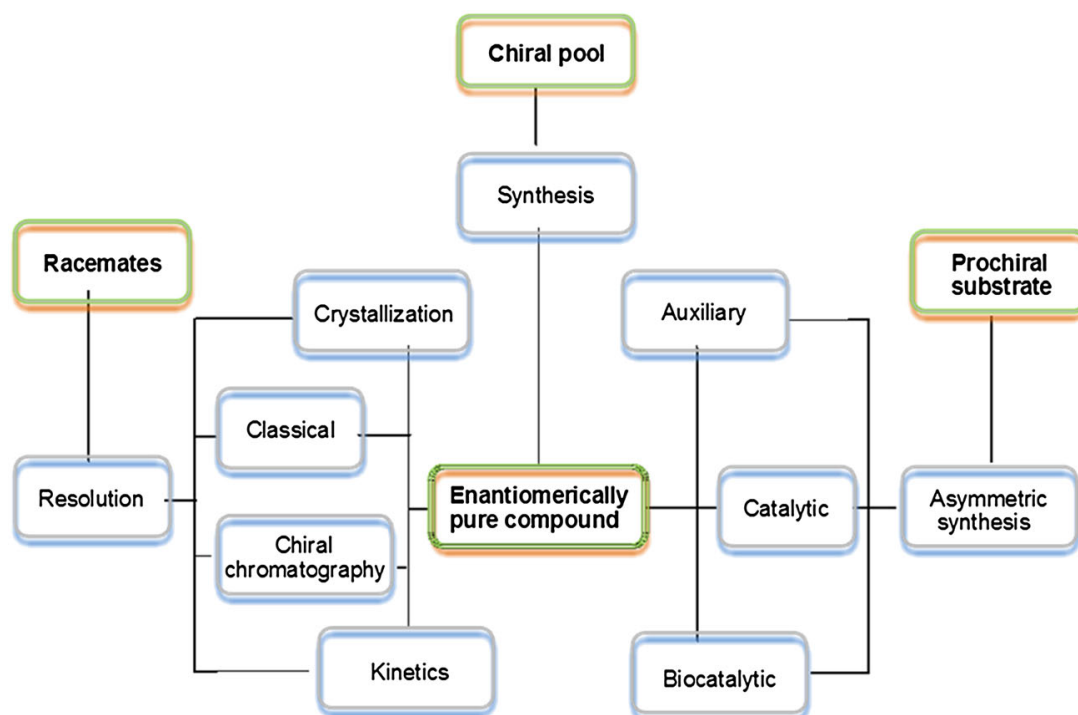

Figure 3: Different approaches to chiral synthesis. (6)

The first discovery of chiral molecules was done by Louis Pasteur in 1848 (7), when he investigated the crystal structure of tartaric acid. He compared the sodium ammonium crystals formed with a racemic mixture of tartaric salt, obtained from the owner of a chemical plant, to the crystals formed with a sample of tartaric acid, found as a natural byproduct of winemaking. He found that the racemic mixture contained two different crystal structures. One of the structures resembled the tartaric acid found in wine, while the other was an exact mirror image that was not superposable with the first crystal. He separated the two different crystals by hand and after dissolving them in water and observing them in a polarimeter, he found that they rotated the polarized light in different directions. In doing so, he resolved the enantiomers and was able to separate them, using what has become one of the most useful methods of doing so, resolution by crystallization. (3)

Allowing a racemic mixture to interact with a pure enantiomer of a resolving agent results in a diastereomer where the chiral centers of the compound and the resolving agents interact, changing their physical properties. The solubility becomes different between the two isomers, and with careful crystallization, the two stereoisomers can be separated. Assuming a good selectivity, dissolving the two sets of crystals will result in two enantiomerically pure solutions. (3, 8) As a continuation of using chiral material for racemic resolution, chiral chromatography can be used (3), which will be further explained in Section 2.4.1.

2.1 Chirality

Kinetic resolution can be done in two ways, the first being reacting the racemic mixture with a chiral catalyst where one of the enantiomers reacts faster than the other. A value used to indicate the difference in reaction rate is called the E-value and is calculated using Equation 1 below. Simply put, the E-value shows how many times faster the most reactive enantiomer reacts than the slower reacting enantiomer. (9)

$$E = \frac{\ln \frac{[ee_p(1 - ee_s)]}{(ee_p + ee_s)}}{\ln \frac{[ee_p(1 + ee_s)]}{(ee_p + ee_s)}} \quad 1$$

The ee_p and ee_s in Equation 1 stands for *enantiomeric excess* (ee). If the reaction is stopped before full conversion, the substrate will be enriched with one enantiomer, while the product will be enriched by the other enantiomer. This excess of one enantiomer is commonly called the enantiomeric excess and is calculated using the equation below. (3, 8) The ee is often used in reactions to denote the purity of the enantiomer, where 100 % ee is equal to a pure enantiomer and 0 % ee is equal to a racemic mixture.

$$ee = \frac{mol_{maj} - mol_{min}}{mol_{maj} + mol_{min}} \quad 2$$

Kinetic resolution can also be done using enzymes, which has become a widespread method and is often done using the enzyme group called lipases. Lipases can be used selectively in both hydrolysis and esterification, depending on the solvent chosen. (10) Lipases from the yeast *Candida antarctica* are very commonly used, specifically the lipases called lipase A and lipase B, abbreviated CALA and CALB respectively. An example of the kinetic resolution with CALA is shown below in Scheme 2, where Jacobsen *et al.* has resolved racemic stiripentol. (11)

Theory

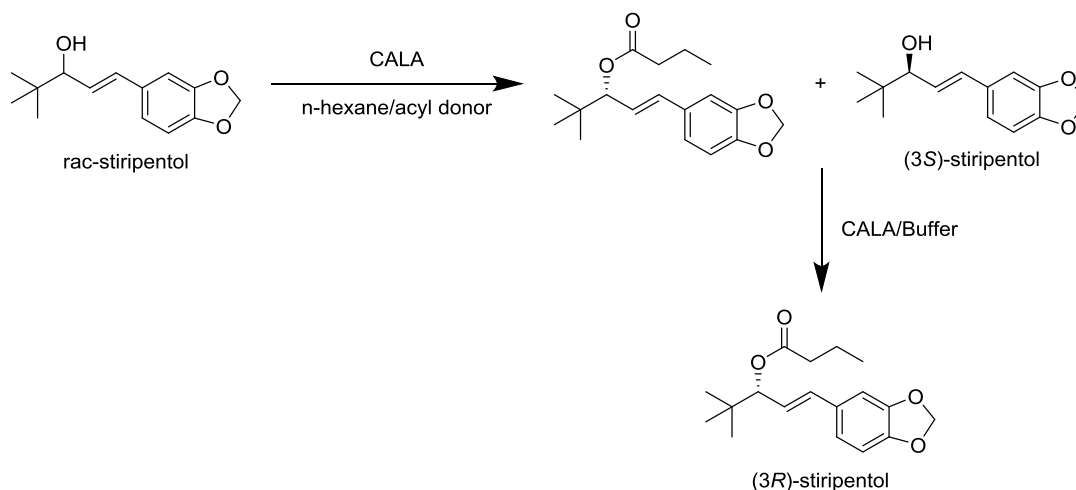

Scheme 2: Racemic stiripentol resolved using CALA. (11)

The main issue with kinetic resolution is the maximum yield cannot exceed 50%. This may seem contradictory at first, but considering that a racemic mixture consists of equal amounts of two enantiomers and ideally only one of the enantiomers will react, the other enantiomer will remain. Therefore half of the substrate will remain unreacted. (6, 12) A possible way to work around this issue is by dynamic kinetic resolution, where a method is devised so that the remaining substrate is racemized so that the reactive enantiomer will always be present. This is most commonly done with enzymes or metallic catalysts, chosen so that they quickly and continuously racemize the substrate, but have no effect on the product. (6, 9)

Moving on to the next section in Figure 3, asymmetric synthesis is another major aspect of synthesizing enantiomerically pure compounds. The concept of asymmetric synthesis is to direct the reaction so that the reactants ideally only produce one of the enantiomers. The reactant is usually not chiral, but becomes chiral during the reaction. Such reactants are called *prochiral*, and a reaction that results in an enantiomeric excess of the product enantiomer is called *stereoselective*. (3, 8) In order to react stereoselectively, either the reaction mechanism must favor one enantiomer over the other, or chirality must be introduced to the reaction by other means, usually by a catalyst. As with kinetic resolution, the catalysts used can be chemical or biological. A simple example of this could be the stereoselective reduction of the allylic alcohol seen in Scheme 3.

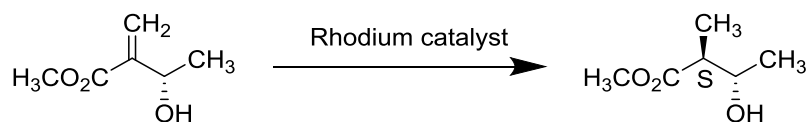

Scheme 3: Stereoselective reduction of an allylic alcohol, yielding 99 % of the S-enantiomer. (13)

The importance of stereoselective reactions was shown in 2001, when William Knowles, Ryoji Noyori and Barry Sharpless won the Nobel Prize in Chemistry for their work in catalytic stereoselective reactions. Knowles for his discovery and application of a ruthenium complex with a chelating diphosphine called DIPAMP (14), Noyori for his discovery and application of a ruthenium complex with BINAP (15), and Sharpless for his work with epoxide oxidation with titanium tetrakisopropoxide. (16, 17) BINAP has already been shown in Figure 2(b), while DIPAMP and the titanium complex can be seen below in Figure 4. The structure for Sharpless' titanium complex is not conclusively proven, but is thought to have the structure below based on experimental data. (18)

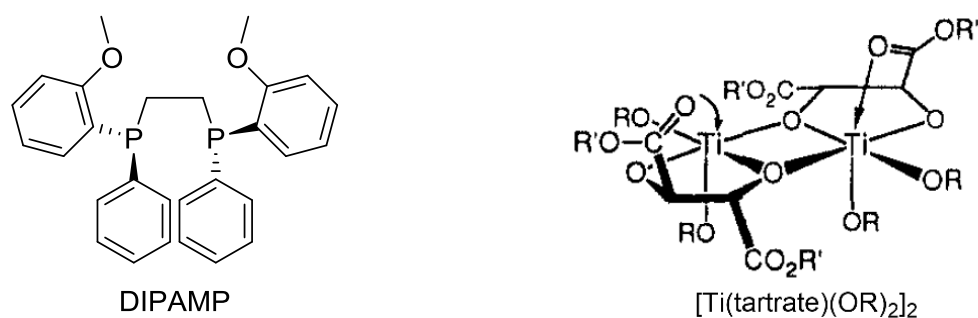
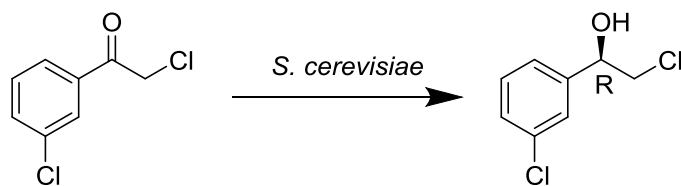

Figure 4: The structure of DIPAMP and the proposed structure of Sharpless' titanium complex. (14, 18)

As illustrated in the examples above, catalysts used in stereoselective reductions are often complex, using transition metals. An alternative to these complex transition metal catalysts would be biocatalysts.

Again mirroring the situation for kinetic resolution, the conventional metallic catalysts can be exchanged for biocatalysts with similar enantioselectivities. In terms of catalytic activity in biology, enzymes are the most used tools. A commonly used enzyme is the alcohol dehydrogenase (ADH) found in common yeast, *Saccharomyces cerevisiae*. An example of this can be seen below in Scheme 4, where an acetophenone is stereoselectively reduced to its corresponding secondary alcohol. (19) Biocatalysis in general will be discussed in greater detail in Section 2.3.1.

Theory



Scheme 4: Enantioselective reduction of an acetophenone, 2,3'-dichloroacetophenone, to a secondary alcohol, (*R*)-2-chloro-1-(3-chlorophenyl)ethanol, using yeast as a biocatalyst. (19)

The last route to achieving an enantiomerically pure product is simply to use enantiomerically pure compounds already available as reactants. Vast amounts of enantiomers are found naturally, many from natural fermentation. The naturally found enantiomers that can be used in organic synthesis are collectively called the *chiral pool*. Alternative sources of chiral compounds could be vitamins, amino acids, or even hormones. In some cases, enantiomerically pure compounds made on an industrial scale are considered part of the chiral pool. (20, 21)

2.1.3 Chirality in medicine

Returning to the idea of receptors reacting differently to different enantiomers, mentioning the tragic example of thalidomide is inevitable. Thalidomide is a mild sedative and was developed in the 1950s and marketed as a sleeping pill (22) and later in the 1960s to alleviate the symptoms of morning sickness in pregnant women (3). In 1963, it was discovered that thalidomide caused *teratogenesis*, severe birth defects, in what has been estimated to be 10 000 fetuses. Subsequently it was found that only one of the enantiomers had this teratogenic effect, namely the *S*-enantiomer. The *R*-enantiomer did not have this effect, but still acted as a sedative. Further study showed that even if the pure enantiomer was administered, the molecule racemized *in vivo* (3, 22, 23) and would still result in birth defects if given to pregnant women. Due to situations like these, the US government has become aware of the importance of chirality and as a result, both of the two enantiomers and the racemate must be studied individually during the course of the drug design. (3, 22)

The emphasis on stereochemistry began in the 1980s, when making enantiomerically pure compounds in substantial amounts became possible. In this period, it was already commonly accepted that only one of the enantiomers in a racemate was responsible for the biological activity. The US Food and Drug Administration (FDA) took a clear stand in 1986 when a senior official told a large audience at an international scientific meeting that the FDA wanted racemic drugs to be resolved and to characterize the individual enantiomers. Doing this, the

FDA had chosen a clear direction in which they wanted take the drug industry and in 1992 this became a part of their official policy statement. (23)

When a new drug is approved and marketed, it becomes registered as a new molecular entity (NME). The definition of NMEs as given by the FDA is "An active ingredient that has never before been marketed in the United States in any form." (23) Not surprisingly, the number of racemic NMEs registered worldwide has declined steadily since the FDA made their statement (23), as can be seen in Figure 5.

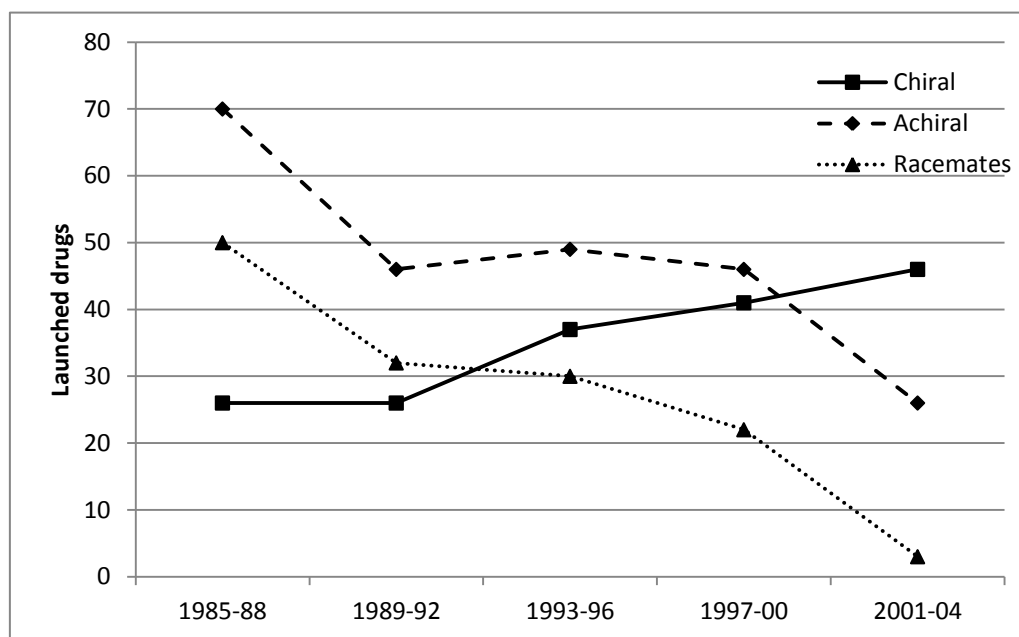

Figure 5: New NMEs launched 1985-2004, divided by chiral, achiral and racemic. (24)

Regarding registering chiral NMEs, it is important to note that something called ‘chiral switching’ or ‘racemic switching’ may affect the numbers. Racemic switching is when a company owns the patent for a drug containing the different enantiomers of a NME and starts marketing the single enantiomer independently, and under a different patent. (22-25) In order to do so, there must be evidence showing that the ‘new drug’ is an improvement over the previous. (22) This is a controversial topic, as the single enantiomer does not always have a clinical benefit over the racemic mixture. Even though only one of the enantiomers, the *eutomer*, is biologically active and the other, the *distomer*, is inactive, it may be cheaper to use the racemic mixture, but in some cases, the pharmaceutical companies chose to do the chiral switch as to maximize the potential profit from the molecule. In other cases, the distomer may be responsible for unwanted side effects and developing single enantiomer drugs could increase both the safety and efficacy of the treatment, being a direct improvement of the original racemic drug. A specific example of a debated chiral switch would be omeprazole (Figure 6),

Theory

marketed and sold as the racemate Prilosec by AstraZeneca. The racemate was approved in 1989 and earned the company over \$6 million per year in the US by 2000. The patent ended in 2001 and its market exclusivity ended. Shortly after, the eutomer, (*S*)-omeprazole was patented with the brand name Nexium, by the same company, thus further securing the market share. By some, this has been regarded as a "corporate waste of healthcare resources". (25)



Figure 6: (*S*)-omeprazole and (*R*)-omeprazole

2.2 What is asthma?

Simply stated, asthma is a condition in which the airways are chronically inflamed, causing irritability of the mucous membrane in the air passages. Symptomatic for this condition is recurring episodes of shortage of breath, wheezing and coughing, varying in intensity from individual to individual. (26-28)

The cause of asthma is not completely understood, but the strongest risk factors are thought to be a combination of genetic predisposition and inhalation of airborne particles, such as dust, dust mites, tobacco smoke, pollen, chemical irritants and air pollution. (28)

2.2.1 Prevalence and cost

Historically, asthma has been known since ancient Egyptian times, being treated with herbs, as described in the Ebers Papyrus. The word *asthma* originates from the Greek verb *aazein*, which means panting, and the earliest text using 'asthma' in a medical context is *Corpus Hippocraticum*, by Hippocrates, although it is not known whether 'asthma' was used to describe the condition or the symptom. Closer to modern times, treatment resembling today's medicine has been used in China since around 200 AD where medicinal herbs were ingested to treat allergic asthma. (29) The fact that asthma was an inflammatory disease was not discovered until the 1960s when anti-inflammatory medication became used. (30)

In a 2013 press release, UN estimated the world's population to be 7.2 billion (31), while the WHO estimated asthma to affect over 235 million people. This means that in 2013, approximately 3.3 % of the world's population suffered from asthma. Furthermore, WHO reports that asthma is both under-diagnosed and under-treated, which means that the real numbers are

2.2 What is asthma?

probably significantly higher than the official numbers. Asthma is a common disease in all countries regardless of level of development and it is the most common non-communicable disease among children. (28)

Figure 7 shows the increase in number of prescriptions given for asthma and chronically obstructed pulmonary disorder (COPD) in Norway over the last decade. Considering the similarity between the symptoms of the two conditions, they are hard to separate and as such, the graphical representation cannot discriminate between the two. In addition, the statistics are only for Norway, a country that has had a high standard of living for a longer period, therefore excluding the developing countries of the world, where asthma is a bigger problem. (32)

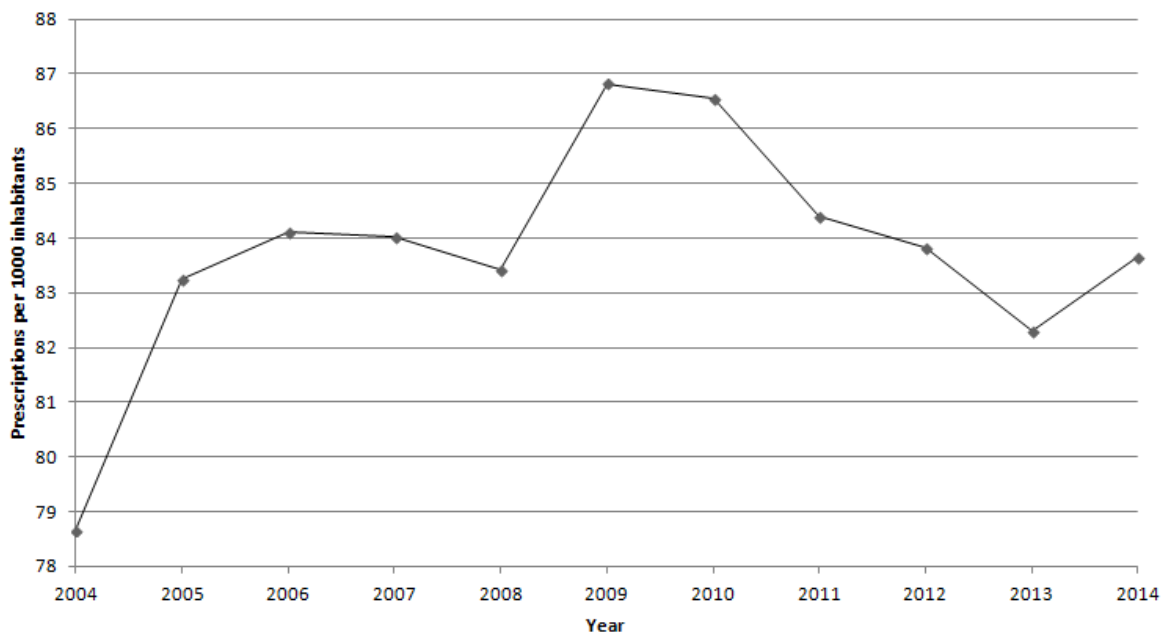

Figure 7: Development in number of prescribed asthma and COPD prescriptions in Norway. (33)

A study done in 2011 found that the mean cost of asthma in patients aged 30-54 years was €1,583 in 2010, and when extrapolated to include the whole European population, ages 15-64, the total cost of asthma for 2010 was €19.3 billion. The mean cost per patient was highly influenced by the degree of control of the disease, and conditions such as chronic cough or phlegm as well as a high BMI all increased the cost. Perhaps not very surprisingly, the main contributor to the cost of asthma was the indirect costs, such as lost working days. (34) A similar study was done in the United States of America in 2009, and they concluded that asthma cost the USA \$56.3 billion, equal to €40.1 billion in 2009. (35) When considering the European and the American study, the impact and prevalence of asthma is apparent and that effi-

Theory

cient control of asthma, e.g. with efficient medication, could reduce the huge amounts of unnecessary expenses related to asthma.

2.2.2 Physiological cause and effect

To understand the effect asthma has on the human respiratory system and how to treat it, it is important to first gain an insight in what it is and how it functions. The following section will explain the pathophysiology of asthma.

The human respiratory system (Figure 8) starts with the nasal cavity and goes down the trachea. Here it branches off into two *bronchi*, one for each lung. These bronchi branch off into smaller and smaller tubes called *bronchioles*, and at the end of the smallest bronchioles are clusters of air sacs called *alveoli*. This is where the gas exchange in humans occurs, where oxygen enters the blood, and carbon dioxide leaves. (36)

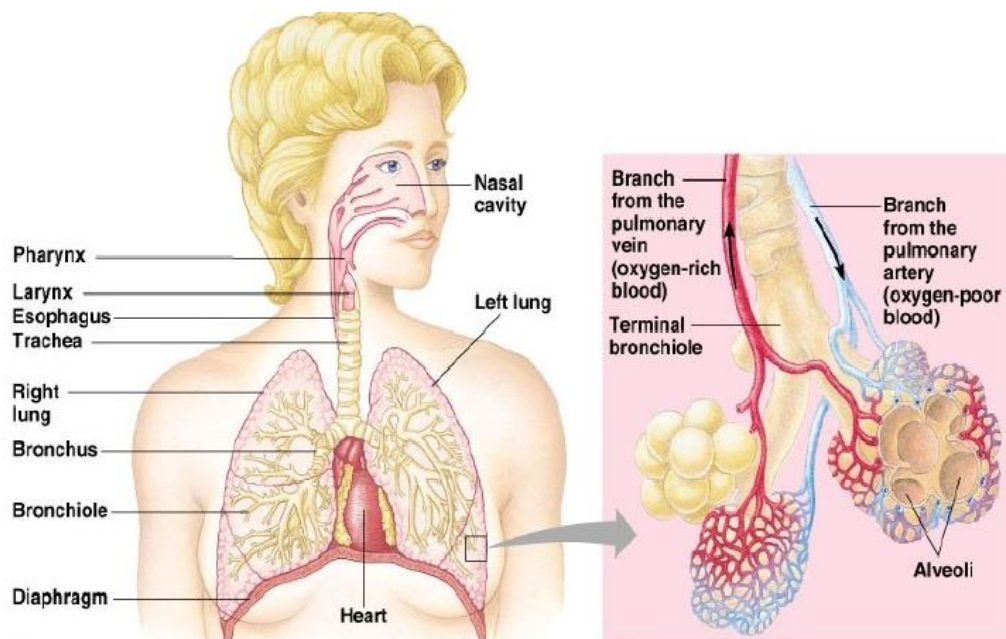

Figure 8: The human respiratory system, with a close-up of a terminal bronchiole with belonging alveoli. (36)

The epithelial cells lining the larger bronchioles are covered in mucous and small hairs called *cilia*. The mucous is there to capture foreign particles, such as pollen and dust, and the cilia carry the particles towards the throat, allowing it to be swallowed. (36)

There are two main types of asthma, atopic and non-atopic asthma. Atopic asthma can also be called allergic or extrinsic asthma and is caused by external stimulation, mainly by allergens. The second type of asthma is the non-atopic, or intrinsic asthma. Intrinsic asthma is often a

2.2 What is asthma?

secondary diagnosis to chronic inflammations in the airways and exhibits the same symptoms as extrinsic asthma, but the immune system is not involved in the exacerbation of the condition. Rather than allergens, intrinsic asthma is caused by other factors such as stress, exercise, dry air, smoke, or other irritants. (37) Most data on the pathophysiology of asthma examine the atopic type, which will also be the main focus here.

Atopic asthma can be considered an immune disorder, and many factors are involved, all related to the immune system. The immune system is based on a variety of *granulocytes* (white blood cells, Figure 9), such as leukocytes, eosinophils and basophils, that cooperate in order to prevent and fight diseases or infections. The immune system is based on two separate systems: the humoral immune system and the cellular immune system.

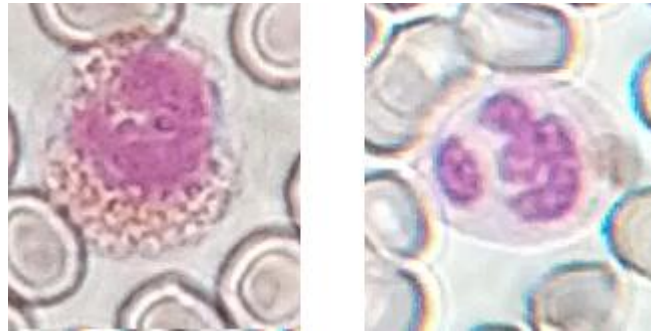

Figure 9: Two types of granulocytes: eosinophil (left) and leukocyte (right). (38)

The cellular immune system fights cells infected by viruses, and destroys parasites. The humoral immune system (Latin *humour*, "fluid") fights bacterial infections and viruses found in body fluids. The humoral system works by *immunoglobulins* (Ig), Figure 10, binding to foreign bacteria, viruses or large molecules, marking them for destruction. The Ig are produced by the B cells, and make up 20 % of the blood protein. When Ig are made, they have two branches that bind to the specific antigens to which the B cells were exposed. The base fragment interacts with leukocytes that will activate and attack the antigen that triggered the Ig.

Theory

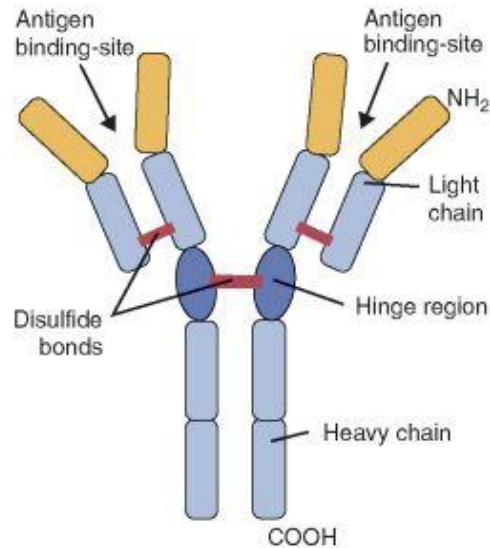

Figure 10: The structure of immunoglobulins. (39)

In the cellular system, T cells are responsible for destroying foreign cells. This happens when cytotoxic T cells (T_C cells) recognize the foreign cells using T-cell receptors found on the surface of the T cells. Another type of T cells, called helper T cells (T_H cells), helps the immune system by producing different cytokines, including interleukins (IL), which stimulates T_C cells and B cells that can bind to specific antigens. (40)

As there are two different systems working together, there are two phenotypes of T_H cells which can stimulate either T_C cells or B cells. The T_H -1 phenotype, promotes cell mediated immunity by stimulating T cells, and the T_H -2 phenotype, promotes humoral mediated immunity by stimulating B cells. Normally, there is a balance between the two phenotypes determined both by genetic and environmental factors, but it is found that atopic asthmatics are often predisposed towards the T_H -2 phenotype. This is illustrated by Figure 11 below. As shown in the figure, the different phenotypes also influence the different IL produced. (41)

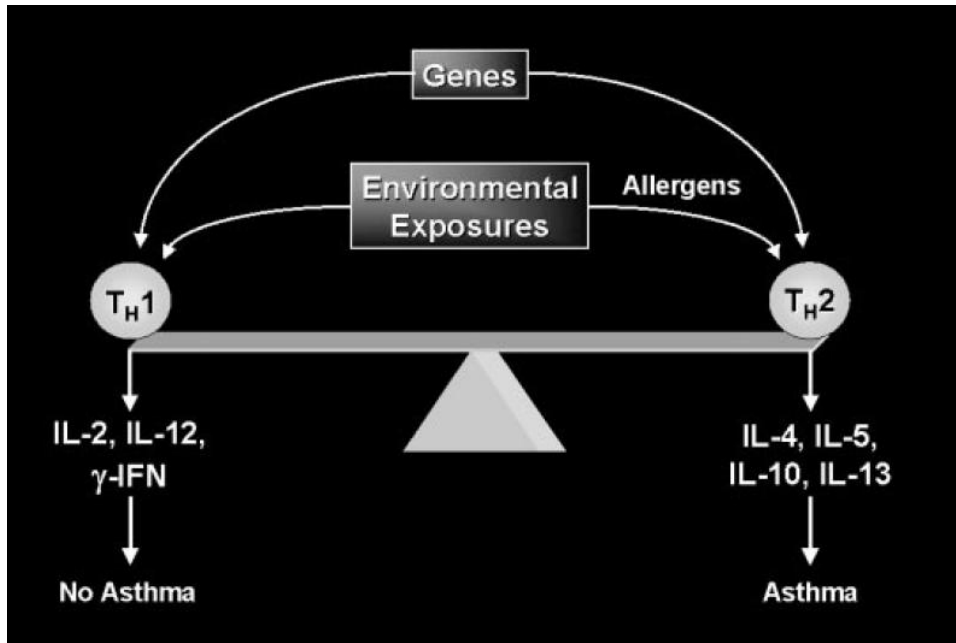

Figure 11: Illustration showing how the different T_H phenotypes affect asthma. (41)

As mentioned, inhaled irritants and allergens are usually cleared by the cilia lining the bronchioles, but sometimes the allergens bypass the mucous and penetrate the underlying epithelium in the alveoli. When this happens, circulating *dendritic* cells, a type of messenger cell for the mammalian immune system, engulf the allergens and migrates to the nearby lymph nodes. When the dendritic cells reach the lymph nodes the allergens are presented to the T cells and the B cells, and the B cells start producing immunoglobulin E (IgE). This is a specific class of Ig that binds to *mast cells*. Mast cells are large mononuclear cells that stores granules filled with histamine, tryptase, chymase, eicosanoids and T_H -2 like cytokines. In the future, exposure to that specific antigen will lead to what is called mast cell activation. The IgE on the surface cross-links and causes a release of the granules mentioned. Normally this does not cause any harm to the person, but that is not the case for asthmatics and the allergic. (41)

The issue with atopic asthmatics is that the T_H -2 phenotype helper cells produce excessive amounts of the specific interleukins indicated in Figure 11, namely IL-4, IL-5, IL-10 and IL-13. IL-4 and IL-13. These IL are responsible for the B cells production of IgE and due to the excessive amounts of these interleukins in asthmatics, there is an overproduction of IgE. It has been shown that blocking IL-4 during antigen sensitization completely negates the development of atopic asthma. The exaggerated amount of IgE causes the activation of too many mast cells and a more severe reaction than non-asthmatics. As the chemicals in the released granules are toxic, the symptoms of an acute asthma attack present themselves. Histamine causes contraction of the smooth muscles in the airways (42), tryptase intensifies the effect of hista-

Theory

mine and chymase appears to be toxic to the airway cells. These three chemicals are responsible for the initial reaction of an asthma attack. The release of eicosanoids and cytokines cause the late reaction phase. They recruit further eosinophils, leukocytes and macrophages, and when the late phase has begun, the eosinophils are mostly responsible for the inflammation. They do this by releasing a cocktail of harmful chemicals that cause tissue damage, constrict the smooth muscles, and increase the permeability of the membrane in the airway. The increased permeability of the membrane leads to further more eosinophils and T_H -2 type cells in the airway. This harmful cycle can eventually lead to chronic inflammation of the airways, without allergens even being present. Again, the T_H -2 phenotype being more dominant in asthmatics exacerbate the reaction by producing more IL-5, which causes production of even more eosinophils. (41)

In this thesis, we are interested in the *bronchoconstricting* properties of histamine and how to counteract it. This property comes from a chain of events that starts with histamine binding to a type of receptors called H_1 receptors. (43) These are part of a group of receptors called G protein-coupled receptors (GPCRs) which are amongst the most common receptors in medicine, targeted by almost half of the drugs on the market. (40) These GPCRs consist of long amino acid chains, crossing the cell membrane seven times, seen in Figure 12, and can have a variety of effects when transducing signals from the cell membrane to intracellular secondary messengers. (44) In the case of histamine, the H_1 receptor activates phospholipase C (PLC), which hydrolyses phosphatidylinositol 4,5-bisphosphate (PIP_2) to diacyl glycerol (DAG) and phosphatidylinositol 1,4,5-trisphosphate (PIP_3). PIP_3 then migrates through the cell membrane and binds to IP_3 receptors that allow calcium ions through the membrane. The increase in intracellular calcium ions causes airway smooth muscles to contract, causing breathing problems in asthmatics. (43) Another effect of histamine is that it increases the growth of smooth muscle cells in the airways, amplifying the bronchoconstricting effect of histamine. (42)

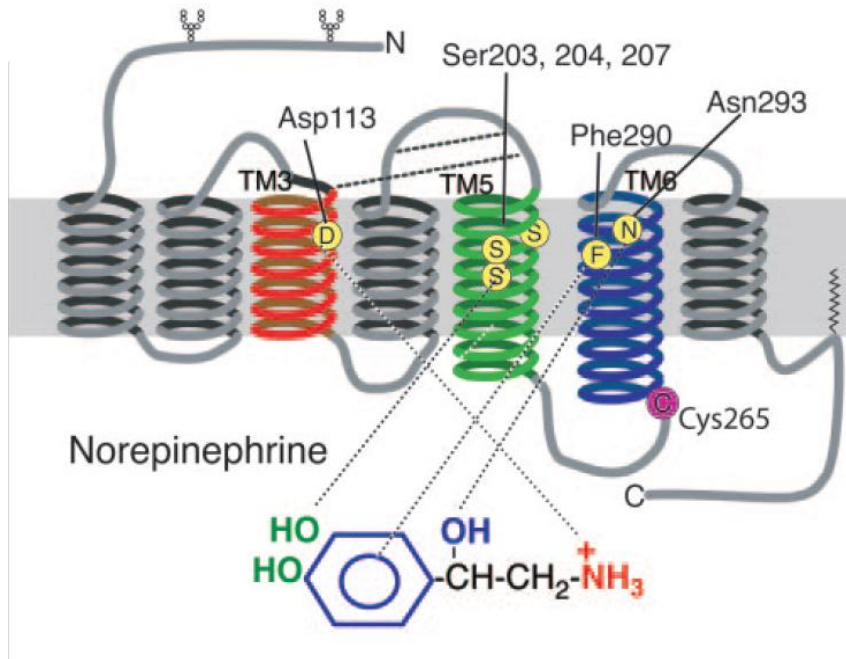

Figure 12: Norepinephrine shown how it fits in the active site of a GPCR, this specific GPCR being a β_2 -adrenergic receptor. (45)

2.2.3 Medication

Based on the mechanism of histamine and the H_1 receptor, histamine is the natural *ligand* of the receptor. If a synthetic compound was made to mimic the effect of histamine, it would be called an *agonist* to the H_1 receptor. A synthetic compound made to bind to the active site, but not cause the histamines effect, thus blocking the receptor would be called a histamine *antagonist*. (40) A group of chemicals that serve as antagonists to histamine are commonly called antihistamines, commonly used to treat allergies. Although it seems that antihistamines would prevent asthmatics from having asthma attacks by blocking the effect, this is not the case. A meta-analysis found that antihistamines had approximately the same effect as a placebo when taken in order to control asthma. (46)

In order to treat asthma it has therefore been found more effective to either use corticosteroids, or target another type of GPCRs, namely the adrenergic receptors. There are four different subtypes of adrenergic receptors, divided into α_1 , α_2 , β_1 and β_2 , separated by their affinities to different agonists and antagonists, and their corresponding response. (22, 40) The α adrenergic receptors are responsible for smooth muscle contraction, while the β adrenergic receptors (β AR) are responsible for contraction in cardiac muscles and relaxation in smooth muscles. The β ARs that most selectively targets the smooth muscles in the airways are the β_2 ARs, illustrated in Figure 12, and is therefore the most targeted receptor for asthma medica-

Theory

tion. The natural ligand for the β_2 AR is epinephrine, shown in Figure 13. The most common medications intended to treat the initial phase of an asthma attack are therefore synthetic analogs to epinephrine, which are called β_2 AR agonists.

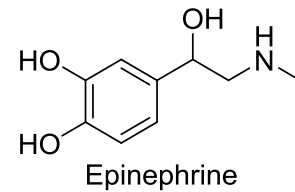

Figure 13: Molecular structure of epinephrine.

The mechanism that causes epinephrine and its analogs to cause bronchodilation is illustrated in Figure 14 below. The epinephrine, or the agonist, binds to the specific receptor in the β_2 AR, causing a conformational change in the receptor. This change activates the G_s subunit of the receptor by changing bound GDP to GTP, which then causes a part of the G_s subunit to detach and go on to activate another enzyme in the cell membrane, adenylyl cyclase (AC). AC is vital to the synthesis of cyclic AMP (cAMP) from ATP, which leads to an activation of cAMP-dependent protein kinase, called protein kinase A (PKA). (40) The PKA then goes on to phosphorylate more protein modulators. Overall, this pathway inhibits the hydrolysis of IP_2 by PLC and activates the K^+ -ion channel, causing a fall in intracellular Ca^{2+} levels and large conductance of K^+ . The inhibition of PLC counteracts the activation by histamine mentioned in Section 2.2.2, (47) and the opened K^+ channel causes bronchodilation. (48)

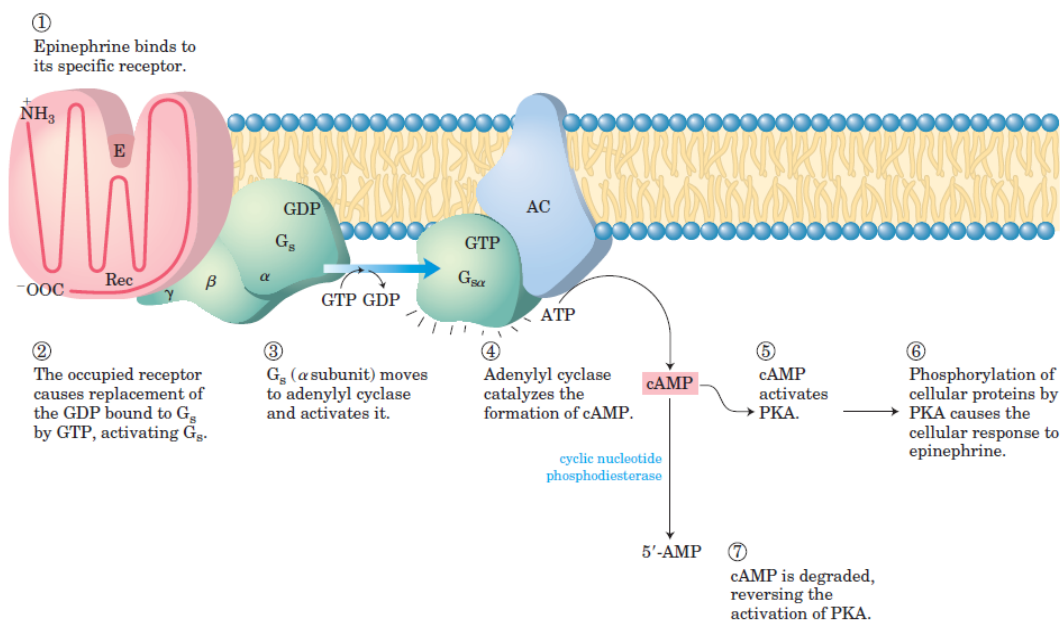

Figure 14: The GPCR pathway when activated by epinephrine. (40)

There are three main groups in terms of different medications; asthma attack relief, asthma attack preventives and asthma preventives, with the active molecules being mostly short-

2.2 What is asthma?

acting β_2 AR-agonists (SABA), long-acting β_2 AR agonists (LABA) and corticosteroids, respectively. (49)

The β_2 -agonists are, as previously implied structurally related to epinephrine, as can be seen in Figure 15 for the SABA and Figure 16 for LABA. The mechanism of both types of β_2 AR-agonists have already been outlined and is visualized in Figure 14 above. The SABA are named so due to their fast onset and short period of action. Salbutamol has the highest affinity for the β_2 AR of the SA agonists. Salbutamol reaches maximum bronchodilation after 15 minutes and the SABA are generally active for 4-6 hours, while the natural ligands are metabolized after only 1-2 hours. The short activation time and short duration makes them effective for acute asthma attacks, but less so as a preventive measure. As such, they should be used on an as-needed basis, being at the lowest dose and frequency necessary. (47) An important structural difference of salbutamol, compared to epinephrine, is that the group in the meta position is an aldehyde, as opposed to an alcohol. This has been shown to affect the position in the active site to such an extent that the active site no longer overlaps with the catecholamine group (benzene ring with two hydroxy groups) found in epinephrine. (45) Some marketed SABA are; salbutamol under the trade names Airomir and Buventol, and terbutaline under the trade names Bricanyl and Terbasmin. (49)

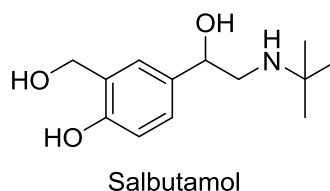
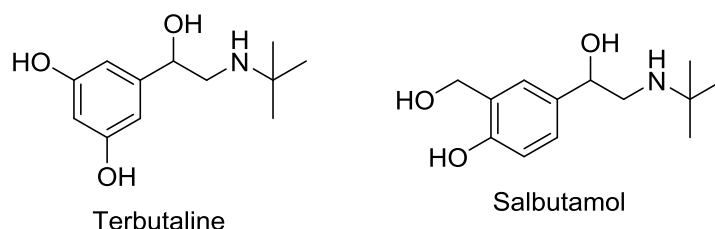

Figure 15: Short-acting β_2 -agonists

LABAs are, as the name indicates, active for longer than the SABAs. The LABAs remain active for about 12 hours. The cause of this change in duration is the longer and more hydrophobic amine chain, as can be seen in Figure 16. This chain increases the affinity to the receptor, but also increases the time it takes to bind to the receptor. Salmeterol's hydrophobic chain causes it to diffuse in and out of the cell membrane, while moving towards the active site. Due to this movement it takes more than 30 minutes for salmeterol to activate the receptor, it is suggested that salmeterol's long chain binds to an external site and keeps the head in the active site longer. Thus, salmeterol has a longer activation time, but after activation the effect lasts longer. Formoterol has a slightly higher effect than salmeterol, but lasts shorter. Salmeterol is marketed as Serevent, and formoterol is marketed as Foradil and Oxis. (47, 49)

Theory

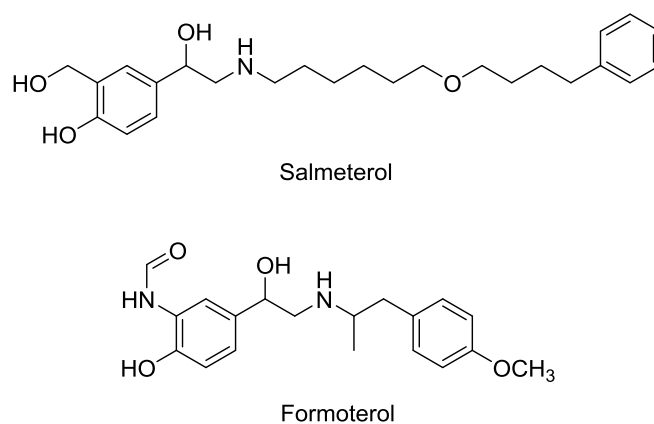

Figure 16: Long-acting β_2 AR agonists

In the last decade, some development has been done on β_2 AR agonists and a new, more unusual type has become increasingly common: the ultra long-acting β_2 AR agonist (Figure 17). Amongst them is indicaterol. It was approved in Europe in 2009, and has become marketed in several countries. Indacaterol has been found to have an activation time comparable to salbutamol, and with a bronchodilating effect that lasts for 24 hours, being ultimately more effective than other β_2 AR agonists. (47) Another ultra LABA, olodaterol, has been on the market since October 2013, under the name Striverdi. (50) Olodaterol has a potency comparable to that of formoterol, but with a longer lasting effect. (47) Several other ultra LABAs are under development with the goal of making efficient LABAs that can be ingested on a once-a-day basis. (51) Due to the long period of effect, LABAs are effectively used as a preventative measure.

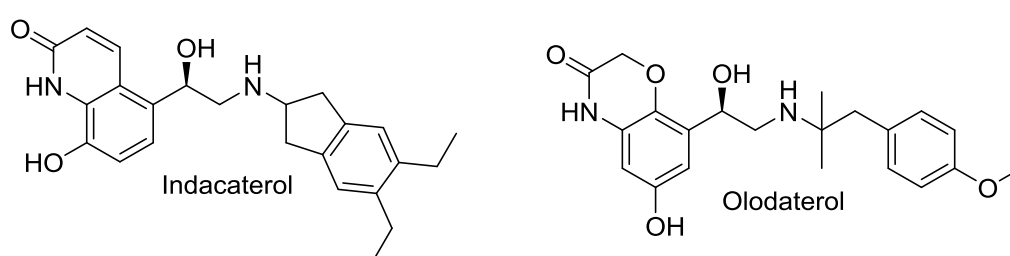

Figure 17: Ultra long-acting β_2 AR agonists

An issue found in the group of β_2 AR agonists as a whole, is that resistance may be built up by the desensitization of the GPCR. When the receptor has been activated and the G_s subunit has left, the remaining subunit can be phosphorylated, which attracts a protein that binds to the receptor, effectively blocking further action. This leads to the entire GPCR leaving the cell membrane, migrating into the cell. Eventually the subunit is dephosphorylated and the GPCR can return to the membrane. This mechanism causes asthmatics to become progressively less

2.2 What is asthma?

sensitive to β_2 AR agonists, but the responsiveness will return to normal after 3 days if treatment is stopped. SABAs have been blamed for an increase in the mortality and morbidity of asthma that happened as SABAs were introduced to the market. They have also been linked to an increased asthmatic reaction. LABAs have been linked to deaths in asthmatics, which has caused the FDA to stop monotherapy with LABAs, but these effects are only seen when the β_2 AR agonists are used over a period of time and the use of LABAs have been found to be safe in combination therapy with corticosteroids. Another noteworthy point regarding β_2 AR agonists is that due to their selectivity towards the β_2 AR, they may also be selective towards the β_1 AR, which would cause an increase in heart rate. The selectiveness towards this receptor varies greatly between the β_2 AR agonists, but care should be taken as heart related issues might arise, such as arrhythmia or tachycardia. (47)

The last main group of medication is called corticosteroids (Figure 18) and they are used as a preventive measure for asthma. Unlike the β_2 AR agonists, the corticosteroids are not able to stop an ongoing asthma attack, but are instead used to reduce the overall reaction. This is done by binding to steroid receptors that suppress the transcription of genes, preventing the synthesis of inflammatory proteins. In short, these receptors prevent the unwinding of DNA so that the transcription proteins are unable to access the DNA strand. (52)

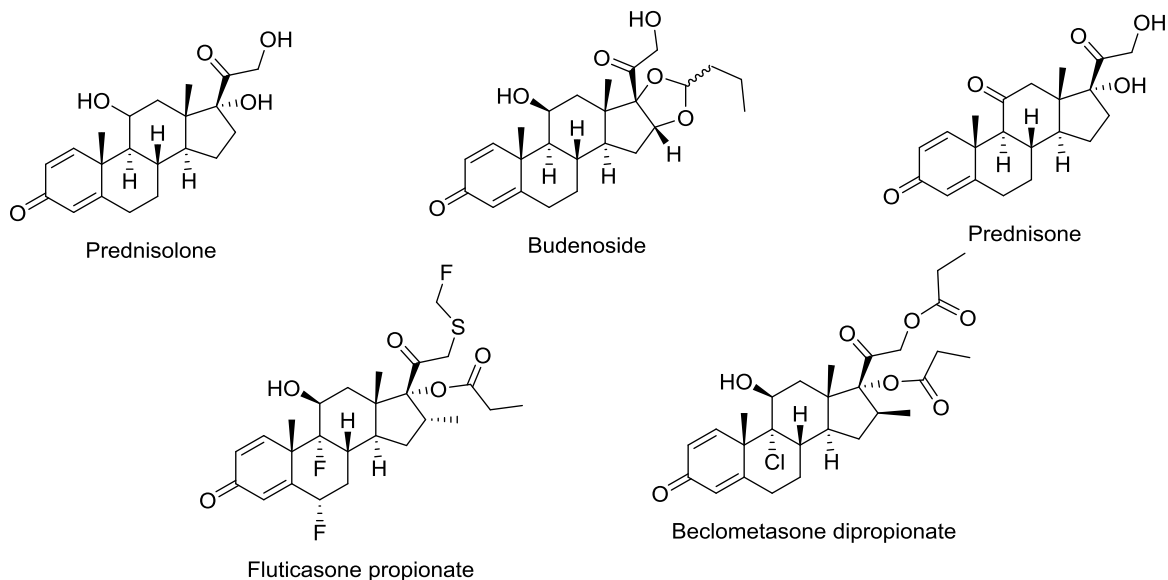

Figure 18: Corticosteroids

Theory

When these genes are inhibited, a range of changes occurs due to the nature of DNA transcription. A graphical representation of these changes can be seen in Figure 19 below.

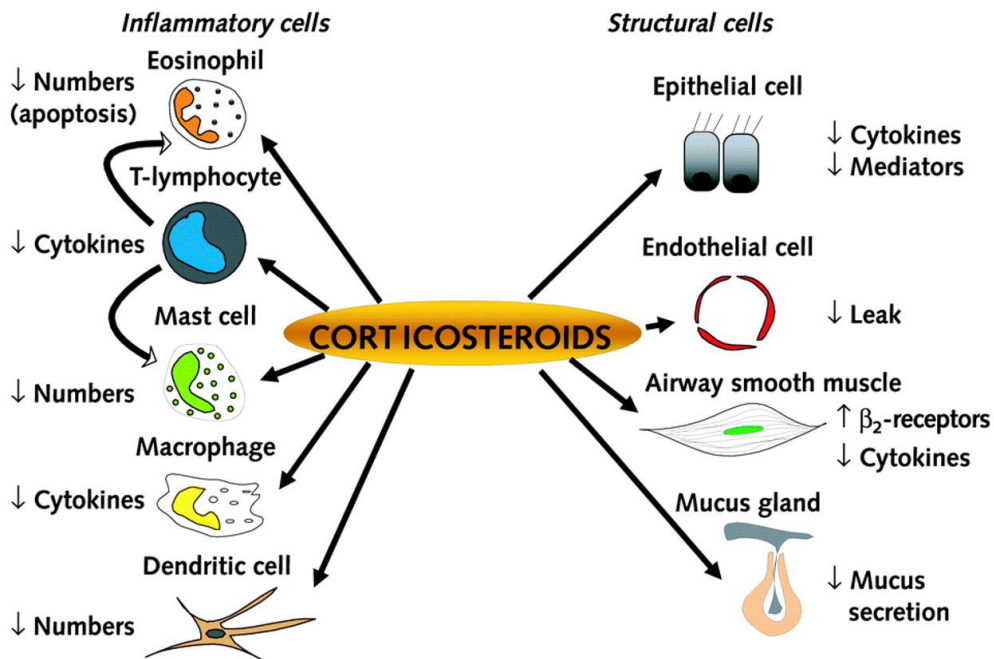

Figure 19: Overview over the different effects treatment with corticosteroids have. (52)

Some medicaments are designed to be antagonists to a GCPR called the muscarinic acetylcholine receptor (mAChR). These receptors stimulate bronchoconstriction, and blocking these receptors with antagonists cause bronchodilation. The effect of these mAChR antagonists are comparable to those of the β_2 AR agonists, and the effect is slightly slower but longer. (47) Examples of mAChR antagonists are ipratropium and atropine, seen in Figure 20 below.

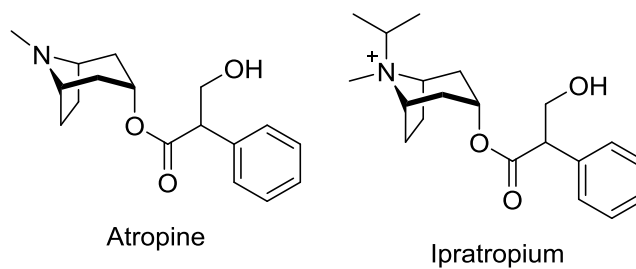
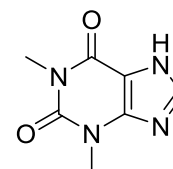

Figure 20: mAChR antagonists

Another way to treat asthma is to use antibodies to block receptors. Some examples of this could be omalizumab, that binds to IgE and prevents the binding of antigens; lebrikizumab, that blocks IL-13; dupilumab, that blocks IL-4; mepolizumab and benralizumab, that blocks IL-5; and brodalumab, that neutralizes the receptor for IL-17. (53)

2.2 What is asthma?

Last is a chemical group called xanthines, most commonly represented by theophylline (Figure 21). These compounds inhibit phosphodiesterase (PDE). This elevates the intracellular levels of cAMP, and further inhibits the synthesis of leukotriene. (54)



Theophylline

Figure 21: Theophylline, a methylxanthine

There are several other methods with bronchodilating effects used for treating asthma that will not be visited in this thesis, including K^+ channel openers, Rho kinase inhibitors, leukotriene receptor antagonists, brain natriuretic peptides, nitric oxide donors, etc. (47)

The 'ideal' treatment for asthma will probably never be found, but clinical studies have shown that combinational therapy using several of the methods mentioned above are very successful. Most commonly used is the combination of LABAs and corticosteroids, gaining most of the positive effects and reducing the side effects due to the smaller doses. Examples of such treatments could be Inuxair, using beclometasone dipropionate and formoterol; Flutiform, using fluticasone dipropionate and formoterol; and Symbicort, using budesonide and formoterol. (47, 52) A lot of development and studies are still going on, producing interesting results, indicating an interest for improvements in the industry. (51) The need for new and better asthma medication can also be seen by the market for asthma medication in the pharmaceutical industry worldwide, being valued at \$34.15 billion in 2012. (55)

2.2.3.1 Ventoline vs. Xopenex

As mentioned previously, it is a well-established fact that an enantiomer pair of medical compounds has one eutomer and one distomer. (56) It has been found that the β AR are stereoselective regarding the β AR agonists and only the *R*-enantiomers in the medications used are active. (57-60) As a result, it is more favorable to optimize the synthesis of pure enantiomers and do a chiral switch, where possible. (61) The focus of this thesis is to successfully synthesize the eutomer of salbutamol, the *R*-salbutamol named levosalbutamol, using effective biocatalytic methods. Salbutamol is one of the medications that has undergone a chiral switch, but under conflicting opinions. The chiral switch from salbutamol to levosalbutamol has been debated for two reasons: The clinical advantage has not been definitely proven in clinical trial (59, 62) and the cost of levosalbutamol is about five times higher than that of racemic salbutamol. Racemic salbutamol is marketed as Ventoline for \$5-30 per inhaler, while levosalbutamol is marketed as Xopenex for \$50 per inhaler. (63) This increase in cost might be explained by the fact that the second to last step of the synthesis is resolution of the enantiomers by crystallization with tartaric acid, halving the possible yield. (24)

Theory

However, many published articles favor the switch to levosalbutamol. Some of the articles have found direct advantages in the therapeutic profile that could not be matched with racemic salbutamol. (64) Other articles have found disadvantages with *S*-salbutamol, such as it being metabolized 12 times slower than levosalbutamol. (65) This slow metabolism might lead to a buildup of *S*-salbutamol in the body, which causes cytokine production and an increase in intracellular Ca^{2+} , leading to bronchoconstriction. (59) In addition, it has been shown to increase bronchial hyperresponsiveness, but this has not been consistently proven in clinical trial. (62) However, it has been found that levosalbutamol somehow decreases the number of admissions to the hospital (47, 66, 67) and that admissions cost generally less due to a higher rate of discharge. (66)

A meta-analysis by Jat (2013) concluded that the levosalbutamol is only slightly more advantageous to racemic salbutamol, but not enough for it to be worth the increased cost. This is shown by the fact that a double dose of racemic salbutamol has a slightly lower effect than levosalbutamol. Since racemic salbutamol is 50 % levosalbutamol, the doses would contain the same amount of levosalbutamol, which indicates that the *S*-salbutamol has no clinical effect apart from the slight disadvantages it offers. (59)

Although a debated topic, it seems that salbutamol is the better choice regarding emergency treatment of acute asthma attacks amongst the different treatments available, and for salbutamol, the enantiomerically pure levosalbutamol is an improvement on the racemic compound.

2.3 Synthetic route

When finding a new synthetic route to levosalbutamol, it is important to find the motivation for doing so. In order to improve a synthesis, the issues with the current synthesis must be reviewed. As mentioned, one of the issues with levosalbutamol is the price and therefore the cost effectiveness of the overall synthesis has been targeted. Although the cost of levosalbutamol is higher than comparable $\beta_2\text{AR}$ agonists, high production cost is prevalent throughout the entire pharmaceutical industry.

The wastefulness of organic synthesis in industrial processes from an environmental point of view, especially in the pharmaceutical industry, becomes apparent when comparing the "E factor" between the different industries. The E factor was a term introduced by Roger A. Sheldon to describe the amount of waste produced compared to the amount of product, using Equation 3 below. (68) In the pharmaceutical industry, the E factor is usually 25-100, which is considerably higher than for bulk chemicals (<1-5) and fine chemicals (5-50). (69)

$$E = \frac{kg_{waste}}{kg_{product}}$$

3

Considering that pharmaceutical chemistry often includes many synthetic steps, with considerable workup, a lot of solvent is used and the efficacy of the synthesis is substantially lower than in other industries. Sheldon is a great proponent for green chemistry, the branch of chemistry that focuses on reducing or eliminating the amount of hazardous substances generated in synthesis. This has ultimately led to many environmental benefits and a strengthened economy as a more sustainable industry has been developed. (70) Sustainability is the main focus of green chemistry and might be most aptly put in the words of the *Our Common Future* report, known as the *Brundtland Report*, from the UN World Commission on Environment and Development. "Sustainable development is development that meets the needs of the present without compromising the ability of future generations to meet their own needs." (71) Aiming at this goal, there are twelve main steps to consider in a synthetic procedure, amongst them; the number of steps, solvents used, less hazardous chemicals involved, energy efficiency and catalytic vs. stoichiometric. (72) A great example of improving and optimizing pharmaceutical syntheses with a focus on environment can be seen in the synthesis of sildenafil citrate, the active compound in Viagra, marketed by Pfizer. The vast improvement is shown in Figure 22 below. (73)

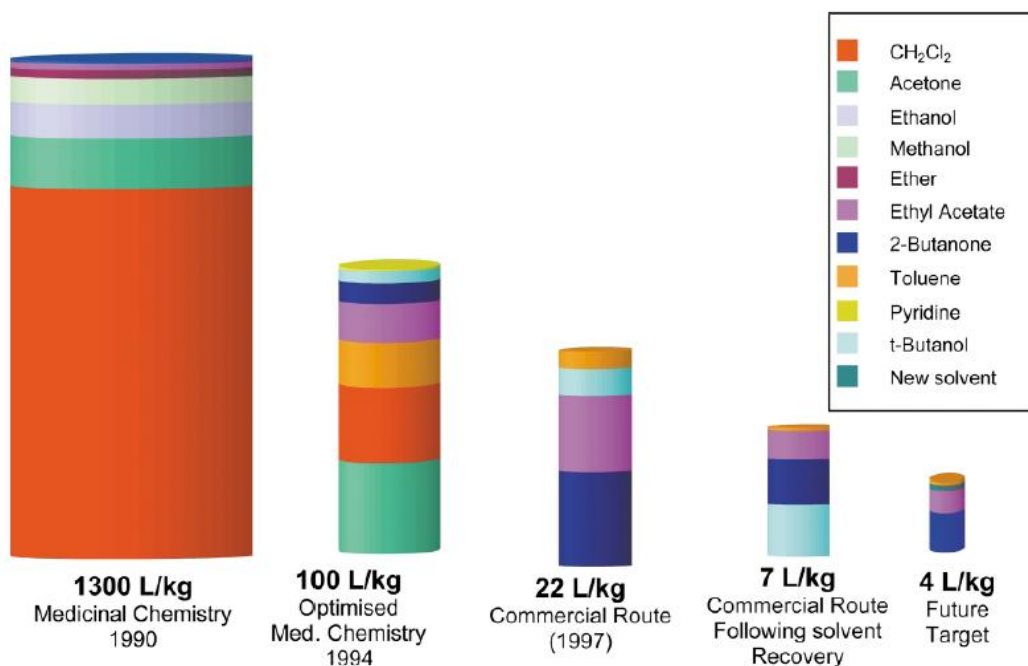

Figure 22: Waste produced in the synthesis of sildenafil citrate at various times. (73)

Theory

Even though this thesis does not explicitly aim to lower the E factor of the production of levosalbutamol, the intentions are the same.

As mentioned, the price of racemic salbutamol can be up to five times that of levosalbutamol. Although the diastomer of salbutamol has not been proven to have any significant detrimental effects, making improvements in the synthesis of levosalbutamol may shift the cost effectiveness of the synthetic route in the favour of levosalbutamol. By improving the synthesis, using less solvent, water when possible, reducing the amount of synthetic steps, and using biocatalysts (milder conditions), the E factor could hopefully be improved to the same degree as for Viagra, leading to an ultimately greener synthetic route.

2.3.1 Biocatalysis

Records of biocatalysis as old as 400-500 B.C. has been found in Mesopotamia. These records were themselves copies of several thousands of years old records. They outline what is probably the most common chemical reaction known to man. They explain how grains were fermented in order to yield beer, the process known as brewing. (74) Although not a stereoselective reaction, it implies the importance of biocatalysis in chemistry. Incidentally, yeast is a very common biocatalyst and can be used in a wide variety of ways within organic synthesis. (75-78)

There are several reasons as to why biocatalysts are a huge asset to organic synthesis. First and foremost, they are incredibly effective catalysts that can work under very mild conditions. Due to the nature of enzymes, they are most efficient at physiological conditions, meaning low temperatures and neutral pH. Chemical compounds are usually stable at these conditions, which reduces the risk of decomposition. Several enzymes can be used in the reaction, allowing for complex one-pot reactions, and by designing the reaction properly a lot of the workup usually required can be avoided. This can be done removing the need for other reagents, vastly reducing the amount of solvent needed and reducing the amount of byproduct. Enzymes are not restricted to their natural substrate, and just as non-natural substrates, such as agonists and antagonists, can interact with the active sites of receptors, enzymes have a high tolerance of a large variety of substrates. Due to the large diversity of enzymes found in nature, the range of reactions that can be catalyzed, and their substrate tolerance, there is virtually no limit to the capabilities of enzymatic reactions. Different enzymes have different selectivities, and choosing the right enzyme can catalyze the reaction based on the functional group (chemoselective); the same functional groups, but in different environments (regioselective);

2.3 Synthetic route

or based on the chirality, be it only reacting on one enantiomer or only synthesizing one enantiomer from a prochiral substrate (enantioselective). As catalysts, they can be washed and reused making them an economical choice being biological, they are biodegradable and easily disposed. (9)

The experimental procedure chosen is influenced by several factors, most importantly the type of reaction wanted. The six main classes of enzymes are listed in Table 1, with the type of reaction related to each class.

Table 1: The different classes of enzymes, and their related reactions. (9)

<i>Enzyme class</i>	<i>Reaction type</i>
Oxidoreductases	Oxidation-reduction
Transferases	Transfer of functional groups
Hydrolases	Hydrolysis
Lyases	Addition-elimination
Isomerases	Isomerizations; racemization, epimerization, rearrangement.
Ligases	Formation-cleavage of bonds with carbon.

Most commonly used are the hydrolases for their ability to hydrolyze esters, amides and lactones. A subgroup of hydrolases are the lipases mentioned previously. The advantage when using hydrolases is that they do not require any cofactors and can be readily used as isolated enzymes. In addition, they are not selective towards specific substrates, but the functional group. This makes them viable for a wide range of reactions. (9)

The second most common class of enzymes used are the oxidoreductases. The major and most important difference between these two classes is that oxidoreductases require a redox cofactor that can act as a redox counterpart to the substrate. These redox cofactors are often expensive and are recycled using other enzymes in order to use them in catalytic amounts, shown in Figure 23. To completely remove the need for these cofactors, whole cells are often used. As the biological cells have a closed system, they have redox cofactors in their cytoplasm, in addition to a method of recycling them. As a result, the only reagent needed when using whole cells as biocatalysts, apart from the cells and the substrate, is a source of energy, often glucose or a growth medium. The disadvantages of using whole cells are that there might be several competing enzymes in the organism, or the substrate might be toxic to the cells in the concentrations usually used. In addition, the presence of the substantial biomass may cause the workup to be cumbersome and might result in low overall yields. (9)

Theory

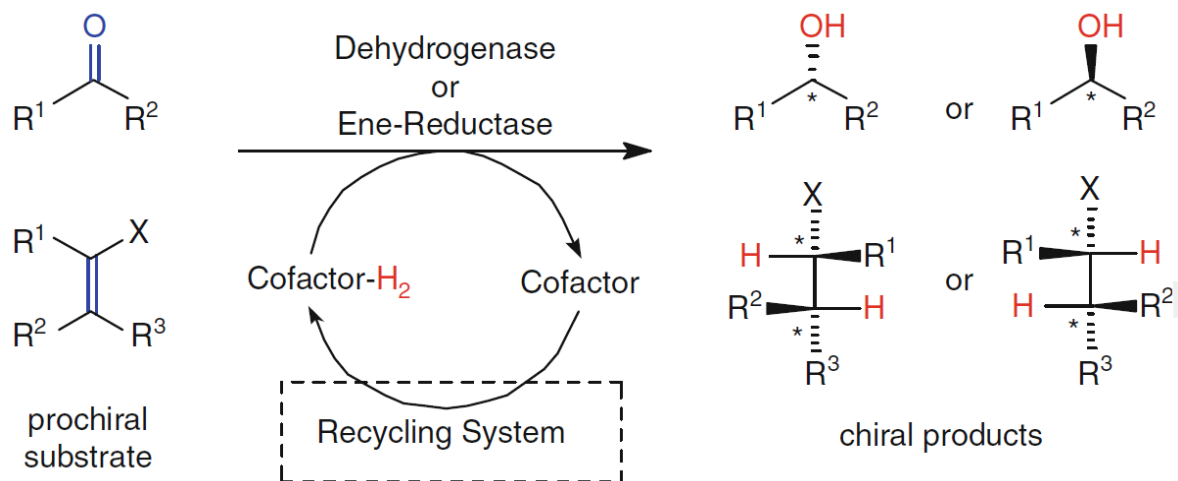

Figure 23: Example showing how enzymes require recycling of cofactors. (9)

After finding an enzyme with the wanted selectivities, the two main options are isolated enzymes or whole cells. The whole cells can come from bacteria, fungi or yeast. If the substrate is added to cells in a growth medium, the cells are considered to be growing cells, but if the cells are centrifuged and washed with water or a suitable buffer, they are considered resting cells. (79)

Biocatalysis has become more common in industrial processes and is for example used in washing powder, to enable the removal of grease stains at lower temperatures. Other industrial uses would be in animal food, textile production and paper production. (80) For industrial purposes, biocatalysts can be superior to chemical catalysts both in terms of being environmentally friendly and more cost effective, economically speaking. (9)

2.3.2 Current approach

In the 1970s, several patents were taken out on different syntheses of salbutamol. Common for most of them is that they used a reducing agent, usually LiAlH₄, and/or palladium catalyzed hydrogenation. Reported yields were overall low, at 49 %. (81)

In 1988, Babad *et al* published a new synthetic route (Scheme 5) that bypassed several of the issues presented in the previous syntheses. For example boron reagents were no longer used, eliminating the possibility of boron contamination. This synthesis did not require any protective groups, which spares the synthesis any protection-deprotection steps. The first step had a yield of 70 % using bromine as the halide, and 40 % when using chloride. The overall yield was 43 %. (82)

2.3 Synthetic route

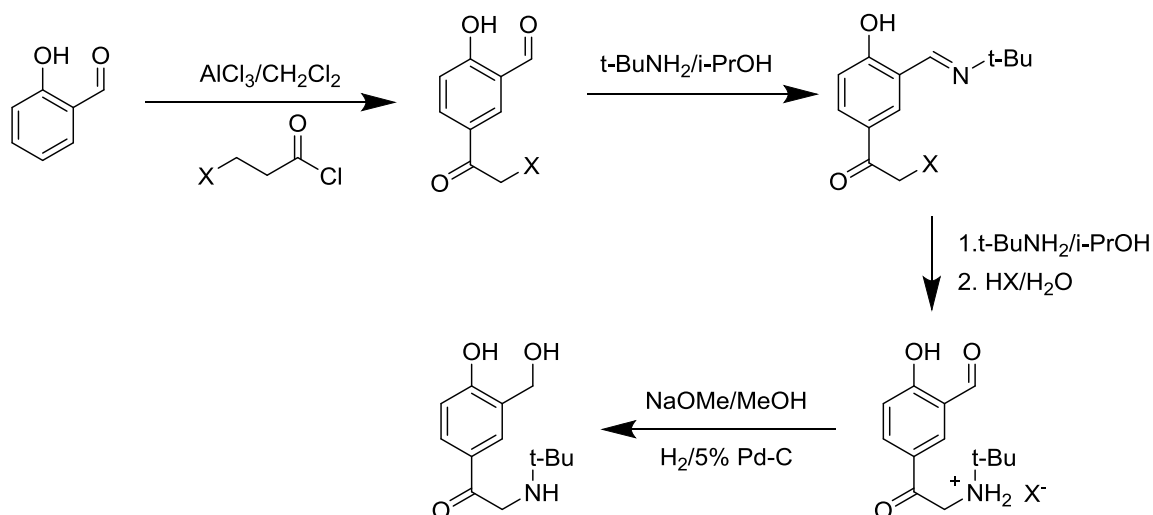

Scheme 5: Synthesis of salbutamol as published by Babad et al. (82)

As it is well established that the *R*-enantiomer is the eutomer, there are also several methods to synthesize levosalbutamol. Attempts have been made to resolve albuterol using chiral acids; dibenzoyltartartic acid (DBTA), and ditoluoyltartaric acid (DTTA), but yields were low and ee was variable. (From 32.5 % yield and 98.4 % ee, to 50 % yield and 83.5 % ee.) (83) Other chiral catalysts have been tried, such as BMS. (58) The first synthetic steps are similar in many synthetic routes for β_2 AR agonists, and a chiral reduction, similar to those mentioned, have been done with BMS for salmeterol (84) and the rhodium catalyst, Rh(Cp)Cl₂, PEG-BsDPEN for salmeterol (60) and formoterol (85).

A new patent published in February 2015 has gone a synthetic route similar to that of this thesis. The main difference being that they have chosen to reduce the ketone group with KBH₄. Achieving a promising total yield of 80 % from start to finish proves that the approach chosen is potentially suitable for industrial use. Choosing the borohydride reducing agent prevents the stereoselective synthesis of levosalbutamol that would have been achieved with a chiral catalyst. They have also chosen to aminate the α -bromine before the reduction. This is not advisable with the biocatalysts chosen in this thesis, as the *t*-butyl amine group would become far bulkier than preferred for the active sites in the enzymes. In addition, this was not synthesis of levosalbutamol, but rather racemic salbutamol and would require an additional step to resolve the enantiomers. (86)

As shown, many of the current syntheses use metal catalysts and as mentioned, they are often expensive. Switching out the metal catalysts used in the current synthesis of levosalbutamol with a biocatalyst could be a tremendous improvement (69) and even though it has been 12

Theory

years since Skjærpe's thesis was written, any attempts of synthesizing levosalbutamol using a biocatalytic approach has yet to be published.

2.3.3 Own approach

When deciding on how to begin the synthetic route to synthesizing levosalbutamol, it was mentioned in Section 1 that the master's thesis from 2003 by Camilla Skjærpe was used as a basis. In the section called "Further progress" of Skjærpe's thesis, she suggests following the synthetic route shown in Scheme 6. (1)

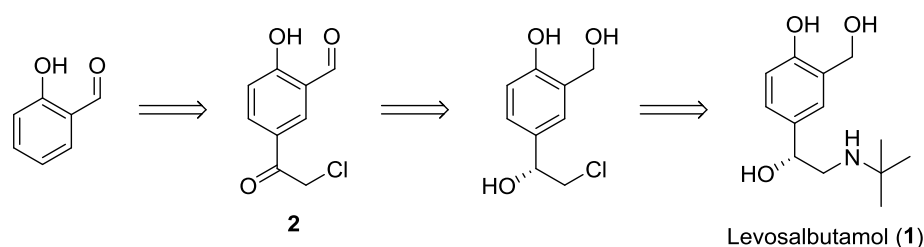

Scheme 6: Synthetic route suggested by Camilla Skjærpe. (1)

The initial step of the synthesis was taken from Babad *et al* (82), and was chosen due to the availability of salicylaldehyde and the simplicity of the reaction, as Friedel-Crafts acylations are one of the staple reactions in organic synthesis. After the Friedel-Crafts acylation, there were two main options. The first was to reduce the secondary ketone using a chemical reducing agent, followed by an enzymatic resolution, and the second option was to use a biocatalyst to reduce the ketone asymmetrically. Skjærpe tried both methods, where reducing the ketone enzymatically, using growing *S. cerevisiae* gave variable results (0 % to 25 %), and the chemical reducing agents gave no results. Further progress was not made by Skjærpe.

2.3.3.1 Friedel-Crafts Acylation

Friedel-Crafts (FC) reactions are common reactions used to create carbon-carbon bonds with aromatic rings. There are two different FC reactions, alkylation and acylation. Most common are the reactions done with alkylhalides, and acyl halides, respectively. The general method is outlined in Scheme 7 below. Alkylations are very straightforward reactions, attaching an alkyl chain to the aromatic ring, while acylations attaches acyl chains. These types of reactions are called electrophilic substitution reactions. The reagents are given a positive dipole by a Lewis acid, causing the electrons from the aromatic ring to react. Subsequently, the hydrogen present on the aromatic ring leaves. The total reaction is a substitution of the hydrogen with the wanted reactant. The reagent aluminum chloride (AlCl_3) seen in Scheme 7, is a very strong Lewis acid used to give the chain a positive dipole to start the reaction. Unfortunately, AlCl_3

2.3 Synthetic route

is used in stoichiometric amounts, resulting in metal waste that needs to be disposed of. (3, 8, 87)

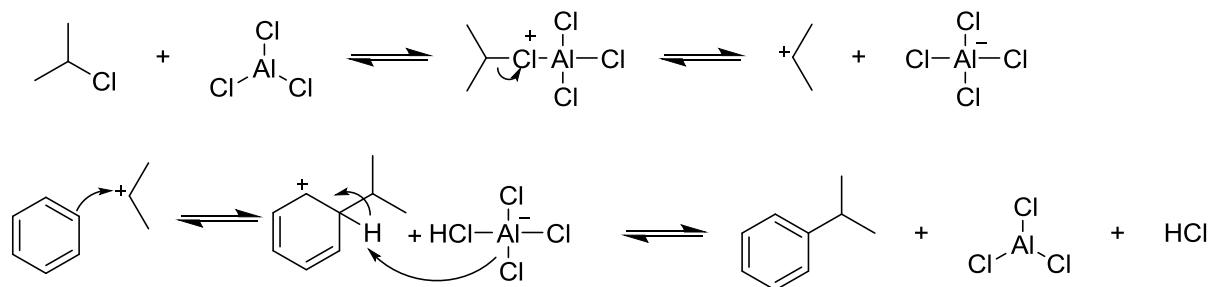

Scheme 7: Mechanism for a Friedel-Crafts alkylation. (3)

Although of great use, the FC reactions have some issues. The FC alkylations have a tendency to become polyalkylations, where several reagent molecules attach to the aromatic ring. Another issue with FC alkylations is that if a longer alkyl chain is used, they tend to rearrange when forming the carbocation. This makes it important to be very selective with the reagent used. Neither of these issues are very problematic with FC acylations. The reason for this is that the carbocation formed is stabilized by the neighboring carbonyl group, and polyacylations are not a problem due to the electron withdrawing effect of the electron withdrawing group, an effect that will be explained in the next paragraph. If the carbonyl group is unwanted the acyl chain can be reduced to an alkyl chain with a zinc catalyst in a reaction called the Clemmensen reduction. (3)

FC reactions are very sensitive to electron withdrawing (EWG) and electron rich groups (ERG). This is due to the stability of the aromatic ring. If the aromatic ring is to react, ERG can stabilize and sustain the aromaticity while the ring acts as a nucleophile to the reagents. EWG on the other hand, will draw electrons out of the aromatic system and destabilize the aromaticity. It is due to these effects that acylations only occur once, as the first acyl group will deactivate the ring system and prevent it from reacting further. Therefore, aromatic rings with ERG will react much faster than aromatic rings with EWG. Another important aspect of the ERG and EWG is that they direct the reaction. This is caused by the resonance structures and the delocalization of electrons. The activating ERG will supply the aromatic ring with electrons and resonance structures will direct the FC reactions towards the ortho or para position. The deactivating EWG will pull electrons out of the system and the aromatic ring and the FC reaction will be directed towards the meta position. (3, 8) The starting reagent used in this thesis, salicylaldehyde (Figure 24), has two groups. The alcohol group is an ERG and will activate the system and direct towards *ortho* (Position 1) or *para* (Position 3). The aldehyde

Theory

group is an EWG and will deactivate and direct towards the meta position (Position 1 or 3). The activating groups tend to have priority when directing the reagent and in this case, that would be position 1 or 3 in Figure 24. In addition to being heavily influenced by ERG and EWG, steric hindrance also play an important part during the mechanism. So the ERG would direct the reaction towards position 1 or 3, but the steric hindrance in position 1 would make position 3 the most likely reaction site, which is the wanted position for the target molecule. (8)

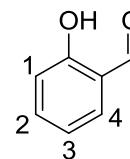

Figure 24: Salicylaldehyde.

Although the length of the carbon chain wanted on the salicylaldehyde is short enough to use FC alkylation, the carbonyl group necessary in a FC acylation is an ideal target for enzymatic reduction. Generally, secondary ketones attached to a benzene ring are called acetophenones and they are common substrates in enzymatic synthesis. (88) As a result, the FC acylation is ideal in preparation for following enzymatic use.

Because the Lewis acids used to activate FC reactions are commonly metals used in stoichiometric amounts, a large amount of harmful waste is produced. This is an area more than ready for an improvement and a lot of effort is made to find reagents that show satisfactory catalytic activity. These catalysts are sometimes named "True catalytic Lewis acids". (69, 89) Another alternative would be more environmentally friendly non-metallic reagents. An example of this, could be the use of methanesulfonyl anhydride (MSAA) as a reagent, creating a bond between an aromatic ring and a carboxylic acid. MSAA is readily available in nature, and the method has given high yields. (90)

2.3.3.2 Carbonyl reduction

As mentioned in Section 2.1.2, there are several routes towards an enantiomerically pure product. As biocatalysis is the main focus of this thesis, two options were considered. The first option was to reduce the carbonyl group using a chemical reducing agent, followed by enzymatic resolution. The second option was to reduce the carbonyl asymmetrically using enzymes. The product of the FC acylation would be an ideal substrate for enzymatic use and as mentioned, the acetophenone structure is very common in biocatalytic synthesis. As such, there is a lot of published literature on similarly structured molecules. The availability of published work on acetophenones makes it easier to find enzymes with a suitable selectivity. (10, 19, 88, 91-96)

2.3 Synthetic route

2.3.3.2.1 Reducing agent: Lithium aluminum hydride

When deciding on a chemical reducing agent the options are relatively straightforward. The two most commonly used reducing agents are lithium aluminum hydride (LiAlH_4) and sodium borohydride (NaBH_4). The difference between them are related to their strength as Lewis acids and as lithium is a stronger Lewis acid than sodium, and AlH_4^- is a more reactive is the more reactive hydride donor, LiAlH_4 is the stronger reducing agent of the two. They have similar selectivity, both readily reducing ketones and aldehydes to alcohols, but due to the higher strength of LiAlH_4 , it also reduces esters. Neither of them can reduce carbon-carbon double bonds. They should be able to react stoichiometrically, and as they both have four hydrogens, the ratio to the substrate should be 4:1. Due to the high reactivity of LiAlH_4 , it must be used in anhydrous solvents such as tetrahydrofuran or ether, as it reacts violently with water. NaBH_4 , on the other hand, may be used in both water and alcohol. (87) An interesting use of NaBH_4 has been reported using a ball mill to grind the reagent with NaBH_4 , without the use of solvents. The yields reported were all >99 % and reactions could be both stereo- and regiospecific. The downside of this method is that it requires a ball mill, which is an expensive and highly specialized piece of equipment, with a low capacity. (97)

When choosing between the two reducing agents, LiAlH_4 was chosen, as Skjærpe was not able to reduce the ketone using either of the reducing agents. Therefore, the stronger of the two agents were chosen in an attempt to improve the method and manage to synthesize the desired product. However, when comparing to other published articles involving similar reductions it seems that the NaBH_4 is preferred.(60, 84, 98).

2.3.3.2.2 Bacterial reduction: *L. kefir* and *R. erythropolis*

Due to the abundance of hydrolases that reduces acetophenones selectively, the task was undertaken to find an alternative to the baker's yeast suggested by Skjærpe. A large number of suitable enzymes were found, amongst them *Synechococcus* sp (99), *Bacillus* sp (94) and *Rhodococcus erythropolis* (100, 101). Conforming to the objective of the thesis, whole cells were chosen, due to several factors, the main reason being that it is less expensive concerning cofactors and that workup is significantly easier.

Gröger *et al.* had very promising results when using recombinant techniques to overexpress the hydrolases alcohol dehydrogenase (ADH) and glucose dehydrogenase (GDH) in *Escherichia coli*. This technique allowed them to make the *E. coli* selectively produce both the enzyme and the coenzyme required to reduce the substrate and recycle the cofactor. They ex-

Theory

pressed ADH from two different organisms in two separate sets of *E. coli*. The first having ADH from *R. erythropolis* and the other from *Lactobacillus kefir*. (101)

An important factor to keep in mind when working with enzymes is the nomenclature might not always be very intuitive. In the Cahn-Ingold-Prelog system, chemists denote the chiral centers R or S based on the atomic mass of the atoms around the chiral center, while biochemists often use Prelog or Anti-Prelog, based on size. In the case for the FC acylation product, the bromine atom makes the desired product the *R*-enantiomer, and the size makes it Prelog. Had this bromine been changed with a methyl group, the desired enantiomer would have been *S*, while the size stays the same and it would still be Prelog. (9) As the active sites are unaffected by atom mass, and only take size into consideration, the R and S prefix is somewhat irrelevant compared to Prelog and Anti-Prelog. In the asymmetric reduction wanted for levosalbutamol, the Prelog selectivity is desired. Gröger *et al.* reported *L. kefir* as being *R*-selective, but due to the methyl group this would be Anti-Prelog, while *R. erythropolis* would be *S*-selective and Prelog. This illustrates the importance of considering the stereoselectivity in terms of both Prelog/Anti-Prelog and R/S, when searching for a suitable enzyme for the synthesis.

2.3.3.2.3 Yeast reduction: *S. cerevisiae*

Baker's yeast, *Saccharomyces cerevisiae*, is the most commonly used biocatalyst for asymmetric reduction of ketones and the ADH is very stereoselective, always reducing according to Prelog's rule. (9) Amongst the reasons for Baker's yeast's wide spread use, is its simplicity, affordability and broad substrate selectivity. Baker's yeast can be used to reduce ketones with a great diversity of functional groups around it, including heterocyclic- fluoro-, chloro-, bromo-, cyano-, and nitro groups. (9)

A reason for its selectivity can be seen below in Figure 25. The ADH in Baker's yeast has a small pocket in which the substrate fits. Keeping the larger regions outside of the pocket prevents the yeast from being too selective, as there is no need to accommodate the larger substituent. Yeast is highly suitable for this synthesis, for many reasons. The affordability allows it to be used on a large scale, (77, 78) without costs being too high, in addition to the fact that *S. cerevisiae* has been shown to effectively reduce α -halohydrins, compounds similar in structure to the substrate used in this thesis. (19)

2.4 Analytic methods for analyzing chiral molecules

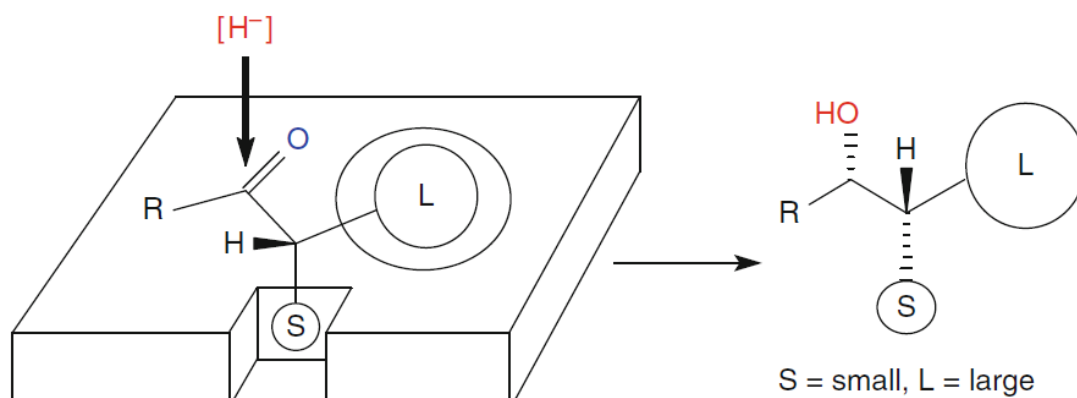

Figure 25: Model for predicting the stereoselectivity of yeast. (9)

The downside of using whole cell Baker's yeast is that being a living cell, it contains many enzymes and some of the enzymes might compete for the substrate. This may result in unwanted byproducts. (9)

2.4 Analytic methods for analyzing chiral molecules

As mentioned previously, enantiomers have the same physical and chemical properties and cannot be differentiated by conventional means. The only way to separate enantiomers or analyze the difference between them is to let them interact with other chiral substances. In this section, two analytical methods used to analyze chiral molecules will be explained: chiral high performance liquid chromatography (HPLC) and polarimetry.

2.4.1 Chiral High Performance Liquid Chromatography

Chromatography is a common technique commonly used in chemistry. The principle of chromatography is, simply put, the separation of chemical compounds based on differences in properties. To do this, chemical compounds in a mixture are physically separated by moving through a stationary phase in a mobile phase. By choosing appropriate phases, the compounds will have different affinities to the mobile phase. If a compound has a high affinity to the mobile phase, it will move quickly through the stationary phase and will therefore eluate quickly, while compounds with a higher affinity to the stationary phase will spend more time in the stationary phase, thus having a higher retention and will, as a result, eluate slower. The time taken to eluate is called the retention time, and is denoted t_R .

There are many different types of chromatography, usually based on the physical states of the phases used for the mobile and stationary phases. In this thesis, the mobile phase used was liquid, while the stationary phase was solid, and the separation was based on adsorption to the

Theory

stationary phase. This is called liquid-solid chromatography (LSC). Modern liquid chromatography uses high-pressure pumps to keep a stable flow, and accurate on-line detectors, and is called high performance liquid chromatography (HPLC). (102)

Stationary phases are usually solid materials inside a rigid tube, called a column. Different solid materials in the columns are chosen in order to specify by which properties the compounds should be separated. Separation of compounds can be based on the size of the compounds if the stationary phase has pores of a specific size. This is called size exclusion chromatography (SEC). Usually, separation is based on polarity and the stationary phases chosen are polar silica derivatives. However, as mentioned, enantiomers have the same physical and chemical properties and normal chromatographic techniques are not able to separate enantiomers. Chiral molecules are indistinguishable, except when they interact with other chiral substances, and in order to separate enantiomers using chromatographic techniques, the packing material in the column must be chiral. The packing material chosen for chiral HPLC is usually derived from natural sources, such as amino acids, cyclic saccharides, polysaccharides or proteins. Figure 26 is an example of this, with the packing material being derived from amylose. This is the packing material used in the Chiralcel ODH columns used in this thesis. (102)

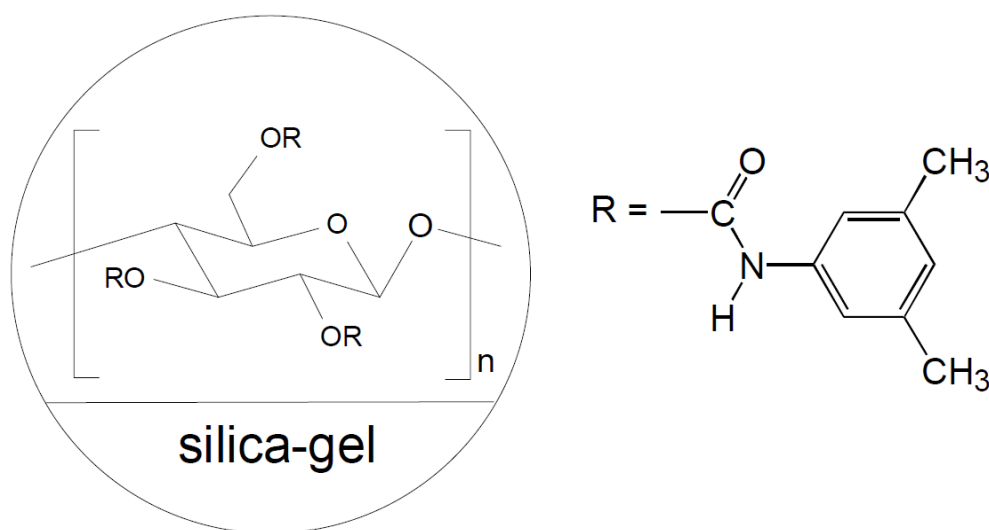

Figure 26: Packing material in a chiral HPLC column, Chiralcel OD-H.

In chiral chromatography, the separation is based on the interaction between the enantiomers and the chiral section of the packing material. As the enantiomers have a different spatial configuration, they interact differently with the chiral selectors in the column. These effects make it possible to separate enantiomers. (102)

2.4 Analytic methods for analyzing chiral molecules

2.4.2 Polarimetry

As opposed to chiral HPLC, polarimetry is a method to find a property shown by chiral molecules, namely the optical rotation. Optical rotation is a measurement of how much the compound rotates plane-polarized light. The optical rotation is a property that is not found in achiral or racemic mixtures, but enantiomers have specific values that can be used for identification as any other physical property, such as melting point or boiling point. In order to measure the optical rotation of an enantiomer, an instrument called a polarimeter is used. (3)

The principle of a polarimeter is simple (Figure 27). A light source, usually a sodium lamp, shines light through a polarizer. The polarizer causes the light to oscillate only in one plane, as opposed to normal light that has two oscillating, perpendicular waves. The light is sent through a sample cell, reaching an analyzer in the other end. The analyzer is another polarizer that can be rotated, attached to a fixed degree scale. The analyzer is rotated until the maximum intensity of light shines through. If the sample contains an achiral substance or a racemic mixture, the analyzer does not need to be rotated, and the rotation measured, α , is 0° . (3)

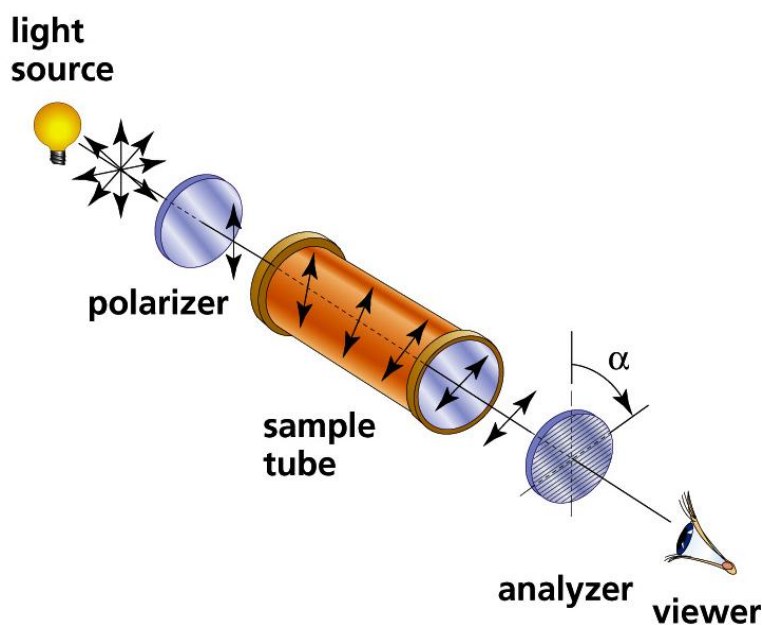

Figure 27: The concept of a polarimeter.

When the sample cell contains a single enantiomer of a compound, the analyzer is rotated either clockwise (+), or counterclockwise (-) to find the angle of maximum light intensity. The amount of rotation is dependent on the amount of enantiomers the light travels through, which depends on both the travel length through the sample, and the concentration of the molecules in the sample. To account for this, the specific rotation of an enantiomer is calcu-

Theory

lated using Equation 4 below, where $[\alpha]_{\lambda}$ is the specific rotation, α is the measured rotation, c is the concentration in g/100 ml, and l is the length of the sample tube. (3)

$$[\alpha]_{\lambda} = \frac{\alpha}{c \cdot l} \quad 4$$

A set of enantiomers will have an equal, but opposite specific rotation of each other. The different enantiomers of salbutamol has been resolved by crystallization with tartaric acid and the *R*-enantiomer was found to have $[\alpha]_{\lambda} = -36.9^{\circ}$ and the *S*-enantiomer $[\alpha]_{\lambda} = +36.9^{\circ}$ when dissolved in water. The rotation of an enantiomer may differ in different solvents, so when comparing measured rotations to literature values it is important to use the same solvent. (81)

3 Results and Discussion

3.1 Synthetic approach

3.1.1 Synthesis of 5-(2-chloroacetyl)-2-hydroxy-benzaldehyde (**2**)

The synthesis of **2** was done according to the procedure described by Babad (82) and Skjærpe (1), and had a yield of 17.3 %.

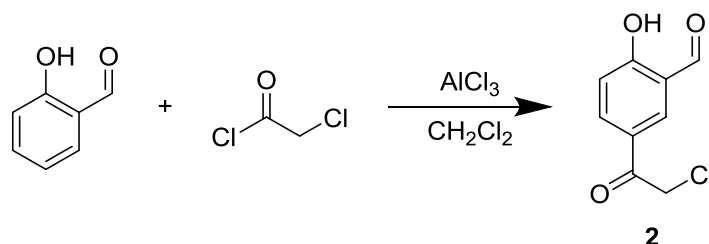

Scheme 8: Friedel-Crafts acylation of salicylaldehyde to form **2**

During quenching, when pouring the reaction mixture into water at 0 °C, fumes formed and flash boiling occurred, resulting in the loss of product. Although visible quantities of product were lost, it was not enough to explain the significantly low yield.

The same low yield was also observed in Babad's work, as well as Skjærpe and Henriksen (103). It is possible that the electron-withdrawing effect of the aldehyde group is too powerful for the reaction to achieve a satisfying yield, as Friedel-Crafts acylations are known to be highly sensitive to EWG. (3) Despite the low yield, high purity was indicated by MS (Spectrum 1).

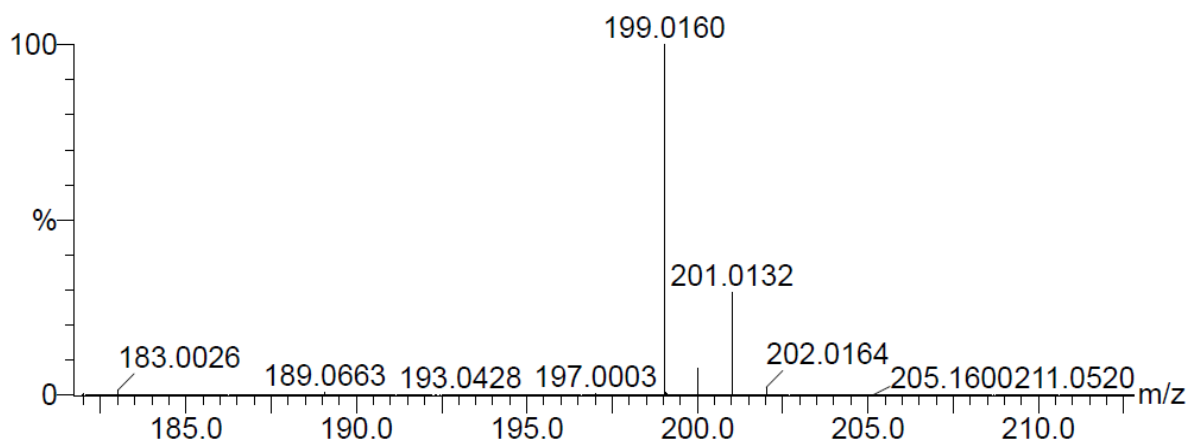

Spectrum 1: Mass spectrum of **2**.

Results and Discussion

The unsatisfactory yields raise the question of the efficacy of this specific synthesis, specifically the use of chloroacetyl chloride since both Babad and Henriksen reported higher yields when bromoacetyl chloride was used instead. It is unsure why Skjærpe chose to use chloroacetyl chloride, but further use was disregarded, as the higher yield from the bromoacetyl chloride is much preferred.

3.1.2 Synthesis of 5-(2-bromoacetyl)-2-hydroxy-benzaldehyde (**3**)

The synthesis of **3** was done based on the procedure described by Henriksen, which was based on Babad, and had a yield of 34.9 %.

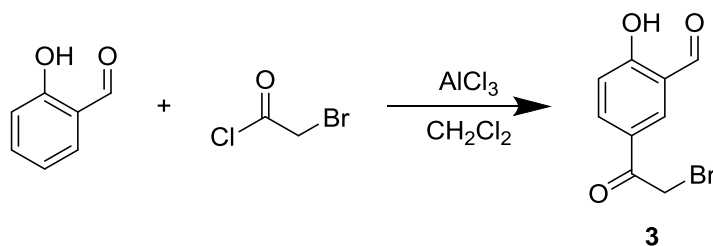

Scheme 9: Friedel-Crafts acylation of salicylaldehyde to form **3**

Preventable spillage was also present during this procedure, as unexpected flash boiling caused some of the limiting reagent to escape the flask during addition. The procedures describing this method usually say "pour carefully", but the volatility of the solution was vastly understated.

In addition, this reaction had a high degree of purity shown by its MS spectrum (Spectrum 2), HPLC chromatogram (Figure 28) and NMR spectrum (Spectrum 3). The chemical shifts of the protons are shown in Table 2 and are used to identify the positions of the protons shown in Spectrum 3. The chemical shifts of the protons are consistent with literary values. (82)

3.1 Synthetic approach

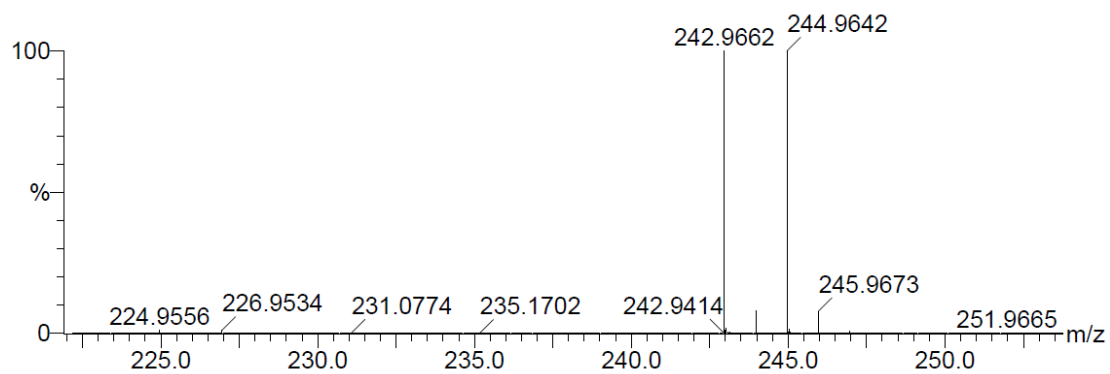

Spectrum 2: Mass spectrum of **3**

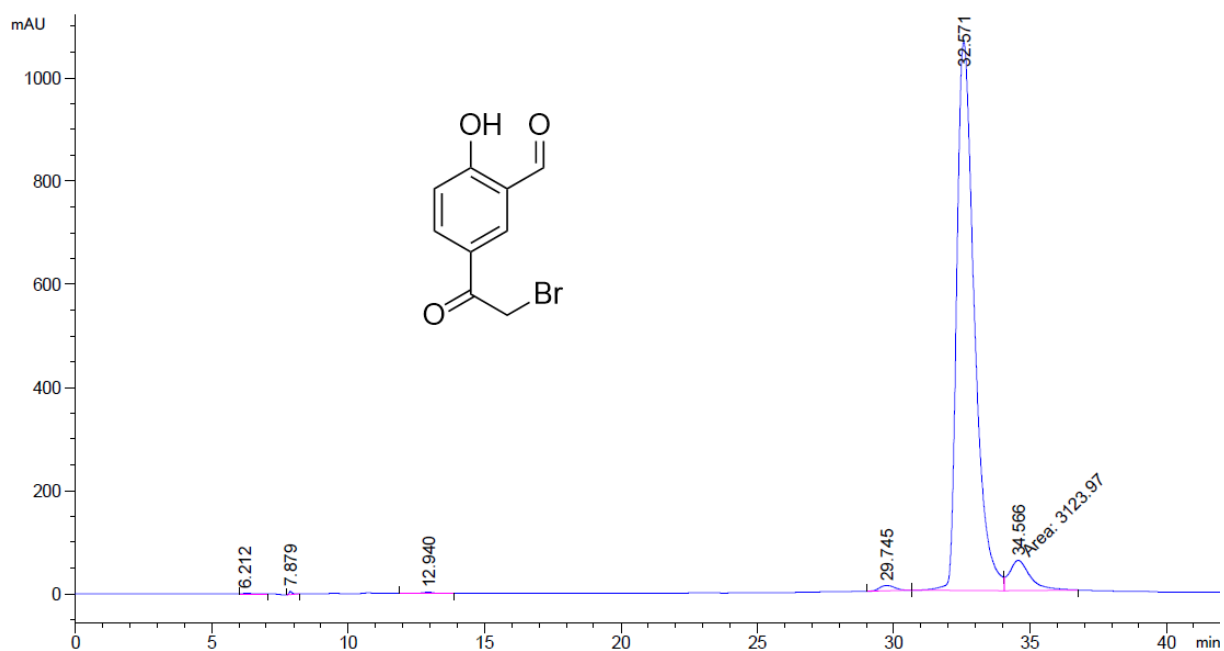
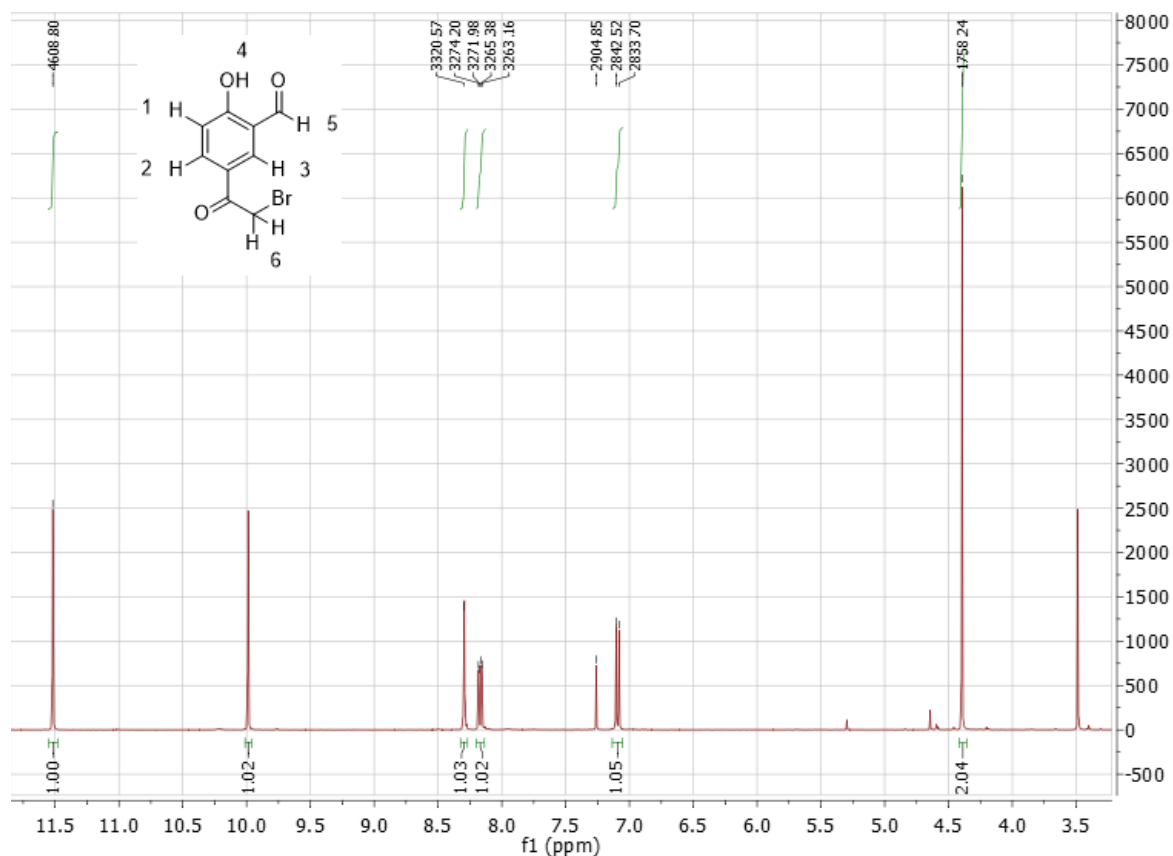

Figure 28: HPLC chromatogram showing the retention of **3**

Results and Discussion



Spectrum 3: NMR spectrum of **3** in CDCl_3

Table 2: Chemical shifts of protons in **3**

Position	Observed ppm	Splitting	Coupling [Hz]
1	8.3	Doublet	J=2.3
2	8.2	Double doublet	J=2.3 J=8.8
3	7.1	Doublet	J=8.8
4	11.5	Singlet	
5	10.0	Singlet	
6	4.4	Singlet	

In a second attempt to do this procedure, water was added dropwise to the solution. This seemed successful, but the solution should have been stirred more vigorously as a solid precipitate formed on top resulting in slower quench than wanted. The solid formed was most likely AlCl_3 reacting with water to form aluminum hydroxide ($\text{Al}(\text{OH})_3$), following the reac-

3.1 Synthetic approach

tion pictured in Equation 5 below. (104) The intermediate stages may have been insoluble, creating a lid on top of the reaction solution. A slurry was also formed for Henriksen, causing issues with the workup.

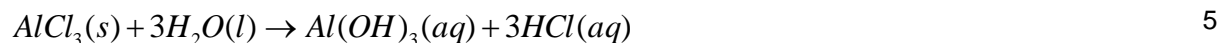

This second attempt gave a very low yield of 10 %, as the product from the first recrystallization decomposed while drying. The product was dried at approximately 80 °C, which should be sufficiently within the theoretical melting point of 117-118 °C. (105) The only product left was that of the second recrystallization, which is less pure and was not purified or analyzed further.

Even though the synthesis of **3** had a higher yield than that of **2**, the same synthesis has been reported several times in literature with a yield of 70-80 %. (60, 82, 98) This shows that there is a lot of room for improvement in this step, and that both the technique and method itself should be improved.

A suggestion as to why bromoacetyl chloride serves as a better acylating agent could be that chlorine is more electronegative than bromine. In this case, the acylated bonded to the aromatic ring would be more electron withdrawing if the halide is more electronegative. Following this train of thought might lead one to believe that iodoacetyl chloride might have been even better than bromoacetyl chloride, but this would most likely cause more problems in the enzymatic step, as iodine is significantly larger than bromine. This could make the substrate too large for the active site of the enzyme, shown previously in Figure 25.

A possible solution, that would bypass many of the issues faced during this synthetic step, could be to use MSAA and bromoacetic acid. (90) Keeping up with the spirit of this thesis, this would provide a greener synthesis using reagents friendlier to the environment. Using acids to catalyze Friedel-Crafts acylations are relatively common. (8, 87) Although the general reaction provided by Wilkinson combines an aromatic ring with an aromatic acid, the fact that acid catalyzed Friedel-Crafts acylations are fairly common (87) suggests that this could be a possible replacement for the $AlCl_3$ catalyzed reactions. Not only is the MSAA derivable from biomass, the extensive use of halides is avoided. This could also simplify the workup.

Results and Discussion

3.1.3 Synthesis of 4-(2-bromo-1-hydroxyethyl)-2-(hydroxymethyl)phenol (**4**) with LiAlH_4

This synthesis was based on the procedure done by Skjærpe and resulted in a yield of 66 %, although this is thought to be very inaccurate the low purity indicated by the large initial peak in the HPLC chromatogram (Figure 29). There were difficulties during the purification, so the pure product was never fully isolated. As a result, the actual yield is unknown.

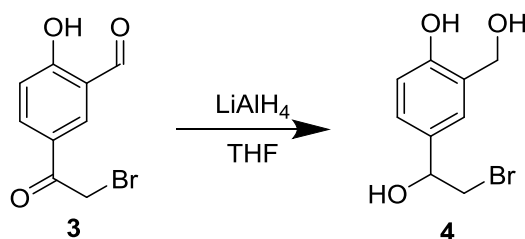

Scheme 10: Reduction of **3** with LiAlH_4 to its corresponding triol, **4**

This synthetic step was done in order to prepare a suitable substrate for enzymatic resolution. Henriksen had attempted this synthesis in advance, but had only achieved a yield of 11 %. In an attempt to improve yield, several changes were made in the procedure, including an attempt to quench the reaction mixture with diluted sulfuric acid. This was done in an attempt to protonate the aluminum complexes formed, making them ionic and thus soluble in water. This was intended to make the aluminum salts easy to remove, as this had been an issue for Henriksen, as she had difficulties during the workup of a slurry formed during the quench.

The yield was adequate (66 %), but due to the low purity, the reaction cannot be considered very successful. Since the chemical reducing agent LiAlH_4 was used the alcohol product should be racemic, which would show up as two equally large peaks in a chromatogram due to the two enantiomers. Two equal peaks were observed at $t_R=38$ and 42 min, which would suggest that the reduction itself was successful. Later, project student Sigrid Løvland attempted to reproduce the results that Henriksen had achieved, but once again the workup proved difficult and the resulting purity was low. During the workup of Løvlands product, however, two almost equal peaks appeared in the chiral HPLC chromatogram at $t_R=48.3$ and 50.2 min. The discrepancy between the retention time in the two reactions may be explained by the fact that Løvlands HPLC program was run with 0.5 ml/min flow, as opposed to 0.7 ml/min.

3.1 Synthetic approach

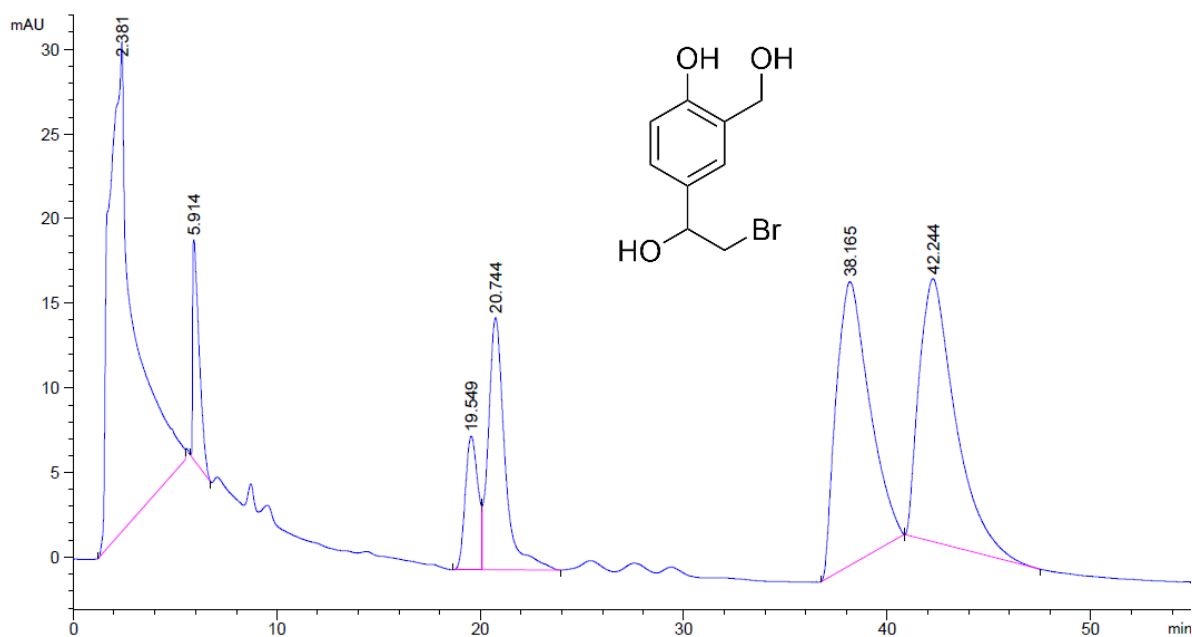

Figure 29: HPLC chromatogram showing the retention of the suspected racemic **4**.

When comparing the procedure used here with procedures found in the literature, it appears that being the stronger reagent may not have been beneficial. If NaBH_4 could be used in methanol, the workup might be considerably easier. The polarity of the triol product was a detriment to the procedure, especially since the specific structure of **4** never has been published. Due to the lack of information, very little was known about the properties of the product and how to purify it. As a result, a substantial amount of product might have been lost when changing solvents or trying to find a suitable experimental procedure.

The lack of published information and the difficulty of handling might be a coincidence, but considering the issues when working with the substance it might be that no one has managed to produce results satisfactory enough for publication. As can be seen in other publications, protective groups are often used. The most relevant exception is the latest patent, published in February 2015. They report that they have successfully reduced both the ketone and the aldehyde, using NaBH_4 in alcohol, with an 80 % yield. However, they aminated the substance before reduction, leaving **4**, drawn in Scheme 10, unpublished.

Searching for this exact structure in different databases yields no results other than as a suggested molecule for a hypothetical synthetic step in a patent from 2009. (106)

Because of the difficulties handling the product, it was chosen not to purify the product before further use. As can be seen by the chromatogram (Figure 29), the product had significant impurities which were difficult to remove. The product was kept as a solution, as it was difficult

Results and Discussion

to isolate the product, despite being filtered and attempted to be dissolved in a large range of solvents. As the amount of product in the solution was hard to quantify and suspected to be highly impure, it was further used as the impure mixture. This was due to the suspicion that further purification would reduce the amount of product down to undetectable concentrations when used during the chiral resolution in the next step.

3.1.4 Enzymatic reduction of 5-(2-bromoacetyl)-2-hydroxy-benzaldehyde (**4**) with *C. antarctica*

This procedure was done as a test to see if the substrate was suitable for chiral resolution by *Candida antarctica* lipase A (CALA).

This step was done based on information received orally from Associate professor Jacobsen, based on her previous work and experiences. The yield could not be determined due to the large amount of impurities.

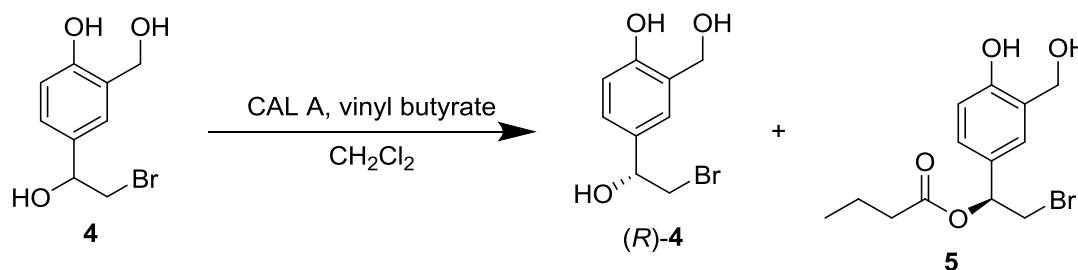

Scheme 11: Enzymatic resolution of **4** with *C. antarctica* Lipase A

After an attempt to analyze the product on HPLC, it was apparent that the substrate did not react as hoped and the product could not be positively identified. The focus was shifted over to chiral reduction, due to the fact that the preceding step gave an uncertain and probably inaccurate yield of 66 % and that this step had maximum theoretical yield of 50 %, due to the nature of chiral resolution. It was decided not to pursue this route and focus on enzymatic asymmetric reduction instead. The difficulties in handling the triol as both the substrate and the product did not seem as a feasible option on an industrial scale compared to the reagents used in the asymmetric reduction.

3.1.5 Yeast reduction of 5-(2-bromoacetyl)-2-hydroxy-benzaldehyde (**3**) with *S. cerevisiae*

This procedure was based on the procedure written for *S. cerevisiae* in "Practical Biotransformations: A Beginners Guide" (79) and the work done by Skjærpe. The product has not been fully purified and contains large amounts of impurities. The reported yield is there-

3.1 Synthetic approach

fore currently 915 %, which is clearly inaccurate and should not be considered valid data, although it is the only acquired data for the reaction yield. This was an issue with the polarity of the product, as it would not eluate from the flash column even after 7-8 days and the purification was discontinued to due time constraints.

Optical rotation of the product was measure to be $\alpha=-0.064^\circ$ in DMSO and $\alpha=0.003^\circ$ in water. Note that this was not absolute rotation, as the actual concentration of the product was unknown.

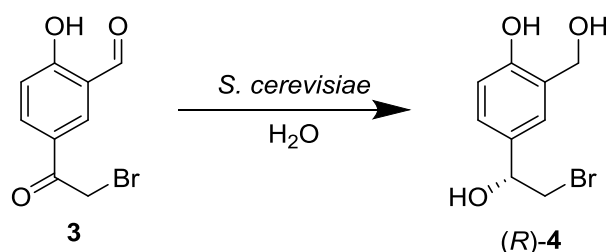

Scheme 12: Reduction of **3** to the enantiomeric *R*-alcohol, (*R*)-**4** using *S. cerevisiae*

In an attempt to optimize the reaction, 5 % v/v of *t*-butanol was added to the sugar water growth medium. This is based on Lin *et al.*, as they tried to optimize the effect of a *S. cerevisiae* strain. (19) This should increase the yield, and enantioselectivity of the enzymes compared to using pure sugar water.

During the incubation period of the reaction, preliminary results looked promising when analyzed on chiral HPLC. When a sample was taken from the reaction solution, the chromatogram seen in Figure 30 was the result. The flow was slightly lower than for the other chromatograms, being 0.5 ml/min as opposed to 0.7 ml/min, causing a slightly slower retention.

Results and Discussion

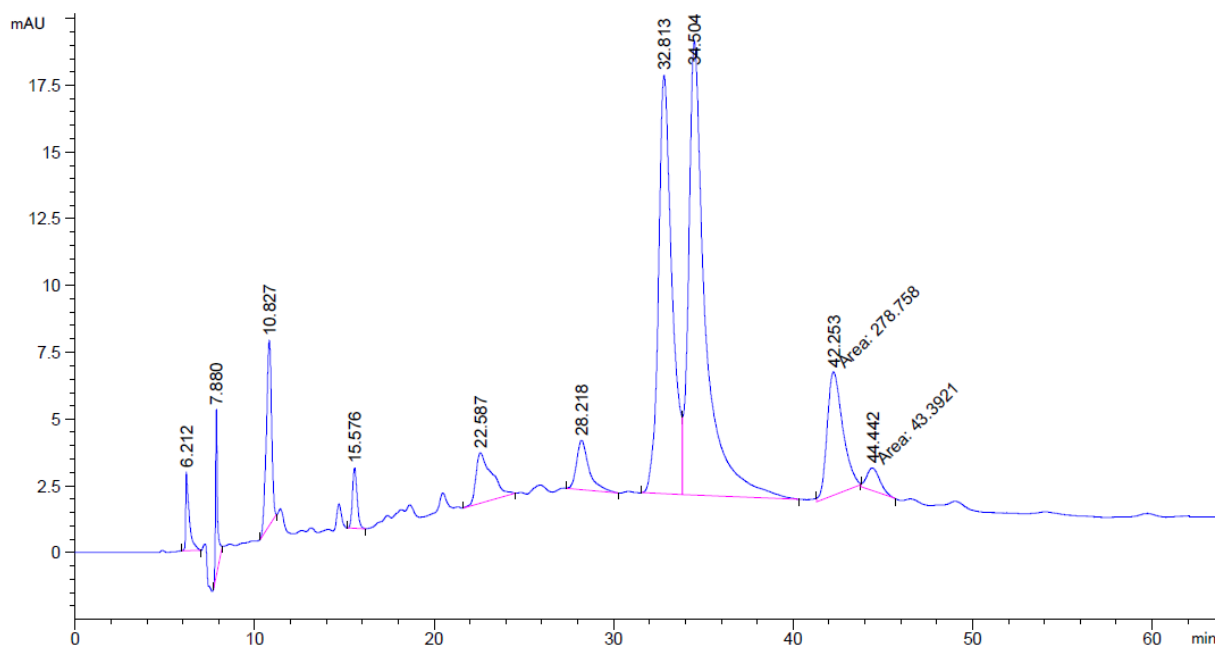

Figure 30: HPLC chromatogram of the yeast reduction after 24h.

Comparing Figure 30 to Figure 28 it seems that one of the two peaks at $t_R=32.8$ and 34.5 min is most likely the starting substrate. Further comparison with Figure 29 and Figure 32 indicates that the peaks at $t_R=42.3$ and 44.4 min might be the two enantiomers of the product produced in different amounts. The unidentified major peak at $t_R=32.5$ or 34.5 min could possibly be a monoreduced substrate where only one of the two carbonyl groups have been reduced. This would be reasonable considering the fact that the substrate would become more polar with one more hydroxyl group, thus more polar than the substrate and less polar than the product. After a few days, two of the peaks were no longer visible. This could be related to either a more complete conversion of the substrate, or the continuous addition of sugar water might have diluted the sample to such an extent that it was no longer visible. A third option could be that enzymes made unwanted by-products by breaking down the reagents.

An attempt was made to filter out the suspended yeast using a celite disk, but the filtration was extremely slow. Pressure was added using nitrogen, but when the solution was left for filtration, the suspended yeast settled out and plugged the celite disk, Figure 31, preventing filtration. The solution was then decanted instead, leaving most of the yeast behind.

When evaporating the solvents after the decantation, dark oil was formed. This was thought to be pyrolysis of the residual sugar from the reaction. Pyrolysis of the sugar may have given several compounds that could be difficult to separate from the wanted product. (107)

3.1 Synthetic approach

Depending on the pressure used to evaporate the solvent, it is also possible that the Maillard-reaction can have occurred, yielding products which would give similar problems as those created by pyrolysis. (108) Using flash chromatography to purify the product before drying might have avoided the problem, although the amount of solvent might cause issues. This might be circumvented by freeze-drying the reaction mixture before purification. This was done by Skjærpe in one of her attempts.

After the possible pyrolysis of the reaction, it was difficult to dissolve the solids, but some was dissolved in methanol and an effort was made to purify the remains on a flash column. The column was run for more than a week and many hundred fractions were collected. The product only appeared in the late stages, without being completely separated, after several liters of solvent had been used. Due to the time spent, it is likely that the product had diffused throughout the column, causing most compounds to overlap. After draining the column, the later fractions were collected and analyzed, which appears in Figure 32. After evaporating the solvent from the fractions, a new attempt was made to find a mobile phase system that could separate the compounds. The attempts were not successful, as the spots would not migrate on the TLC sheet, even in 50/50 methanol water.

The difficulties when dissolving the dark oil after evaporation, combined with the slow elution from the column may indicate that the product is more polar than thought. It seems as if normal phase (NP) chromatography, where the stationary phase is more polar than the mobile phase, is unsuitable to purify the product, as the polarity of the product causes it to remain stationary on the polar silica sheet/column. It is therefore suggested that separation and purification should be done on a C18 column, using reverse phase (RP) chromatography, where the mobile phase is more polar than the stationary phase.



Figure 31: Column with the suspended yeast settling out and plugging the celite disk.

Results and Discussion

After realizing that the product might be more polar than expected, a few errors made by Skjærpe during her procedure became apparent. Her solvent of choice was consistently dichloromethane, (DCM), which would be far too non-polar when extracting **4**. Attempts to dissolve **4** in different solvents showed that the molecule was insoluble in DCM and during her procedure DCM was used to extract the product, resulting in a concentration that was too low to analyze. This is more than likely due to the triol product being left in the water phase. She assumed that only one of the carbonyl groups were reduced, but again this may be accredited to the triol product of **4** remaining in the water phase and only the trace amount of mono-reduced substrate was non-polar enough to be extracted with DCM. As Skjærpe consistently used DCM for extraction without finding the product, using a more polar solvent, such as methanol or acetonitrile might be better.

Extraction of the samples taken during the reaction was done with DCM, but when the reaction was done the entire bulk liquid was filtered without extraction. As a result the product was luckily not lost in an extraction step.

As purification of this product was also the issue in the source material, it seems that the polarity of the product was underestimated and the experimental procedure should be changed to accommodate that fact. The polarity did not seem to be a problem during the HPLC analyses, which might be due to the packing material in the chiral column is less polar than the silica used in the flash column and during TLC, causing less retention to the column.

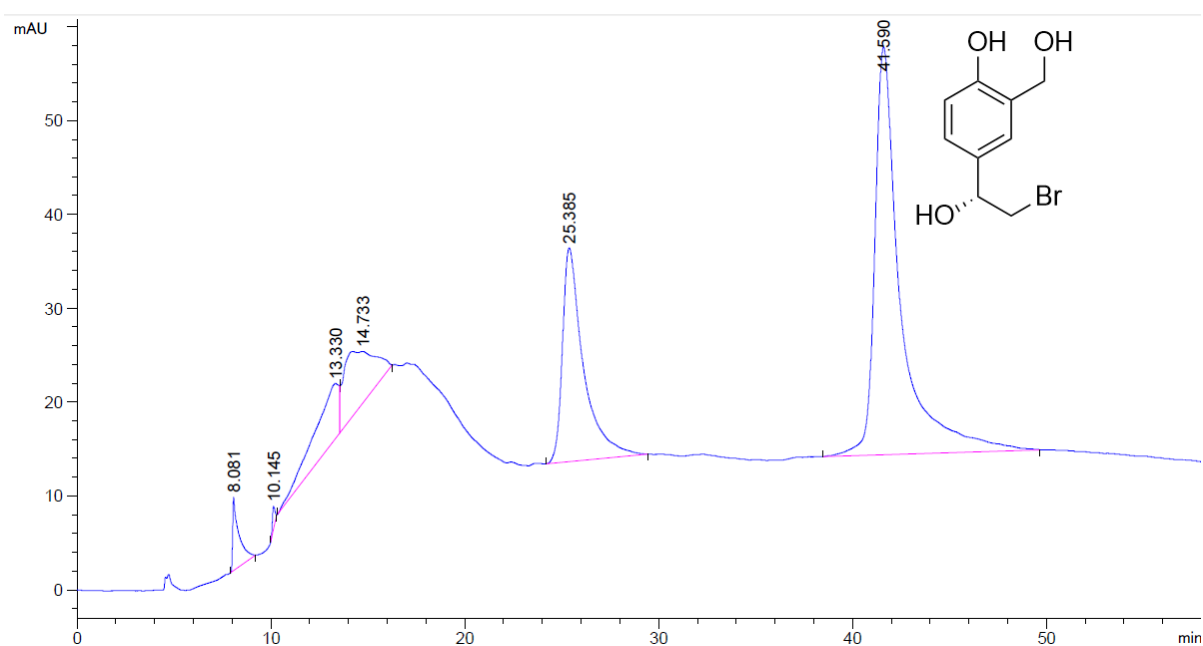

Figure 32: HPLC chromatogram of the collected and concentrated fractions of the yeast reaction

3.1 Synthetic approach

The largest peak in the HPLC chromatogram at $t_R=41$ min indicates that the reaction itself was successful, but further purification has proven difficult and time consuming and could not be completed due to time constraints.

Optical rotation of the product was measured and gave $\alpha=-0.064^\circ$ in dimethyl sulfoxide (DMSO), but $\alpha=+0.003^\circ$ in water. Due to the impurities it was impossible to determine the specific rotation, but the fact that the rotation was negative in DMSO might indicate that there was an enantiomeric excess of the *R*-enantiomer. The low degree of rotation can be explained by the amount of impurities, as a large degree of impurities will result in a low concentration of the enantiomer and therefore a low rotation. As the impurities were most likely achiral and would not affect the rotation, but as the rotation was so low it was impossible to positively determine that only one enantiomer was present.

3.1.6 Bacterial reduction of 5-(2-bromoacetyl)-2-hydroxy-benzaldehyde (**3**) with *L. kefir*

This procedure was intended as a parallel reaction to the reduction with *S. cerevisiae*, but was never attempted due to time constraints.

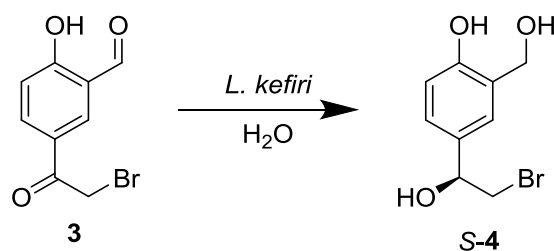

Scheme 13: Reduction of (**3**) to the enantiomeric *S*-alcohol, (*S*)-**4** using *L. kefir*

The stereoselectivity was found in Gröger *et al.* (101) and was very good (>99 %) for similar compounds, and producing a high yield (>94 %). The use of *L. kefir* would, if successful, produce the *S*-enantiomer of salbutamol, which would provide great analytical value despite being the medically inactive distomer. Based on literature, the products from the two different organisms (*L. kefir* and *S. cerevisiae*) would be the two separate enantiomers of salbutamol, which would allow the enantiomers to be easily analyzed separately. This would remove speculation when analyzing HPLC chromatograms for related reactions. Practically speaking, this means that the products from the two organisms would appear as the two separate peaks in Figure 29. As literature shows that the ADH from *L. kefir* is selective towards Anti-Prelog and the ADH from *S. cerevisiae* is selective towards Prelog, it could be presented as evidence

Results and Discussion

of the stereochemistry, proving that *S. cerevisiae* would provide the wanted selectivity in the synthesis of levosalbutamol.

4 Future Work

As far as improvements and further work on the synthesis at hand goes, there are several interesting points to change. Regarding the FC acylation, it would probably be beneficial to attempt the synthesis with NaBH_4 , or to attempt a FC acylation with methanesulfonic anhydride and a α -bromoacetic acid, using the general outline provided by Wilkinson *et al.* (90)

The enantioselective reduction of the ketone should be attempted with the *Rhodococcus erythropolis*, as the ADH from this organism would be *R*-selective in the same manner as *S. cerevisiae*. (101) This organism should have been the one attempted in this thesis, but the wrong organism was ordered by mistake.

The ketone reduction using *S. cerevisiae* should also be attempted again, but with a procedure based on more relevant and specific guidelines, such as the information gathered during this thesis. After the reaction has been stopped, the solution with the yeast biomass should be centrifuged and the supernatant freeze-dried. Purification should be done using RP chromatography, due to the polar nature of the triol product. This would avoid the issues with decomposing glucose, allowing a simple removal of the yeast and an easier purification.

If cooperation with the Institute of Biotechnology was feasible, it would be possible to over-express the ADH and GDH enzymes in *E. coli*, making an efficient designer cell, specifically for ketone reduction similar to that of Gröger. (101) This would require a significant cross institutional effort, but might provide an organism useful in a synthesis on an industrial scale.

In regards to the reduction, using a protecting group to connect the aldehyde and the alcohol might solve the issues had with the workup of the polar triol product. (60) On the other hand, this might not be necessary if more polar solvents are used, and RP chromatography is used for purification.

Lastly, the final step should be attempted in order to complete the synthetic route. This would only require a novel $\text{S}_{\text{N}}2$ reaction, with *t*-butyl amine as the nucleophile and the bromine as a leaving group, producing levosalbutamol as the final product.

These overall steps should culminate in the synthetic route suggested in Scheme 14, providing an overall greener synthetic route to levosalbutamol.

Future Work

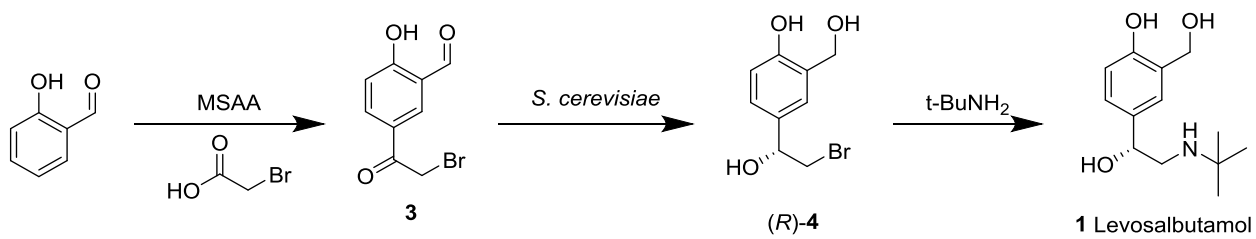

Scheme 14: Suggested synthetic route, from salicylaldehyde to levosalbutamol.

5 Experimental Setup

5.1 General

All tests, experiments and laboratory work were done at the Department of Chemistry, Faculty of Natural Sciences and Technology, Norwegian University of Science and Technology, Trondheim, Norway.

5.1.1 Chemicals and solvents

5.1.1.1 *Chemicals and reagents*

Chemicals and solvents used in the syntheses are commercially available and of analytical grade. The chemicals were purchased from Sigma Aldrich Norway, Oslo, Norway.

Solvents of HPLC-grade were used for HPLC-analyses.

5.1.1.2 *Dry solvents*

Dry solvents (Dichloromethane and tetrahydrofuran) were acquired from a solvent purifier, MBraun MD-SPS800, München, Germany

5.1.1.3 *Enzymes*

Candida antarctica lipase A (CALA) (Viazym; activity 725 U/g, VZ1030-12, batch number 080116) immobilized on microporous beads. Gift from Viazym B, Delft, Netherlands.

5.1.1.4 *Bacteria*

Lactobacillus kefir, DSM 20587 [A/K] was acquired as a freeze-dried culture from ATCC (ATCC[®] 33541[™]) purchased from LGC Standards GmbH, Wesel, Germany.

5.1.1.5 *Yeast*

Saccharomyces cerevisiae was purchased as freeze-dried dry yeast from commercial grocery stores under the name "Idun Tørrgjær", Skjetten, Norway.

5.1.2 Chromatographic analyses

5.1.2.1 *High Performance Liquid Chromatography (HPLC)*

HPLC-analyses were performed on an Agilent-HPLC 1100. Manual injector (Rheodyne 77245i/Agilent 10 µl loop). Two different Chiralcel OD-H columns were used (Purchased 2004 and 2015, Daicel, Chiral Technologies Europe, 250x4.6 mm ID).

Unless stated otherwise, the solvent program used for HPLC was as stated in Table 3 below.

Experimental Setup

Table 3: Gradient program for HPLC, Flow: 0.7 ml/min

<i>Time [min]</i>	<i>Hexane [%]</i>	<i>Isopropanol [%]</i>
0	95	5
5	90	10
60	60	40

5.1.2.2 Thin layer chromatography (TLC)

TLC was done on Merck Silica 60 F₂₅₄ sheets and detected in UV-light, $\lambda=254$ nm.

5.1.2.3 Flash Chromatography

Flash chromatography was done with Silica gel from Sigma Aldrich Norway, Oslo, Norway. Pore size 60 Å, 230 mesh particle size, 40-63 μm particle size.

5.1.3 Spectroscopic methods

5.1.3.1 Nuclear Magnetic Resonance (NMR)

All NMR analyses were done on a 400 MHz Bruker Advance DPX 400 instrument.

5.1.3.2 Mass Spectroscopy (MS)

Accurate mass determination in positive and negative mode was performed on a "Synapt G2-S" Q-TOF instrument from WatersTM. Samples were ionized by the use of ASAP probe (APCI). Calculated exact mass and spectra processing was done by WatersTM Software (Masslynxs V4.1 SCN871).

5.1.4 Other analytical methods, and instruments used

5.1.4.1 Optical rotation

Optical rotation was measured on a PerkinElmer (Model 341) polarimeter, using a 10 cm long 1 ml cell. Samples were dissolved in DMSO or water at room temperature (23 °C). The light measured had a wavelength of $\lambda=589$ nm.

5.1.4.2 Melting point

Melting point studies were done on a Sanyo Gallenkamp MPD350.BM3.5 melting point apparatus, USA

5.1.4.3 Orbital shaker

For the enzymatic and whole organism reactions, a New Brunswick G24 Environmental Incubator Shaker was used. New Brunswick Co. Inc., Edison, New Jersey, USA.

5.2 Synthesis of Compounds

5.2.1 Synthesis of 5-(2-chloroacetyl)-2-hydroxy-benzaldehyde

Dry *aluminum chloride* ($AlCl_3$, 25.0041 g, 0.1875 mol) suspended in *dichloromethane* (40 ml) was added *chloroacetyl chloride* (7.1224 g, 0.0631 mol). The reaction mixture refluxed for 30 minutes before *salicylaldehyde* (6.1177 g, 0.0501 mol) in *dichloromethane* (5 ml) was added dropwise. After 16 hours, the reaction mixture was quenched in *ice* (250 g), *water* (25 ml) and *dichloromethane* (25 ml) and was stirred for 30 minutes. The water phase was extracted with *dichloromethane* (3x30 ml) and the resulting organic phase was washed with *water* (3x30 ml) and *brine* (50 ml). The organic phase was then dried with $MgSO_4$, filtered and evaporated to give light brown crystals. The crude product was recrystallized in *2-butanone*.

Yield: 17.3 %

Purity: 93 %

5.2.2 Synthesis of 5-(2-bromoacetyl)-2-hydroxy-benzaldehyde

Dry *aluminum chloride* ($AlCl_3$, 33.307g, 0.25 mol) suspended in *dichloromethane* (35 ml) was added *bromoacetyl chloride* (9.966 g, 0.63 mol) in *dichloromethane* (7.5 ml). The reaction mixture refluxed for 30 minutes before *salicylaldehyde* (6.132 g, 0.05 mol) in *dichloromethane* (7.5 ml) was added dropwise. After 20 hours, the reaction mixture was quenched in *ice* (300 g), *water* (30 ml) and *dichloromethane* (50 ml) and was stirred for 30 minutes. The water phase was extracted with *dichloromethane* (3x30 ml) and the resulting organic phase was washed with *water* (3x30 ml) and *brine* (50 ml). The organic phase was then dried with $MgSO_4$, filtered and evaporated. The product was recrystallized in *dichloromethane* and *hexane* to give brown crystals.

Yield: 34.9 %

Purity: 94 %

Melting point: 120-122° C

MS(TOF-ASAP): M+H 242.96/244.9 m/z

Experimental Setup

$^1\text{H-NMR}$: 4.4 ppm (s, 2H), 7.1 ppm (d, 8.8 Hz, 1H), 8.2 ppm (dd, 8.8 Hz, 2.3 Hz, 1H), 8.3 ppm (d, 2.3 Hz, 1H), 10.0 ppm (s, 1H), 11.5 ppm (s, 1H)

5.2.3 Synthesis of 4-(2-bromo-1-hydroxyethyl)-2-(hydroxymethyl)phenol with LiAlH_4

LiAlH_4 (0.1518g, 4.0 mmol) was added to dry THF (10 ml). 5-(2-bromoacetyl)-2-hydroxy-benzaldehyde (0.506 g, 1.953 mmol) was dissolved separately in THF (5 ml). The substrate solution was then added dropwise to the LiAlH_4 solution through a condenser while stirring. After 2 hours, the reaction was quenched with 15 ml of a 50/50 mixture of THF and water, and H_2SO_4 (10 ml, 5 %). The product was then extracted with ethyl acetate (3x10 ml) and washed with brine ($\text{NaCl}_{(aq)}$, 2x10 ml) before being dried with MgSO_4 , filtrated and evaporated. For GC-analysis, a sample of the product was derivatized by adding DMSO, pyrimidine and acetic anhydride

Yield: 66 %

Purity: Low

5.2.4 Enzymatic reduction of 5-(2-bromoacetyl)-2-hydroxy-benzaldehyde with *C. antarctica*

A solution of 4-(2-bromo-1-hydroxyethyl)-2-(hydroxymethyl)-phenol (~0.5 mmol) in dichloromethane was added vinyl butyrate (0.411 g) and CAL A (0.003 g) and the reaction mixture was incubated on an orbital shaker at 30°C and 200 rpm for 3 days. No conclusive results achieved due to high impurity.

5.2.5 Yeast reduction of 5-(2-bromoacetyl)-2-hydroxy-benzaldehyde with *S. cerevisiae*

Glucose (7 g) was dissolved in water (50 ml) and autoclaved. The solution was added dry yeast (14 g, *S. cerevisiae*) and *tert*-butanol (2.5 ml). The solution was incubated on an orbital shaker for 30 minutes at 30 °C at 200 rpm. After incubation, the solution was added 5-(2-bromoacetyl)-2-hydroxy-benzaldehyde (1.205 mmol, 0.3122 g) and put in the incubator. After 24, 48, 72, 96, 132 and 168 hours the following procedure was done: A 3 ml sample was taken out and a solution of water (22.5 ml), yeast (7 g) and *tert*-butanol (1.3 ml) was added. The 3 ml sample was added dichloromethane (7 ml), mixed with a whirlmixer and centrifuged. The dichloromethane was then pipetted out and analyzed with HPLC.

5.2 Synthesis of Compounds

After 190 hours, the reaction mixture was taken out and filtration through a celite disk was attempted. The solution was left for filtration for 4-5 days. After 4-5 days, the yeast had settled out and the water phase was pipetted out and filtrated through a new celite disk. The filtrate was then evaporated on a rotating evaporator. The solids formed were attempted dissolved in methanol and purified on a silica flash column. After 7-9 days, the column was emptied and the likely product, as compared with previous HPLC, was found in the late fractions and in the remaining bulk liquid in the column. These fractions were collected and evaporated on a rotor vapor. The remaining product was a yellow-brown oil. HPLC showed large amounts of impurities. A sample of the product (0.074 g) was dissolved in dimethyl sulfoxide (10 ml, DMSO) and analyzed on a polarimeter. A new sample (0.045 g) was dissolved in water (1.5 ml) and analyzed on a polarimeter.

Yield: Not determined (915 % calculated, but too impure to be accurate)

Purity: Low

Optical rotation +0.003° in H₂O, -0.064° in DMSO

Experimental Setup

5.2.6 Bacterial reduction of 5-(2-bromoacetyl)-2-hydroxy-benzaldehyde with *L. kefiri*

A MRS growth medium was prepared according to Table 4 below.

Table 4: Chemicals used to create MRS growth medium. (109)

<i>Compound</i>	<i>g/l</i>
<i>Proteose peptone</i>	10
<i>Beef extract</i>	10
<i>Yeast extract</i>	5
<i>D-glucose</i>	20
<i>Ammonium citrate</i>	2
<i>Manganese sulfate</i>	0.02
<i>Disodium phosphate</i>	2
<i>Sodium acetate</i>	5
<i>Sorbitan monooleate</i>	2

Two 250 ml Erlenmeyer flasks were added *MRS powder* (5.6 g) and *DI water* (105 ml). The flasks were autoclaved. This medium was not used, as focus was shifted towards the yeast reduction due to time constraints.

6 References

1. Skjærpe C. Legemiddel til behandling av astma. Forsøk på syntese av levalbuterol. Trondheim: Norwegian University of Technology and Science; 2003.
2. SciFinder [Internet]. Available from: <https://origin-scifinder.cas.org/>.
3. Solomons TWGF, Craig B. Organic Chemistry. 9th ed. ed. United States of America: John Wiley & Sons; 2008.
4. Nguyen LA, He H, Pham-Huy C. Chiral Drugs: An Overview. *International Journal of Biomedical Science : IJBS*. 2006;2(2):85-100.
5. Leitereg TJ, Guadagni DG, Harris J, Mon TR, Teranishi R. Chemical and sensory data supporting the difference between the odors of the enantiomeric carvones. *Journal of Agricultural and Food Chemistry*. 1971;19(4):785-7.
6. Rouf A, Taneja SC. Synthesis of Single-enantiomer Bioactive Molecules: A Brief Overview. *Chirality*. 2014;26(2):63-78.
7. Gal J. The discovery of biological enantioselectivity: Louis Pasteur and the fermentation of tartaric acid, 1857—A review and analysis 150 yr later. *Chirality*. 2008;20(1):5-19.
8. Carey FAS, Richard J. *Advanced Organic Chemistry. Part A: Structure and Mechanisms*. 5th ed: Springer; 2008.
9. Faber K. *Biotransformations in Organic Chemistry*. 6th ed: Springer; 2011.
10. Ader U, Schneider MP. Enzyme assisted preparation of enantiomerically pure β -adrenergic blockers III. Optically active chlorohydrin derivatives and their conversion. *Tetrahedron: Asymmetry*. 1992;3(4):521-4.
11. Egholm Jacobsen E, Anthonsen T, Farrag El-Behairy M, Sundby E, Nabil Aboul-Enein M, Ibrahim Attia M, et al. Lipase Catalysed Kinetic Resolution of Stiripentol. *International Journal of Chemistry*. 2012;4(1).
12. Koeller KM, Wong C-H. Enzymes for chemical synthesis. *Nature*. 2001;409(6817):232-40.
13. Brown JM, Naik RG. Chelate control in the rhodium-catalysed homogeneous hydrogenation of chiral allylic and homoallylic alcohols. *Journal of the Chemical Society, Chemical Communications*. 1982(6):348-50.
14. Knowles WS. Asymmetric hydrogenation. *Accounts of Chemical Research*. 1983;16(3):106-12.
15. Miyashita A, Yasuda A, Takaya H, Toriumi K, Ito T, Souchi T, et al. Synthesis of 2,2'-bis(diphenylphosphino)-1,1'-binaphthyl (BINAP), an atropisomeric chiral bis(triaryl)phosphine, and its use in the rhodium(I)-catalyzed asymmetric hydrogenation of α -(acylamino)acrylic acids. *Journal of the American Chemical Society*. 1980;102(27):7932-4.
16. Katsuki T, Sharpless KB. The first practical method for asymmetric epoxidation. *Journal of the American Chemical Society*. 1980;102(18):5974-6.
17. Nobelprize.org. The Nobel Prize in Chemistry 2001 - Advanced Information: Nobel Media AB 2014; 2015 [cited 2015 16.07.2015]. Available from: http://www.nobelprize.org/nobel_prizes/chemistry/laureates/2001/advanced.html.

References

18. Finn MG, Sharpless KB. Mechanism of asymmetric epoxidation. 2. Catalyst structure. *Journal of the American Chemical Society*. 1991;113(1):113-26.
19. Lin H, Chen Y-Z, Xu X-Y, Xia S-W, Wang L-X. Preparation of key intermediates of adrenergic receptor agonists: Highly enantioselective production of (*R*)- α -halohydrins with *Saccharomyces cerevisiae* CGMCC 2.396. *Journal of Molecular Catalysis B: Enzymatic*. 2009;57(1-4):1-5.
20. Sharma A, Gamre S, Chattopadhyay S. An asymmetric synthesis of (2*S*,3*S*)-safingol. *Tetrahedron Letters*. 2007;48(4):633-4.
21. Sheldon RA. Chirotechnology: Designing economic chiral syntheses. *Journal of Chemical Technology & Biotechnology*. 1996;67(1):1-14.
22. Thomas G. *Medicinal Chemistry: An Introduction*. 2nd ed. ed. West Sussex, England: John Wiley & Sons; 2007.
23. Agranat I, Wainshtein SR, Zusman EZ. The predicated demise of racemic new molecular entities is an exaggeration. *Nat Rev Drug Discov*. 2012;11(12):972-3.
24. Murakami H. From Racemates to Single Enantiomers – Chiral Synthetic Drugs over the last 20 Years. In: Sakai K, Hirayama N, Tamura R, editors. *Novel Optical Resolution Technologies*. Topics in Current Chemistry. 269: Springer Berlin Heidelberg; 2007. p. 273-99.
25. Gellad WF, Choi P, Mizah M, Good CB, Kesselheim AS. Assessing the chiral switch: approval and use of single-enantiomer drugs, 2001 to 2011. *Am J Manag Care*. 2014;20(3):e90-7.
26. (NAAF) TNAaAA. Useful facts on asthma (astma) 2007 [updated 03.07.2007; cited 2015 25.05.2015]. Available from: <http://www.naaf.no/astma/Useful-facts-on-asthma/>.
27. Granum BK, Øystein; Nafstad, Per Namork, Ellen; Nystad, Wenche. *Folkehelse rapporten 2014: Folkehelseinstituttet; 2014* [updated 09.04.2015; cited 2015 25.05.2015]. Available from: <http://www.fhi.no/artikler/?id=110549>.
28. WHO. Asthma - Fact sheet: <http://www.who.int>; 2013 [cited 2015 09.04.2015]. Available from: <http://www.who.int/mediacentre/factsheets/fs307/en/>.
29. Hsu CH, Lu CM, Chang TT. Efficacy and safety of modified Mai-Men-Dong-Tang for treatment of allergic asthma. *Pediatric Allergy and Immunology*. 2005;16(1):76-81.
30. Crosta P. All About Asthma: *Medical News Today*; 2007 [updated 05.03.2013; cited 2015 25.05.2015]. Available from: <http://www.medicalnewstoday.com/info/asthma/>.
31. World Population Prospects, the 2012 Revision [press release]. <http://www.un.org>, 17.06.2013 2013.
32. Al-Hajjaj MS. Bronchial asthma in developing countries: A major social and economic burden. *Annals of Thoracic Medicine*. 2008;3(2):39-40.
33. Norwegian Prescription Database [Internet]. 2014 [cited 25.05.2015]. Available from: <http://www.norpd.no/default.aspx>.
34. Accordini S, Corsico AG, Braggion M, Gerbase MW, Gislason D, Gulsvik A, et al. The Cost of Persistent Asthma in Europe: An International Population-Based Study in Adults. *International Archives of Allergy and Immunology*. 2013;160(1):93-101.
35. Barnett SBL, Nurmagambetov TA. Costs of asthma in the United States: 2002-2007. *Journal of Allergy and Clinical Immunology*. 2011;127(1):145-52.

36. Reece JBU, Lisa A.;Cain, Michael L.; Wasserman, Steven A.; Minorsky, Peter V.; Jackson, Robert B. Campbell Biology. 9th ed. Boston: Pearson; 2011.
37. AAFA. Non-Allergic Asthma www.aafa.org: Asthma and Allergy Foundation of America; [cited 2015 17.07]. Available from: <https://www.aafa.org/display.cfm?id=8&sub=17>.
38. Tveit EV. "Blod", a report for the course: Cellular and Molecular Biology. NTNU, 2013.
39. Tizard I. Veterinary Immunology. An Introduction. 6th ed: Saunders; 2001.
40. Nelson DL, Nelson DL, Lehninger AL, Cox MM. Lehninger Principles of biochemistry. New York: W.H. Freeman; 2008.
41. Maddox L, Schwartz DA. The Pathophysiology of Asthma. Annual Review of Medicine. 2002;53(1):477-98.
42. Akdis CA, Blaser K. Histamine in the immune regulation of allergic inflammation. Journal of Allergy and Clinical Immunology. 2003;112(1):15-22.
43. Barnes PJ. Histamine and Serotonin. Pulmonary Pharmacology & Therapeutics. 2001;14(5):329-39.
44. Strader CD, Fong TM, Tota MR, Underwood D, Dixon RAF. Structure and Function of G Protein-Coupled Receptors. Annual Review of Biochemistry. 1994;63(1):101-32.
45. Swaminath G, Deupi X, Lee TW, Zhu W, Thian FS, Kobilka TS, et al. Probing the β 2 Adrenoceptor Binding Site with Catechol Reveals Differences in Binding and Activation by Agonists and Partial Agonists. Journal of Biological Chemistry. 2005;280(23):22165-71.
46. Van Ganse E, Kaufman L, Derde M, Yernault J, Delaunois L, Vincken W. Effects of antihistamines in adult asthma: a meta-analysis of clinical trials. European Respiratory Journal. 1997;10(10):2216-24.
47. Cazzola M, Page CP, Calzetta L, Matera MG. Pharmacology and Therapeutics of Bronchodilators. Pharmacological Reviews. 2012;64(3):450-504.
48. Jones TR, Charette L, Garcia ML, Kaczorowski GJ. Selective inhibition of relaxation of guinea-pig trachea by charybdotoxin, a potent Ca^{++} -activated K^{+} channel inhibitor. Journal of Pharmacology and Experimental Therapeutics. 1990;255(2):697-706.
49. (NAAF) TNAAaAA. Astmakontroll - NAAFs informasjonsbrosjyre 2006 [updated 06.13.2015; cited 2015 20.07]. Available from: <http://www.naaf.no/en/astma/astmakontroll/>.
50. New once-daily Striverdi* (olodaterol) Respimat® gains approval in first EU countries [press release]. Online: Boehringer Ingelheim, 18.10.2013 2013.
51. Cazzola M, Calzetta L, Matera MG. β ₂-adrenoceptor agonists: current and future direction. British Journal of Pharmacology. 2011;163(1):4-17.
52. Barnes PJ, Adcock IM. How Do Corticosteroids Work in Asthma? Annals of Internal Medicine. 2003;139(5_Part_1):359-70.
53. Lambrecht BN, Hammad H. The immunology of asthma. Nat Immunol. 2015;16(1):45-56.
54. Peters-Golden M, Canetti C, Mancuso P, Coffey MJ. Leukotrienes: Underappreciated Mediators of Innate Immune Responses. The Journal of Immunology. 2005;174(2):589-94.
55. Asthma and COPD Therapies: World Market 2013-2023 [press release]. 2013.

References

56. Millership JS, Fitzpatrick A. Commonly used chiral drugs: A survey. *Chirality*. 1993;5(8):573-6.
57. Fozard JR, Buescher H. Comparison of the Anti-bronchoconstrictor Activities of Inhaled Formoterol, its (*R,R*)- and (*S,S*)-Enantiomers and Salmeterol in the Rhesus Monkey. *Pulmonary Pharmacology & Therapeutics*. 2001;14(4):289-95.
58. Hett R, Stare R, Helquist P. Enantioselective synthesis of salmeterol via asymmetric borane reduction. *Tetrahedron Letters*. 1994;35(50):9375-8.
59. Jat KR, Khairwa A. Levalbuterol versus albuterol for acute asthma: A systematic review and meta-analysis. *Pulmonary Pharmacology & Therapeutics*. 2013;26(2):239-48.
60. Liu J, Zhou D, Jia X, Huang L, Li X, Chan ASC. A convenient synthesis of (*R*)-salmeterol via Rh-catalyzed asymmetric transfer hydrogenation. *Tetrahedron: Asymmetry*. 2008;19(15):1824-8.
61. Stoschitzky KL, W; Zernig, G. Racemic beta-blockers - fixed combinations of different drugs. *Journal of Clinical and Basic Cardiology*. 1998;1(1):15-9.
62. Kelly HW. Levalbuterol for asthma: A better treatment? *Curr Allergy Asthma Rep*. 2007;7(4):310-4.
63. Hilaire ML, Wozniak JR. Levalbuterol Tartrate (Xopenex HFA) for the Treatment of Bronchospasm. *Am Fam Physician*. 2007;75(2):247-8.
64. Berger WE. Levalbuterol: pharmacologic properties and use in the treatment of pediatric and adult asthma. *Ann Allergy Asthma Immunol*. 2003;90(6):583-91; quiz 91-2, 659.
65. Ameredes B, Calhoun W. Levalbuterol versus albuterol. *Curr Allergy Asthma Rep*. 2009;9(5):401-9.
66. Schreck DM, Babin S. Comparison of racemic albuterol and levalbuterol in the treatment of acute asthma in the ED. *The American Journal of Emergency Medicine*. 2005;23(7):842-7.
67. Nowak R. Single-isomer levalbuterol: A review of the acute data. *Curr Allergy Asthma Rep*. 2003;3(2):172-8.
68. Sheldon RA. The E Factor [Webpage]. [cited 2015 09.07.2015]. Available from: <http://www.sheldon.nl/bi/EFactor.aspx>.
69. Sheldon RA. Catalysis: The Key to Waste Minimization. *Journal of Chemical Technology & Biotechnology*. 1997;68(4):381-8.
70. EPA U. Green Chemistry: United States Environmental Protection Agency; [cited 2015 09.07.2015]. Available from: <http://www2.epa.gov/green-chemistry>.
71. UNWCED. Our Common Future. 1987.
72. Anastas PTW, J. C. Green Chemistry: Theory and Practice. New York: Oxford University Press; 1998.
73. Dunn PJ, Galvin S, Hettenbach K. The development of an environmentally benign synthesis of sildenafil citrate (Viagra[trade mark sign]) and its assessment by Green Chemistry metrics. *Green Chemistry*. 2004;6(1):43-8.
74. Hartman LFO, A. L. On Beer and Brewing Techniques in Ancient Mesopotamia. *Journal of the American Oriental Society*. 1950(10).

75. Romano D, Contente M, Molinari F, Eberini I, Ruvutuso E, Sensi C, et al. Recombinant *S. cerevisiae* expressing Old Yellow Enzymes from non-conventional yeasts: an easy system for selective reduction of activated alkenes. *Microbial Cell Factories*. 2014;13(1):60.
76. Fardelone L, Augusto J, Rodrigues R, Moran P. Baker's yeast mediated asymmetric reduction of cinnamaldehyde derivatives. *J Mol Catal B: Enzym*. 2004;29:41 - 5.
77. Weber N, Gorwa-Grauslund M, Carlquist M. Engineered baker's yeast as whole-cell biocatalyst for one-pot stereo-selective conversion of amines to alcohols. *Microbial Cell Factories*. 2014;13(1):118.
78. Levene PA, Walti A. 1-Propylene Glycol. *Organic Syntheses: John Wiley & Sons, Inc.*; 2003.
79. Grogan G. *Practical Biotransformations. A Beginner's Guide*. United Kingdom: Wiley & Sons; 2009.
80. Aehle W. *Enzymes in Industry: Wiley-VCH Verlag GmbH & Co. KGaA*; 2007.
81. Aboul-Enein HYA-B, Abdullah A.;Ibrahim, S. E. . Salbutamol. In: Florey K, editor. *Analytical Profiles of Drug Substances*. 10. New York: Academic Press; 1981. p. 665.
82. Babad E, Carruthers NI, Jaret RS, Steinman M. A Short Synthesis of Albuterol. *Synthesis*. 1988;1988(12):966-8.
83. Gao Y, Zepp CM, inventors; Sepacor, assignee. Enantioselective preparation of optically pure albuterol1996.
84. Gao Y, Zepp CM, inventors; Sepacor, assignee. Enantioselective preparation of optically pure albuterol1995.
85. Huang L, Liu J, Shan W, Liu B, Shi A, Li X. The asymmetric synthesis of (*R,R*)-formoterol via transfer hydrogenation with polyethylene glycol bound Rh catalyst in PEG2000 and water. *Chirality*. 2010;22(2):206-11.
86. Zhang ZR, inventor; Google Patents, assignee. Production technology for synthesizing salbutamol sulphate. China patent CN104356009 A. 2015.
87. Carey FAS, Richard J. *Advanced Organic Chemistry. Part B: Reactions and Synthesis*. 5th edition ed. United States of America: Springer; 2007.
88. Hoff BH, Sundby E. Preparation of pharmaceutical important fluorinated 1-arylethanol using isolated enzymes. *Bioorganic Chemistry*. 2013;51(0):31-47.
89. Rueping M, Nachtsheim BJ. A review of new developments in the Friedel–Crafts alkylation – From green chemistry to asymmetric catalysis. *Beilstein Journal of Organic Chemistry*. 2010;6:6.
90. Wilkinson MC. “Greener” Friedel–Crafts Acylations: A Metal- and Halogen-Free Methodology. *Organic Letters*. 2011;13(9):2232-5.
91. Xu G-C, Yu H-L, Zhang X-Y, Xu J-H. Access to Optically Active Aryl Halohydrins Using a Substrate-Tolerant Carbonyl Reductase Discovered from *Kluyveromyces thermotolerans*. *ACS Catalysis*. 2012;2(12):2566-71.
92. Zhang R, Zhang B, Xu Y, Li Y, Li M, Liang H, et al. Efficient (*R*)-Phenylethanol Production with Enantioselectivity-Alerted (*S*)-Carbonyl Reductase II and NADPH Regeneration. *PLoS One*. 2013;8(12).

References

93. Xu G, Yu H, Xu J. Facile Access to Chiral Alcohols with Pharmaceutical Relevance Using a Ketoreductase Newly Mined from *Pichia guilliermondii*. *Chinese Journal of Chemistry*. 2013;31(3):349-54.
94. Xie Y, Xu J-H, Xu Y. Isolation of a *Bacillus* strain producing ketone reductase with high substrate tolerance. *Bioresource Technology*. 2010;101(3):1054-9.
95. Nie Y, Xiao R, Xu Y, Montelione GT. Novel anti-Prelog stereospecific carbonyl reductases from *Candida parapsilosis* for asymmetric reduction of prochiral ketones. *Organic & Biomolecular Chemistry*. 2011;9(11):4070-8.
96. He S, Wang Z, Zou Y, Chen S, Xu X. Purification and characterization of a novel carbonyl reductase involved in oxidoreduction of aromatic β -amino ketones/alcohols. *Process Biochemistry*. 2014;49(7):1107-12.
97. Naimi-Jamal MR, Mokhtari J, Dekamin MG, Kaupp G. Sodium Tetraalkoxyborates: Intermediates for the Quantitative Reduction of Aldehydes and Ketones to Alcohols through Ball Milling with NaBH_4 . *European Journal of Organic Chemistry*. 2009;2009(21):3567-72.
98. Li X, Liu J, Zhou D, Huang L, inventors; University of Sun Yat Sen, assignee. Unsymmetrical hydrogen transfer synthetic method of (*R*)-salmeterol. China2010.
99. Hölsch K, Havel J, Haslbeck M, Weuster-Botz D. Identification, Cloning, and Characterization of a Novel Ketoreductase from the Cyanobacterium *Synechococcus* sp. Strain PCC 7942. *Applied and Environmental Microbiology*. 2008;74(21):6697-702.
100. Pollard D, Truppo M, Moore J, Kosjek B, Tellers D, Moore J, et al. Synthesis of Chiral sec-Alcohols by Ketone Reduction. *Practical Methods for Biocatalysis and Biotransformations*: John Wiley & Sons, Ltd; 2009. p. 273-94.
101. Gröger H, Chamouleau F, Orogas N, Rollmann C, Drauz K, Hummel W, et al. Enantioselective Reduction of Ketones with “Designer Cells” at High Substrate Concentrations: Highly Efficient Access to Functionalized Optically Active Alcohols. *Angewandte Chemie International Edition*. 2006;45(34):5677-81.
102. Poole CF. *The Essence of Chromatography*. 1st ed. United States of America: Elsevier; 2003.
103. Henriksen S. Prosjektoppgave: Syntese av byggestein for astmamiddelet Levalbuterol. [Course project for TKJ4130]. In press 2014.
104. Beavon RJ, Alan. *Periodicity, Quantitative Equilibrium and Functional Group Chemistry*. United Kingdom: Nelson Thornes; 2003.
105. Oestreich M. Arenecarbaldehydes: synthesis by C-C bond formation. *Sci Synth*. 2007;25:667-88.
106. Brown AD, Lane CAL, Glossop PA, Price DA, Lewthwaite RA, Bunnage ME, et al., inventors; Pfizer Inc, assignee. Compounds useful for the treatment of diseases. United States of America2009.
107. Vinu R, Broadbelt LJ. A mechanistic model of fast pyrolysis of glucose-based carbohydrates to predict bio-oil composition. *Energy & Environmental Science*. 2012;5(12):9808-26.
108. Everts S. The Maillard Reaction Turns 100. *Chemical & Engineering News*. 2012.
109. Standards L. ATCC® Medium 416: Lactobacilli MRS Agar/Broth.