



Norwegian University of  
Science and Technology

# Improved combustion in wood stoves

Reduksjon av utslipp i vedovner

**Mario Ortega**

Master of Science in Product Design and Manufacturing

Submission date: August 2008

Supervisor: Johan Einar Hustad, EPT

Norwegian University of Science and Technology  
Department of Energy and Process Engineering



# Problem Description

Background and objective.

Norway uses approximately half of the bioenergy consumption in wood stoves and fireplaces. An amount of approximately 7 TWh is consumed in such units. Old stoves have been a source to large particle emissions, and in 1998 new regulations came into force which limits these emissions. However, to reduce these emissions further, new and improved combustion principles have to be developed. SINTEF in co-operation with the Norwegian industry are running a project financed partly by the Research Council emphasizing new technology developments in this field. The Master thesis will take part in these studies developing new and improved technology for emission reductions.

The following questions should be considered in the project work:

1. Literature studies on different technologies and methods for measurements and emission reduction in wood stoves and fireplaces.
2. Suggest experimental tests for studying measurements in stack and dilution tunnel. The experimental test setup shall be explained and give the reason for.
3. Do testing in accordance with the suggested experimental test setup.
4. Discuss the results and give an explanation of the obtained results
5. Discuss and give suggestions of the best way for measuring and testing emissions from wood stoves and fireplaces.

Assignment given: 01. February 2008

Supervisor: Johan Einar Hustad, EPT



# Preface

This Master's Thesis report is the result of Mario Ortega's work in the Department of Energy and Process Engineering of the Norwegian University of Science and Technology (NTNU). The project was developed within the Sócrates-Erasmus program during the spring of 2008.

This project has greatly increased my interest and motivation within the field of biomass combustion and has improved my knowledge about emission reduction in small-scale wood burning appliances.

I would like to thank my supervisors Prof. J.E. Hustad and M.Sc. Edvard K. Karlsvik for their continuous guidance and help. Also, I would like to thank the NTNU and my home university, the ETSI of Bilbao, for giving me the great opportunity of studying this year in Norway in the fantastic city of Trondheim.

Special thanks go to my family and friends.

Mario Ortega Cela

Spring 2008



# Abstract

There are two main ways of measuring particle emission from wood combustion. Firstly, particles can be sampled directly in the chimney. Secondly, a dilution tunnel can be used, thus cooling the flue gases parallel to diluting. The purpose of this work is to investigate the differences between both measurements and establish which is the best method to measure particle emission from wood combustion. The approach is to perform particle emission measurements in the chimney and in a dilution tunnel simultaneously during the combustion of wood in a small-scale appliance. Moreover, Flame Ionization Analysis will be carried out to understand the contribution of condensed organic compounds to the total particulate matter emission.

The particle emission measured in the dilution tunnel was between 5 and 12 times higher than in the chimney. The more unfavourable combustion conditions, the larger the difference between both measurements was seen. The results also show a factor of about 2,5 between both particle emission measured in the stack and Total Hydrocarbon content in the flue gas and particle emission measured in the dilution tunnel, indicating that about 35 % of the hydrocarbons measured in the stack with the Flame Ionization Detector condense along the dilution tunnel accounting for approximately 85 % of the total particle emission found at this location.





# Contents

<b>List of Figures</b>	<b>12</b>
<b>List of Tables</b>	<b>14</b>
<b>1 Introduction</b>	<b>15</b>
<b>2 Wood Combustion</b>	<b>17</b>
2.1 Wood composition . . . . .	17
2.2 The combustion process . . . . .	18
2.3 Firing habits in Norway . . . . .	19
<b>3 Emissions from Wood Combustion</b>	<b>21</b>
3.1 Emissions from complete combustion . . . . .	22
3.1.1 Carbon dioxide (CO <sub>2</sub> ) . . . . .	22
3.1.2 Particle emissions from complete combustion (ashes) . . . . .	22
3.2 Emissions from incomplete combustion . . . . .	22
3.2.1 Carbon Monoxide (CO) . . . . .	23
3.2.2 Volatile Organic Compounds (VOC) and Polycyclic Aromatic Hydrocarbons (PAH) . . . . .	24
3.2.3 Particle emissions from incomplete combustion . . . . .	26

---

3.3	Influence of particle sampling . . . . .	27
3.4	Particulate Matter . . . . .	28
3.5	Particulate matter effects on Human health . . . . .	29
3.6	Measures for particle emission reduction . . . . .	30
<b>4</b>	<b>The Standards</b>	<b>31</b>
4.1	EN-13240 . . . . .	32
4.1.1	Description of performance test at nominal heat output . . . . .	33
4.1.2	Requirements for performance test at nominal heat output . . . . .	33
4.2	German - Austrian particle test method . . . . .	34
4.3	United Kingdom particle test method . . . . .	36
4.4	CEN tasks for a common particle emission test method . . . . .	37
4.5	U.S.A particle test method . . . . .	38
<b>5</b>	<b>The Stove: Jøtul F3</b>	<b>41</b>
5.1	Main features of the stove . . . . .	41
5.2	Activation zone . . . . .	43
5.3	Stove's air vents . . . . .	43
5.4	Wood consumption and nominal heat output . . . . .	44
<b>6</b>	<b>The Test Facility and the Measurements</b>	<b>47</b>
6.1	The test facility . . . . .	47
6.2	The measurements . . . . .	48
6.2.1	CO, CO <sub>2</sub> and O <sub>2</sub> measurements in the stack . . . . .	50
6.2.2	CO and CO <sub>2</sub> measurements in the dilution tunnel . . . . .	51

---

6.2.3	Particle measurements in the stack and dilution tunnel . . . . .	52
6.2.4	Hydrocarbons measurement in the stack . . . . .	53
6.3	The Norwegian Standard . . . . .	54
6.3.1	The fuel . . . . .	54
6.3.2	The different burn rate categories . . . . .	55
6.4	Running a test according to the Norwegian Standard . . . . .	56
6.5	Running a test according to the EN-13240 Standard . . . . .	57
<b>7</b>	<b>Results and Discussion</b>	<b>59</b>
7.1	Fuelsim - Transient . . . . .	59
7.2	Emission factors . . . . .	60
7.3	Problems during testing . . . . .	60
7.4	Appropriate use of the Flame Ionization Analyzer . . . . .	61
7.5	Combustion conditions . . . . .	61
7.6	Particle emission . . . . .	62
7.7	Efficiencies . . . . .	64
7.8	Comparison between stack and dilution tunnel . . . . .	66
7.9	Accuracy and Reliability . . . . .	73
<b>8</b>	<b>Conclusions</b>	<b>75</b>
	<b>Bibliography</b>	<b>77</b>

---

<b>A</b>	<b>Calculations</b>	<b>81</b>
A.1	Gas meter volume . . . . .	81
A.2	Particulate concentration . . . . .	82
A.3	Particulate emission rate . . . . .	82
A.4	Adjusted particulate emission rate . . . . .	82
A.5	Particulate Emission Requirements . . . . .	83
A.6	Calculation of weighted particulate emission . . . . .	83
<b>B</b>	<b>Norwegian Standard Graphs</b>	<b>85</b>
<b>C</b>	<b>EN-13240 Graphs</b>	<b>117</b>

# List of Figures

2.1	Two-staged air combustion . . . . .	19
3.1	CO emission as a function of the excess air ratio $\lambda$ . . . . .	24
3.2	Influence of combustion temperature in PAH emission . . . . .	25
3.3	Hydrocarbons from wood burning (%weight) . . . . .	26
4.1	Flue draught values . . . . .	34
4.2	Sampling train according to VDI 2066 . . . . .	35
4.3	Filter system according to VDI 2066 . . . . .	35
4.4	Test facility used in The United Kingdom . . . . .	36
4.5	CEN proposed test facility . . . . .	37
4.6	CEN proposed sampling train . . . . .	38
4.7	Test Facility used in EPA method 5G (USA) . . . . .	39
5.1	Air flow pattern inside the stove . . . . .	42
5.2	Secondary air system . . . . .	42
5.3	Front view of Jøtul F3 with both air vents . . . . .	44
6.1	Test facility according to the Norwegian standard . . . . .	48
6.2	Measurements in the stack . . . . .	48

---

6.3	Measurements in the dilution tunnel . . . . .	49
6.4	Stack flue gas measuring unit . . . . .	51
6.5	Sampling unit for particle measurements . . . . .	52
6.6	Filter holder . . . . .	53
6.7	Size of the standard test fuel . . . . .	54
6.8	Damper used during EN-13240 tests . . . . .	57
7.1	Norwegian Standard - Particle emission related to burning rate . . . . .	63
7.2	EN Standard - Particle emission related to burning rate . . . . .	64
7.3	Norwegian Standard - $PM_s$ , Total Hydrocarbon content in the flue gas and $PM_d$	67
7.4	Norwegian Standard - Comparison of PM emission in stack and dilution tunnel	67
7.5	Norwegian Standard - Ratio between PM in the dilution tunnel and PM in the stack . . . . .	68
7.6	Norwegian Standard - Ratio between THC + PM in the stack and PM in the dilution tunnel . . . . .	68
7.7	Norwegian Standard - Percentage of hydrocarbons measured with the FID found as particles in the dilution tunnel . . . . .	69
7.8	Norwegian Standard - Percentage of total PM measured in the dilution tunnel consisting of condensed organic matter . . . . .	69
7.9	Norwegian Standard - Ratio $PM_d/PM_s$ related to combustion conditions . .	70
7.10	EN Standard - Comparison of PM emission in stack and dilution tunnel . . .	71
7.11	EN Standard - Ratio between PM in the dilution tunnel and PM in the stack	72
7.12	Typical look of the filters after performing the tests . . . . .	73
B.1	Test 16 - Graphs (a)-(c) . . . . .	87
B.2	Test 16 - Graphs (d)-(f) . . . . .	88

---

B.3	Test 16 - Graphs (g)-(h)	89
B.4	Test 17 - Graphs (a)-(c)	90
B.5	Test 17 - Graphs (d)-(f)	91
B.6	Test 17 - Graphs (g)-(h)	92
B.7	Test 18 - Graphs (a)-(c)	93
B.8	Test 18 - Graphs (d)-(f)	94
B.9	Test 18 - Graphs (g)-(h)	95
B.10	Test 19 - Graphs (a)-(c)	96
B.11	Test 19 - Graphs (d)-(f)	97
B.12	Test 19 - Graphs (g)-(h)	98
B.13	Test 20 - Graphs (a)-(c)	99
B.14	Test 20 - Graphs (d)-(f)	100
B.15	Test 20 - Graphs (g)-(h)	101
B.16	Test 21 - Graphs (a)-(c)	102
B.17	Test 21 - Graphs (d)-(f)	103
B.18	Test 21 - Graphs (g)-(h)	104
B.19	Test 22 - Graphs (a)-(c)	105
B.20	Test 22 - Graphs (d)-(f)	106
B.21	Test 22 - Graphs (g)-(h)	107
B.22	Test 23 - Graphs (a)-(c)	108
B.23	Test 23 - Graphs (d)-(f)	109
B.24	Test 23 - Graphs (g)-(h)	110
B.25	Test 30 - Graphs (a)-(c)	111

---

B.26 Test 30 - Graphs (d)-(f) . . . . .	112
B.27 Test 30 - Graphs (g)-(h) . . . . .	113
B.28 Test 31 - Graphs (a)-(c) . . . . .	114
B.29 Test 31 - Graphs (d)-(f) . . . . .	115
B.30 Test 31 - Graphs (g)-(h) . . . . .	116
C.1 Test 35 - Graphs (a)-(c) . . . . .	119
C.2 Test 35 - Graphs (d)-(f) . . . . .	120
C.3 Test 36 - Graphs (a)-(c) . . . . .	121
C.4 Test 36 - Graphs (d)-(f) . . . . .	122
C.5 Test 37 - Graphs (a)-(c) . . . . .	123
C.6 Test 37 - Graphs (d)-(f) . . . . .	124
C.7 Test 38 - Graphs (a)-(c) . . . . .	125
C.8 Test 38 - Graphs (d)-(f) . . . . .	126
C.9 Test 39 - Graphs (a)-(c) . . . . .	127
C.10 Test 39 - Graphs (d)-(f) . . . . .	128
C.11 Test 40 - Graphs (a)-(c) . . . . .	129
C.12 Test 40 - Graphs (d)-(f) . . . . .	130



# List of Tables

2.1	Main constituents of the wood . . . . .	17
3.1	Immision limit values for PM <sub>10</sub> . . . . .	29
4.1	Carbon monoxide emission requirements . . . . .	33
4.2	Efficiency requirements at nominal heat output . . . . .	34
4.3	Average wood consumption rates for method 5G (USA) . . . . .	39
5.1	Technical data according to EN-13240 . . . . .	44
5.2	Recommended fuel size . . . . .	45
6.1	Measuring equipment . . . . .	49
6.2	Location of thermocouples . . . . .	50
6.3	Gas analyzers used in the stack . . . . .	51
6.4	Gas analyzers used in the dilution tunnel . . . . .	52
6.5	Flame Ionization Detector (FID) . . . . .	53
6.6	Moisture content of the test fuel . . . . .	55
6.7	Burn rate categories according to the Norwegian Standard . . . . .	55
7.1	Norwegian Standard - Combustion conditions . . . . .	62

---

7.2	EN Standard - Combustion conditions . . . . .	62
7.3	Norwegian Standard - Adjusted particle emission . . . . .	63
7.4	Norwegian Standard - Efficiencies . . . . .	65
7.5	EN Standard - Data according to EN-13240 . . . . .	65
7.6	Norwegian Standard - Comparison between stack and dilution tunnel . . . . .	66
7.7	EN Standard - Comparison between stack and dilution tunnel . . . . .	71
A.1	Particulate emission requirements in Norway . . . . .	83

# Chapter 1

## Introduction

Wood is a renewable energy source considered to be CO<sub>2</sub>-neutral with respect to the global carbon cycle, i.e. provided that we do not fell more timber than what it grows, the combustion of wood does not contribute globally to the greenhouse effect. Annually, the growth in Norwegian forests exceeds the felling of trees. Therefore, in Norway, the forests will actually benefit from human activities.

These are powerful reasons to increase the use of wood as an environmentally sustainable fuel for heat and power generation, especially with the current prices of oil and natural gas. Nevertheless, a further propagation of wood combustion may be hindered by the disadvantage of its high particle emissions.

Since restrictions on particulate matter in the atmosphere are getting stricter due to its adverse effects on human health, it will be necessary to reduce sources of particulate matter to the air. Biomass combustion is a relevant source of fine particles, especially in small-scale applications like wood stoves. To assist the development of environmentally friendly wood stoves it would be desirable to have a common standard for particle emission testing and appliance certification. However, there are many kinds of methods used for this purpose and there is no common standardized method within Europe.

One of the main differences between the various methods available is the location of the measurement. There are two main ways of measuring particle emission from wood combustion. Firstly, particles can be sampled directly in the hot flue gases (in the chimney). Secondly, a dilution tunnel can be used, thus cooling the flue gases parallel to diluting, simulating what happens as the flue gas from the chimney goes out to the ambient air.

The aim of this project is the comparison between particle sampling in the stack and in a dilution tunnel during wood combustion, to quantify the difference between both measurements and investigate which location is more representative of what truly happens when the flue gases reach the atmosphere.

The approach is to perform particle emission measurements in the chimney and in a dilution tunnel simultaneously during the combustion of wood in a small-scale appliance. Moreover, Flame Ionization Analysis will be carried out to understand the contribution of condensed organic compounds to the total particulate matter emission.

Firstly, the main characteristics of wood combustion will be explained briefly. Secondly, the emissions from wood combustion will be described, followed by the presentation of the main methods currently available for measuring particle emission from wood combustion. The stove used during the tests will be presented next. In chapter 6, the test facility used and the different measurements are described. Finally, the results are presented and discussed. The main findings will be summarized in the conclusion.

# Chapter 2

## Wood Combustion

In this project, the combustion of wood as a batch process is of interest. During combustion, the photosynthetic energy stored in the wood is released and converted into heat, infrared radiation, light and other forms of energy.

### 2.1 Wood composition

The main components of wood are cellulose, hemicellulose and lignin. They are all made of carbon, hydrogen and oxygen atoms. Wood is similar in structure to fiberglass. The fibrous part of wood that is similar to glass fibers is called cellulose. The cellulose is embedded in a material called lignin, which acts like the resin in fiberglass. Wood also contains a large amount of water, as well as minerals, oils and other compounds.

The main constituents of the wood that will be used during the tests are presented in Table 2.1. The water content of the wood is not included. Being a very important factor, it will be measured for each test fuel.

Wood	Carbon	Hydrogen	Oxygen	Nitrogen
Spruce	47,25 %	6,3 %	46,38 %	0,07 %
Birch	47,12 %	6,22 %	46,55 %	0,11 %

Table 2.1: Main constituents of the fuel [30]

## 2.2 The combustion process

Every combustion requires three elements: the fuel, an oxidizer and a source of heat. When these three elements are combined in the appropriate environment, combustion will occur. If any of the elements is removed, combustion stops. In wood combustion, wood is obviously the fuel, air is the oxidizer and the initial source of heat is usually the flame from a match or a lighter. When burning wood for heat production it is desired to have a complete combustion. This means that all the hydrogen in the wood is converted to water and all the carbon is transformed to carbon dioxide.

The combustion of wood can be divided in three main processes:

- Pre-heating and evaporation: The wood is heated to evaporate and drive off moisture. Since vaporization robs heat energy from the combustion process, it lowers the temperature in the combustion chamber, which slows down the combustion process [7]. This makes the water content in the wood a very important factor. Wood with a high moisture content is hard to ignite.
- Devolatilization/Gasification: When heated to temperatures over 300 °C wood turns into gaseous components (volatile components like CO, H<sub>2</sub>, CH<sub>4</sub> and others) and solid carbon (char). At 500 °C about 85% by weight of the wood substance is converted into gaseous compounds [14]. This gaseous compounds contain between 50 and 60 percent of the heat value of the wood.
- Combustion: After volatile gases are released, the remaining material is charcoal. When the temperature is high enough, the flaming combustion of the released volatile gases and the char oxidation take place. In batch combustion applications there will be a distinct separation between a volatile and a char combustion phase, in both position and time.

In most modern wood stoves air staged combustion with primary and secondary air inlet is used. The wood is gasified with primary air before the combustible gases and the char are oxidized with secondary air. Through the separation of the devolatilization and the gas and char combustion the mixing of the fuel with air is improved, the combustion temperature is increased and the emission of unburnt pollutants is reduced. The two-staged air combustion is shown in Figure 2.1.

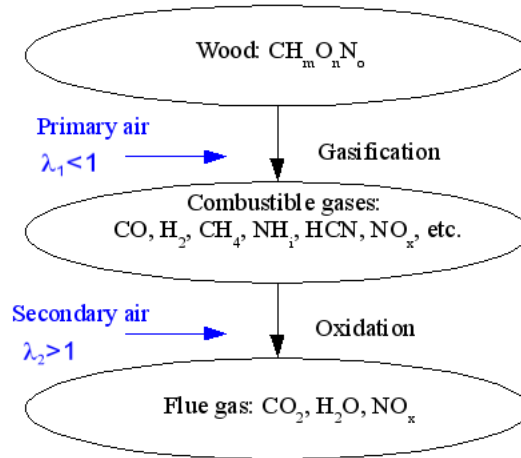

Figure 2.1: Two-staged air combustion [2]

For the gasification process primary air should be added in an under stoichiometric level  $\lambda_1 < 1^1$ . Otherwise the oxidation takes place with primary air where the mixture is not homogenous [2]. During the combustion it is very important that the fuel/air ratio is optimized. The optimum excess air is usually between 1,5 and 2 [14]. Higher excess ratios will decrease the combustion temperature while lower excess air ratios will result in inadequate mixing conditions. If there is too little excess air the carbon monoxide emissions increase considerably as a result of the local shortage of oxygen.

## 2.3 Firing habits in Norway

Norwegians have always used wood as a source heat. However, the firing habits have changed. In the past the houses were poorly insulated and there was always somebody at home that could take care of the fire. Nowadays, nobody can take care of the fire through the night and from the morning to the evening the members of the family are either at school or at work. Furthermore, houses are now well insulated and usually made of wood. Therefore, to get a comfortable temperature at home, less heat output is needed. The tendency is then to fill the stove with a big load of wood and nearly close the air supply so that the average wood consumption is low and the fire lasts longer. This results in low efficiency, high pollutant emission and coating of the chimney with risks of chimney fire [3]. This is the main reason why emissions from wood combustion have become an increasing problem in Norway.

<sup>1</sup> $\lambda$ : Excess air ratio = effectively supplied air/stoichiometric amount of air





# Chapter 3

## Emissions from Wood Combustion

There are numerous pollutants resulting from wood combustion. However, in this chapter, only the ones considered relevant for our project will be discussed. Apart from the pollutants described later in detail, emissions from wood combustion can be also found as nitrogen oxides ( $\text{NO}_x$ ), nitrous oxide ( $\text{N}_2\text{O}$ ), sulphur oxides ( $\text{SO}_x$ ), heavy metals, PCDD/PCDF<sup>1</sup>, etc.

Emissions from wood combustion can be divided into two groups: emissions from complete combustion (oxidized pollutants) and emissions from incomplete combustion (unburnt pollutants). All the pollutants listed above belong to the first of this groups.

As it will be shown later, particle emissions can originate from both complete and incomplete combustion. When the combustion is efficient, almost all organic material is converted to carbon dioxide and water, and few particles are formed (mostly inorganic particles). In contrast, during poor combustion conditions, a lot of particles from incomplete combustion are originated increasing drastically the total amount of emitted particles (now mostly condensed organic matter). This is a significant problem for residential wood combustion, since this kind of appliances are usually poorly operated.

Besides the particles emitted directly from the combustion process (primary particles), secondary particles can originate in the atmosphere as a result of physical or chemical transformations from precursors emitted as gaseous pollutants. The four primary precursors of secondary particles are sulphur dioxide, nitrogen oxides, ammonia and volatile organic compounds (VOCs).

---

<sup>1</sup>Polychlorinated dibenzodioxin and dibenzofuran

## 3.1 Emissions from complete combustion

### 3.1.1 Carbon dioxide (CO<sub>2</sub>)

Like happens with any other carbon-containing fuel, CO<sub>2</sub> is an important product of the combustion of wood. However, emissions from wood combustion are considered to be CO<sub>2</sub>-neutral regarding the global carbon cycle. This is because the CO<sub>2</sub> emitted during the combustion of wood is considered to be equal to the CO<sub>2</sub> absorbed by the trees during the photosynthesis and similar to the amount of pollutant that would be emitted during the natural decay of the wood. This is considered to be the main environmental benefit of biomass combustion and the main advantage of biomass compared to fossil fuels.

### 3.1.2 Particle emissions from complete combustion (ashes)

Ashes are formed during the combustion or gasification of the inorganic material in the wood. They can leave the combustion system as bottom ashes (that stay in the ash pan), fly-ashes or vapour. If not avoided, fly-ashes leave the combustion chamber as particle emissions. Fly-ashes consist of [7]:

- Coarse fly-ashes (particles with a diameter larger than 1  $\mu m$ ), which result from the entrainment in the flue gas of ash and fuel particles from the fuel bed
- Aerosols (particles with a diameter smaller than 1  $\mu m$ ), which are formed from compounds (e.g. salts like KCl, NaCl, K<sub>2</sub>SO<sub>4</sub>)

## 3.2 Emissions from incomplete combustion

Complete combustion would only be possible under ideal conditions. In practice, this never happens and incomplete combustion always occurs to some extent, resulting in added emissions. The main possible causes of incomplete combustion in biomass applications are [7]:

- Inadequate mixing of combustion air and fuel in the combustion chamber, which originates local fuel-rich combustion zones, i.e. local shortage of oxygen
- Overall lack of available oxygen

- Too low combustion temperatures
- Too short residence times

Therefore, optimizing these factors will improve the combustion process resulting in less emissions from incomplete combustion<sup>2</sup>. When sufficient oxygen is available, the combustion chamber temperature is the most important factor due to its exponential influence on the reaction rates as described by the Arrhenius equation:

$$k = A \cdot \exp\left(-\frac{E_a}{R \cdot T}\right) \quad (3.1)$$

$k$  rate constant of an elementary reaction

$T$  absolute temperature

$R$  gas constant

$E_a$  activation energy

$A$  pre-exponential factor

Small-scale wood burning appliances like wood stoves are usually poorly operated, being the high level of emissions from incomplete combustion their main environmental problem.

### 3.2.1 Carbon Monoxide (CO)

CO is an intermediate product of the conversion of fuel carbon to CO<sub>2</sub>. Oxidation of CO to CO<sub>2</sub> comes late in the reaction, after the original fuel and the intermediate hydrocarbons have been consumed and if oxygen is available. Only under ideal conditions, with an excess of oxygen and optimal burning conditions, is carbon completely oxidized to carbon dioxide [10]. The oxidation of CO to CO<sub>2</sub> also requires high combustion temperatures and sufficient retention time, being carbon monoxide a later intermediate than hydrocarbons.

---

<sup>2</sup>Later also referred as primary measures for emission reduction

The amount of carbon monoxide emitted during a combustion process depends on how complete or incomplete the combustion is. This is determined by the excess air ratio  $\lambda$ . From the stoichiometrical point of view a complete combustion is achieved when  $\lambda$  is above 1. As shown in Figure 3.1 CO emission is lowest at a specific excess air ratio (usually between 1,5 and 2). Higher excess ratios will decrease the combustion temperature while lower excess air ratios will result in inadequate mixing conditions [7].

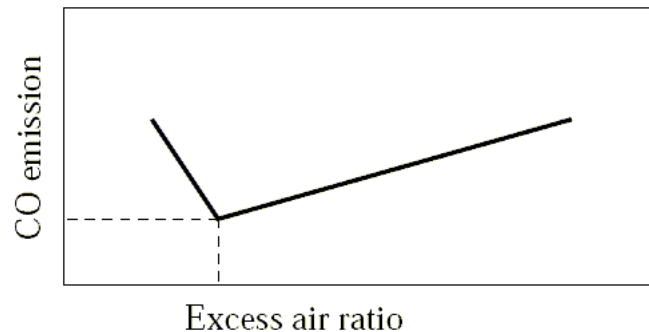

Figure 3.1: CO emission as a function of the excess air ratio  $\lambda$

CO is usually used as an indicator of the combustion quality. High values of CO emitted during a combustion process indicates poor combustion conditions.

### 3.2.2 Volatile Organic Compounds (VOC) and Polycyclic Aromatic Hydrocarbons (PAH)

This section includes all unburnt hydrocarbons except some heavy hydrocarbons that are included in the following section as particle emission because they condense forming tar. Hydrocarbons are intermediate products in the conversion of fuel carbon to  $\text{CO}_2$  and fuel hydrogen to  $\text{H}_2\text{O}$ . They originate before CO in the reaction, which means they have lower emission levels. Unburnt hydrocarbons are a consequence of local flame extinction caused by strain or flame extinction at walls and gaps. VOCs are organic chemicals that evaporate easily whereas PAHs are polycyclic (“many ringed”) hydrocarbons with carcinogenic effects. As for CO, emissions of VOC and PAH are a result of too low combustion temperatures, too short residence time, or lack of available oxygen [7].

Within the aliphatic compounds, methane is the main product. During wood combustion, methane is considered to be formed either by the decarboxylation reaction of acetic acid (see Equation 3.2) or by the decarboxylation reaction of acetaldehyde (see Equation 3.3) [6].

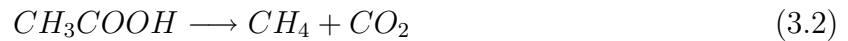

Incomplete combustion of methane may lead to the formation of higher molecular species, such as ethylene and acetylene [6].

The influence of the combustion temperature in the PAH emission level is illustrated in Figure 3.2. If the temperature is low, the formation of PAH is low, and if the combustion temperature is high enough, the formed PAHs are oxidized in the flame [14].

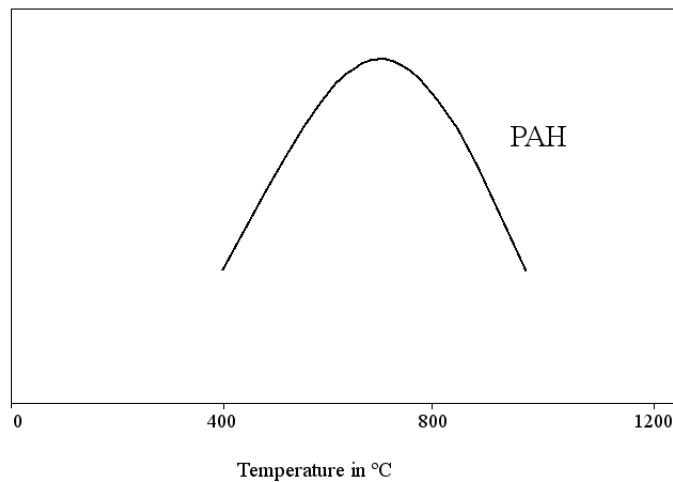

Figure 3.2: Influence of combustion temperature in PAH emissions [7]

The results from a study [5] of non-methane hydrocarbons ( $C_2 - C_8$ ) emissions from wood burning in a wood stove and in a small-scale model (a pot), are illustrated in Figure 3.3. The proportions of the different hydrocarbons are presented in %weight of total non-methane hydrocarbons. The first two columns correspond to the emissions from a wood stove firing birch for initial flaming combustion and during smouldering conditions. The rest of the columns correspond to emissions from the ceramic pot, both burning birch and pine. The study reveals that hydrocarbons are emitted in similar proportions from hardwood and softwood. Moreover, prominent proportions of benzene, which is highly carcinogenic, were found.

	Stove, Birch		Pot, Birch		Pot, Pine
	Flaming	Glowing	Cartridge	Syringe	Cartridge
<b>Alkenes</b>					
C2 Ethene	30	34.7	31.8	32.1	35.5
C3 Propene	4	11.8	8.7	9.0	8.6
C4 <i>trans</i> -2-Butene	0.08	0.66	0.70	0.64	0.42
1-Butene	0.7	1.95	1.74	1.71	1.52
Methylpropene	0.2	1.08	1.09	1.17	0.57
<i>cis</i> -2-Butene	0.07	0.51	0.54	0.50	0.32
C5 Cyclopentene	0.04	0.2	0.2	0.2	0.1
3-Methyl-1-butene	0.05	0.2	0.2	0.2	0.1
<i>trans</i> -2-Pentene	0.06	0.25	0.29	0.27	0.16
2-Methyl-2-butene	0.03	0.32	0.61	0.58	0.11
1-Pentene	0.19	0.37	0.40	0.40	0.35
2-Methyl-1-butene	0.04	0.33	0.33	0.32	0.13
<i>cis</i> -2-Pentene	0.04	0.17	0.19	0.17	0.11
C6 1-Hexene	0.2	0.32	0.33	0.28	0.36
C7 1-Heptene	0.1	0.21	0.20	0.16	0.20
C8 1-Octene	0.1	0.30	0.11	0.09	0.07
<b>Alkadienes</b>					
C3 Propadiene	0.2	0.41	0.4	0.4	0.4
C4 1,3-Butadiene	1.0	2.29	1.81	1.96	1.87
C5 Isoprene	0.1	0.28	0.7	1.1	0.34
Cyclopentadiene	0.4	1.31	1.6	1.7	0.35
<i>trans</i> -1,3-Pentadiene	0.07	0.31	0.32	0.24	0.21
<b>Alkynes</b>					
C2 Ethyne	27	6.8	10.1	11.6	15.0
C3 Propyne	1.0	1.5	1.3	1.3	1.5
C4 2-Butyne	0.04	0.15	0.09	0.07	0.08
Butenyne	0.5	0.40	0.52	0.55	0.71
1-Butyne	0.09	0.14	0.13	0.12	0.16
<b>Alkanes</b>					
C2 Ethane	5	14.1	10.5	10.6	10.4
C3 Propane	0.4	3.0	2.8	2.8	2.3
C4 Butane	0.1	0.7	0.7	0.7	0.9
C5 Methylbutane	0.05	0.07	0.07	0.07	0.05
Pentane	0.1	0.22	0.8	1.1	0.4
C6 Hexane	0.03	0.08	0.17	0.16	0.14
<b>Arenes</b>					
C6 Benzene	20	7.4	11.0	10.0	9.2
C7 Methylbenzene	3	3.2	3.9	3.1	2.4
C8 Ethylbenzene	0.5	0.4	0.55	0.42	0.8
Dimethylbenzenes	0.7	0.9	1.29	1.0	1.0
Styrene	1.0	0.6	1.01	0.70	0.9

Figure 3.3: Hydrocarbons from wood burning (%weight)

All hydrocarbons contribute indirectly to the greenhouse effect through the formation of ozone ( $O_3$ ). Furthermore, methane ( $CH_4$ ) is a direct greenhouse gas with a global warming potential of 21<sup>3</sup>. Hydrocarbons also cause negative effects on the human respiratory system.

### 3.2.3 Particle emissions from incomplete combustion

Particle emissions from incomplete combustion can be found as soot, char or condensed heavy hydrocarbons (tar droplets). Soot is an agglomeration of carbon particles, which is a result of a local lack of oxygen in the flame zone and/or local flame extinction. Char particles may be entrained in the flue gas due to their very low specific density, especially at high flue gas flow rates. Condensed organic matter is an important, and in some cases the main, contributor to the total particle emission level in small-scale biomass combustion applications such as wood stoves. Their contribution is even higher during poor combustion conditions.

<sup>3</sup>Calculated over 100 year time horizon

As for CO, emissions of particles may be a result of low combustion temperatures, short residence times or lack of available oxygen. However, due to the diversity of particle emission components, reducing particle emission levels by primary measures is not as straightforward as it is for CO, except for particles consisting of condensed heavy hydrocarbons [7]. A higher combustion temperature, for example, reduces the density of the particles. This makes easier for the them to leave the combustion chamber entrained in the flue gases.

### 3.3 Influence of particle sampling

The particle emissions may consist of a filterable (solid fraction) and a condensable fraction. Especially under unfavourable combustion conditions in wood burning appliances, the flue gas contains organic compounds which condense at ambient temperature originating new particles. In this situations, the amount of particle emission measured depends on the location of the measurement, i.e. the state of the flue gas at that location.

There are two main ways of measuring particle emission from wood combustion:

- Sampling particles on a heated filter, from undiluted hot flue gas in the chimney (above the dew point of the gas)
- Sampling particles after cooling and diluting the flue gas using a dilution tunnel (below the dew point of the gas), resulting in condensation of organic tar compounds.

The lower the temperature in the sampling point is, the more compounds will condense to liquid phase originating new particles (liquid particles) that will be also collected in the filter. Thus, more compounds will be found in liquid phase at sampling in the dilution tunnel compared with sampling in the hot flue gas and higher particle emission is expected at this location.

Sampling in the chimney means collecting only the liquid particles with a dew point above the measurement point, which are really few since the temperature of the flue gases in this measurement point is high. In order to detect both the filterable and the condensable fraction the measurement should be done after diluting and cooling the flue gas.

### 3.4 Particulate Matter

Particulate Matter (PM) describes the sum of airborne solid particles and droplets. The main sources of atmospheric particulate matter in Europe are residential wood combustion and transport (especially diesel engines), but particles also originate from road abrasion (especially during the winter due to the use of spikes), handling of raw materials, etc. However, fine particles are mostly originated through combustion processes. EPA<sup>4</sup> groups particle pollution into two categories:

- “Coarse Particles” (PM<sub>10-2.5</sub>) such as those found near roadways and dusty industries range in diameter from 2,5 to 10  $\mu m$ . The existing “coarse” particle standard (known as PM<sub>10</sub>) includes all particles and droplets with an aerodynamic diameter smaller than 10  $\mu m$ . EPA has proposed replacing this standard with one that includes only particles between 10 and 2,5  $\mu m$  in size (PM<sub>10-2.5</sub>).
- “Fine Particles” (PM<sub>2.5</sub>) such as those found in smoke and haze have diameters less than 2,5  $\mu m$ . PM<sub>2.5</sub> is referred to as “primary” if it is directly emitted into the air as solid or liquid particles, and is called “secondary” if it is formed by chemical reactions of gases in the atmosphere.

Since particulate matter with a diameter smaller than 10  $\mu m$  penetrates into the human thorax (PM<sub>10</sub> is considered as the inhalable fraction) the European Community has established limits for PM<sub>10</sub> in the air (Directive 1999/30/EC) that became effective in 2005 within its member states (see Table 3.1). In the first phase the limit for the yearly average is 40  $\mu m/m^3$  and for the daily average (24 hour mean) 50  $\mu m/m^3$ . The daily average can not be exceeded more than 35 times per year. In the second phase, starting in 2010, the yearly average restriction will be 20  $\mu m/m^3$  and the allowed number of yearly exceedances for the daily average will be reduced to 7.

In Norway the limit for the yearly average is set to 35  $\mu m/m^3$  whereas the daily average limit is also 50  $\mu m/m^3$ . To meet these clean air requirements, authorities will have to promote measures to reduce the different sources of particulate matter to the air.

Residential wood combustion is an important source of particulate matter to the air, especially in the Nordic countries where it contributes to a large share of the total PM emissions.

---

<sup>4</sup>USA Environmental Protection Agency



	Annual limit value ( $\mu m/m^3$ )	24 hours limit value ( $\mu m/m^3$ )	Allowance for 24 hours limit value
EC (phase 1)	40	50	35 exceedances per year
EC (phase 2)	20	50	7 exceedances per year
Norway	35	50	

Table 3.1: Immision limit values for  $PM_{10}$  [4]

Most of the particles emitted from wood combustion are fine particles with a diameter smaller than  $1 \mu m$ , usually in the range of 30 to 300  $nm$  [19]. Nowadays,  $PM_{10}$  is used as air quality indicator. However, due to its adverse effects on human health, future restrictions also on  $PM_{2.5}$  are expected.

### 3.5 Particulate matter effects on Human health

Atmospheric particulate matter causes serious effects on human health. Several epidemiological studies show a relation between long-term exposure to particulate matter and: increased hospitalization for respiratory and heart disease, lung cancer death rates, reduced lung function, exacerbation of asthma, etc. Particles are also carriers of toxic substances like benzene or PAH, with carcinogenic effects.

The main determinant of health effects is the particle size.  $PM_{10}$  is considered to be the inhalable fraction, since larger particles are usually filtered in the nose or throat. However, the smallest particles ( $PM_{2.5}$ ) are of most concern, since they can penetrate deeply into the human respiratory system inflaming the lungs alveoli. Fine particles ( $PM_{2.5}$ ) are strongly associated with mortality and hospitalization for cardio-pulmonary disease [WHO<sup>5</sup>]. Fine particles also remain longer in the atmosphere. This means that the size distribution of the emissions is different from that of the exposure, because the most dangerous fractions are more persistent.

---

<sup>5</sup>World Health Organization

## 3.6 Measures for particle emission reduction

The measures for particle emission reduction in biomass combustion applications can be divided into two groups:

- Primary measures: optimizing the combustion conditions with respect to combustion temperature, mixing and residence time generally contributes to a reduction in the emissions from incomplete combustion.
- Secondary measures: filtration devices like baghouse filters or ESPs<sup>6</sup> could be use to reduce the emissions further. However, this measures are not cost-effective for small-scale applications yet.

Furthermore, consumer information promoting adequate operation and maintainance of the appliance, as well as the use of quality fuel, is fundamental in the task to reduce particle emissions from wood combustion.

---

<sup>6</sup>Electrostatic precipitators

# Chapter 4

## The Standards

European clean air requirements are getting stricter on particulate matter, forcing the European countries to reduce its different sources to meet this requirements. Since residential wood combustion is a relevant source of particulate matter to the air , further development of wood stoves is necessary in order to reduce their particle emissions.

The standards and test procedures are fundamental in the task to get low emission stoves. Several countries have already introduced national standards for emission testing and certification of wood stoves. However, these standards are very different in the way the emissions are measured, the test facility used, etc. This makes difficult to compare the emission results from tests performed according to different standards and it can result in confusion regarding the environmental evaluation and acceptance of stoves. Different standards, laboratories and measurements can result in different evaluations and conclusions of the emissions from the same stove [9]. The introduction of a common European standard for emission testing of wood stoves would help to solve this problems, supporting the development of environmentally-friendly appliances.

In this chapter the situation in Europe regarding this matter will be explained, focusing on particle emission measurement methods. The main test methods for this purpose will be described and the differences between them will be addressed.

Firstly, the EN-13240 standard will be presented. Although this standard does not deal with particle emission measurements and requirements, it establishes the basic emission requirements that every stove has to fulfil to enter the market in Europe.

Nowadays, there are three official methods for measuring particle and dust emissions in Europe:

- The combined Austrian-German method (see 4.2)
- The Norwegian method (see 6.3)
- The UK method (see 4.3)

A country without a national method for this purpose can choose to apply any of this three methods. Secondly, the combined Austrian-German method and the UK method will be described.

It seems difficult to reach an agreement to obtain a common European method for particle emission testing of wood stoves from the different methods provided by the national documents of those countries that have their own method. The CEN<sup>1</sup> tasks for this purpose will be presented next.

Finally, the EPA method for particle emission testing will be described.

## 4.1 EN-13240

The European standard for roomheaters fired by solid fuel is the most commonly used method for stove testing and certification in Europe. It establishes the basic requirements that a stove has to fulfil to enter the market. The main requirements are efficiency and CO emission but stoves must be also safe and sound, have thorough instruction manuals and be labelled with the efficiency, heat output and CO emission on each recommended fuel. Type tests are performed at nominal heat output and constant flue draught pressure following the manufacturer's recommendations regarding the test fuel, the burning rate and the combustion controls settings to be used to achieve the claimed nominal heat output during the test. The standard allows individual states to add extra requirements, for instance for higher efficiency or smoke reduction, if they wish.

---

<sup>1</sup>European Committee for Standardization

### 4.1.1 Description of performance test at nominal heat output

The test consists of three test periods preceded by a pre-test. The refuelling interval between these three test periods should not be less than 45 minutes and the fuel load for each of this three test periods is calculated with the following equation [20] :

$$B_{fl} = 360.000 \times \frac{(P_n \times t_b)}{(H_u \times \eta)} \quad (4.1)$$

Where:

$B_{fl}$  is the mass of fuel load, in kg

$H_u$  is the lower calorific value of the test fuel, on a fired basis, in kJ/kg

$\eta$  is the minimum efficiency according to this appliance standard or a higher value declared by the manufacturer, in %

$P_n$  is the nominal heat output, in kW

$t_b$  is the minimum refuelling interval, in hours, or duration as declared by the manufacturer

### 4.1.2 Requirements for performance test at nominal heat output

- Carbon monoxide emission: the mean carbon monoxide contents of the dry combustion gases shall be less than 1 % (related to 13% oxygen content in the flue gases).

Requirements on appliances with closed doors	
Class	% CO emission class limits (at 13% O <sub>2</sub> )
1	≤ 0.3
2	> 0.3 ≤ 1.0

Table 4.1: Carbon monoxide emission requirements [20]

- Efficiency at nominal heat output: the average thermal efficiency calculated from the mean of at least two test results at nominal heat output shall be higher than 50 %.

Requirements on appliances with closed doors	
Class	Efficiency class limits (%)
1	$\geq 70$
2	$\geq 60 < 70$
3	$\geq 50 < 60$

Table 4.2: Efficiency requirements at nominal heat output [20]

- Flue draught: The flue draught (the static pressure to be applied in the measurement section) shall be 12 Pa for stoves with nominal heat output smaller than 25 kW. The flue static pressure shall be kept within  $\pm 2$  Pa of the specified value.

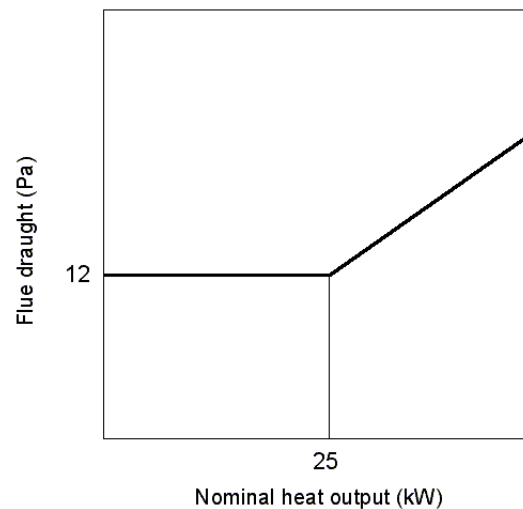

Figure 4.1: Flue draught values

## 4.2 German - Austrian particle test method

Germany has no requirements on dust emissions from wood stoves. However, during EN-13240 type tests, dust measurements are often performed on a voluntary basis according to the specifications of the German quality label “DIN plus” with measurements according to the VDI<sup>2</sup> 2066 part 1 (gravimetric measurements from undiluted exhaust gas). This method uses the sampling train shown in Figure 4.2 to withdraw a sample of the flue gas directly from the chimney (without using a dilution tunnel) and collect the particles from that sample in a glass fibre filter.

---

<sup>2</sup>Verein Deutscher Ingenieure

The filter system is shown in Figure 4.3. The temperature in the filter area shall be maintained at 70 °C to avoid the dew point of the sampled gas. The test is carried out at nominal heat output.

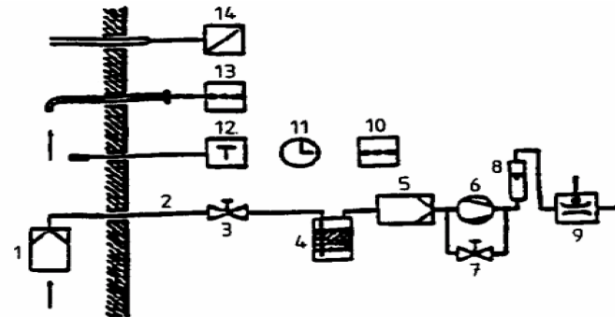

- 1 Tubular filter with probe and diffuser
- 2 Suction tube
- 3 Shutoff device
- 4 Drying tower, if necessary
- 5 Protective filter for pump
- 6 Pump (gas-tight)
- 7 Regulating by-pass
- 8 Rotameter
- 9 Gas volume meter with thermometer
- 10 Barometer
- 11 Stop watch
- 12 Thermometer
- 13 Prandtl-type Pitot head with micromanometer, alternatively anemometer
- 14 Gas analyser, if necessary

Figure 4.2: Sampling train according to VDI 2066 [24]

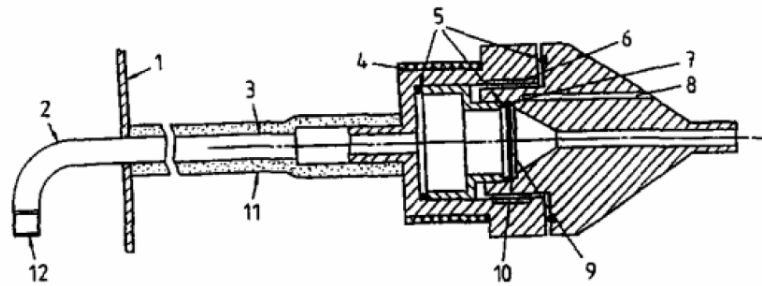

- 1 Dilution tunnel wall
- 2 Stainless steel tubing
- 3 Sampling probe
- 4 Heater band
- 5 O-ring seals
- 6 Threaded coupling
- 7 Filter Ø 47
- 8 Thermocouple pocket
- 9 Ø 44 x 1.5 thick perforated support disc with 109 x Ø 2.2 equi-spaced holes on triangular pitch
- 10 Ø 47 x 0.4 thick perforated filter support disc with 109 x Ø 0.55 equi-spaced holes on triangular pitch
- 11 Insulation
- 12 M12 threaded end for nozzle attachment

Figure 4.3: Filter system according to VDI 2066 [24]

Austrian laws demand to measure particle emissions from wood stoves at nominal heat output and to report them as mg/MJ. The method used in Austria also measures the particles directly in the chimney according to the German method VDI 2066. The filter can be fitted

either inside or outside the chimney. If the filter is placed outside the chimney its temperature shall be maintained at 70 °C.

### 4.3 United Kingdom particle test method

UK has restrictions if an appliance is submitted for consideration towards exception for use in smoke control areas under Clean Air Act 1993, which laid down requirements regarding emissions from solid fuel burning appliances. The Department of Environment would require it to lie within the smoke emission limits set out in the British Standards document PD 6434 [9]. The document deals with the design and testing of smoke reducing solid fuel burning domestic appliances. Smoke is here defined as “including soot, ash, grit, gritty particles and fume emitted in smoke”. PD 6434 sets a smoke emission limit that can be expressed as 5 g/h + 0,1 g/h per 0,3 kW of the corresponding mean heat output (wood with 12-16% moisture content) [27]. As shown in Figure 4.4 a small electrostatic precipitator fitted in the top of the chimney is used to collect and measure the smoke from domestic appliances tested under laboratory conditions. Moreover, the optical density of the smoke is monitored during the whole test run.

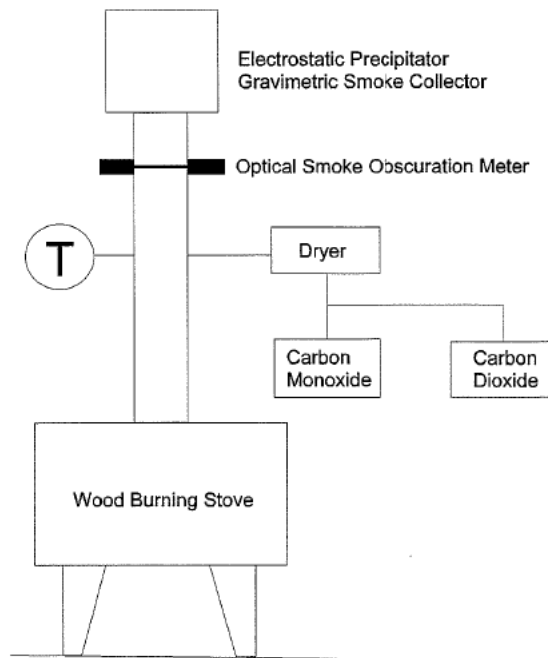

Figure 4.4: Test facility used in The United Kingdom [9]



## 4.4 CEN tasks for a common particle emission test method

Since the EN-13240 Standard does not include particle emission measurements the CEN has been working lately in a common European standard for the test method to be used for this purpose. The most important features of this method will be presented next. The method is based on gravimetric particulate emission measurement collecting the entire flue gas flow under constant volume sampling (CVS) conditions by means of a dilution tunnel [19]. The proposed test facility is shown in Figure 4.5. The test would be carried out parallel to an EN-13240 type test. The flue gas coming out from the stack is collected in a movable telescope type cowl and diluted with ambient air before entering the dilution tunnel. A bypass supplies the dilution tunnel with the extra ambient air needed to achieve the required dilution ratios.

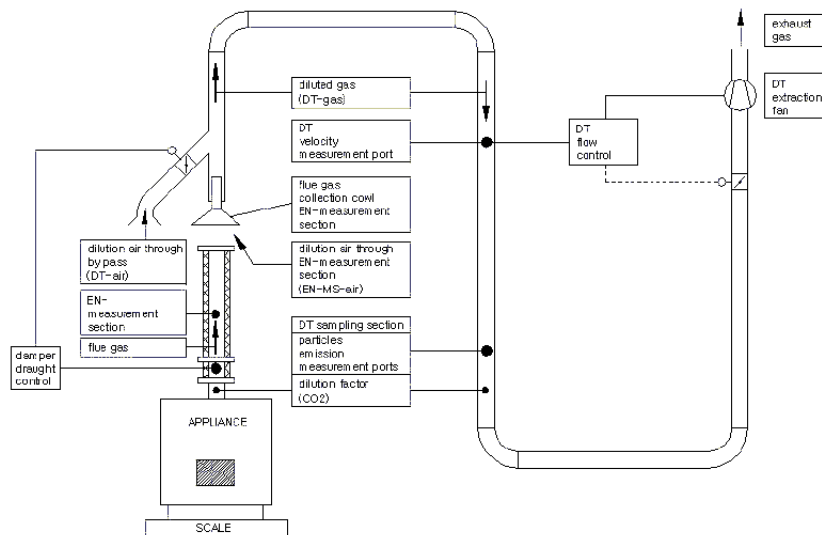

Figure 4.5: CEN proposed test facility

The required draft in the stack (according to the EN-13240) can be roughly obtained, during the pretest, changing the gap between the cowl and the top of the stack and can be adjusted afterwards changing the inclination of the damper fitted in the air bypass duct. In the bottom of the dilution tunnel a sample of the diluted gases is withdrawn at constant flow into a sampling train (see Figure 4.6) so that particles from that sample can be collected in a filter unit for subsequent gravimetric analysis. An extraction fan fitted after the particulate matter measurement section carries the diluted gases from the cowl to the exhaust, evacuating them outside the test facility.

The dilution tunnel gas flow should be maintained in the range of 3 to 10 m/s to meet the required dilution ratios of between 10 and 20 for the different burning rates [19]. Therefore, it should be possible to regulate the speed of the fan controlling the flow rate in the dilution

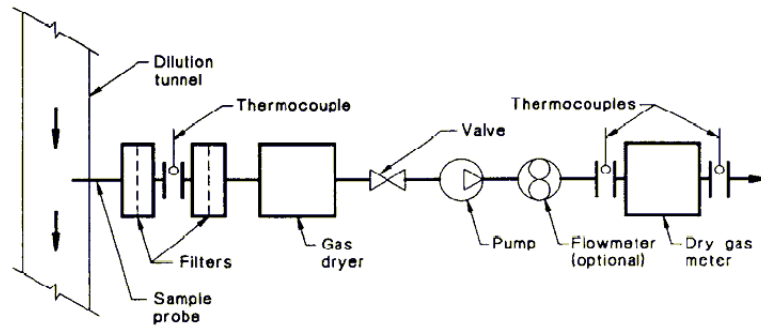

Figure 4.6: CEN proposed sampling train [19]

tunnel to meet the required dilution ratio at the respective burning rate. The ratio of the dilution tunnel gas flow and the appliance flue gas flow shall be obtained from the  $\text{CO}_2$  concentration in both sides. The ratio of the  $\text{CO}_2$  concentration in the dilution tunnel and in the flue gas in the stack defines the dilution ratio.

## 4.5 U.S.A particle test method

Wood burning stoves to be sold in the United States must be certified by the U.S. Environmental Protection Agency (EPA). Certification is required before a wood-burning stove model line can be offered for sale. For the EPA to certify a wood-burning stove, the stove must be tested for emissions by an EPA-accredited testing laboratory. The EPA method 5G is used for determination of particle emissions from wood stoves. The test facility used is shown in Figure 4.7. The measurements are done using a dilution tunnel and the firing procedures are determined by method 28. Testing consists of sampling air emissions during the burning of four separate fuel loads, each burned at a different burning rate. The measurements done at four different average wood consumptions provide information about the emissions from the stove at the whole range of firing rates (from low to high firing rates). The filter system used for collecting the particles should be maintained at a temperature below  $32\text{ }^\circ\text{C}$  [25].

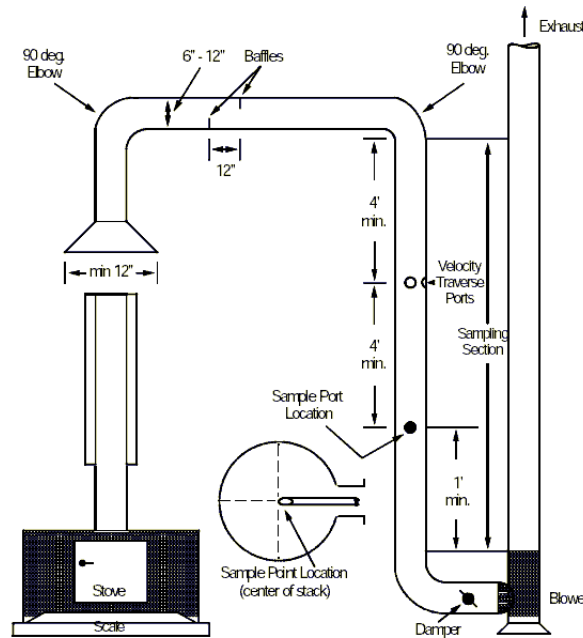

Figure 4.7: Test Facility used in EPA method 5G (USA) [25]

There are substantial differences between the U.S. EPA emissions standard and those found in most European countries, especially as compared to the Deutsch Industry (DIN) test standards. However, the U.S method has many things in common with the Norwegian method and emission results from both standards should be comparable. The method gives four values of particle emissions measured in g/h. Each of these measurements shall be within one of the different average wood consumption rates shown in Table 4.3.

Category	1	2	3	4
Average wood consumption (kg/h)	< 0,8	0,8 – 1,25	1,25 – 1,9	> 1,9

Table 4.3: Average wood consumption rates for method 5G (USA) [26]

From these four values a weighted value of particle emission is calculated. The particle emission limit is 4,1 g/h (dry basis) for catalytic stoves/fireplaces and 7,5 g/h (dry basis) for non-catalytic stoves/fireplaces. The state of Washington has a lower limitation of 4,5 g/h.



# Chapter 5

## The Stove: Jøtul F3

In this chapter the stove used during the tests will be presented. The catalog name of the stove is Jøtul F3. Jøtul AS is a Norwegian company that since 1853 manufactures wood stoves and fireplaces. Jøtul AS works closely with Sintef and NTNU to develop measures for emission reduction from wood combustion. The company supported the project with a new Jøtul F3. Jøtul F3 is an improved version (including a secondary combustion system) of Jøtul 3, that has been in use in Norway since it was first produced in the 80's.

### 5.1 Main features of the stove

Jøtul F3 is a cast iron stove. The stove is equipped with a glass door leading to heat losses through radiation and resulting in a lower temperature in the combustion chamber. The stove is wider than long. The dimensions of the combustion chamber are 0.21 x 0.48 x 0.21 m<sup>3</sup> giving a chamber volume of 0.02117 m<sup>3</sup>. The desired wood weight ranges between 2.14 kg and 2.6 kg according to the Norwegian Standard, which states that the fuel charge density must be within  $(112 \pm 11)$  kg/m<sup>3</sup> of the test fuel usable firebox volume [21].

The stove benefits from the advantages of a two-staged combustion. The combustion process is divided in two stages; gasification of the wood with primary air and oxidation of the combustible gases with secondary air. The air flow pattern inside the stove is shown in Figure 5.1. The primary combustion air is coming from the top of the door allowing a better heat exchange and keeping the glass door clean. The air goes first down toward the wood and moves then out of the stove across the secondary air system leading to a longer retention

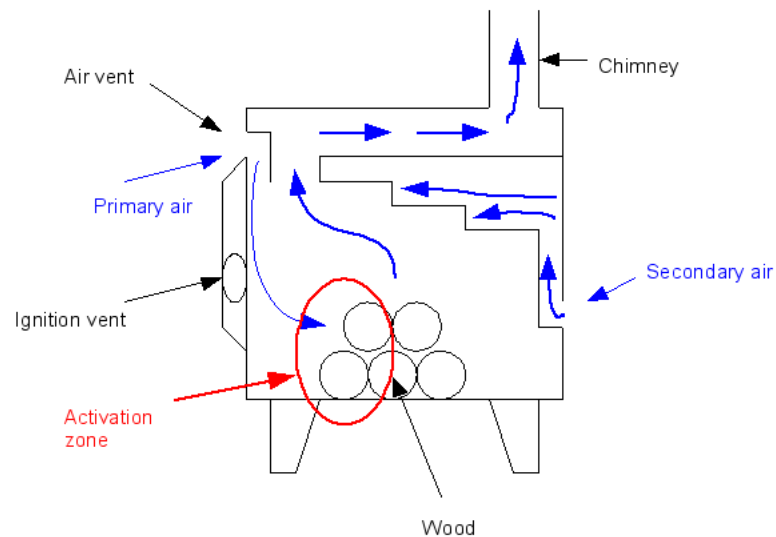

Figure 5.1: Air flow pattern inside the stove

time of the gases in the stove. The secondary combustion system brings secondary air from the back of the stove to the combustion chamber.

As shown in Figure 5.2 the secondary air is getting into the stove from two rows of holes, each row with 25 holes with a diameter of 3 mm making a total area of secondary air of  $0.00035343 \text{ m}^2$ .



Figure 5.2: Secondary air system

Thanks to this secondary air, the flue gases and toxic particles that would otherwise go up the chimney can be ignited again leading to a better burnout and lower particle emission. The dual “clean burn” system converts up to 90% of the gases and particles in the smoke into heat and increases the efficiency by 40% [29].

## 5.2 Activation zone

Jøtul F3 is wider than long. The reason for this design is that the customer can easily watch the fire through the glass door. The design of the stove influences the burning characteristics. The activation zone is the zone where the burning takes place. This zone starts in the front of the stove (where the primary air inlet is) and moves slowly toward the end of the stove. The wood burns fast in the part close to the front of the stove since the air can easily reach the wood. However, the further back the activation zone moves toward the end of the stove the lower the burning rate becomes due to the difficulties for the air to get to the rear part of the stove. Due to this feature, most of the charcoal can be found in the back of the stove. For the same reason more ash will be found in the front part of the stove than in the back. The activation zone in this kind of stove is bigger than in a stove longer than wide, resulting in higher burning rates for Jøtul F3. Thus, it is more difficult to achieve low burning rates for wider stoves. The primary air supply has to be lower for wider stoves in order to get the same low burning rate as for the longer stoves. Therefore, since at low burning rates the air coming in will be less, the oxygen supply will be lower and there will be more emissions. The particle emission will be higher at low burning rates for Jøtul F3 than for longer than wide stoves.

## 5.3 Stove's air vents

As shown in Figure 5.3 the product has two vents: the “air vent” and the “ignition vent”.

The “air vent” regulates the primary combustion air. It is used to control the combustion rate of the wood, i.e. the burning rate. Opening the “air vent” will allow more air to the combustion chamber and the burning rate will increase. Thus, the wood will burn faster. The “ignition vent” is only used during the ignition phase, helping the ignition process by feeding air directly to the fire.



Figure 5.3: Front view of Jøtul F3 with both air vents

## 5.4 Wood consumption and nominal heat output

The technical data of the stove is presented in Table 5.1. Jøtul F3 has a nominal heat output of 6,0 kW. To achieve the claimed nominal heat output, the manufacturer recommends the use of wood with a nominal heat emission of approx. 2 kg/h, opening the air vent almost completely [28].

Flue dimension	Ø 150 mm/ 177 cm <sup>2</sup> cross section
Operating range	3,4 – 9,0 kW
Nominal heat output	6,0 kW
Flue gas mass flow	5,3 g/sec
Recommended chimney draught	11 Pa
Efficiency	78% at 6,8 kW
CO emission (13% O <sub>2</sub> )	0,05 %
Flue gas temperature	328 °C
Operational mode	Intermittent

Table 5.1: Technical data according to EN-13240 [28]



The recommended fuel consists of logs of birch or spruce with a water content of approx. 20%. The amount of energy produced by 1 kg of quality wood is about 3,8 kWh [28]. A very important factor for the correct consumption of the fuel is that the logs have the correct size. According to the manufacturer the size of the logs should be as described in Table 5.2.

Kindling	
Length	20-30 cm
Diameter	2-5 cm
Amount per fire	6-8 pieces
Firewood (split logs)	
Length	30 cm
Diameter	8 cm
Intervals for adding wood	approx. every 60 min.
Size of the fire	2 kg
Amount per load	2 pieces

Table 5.2: Recommended fuel size [28]



# Chapter 6

## The Test Facility and the Measurements

In this chapter the test facility and the measuring equipment will be described. Some figures will clarify where and how the different measurements were performed. Furthermore, the main features of the Norwegian Standard will be presented, along with the description of the procedure for running a test according to this standard. Some tests were also performed following the requirements of the EN-13240. Finally, the peculiarities of this tests will be shown.

### 6.1 The test facility

The test facility stands in the Laboratory of Thermal Energy of the Department of Energy and Process Engineering and was built according to the Norwegian Standard requirements (see Figure 6.1). It consists of a scale where the oven stands, the stack and the dilution tunnel. The stack consists of an insulated steel pipe with an interior diameter of 20 cm and approx. 4,5 m of height. The flue gases coming out from the stack are collected in a hood, where they are diluted by mixing with ambient air. After crossing the dilution tunnel, the diluted and cooled gases are evacuated from the test rig.

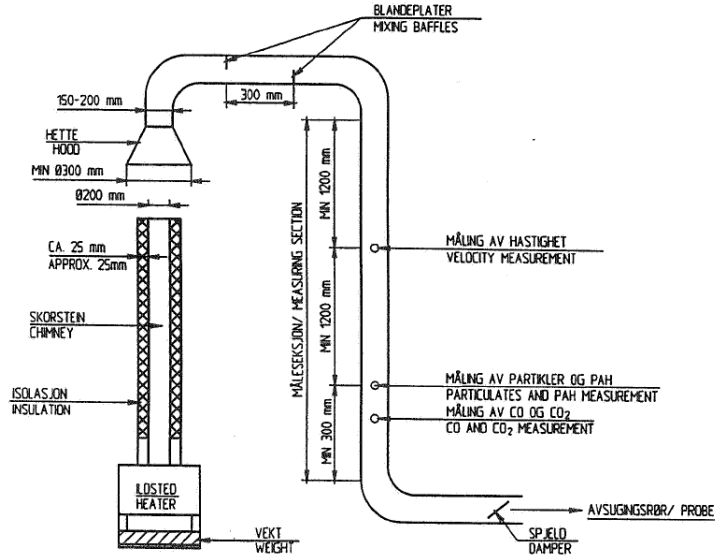

Figure 6.1: Test facility according to the Norwegian standard [22]

## 6.2 The measurements

Figure 6.2 and Figure 6.3 show the most relevant measurements performed in the stack and in the dilution tunnel.

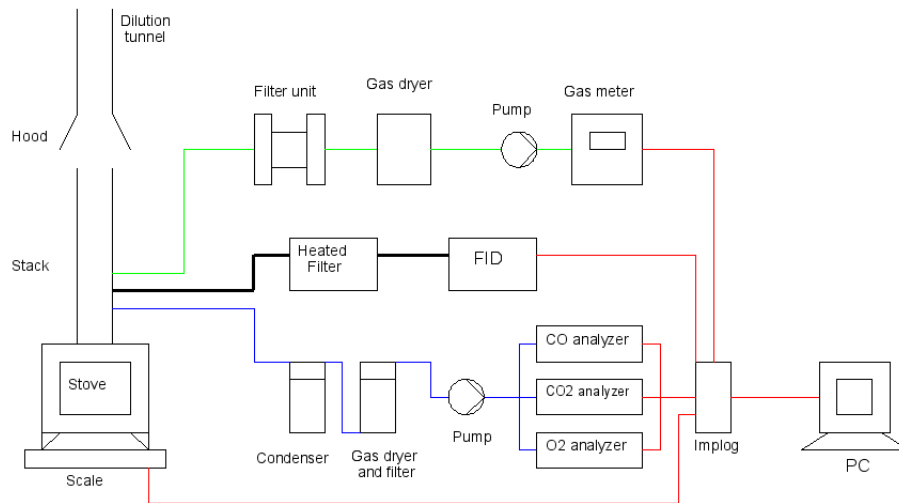

Figure 6.2: Measurements in the stack

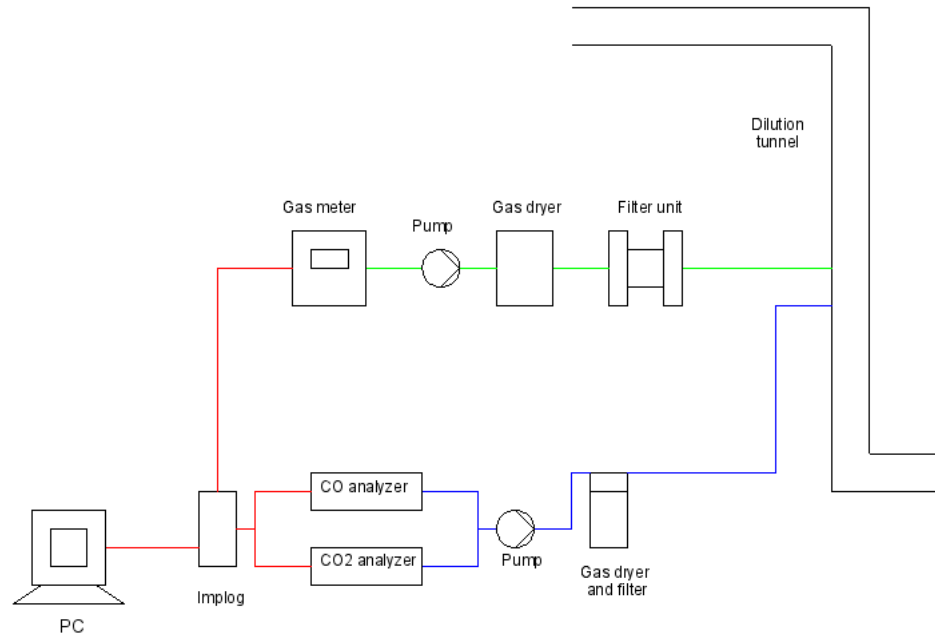

Figure 6.3: Measurements in the dilution tunnel

The measuring equipment consists of several thermocouples, two continuous infrared analyzers (IR-analyzers), an oxygen analyzer, a Flame Ionization Detector, a pressure gauge, a pitot tube and an electronic scale.

Measurement	Device	Output Signal	Effective Range	Measurement accuracy
Temperature	Thermocouple	0 – 50 mV	0 – 1200 °C	$\pm 1.5$ °C (-40 -375°C $\pm 0.004 \cdot T$ , over 375 °C)
Weight	Mettler PE 240	0 – 10 V	0 – 240 kg	$\pm 10$ g
Pressure in the chimney	PC	0 – 10 V	0 – 1 mbar	$\pm 0.01$ mbar

Table 6.1: Measuring equipment

To measure the negative pressure in the flue gas outlet, a probe has been introduced inside the stack at approx. 17 cm from the top surface of the stove. The probe is connected to a pressure gauge. A pitot tube has been fitted in the top of the dilution tunnel (see velocity measurement section in Figure 6.1) to measure the velocity of the diluted flue gas in the tunnel, which mean value has to be 3,33 m/s according to the Norwegian standard [22]. This value is achieved regulating the speed of the small fan fitted at the end of the dilution tunnel.

The fan extracts the gases from the dilution tunnel making possible to achieve the required velocity and the appropriate dilution rate. The location of the thermocouples is shown in Table 6.2.

Thermocouples
Inside stove (above the fuel)
Back surface stove
Top surface stove
Bottom surface stove
Right surface stove
Left surface stove
Top dilution tunnel
Bottom dilution tunnel
Gas watch sampling train
Pitot tube
Bottom of the stack (flue gas)
Top of the stack
Filter holder stack
Filter holder dilution tunnel
Room temperature

Table 6.2: Location of thermocouples

Every device sends a signal to an “implog box” that converts the signal and forwards it to the PC. The different measurements have been recorded each minute during the test run.

### 6.2.1 CO, CO<sub>2</sub> and O<sub>2</sub> measurements in the stack

A sample of the flue gases is withdrawn from the stack through a steel probe. As it can be seen in Figure 6.4 the flue gas goes through several devices before reaching the analyzers. Firstly, the water is removed in a condenser. Secondly, the gas is dried with silica gel and filtered by means of a filter located in the top of the gas dryer. Finally, after going through the pump the flue gas reaches the analyzers.

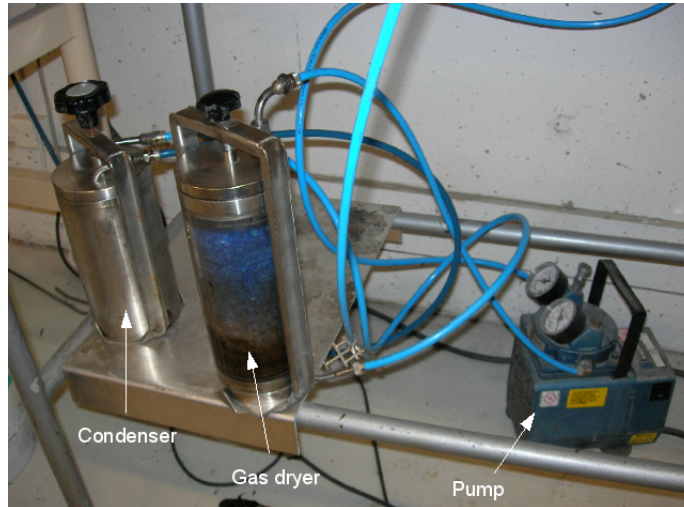

Figure 6.4: Stack flue gas measuring unit

The silica gel and the filter have to be changed from time to time. The characteristics of the flue gas analyzers used in the stack are shown in Table 6.3.

Measurement	Device	Output Signal	Effective Range	Measurement accuracy
Volume fraction O <sub>2</sub>	Sybron Taylor Servomex, OA 500	0 – 10 V	0 – 25 vol%	± 0.25 vol%
Volume fraction CO <sub>2</sub>	Hartmann Braun Uras 10 E	0 – 10 V	0 – 20 vol%	± 0.4 vol%
Volume fraction CO	Hartmann Braun Uras 10 E	0 – 10 V	0 – 5 vol%	± 0.1 vol%

Table 6.3: Gas analyzers used in the stack

### 6.2.2 CO and CO<sub>2</sub> measurements in the dilution tunnel

CO and CO<sub>2</sub> measurements in the dilution tunnel are performed similarly as in the stack. The only difference is that the analyzer has to be more accurate (as it can be observed in Table 6.4) because in the dilution tunnel the flue gas is diluted approx. 10 times and this means that the quantity of CO and CO<sub>2</sub> will be more or less 10 times lower than in the stack. In fact, the dilution ratio has been obtained from the relation between the concentration of CO<sub>2</sub> in the stack and in the dilution tunnel.

Moreover, the dilution ratio has been used to calculate the velocity of the flue gases in the stack, dividing the velocity of the flue gases in the dilution tunnel (obtained from the pitot tube) by the average dilution ratio. The equipment used to withdrawn the flue gas is similar to the one shown in Figure 6.4 but without the condenser.

Measurement	Device	Output Signal	Effective Range	Measurement accuracy
Volume fraction CO <sub>2</sub>	Hartmann Braun Uras 10 E	0 – 20 mA	0 – 5 vol%	± 0.1 vol%
Volume fraction CO	Hartmann Braun Uras 10 E	0 – 20 mA	0 – 500 ppm	± 10 ppm

Table 6.4: Gas analyzers used in the dilution tunnel

### 6.2.3 Particle measurements in the stack and dilution tunnel

The equipment used for this purpose is the same for the stack and for the dilution tunnel. The gas is withdrawn proportionally from the flue gas by means of a pump that forces it to go through the filter holder where a glass fibre filter collects the particles for subsequent analysis. After being dried, the withdrawn gas is recorded in the gas meter. The filters are weighed before and after the test run to obtain the mass of pasticles collected. The sampling train is shown in Figure 6.5.

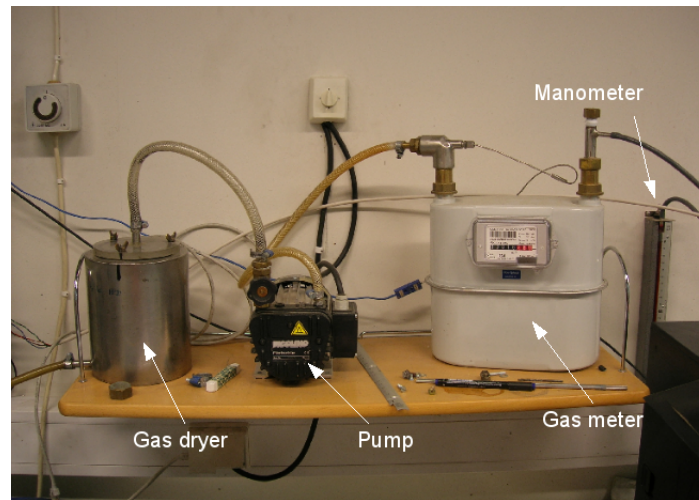

Figure 6.5: Sampling unit for particle measurements

An electrical trace have been fitted around the stack's filter holder keeping it at an average temperature of approx. 170 °C during the test run, avoiding condensation of organic matter.



Since we are measuring the hydrocarbons separately with the Flame Ionization Detector, if condensation is allowed we would be measuring them twice. Furthermore, according to the Norwegian standard the dilution tunnel filter holder gas temperature shall be kept below 35 °C [22], to ensure that condensable organic matter is sampled.

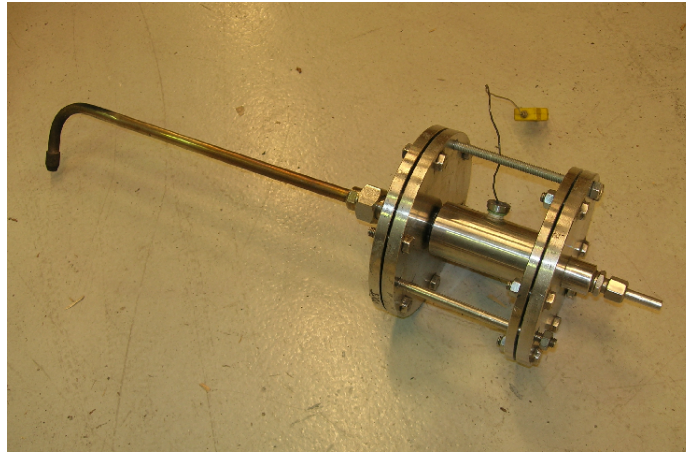

Figure 6.6: Filter holder

#### 6.2.4 Hydrocarbons measurement in the stack

For measuring the hydrocarbons in the flue gas a Flame Ionization Detector (FID) has been used. The device gives the Total Hydrocarbon Content (THC) in the flue gas expressed in ppm of propane ( $C_3H_8$ ) equivalents but does not give any specific information about the separate constituents. The measurement is continuous (each minute). The measurement system consists of a heated sample line, a heated filter to remove particles from the sample and a Flame Ionization Detector. Both sample line and filter are heated up to 180 °C, protecting the system against the formation of tar.

Measurement	Device	Output Signal	Effective Range	Measurement accuracy
Total Hydrocarbon Content in the chimney	Signal Model 3000 Hydrocarbon Analyzer	0 – 10 V	0 – 100 ppm	± 2 ppm

Table 6.5: Flame Ionization Detector (FID)

## 6.3 The Norwegian Standard

In Norway measurements of particle emissions from wood stoves are done according to the Norwegian Standard. A test is always preceded by a pretest, which is used to achieve the basic firebed in the stove and to heat up the stove to facilitate a thermal balance during the test run. The difference between the mean value of the wood heater surface temperature at the beginning and completion of the test run shall not be greater than 70 °C [21]. The pretest has to last at least for one hour and the air supply opening has to be the same as the one that will be used afterwards for the test. The weight of the charcoal pieces from the pretest shall be within 20 to 25 % of the fuel charge to be loaded at the start of the test [21]. The test is carried out under natural chimney draught over one big load of wood. The particle emission is measured isokinetically in a dilution tunnel, calculated as an average from four test runs at different wood consumptions and reported as gram emission per kilogram of fuel on dry basis (g/kg). Since 1997 it is required that all stoves installed in Norway have been tested for particle emission according to the Norwegian Standard and fulfil its requirements.

### 6.3.1 The fuel

The standard test fuel (see Figure 6.7) is made of Norwegian spruce pieces with a cross section of 49 mm x 49 mm stitched together with two wood spacers.

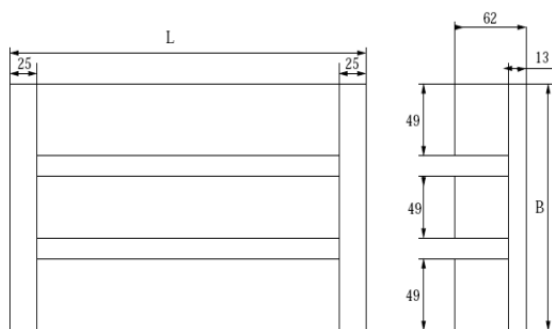

Figure 6.7: Size of the standard test fuel

The moisture content of the test fuel, which is determined with an electrical resistance meter, shall be within the range shown in Table 6.6.

Moisture in spruce (%)	
Wet basis	Dry basis
16 - 20 %	19 - 25 %

Table 6.6: Moisture content of the test fuel [21]

### 6.3.2 The different burn rate categories

The reported particle emission value (g/kg) is calculated as a weighted mean value of the emission results from four test runs (see Equation A.6 in the Appendix), each of which has to belong to one of the burn rate categories shown in Table 6.7 which values are given in kg of consumed wood (dry basis) per hour and are calculated as an average value dividing the weight of the fuel before the test (minus the water content) by the length of the test run. The weighing factors applied in Equation A.6 were obtained from a study of the firing habits in Norway. Therefore, the emission results should represent real use of the appliance within the country.

Burn rate category	1	2	3	4
Grade 1	< 0,80	0,80 - 1,25	1,26-1,90	>1,90
Grade 2	< 1,25	1,25-1,90	1,91-2,80	>2,80

Table 6.7: Burn rate categories according to the Norwegian Standard [21]

The grade of the stove is determined according to its lowest achievable burn rate, i.e. if the stove can not achieve a burn rate lower than 0,80 kg/h it is classified as grade 2. Grade 1 stoves are used for heating of small rooms whereas grade 2 stoves are used for space heating of larger rooms. Jøtul F3 is a Grade 2 stove.

## 6.4 Running a test according to the Norwegian Standard

In this section the procedure for running a test according to the Norwegian Standard will be described. Performing a test involves many tasks. Therefore, it usually takes the whole morning to finish a single test. The whole test run could be divided in four parts: (1) tasks before the pretest, (2) pretest, (3) test and (4) tasks after the test.

Before the pretest can start, several tasks need to be done. First, the standard spruce should be prepared and its moisture recorded. The test fuel width is determined by the spacers. This dimension was constant in our tests, because we have always used spacers of 17 cm. However, the test fuel length was adjusted so that the fuel fulfils the requirement already mentioned in Section 5.1. According to this requirement, the test fuel weight has to lie within 2,1 and 2,6 kg.

The stove must be cleaned from the charcoal and ashes from the previous test. The gas analyzers should be calibrated before each test run. New glass fibre filters are weighed and introduced in their respective filter holders. One of the filter holders is placed in the stack before the pretest and the heating trace is connected and fitted around it so that it has enough time to reach the adequate temperature for the test.

Just before the pretest, the scale is set to zero. The stove is loaded with approx. 2,5 kg of birch. The wood is ignited and the door is left slightly opened for a few minutes to help the ignition process. During the pretest, the air vent opening must be the same as the one that is planned to be used during the test. The pretest ends when the required charcoal bed is achieved and at least one hour has elapsed.

Before loading the test fuel all the pumps for the gas analyzers are turned on and the scale is set to zero again. Furthermore, the labview program must be running and sending data to the excel file. After ranking the charcoal pieces the standard fuel is loaded. The pumps for the particle filters must be turned on immediately after loading the stove. The door was left slightly opened for 5 minutes to help the ignition of the test fuel. The test ends when the scale shows zero, indicating that the total mass of test fuel has been combusted. Right after that, the pumps for the particle filters should be turned off.

After the test, everything is turned off, the filters are weighed and the gas watches reading is noted. Moreover, the silica gel and the filters for the gas dryers must be changed and a leak check should be performed from time to time. Before leaving the laboratory, the stove should be cleaned so that the extraction fan can be turned off.

## 6.5 Running a test according to the EN-13240 Standard

Most of the tests were performed according to the Norwegian Standard. However, in order to compare the emission results, a few tests were performed following the requirements of the EN-13240 regarding test fuel and chimney draft. The procedure for running a test under this conditions is very similar to the one described above. There are only some peculiarities that will be presented next.

The tests must be conducted at nominal heat output (in accordance with EN-13240 section A.4.7). To obtain the required constant draft in the chimney ( $12\pm 2$  Pa) an adjustable damper (see Figure 6.8) was fitted in the top of the stack and a rope was attached to it so that the draft could be regulated from below during the entire test run.



Figure 6.8: Damper used during EN-13240 tests

The tests were performed following the manufacturer instructions to achieve the claimed nominal heat output (see Section 5.4). Instead of performing the test over one big load, the test run is divided into three test periods. During each of this periods a small amount of wood is loaded. The refuelling interval should not be less than 45 minutes. The amount of wood for each test period must be calculated using Equation 4.1 and the technical data of the stove (see Table 5.1). From this calculation, the fuel load for each of the three periods was set to 1,5 kg. The test fuel used during the EN-13240 tests was birch.



# Chapter 7

## Results and Discussion

In this chapter, the results are presented. The discussion will be focused on the Norwegian Standard results. The purpose of the EN-13240 tests was performing some measurements following the standard requirements regarding chimney draft and fuel, to see how these modifications could influence the results. However, it has to be clear that no EN-13240 test was performed as such, since, among other things, our test facility was built according to the Norwegian Standard. Furthermore, due to a problem with the FID, only two of these tests were performed with hydrocarbon measurements. The EN results were calculated as an average of three tests periods.

### 7.1 Fuelsim - Transient

Fuelsim - Transient is a relatively simple, but useful, mass, volume and energy balance spreadsheet mostly used for batch combustion applications. The solid fuel is converted to a fuel gas mixture of O<sub>2</sub>, CO, NO, NO<sub>2</sub>, UHC (unburnt hydrocarbons), SO<sub>2</sub>, N<sub>2</sub>O, H<sub>2</sub>, NH<sub>3</sub>, HCN, Tar, CO<sub>2</sub>, N<sub>2</sub>, Ar and H<sub>2</sub>O [30]. The program was used to calculate the efficiencies and to convert the hydrocarbon content in the wet flue gas (as measured by the FID) to the reported hydrocarbon content in the dry flue gas. Moreover, the reported average emission values of CO, CO<sub>2</sub> and THC (total hydrocarbons) were also obtained with this program.

## 7.2 Emission factors

Emission factors are representative values which attempt to relate the quantity of a pollutant released to the atmosphere with an activity associated with the release of that pollutant [EPA]. In wood combustion, emission factors are expressed as weight of the pollutant divided by energy, volume or weight of the activity emitting the pollutant. Particle emission factors from wood combustion are strongly influenced by the measurement technique. Therefore, data from emission inventories have to be analyzed carefully to consider, not only the emission results, but also the sampling and measurement procedure. In countries with compulsory measurements in the dilution tunnel, emission factors are persistently higher than in those where the measurements are performed directly in the chimney. This is even more remarkable in Norway, where compulsory measurements are also performed at low thermal output with throttled air supply.

In this report, most of the emission results are presented as mg pollutant per megajoule fuel supplied (mg/MJ). The used upper heating value of the wood (MJ end energy contained in the fuel) was 19,122 MJ/kg dry wood for spruce and 18,964 MJ/kg dry wood for birch.

## 7.3 Problems during testing

Obviously, not all the tests were successful. It took a long time to get everything ready and the first tests were performed just to get used to the burning rates, the analyzers, the stove, etc. The main problems found during testing are presented next.

In the beginning, the heating trace used in the stack's filter holder was not working properly. The insulating fabric that covers the resistance was broken and we had to find a new one. Furthermore, the small fan fitted at the end of the dilution tunnel was clogged, not being able to dilute the flue gases properly. It was full of soot and we had to change it. However, a lot of tests were carried out with the fan in this conditions and all of them were refused. Some tests were also rejected because the pretest was not long enough.

The FID was not always available. Moreover, it was difficult to use the appropriate range during the whole test run. Tests 14 and 15 were not considered for this reason.



## 7.4 Appropriate use of the Flame Ionization Analyzer

It is not recommended to use the FID at low burning rates. During poor combustion conditions, the emission of unburnt heavy hydrocarbons increases. These hydrocarbons can condense along the sampling duct forming tar, which could clog the system or originate misleading results. We have used the CO content in the flue gas as an indicator of the combustion quality. High values of CO indicates poor combustion conditions. Therefore, the FID was not used when high values of CO were expected. Since we are interested in using the FID, our project has been focused in the high burning rate range. However, some tests were performed at low air supply to establish the differences between high and low burning rates. These tests were carried out without using the hydrocarbon analyzer.

## 7.5 Combustion conditions

Table 7.1 shows the combustion conditions during each test performed according to the Norwegian Standard. Tests 16 - 19 belong to burn rate category 4 (see Table 6.7). These four tests resulted in burning rates between 2,87 and 4,34 kg dry wood/h. The CO<sub>2</sub> content in the flue gas was 6,64 - 7,56 Vol% and the measured CO was 1427 - 1498 mg/MJ.

Tests 20 - 23 and 31 belong to burn rate category 3. During this group of tests, the burning rate was 2,50 - 2,61 kg dry wood/h, CO<sub>2</sub> was 5,48 - 8,20 Vol% and CO was 1777 - 3555 mg/MJ.

Test 30 belongs to burn rate category 2. In this case, the burning rate was 1,44 kg dry wood/h, CO<sub>2</sub> was 5 Vol% and CO was 9042 mg/MJ wood supplied. Although the resulting average wood consumption was not the intended, tests 30 and 31 were performed at low air supply to study how the results change during poor combustion conditions. Therefore, as explained in the previous section, these tests were performed without the hydrocarbon analyzer. Test 31 will not be used for further analysis because it is the only one that does not fulfil the requirement stated in Section 6.3. The difference between the mean value of the stove surface temperature at the beginning and completion of the test was greater than 70 °C.

Test	Moisture content of the wood (%)	Burning rate (kg dry wood/h)	T inlet chimney (°C)	O <sub>2</sub> in dry flue gas (Vol %)	CO <sub>2</sub> in dry flue gas (Vol%)	CO in dry flue gas (ppm at 11 % O <sub>2</sub> )	Dilution ratio
16	17,5	2,87	390	13,1	7,56	2577	11
17	17,5	3,12	386	14,0	6,76	2598	8
18	18,0	3,28	385	13,5	7,25	2587	8
19	17,5	4,34	386	14,1	6,64	2465	8
20	17,5	2,50	338	14,6	6,13	3630	13
21	20,0	2,61	332	13,8	6,93	3078	11
22	16,3	2,52	363	13,5	7,15	3334	12
23	19,3	2,59	384	12,4	8,20	3395	15
31	16,0	2,50	268	15,2	5,48	6213	18
30	16,0	1,44	231	15,3	5,00	16377	17

Table 7.1: Norwegian Standard - Combustion conditions

Table 7.2 shows the combustion conditions during each test performed following the EN-13240 method. During the EN tests, the burn rate was 0,92 - 1,72 kg dry wood/h, CO<sub>2</sub> was 3,19 - 8,67 Vol% and CO was 643 - 7585 mg/MJ.

Test	Moisture content of the wood (%)	Burning rate (kg dry wood/h)	T inlet chimney (°C)	O <sub>2</sub> in dry flue gas (Vol%)	CO <sub>2</sub> in dry flue gas (Vol%)	CO in dry flue gas (ppm at 11 % O <sub>2</sub> )
35	18,1	1,72	318	12,1	8,67	1091
36	19,0	1,38	286	17,7	3,19	3212
37	16,8	0,92	178	15,2	5,27	13942
38	18,0	1,43	286	13,4	7,30	2830
39	17,3	1,32	288	13,2	7,60	2415
40	18,4	1,52	297	13,6	7,20	1919

Table 7.2: EN Standard - Combustion conditions

## 7.6 Particle emission

Table 7.3 shows the adjusted particle emission results from the Norwegian Standard tests (particle emission measured in the dilution tunnel). These particulate emission values were obtained following the procedure described in NS 3058-2 (see calculations in Appendix A).

During the Norwegian Standard tests 1,4 - 37 grams particulate matter/kg dry wood were measured in the dilution tunnel.

Test	Moisture content of the wood (%)	Burning rate (kg dry wood/h)	Adjusted particle emission $E_{ad}$ (g/h)	Adjusted particle emission $E_{ad}$ (g/kg)	Adjusted particle emission $E_{ad}$ (mg/MJ)
16	17,5	2,87	4,02	1,40	73
17	17,5	3,12	8,73	2,80	146
18	18,0	3,28	10,01	3,05	159
19	17,5	4,34	9,69	2,24	117
20	17,5	2,50	10,54	4,21	220
21	20,0	2,61	5,94	2,28	119
22	16,3	2,52	6,27	2,49	130
23	19,3	2,59	4,13	1,59	83
31	16,0	2,50	24,72	9,88	516
30	16,0	1,44	53,44	37,06	1938

Table 7.3: Norwegian Standard - Adjusted particle emission

The relation between particle emission and burning rate is illustrated in Figure 7.1. The amount of particles emitted into the air usually increases with decreasing average wood consumption [3]. Since most of our tests were carried out at high burning rates, the results do not show this trend clearly. However, it can be noticed that if the burning rate goes below 2 kg/h the particle emission increases rapidly.

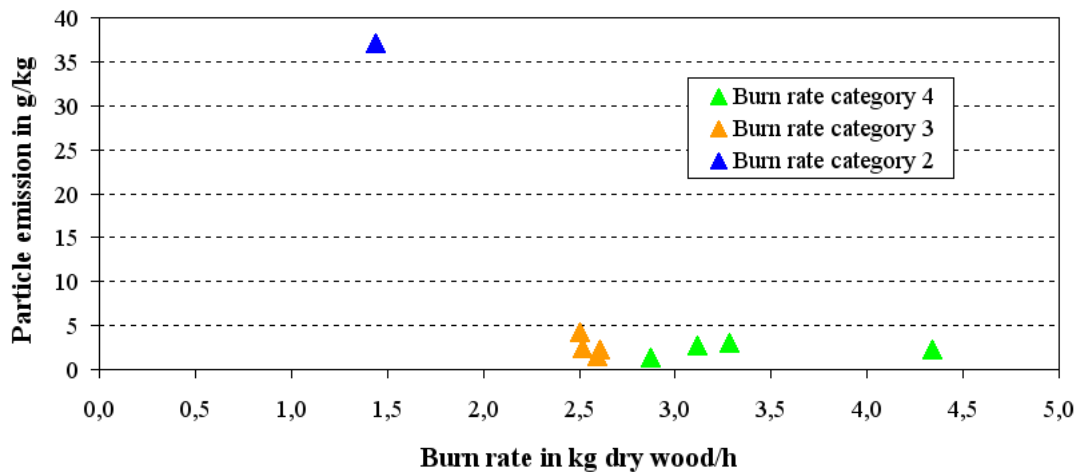

Figure 7.1: Norwegian Standard - Particle emission related to burning rate

During the EN tests, 2 - 43 grams particulate matter/kg dry wood were found in the dilution tunnel. It must be explained that, since the EN Standard does not consider particle emission, these values were also calculated following the Norwegian Standard method. The relation between particle emission and burning rate for the EN tests is illustrated in Figure 7.2. EN-13240 tests must be performed at nominal heat output. However, test 37 was performed at low air supply to prove the increasing particle emission with lower burning rates.

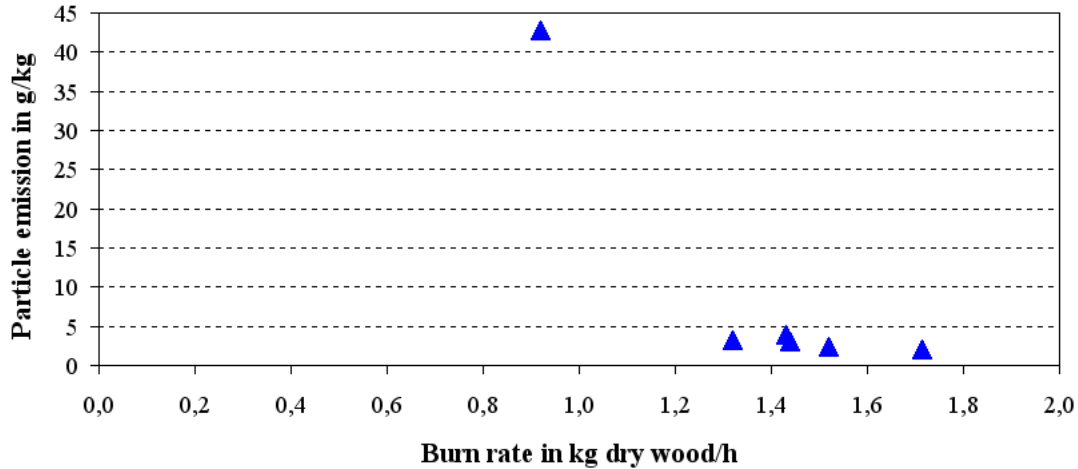

Figure 7.2: EN Standard - Particle emission related to burning rate

The particle emission results were compared with other measurements like for example [17], a certification test according to the Norwegian Standard carried out on the old version of Jøtul F3.

## 7.7 Efficiencies

The average efficiencies were calculated using Fuelsim and are based on the EHV (Effective Heating Value) of the wood. The resulting values from the Norwegian Standard tests are presented in Table 7.4.

Test	Moisture content of the wood (%)	Burning rate (kg dry wood/h)	T inlet chimney (°C)	Thermal efficiency (EHV)	Combustion efficiency (EHV)	Total efficiency (EHV)
16	17,5	2,87	390	0,63	0,97	0,60
17	17,5	3,12	386	0,60	0,96	0,56
18	18,0	3,28	385	0,62	0,96	0,59
19	17,5	4,34	386	0,59	0,97	0,56
20	17,5	2,50	338	0,63	0,95	0,58
21	20,0	2,61	332	0,67	0,96	0,63
22	16,3	2,52	363	0,65	0,96	0,61
23	19,3	2,59	384	0,66	0,97	0,63
31	16,0	2,50	268	0,69	0,95	0,64
30	16,0	1,44	231	0,74	0,89	0,63

Table 7.4: Norwegian Standard - Efficiencies

As demanded by the EN-13240 Standard, the values of CO content in the flue gas, efficiency and heat output are presented in Table 7.5. The selected net heat output from Fuelsim is based on the EHV (Effective Heating Value) of the wood. As it can be noticed, even following the recommendations of the manufacturer, it was difficult to obtain the claimed nominal heat output. However, most of the tests fulfil the EN requirements on CO emission and efficiency (see Section 4.1).

Test	CO in dry flue gas (Vol%)	Total efficiency (EHV)	Heat Output (KW)
35	0,095	0,72	6,0
36	0,096	0,34	2,7
37	0,785	0,69	3,1
38	0,213	0,70	4,8
39	0,178	0,71	4,7
40	0,143	0,69	5,1

Table 7.5: EN Standard - Data according to EN-13240

## 7.8 Comparison between stack and dilution tunnel

Table 7.6 shows the particle emission measured both in the stack and in the dilution tunnel during the Norwegian Standard tests. Furthermore, the Total Hydrocarbon content in the flue gas is also included. As explained before, tests 30 and 31 were carried out without using the FID. Factor F1 corresponds to the ratio between PM measured in the dilution tunnel and PM measured in the stack whereas factor F2 corresponds to the ratio between both PM measured in the stack and hydrocarbon content in the flue gas and PM in the dilution tunnel. Some figures presented afterwards will clarify this relations.

Test	Burning rate (kg dry wood/h)	CO (mg/MJ)	stack filter (mg)	Particles in the stack filter (mg/MJ)	THC (mg/MJ)	DT filter (mg)	Particles in the DT filter (mg/MJ)	F1	F2
16	2,87	1498	4,5	11,8	185,6	4,4	73	6,2	2,7
17	3,12	1498	6,1	19,6	367,2	11,2	146	7,5	2,6
18	3,28	1493	7,8	28,9	345,6	12,3	159	5,5	2,3
19	4,34	1427	4,3	22,1	278,6	8,5	117	5,3	2,6
20	2,50	2068	13,6	20,9	522,7	18,0	220	10	2,5
21	2,61	1777	5,6	17,9	294,8	7,1	119	6,6	2,6
22	2,52	1922	7,0	15,5	306,0	9,1	130	8,4	2,5
23	2,59	1965	4,5	9,7	217,7	5,3	83	8,6	2,7
31	2,50	3555	52,8	75,7		49,5	516	6,8	
30	1,44	9042	258,3	162		220,5	1938	12	

Table 7.6: Norwegian Standard - Comparison between stack and dilution tunnel

During the group of tests belonging to burn rate category 4, 12 - 29 mg particulate matter/MJ was measured in the chimney (flue gas temperature between 385 and 390 °C) and 73 - 159 mg particulate matter/MJ was measured in the dilution tunnel. The hydrocarbon content in the flue gas was between 186 and 367 mg/MJ. During the group of tests belonging to burn rate category 3, measurements resulted in 10 - 76 mg particulate matter/MJ in the chimney (at 268 - 384 °C) and 83 - 516 mg particulate matter/MJ in the dilution tunnel. In this case, the hydrocarbon content in the flue gas was between 218 and 523 mg/MJ. Finally, test 30 gave 162 mg particulate matter/MJ in the chimney (at 231 °C) and 1938 mg particulate matter/MJ in the dilution tunnel. The difference between the particle emission in both measurement points is illustrated in Figure 7.3, were the hydrocarbon content in the flue gas is also included.

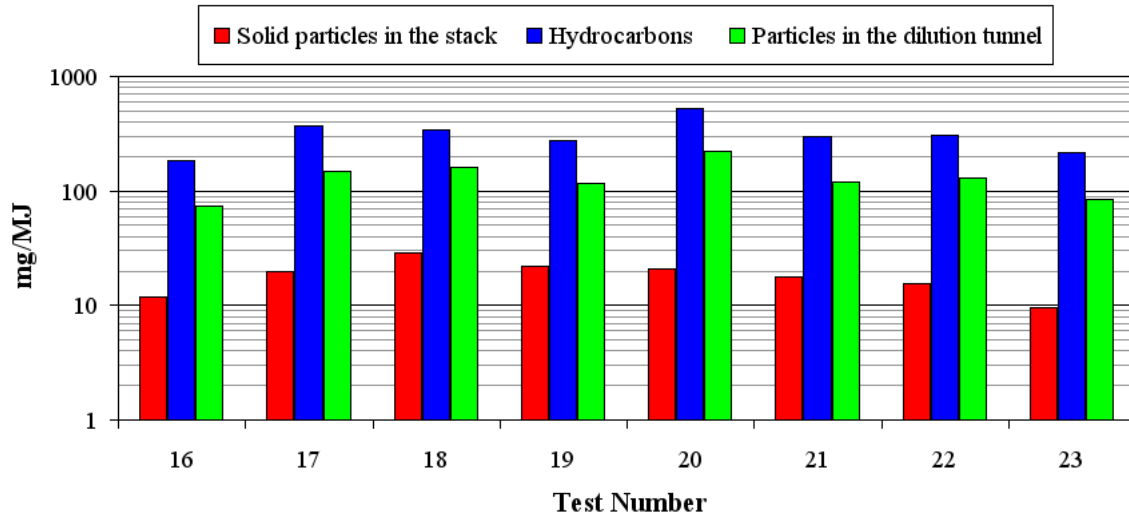

Figure 7.3: Norwegian Standard -  $PM_s$ , Total Hydrocarbon content in the flue gas and  $PM_d$

As shown in Figures 7.4 and 7.5, the particle emission measured in the dilution tunnel was between 5 and 12 times higher than the particle emission measured in the chimney. Since soot is already formed in the flames and should be stable between both sampling points [15], the higher particle emission found in the dilution tunnel is due to the potential contribution of condensed of organic matter.

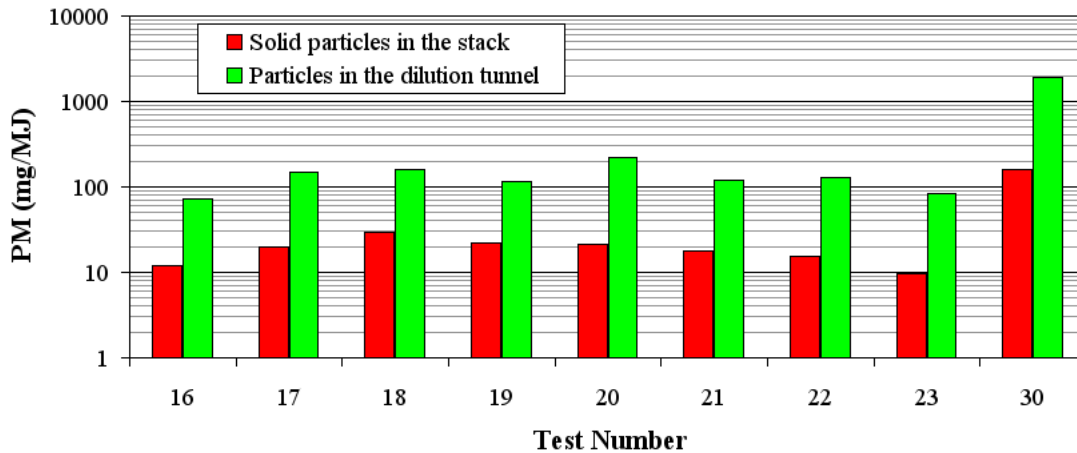

Figure 7.4: Norwegian Standard - Comparison of PM emission in stack and dilution tunnel

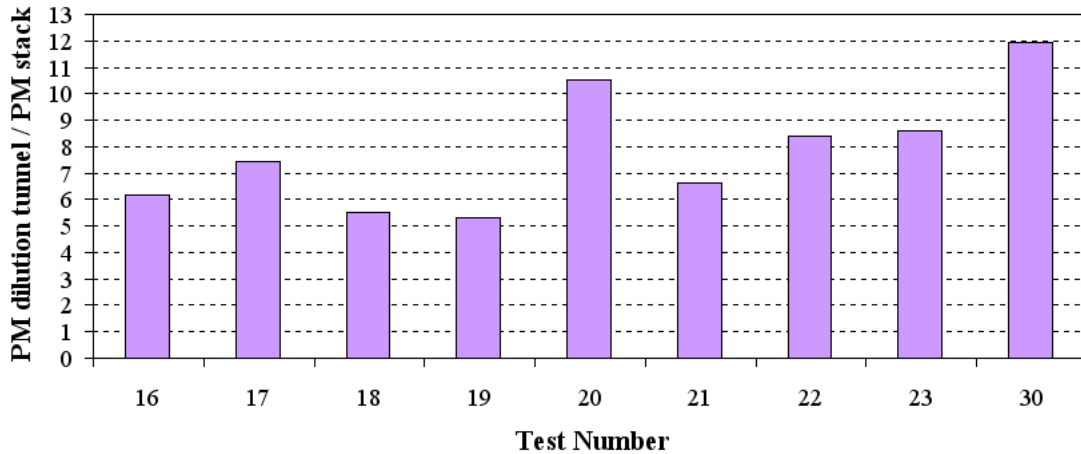

Figure 7.5: Norwegian Standard - Ratio between PM in the dilution tunnel and PM in the stack

The ratio between both particles in the stack and THC measured in the flue gas and particles in the dilution tunnel is illustrated in Figure 7.6. The results show a persistently constant factor of around 2,5 between both measurements, indicating that, obviously, not all the hydrocarbons condense in the dilution tunnel. This is probably due to the difference in type and volatility between the different organic compounds present in the flue gas. This constituents include simple hydrocarbons (C1-C7) which exist as gases or volatilize at ambient conditions and complex heavy substances which condense at ambient temperature.

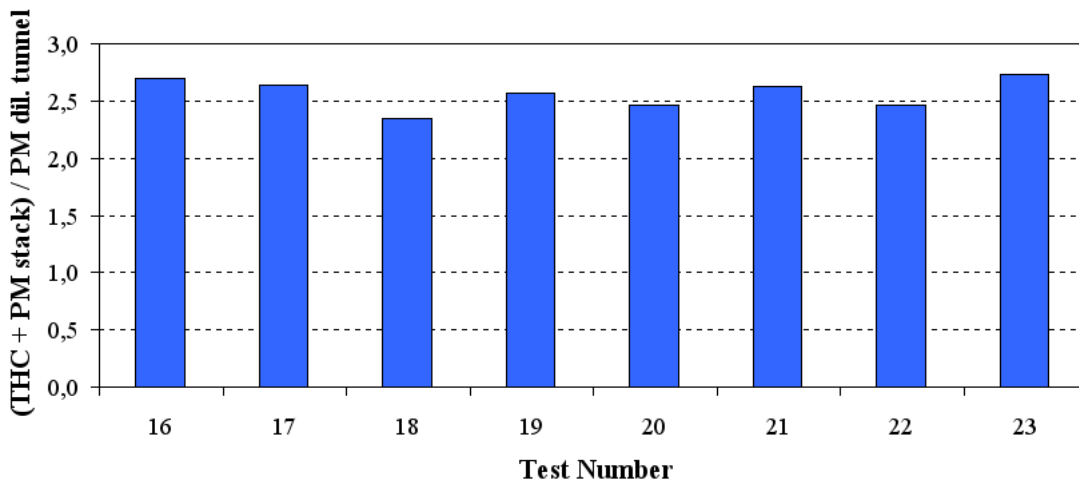

Figure 7.6: Norwegian Standard - Ratio between THC + PM in the stack and PM in the dilution tunnel



Assuming that all the extra particle emission found in the dilution tunnel originates from condensed organic matter, the results show that about 35 % of the hydrocarbons measured in the stack with the Flame Ionization Detector condense along the dilution tunnel forming liquid particles that are subsequently measured as particle emission. Furthermore, the results also reveal that these condensed tar compounds account for approximately 85 % of the total particle emission found at this location. These percentages are illustrated in Figures 7.7 and 7.8.

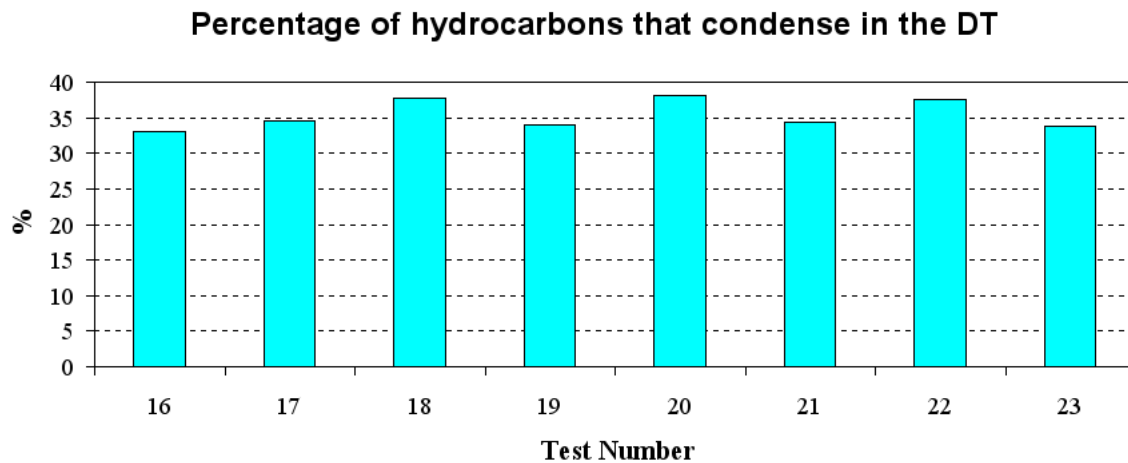

Figure 7.7: Norwegian Standard - Percentage of hydrocarbons measured with the FID found as particles in the dilution tunnel

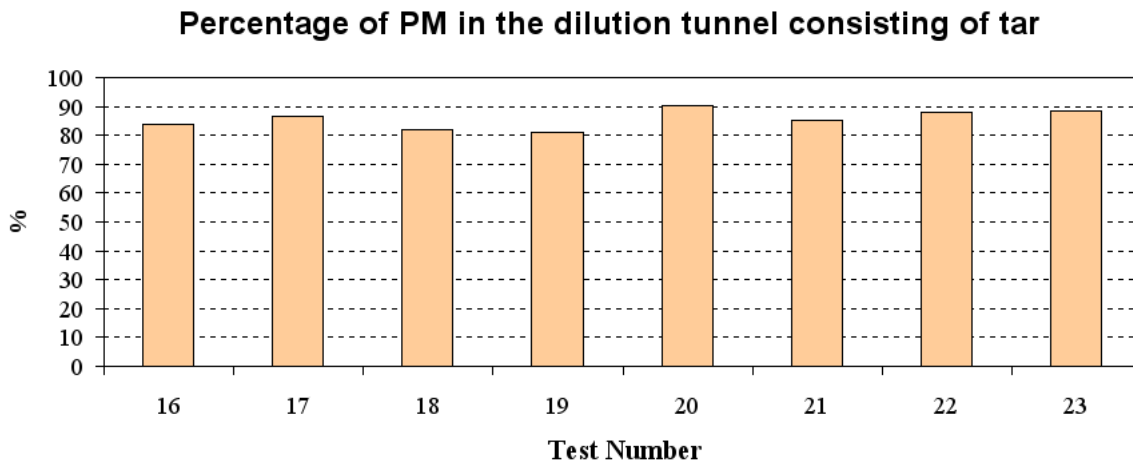

Figure 7.8: Norwegian Standard - Percentage of total PM measured in the dilution tunnel consisting of condensed organic matter

Figure 7.9 illustrates the influence of the combustion quality on the ratio  $PM_{\text{dilution tunnel}} / PM_{\text{stack}}$ . The results show a general trend of increasing difference between both measurements with increasing CO content in the flue gas. This is due to the higher emission of unburnt hydrocarbons from incomplete combustion during poor combustion conditions.

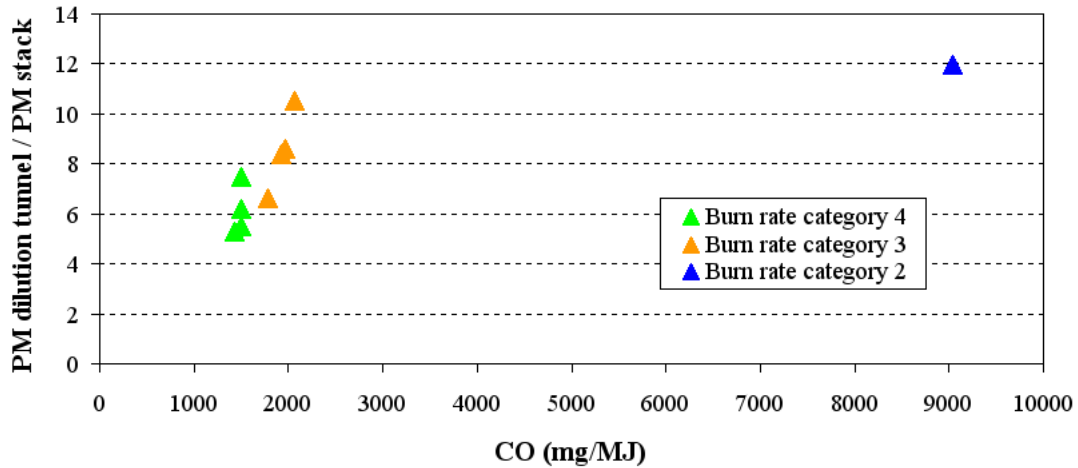

Figure 7.9: Norwegian Standard - Ratio  $PM_d/PM_s$  related to combustion conditions

The presented results are consistent with other studies. In [15], parallel measurements of particle emission in the chimney according to the Swedish method and in a dilution tunnel according to the Norwegian method were performed during the combustion of wood logs in a stove. Different combustion conditions were achieved by firing wood at different burn rates. Four tests belong to burn rate category 2 of the Norwegian Standard and another four to burn rate category 3 (see Table 6.7). The test fuel used was the same standard spruce used during our tests. In this study, the particle emission measured in the dilution tunnel was between 2 and 10 times higher than the particle emission value measured in the chimney. The corresponding CO emission was 4100 - 7600 mg/MJ. The report also reveals the larger difference between both measurement methods during poor combustion conditions.

Another study performed in Switzerland following the CEN proposed method for particle emission measurements parallel to EN-13240 type testing (see Section 4.4), also shows a similar trend. The stove used for this study was also a Jøtul F3. The results showed that particle emissions measured in the dilution tunnel were between 40% and 160% higher than if they were sampled directly from the stack using a heated filter [16]. The study also points to a relation between this ratio and the combustion efficiency.

A survey on measurements and emission factors from biomass combustion carried out by the International Energy Agency (IEA) also deals with this topic. The survey gathers emission

data from several countries. For wood stoves, all measurements performed with throttled air supply resulted in a factor of 2,5 - 10 between particle emission measured in the dilution tunnel and particle emission measured directly in the hot flue gases [4].

The comparison between stack and dilution tunnel for the EN tests is presented next. During these tests, 11 - 194 mg particulate matter/MJ was measured in the chimney (flue gas temperature between 178 and 318 °C) and 108 - 2252 mg particulate matter/MJ was measured in the dilution tunnel. The results are shown in Table 7.7.

Test	Burning rate (kg dry wood/h)	CO (mg/MJ)	stack filter (mg)	Particles in the stack filter (mg/MJ)	THC (mg/MJ)	DT filter (mg)	Particles in the DT filter (mg/MJ)	F1	F2
35	1,72	643	27,9	10,9	48,9	12,8	108	9,9	0,5
36	1,38	1730	33,4	18,9	743,2	19,1	157	8,3	4,8
37	0,92	7585	351,9	194,2		438,5	2252	11,6	
38	1,43	1648	33,4	14,95		26,4	211	14,1	
39	1,32	1405	28,3	16,43		20,9	170	10,4	
40	1,52	1121	25,3	13,28		14,32	123	9,3	

Table 7.7: EN Standard - Comparison between stack and dilution tunnel

As shown in Figures 7.10 and 7.11, the EN results also corroborate the higher particle emission found when measurements are performed after cooling and diluting the flue gas. The particle emission measured in the dilution tunnel was between 8 and 14 times higher than the particle emission measured in the chimney.

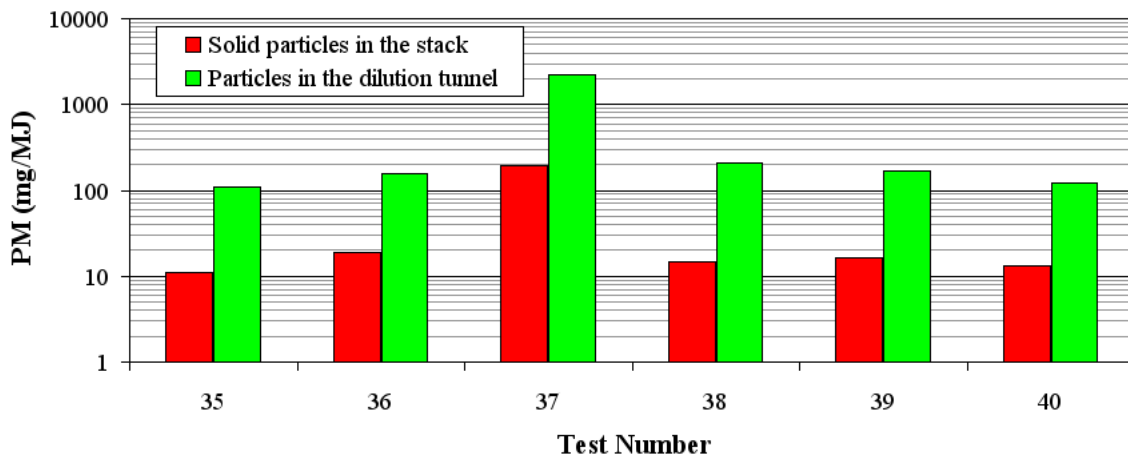

Figure 7.10: EN Standard - Comparison of PM emission in stack and dilution tunnel

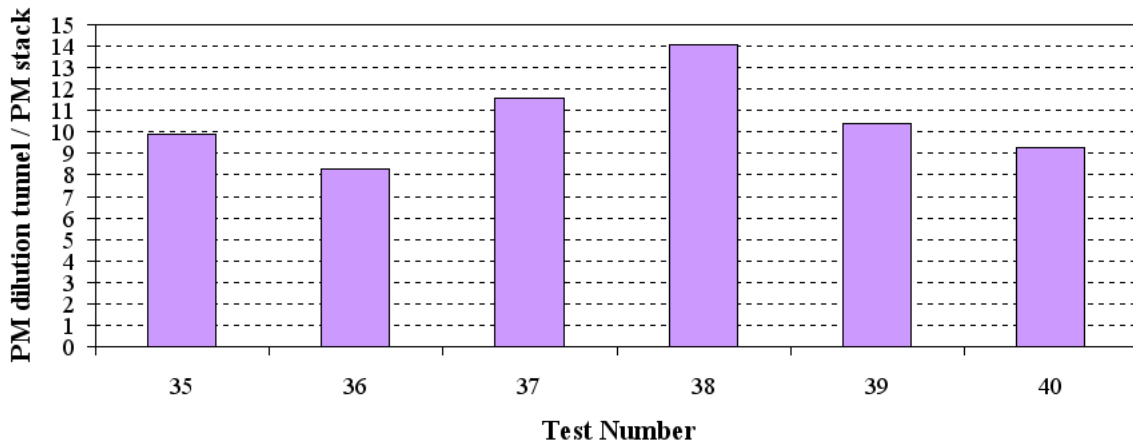

Figure 7.11: EN Standard - Ratio between PM in the dilution tunnel and PM in the stack

Unfortunately, due to a problem with the FID, not enough EN tests were carried out including hydrocarbon measurements. Therefore, it is not possible to establish any further conclusions in this sense. As shown in Table 7.7, only two tests were performed with the FID, leading to contradictory results. Especially during test 35, some mistake must have been made when measuring the hydrocarbon content, either with the range of the FID or during the conversion with Fuelsim. However, the results were carefully reviewed and no error was found.

[18] was used as guidance during the EN tests. In this report, measurements of the total hydrocarbon content in the flue gas were performed on a Jøtul F3 parallel to an EN-13240 type test. The test results are also based on a mean value of the three test periods. The mean value of the THC (Total Hydrocarbon Content) in the flue gas was 172 ppm (as methane equivalent) and the CO content 0,113 (% at 13 % O<sub>2</sub>). The efficiency during the test was 68% and the heat output 5,8 kW.

The typical look of the filters after performing the tests is shown in Figure 7.12. In the stack filter most of the particles consist of soot, with its characteristic black color. In contrast, the brown color found in the dilution tunnel is due to the organic compounds, which condense forming tar.

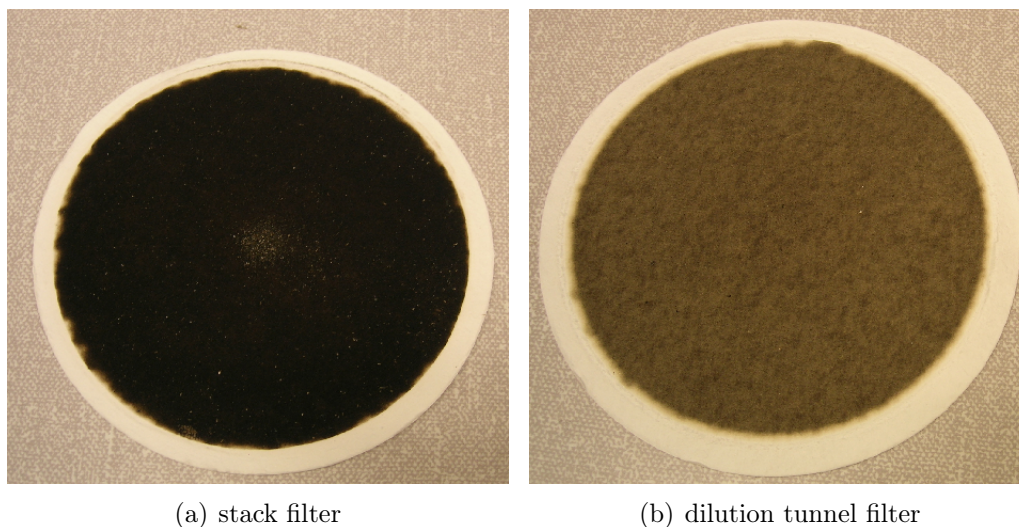

Figure 7.12: Typical look of the filters after performing the tests

## 7.9 Accuracy and Reliability

The accuracy of the measuring equipment is presented in the previous chapter. Several factors like moisture, ignition or colocation of the fuel in the stove influence greatly the emission results. Considering the influence that these factors have in the combustion process, the obtained results from the Norwegian Standard tests appear to be rather constant. Being similar to the ones presented in other studies, the results are found to be quite reliable.



# Chapter 8

## Conclusions

The difference between measuring particle emission directly in the stack and in a dilution tunnel has been analyzed. For the Norwegian Standard tests, the particle emission measured in the dilution tunnel was between 5 and 12 times higher than in the chimney. For the EN tests, this factor was between 8 and 14. The more unfavourable combustion conditions, the larger the difference between both measurements was seen. The higher particle emission found in the dilution tunnel is due to condensed organic compounds. Therefore, particle emission inventories including only solid particles may underestimate the real contribution of wood combustion to atmospheric particulate matter.

The Norwegian Standard results also show a factor of about 2,5 between both particle emission measured in the stack and Total Hydrocarbon content in the flue gas and particle emission measured in the dilution tunnel, indicating that about 35 % of the hydrocarbons measured in the stack with the Flame Ionization Detector condense along the dilution tunnel accounting for approximately 85 % of the total particle emission found at this location.

The obtained factors may be useful to compare different measurements and to roughly predict what would be, for example, the particle emission measured in the dilution tunnel if emission data on particle emission measured in the stack is available.

From this work, it can be concluded that the best way to measure particle emission from wood combustion is by using a dilution tunnel, thus cooling the flue gases, thus allowing condensation of organic compounds. This method mimics what truly happens when the flue gases reach the atmosphere. However, measuring only solid particles directly in the stack is cheaper and faster and still provides useful information about the environmental performance of an appliance.

Since condensables from wood combustion have been identified as highly toxic [4], a separate measurement of condensables and solid particles could also be interesting. Furthermore, measuring at several average wood consumptions will provide more realistic emission results than measuring only at one average wood consumption.

Further research is necessary to investigate the influence of certain important combustion parameters on the obtained results. New measurements could be carried out with different fuel, different moisture content, shorter ignition period, etc.



# Bibliography

- [1] Øyvind Skreiberg. *Theoretical and experimental studies on emissions from wood combustion*. PHD thesis, The Norwegian University of Science and Technology, Trondheim, Norway. Faculty of Mechanical Engineering, Department of Thermal Energy and Hydropower, 1997.
- [2] Thomas Nussbaumer. *Wood combustion*. In *Advances in Thermochemical Biomass Conversion*, Pages 575-589, 1994.
- [3] Edvard Karlsvik, Johan E. Hustad and Otto K. Sønju. *Emissions from wood stoves and fireplaces*. In *Advances in Thermochemical Biomass Conversion*, Pages 690-707, 1994.
- [4] Thomas Nussbaumer, Claudia Czasch, Norbert Klippel, Linda Johansson and Claes Tullin. *Particulate Emissions from Biomass Combustion in IEA Countries, Survey on Measurements and Emission Factors*, January 2008.
- [5] Gunnar Barrefors and Göran Petersson, *Volatile hydrocarbons from domestic wood burning*. In *Chemosphere*, Vol. 30, No. 8, pp. 1551-1556, 1995.
- [6] C.K.W. Ndiema, F.M. Mpendazoe and A. Williams. *Emission of pollutants from a biomass stove*. In *Energy Conversion and Management*, Vol. 39, No. 13, pp. 1357-1367, 1998.
- [7] International Energy Agency. *The Handbook of Biomass Combustion & Co-firing*, 2002.
- [8] Danish Environmental Protection Agency. *Comparison of measuring results between solid fuel stoves tested in accordance with EN-13240 and NS-3058*, December 2006.
- [9] International Energy Agency, Task X, Combustion. *Round Robin Test of a Wood Stove – Emissions*, February 1995.
- [10] Marquita K. Hill. *Understanding Environmental Pollution, Chapter 5: Air Pollution*, January 2004.

- 
- [11] Nordic Ecolabelling. *Swan labelling of Closed Fireplaces, Version 2.0*, March 2006.
- [12] Edvard Karlsvik. *Comparison of Test Standards from Various Countries*.
- [13] Aerosols from Biomass Combustion, International Seminar in Zurich, June 2001.
- [14] T. Nussbaumer and J. E. Hustad. *Overview of Biomass Combustion*, October 1996.
- [15] Linda Johansson, Lennart Gustavsson, Claes Tullin, Daniel Ryde and Marie Rönnbäck, SP Technical Research Institute Sweden. *Comparison of particle sampling in chimney and dilution tunnel during residential combustion of wood logs*.
- [16] Christian Gaegauf and Timothy Griffin, University of Applied Science Bale/Muttenz. *Comparison of in-stack and dilution tunnel measurement of particulate emission*, April 2007.
- [17] SINTEF Energi - Norges branntekniske laboratorium, Jøtul 3 R Prøvningsrapport, October 1997.
- [18] Stefan Österberg, Energy Technology, SP Swedish National Testing and Research Institute. *Testing a residential roomheater fired by wood, Jøtul F3 Report*, April 2005.
- [19] European Committee for Standardization. *Up-to-date draft of EN TS on particulate emission test method*, January 2007.
- [20] European Standard EN 13240: Roomheaters fired by solid fuel, Requirements and test methods, April 2001.
- [21] Norwegian Standard NS 3058-1: Enclosed wood heaters smoke emission, part 1: Test facility and heating pattern, June 1994.
- [22] Norwegian Standard 3058-2: Enclosed wood heaters smoke emission, part 2: Determination of particle emission, June 1994.
- [23] Norwegian Standard NS 3059: Enclosed wood heaters smoke emission – requirements, October 1994.
- [24] VDI 1066 - Sheet 2: Measurement of particulate matter; manual dust measurement in flow gases; gravimetric determination of dust load.
- [25] Environmental Protection Agency (EPA), *Method 5G: Determination of particulate matter emissions from wood heaters (dilution tunnel sampling location)*, February 2000.

- 
- [26] Environmental Protection Agency (EPA), *Method 28: Certification and auditing of wood heaters*, February 2000.
- [27] British Standard document PD 6434: Recommendations for the design and the testing of smoke reducing solid fuel burning domestic appliances.
- [28] Jøtul AS, Jøtul F3 Installation Instructions with Technical Data and General Use and Maintenance Manual (English Version).
- [29] Jøtul AS web page, *www.jotul.com*.
- [30] Øyvind Skreiberg. *Fuelsim - Transient v1.0*, The Norwegian University of Science and Technology, Institute of Thermal Energy and Hydropower, August 2002.



# Appendix A

## Calculations

The following calculations shall be used to calculate the particulate emission rate according to the Norwegian Standard:

### A.1 Gas meter volume

$$V_{m(norm)} = \frac{V_m \times Y \times T_{norm} \times P_{bar}}{T_m \times P_{norm}} = \frac{K_I \times V_m \times Y \times P_{bar}}{T_m} \quad (A.1)$$

Where:

$V_{m(norm)}$  is the gas volume from the sample measured by dry gas meter or similar measuring equipment and correlated to standard conditions, in  $\text{dm}^3$  (273 K and 760 mm Hg).

$V_m$  is volume of gas sample measured by dry gas meter or similar measuring equipment, in  $\text{dm}^3$ .

$Y$  is the gas meter or similar measuring equipment calibration factor.

$T_{norm}$  is 273 K.

$P_{bar}$  is air pressure at the sampling site, in mm Hg.

$T_m$  is average dry gas meter temperature during the measuring period, in K.

$P_{norm}$  is 760 mm Hg.

$K_I$  is 0,3858 K/mm Hg.

## A.2 Particulate concentration

$$C_s = \frac{m_n}{1000 \times V_{m(norm)}} \quad (\text{A.2})$$

Where:

$C_s$  is the concentration of particulate matter in the flue gas on dry basis, correlated to standard conditions, in g/dm<sup>3</sup> (273 K and 760 mm Hg).

$m_n$  is the total amount of particulate matter collected, in mg.

$V_{m(norm)}$  is the gas volume from the sample measured by dry gas meter or similar measuring equipment and correlated to standard conditions, in dm<sup>3</sup> (273 K and 760 mm Hg).

## A.3 Particulate emission rate

$$E = C_s \times Q_{ad} \quad (\text{A.3})$$

Where:

$E$  is the particulate emission rate, in g/h.

$Q_{ad}$  is the average gas flow rate in the dilution tunnel, in dm<sup>3</sup>/h (273 K and 760 mm Hg).

$C_s$  is the concentration of particulate matter in the flue gas on dry basis, correlated to standard conditions, in g/dm<sup>3</sup> (273 K and 760 mm Hg).

## A.4 Adjusted particulate emission rate

Particulate emission results shall be adjusted for reporting purposes using Equation A.4:

$$E_{ad} = 1,82 \times E^{0,83} \quad (\text{A.4})$$

Where:

$E_{ad}$  is the particulate emission rate adjusted to reported emission, in g/h.

$E$  is the particulate emission rate, in g/h.

To obtain the particulate emission rate in g/kg dry wood for an individual test:

$$E_{ad}(g/kg) = \frac{E_{ad}}{b} \quad (\text{A.5})$$

$E_{ad}(g/kg)$  is the particulate emission rate adjusted to reported emission, in g/kg dry wood.

$E_{ad}$  is the particulate emission rate adjusted to reported emission, in g/h.

$b$  is the burn rate of the test, in kg dry wood/h.

## A.5 Particulate Emission Requirements

The particle emission requirements in Norway are shown in Table A.1.

	Maximum for each test	Maximum weighted mean value
Stove with catalyst	10 g/kg	5 g/kg
Stove without catalyst	20 g/kg	10 g/kg

Table A.1: Particulate emission requirements in Norway [23]

## A.6 Calculation of weighted particulate emission

$$E_V = \frac{\sum_{i=1}^n \left( K_i \cdot \frac{E_{(ad)_i}}{m_i} \right)}{\sum_{i=1}^n K_i} \quad (\text{A.6})$$

$E_V$  is the weighted particulate emission from the tests in g/kg dry wood.

- 
- $n$  is the total number of tests.
- $P_i$  is the probability for burn rate category for test  $i$ .
- $K_i$  is the weighted factor of the test which is  $P_{i+1} - P_{i-1}$ .
- $E_{(ad)_i}$  is the weighted particulate emission in g/h from the test  $i$ .
- $m_i$  is the mean burn rate on dry basis in kg/h for test  $i$ .



# Appendix B

## Norwegian Standard Graphs

The subtitles of the following graphs correspond to:

- (a) Fuel burnt against time
- (b) Surface temperatures of the stove against time
- (c) CO<sub>2</sub> and O<sub>2</sub> content in the dry flue gas in Vol% and excess air ratio against percentage of dry fuel burnt
- (d) Total hydrocarbon content in the dry flue gas in ppm and CO content in the dry flue gas in Vol% against percentage of dry fuel burnt<sup>1</sup>
- (e) Combustion, Thermal and Total Efficiencies against percentage of dry fuel burnt
- (f) Combustion chamber and chimney inlet temperatures against percentage of dry fuel burnt
- (g) Stack and dilution tunnel filter temperatures against percentage of dry fuel burnt
- (h) Pitot and chimney negative pressures against percentage of dry fuel burnt

---

<sup>1</sup>Tests 30 and 31 were performed at low air supply. Since it is not recommended to use the FID in this circumstances, the graphs only illustrate the CO content.



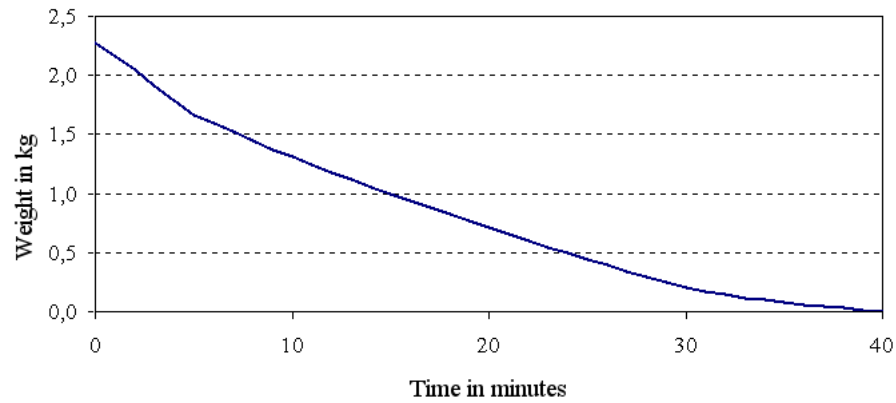

(a)

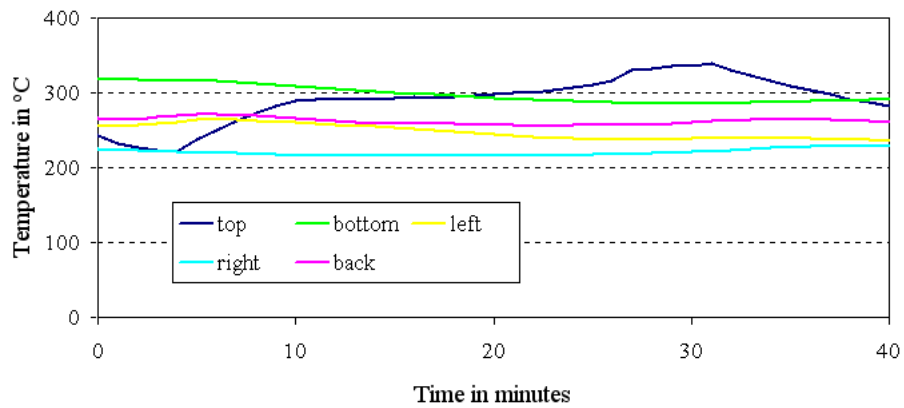

(b)

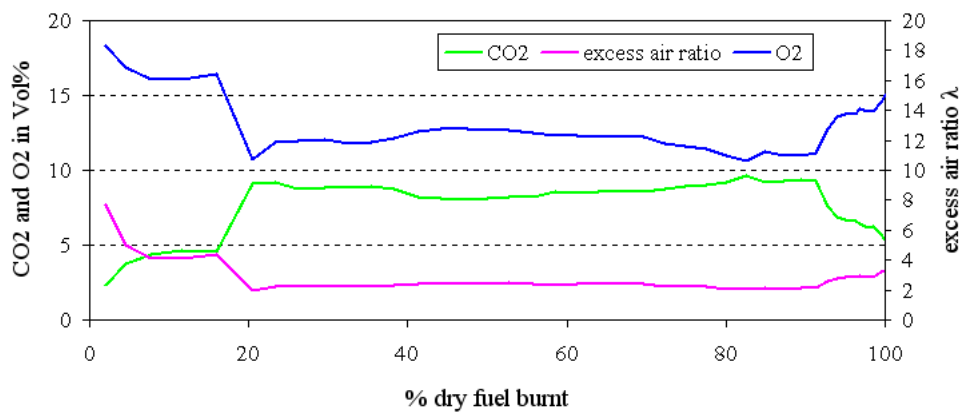

(c)

Figure B.1: Test 16 - Graphs (a)-(c)

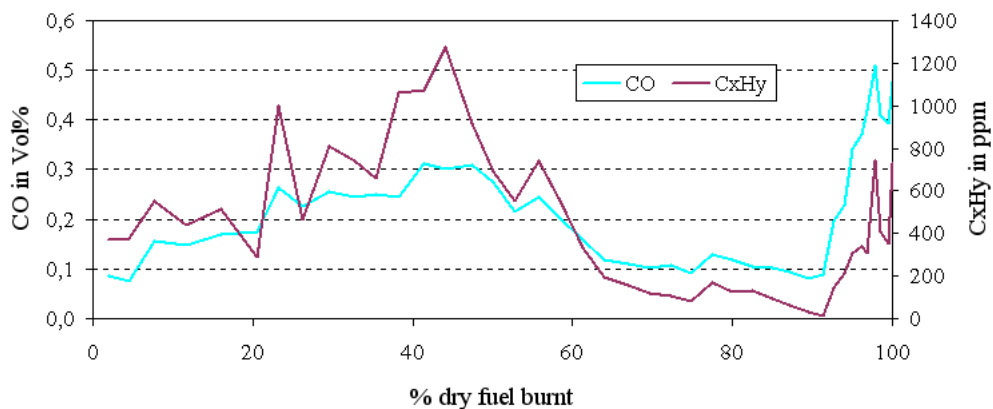

(d)

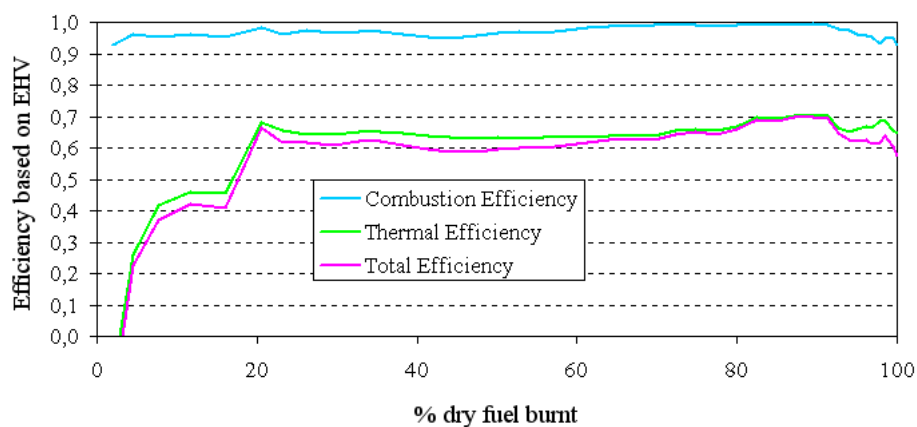

(e)

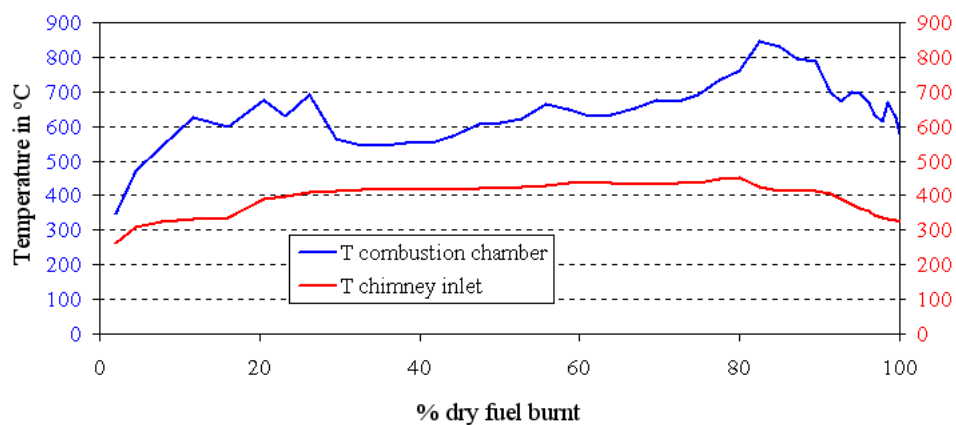

(f)

Figure B.2: Test 16 - Graphs (d)-(f)

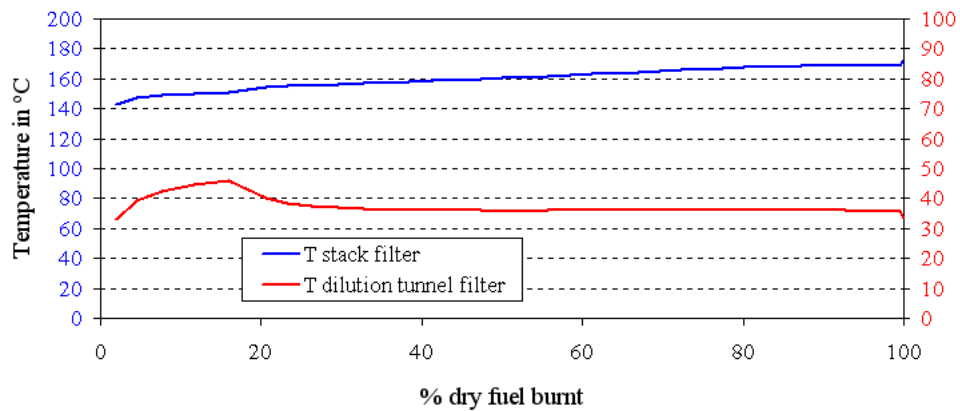

(g)

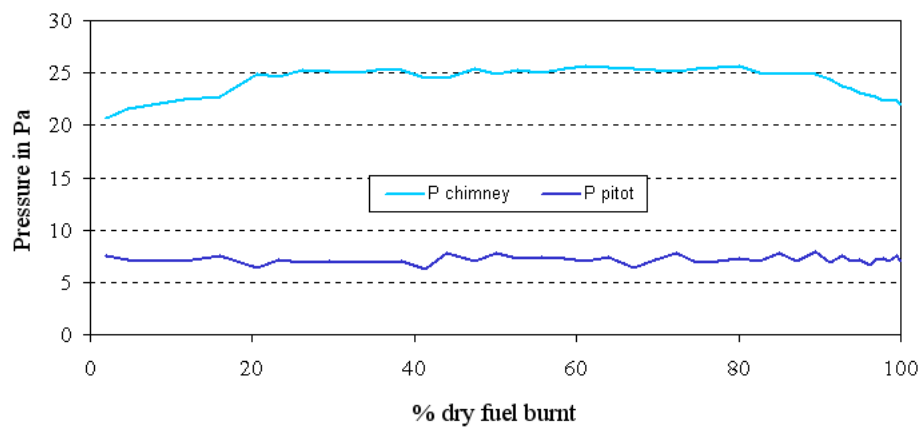

(h)

Figure B.3: Test 16 - Graphs (g)-(h)

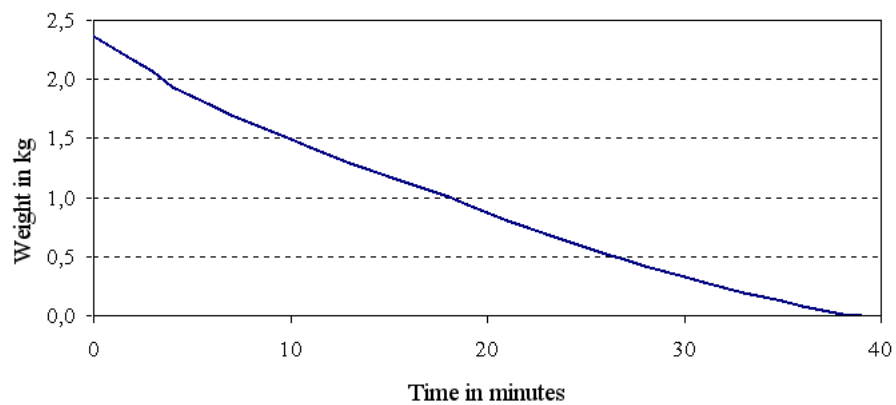

(a)

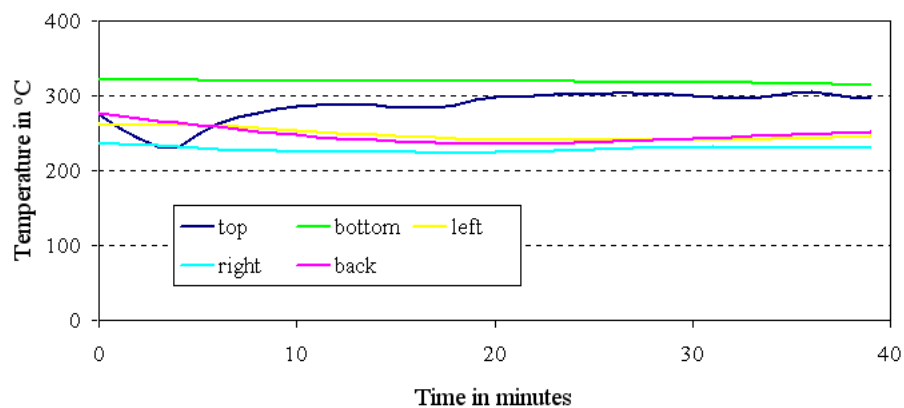

(b)

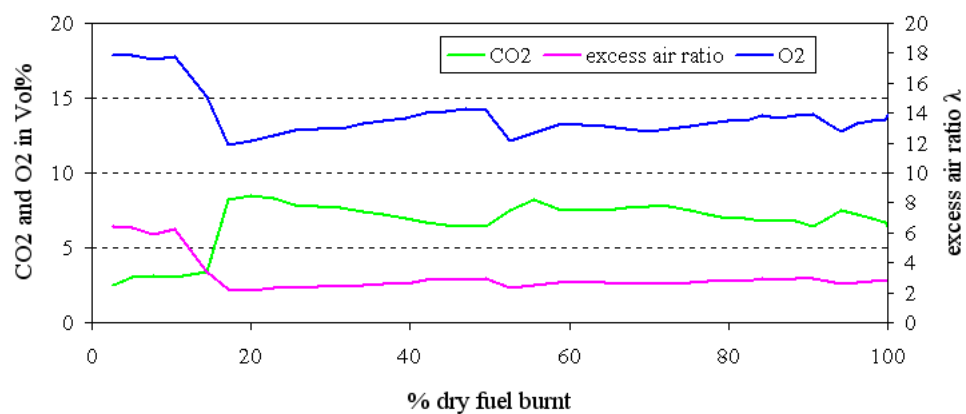

(c)

Figure B.4: Test 17 - Graphs (a)-(c)

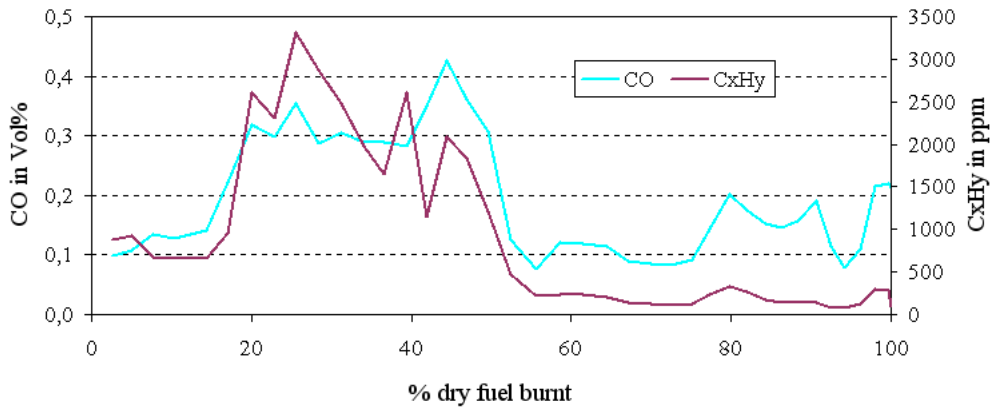

(d)

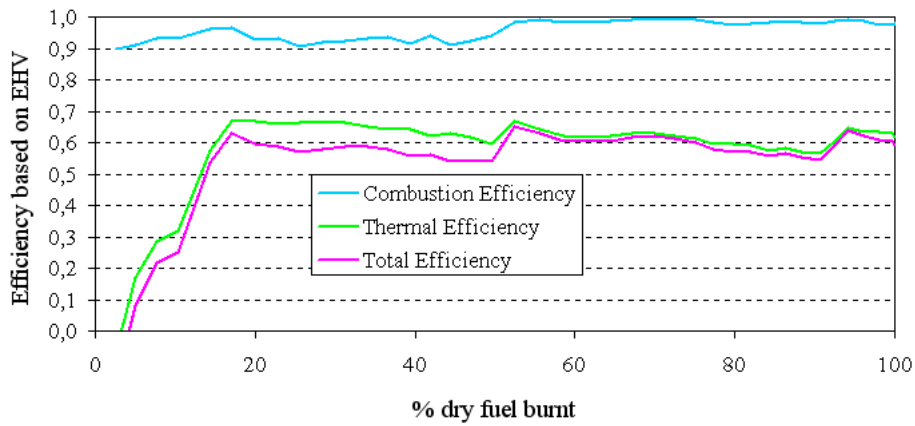

(e)

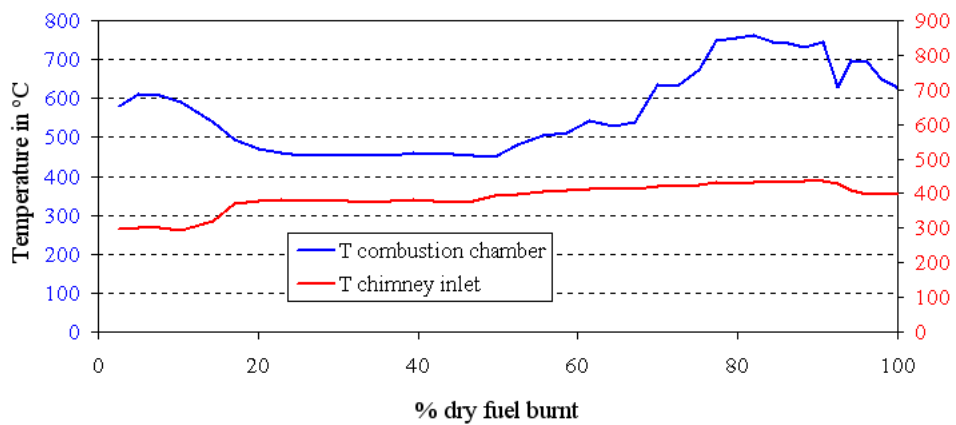

(f)

Figure B.5: Test 17 - Graphs (d)-(f)

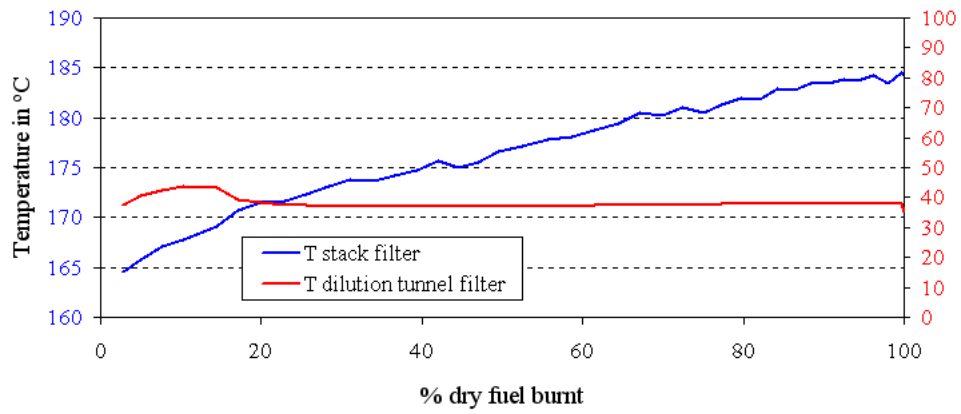

(g)

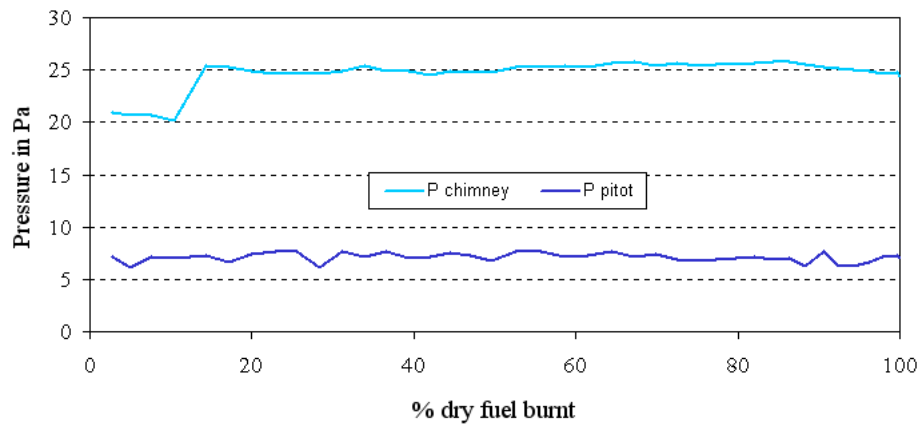

(h)

Figure B.6: Test 17 - Graphs (g)-(h)



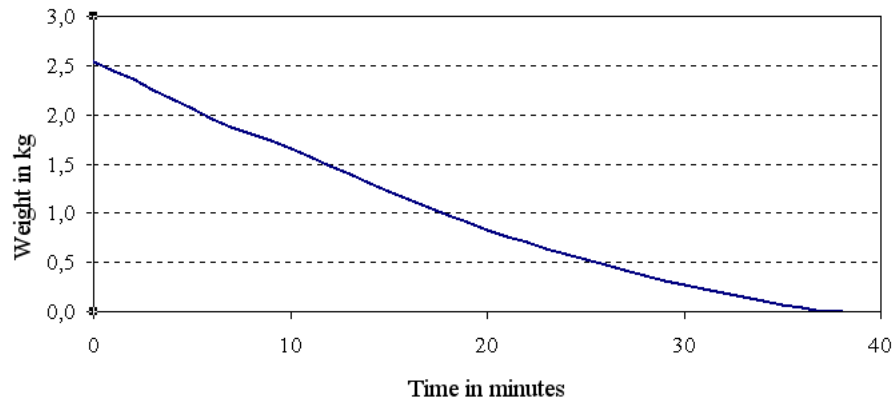

(a)

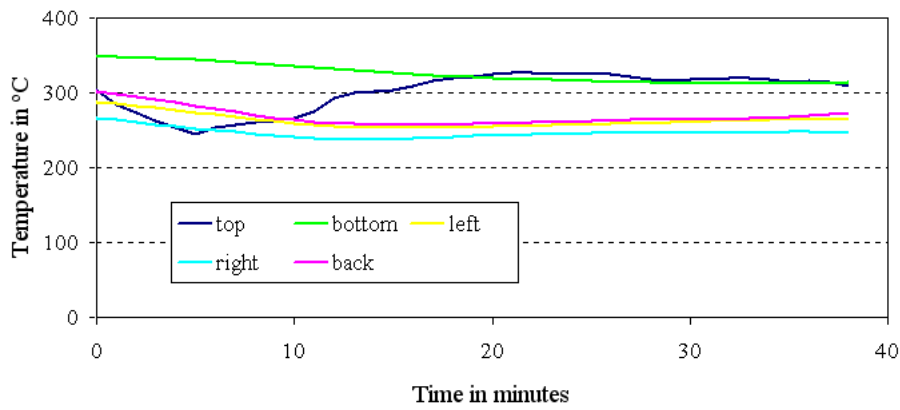

(b)

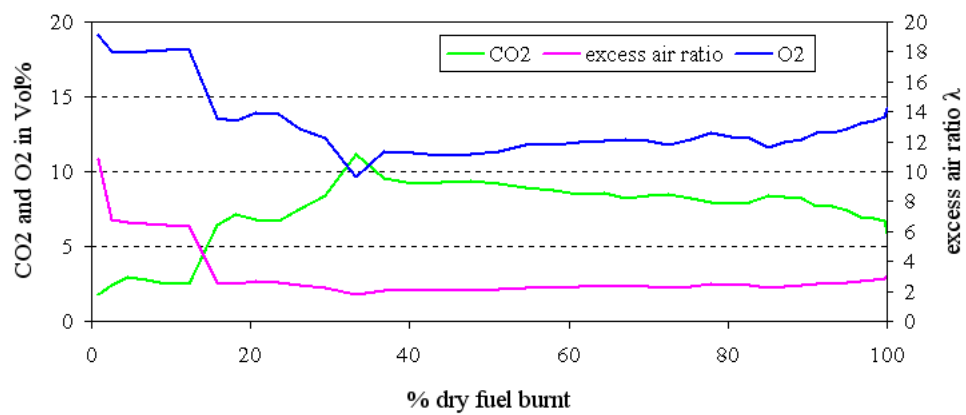

(c)

Figure B.7: Test 18 - Graphs (a)-(c)

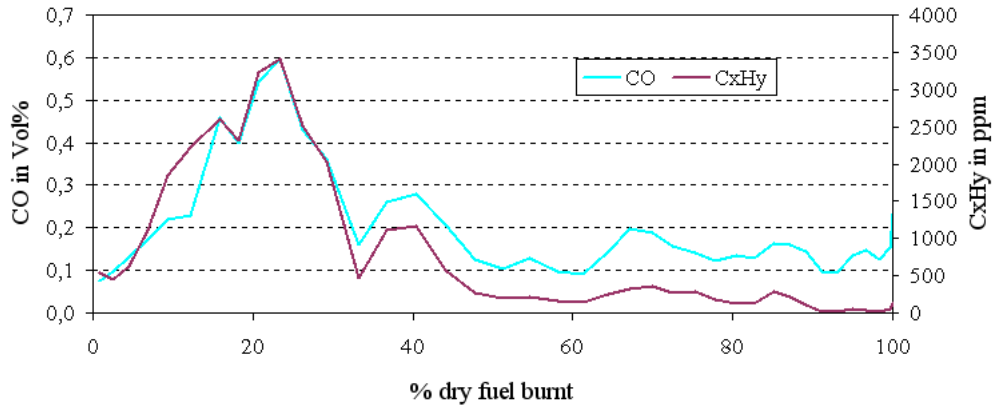

(d)

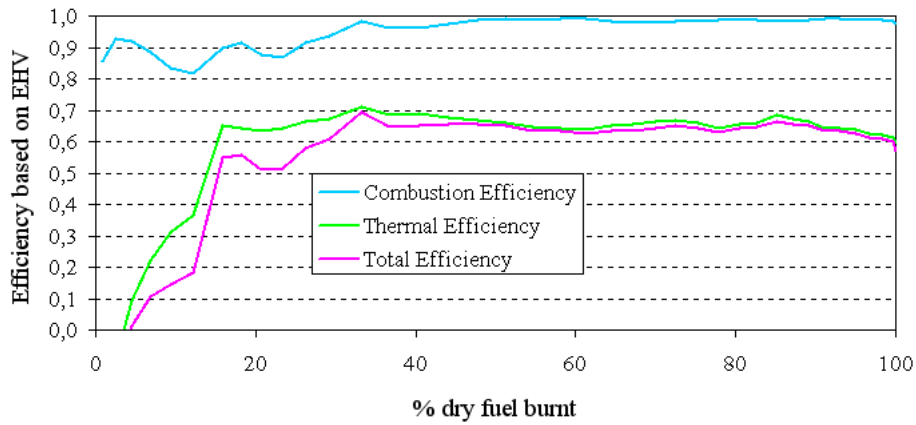

(e)

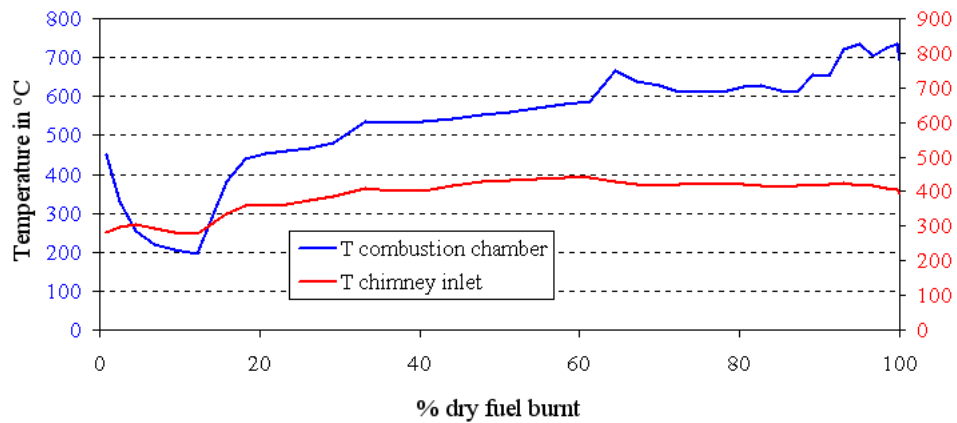

(f)

Figure B.8: Test 18 - Graphs (d)-(f)

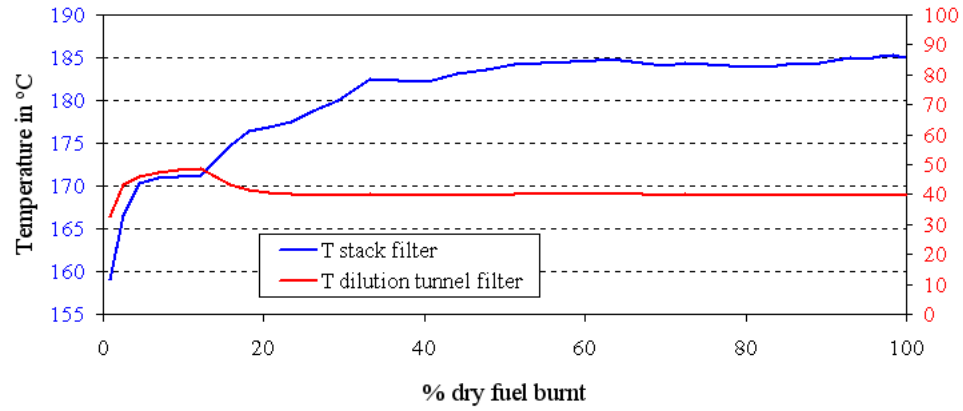

(g)

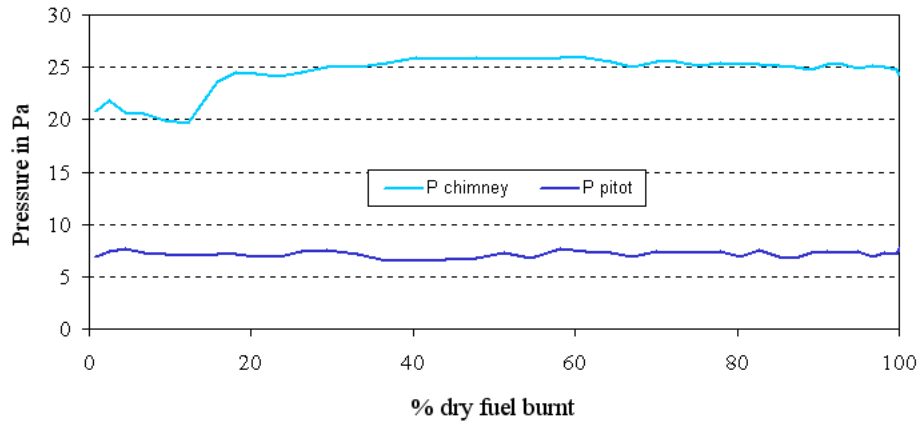

(h)

Figure B.9: Test 18 - Graphs (g)-(h)

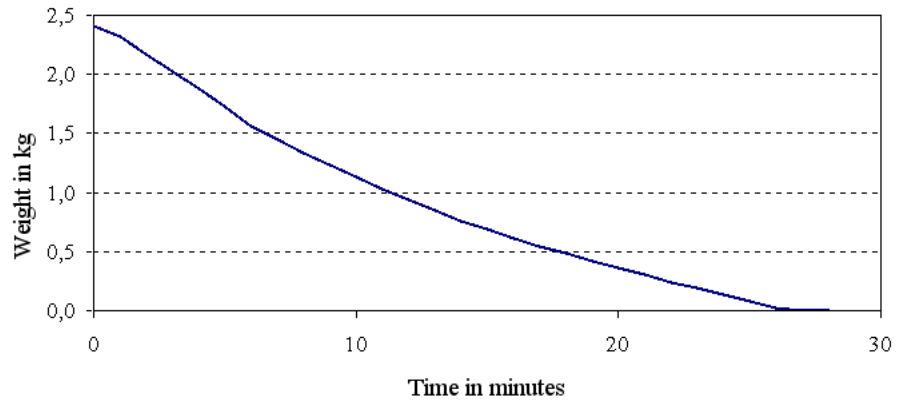

(a)

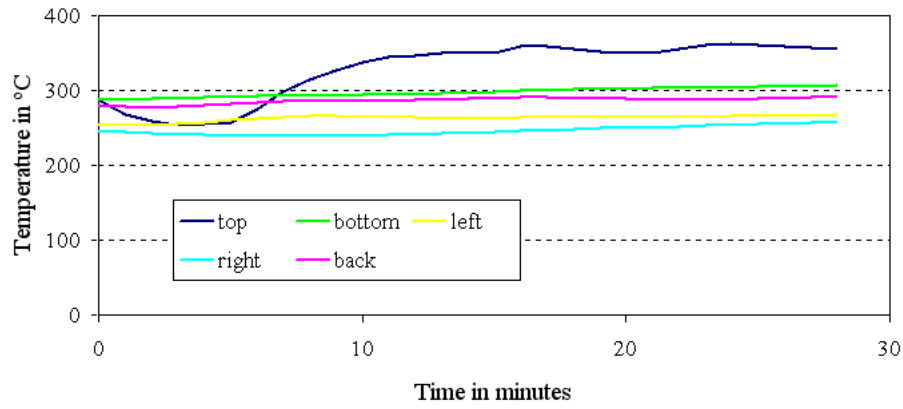

(b)

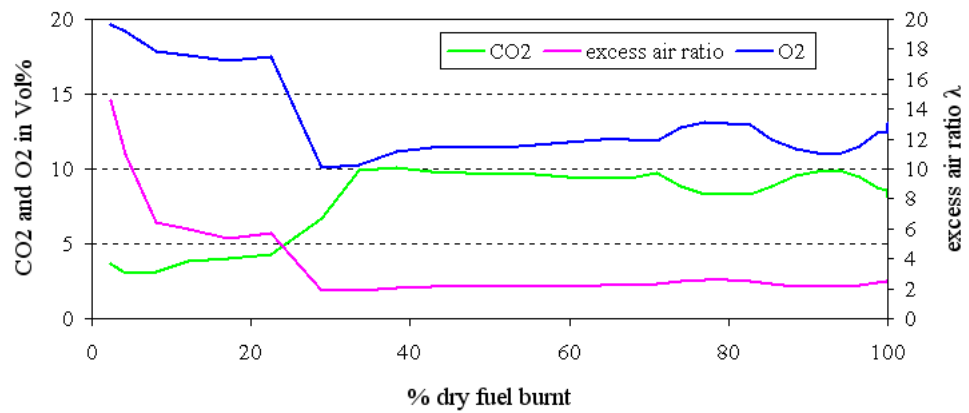

(c)

Figure B.10: Test 19 - Graphs (a)-(c)

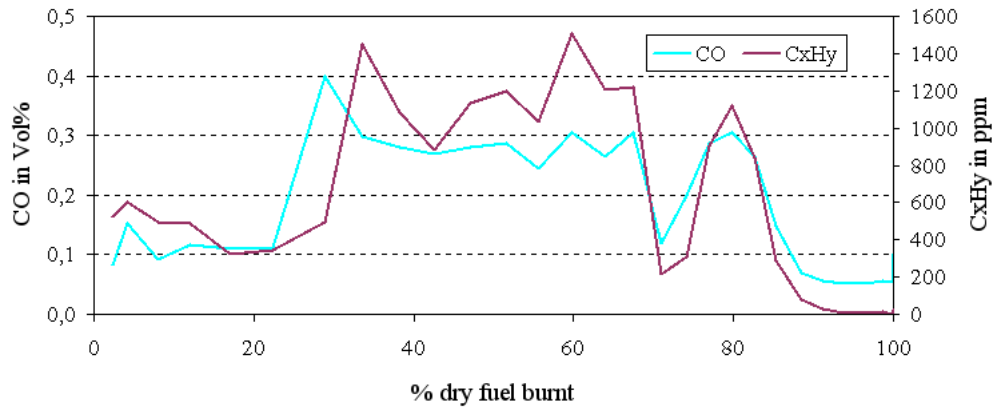

(d)

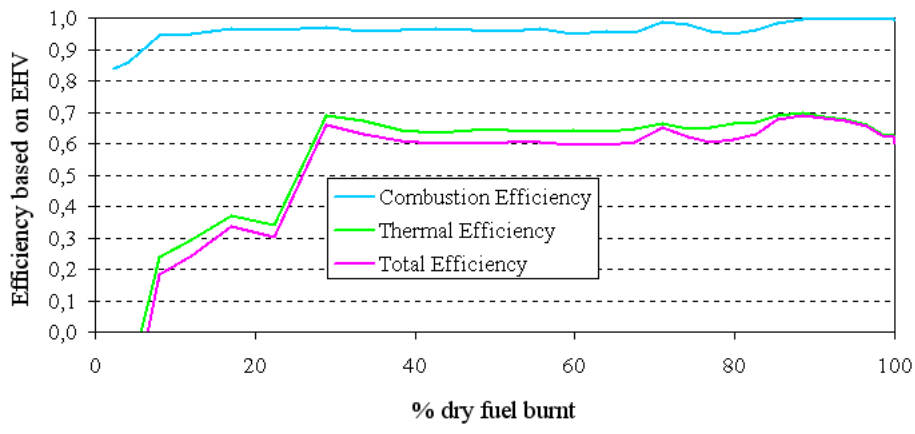

(e)

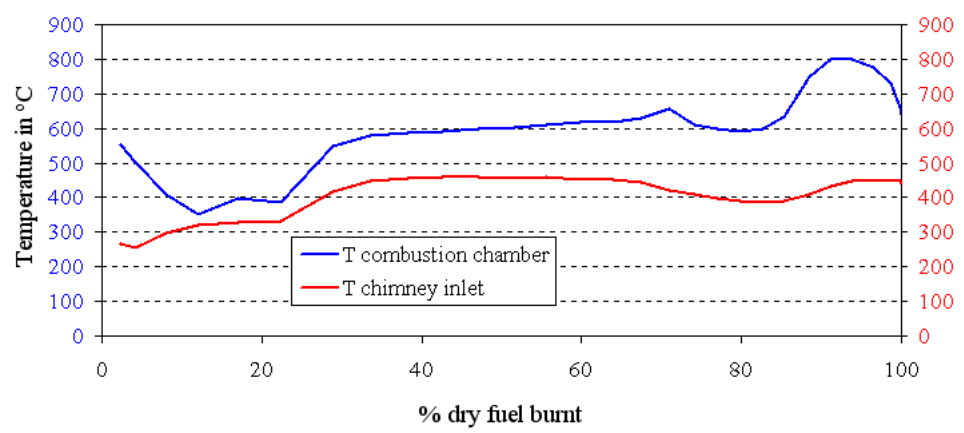

(f)

Figure B.11: Test 19 - Graphs (d)-(f)

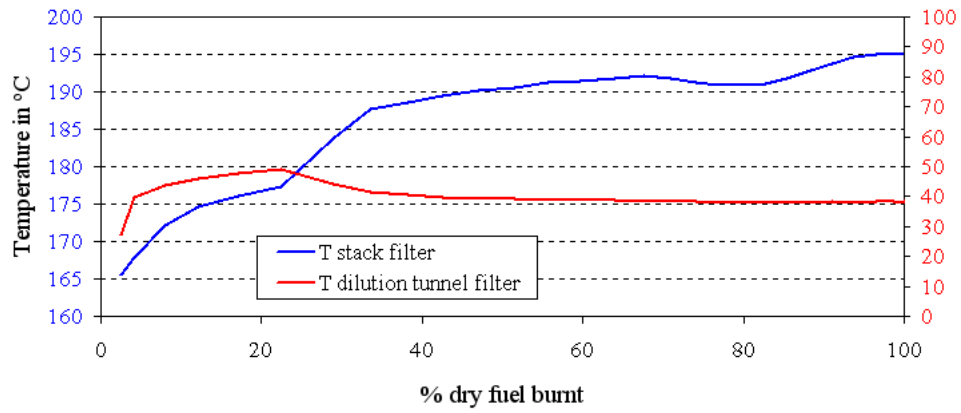

(g)

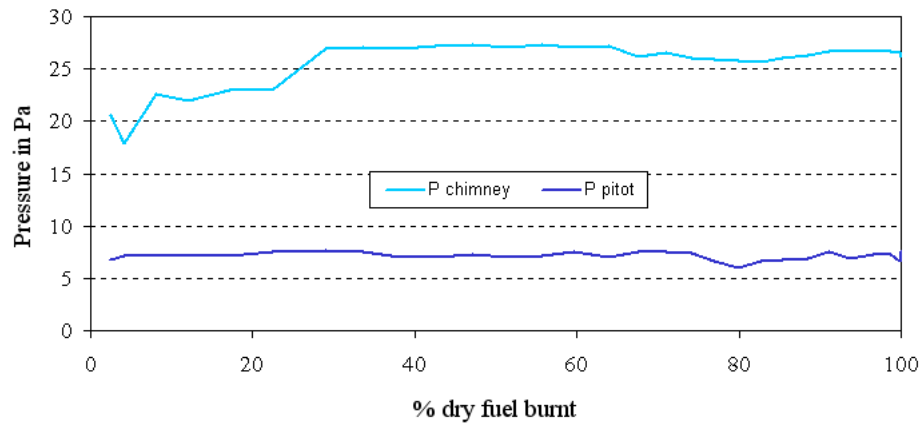

(h)

Figure B.12: Test 19 - Graphs (g)-(h)

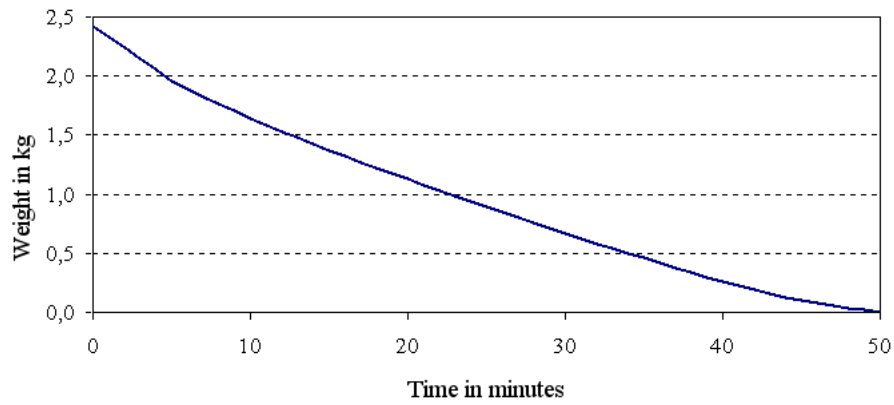

(a)

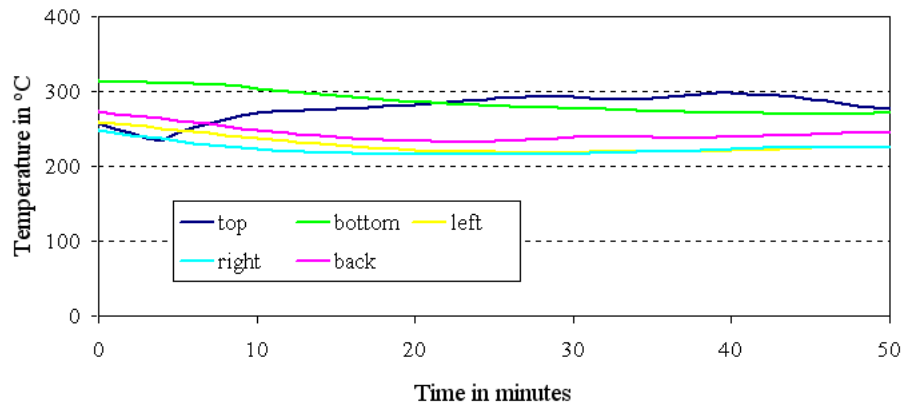

(b)

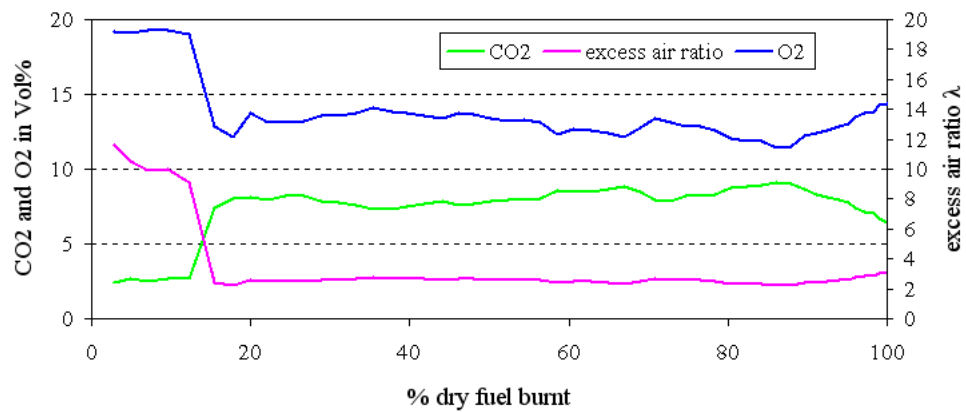

(c)

Figure B.13: Test 20 - Graphs (a)-(c)

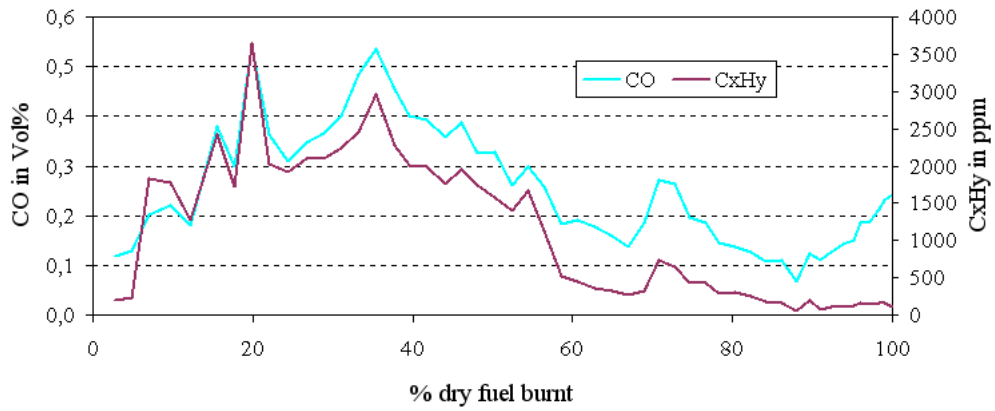

(d)

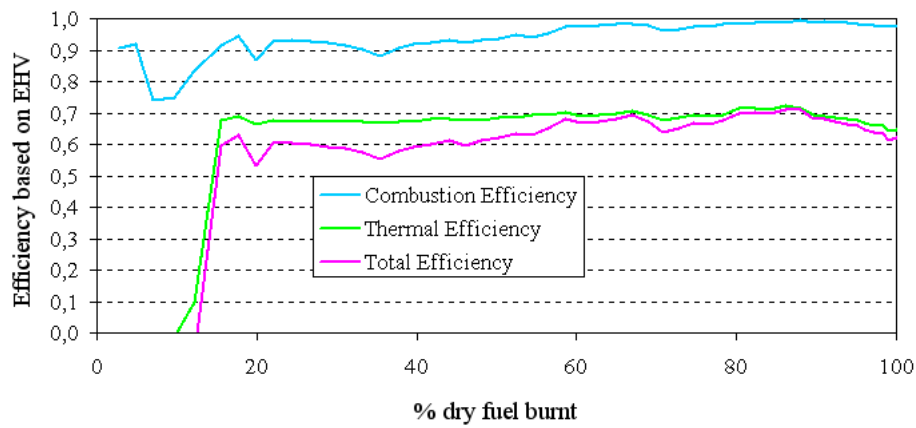

(e)

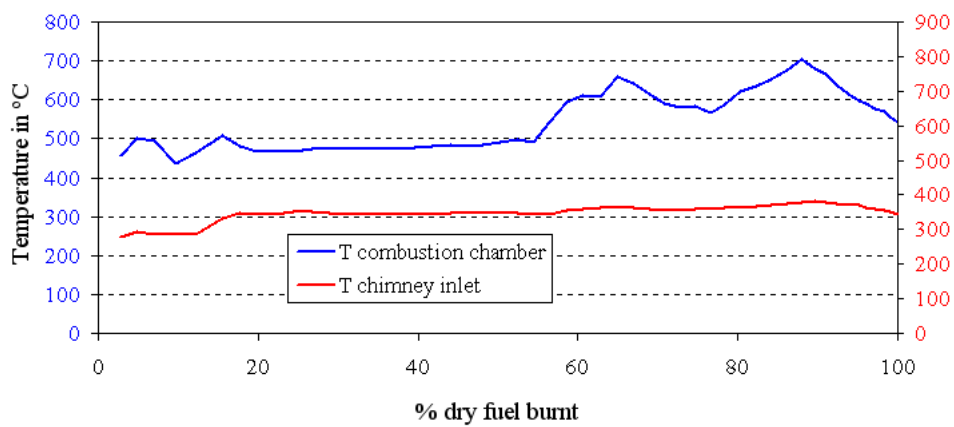

(f)

Figure B.14: Test 20 - Graphs (d)-(f)



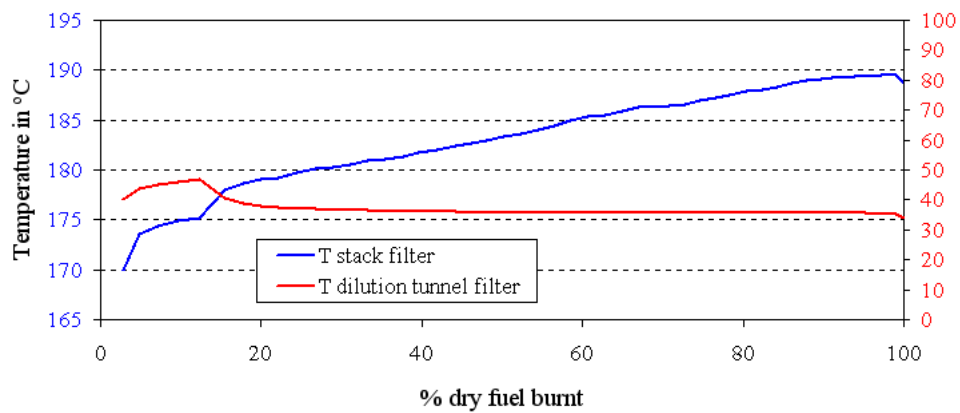

(g)

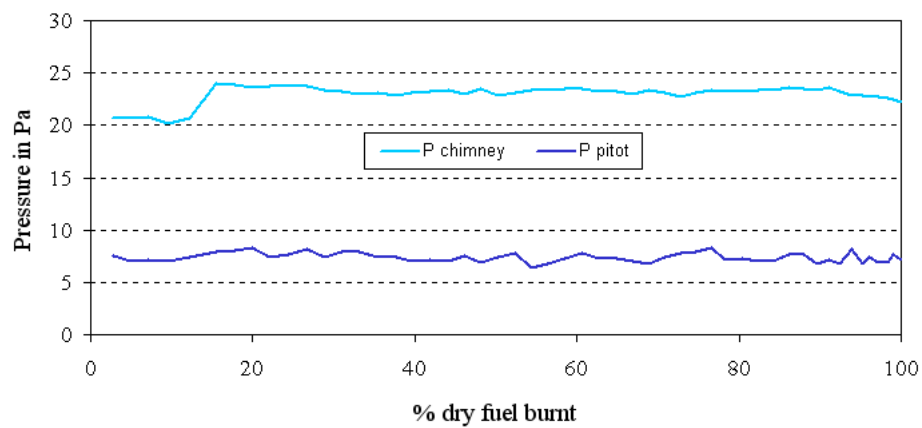

(h)

Figure B.15: Test 20 - Graphs (g)-(h)

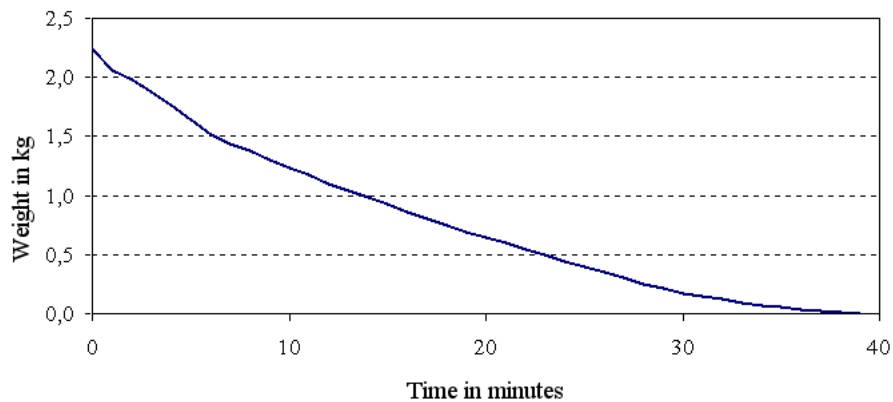

(a)

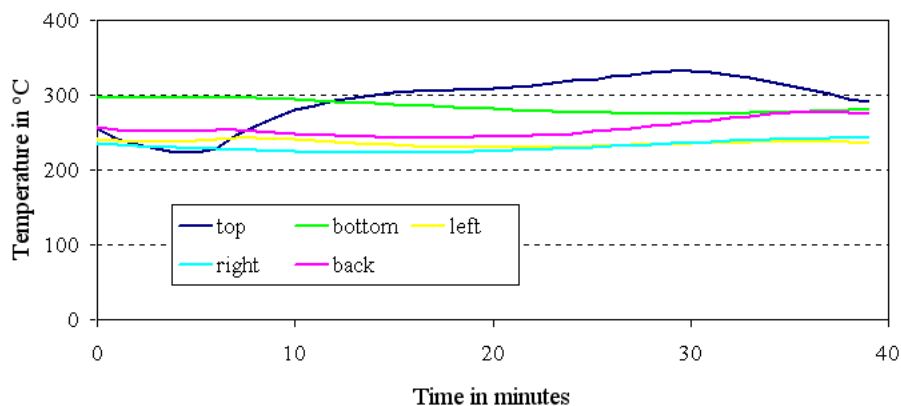

(b)

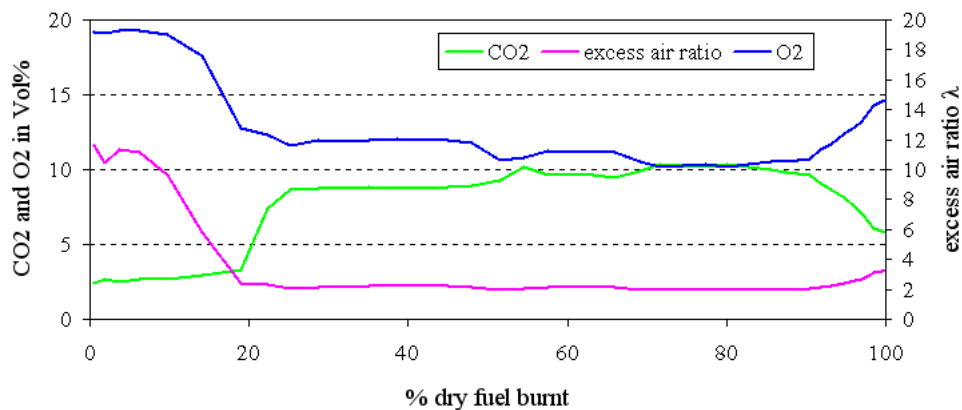

(c)

Figure B.16: Test 21 - Graphs (a)-(c)

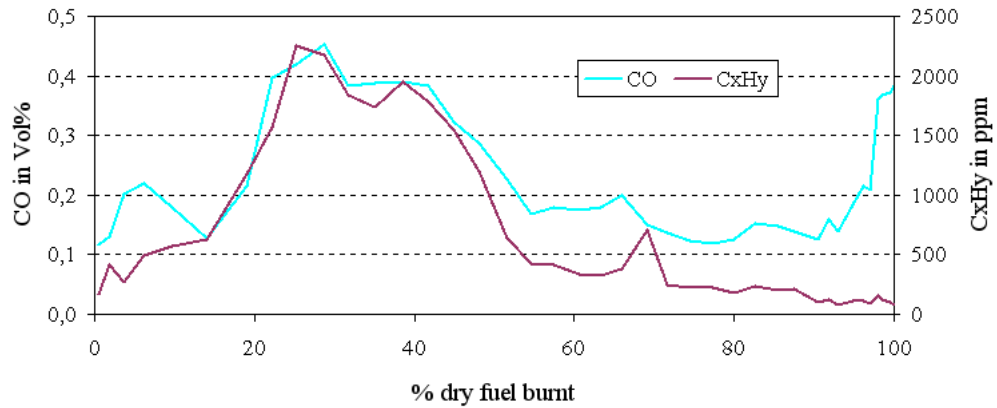

(d)

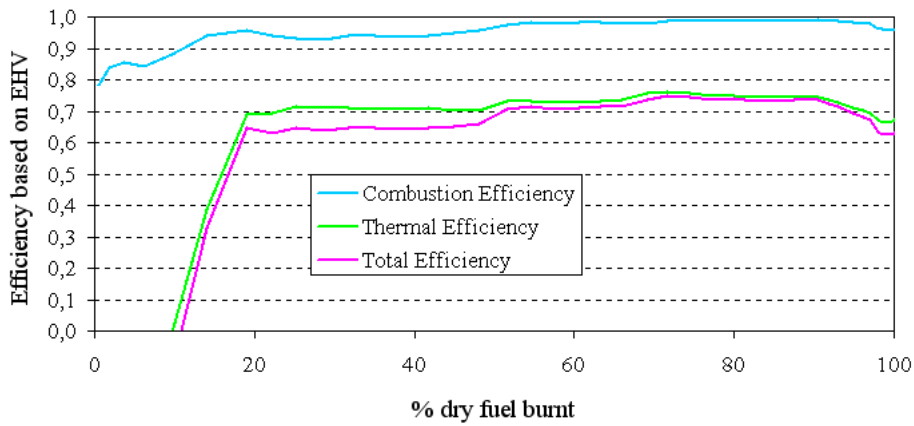

(e)

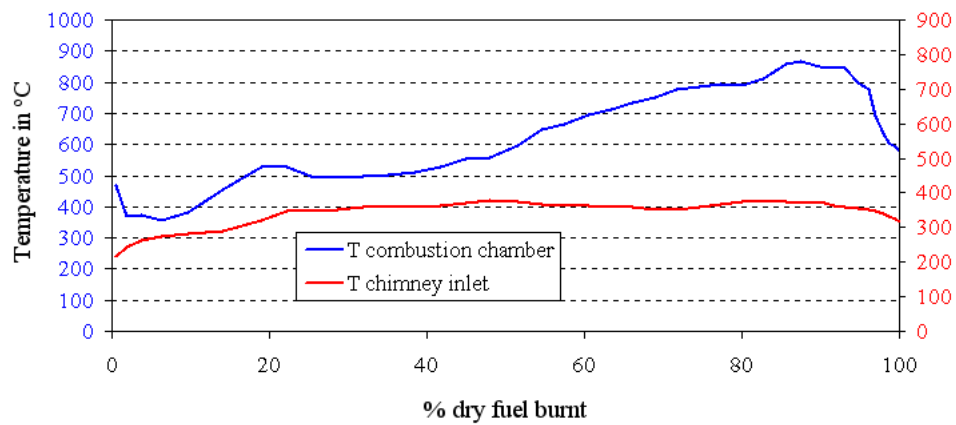

(f)

Figure B.17: Test 21 - Graphs (d)-(f)

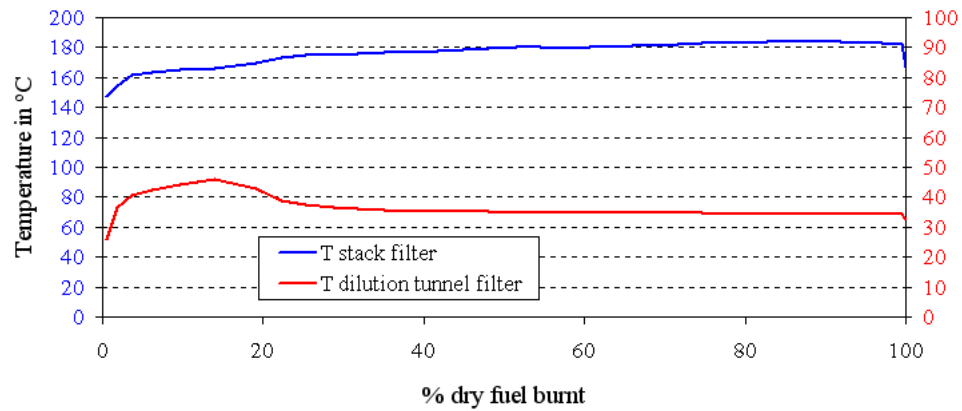

(g)

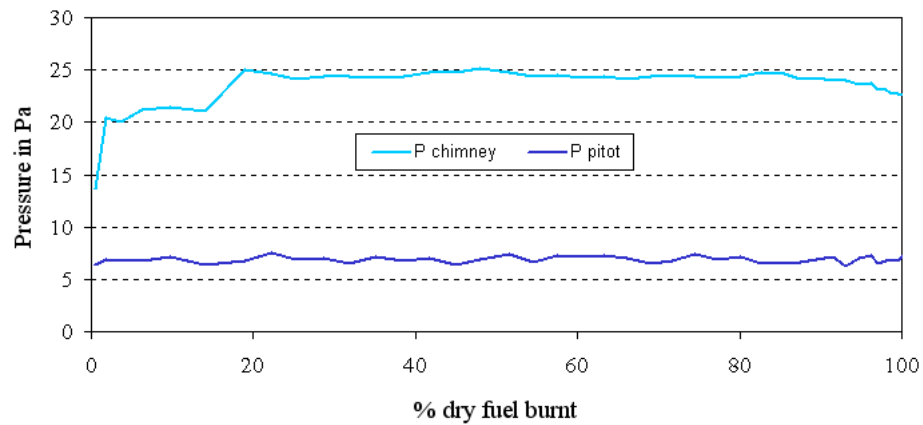

(h)

Figure B.18: Test 21 - Graphs (g)-(h)

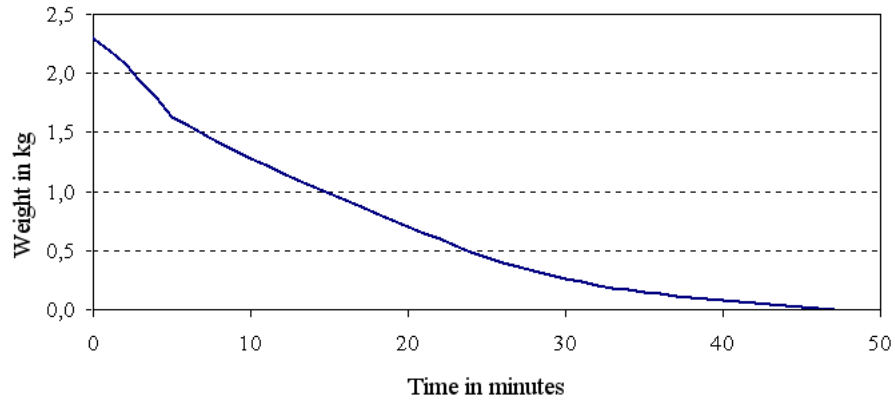

(a)

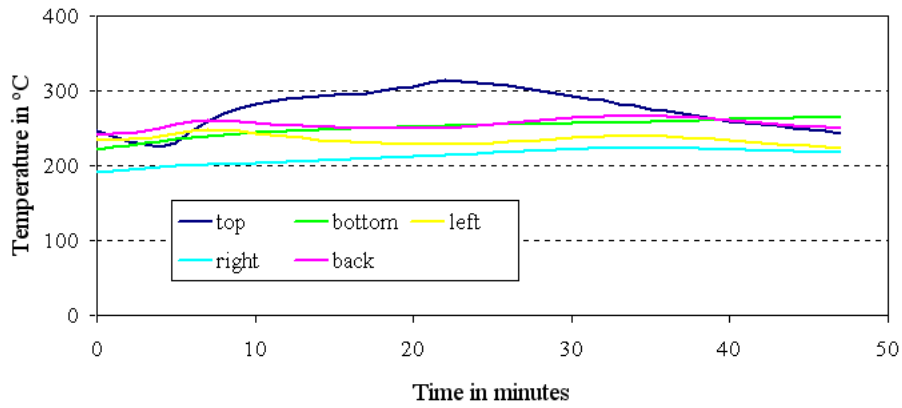

(b)

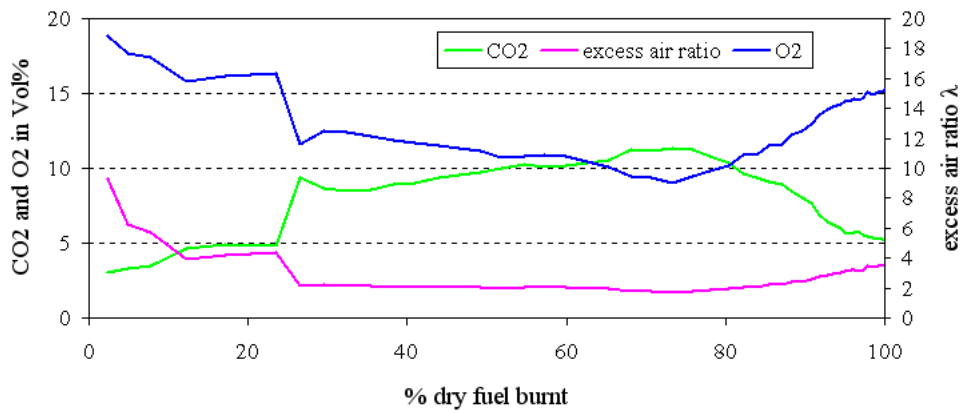

(c)

Figure B.19: Test 22 - Graphs (a)-(c)

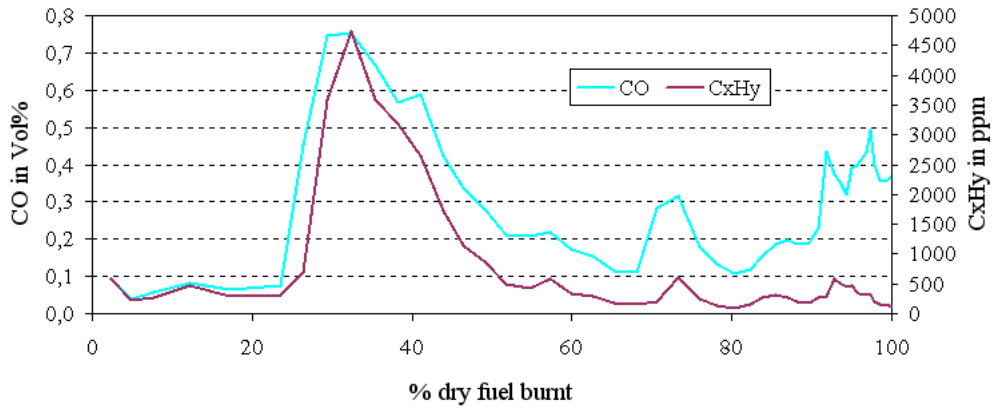

(d)

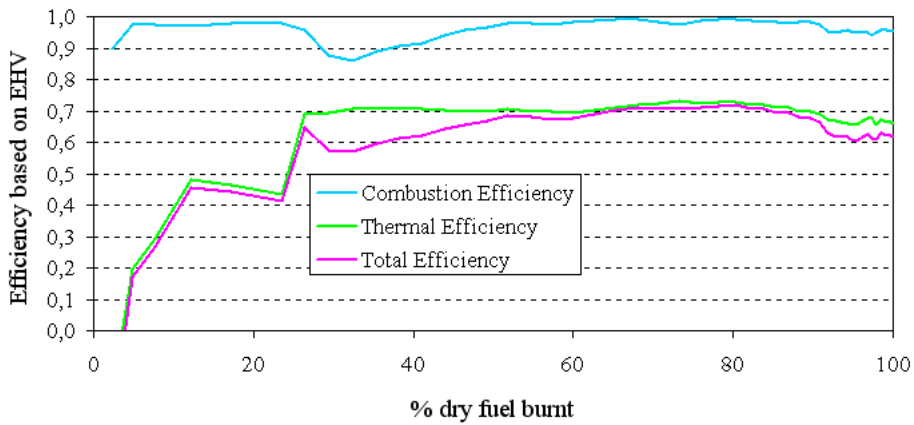

(e)

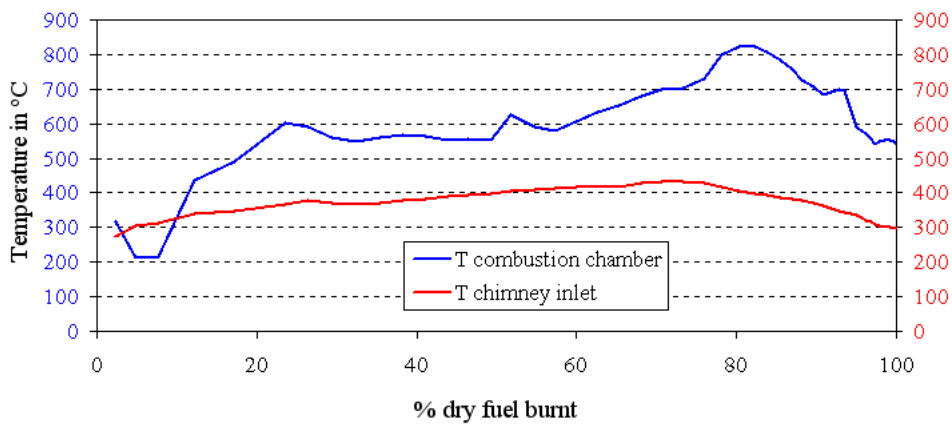

(f)

Figure B.20: Test 22 - Graphs (d)-(f)

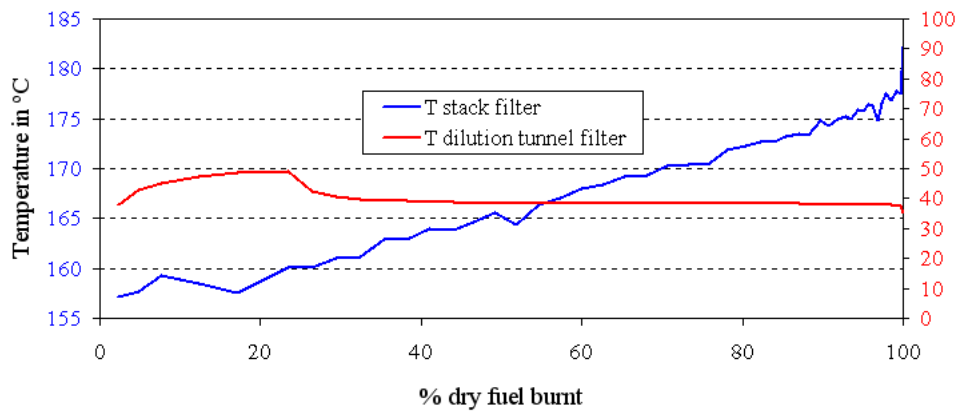

(g)

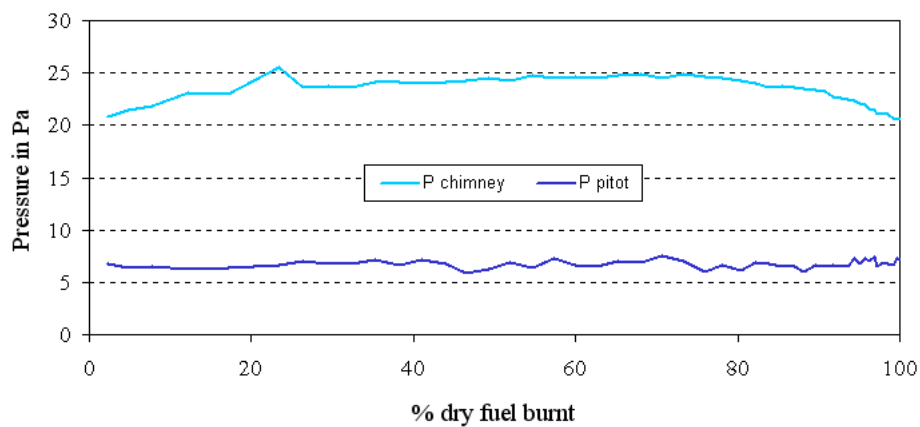

(h)

Figure B.21: Test 22 - Graphs (g)-(h)

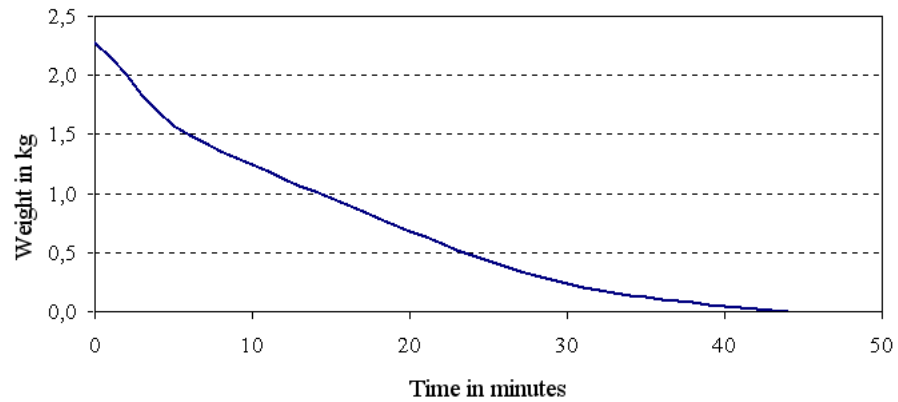

(a)

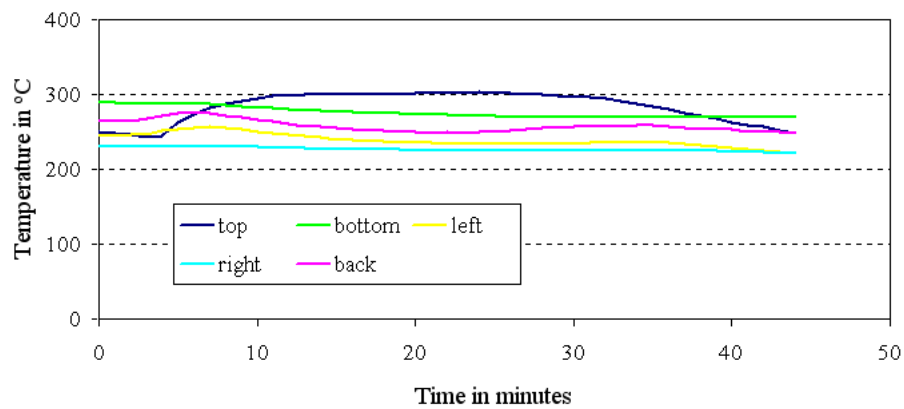

(b)

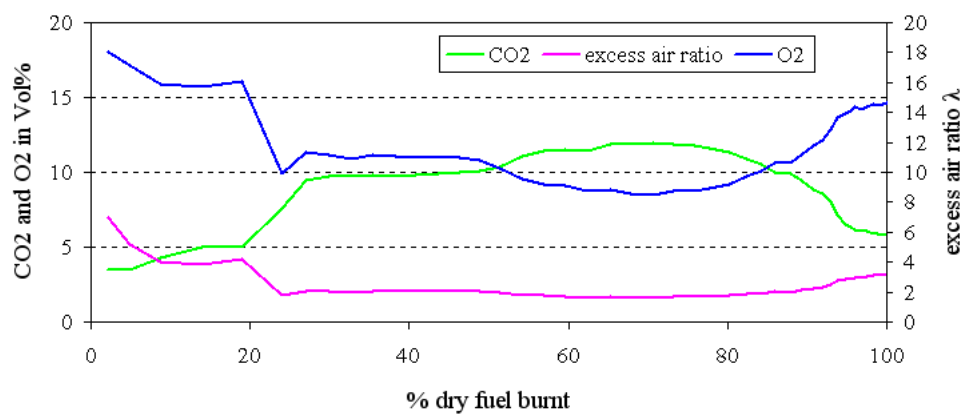

(c)

Figure B.22: Test 23 - Graphs (a)-(c)



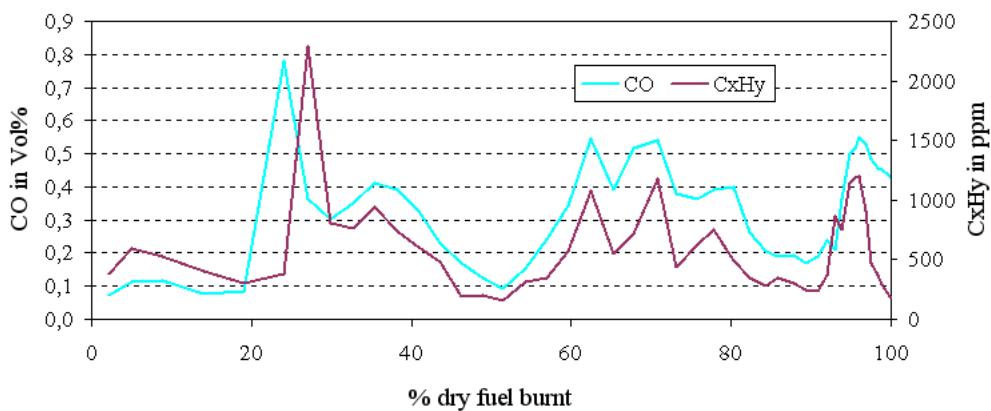

(d)

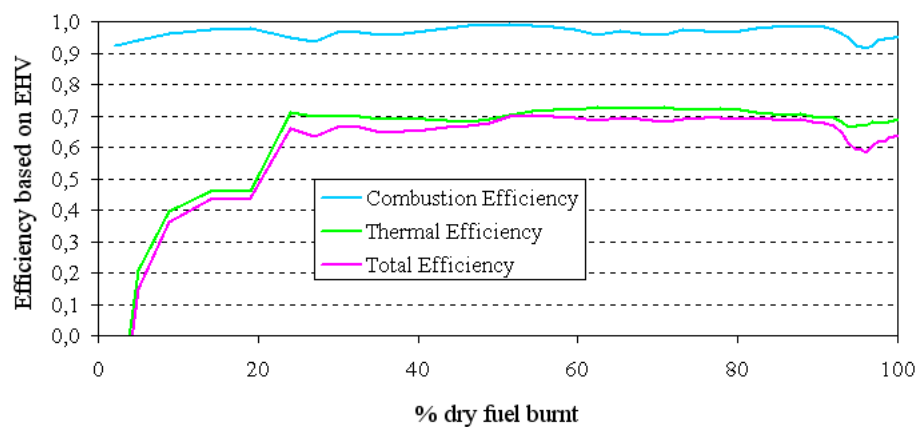

(e)

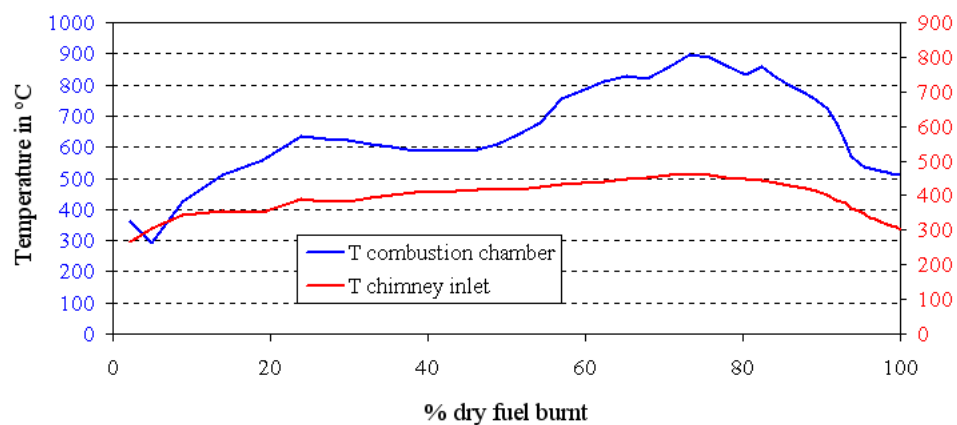

(f)

Figure B.23: Test 23 - Graphs (d)-(f)

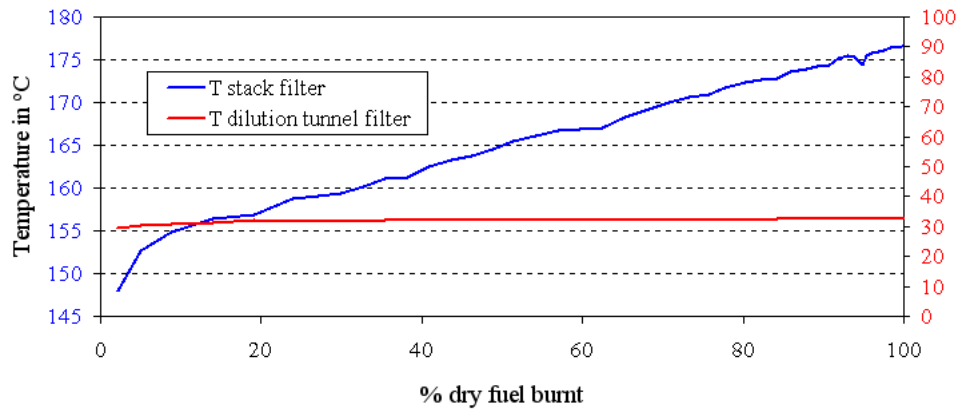

(g)

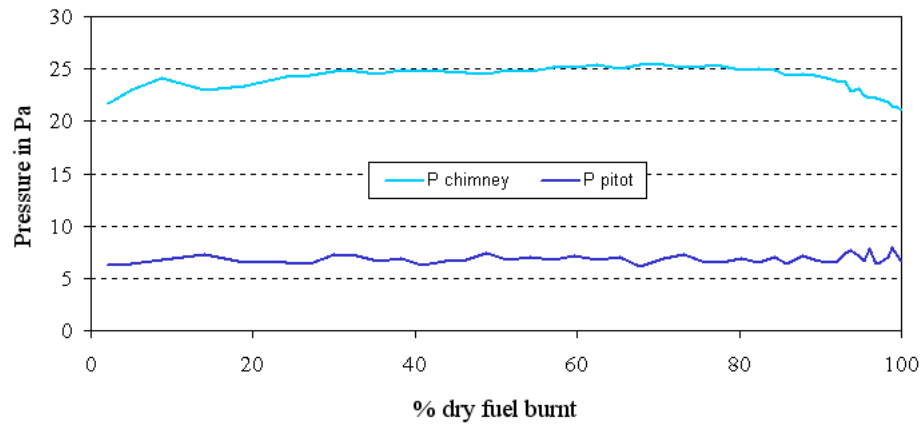

(h)

Figure B.24: Test 23 - Graphs (g)-(h)

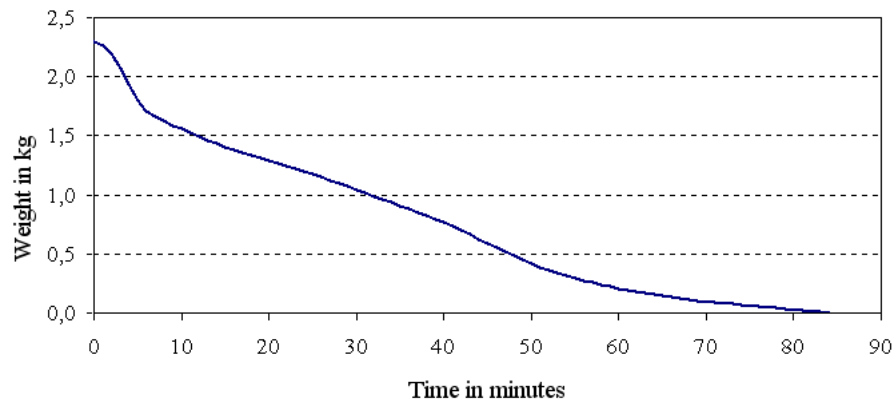

(a)

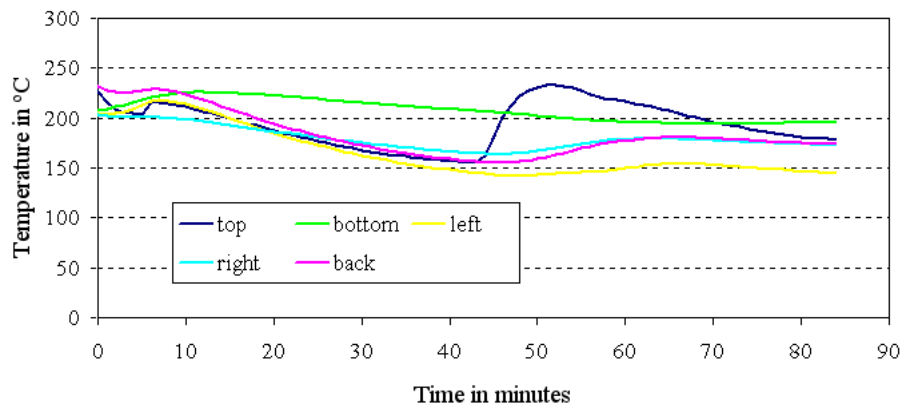

(b)

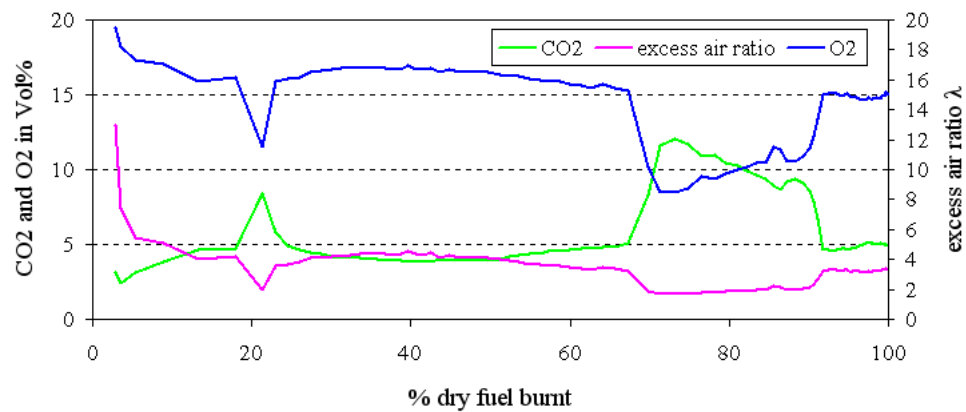

(c)

Figure B.25: Test 30 - Graphs (a)-(c)

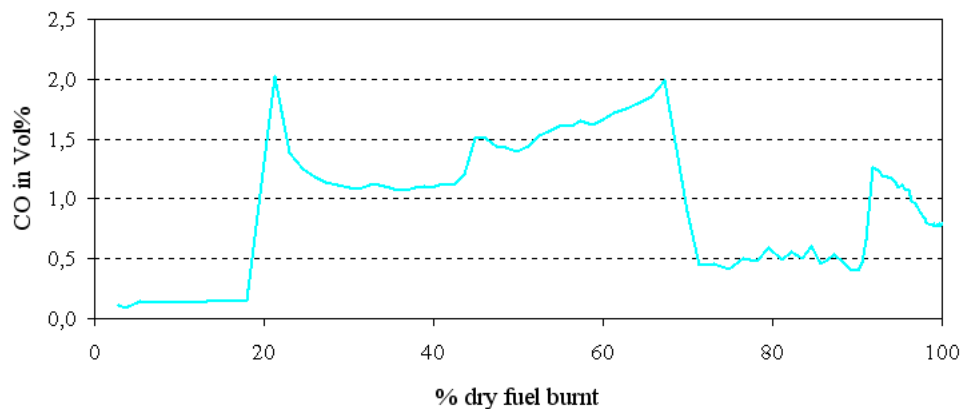

(d)

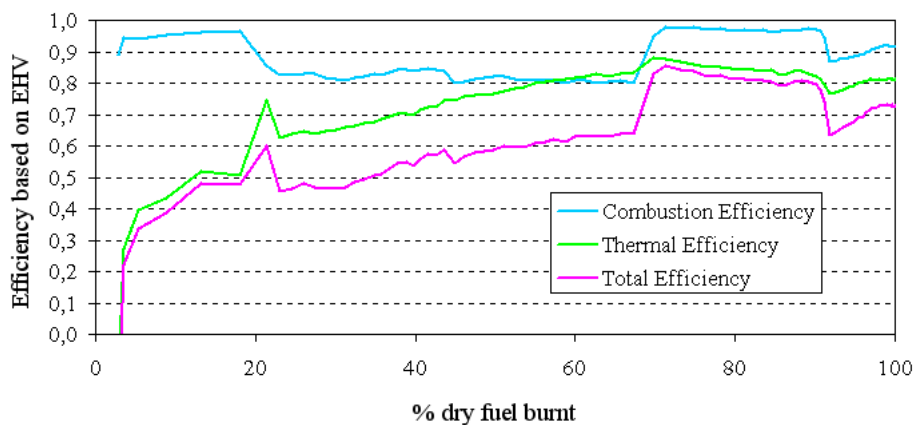

(e)

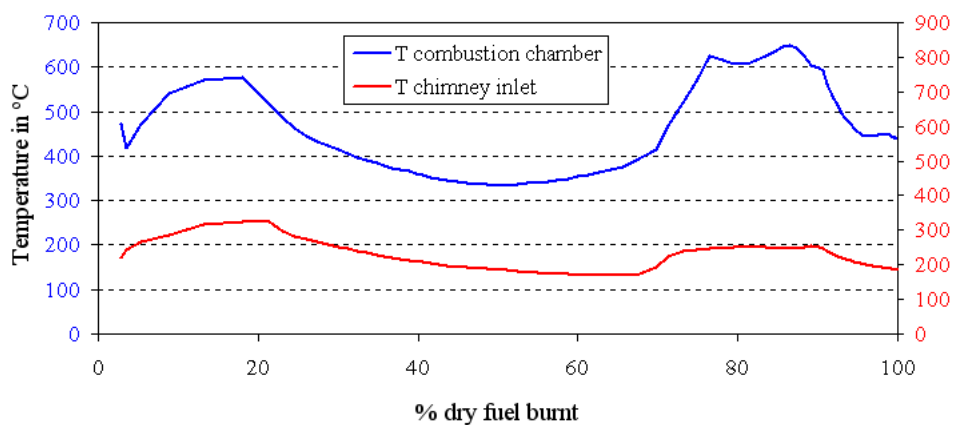

(f)

Figure B.26: Test 30 - Graphs (d)-(f)

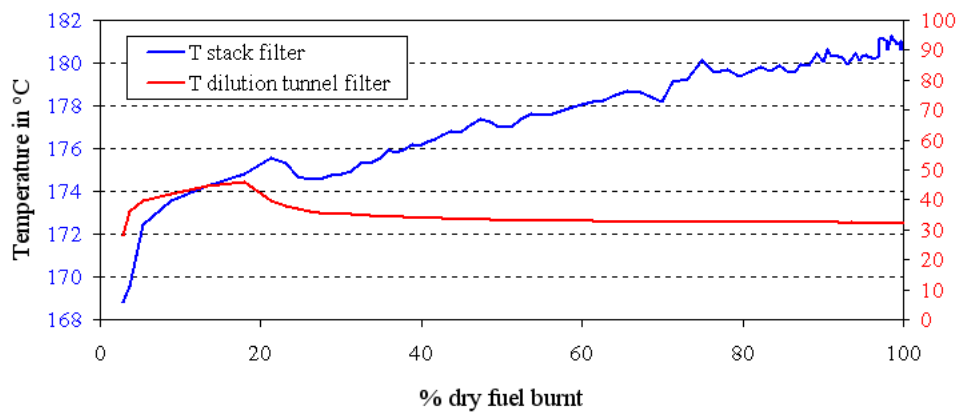

(g)

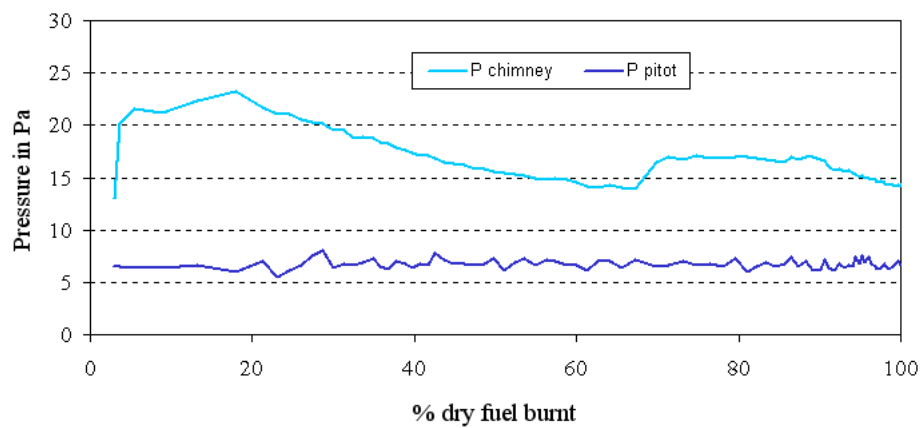

(h)

Figure B.27: Test 30 - Graphs (g)-(h)

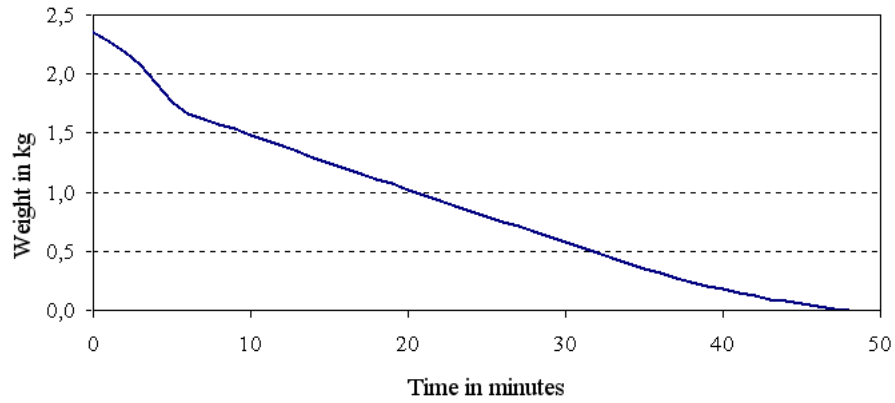

(a)

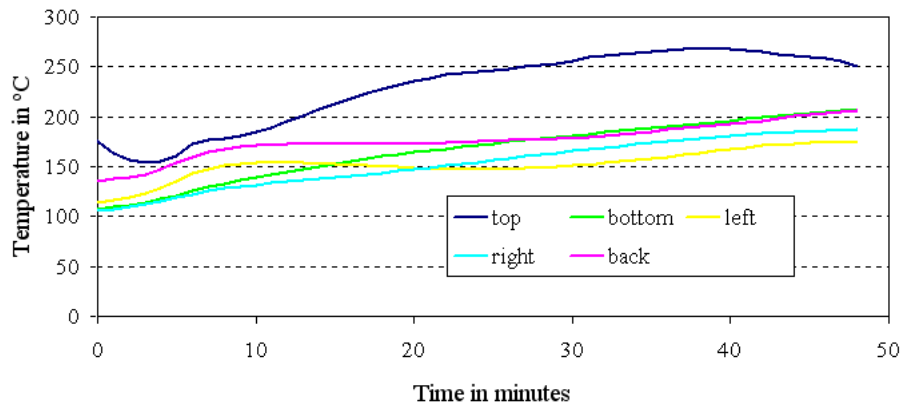

(b)

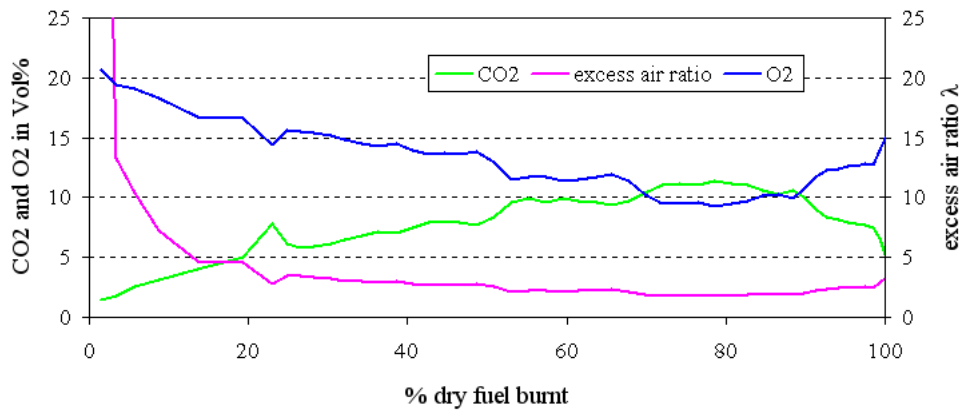

(c)

Figure B.28: Test 31 - Graphs (a)-(c)

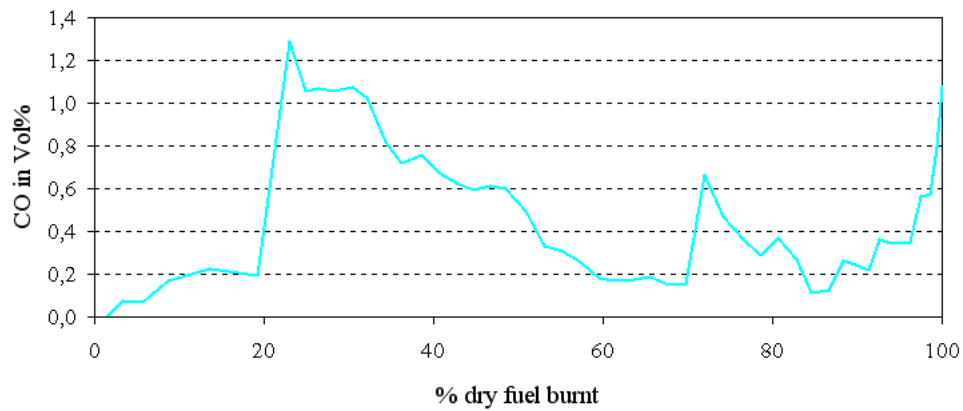

(d)

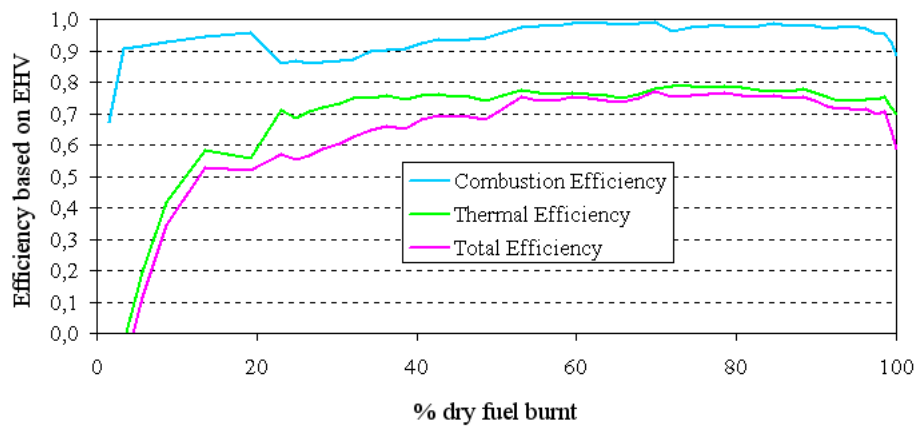

(e)

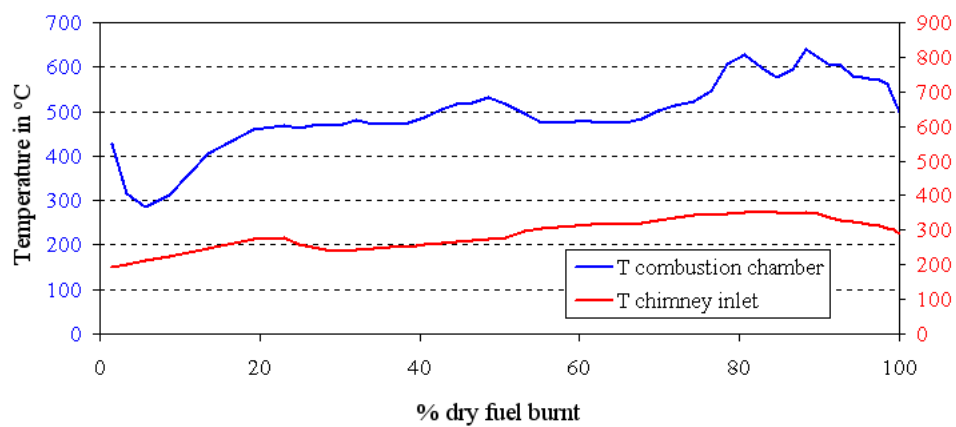

(f)

Figure B.29: Test 31 - Graphs (d)-(f)

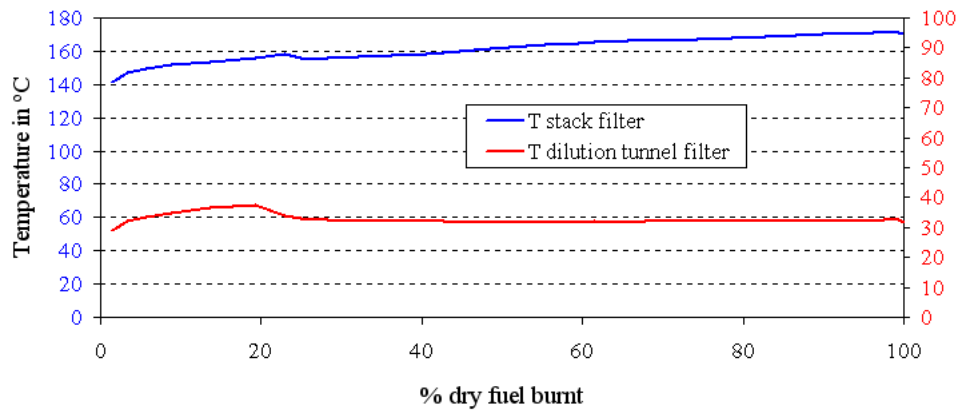

(g)

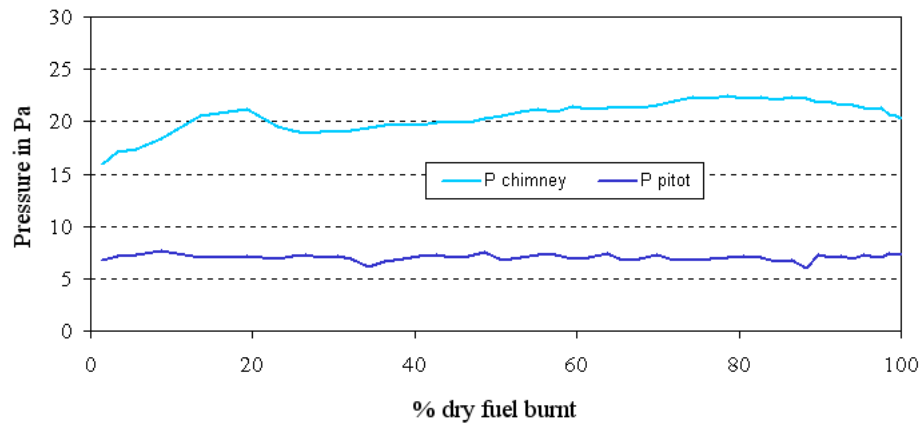

(h)

Figure B.30: Test 31 - Graphs (g)-(h)



# Appendix C

## EN-13240 Graphs

The subtitles of the following graphs correspond to:

- (a) Fuel burnt against time
- (b) CO<sub>2</sub> and O<sub>2</sub> content in the dry flue gas in Vol% against time
- (c) Total hydrocarbon content in the dry flue gas in ppm and CO content in the dry flue gas in Vol% against time<sup>1</sup>
- (d) Combustion chamber and chimney inlet temperatures against time
- (e) Stack and dilution tunnel filter temperatures against time
- (f) Pitot and chimney negative pressures against time

---

<sup>1</sup>Only Tests 35 and 36 include Total hydrocarbon content



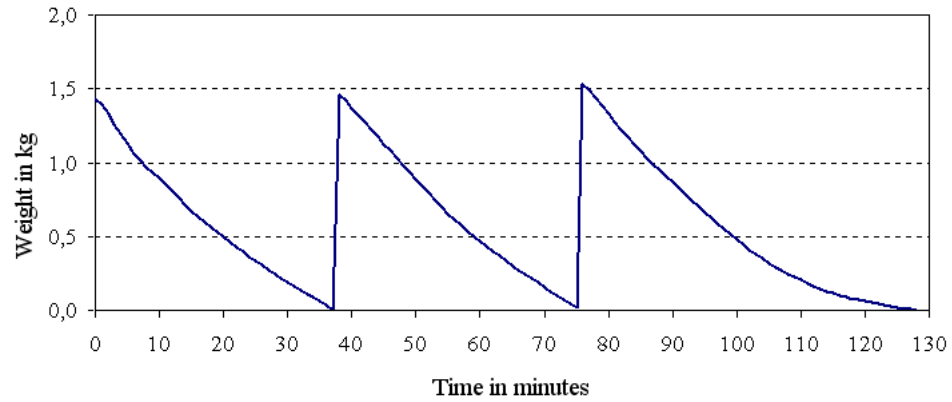

(a)

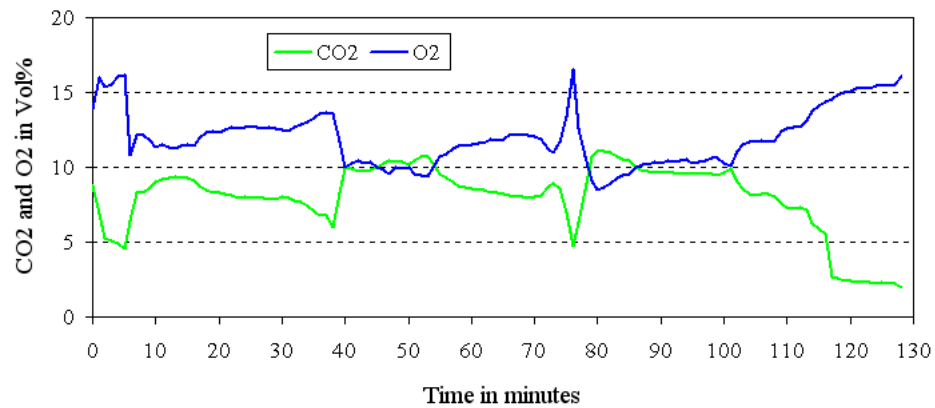

(b)

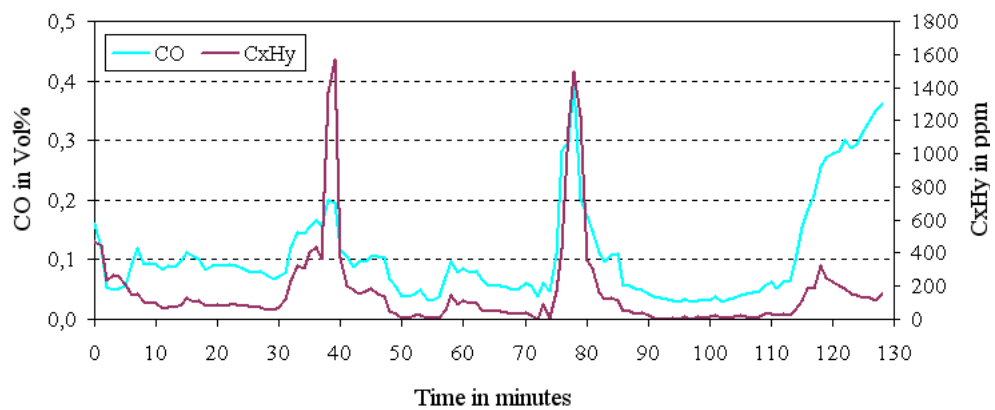

(c)

Figure C.1: Test 35 - Graphs (a)-(c)

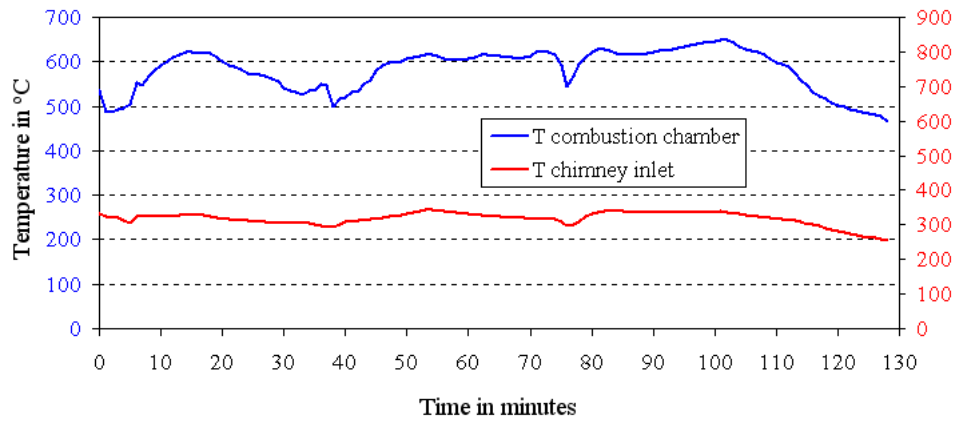

(d)

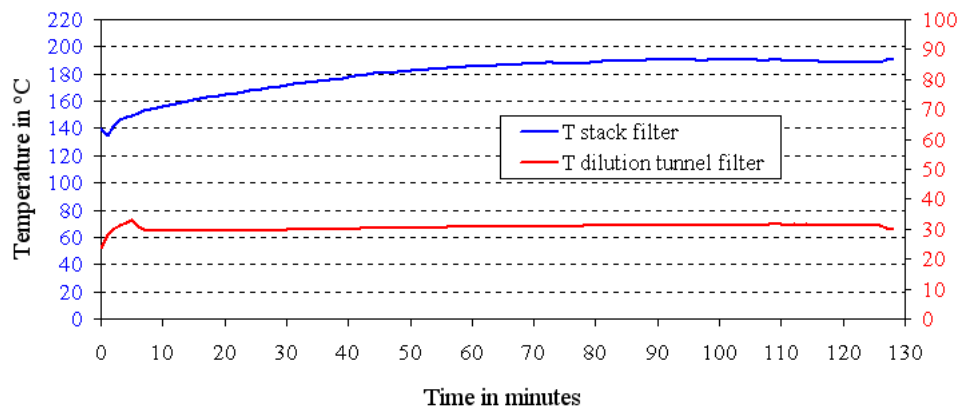

(e)

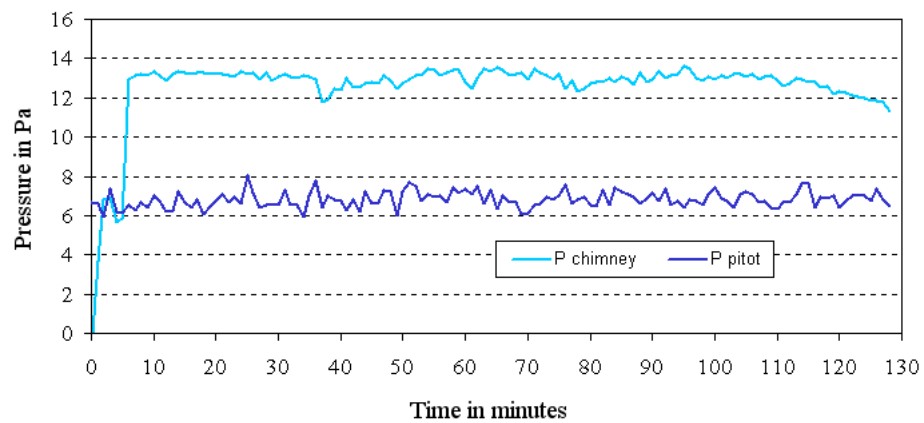

(f)

Figure C.2: Test 35 - Graphs (d)-(f)

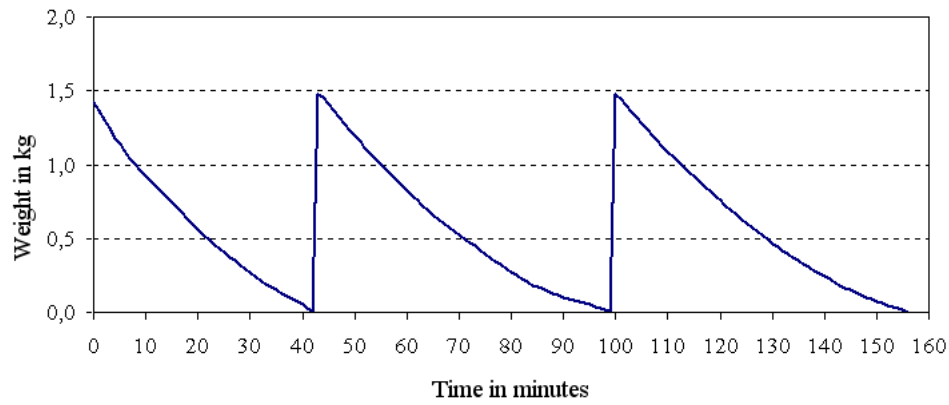

(a)

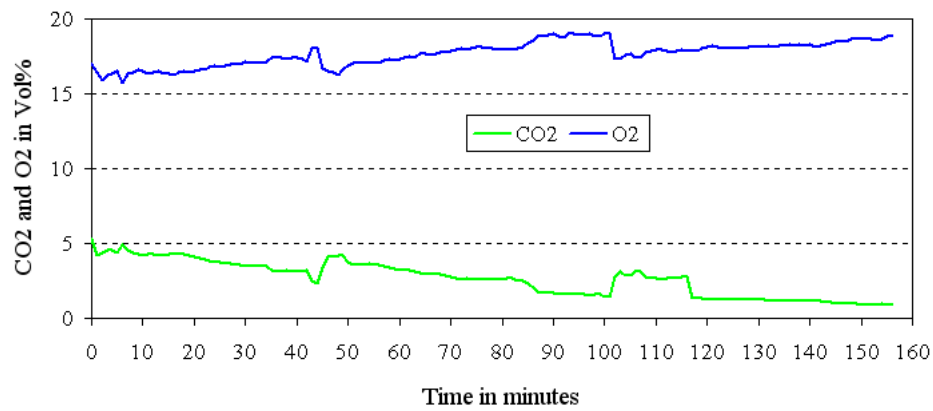

(b)

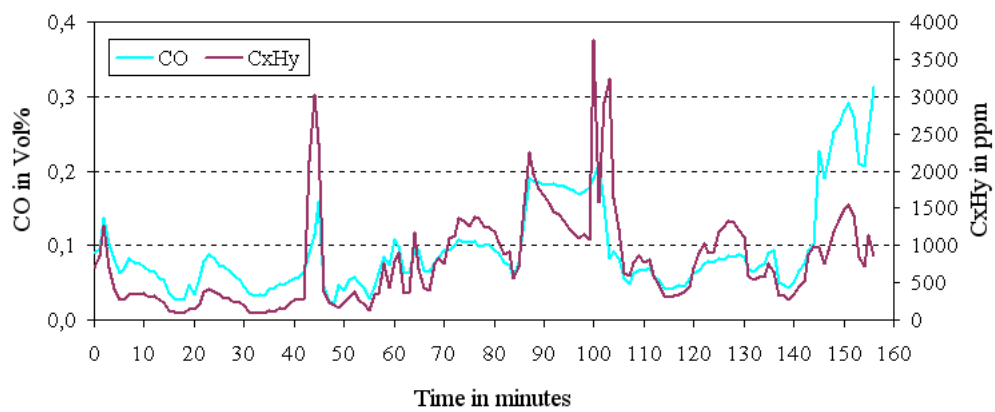

(c)

Figure C.3: Test 36 - Graphs (a)-(c)

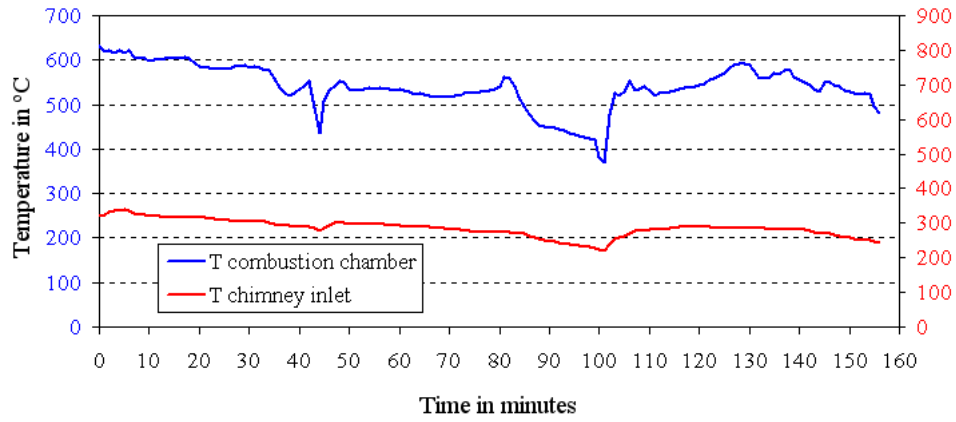

(d)

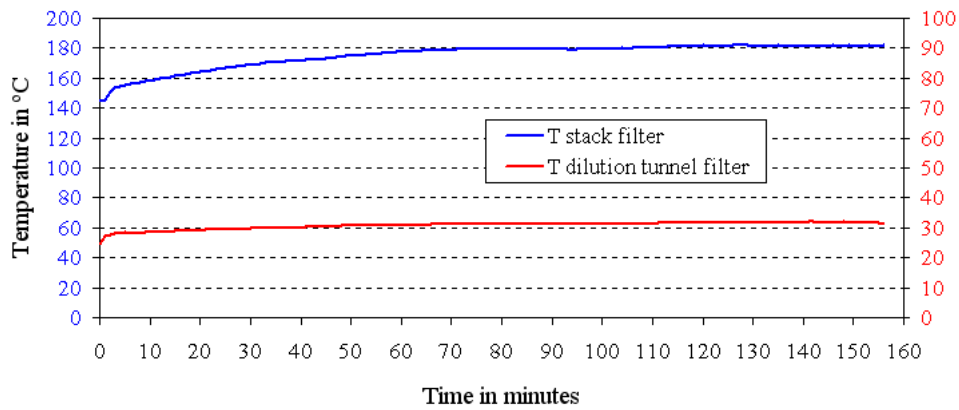

(e)

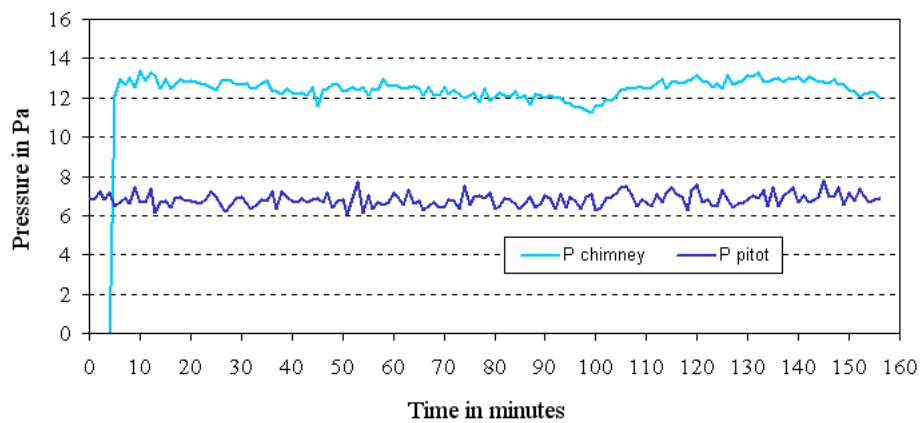

(f)

Figure C.4: Test 36 - Graphs (d)-(f)

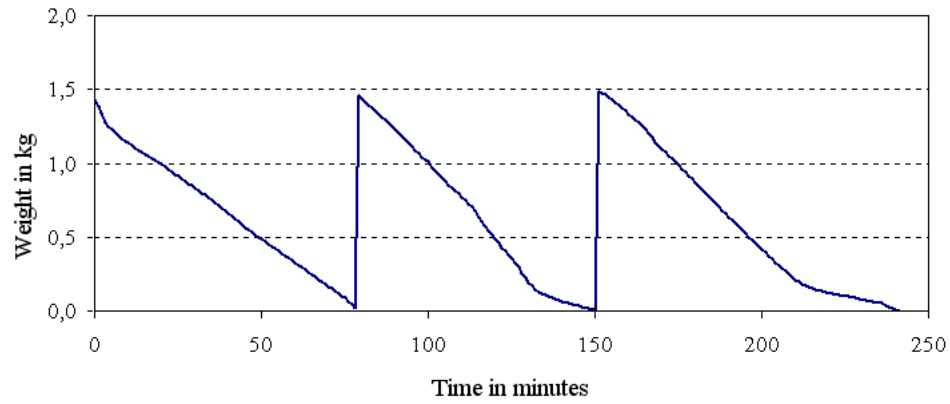

(a)

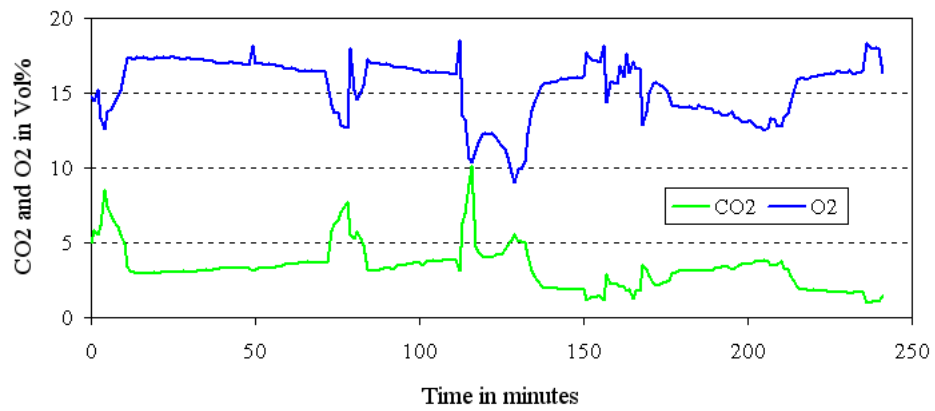

(b)

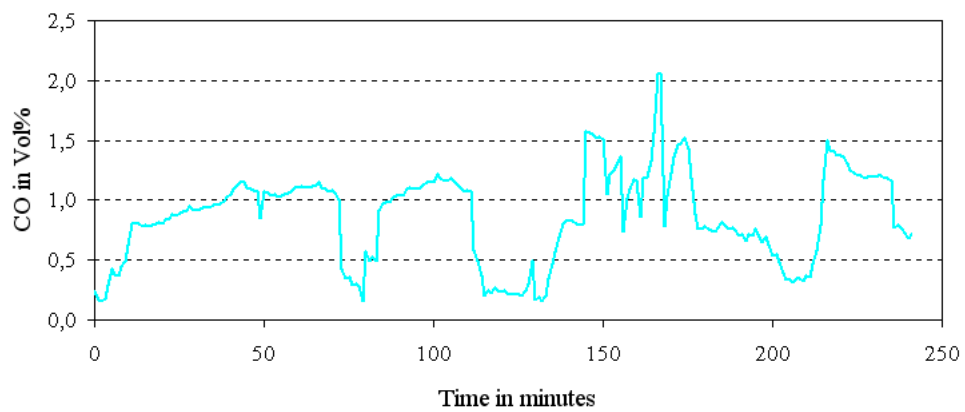

(c)

Figure C.5: Test 37 - Graphs (a)-(c)

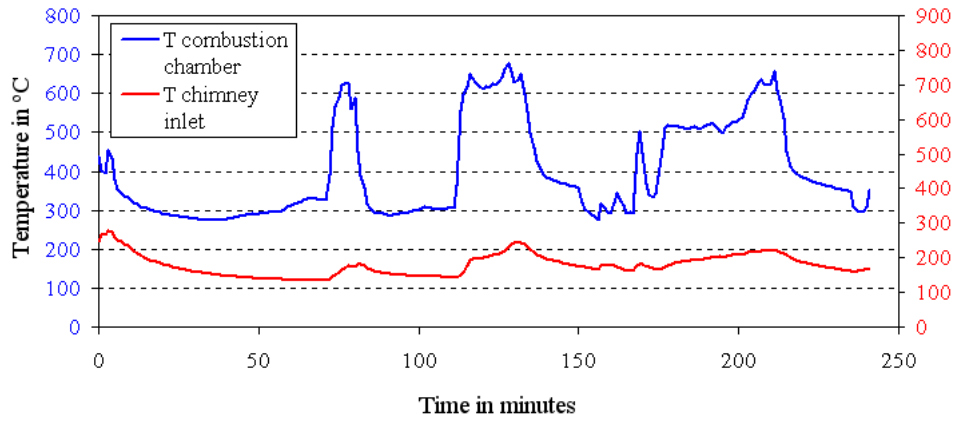

(d)

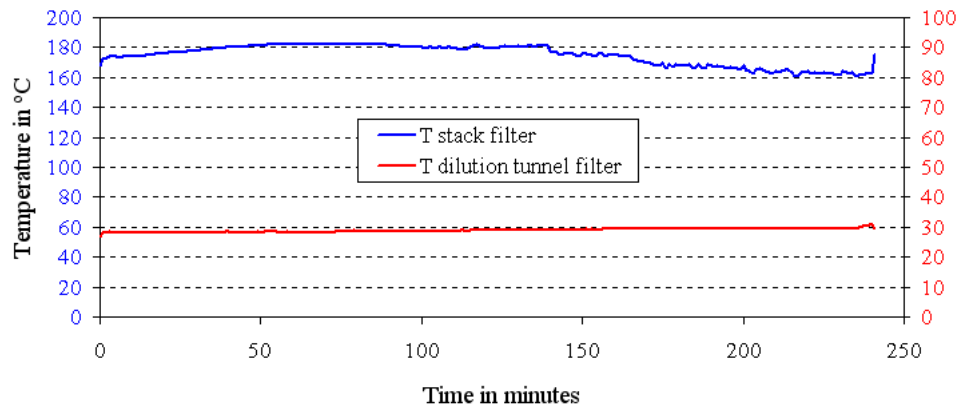

(e)

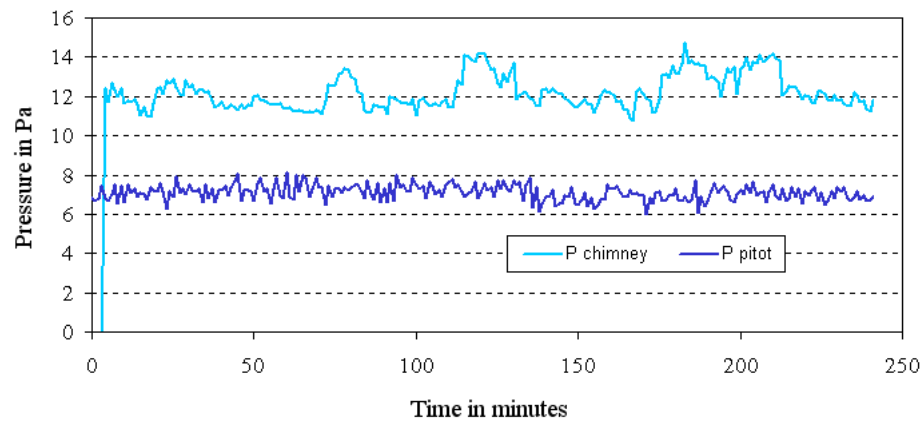

(f)

Figure C.6: Test 37 - Graphs (d)-(f)



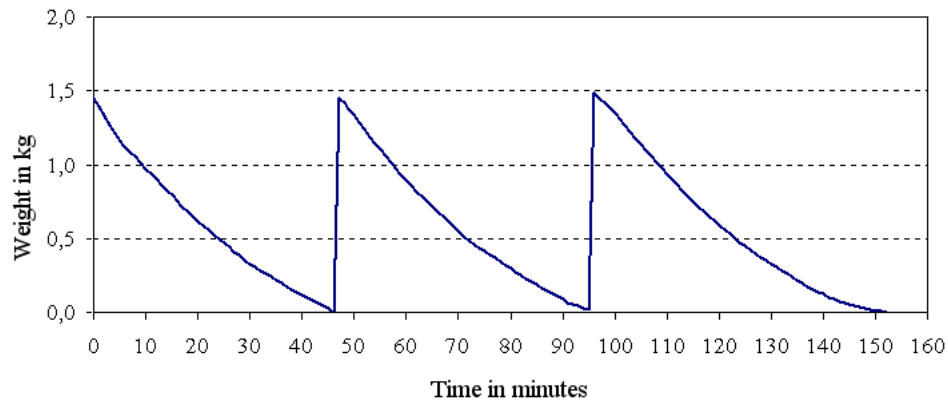

(a)

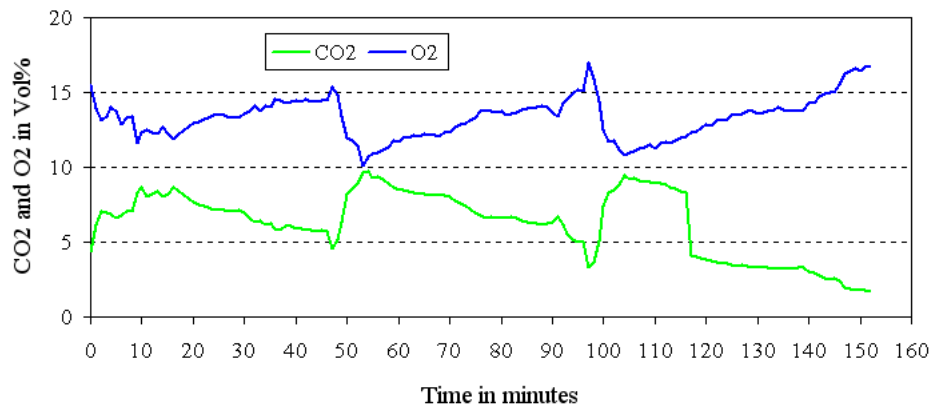

(b)

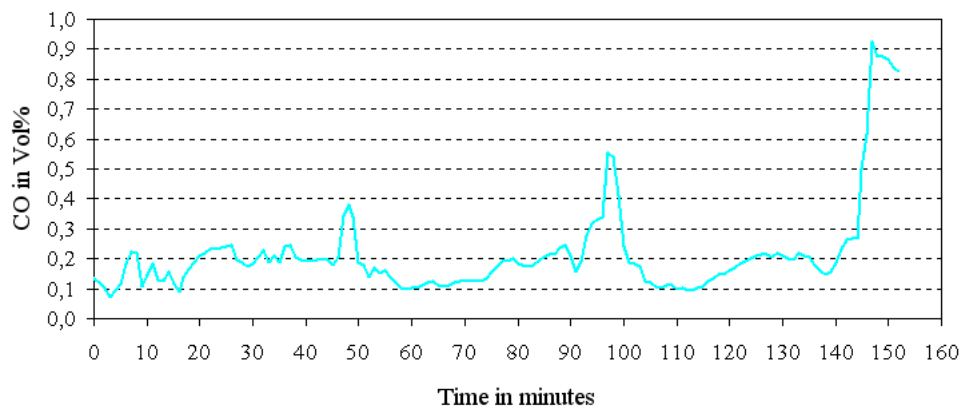

(c)

Figure C.7: Test 38 - Graphs (a)-(c)

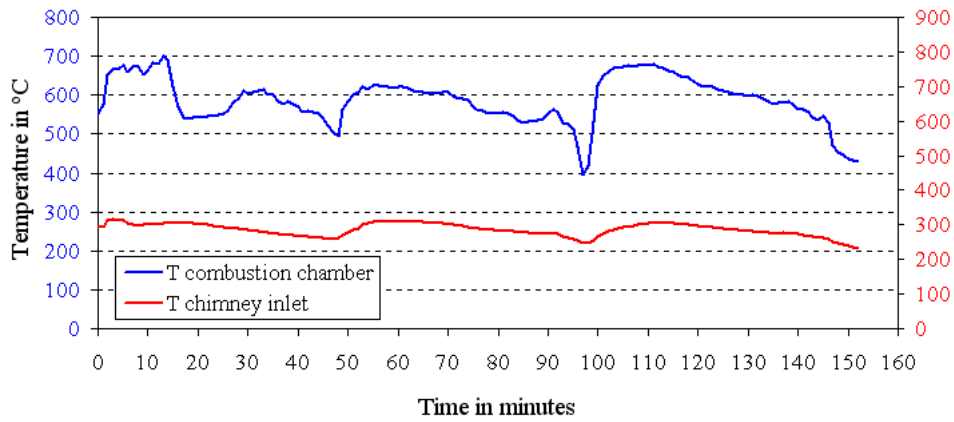

(d)

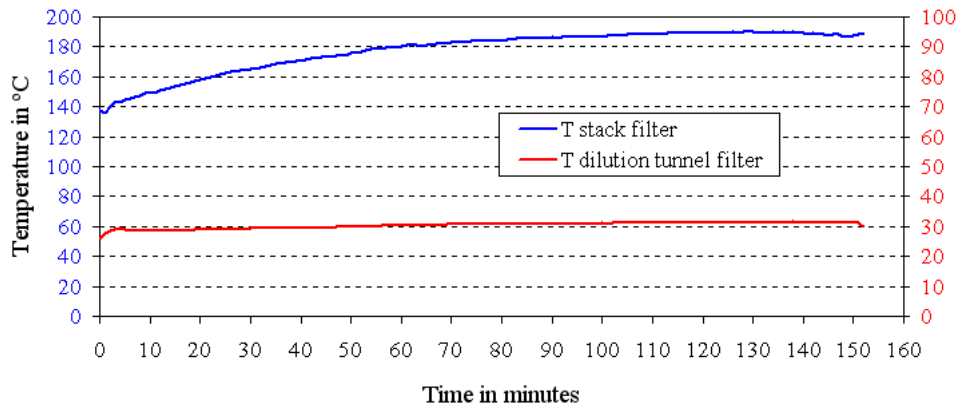

(e)

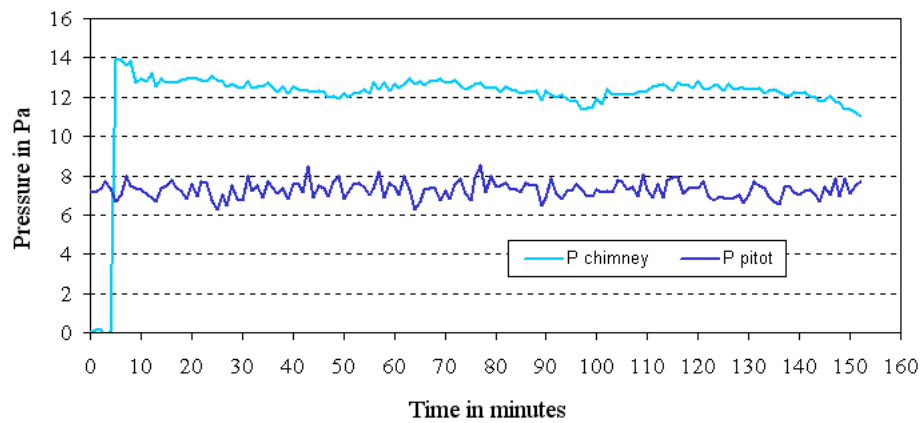

(f)

Figure C.8: Test 38 - Graphs (d)-(f)

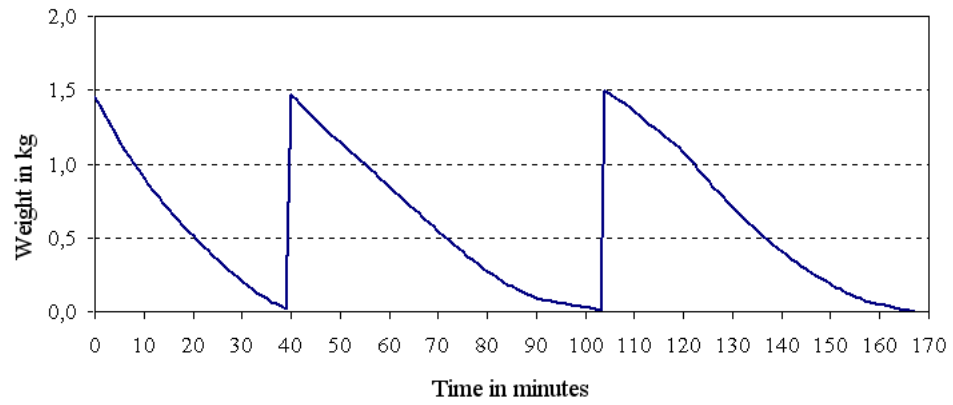

(a)

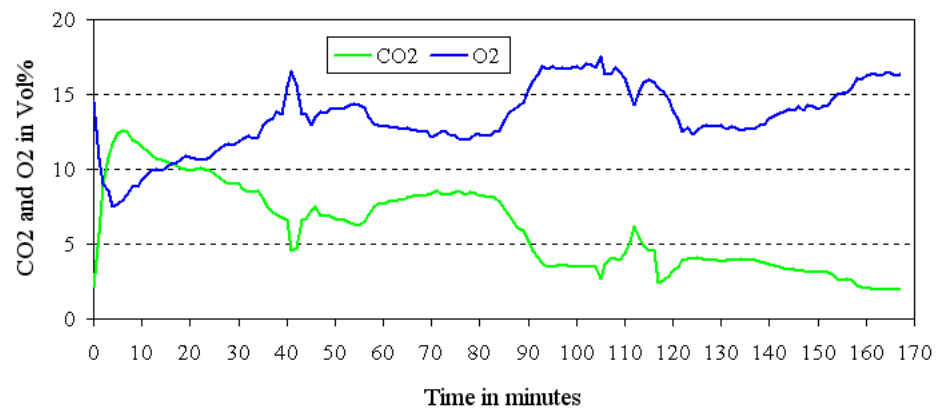

(b)

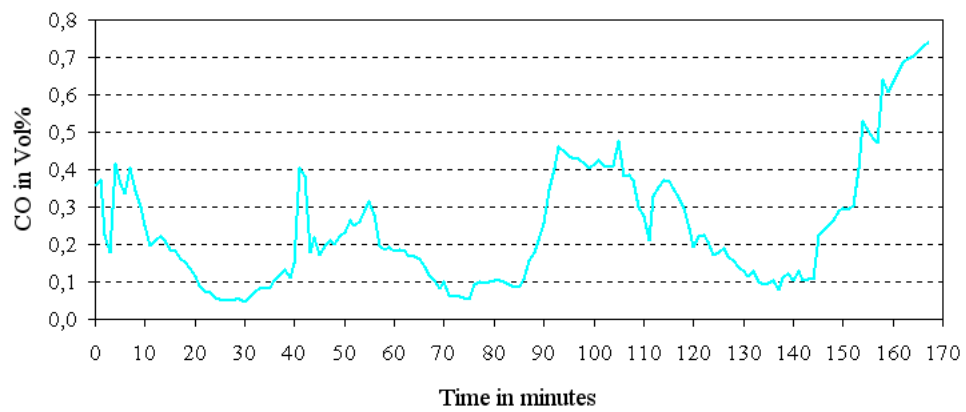

(c)

Figure C.9: Test 39 - Graphs (a)-(c)

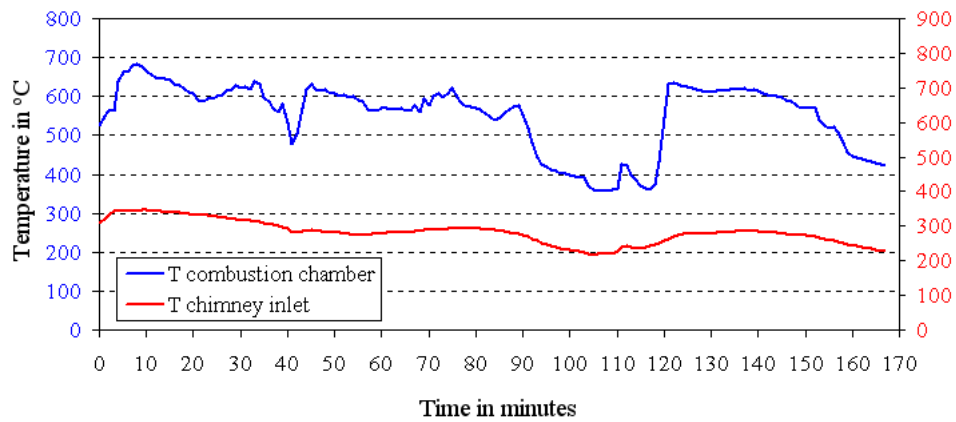

(d)

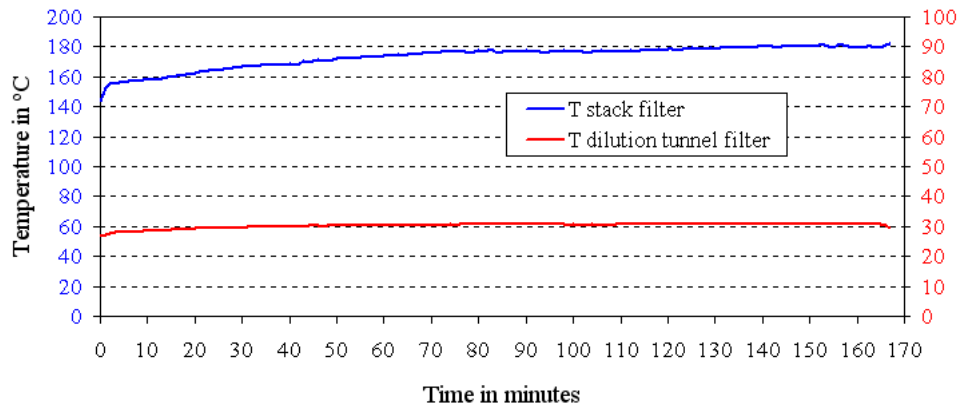

(e)

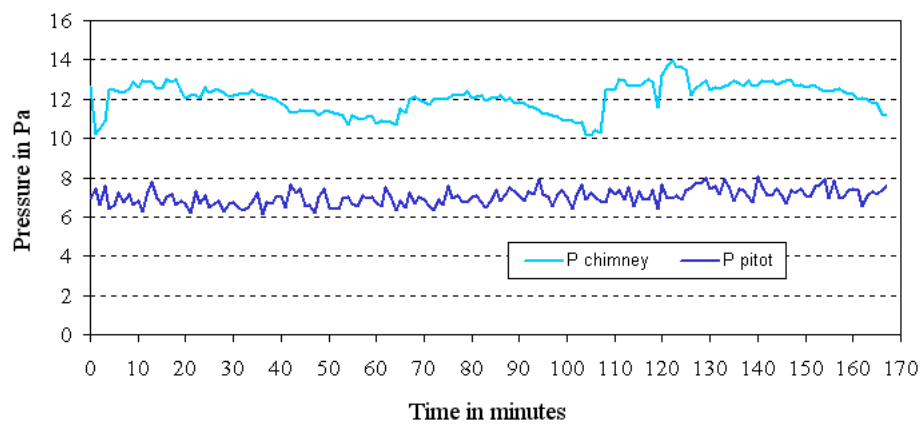

(f)

Figure C.10: Test 39 - Graphs (d)-(f)

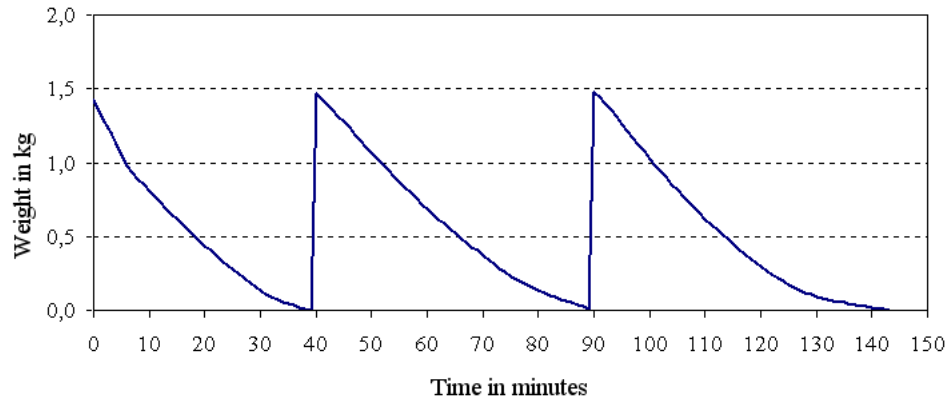

(a)

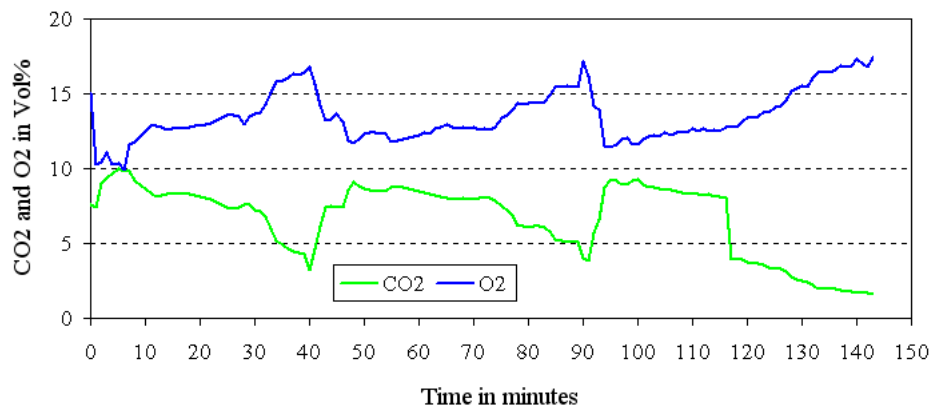

(b)

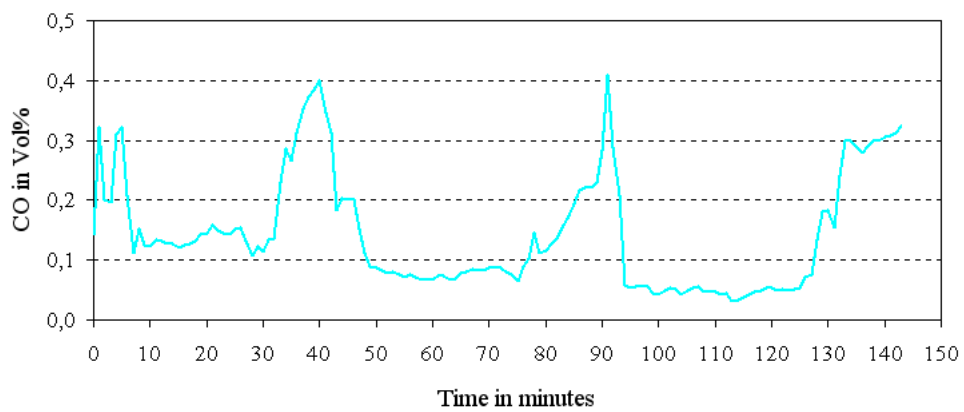

(c)

Figure C.11: Test 40 - Graphs (a)-(c)

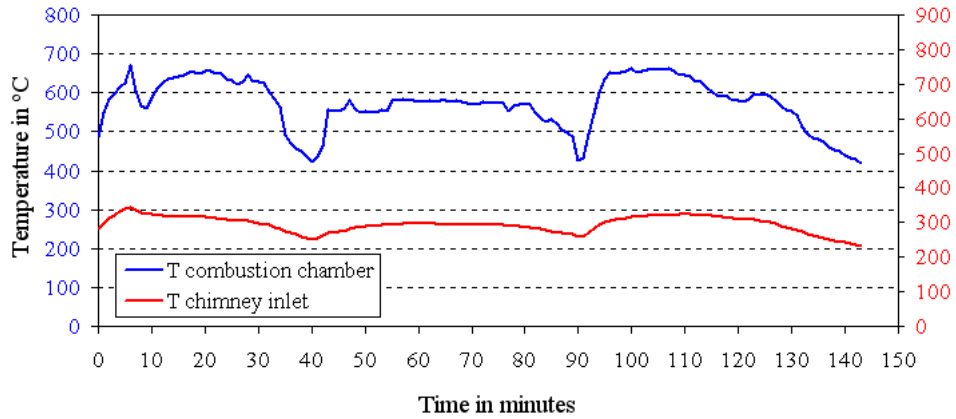

(d)

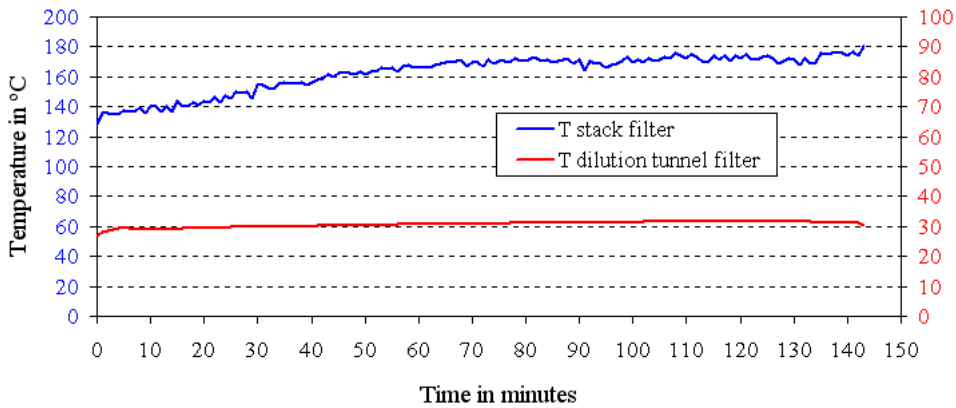

(e)

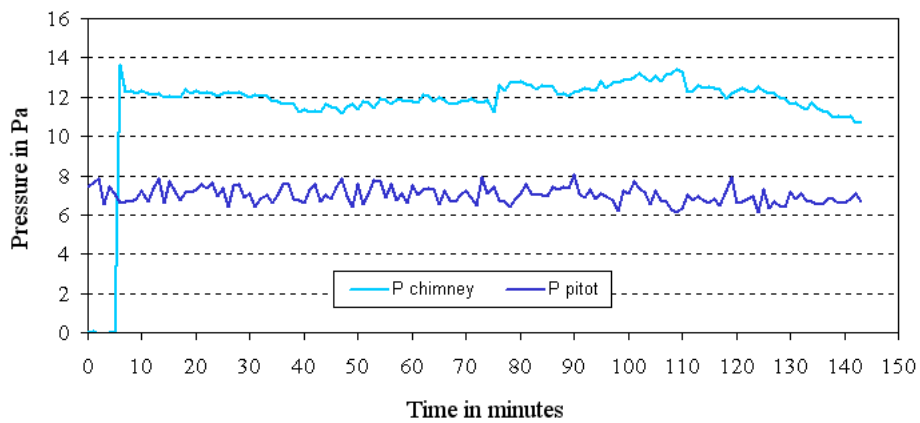

(f)

Figure C.12: Test 40 - Graphs (d)-(f)