

# Innkapslede vakumisolasjonspaneler til bruk i bygninger. -Eksperimentelle bestandighetstester og strategier for rehabilitering

**Elisabeth Gaal Wærnes**

Bygg- og miljøteknikk

Innlevert: juli 2013

Hovedveileder: Bjørn Petter Jelle, BAT

Medveileder: Berit Time, SINTEF Byggforsk

Norges teknisk-naturvitenskapelige universitet  
Institutt for bygg, anlegg og transport



The master thesis is the last compulsory activity required of graduate students at Norwegian University of Science and Technologies (NTNU). The work is delivered under the Department of Civil and Transport Engineering, in close co-operation with SINTEF Building and Infrastructure within the NTNU and SINTEF research project "The Research Centre on Zero Emission Buildings" (ZEB).

The work has been written as two scientific journal articles to be submitted to a relevant scientific journal yet to be decided. Results from accelerated heat aging of encapsulated VIP in laboratory have been the basis for article 1. Article 2 study retrofitting strategies for buildings using VIP. Working with the subjects of accelerated aging and retrofitting strategies in an economic and practical perspective has been both inspirational and instructive. The work has given me a great chance to utilize the technical skills learned throughout my studies at NTNU while at the same time extending my basis for future professional career.

I would like to extend my gratitude to the Department of Building Materials and Structures at SINTEF Building and Infrastructure and my colleagues there. Egil Rognvik deserves a great gratitude for helping me out with the heat flow meter measurements. Special thanks are given to my supervisors Bjørn Petter Jelle and Berit Time at NTNU and SINTEF for helping me throughout this process. Finally, I want to thank my beloved Asle, Håkon and Kari for showing me support and patience in the years as a student.

Trondheim, July 2013

---

Elisabeth Wærnes

## **Norsk sammendrag**

Vakumpaneler gir muligheter for isolering av eksisterende bygningsmasse med tynnere bygningsdeler enn ved bruk av tradisjonelle isolasjonsmaterialer. De er derimot sårbare mot mekanisk slitasje og transmisjon over tid, noe som vil føre til en reduksjon av de termiske egenskapene. Ved å innkapsle panelene i PUR eller EPS, vil de være beskyttet mot den mekaniske slitasjen. En hypotese er at dette også vil kunne forsinke den øvrige aldringen.

Det er utført en eksperimentell studie av aldring av VIP paneler ved hjelp av akselerert aldring over 90 dager. Resultatene viser at dette ikke er tilstrekkelig for å kunne bestemme hvorvidt denne effekten oppstår.

Videre er det gjennomført en analyse av rehabilitering ved hjelp et slikt produkt, hvor energiforbruk, investeringskostnader og mulig forthjeneste er vurdert. På grunn av de høye investeringskostnadene for VIP vil ikke dette kunne svare seg økonomisk alene. Ved å se på alternative rehabiliteringsmetoder og komfort for beboere vil det allikevel kunne svare seg.

## **Contributions**

For this study, all simulations and calculations are performed by Elisabeth Wærnes. The laboratory measurements is performed by Egil Rognvik.

**Article 1**

E. Wærnes, B.P. Jelle and E. Rognvik, "Accelerated Heat Ageing of Encapsulated VIPs"

To be published in a scientific journal in July 2013

---

## Contents

<b>Abstract</b> .....	<b>4</b>
<b>1 Introduction</b> .....	<b>6</b>
<b>2 Theory</b> .....	<b>8</b>
2.1 Vacuum insulation panels (VIP).....	8
2.1.1 Thermal conductivity.....	9
2.1.2 Prediction of ageing effects .....	10
2.2 VIP in compound products .....	15
2.2.1 Polyurethane (PUR).....	15
2.2.2 Expanded polystyrene (EPS).....	15
2.2.3 U-values in inhomogeneous structures.....	15
2.3 Accelerated ageing .....	16
<b>3 Experimental</b> .....	<b>17</b>
3.1 Samples.....	17
3.1.1 Samples VIP .....	17
3.1.2 Samples VIP in PUR .....	18
3.1.3 Samples VIP in EPS .....	19
3.2 Apparatus and methods .....	20
3.2.1 Accelerated ageing method in laboratory .....	20
3.2.2 Heat flow meter .....	20
3.2.3 Accelerated ageing experiments.....	20
<b>4 Results and discussion</b> .....	<b>23</b>
4.1 VIP in PUR.....	23
4.2 VIP in EPS.....	25



4.3 Discussion.....	26
<b>5 Conclusions .....</b>	<b>29</b>
<b>Acknowledgements.....</b>	<b>30</b>
<b>References .....</b>	<b>31</b>

## **Accelerated Heat Ageing of Encapsulated VIPs**

Elisabeth Wærnes<sup>a</sup>, Bjørn Petter Jelle<sup>a,b\*</sup>, Egil Rognvik<sup>b</sup>

<sup>a</sup>Department of Civil and Transport Engineering, Norwegian University of Science and Technology (NTNU), NO-7491 Trondheim, Norway

<sup>b</sup>Department of Materials and Structures, SINTEF Building and Infrastructure, NO-7465 Trondheim, Norway

\* Corresponding author, bjorn.petter.jelle@sintef.no, Phone +47 73 593377

### **Abstract**

Vacuum insulation panels (VIPs) are a high-performance thermal insulation solution, which offer a much higher heat resistance than traditional insulation materials. Thus, is enabling a reduction in thickness of the building envelope, thereby solving one of the major challenges in today's requirements of energy-efficient buildings. Hence, the area efficiency in buildings will increase, and the slimmer walls may lead to increased daylight admission through the window partitions. Furthermore, it gives the possibility of retrofitting existing buildings towards today's standards within acceptable economical and practical measures. Reduction of thermal heat resistance is one of the major challenges when using VIP, thus the degradation of these properties is studied in this article.

An experimental study of ageing effects for VIPs encapsulated in PUR and in EPS has been performed., using methods for accelerated ageing. The time frame of 90 days for the experiments is shown to be too short in order to give a distinctive result on the increase of thermal. Experimental and theoretical results agree within these uncertainties. There has not been shown an advantage of encapsulating VIPs in plastic materials related to the increasing of the thermal conductivity for the panels over time.

Keywords: VIP, vacuum insulation panels, sandwich element, accelerated aging, service life prediction

## 1 Introduction

The requirements of energy efficiency in Norwegian buildings have rapidly increased over the last decades. [1] This is related to matters as international agreements on reducing our energy consumption, electricity shortages and various environmental issues. The general public has motivation factors as increased oil and electric prices and an increased general awareness on the climatic influence connected to our energy consumption.

Given the Norwegian climate, thermal heat loss is normally the largest contributor to the energy consumption in relation to our buildings. The strategy to reduce the heat loss has been to increase the amount of the traditional insulation material in the building envelope, in combination with air tightening measures. This has led to a steadily increase of the recommended wall thickness, and the building authorities have given notice on new requirements in the near future. [2] Using traditional insulation materials, this may require wall thicknesses of 350 – 400 mm to obtain passive house standards, and for Zero emission standards the challenges are even larger.

Increased wall thickness leads to both economical and practical challenges. Small and expensive lots make it important to utilize the area, and the wall thickness is a considerable factor in order to achieve this. Moreover deep window posts reduces the amount of daylight from a given window area. This is in contradiction with the aim to reduce the total window area retaining the heat loss. 80 % of the buildings of 2050 are already built. [3] This shows the need for renovation strategies for existing buildings to meet today's standards regarding energy efficiency. Reducing the heat loss for these buildings by adding insulation may be in conflict with the existing architecture and construction techniques. [4]

To address these challenges, the development of more effective insulation materials and solutions has been given great attention. Vacuum insulation panels (VIP) are one of the most interesting products in this context. The panels consist of a fumed silica core with micro pores, enclosed with an internal vacuum in a multi layered foil. This solution gives a considerable better thermal heat resistance than traditional insulation materials.

The main prerequisite of the VIPs is that the internal vacuum must be intact for the panels to maintain their thermal qualities. [5] Possibilities for protecting the VIPs against these risks have been discussed. The major factor to the service life for VIPs is air and water vapour diffusion through the envelope foil. [6] [7] One solution could be to encapsulate the panels in other materials. This might eliminate the mechanical stress on the envelope. A question is whether this also could affect the aging of the panels due to diffusion. Models for service life prediction has been suggested by Schwab et al. [6] [7] and Tenpierik. [8]

This work will investigate experimentally whether the capsulation of vacuum insulation panels (VIP) in plastic materials will detain the gas and water transmission through the foil envelope, expanding the functional lifetime of the panels.

Two design models of products have been developed with the aim to obtain these effects. The first product is a light weight aggregated concrete sandwich wall block with VIP encapsulated in PUR (VIP in PUR). The second product is a floor sandwich element with VIP encapsulated in EPS (VIP in EPS). For the VIP in PUR, the manufacturing process will lead to a higher PUR density as a skin at the outer surface, which may further constrict the diffusion of PUR gases, air and moisture.



*Fig.1 Light-weight aggregated concrete sandwich block with VIP encapsulated in PUR*

To make this study possible, the products have been exposed to an accelerated aging process. The initial and final thermal conductivity was then measured. A model has been used to theoretically estimate the degradation of the products, where a comparison with the experimental results is presented.

## 2 Theory

### 2.1 Vacuum insulation panels (VIP)

Vacuum insulation panels are high performance thermal insulation products for building applications[9]. The panels consist of a porous fumed silica core enclosed in a foil envelope.

An internal vacuum is applied during the manufacture. The core has an open cell structure, enabling the air to evacuate the core material in this process. The foil envelope is designed to detain air-, water vapour- and water diffusion in to the core. The built-up of the envelope can vary, but commonly consist of multiple layers of Aluminium and polymers. For a description

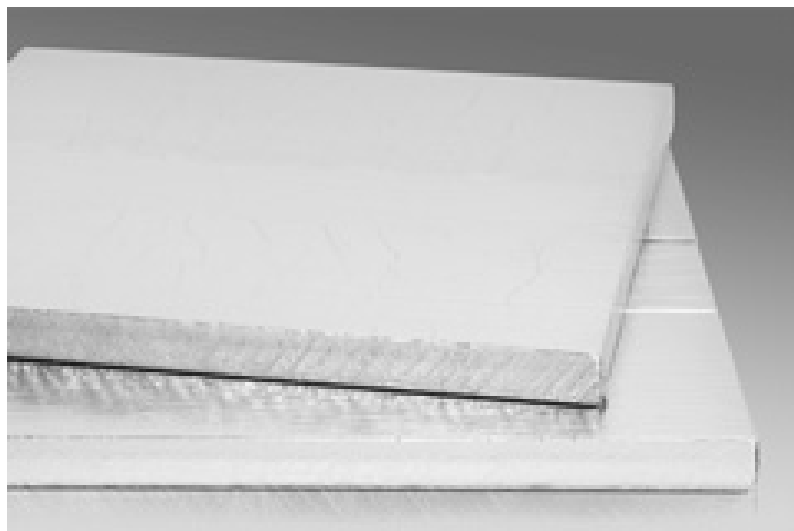

*Fig.2 Vacuum insulation panels (Porextherm 2012)*

of the different envelope solutions in use today, see Wegger et al. [10].

The high thermal resistance of the panels is dependent on the internal vacuum pressure. This makes them vulnerable to puncture due to wear, especially on the edges and corners, and cuts during installation. Air, water vapour and water will diffuse through the foil envelope over time. After several decades the core will be in equilibrium with the surroundings. At this time the panels will have lost 80 % of their thermal heat resistance. The thermal properties of the panels would still be considerably better than for traditional insulation materials, but considering the reduced insulation thickness they will now not fulfil the desired requirements.

*The methods in the following sections have been applied to the VIPs studied in this work. The results of these calculations are presented in section*

4.3 Discussion as a comparative to the experimental studies of the panels and the degradation of their thermal properties.

### **2.1.1 Thermal conductivity**

To estimate the thermal conductivity of the vacuum insulation panels, theoretical models where this is accounted for has been applied [9]. The thermal conductivity of the VIP may be separated into the contributions of the heat transport through the material and may be written as [11]:

$$\lambda_{tot} = \lambda_{con} + \lambda_{gas} + \lambda_{rad} + \lambda_{conv} + \lambda_{coup} \quad (1)$$

where  $\lambda_{con}$  the conduction through the solid material,  $\lambda_{gas}$  the conduction within the encapsulated gas,  $\lambda_{rad}$  is the radiation heat transfer, and  $\lambda_{conv}$  the gas convection.  $\lambda_{coup}$  is due to a coupling effect in the material fibres. The coupling effect is neglected in the further work

due to its complexity. The main reduction to  $\lambda_{tot}$  in the panel is due to the reduction of the  $\lambda_{gas}$ . Water content will affect both  $\lambda_{con}$  as liquid water and  $\lambda_{gas}$  as water vapour.

Thermal bridges effects arise due to the high thermal conductivity of the foil envelop. This effect is described as[5]:

$$\lambda_{eff} = \lambda_{cop} + \psi_{VIP} \frac{dP}{A} \quad (2)$$

where  $\lambda_{cop}$  represent the initial thermal conductivity of the panel and  $\psi_{VIP}$  is the linear thermal transmittance of the VIP edge.

### 2.1.2 Prediction of ageing effects

Theoretical models have been developed to estimate the change in thermal conductivity for vacuum insulation panels over time. These changes occur due to gas and water transport through the envelope foil. For these models,  $\lambda_{con}$  is independent of the change in air and water pressure. The same applies to the radiation heat transfer  $\lambda_{rad}$ .

The change in gas pressure is

$$\frac{dp_g}{dt} = \frac{Q_{g,tot} \Delta p_{g,e}}{V_{eff}} \left( \frac{T_m p_0}{T_0} \right) \quad (3)$$

where  $p_g$  can be written as



$$p_g = p_{g,e} - (p_{g,e} - p_{g,t=0})e^{(-Q_{g,tot}/V_{eff})(T_m p_0/T_0)t} \quad (4)$$

The change in water vapour pressure can be written as

$$\frac{dX_w}{dt} = \frac{Q_{wv,tot}\Delta p_{g,e}}{m_{vip,dry}} p_{wv,sat}(T) [\varphi_{wv,out} - \varphi_{wv,in}(X)] \quad (5)$$

where  $X_w$  can be written as

$$X_w(t) = k\varphi_{wv,out} \left(1 - e^{(-Q_{wv,tot}p_{wv,sat}(T)/m_{vip,dry}k)t}\right) \quad (6)$$

The change in heat conductivity due to the aging of the panels may be seen as the collective change in heat conductivity from three changes in environmental properties [9],

$$\Delta\lambda_c(t) = \frac{\partial\lambda_c}{\partial p_g} \Delta p_g(t) + \frac{\partial\lambda_c}{\partial p_{wv}} \Delta p_{wv}(t) + \frac{\partial\lambda_c}{\partial u} \Delta u(t) \quad (7)$$

with

$$\Delta p_g(t) = p_{g,e} \left( 1 - \exp\left(-\frac{t - t_{get}}{\tau_g}\right) \right) \quad (8)$$

$$\Delta p_{wv}(t) = p_{wv,e} \left( 1 - \exp\left(-\frac{t - t_{des}}{\tau_w}\right) \right) \quad (9)$$

$$\Delta u(t) = \frac{\partial u}{\partial \varphi} \varphi_e \left( 1 - \exp\left(-\frac{t - t_{des}}{\tau_w}\right) \right) \quad (10)$$

where  $\Delta p_g(t)$  is the change in pressure due to air diffusion;  $\Delta p_{wv}(t)$  is the change in water pressure in the VIP core and  $\Delta u(t)$  the change in liquid water content in the core due to diffusion. The total change over time for each contribution depended on the saturation limit for gas, water and water vapour, and the time-constants  $\tau_g$  and  $\tau_w$  for the gas and water transport through the envelope.  $\tau_g$  and  $\tau_w$  represent the time constants dependent of the temperature and RH, defined as the analytical model for service life of Tenpierik et al. [8]

$$\tau_g = \frac{\varepsilon V}{GTR(T, \varphi)} \frac{\Delta p_g T_0}{p_0 T} \quad (11)$$

and

$$\tau_w = \frac{\rho_{dry} V}{WVTR(T, \varphi)} \frac{\Delta p_w 1}{p_{sat}(T)} \frac{du}{d\varphi} \quad (12)$$

The time constants  $\tau_g$  and  $\tau_w$  are determined by the diffusion constants  $GTR(T, \varphi)$  and  $WVTR(T, \varphi)$  for the gas and water, and by geometric and environmental parameters. The change in  $\lambda$  dependent of time is then given by the following [10]:

$$\lambda_g(t) = \frac{\lambda_{g,0}}{1 + p_{\frac{1}{2},g}/p_g(t)} \quad (13)$$

$$\lambda_w(t) = \frac{\partial \lambda_c}{\partial u} \frac{\partial u}{\partial \varphi} \varphi_e \left( 1 - \exp\left(-\frac{t - t_{des}}{\tau_w}\right) \right) \quad (14)$$

$$\lambda_{wv}(t) = \frac{\lambda_{wv0}}{1 + p_{\frac{1}{2},wv}/p_{wv}(t)} \quad (15)$$

where

$$p_{wv}(t) = p_{wv,e} \left( 1 - \exp\left(-\frac{t}{\tau_w}\right) \right) \quad (16)$$

$$p_g(t) = p_{g,e} \left( 1 - \exp\left(-\frac{t}{\tau_g}\right) \right) \quad (17)$$

For the calculations in section 4.3, the values from Table 1 been applied. The properties is according to Wegger et al. [10]

*Table 1 Properties for theoretical calculations*

<b>Properties</b>			
<b>ATR<sub>A</sub></b>	0,0088	2,00E-09	cm <sup>3</sup> /(m <sup>2</sup> d)
<b>ATR<sub>L</sub></b>	0,0018	3,00E-10	cm <sup>3</sup> /(md)
<b>WVTR<sub>A</sub></b>	0,0048	0,0004	g/(m <sup>2</sup> d)
<b>ε</b>	0,9		
<b>ρ<sub>dry</sub></b>	2,00E+05		kg/m <sup>3</sup>
<b>p<sub>sat</sub></b>	2775		Pa
<b>du/dφ</b>	0,08		
<b>δλ<sub>c</sub>/δu</b>	0,00029		mW/(mK)
<b>RHφ</b>	0,5		
<b>λ<sub>wv,0</sub></b>	0,016		mW/(mK)
<b>p<sub>1/2,wv</sub></b>	12000		Pa
<b>λ<sub>air,0</sub></b>	0,0257		mW/(mK)
<b>p<sub>1/2,air</sub></b>	59300		Pa
<b>φ<sub>e</sub></b>	0,06		

## **2.2 VIP in compound products**

### **2.2.1 Polyurethane (PUR)**

PUR as a rigid foam insulation material consist of polyurethane mixed with a blowing agent. The thermal properties of the gas used, often a variant of hydrocarbon pentane, determine the thermal resistance of the PUR, with typical thermal conductivity  $\lambda=0.024$  W/(mK). Due to the closed cell structure, the gas will maintain in the material for a long time. The thermal conductivity of PUR is therefore only slightly influenced by aging. PUR does not absorb water from the surrounding air. The water vapour resistance factor  $\mu$  will vary according to the manufacturing process and the density of the material. If the product has a surface skin, the water vapour resistance will increase.

### **2.2.2 Expanded polystyrene (EPS)**

Expanded polystyrene (EPS) is an insulation material consisting of 98 % air and 2 % polystyrene. It has a typical thermal conductivity  $\lambda=0.035$  W/(mK). With a closed cell structure, its thermal conductivity is only slightly influenced by ageing.

### **2.2.3 U-values in inhomogeneous structures**

Two models can be obtained to calculate the U-value in inhomogeneous structures. The  $\lambda$ -model is given by

$$R_{T\theta} = \frac{\sum A}{\sum \left(\frac{A}{R_T}\right)} \quad (18)$$

where A= the area for one field, and  $R_T$  = the total thermal resistance through air for one field. This model overestimates the U-value. The U-value model is given by

$$R_{T\theta} = R_i + \Sigma R_x + R_e \quad (19)$$

where

$$R_x = \frac{\Sigma A}{\Sigma \left(\frac{A}{R}\right)} \quad (20)$$

$R_i$  = the internal thermal resistance,  $R_x$  = the thermal resistance for a material through several layers,  $R_e$  = external thermal resistance,  $R$  = the thermal resistance for a homogeneous layer in a field and  $A$  = the area of a field. This model underestimates the U-value.

### 2.3 Accelerated ageing

Climatic exposure factors on building materials and products are presented by Jelle [12]. These are factors which will define the probable aging process of a material. Identifying these aging factors on installed materials and products can be challenging. It is difficult to quantify the applied exposures and to separate the different factors from each other. In order to determine the expected service life of a material or product, we need to examine the specimens according to reproducible conditions. Various test methods for different building materials and products have been developed in order to form a foundation for service life prediction. [13]

Effects due to aging are in particular difficult to study within reasonable time and economic measures. For VIPs, aging effects are caused by air and water diffusion through the foil envelope. Accelerated aging in a laboratory can be achieved by exposing a material to an elevated temperature. The air and water diffusion rate through the envelope foil is proportional to the air and water collision rate with the foil, and may be accelerated by an

increase in temperature. Though, there are at present no standardized model for VIPs, CUAP 12.01/30 [14] suggests an experimental model for accelerated heat aging.

The predicted theoretical ageing effects of the thermal conductivity for VIPs is shown in Figure 3. [9]

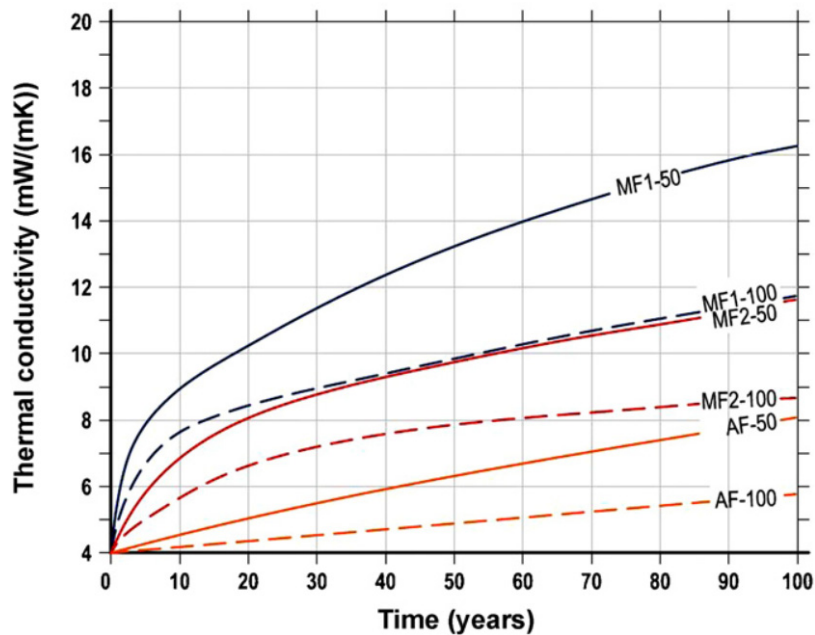

Figure 3 Center of panel thermal conductivity for VIPs, Baetens et al. 2010

### 3 Experimental

#### 3.1 Samples

##### 3.1.1 Samples VIP

The VIPs used in this study is Vacupor NT-B2-S from Porextherm, [15] The panels used in product 1, the VIP in PUR are 480 x 230 x 50 mm. The panels used in product 2, the VIP in EPS are 580 x 280 x 30 mm. The panels have a triple metal layered foil envelope, comparable to envelope MF4 from Wegger et al.[10]. The panels used in the products are also aged alone in order to compare whether the encapsulation is affecting the aging process.

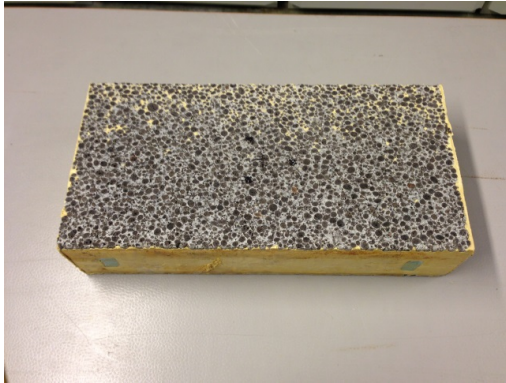

*Fig.4 VIP panel Vacupor NT-B''-S from Porextherm, used in this study*

### **3.1.2 Samples VIP in PUR**

The light-weight aggregated concrete sandwich wall block has VIP encapsulated in PUR. The dimension is 500 x 250 x 250 mm. For this study, the light-weight aggregated concrete was cut to allow the system to achieve steady state within a shorter time. The adjusted dimensions are 500 x 250 x 108 mm. Figure 5 and 6 shows the specimens as used in the study.





*Fig.5 VIP in PUR*



*Fig.6 VIP in PUR*

### **3.1.3 Samples VIP in EPS**

Comfort Floor element with VIP encapsulated in EPS consist of a VIP in a thin layer of EPS. The dimension is 600 x 300 x 70 mm. For this study, the element tops was cut to allow a smooth surface for the heat flow meter measurements. The adjusted dimensions are 500 x 250 x 51 mm. Fig.7 show the specimens as used in the study.

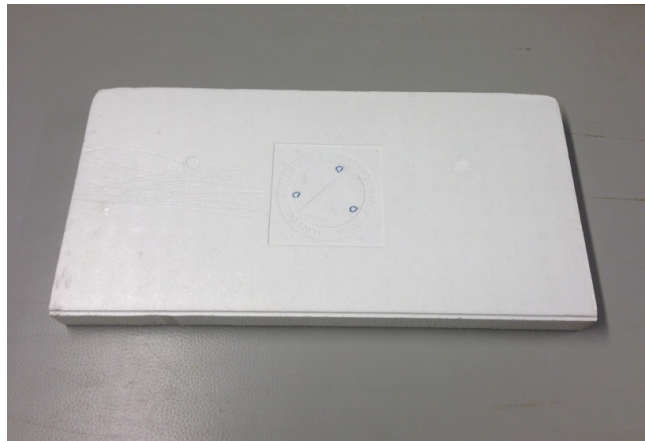

*Fig.7 VIP in EPS adjusted*

## **3.2 Apparatus and methods**

### **3.2.1 Accelerated ageing method in laboratory**

The CUAP 1201/30 suggests a method for accelerated heat aging of VIPs involving exposing the VIPs to 80°C for 180 days, aging the panel's equivalent to 25 years. At this temperature, polymer materials as PUR and EPS will be exposed to strains not present at natural aging. In order to prevent the specimens to degrade in any other way, the experimental study in this paper has used the methods for accelerated aging described in EN 13165 Annex C [16].

### **3.2.2 Heat flow meter**

The measurements in this study are performed using a heat flow meter, and are performed in according to ISO 8301 and NS-EN 12667.



*Fig.8 Heat flow meter apparatus*

### **3.2.3 Accelerated ageing experiments**

The scope and the test set up for the two products are as described in this section and in table 2 and table 3.

Scope 1: Evaluate how aging affects the air and water vapour transport through the PUR and the VIP envelope.

*Table 2 Test specimens for VIP in PUR*

<b>Specimen</b>	<b>Type</b>	<b>Exposure</b>
<b>T1</b>	VIP in PUR	EN 13165
<b>T2</b>	VIP in PUR	EN 13165
<b>T3</b>	VIP in PUR	EN 13165
<b>T4</b>	VIP in PUR	EN 13165
<b>T5</b>	VIP in PUR	Non-aged
<b>T6</b>	VIP in PUR	Non-aged
<b>V1</b>	VIP	EN 13165
<b>V2</b>	VIP	EN 13165
<b>V3</b>	VIP	Non-aged

Scope 2: Evaluate how aging affects the air and water vapour transport through the EPS and the VIP envelope.

*Table 3 Test specimens for VIP in EPS*

<b>Specimen</b>	<b>Type</b>	<b>Exposure</b>
<b>E1</b>	VIP in EPS	EN 13165
<b>E2</b>	VIP in EPS	EN 13165
<b>E3</b>	VIP in EPS	EN 13165
<b>E4</b>	VIP in EPS	Non-aged
<b>E5</b>	VIP in EPS	Non-aged
<b>G1</b>	VIP	EN 13165
<b>G2</b>	VIP	EN 13165
<b>G3</b>	VIP	Non-aged

Procedure:

- Conditioning at 22°C, 50% RH for at least 72 h.
- Measuring initial thermal conductivity
- Heat aging for 90 days at 70°C
- Heat conductivity is measured after 0, 30 and 90 days

## 4 Results and discussion

### 4.1 VIP in PUR

The measured reference thermal conductivity is presented in Fig.9. T1-T4 are exposed to ageing, while T5-T6 are reference. V1-V2 are exposed to ageing, and V3 is reference. The uncertainties in the measurements are visualized by intervals for each measured value. Change in thermal conductivity is presented in Fig.10 and close up in Fig.11.

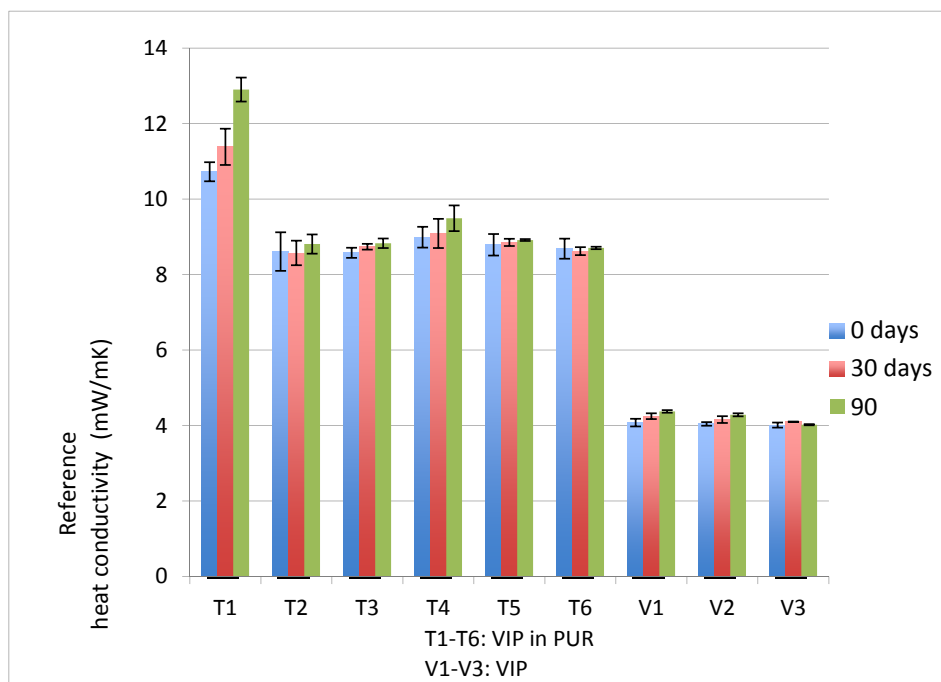

*Fig.9 Thermal conductivity of VIP in PUR. T1-T4 are aged T5-T6 are reference. V1-V2 are aged, V3 is reference*

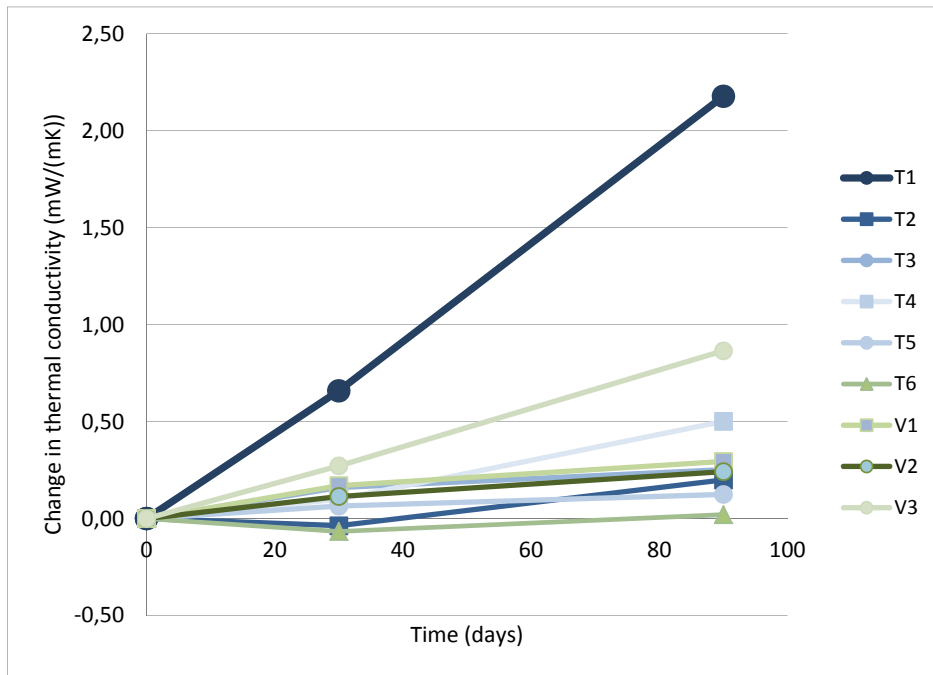

Fig.10 Change in thermal conductivity of VIP in PUR

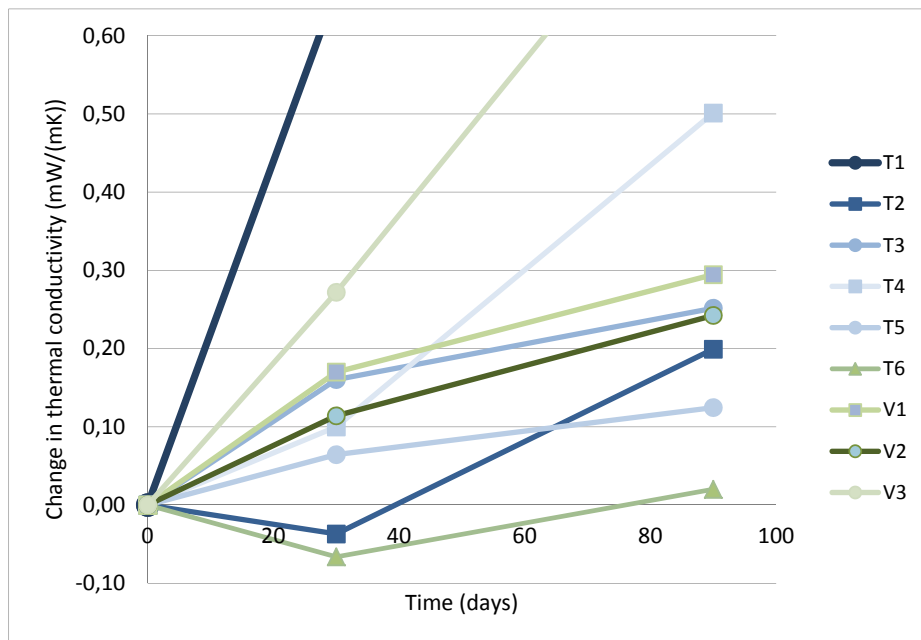

Fig.11 Change in thermal conductivity of VIP in PUR, zoom in from figure 9

## 4.2 VIP in EPS

The measured reference thermal conductivity is presented in Fig.12. E1-E3 are exposed to aging, while E4-E5 are reference. G1-G2 are exposed to aging, and G3 is reference. The uncertainties in the measurements are visualized by intervals for each measured value. Change in thermal conductivity is presented in Fig.13.

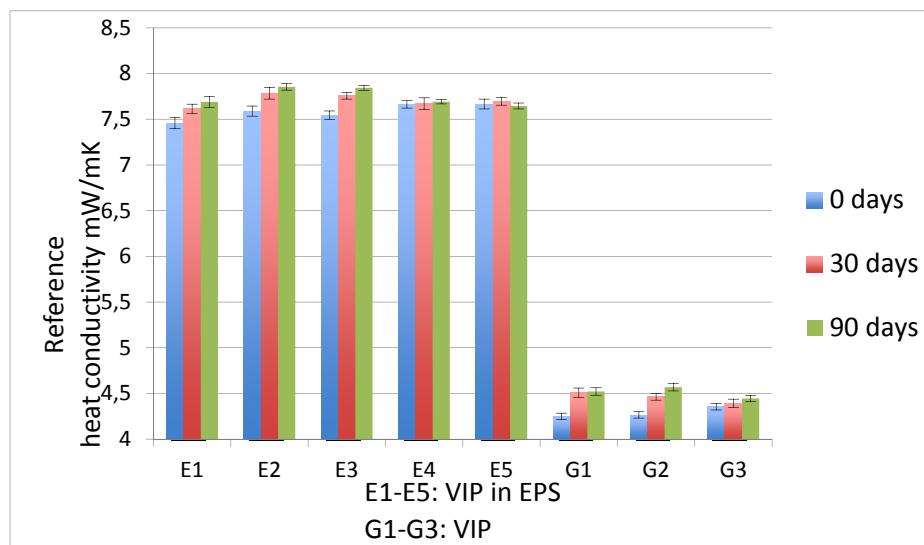

Fig.12 Thermal conductivity of VIP in EPS

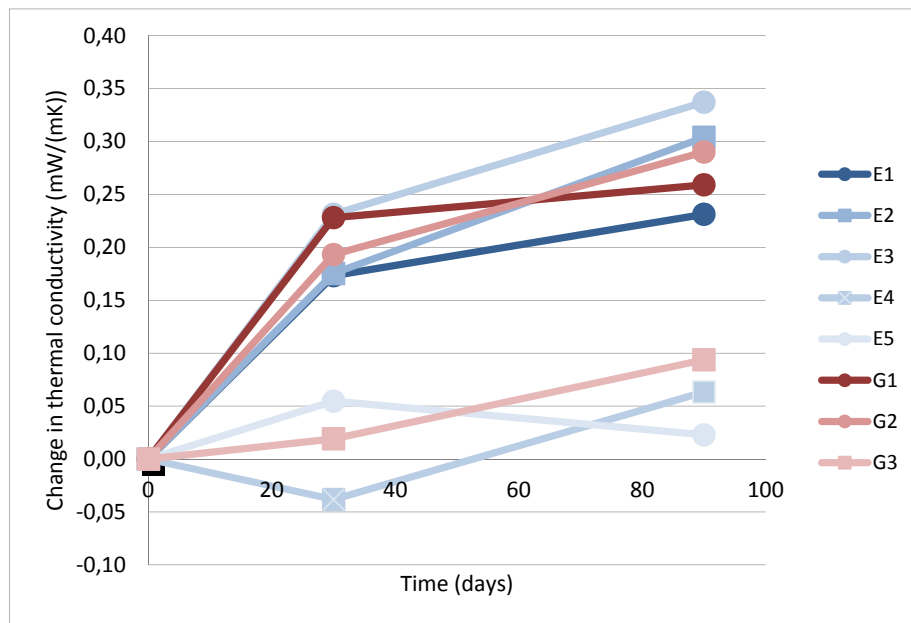

Fig.13 Change in thermal conductivity of VIP in EPS

### 4.3 Discussion

In order to compare the measured results with the theoretical estimated aging, the expected development in thermal conductivity has been calculated as described in section 2.1.2. Table 4 presents the calculated and experimental U-values for the VIPs, the VIP in PUR system and the VIP in EPS system, both the initial values and the aged values. Fig.14 presents the predicted aging curve for the VIPs compared with the measured values.



*Table 4 Comparison of calculated and measured average U-values for VIPs, VIP in PUR and VIP in EPS*

U-values	Initial	Aged 90 days
	mW/(m <sup>2</sup> K)	W/(m <sup>2</sup> K)
VIP 1 calculated (used in PUR)	0.080	0.094
VIP 1 experimental (used in PUR)	0.081±0.001	0.087±0.001
VIP 2 calculated (used in EPS)	0.080	0.094
VIP 2 experimental (used in EPS)	0.084±0.001	0.089±0.001
VIP in PUR calculated	0.085	0.106
VIP in PUR experimental	0.058±0.002	0.063±0.004
VIP in EPS calculated	0.184	0.206
VIP in EPS experimental	0.145±0.001	0.151±0.001

The measurements show that the thermal conductivity for the VIPs have not been increased substantially over the 90 days ageing period. This applies for both the encapsulated and non-encapsulated panels. One may observe an increase in the thermal conductivity for all panels. For the VIP in EPS panels there is a clear difference in change in thermal conductivity between the panels that has been exposed to accelerated heat ageing and the reference panels. This is not the case for the VIP in PUR panels, where the change in thermal conductivity appeared more random.

For both systems, there is no evident reduction in change in the thermal conductivity for the panels encapsulated in plastic. Hence, one cannot state based on this study that this solution would increase the protection of the panels in relation to gas and water transmission through the envelope foil. A theoretical prediction of this effect has not been addressed.

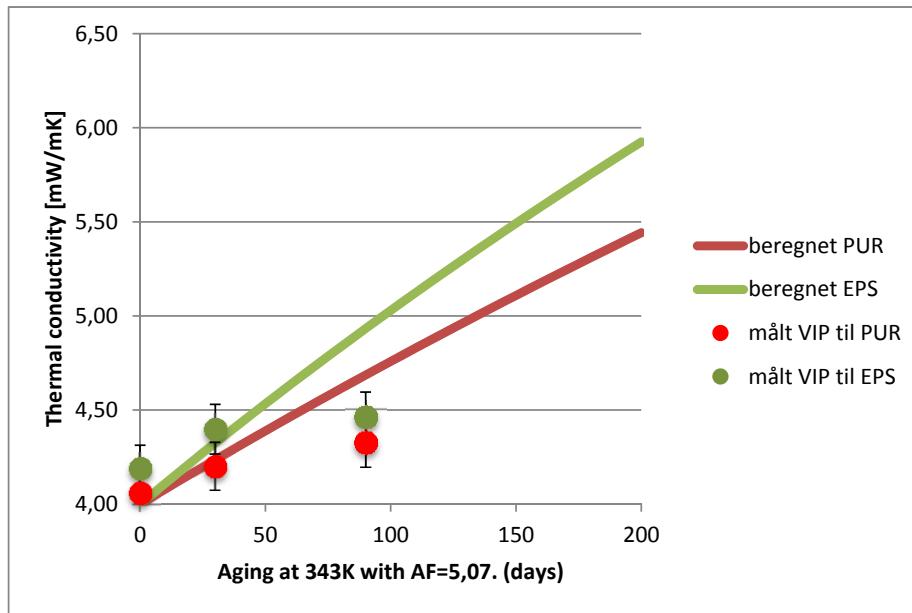

Fig.14 Calculated thermal conductivity for the panels compared to measured values (180 days = 25 years)

From Figure 14, the experimental results are in agreement with the theoretical predictions. However, the experimental increase is relatively small compared with the uncertainties in the experiments. Furthermore, the predicted ageing effects of the panels are greatly sensitive to the activation energy specific for the envelope foil.

These studies have been performed over a relatively short ageing period of time. The accelerated ageing experiments for the panels are not comparable to the desired service life for VIPs. A more accurate estimate of future thermal conductivity is expected when applying the ageing method for at least 180 days. This was not possible within the time frame of this master thesis.

Accelerated ageing of building materials is a unique method for evaluating their properties sensitive to ageing. By avoiding field experiments and observing the properties during the estimated service life, the method could save both time and money. However, the conditions used in the experiments are extreme compared to the real expected conditions that the product must withstand. Uncontrollable high temperature effects may occur, such that the experiment does not represent to the real conditions.

## **5 Conclusions**

An experimental study of ageing effects for VIPs encapsulated in PUR and in EPS has been performed. The time frame of 90 days for the experiments is shown to be too short in order to give a distinctive result on the increase of thermal conductivity. It is expected to get more reliable results when the experiments have lasted 180 days. Uncertainties related to the heat flow meter measurements are significant, making the measured difference in thermal conductivity difficult to interpret. Experimental and theoretical results agree within these uncertainties.

There has not been shown an advantage of encapsulating VIPs in plastic materials related to the increasing of the thermal conductivity for the panels over time.

## **Acknowledgements**

This report has been written within the *Research Centre on Zero Emission Buildings* (ZEB). The authors gratefully acknowledge the support from the Research Council of Norway, BNL – Federation of construction industries, Brødrene Dahl, ByBo, DiBK – Norwegian Building Authority, DuPont, Enova SF, Entra, Forsvarsbygg, Glava, Husbanken, Hydro Aluminium, Isola, Multiconsult, NorDan, Norsk Teknologi, Protan, Skanska, Snøhetta, Statsbygg, VELUX, Weber and YIT.

## References

1. Sandberg, N.H., H. Bergsdal, and H. Brattebø, *Historical energy analysis of the Norwegian dwelling stock*. Building Research & Information, 2011. **39**(1): p. 1-15.
2. regionaldepartementet, K.-o., *Energieffektive passivhus kan bli standard raskere*. 2010.
3. Dixon, T., *Sustainable Urban Development to 2050: Complex Transitions in the Built Environment of Cities*. WP2011/5 October, 2011.
4. Sartori, I., B.J. Wachenfeldt, and A.G. Hestnes, *Energy demand in the Norwegian building stock: Scenarios on potential reduction*. Energy Policy, 2009. **37**(5): p. 1614-1627.
5. Simmler, H. and S. Brunner, *Vacuum insulation panels for building application Basic properties, aging mechanisms and service life*. Energy and Buildings, 2005. **37**(11): p. 1122-1131.
6. Schwab, H., et al., *Prediction of service life for vacuum insulation panels with fumed silica kernel and foil cover*. Journal of thermal envelope and building science, 2005. **28**(4): p. 357-374.
7. Schwab, H., et al., *Permeation of different gases through foils used as envelopes for vacuum insulation panels*. Journal of thermal envelope and building science, 2005. **28**(4): p. 293-317.
8. Tenpierik, M.J., van der Spoel W and Cauberg H, *Simplified analytical models for service life prediction of a vacuum insulation panel.*, in *Proceedings of the 8th International Vacuum Insulation Symposium*, A. Beck, et al., Editor. 2007: ZAE Bayern/UniWue, Würzburg, 18-19 September.
9. Baetens, R., et al., *Vacuum insulation panels for building applications: A review and beyond*. Energy and Buildings, 2010. **42**(2): p. 147-172.
10. Wegger, E., et al., *Aging effects on thermal properties and service life of vacuum insulation panels*. Journal of Building Physics, 2011. **35**(2): p. 128-167.
11. Brodt, K.H., *Thermal insulations: cfc-alternatives and vacuum insulation*. 1995.
12. Jelle, B.P., *Accelerated climate ageing of building materials, components and structures in the laboratory*. Journal of Materials Science, 2012. **47**(18): p. 6475-6496.

13. Daniotti, B. and F.R. Cecconi. *CIB W080: test methods for service life prediction*. in *CIB Publication*. 2010.
14. (2009), C., *Factory made vacuum insulation panels*. August 2009.
15. DIBt, *General Technical Approval number Z -23.11-1662*.
16. *EN 13165 Annex C*.

## **Article 2**

E. Wærnes and B.P. Jelle "Retrofitting Strategies for Buildings with Encapsulated VIPs – A Model Study of Possible Applications"





## Table of Contents

Abstract .....	4
1 Introduction .....	5
2 Experimental .....	7
2.1 Case .....	7
2.1.1 Product .....	7
2.1.2 Model building.....	8
2.2 Implementation.....	9
2.2.1 Floor concept VIP in EPS .....	9
2.2.2 Floor concept VIP .....	10
2.2.3 Building restrictions.....	10
2.3 Simulation tools.....	10
2.3.1 SIMIEN .....	10
2.3.2 THERM.....	11
3 Results .....	11
3.1 SIMIEN .....	11
3.2 THERM .....	12
3.3 Economic impact .....	15
3.4 Environmental impact.....	17
4 Discussion .....	17
5 Conclusion.....	20
Acknowledgements .....	21
References .....	22



## **Retrofitting Strategies for Buildings with Encapsulated VIPs – A Model Study of Possible Applications**

Elisabeth Wærnes<sup>a</sup>, Bjørn Petter Jelle<sup>a,b\*</sup>

<sup>a</sup> Department of Civil and Transport Engineering, Norwegian University of Science and Technology (NTNU), NO-7491 Trondheim, Norway

<sup>b</sup> Department of Materials and Structures, SINTEF Building and Infrastructure, NO-7465 Trondheim, Norway

\* Corresponding author, [bjorn.petter.jelle@sintef.no](mailto:bjorn.petter.jelle@sintef.no), Phone +47 73 593377

### **Abstract**

Vacuum insulation panels are one of the most interesting solutions today addressing the challenges connected to retrofitting due to energy requirements. Concepts for retrofitting buildings using EPS elements with encapsulated VIPs are studied. Economic and environmental issues are addressed related to energy prices, CO<sub>2</sub>–emissions and investments costs.

SIMIEN and THERM has been used for the analysis, covering both the effects on the building as a whole and details as thermal bridges.

The high production costs for the VIPs make this solution not favorable in economic terms. Change in production costs or electricity prices could make this more profitable. Other advantages must be taken in to account in order to justify the investment costs within today's situation. Simpler installation compared with alternative solutions and indoor climatic comfort are properties that could affect the foundation.

## 1 Introduction

The building sector is responsible for 40% of the total energy consumption. [1] The requirements of energy efficiency in Norwegian buildings have rapidly increased over the last decades. [2] This is related to matters as international agreements on reducing our energy consumption, electricity shortages and various environmental issues. The general public has motivation factors as increased oil and electric prices and an increased general awareness on the climatic influence connected to our energy consumption.

Given the Norwegian climate, thermal heat loss is the largest contributor to the energy consumption in relation to our buildings. The strategy to reduce the heat loss has been to increase the amount of the traditional insulation material in the building envelope, in combination with air tightening measures. This has led to a steadily increase of the recommended thickness of insulation in the building envelope. 80 % of the buildings of 2050 are already built. [3] This shows the need for renovation strategies for existing buildings to meet today's standards regarding energy efficiency. Reducing the heat loss for these buildings by adding insulation may be in conflict with the existing architecture and construction techniques. [4]

Floors are in particular difficult to renovate. Adding insulation over the existing structure will reduce the ceiling height. Using traditional insulation, this would be in conflict with the required internal height for spaces used for living purpose. This leaves two options, increasing the internal ceiling height by raising the roof or adding insulation below the original floor. Both solutions can be technical challenging and expensive compared with the economic benefits of the given reduction in heat loss. This calls for innovative solutions which comply with both the economic and technical issues.

To address these challenges, the development of more effective insulation materials and solutions has been given great attention. Vacuum Insulation Panels (VIPs) is one of the most interesting products in this context. The panels consist of a fumed silica core with micro pores, enclosed with an internal vacuum in a multi layered foil. This solution gives a considerable better thermal heat resistance than traditional insulation materials.

The main prerequisite of the VIPs is that the internal vacuum must be intact for the panels to maintain their thermal qualities. [5] Possibilities for protecting the VIPs against these risks have been discussed. The major factor to the service life for VIPs is air and water vapour

diffusion through the envelope foil. [6] [7] One solution could be to encapsulate the panels in plastic materials. This could eliminate the mechanical stress on the envelope.

This work investigates the possibilities and potential benefits of retrofitting existing buildings using encapsulated VIPs regarding practical and economic measures, increasing the energy efficiency.

A design model of a floor system element has been developed with the aim to obtain these effects. The product consists of elements with VIP encapsulated in EPS. (VIP in EPS) This study evaluates the estimated energy saving potential, when the product is installed in a typical Norwegian wooden, single family dwelling from 1960. SIMIEN simulations are carried out using a model building, making an energy demand evaluation possible. Economic and environmental impact given by the estimated saving potential and predicted service life of VIPs is evaluated. THERM is used to evaluate thermal bridges. Finally, a sensitivity analysis is applied to investigate effects from changes in the economic conditions.

## 2 Experimental

### 2.1 Case

#### 2.1.1 Product

Vacuum insulation panels are high performance thermal insulation products for building applications[8]. The panels consist of a porous fumed silica core enclosed in a foil envelope. An internal vacuum is applied during the manufacture. The core has an open cell structure, enabling the air to evacuate the core material in this process. The foil envelope is designed to detain air-, water vapour- and water diffusion in to the core.[9].

The high thermal resistance of the panels is dependent on the internal vacuum pressure. This makes them vulnerable to puncture due to wear, especially on the edges and corners, and cuts during installation. On-site adjustments of the panels is not possible, thus a complete filling of an area will not be possible without special orders or designing the building based on typical VIP dimensions. Air, water vapour and water will diffuse through the foil envelope over time. After several decades the core will be in equilibrium with the surroundings. At this time the panels will have lost 80 % of their thermal heat resistance. [8] The thermal properties of the panels would still be considerably better than for traditional insulation materials, but considering the reduced insulation thickness they will now not fulfil the desired requirements.

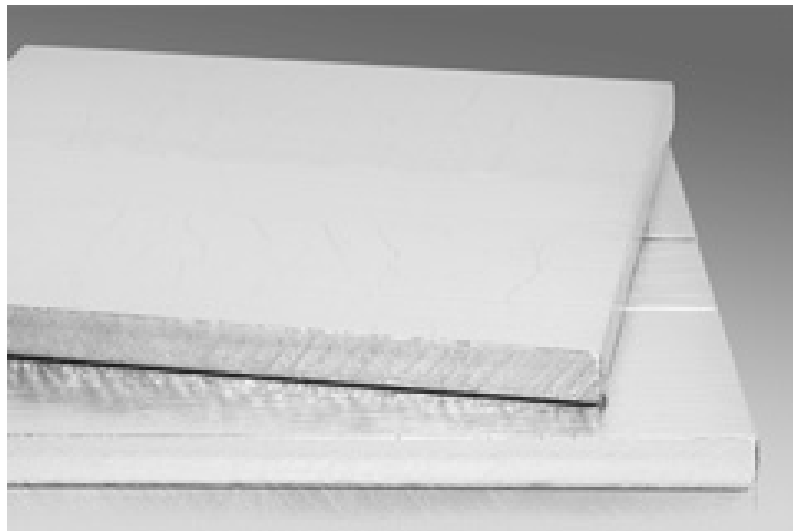

*Fig.1 Vacuum insulation panels (Porextherm 2012)*

Comfort Floor element with VIP encapsulated in EPS consist of a VIP in a thin layer of EPS. The dimension is 600 x 300 x 70 mm. The elements are part of a system with jointing elements in EPS ensuring that the whole floor area is covered. The upper side has a pattern to fit a district- or central heating system. Metal sheets between the elements and the pipes for the heating system ensure that the heat is well distributed to the overlying structure. Estimated service life for VIP is related to the thermal resistance after a given time. [8]



*Figure 2 Installation of Comfort floor system*

### **2.1.2 Model building**

A model of 1960s single family dwelling typical for Norway has been used for this study. This building is a two story wooden house with a net area of 160 m<sup>2</sup> evenly distributed over the two floors. For this study the climatic situation is corresponding to Oslo, Norway, is applied. Two scenarios are investigated, one where the building is in its original state and one where the building has been retrofitted to fulfil the TEK10 standard for all building elements except for the floor insulation. [10] Then three different concepts for the floor construction are applied, keeping the original floor structure, installing the Comfort Floor system with encapsulated VIP and installing conventional VIP. The different systems are presented in Table 1.

*Table 1 Overview of different building standards and floor concepts*

	Standard	Floor concept	U-values floor system
Floor 1	1960	Original	0,270
Floor 2	1960	VIP in EPS	0,133
Floor 3	1960	VIP	0,125
Floor 4	TEK10	Original	0,270
Floor 5	TEK10	VIP in EPS	0,133
Floor 6	TEK10	VIP	0,125

## **2.2 Implementation**

### **2.2.1 Floor concept VIP in EPS**

VIP in EPS elements can be installed directly on the existing floor structure. Over the panels, a metal plate is applied to evenly distribute the heat from the floor heating system. The elements and metal plates are designed with ducts for water pipes to fit precisely. Over the elements, a geotextile is installed under 25 mm. of leveling screed.

For this study, geometric boundaries entail a maximum coverage for the VIP in EPS elements of 96 % of the total floor area. The thermal conductivity for the panels is set to the recommended design value for VIP,  $\lambda=0,007$  W/mK. [11] For the remaining area, adjustment EPS elements are applied.

One of the benefits of this system is that the VIP is protected from cuts and mechanical stress during transport, installation and use. It is designed to accommodate a heating system, and the EPS adjustment elements fills in any area where the VIP in EPS elements does not fit. The draw backs are that it is more difficult to cover the whole area with VIP panels due to the



fixed element dimensions. Furthermore, it is more expensive to install given the required leveling screed, and demand mm of the original ceiling height.

### **2.2.2 Floor concept VIP**

VIP panels can be installed directly on the existing floor structure. Over the panels, a floating floor can be used. For this study, it has been assumed that the panels cover the entire floor area. The thermal conductivity for the panels is set to the recommended design value for VIP,  $\lambda=0,007$  W/mK,

One of the benefits of this system is that it is easier to adjust to the given floor dimensions. Furthermore, it is less expensive to install, and demand less of the original ceiling height. The draw backs are that the VIP is not protected from cuts and mechanical stress during transport, installation and use.

### **2.2.3 Building restrictions**

The VIP in EPS elements combined with the required leveling screed will add 95 mm. to the existing floor construction. Using VIP panels alone, approximately the same thermal heat resistance is given by the same VIP as in the elements. Therefor this dimension is used in the study adding 30 mm. to the existing floor structure. In the model building, the ceiling height is according to the required height for living spaces in Norway [10], which is 2400 mm. The ceiling height after installing the suggested floor concepts will be respectively 2305 mm. for the Comfort Floor system and 2370 mm. for applying the VIP solitarily.

## **2.3 Simulation tools**

### **2.3.1 SIMIEN**

SIMIEN is a simulation tool for calculating the energy demand for a building. According to the technical standard of the building, energy use, distribution of different energy sources and indoor climate is evaluated. Further, a comparison to the building regulations can be made. Issues as dimensioning of energy delivery systems and ventilation systems are addressed.

For the SIMIEN simulations in this work, the energy price is set to 0,80 NOK/kWh. The CO<sub>2</sub> emission related to the energy production is set to 355 g/kWh.

Investment costs for VIP is one of the major challenges for conventional use. To study the economic benefits of retrofitting the floor using VIP, the reduced energy demand is compared with the estimated investment costs as stated in IEA/ECBCS Annex 39, Subtask B. [12] After conversions from the stated price in EURO, the subscribed cost is calculated to 1175 NOK/m<sup>2</sup>.

### 2.3.2 THERM

THERM is a two-dimensional modeling tool for building applications used to perform heat-transfer analysis. By applying the given construction built up, the heat transfer properties and boundary conditions, i.a. the temperature distribution and energy flux can be calculated using the finite-element method. In this work, THERM is used to visualize the heat loss caused by the thermal bridge for the transition between the floor and the outer wall.

## 3 Results

### 3.1 SIMIEN

Figure 2 shows the relation between the systems U-value and change in the thermal conductivity for the VIPs due to ageing. This is important to keep in mind when applying these systems.

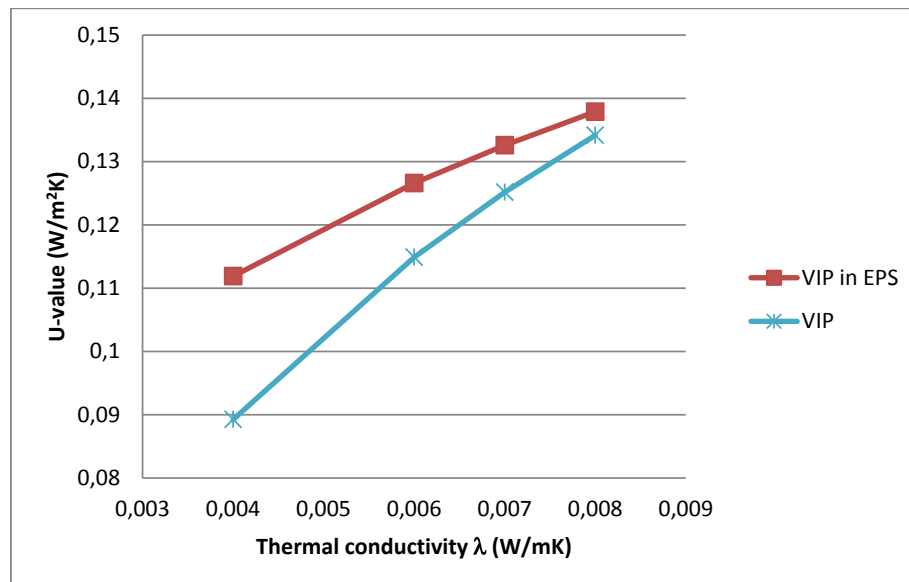

Figure 3 System U-value for different thermal conductivities of the VIP

Table 2 shows the required space heating and delivered energy connected to the different systems. Notice that delivered energy is larger than the total energy consumption. This study however looks at the relative difference in energy demands for the different systems.

*Table 2 SIMIEN simulation results, delivered energy*

Standard	Floor system	Space heating		Delivered energy		Total U-value
		kWh	kWh/m <sup>2</sup>	kWh	kWh/m <sup>2</sup>	
1960	Original	21803	136,3	34090	218,2	1,69
1960	VIP in EPS	21084	131,8	34110	213,2	1,64
1960	VIP	21055	131,6	34078	213,0	1,64
TEK10	Original	6034	37,7	19735	123,3	0,86
TEK10	VIP in EPS	5456	34,1	19077	119,2	0,81
TEK10	VIP	5433	34,0	19051	119,1	0,81

### 3.2 THERM

Figure 3-6 shows the isotherm and the heat flux for the different systems. The thermal bridge for the systems is clearly shown in all the examples. It is significantly reduced for the VIP system compared with the VIP in EPS systems. This especially applies to a poorly fitted VIP in EPS layout. Further, the joints between the elements consist of only EPS and would affect as thermal bridge for the system.

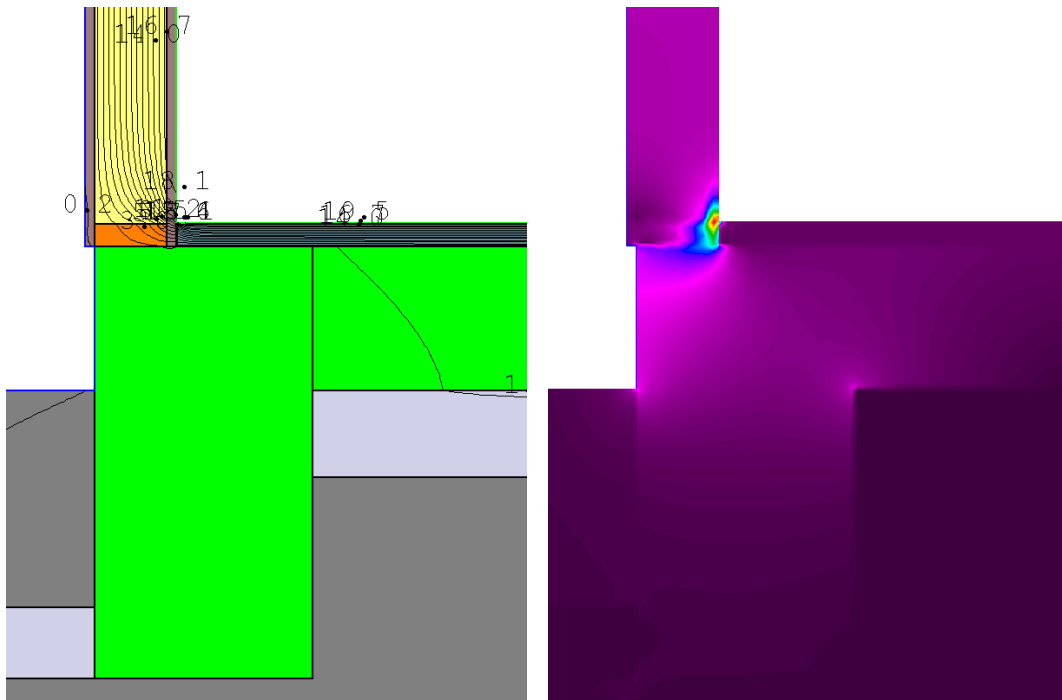

Figure 4 Installation of VIP. Left: System build-up and isotherm plot. Right: Heat flux showing large heat flow.

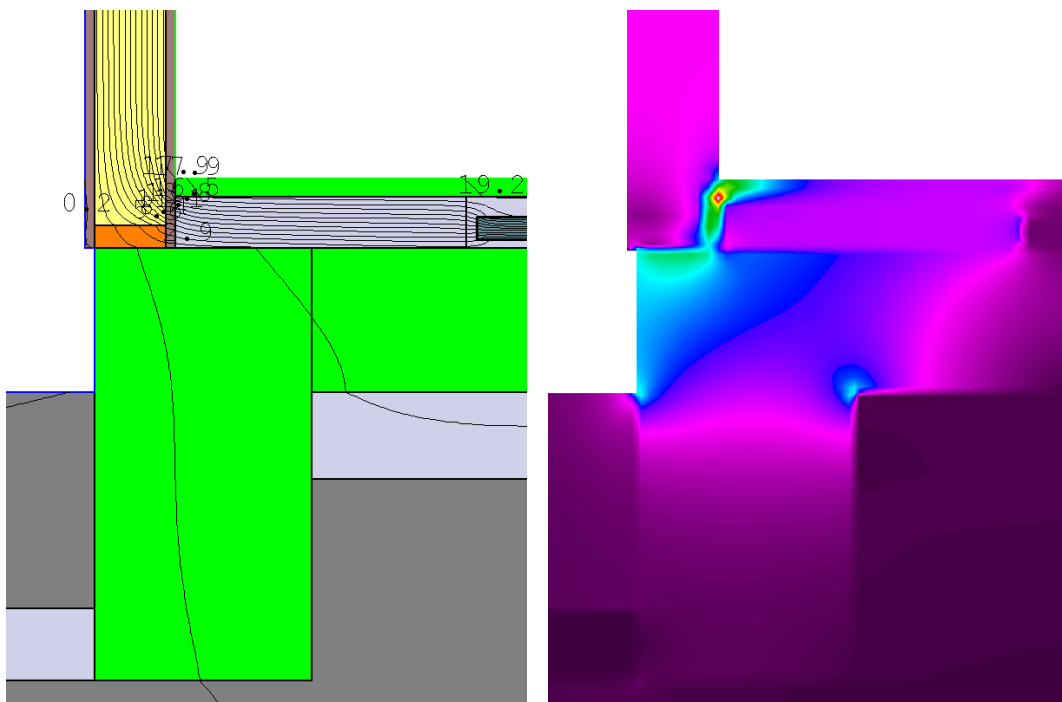

Figure 5 Installation of VIP in EPS (poor fitting). Left: System build-up and isotherm plot. Right: Heat flux showing large heat flow.

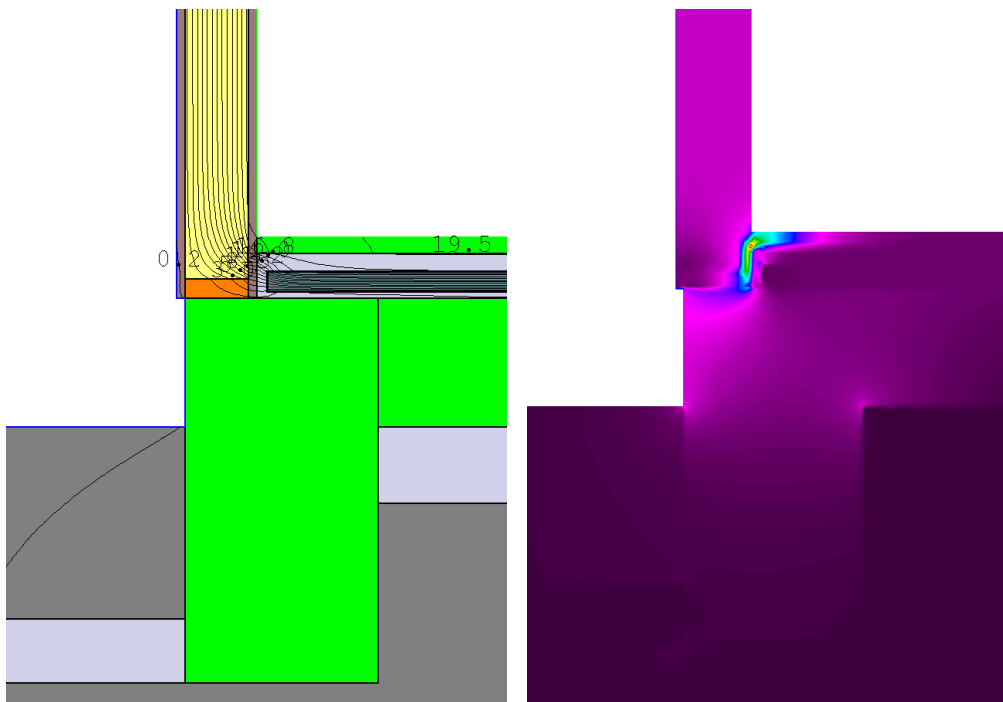

Figure 6 Installation of VIP in EPS (middle plane of panels). Left: System build-up and isotherm plot. Right: Heat flux showing large heat flow.

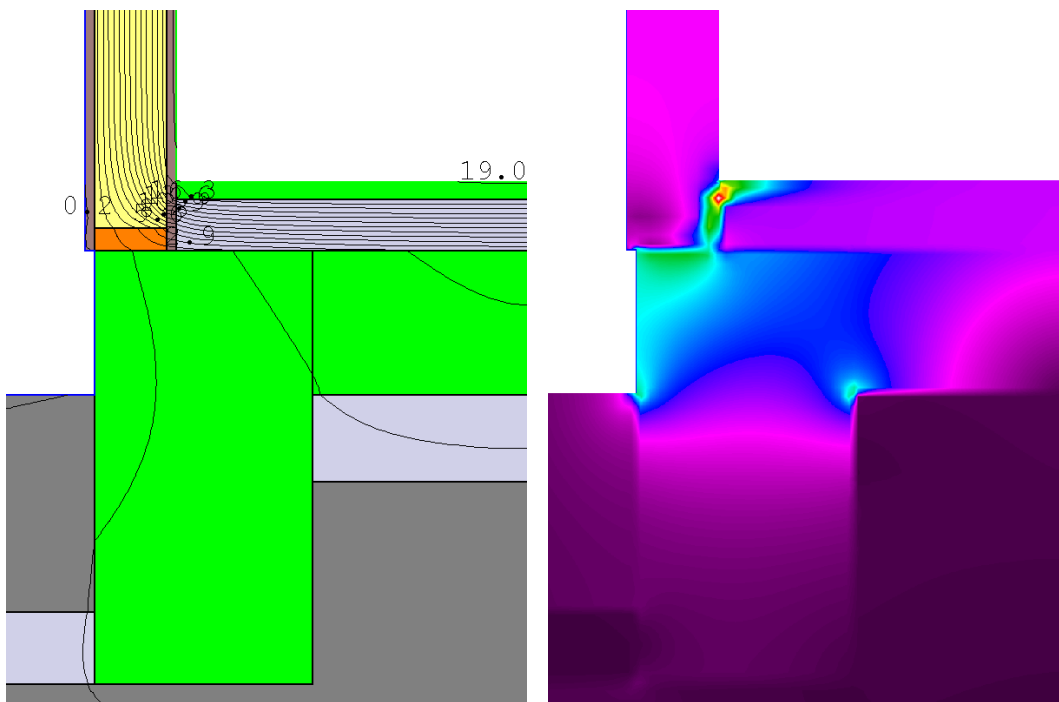

Figure 7 Installation of EPS (or VIP in EPS between panels). Left: System build-up and isotherm plot. Right: Heat flux showing large heat flow.

### 3.3 Economic impact

Table 3 shows the economic impact related to delivered energy and energy costs for the different systems. The payoff time is calculated using an interest rate of 0%. Still, the costs for the systems are clearly high compared with expected service life for VIPs.

*Table 3 Economic impact from the systems*

Standard	Floor system	Delivered energy		Energy costs		Payoff time
		kWh	kWh/m <sup>2</sup>	NOK	NOK/m <sup>2</sup>	Years
1960	Original	34090	218,2	27927	174,5	-
1960	VIP in EPS	34110	213,2	27288	170,6	301
1960	VIP	34078	213,0	27262	170,4	287
TEK10	Original	19735	123,3	15788	98,7	-
TEK10	VIP in EPS	19077	119,2	15262	95,4	356
TEK10	VIP	19051	119,1	15241	95,3	346

Table 5 and 6 shows sensitivity analysis related to the service life time, energy prices and investments costs.

*Table 4 Sensitivity of parameters included in the pay-off time calculations. An interest rate of 0 % has been applied.*

Panel Lifetime	PV	Energy price	PV	Investment cost	PV
yrs	NOK/m <sup>2</sup>	NOK/kWh	NOK/m <sup>2</sup>	NOK/m <sup>2</sup>	NOK/m <sup>2</sup>
25	-1071	0,4	-1071	588	-380
50	-967	0,8	-967	1175	-967
75	-863	1,2	-863	1763	-1555

*Table 5 The maximal allowed investment cost of VIP in EPS per square metre for variues service life times and energy prices.*

Energy price	Max investment cost at 5%			Max investment cost at 0 %		
	25 yrs	50 yrs	75 yrs	25 yrs	50 yrs	75 yrs
NOK/kWh	NOK	NOK	NOK	NOK	NOK	NOK
0,4	52	104	156	29	38	41
0,8	104	208	312	59	76	81
1,2	156	312	468	88	114	122
2,5	325	650	975	183	237	253
5	650	1300	1950	366	475	507
10	1300	2600	3900	733	949	1013

### 3.4 Environmental impact

Table 6 shows the environmental impacts related to delivered energy and CO<sub>2</sub> emissions for the different systems.

*Table 6 Environmental impact from the systems*

Standard	Floor system	Delivered energy		Emissions CO <sub>2</sub>	
		kWh	kWh/m <sup>2</sup>	kg	kg/m <sup>2</sup>
1960	Original	34090	218,2	12393	77,5
1960	VIP in EPS	34110	213,2	12101	75,6
1960	VIP	34078	213,0	12074	75,5
TEK10	Original	19735	123,3	7006	43,8
TEK10	VIP in EPS	19077	119,2	6766	42,3
TEK10	VIP	19051	119,1	6743	42,1

## 4 Discussion

The results from the SIMIEN simulations shows that the economic and environmental savings related to the two floor insulation concepts are minor compared with the original energy demand and CO<sub>2</sub> emissions. The economic saving potential for the model building is approximately 1000 NOK/year for both floor insulation concepts. The installation costs are ignored in these calculations, entailing an increased cost per m<sup>2</sup>. Furthermore, the profitability analysis is carried out with an interest rate at 0% in order to give a favorable evaluation. When the interest rate is set to a moderate level of 5%, the electricity price must be increased by a factor of 10 for the investment to pay off after 75 years. This requires the service life of the VIP to also be 75 years. With these premises, other investments would easily give a greater yield.



Production costs connected to VIP is the major challenge in order to make this a more favorable solution for mainstream insulation for the building envelope. A decreasing production cost could be seen over time, as this is still a relatively new product. The electricity prices are also a factor in the analysis that greatly influences the economic outlook. Increased energy demands in a global perspective and political guidelines in addition to less accessible oil and gas may all lead to increased electricity prices. For the profitability analysis, a 50% increase in the electricity costs to 1,2 NOK/kWh. was applied as an realistic estimate for the service life evaluated in this study. In reference to the analysis, the investment cost should still be reduced to approximately 500 NOK/m<sup>2</sup> for the investment to be profitably. If including the 5% interest rate, it should be decreased to close to 150 NOK/m<sup>2</sup>, or 250 NOK/m<sup>2</sup> if the electricity price is to increase even more to 2,5 NOK/kWh.

The profitability analysis shows that the economic saving potential alone cannot justify the investment costs. Other intensives connected to the suggested floor insulation concepts must be evaluated. The surface temperature for the interior floor is vital to the climatic comfort in a building. This effect is experienced in such an extent that a floor heating system is said to reduce the needed indoor temperature to give the same climatic comfort for the users. It is likely that insulating the original floor, with or without a floor heating system, will give such an effect. Thus, energy costs can be additionally reduced together with an increased contentment for the users. This is also in cohesion with todays expected comfort level in domestic buildings.

Furthermore, both floor insulation concepts fulfil the demands related to thermal heat resistance given by the building regulations in TEK10 when applied to the retrofitted building. [10] All major renovations on existing buildings must correspond to these minimum requirements. With VIP, this is possible without interfering with other building elements as the roof or fundament structures. Hence, the costs related to alternative retrofitting strategies could well be similar or even higher to the estimated costs found in this study. Given the technical difficulties connected to such alterations, the floor insulation concepts suggested seems more reasonable.

The new interior ceiling heights when applying the two different floor insulation concepts are both within the building regulations. [10] Even so, the difference between the two solutions might be noticeable; hence the solution with VIP is favorable. The simpler installation and lower costs strengthen this advantage. The comfort floor system has a major advantage related

to the mechanical protection of the VIP foil. Whether this corresponds to the advantages connected to the VIP is uncertain.

## **5 Conclusion**

The high production costs for the VIPs make this solution not favorable in economic terms. Change in production costs or electricity prices could make this more profitable. Other advantages must be taken in to account in order to justify the investment costs within today's situation. Simpler installation compared with alternative solutions and indoor climatic comfort are properties that could affect the foundation. Both systems can fulfil the governmental requirements related to thermal conductivity when installed in a building where other elements is according TEK10 standard.

## **Acknowledgements**

This report has been written within the *Research Centre on Zero Emission Buildings* (ZEB). The authors gratefully acknowledge the support from the Research Council of Norway, BNL – Federation of construction industries, Brødrene Dahl, ByBo, DiBK – Norwegian Building Authority, DuPont, Enova SF, Entra, Forsvarsbygg, Glava, Husbanken, Hydro Aluminium, Isola, Multiconsult, NorDan, Norsk Teknologi, Protan, Skanska, Snøhetta, Statsbygg, VELUX, Weber and YIT.

## References

1. Thormark, C., *A low energy building in a life cycle—its embodied energy, energy need for operation and recycling potential*. Building and environment, 2002. **37**(4): p. 429-435.
2. Sandberg, N.H., H. Bergsdal, and H. Brattebø, *Historical energy analysis of the Norwegian dwelling stock*. Building Research & Information, 2011. **39**(1): p. 1-15.
3. Dixon, T., *Sustainable Urban Development to 2050: Complex Transitions in the Built Environment of Cities*. WP2011/5 October, 2011.
4. Sartori, I., B.J. Wachenfeldt, and A.G. Hestnes, *Energy demand in the Norwegian building stock: Scenarios on potential reduction*. Energy Policy, 2009. **37**(5): p. 1614-1627.
5. Simmler, H. and S. Brunner, *Vacuum insulation panels for building application Basic properties, aging mechanisms and service life*. Energy and Buildings, 2005. **37**(11): p. 1122-1131.
6. Schwab, H., et al., *Prediction of service life for vacuum insulation panels with fumed silica kernel and foil cover*. Journal of thermal envelope and building science, 2005. **28**(4): p. 357-374.
7. Schwab, H., et al., *Permeation of different gases through foils used as envelopes for vacuum insulation panels*. Journal of thermal envelope and building science, 2005. **28**(4): p. 293-317.
8. Baetens, R., et al., *Vacuum insulation panels for building applications: A review and beyond*. Energy and Buildings, 2010. **42**(2): p. 147-172.
9. Wegger, E., et al., *Aging effects on thermal properties and service life of vacuum insulation panels*. Journal of Building Physics, 2011. **35**(2): p. 128-167.
10. DiBK, *Teknisk Forskrift*, Lovdata.
11. IEA/ECBCS, *Annex 39 - Subtask A Study on VIP-components and Panels for Service Life*

### *Prediction of VIP in Building Applications*

12. IEA/ECBCS, *Annex 39 - Subtask B Vacuum Insulation Panels in the building sector - systems and applications*. 2005.