

PROBABILISTIC EVALUATION OF FPSO-TANKER COLLISION IN TANDEM OFFLOADING OPERATION

By

Haibo Chen



Department of Marine Technology
Faculty of Engineering Science and Technology
Norwegian University of Science and Technology

January 2003
Trondheim – Norway

A B S T R A C T

Collisions between FPSO and shuttle tanker in tandem offloading operation have caused a growing concern in the North Sea. Several recent contact incidents between FPSO/FSU and shuttle tanker have clearly demonstrated a high likelihood of contact between vessels in tandem offloading. The large masses involved, i.e. the high potential impact energy, make the collision risk large. Traditional ship/platform collision frequency modeling may not be applicable in the tandem offloading context. Moreover, offshore quantitative risk analyses generally focus more on technical aspects, little on human and organizational aspects. This leads to a hardware-dominated risk reduction approach, and it has been proved not to be effective to mitigate risks involved in complex marine operations in general.

Frequency modeling of collision between FPSO and shuttle tanker in offloading operation is carried out in this study. The collision frequency model is structured in two stages, i.e. the *initiating* stage and the *recovery* stage, where the former involves an uncontrolled forward movement of tanker, and the latter involves the recovery actions initiated from tanker and FPSO to avoid the collision.

In the *initiating* stage, this study focuses on tanker drive-off forward scenarios. Macroscopically, the frequency of tanker drive-off ahead during offshore loading and specifically during tandem offloading is portrayed by statistical data from an earlier study, recent SYNERGI incident data, and expert judgments made by tanker DP operators. Relatively high frequency values of tanker drive-off in tandem offloading are found. Microscopically, the tanker drive-off ahead scenario is investigated by examining 9 such events in tandem offloading based on investigation reports, interviews and discussions with individuals who directly or indirectly were involved. Findings reveal that in order to effectively reduce tanker drive-off in tandem offloading, efforts should be targeted on minimizing those failure prone situations, i.e. the excessive relative motions (termed as surging and yawing) between FPSO and tanker. A simulation-based study is carried out to quantitatively assess and effectively minimize the occurrence of excessive surging and yawing events. Horizontal motions of FPSO and tanker in tandem configuration are simulated via a state-of-the-art time-domain simulation code SIMO. Findings demonstrate that excessive surging and yawing events can be effectively minimized via measures such as minimizing FPSO surge and yaw motions in offloading, coordinating mean heading between FPSO and tanker, and using the dedicated DP software with the tandem loading function on tanker. Ultimately, these measures may provide a sound operational environment where the possibility of tanker drive-off can be minimized.

In the *recovery* stage, this study is focused on the recovery action initiated by the tanker DP operator. Possible recovery actions are identified and evaluated. Based on calibrated tanker motion simulations, the allowable time for DP operator to initiate recovery

action, so that tanker can be stopped within a separation distance, e.g. 80 m to FPSO, is found to be critically short. A 3-stage information-decision-execution model is generalized to model the DP operator's information processing stages regarding action initiation when in a drive-off scenario. Based on this human information-processing model, expert judgment by simulator trainer and questionnaire survey among shuttle tanker captains and DP officers are conducted, reasonable estimates of the time needed for action initiation are obtained. The estimates are found to be convergent to the facts in the incidents. Findings suggest that tanker DP operators in general need more time to initiate recovery action than the allowable time window, i.e. recovery failure is likely due to lack of reaction time. Two principal recommendations are proposed to reduce the recovery failure probability, i.e. to provide a longer time window for the operator to initiate recovery action, and/or to provide various kinds of assistance to the operator to reduce the recovery action initiation time.

To increase the time window, a promising measure is to substantially increase the separation distance between FPSO and tanker, e.g. from 80 m to 150 m. The feasibility of this measure is discussed from a number of perspectives. Recovery improvement gains are assessed. The key question concerning implementation is to know how much separation distance should be configured in the operation. This has to be based on considerations of both human operators' need for reaction time, and tanker drive-off behavior. Parametric tanker drive-off motion simulations are carried out in which human action at various times are imposed. The necessary distance values to stop the tanker are then obtained, and ideally these should correspond to the separation distance values between FPSO and tanker in tandem offloading. These findings provide decision-making support to select an optimum field configuration for FPSO-tanker tandem offloading, which may inherently minimize the collision risk.

Effective reduction of reaction time can be achieved by early detection and/or quick decision-making. This is based on the operator information-processing model generalized earlier in this study. Measures to improve early detection are identified. Discussions are guided by the human signal detection theory, and supported by the operational facts of alarm and non-alarm signals in the operation. Measures to effectively reduce the operator's time involved in diagnosis and situation awareness are also identified. They are theoretically built on the generic human decision-making theory, and specifically designed for drive-off intervention based on the facts collected via a questionnaire survey among shuttle tanker captains and DP officers. These findings illuminate a broad area in the human factor perspective, i.e. training, procedure, crew resource management, human-machine interface, and automation support, where measures to reduce operator reaction time should be targeted. These measures may directly reduce the FPSO-tanker collision risk in tandem offloading.

A C K N O W L E D G E M E N T S

I first want to thank my supervisor, Professor Torgeir Moan. In the past four years Torgeir has been a supervisor, a mentor, and gradually also a close friend to me. We have our traditional *Monday's Dr.Ing Talk* which was started in the early days of my Dr.Ing journey – when everything, e.g. risk analysis, human and technical factors, and so on, were flying around in the air, and has lasted up to the present – where fact-based models and analyses are rooted down in the soil. Together we had those inspired moments when we had a break-through in the research, and low periods when progress was stagnant. Torgeir has always been the first (and in many cases also the last) helping hand for me, supporting initiatives and of course helped me back on track in my digressions.

Risk modeling in this study has to be built on a thorough understanding of the practical operation. An important yet particularly challenging step for me is to setup contacts with the industry. I am very grateful to have met Professor Jan Erik Vinnem who introduced me to the FPSO Operational Safety JIP. This is a precious link between the university and the industry, which was initiated when Jan Erik invited me to give a brief talk at the JIP steering committee meeting on 8 December 1999. After this meeting, I joined the group as an observer, and several months later I became a member of the JIP research team. The activities in this JIP have benefited my Dr.Ing study significantly, and I am deeply indebted to Jan Erik for his continuous help, support, and encouragement throughout these years.

Needless to say, FPSO and shuttle tanker operators are of vital importance to my Dr.Ing study. Statoil and Navion are two organizations to acknowledge as a whole; but I would also like to thank the following people in particular.

Dr.Ing Sverre Haver at Statoil. I am very grateful and very lucky to have met Sverre. We formally started our contact on my first visit to the Statoil Head Office in Stavanger on 30 June 2000. The hydrodynamics involved in tandem offloading is a crucial risk contributor. Time-domain simulation of FPSO-tanker motion was the approach Sverre and I identified in our meeting on that day. Since then, I have always looked forward to every status meeting that we have had, which proceeded passing each milestone, i.e. computer program familiarization, vessel model and environment input setup, model calibration based on full-scale motion measurement, statistical modeling, and later tanker drive-off simulation, and so on. Every single step involved would have been a daunting task if without generous and continuous help from Sverre, and later also his colleagues, Mr. Kjell Larsen and Mr. Harald Kleppestø, and also Dr.Ing Trond S. Meling at the early stage. These kind people are gratefully acknowledged here.

Mr. Leif Ivar Tønnessen in Navion is one that I am very much indebted to. We first met on the steering committee meeting of FPSO Operational Safety JIP on 13 November

2001. Leif Ivar provided me with a great deal of tandem offloading operational data regarding, for example, shuttle tanker crash-stop characteristics, tanker propulsion response data, recovery alternatives from DP operator in tanker drive-off. He also introduced me to his colleague, Mr. Kjell Helgøy, a resourceful Navion specialist on DP systems and incident investigation, whom I would also like to thank. And my intended questionnaire survey with shuttle tanker captains and DP officers would never have been possible if without Leif Ivar's warm-hearted support and help. Those valuable operational data offered me a concrete basis for an important part of my Dr.Ing study – the human initiated recovery in tanker drive-off.

In human factor and human reliability studies, nothing is probably more frequently mentioned than training. The training institute Ship Manoeuvring Simulator Centre (SMS) in Trondheim is sincerely acknowledged. Specifically, I want to give a big thank-you to Instructor/Captain Helge Samuelsen in the SMS for supporting me a lot of valuable tandem offloading operational data. Helge has years of extensive experience of tanker offshore loading simulator training, and he has been very supportive since day one, 21 September 2000, when I visited him. I still remember vividly the 5-day simulator training course 'Offshore Loading Phase 2' given by Helge, which I followed as an observer in the SMS during 11-15 December 2000. This fresh experience bridged my mental gap between written procedures and actual operation. I also directly observed the human responses in those simulated tanker drive-off scenarios. Afterwards I realized that the situation often could be far more complicated than what had tidily been stated in the final investigation report.

The observation of a real tandem offloading operation, discussions of hands-on experience and problematic areas in the operation came from the 5-day visit onboard M/T Navion Oceania during 28 June – 02 July 2001. First I want to thank Captain Bjørn Kåre Hammersvik and 1st Officer Petter Johan Ellingsen for their patient explanation of operational details, detailed walk through and talk through practices, and insightful information about incidents and near misses. I also would like to thank the Navion people and Professor Jan Erik Vinnem (again) for arranging this valuable and memorable trip, and other FPSO Operational Safety JIP team members – Senior Research Scientist Per Hokstad and Ms. Hilde K. Sæle in SINTEF, for their help in many ways during this trip.

Research can't be done in a vacuum. The connections with other risk analysts have proved valuable. I am particularly grateful that I met the former managing director of Safetec (now within CorrOcean), Dr.Ing Stein Haugen, on 5 March 1999. That was only one month after I had started this Dr.Ing study. He helped me with an arrangement of literature reading regarding various FPSO risk projects and safety cases documentation in the Safetec Trondheim office in July 1999. This early exposure to the offshore risk analysis projects was very valuable to me, and it set the tone of my study. I also talked with Haugen's colleagues, Mr. Frank Vollen and Mr. Jon Daniel Nesje, on various topics. I appreciated all the help, insights and suggestions from the people at Safetec at that stage of my study.

With the involvement in FPSO Operational Safety JIP, I had contact with several people in SINTEF Industrial Management, Safety and Reliability Section. I would like to thank

Mr. Stein Hauge and Dr.Ing Ragnar Rosness for their suggestions in relation to my study until Autumn 2000. Afterwards I am grateful to have had many discussions with Senior Research Scientist Per Hokstad, Ms. Hilde K. Sæle, and later Mr. Terje Dammen regarding the FPSO Operational Safety JIP work. They inspired many ideas that have been implemented in this Dr.ing study. I also appreciate to have contact with Mr. Oliver Kieran in Offshore Safety Division in Health & Safety Executive (HSE) in the UK. Many thanks for his warm encouragements since the day we met in December 1999, and his kind help when I was in the HSE London Office for incident data collection. Oliver's colleague, Mr. Andrew D. Moyses in HSE, is also acknowledged for helping me on several occasions on various UK FPSO data since February 2001.

Some people may just have a very brief appearance in this Dr.Ing journey, but their contributions have made my work very different. Professor Asgeir Sørensen reviewed the dissertation draft and made many valuable technical (and linguistic) comments. Mr. Svein-Arne Reinholdtsen at Marintek/NTNU helped me with the SIMO program, and Marintek is acknowledged for granting the use of this computer program in my study. Mr. Torbjørn Hals and Mr. Kjetil Gudmestad in Kongsberg Simrad clarified DP software details and provided tanker propulsion information to me. Mr. Tony Read in IMCA (International Marine Contractors Association) offered me a free copy of that valuable report: 'Quantified frequency of shuttle tanker collision during offtake operations'. Finally, Ms. Anja Angelsen proof-read the dissertation draft thoroughly and provided many corrections. I want to thank all these people for their kind help.

Last but not least, my Dr.Ing study was financially supported partly by the fellowship from the Research Council of Norway and partly by the stipend from Statoil. These supports are very appreciated.

Haibo Chen

19 January 2003

C O N T E N T S

1. INTRODUCTION	1
1.1 BACKGROUND	1
1.2 MOTIVATION	4
1.3 OBJECTIVES	6
1.4 LIMITATIONS	6
2. MODELING OF COLLISION	8
2.1 MODEL CONSTRUCTION	8
2.2 MODEL APPLICATIONS	9
3. DRIVE-OFF INITIATION	11
3.1 FREQUENCY OF DRIVE-OFF	11
3.1.1 <i>Earlier study</i>	12
3.1.2 <i>SYNERGI incident data study</i>	13
3.1.3 <i>Expert judgments from tanker operators</i>	15
3.2 ANALYSIS OF INCIDENTS	17
3.3 PROBABILISTIC MODELING OF DRIVE-OFF	20
3.4 QUANTIFICATION – FAILURE PRONE SITUATIONS	22
4. SURGING AND YAWING	25
4.1 INTRODUCTION	25
4.2 SIMULATION-BASED APPROACH	28
4.2.1 <i>Feasibility</i>	28
4.2.2 <i>Procedures</i>	29
4.2.3 <i>Limitations</i>	30
4.3 VESSEL MODELS	30
4.4 ENVIRONMENTAL CONDITIONS	32
4.5 BASE CASE RESULTS	34
4.6 SENSITIVITY STUDIES	35
4.6.1 <i>Surging and contact events</i>	35
4.6.2 <i>Yawing events</i>	37
4.7 FINDINGS AND RECOMMENDATIONS	38
5. FAILURE OF RECOVERY	40
5.1 PROBABILISTIC MODELING AND OPERATIONAL DATA	41
5.2 RECOVERY ACTION IDENTIFICATION	41
5.3 TIME WINDOW FOR SUCCESSFUL RECOVERY	43
5.4 MODELING OF ACTION INITIATION	44
5.5 TIME NEEDED FOR ACTION INITIATION	46
5.5.1 <i>Incident information</i>	47
5.5.2 <i>Expert judgment</i>	47
5.5.3 <i>Questionnaire survey</i>	48
5.6 FAILURE OF RECOVERY	50
5.7 FAILURE REDUCTION MEASURES	50
6. INCREASE TIME WINDOW	55
6.1 FEASIBILITY	55
6.1.1 <i>Separation distance extension</i>	55

6.1.2	<i>Main propeller thrust reduction</i>	57
6.2	GAIN FROM SEPARATION DISTANCE EXTENSION	58
6.3	DESIGN A REASONABLE SEPARATION DISTANCE	60
7.	REDUCE REACTION TIME	63
7.1	ABNORMAL SIGNALS	64
7.2	IMPROVING EARLY DETECTION – ALARM SIGNAL	65
7.3	IMPROVING EARLY DETECTION – NON-ALARM SIGNAL	66
7.4	MODELING OF DIAGNOSIS AND SITUATION AWARENESS	68
7.5	FACTS FROM QUESTIONNAIRE SURVEY	70
7.6	MEASURES TO REDUCE DECISION TIME	72
7.6.1	<i>Training</i>	72
7.6.2	<i>Proceduralization</i>	72
7.6.3	<i>Automation</i>	73
8.	CONCLUSIONS AND FUTURE WORK	74
8.1	CONCLUSIONS	74
8.1.1	<i>Modeling of FPSO-Tanker collision</i>	74
8.1.2	<i>Probability of tanker drive-off</i>	75
8.1.3	<i>Probability of recovery failure</i>	75
8.2	SUGGESTIONS FOR FUTURE WORK	76
8.2.1	<i>Level I</i>	76
8.2.2	<i>Level II</i>	77
8.2.3	<i>Level III</i>	78
	REFERENCES	80
A.	THEORETICAL BACKGROUND	87
A.1	RATIONALE BEHIND THE COLLISION FREQUENCY MODEL	87
A.1.1	<i>Human supervisory control</i>	87
A.1.2	<i>Human-Machine system dynamics</i>	89
A.1.3	<i>Operational safety modeling</i>	90
A.2	HUMAN ACTION, ERROR, AND RELIABILITY	91
A.2.1	<i>Human action</i>	91
A.2.2	<i>Human error</i>	92
A.2.3	<i>Human reliability</i>	93
A.3	HUMAN INFORMATION PROCESSING MODELS	95
A.3.1	<i>S-O-R models</i>	95
A.3.2	<i>Step-ladder model</i>	96
A.3.3	<i>Wickens' model</i>	98
A.4	REFERENCES	99
B.	INCIDENT ANALYSIS	101
B.1	COLLISION INCIDENT A	101
B.2	COLLISION INCIDENT B	102
B.3	COLLISION INCIDENT C	103
B.4	COLLISION INCIDENT D	104
B.5	COLLISION INCIDENT G	105
B.6	NEAR MISS E	106
B.7	NEAR MISS F	107
B.8	NEAR MISS H	108
B.9	NEAR MISS I	109
C.	SIMULATION MODEL CALIBRATION	110
C.1	FPSO AND TANKER MODEL CALIBRATION	110
C.1.1	<i>Passive FPSO model calibration</i>	111

C.1.2	DP FPSO model calibration.....	112
C.1.3	FPSO-Tanker model calibration	114
C.2	FULL-SCALE FPSO-TANKER MOTION MEASUREMENTS	117
C.2.1	Raw data.....	117
C.2.2	Selection of time series	118
C.2.3	Pre-processing of time series.....	118
C.3	THEORY	120
C.3.1	Method overview.....	120
C.3.2	Mass, damping, stiffness and excitation forces.....	121
C.3.3	Wave force (LF).....	122
C.3.4	Wind force	122
C.3.5	Current force	123
C.3.6	Station-keeping forces	123
C.3.7	Coupling force.....	124
C.4	REFERENCES	125
D.	TECHNICAL SYSTEM AND OPERATIONAL PROCESS	126
D.1	SHUTTLE TANKER BRIDGE	126
D.1.1	Bridge layout	126
D.1.2	DP console.....	127
D.1.3	Position reference system	127
D.1.4	Bow loading system console.....	128
D.1.5	Video screen of bow loading area	129
D.2	TANDEM OFFLOADING OPERATION	129
D.3	SPECIAL DP FEATURES	133
D.3.1	FSU Surge/Sway function.....	133
D.3.2	FSU Sway/Heading function.....	134
D.4	REFERENCES	134
E.	QUESTIONNAIRE SURVEY	135

A B B R E V I A T I O N S

BLS	Bow Loading System
CPP	Controllable Pitch Propeller
DARPS	Differential Absolute & Relative Positioning System
DFM	Drift Forward Movement (tanker)
DP	Dynamic Positioning (system)
DWT	Deadweight Tonnage
EOP	Emergency Operating Procedures
EPS	Error Prone Situations
ESD	Emergency Shut Down
FPSO	Floating Production, Storage and Offloading (unit)
FSU	Floating Storage Unit
HCR	Human Cognitive Reliability
HMI	Human-Machine Interface
HRA	Human Reliability Analysis/Assessment
HSE	Health & Safety Executive
IMCA	International Marine Contractors Association
NPP	Nuclear Power Plant
QRA	Quantitative Risk Assessment
OSM	Operational Safety Modeling
PFM	Powered Forward Movement (tanker)
PRS	Position Reference System
SIMO	Simulation of Marine Operation – computer code name
SMS	Ship Manoeuvring Simulator Centre
SPM	Single Point Mooring
ST	Shuttle Tanker
TRC	Time Reliability Correlation
UFM	Uncontrolled Forward Movement (tanker)
UKOOA	Unite Kingdom Offshore Operators Association

C H A P T E R

1. INTRODUCTION

Deal with the hard while it is still easy.¹

– LAO TZU (571 B.C.)

This chapter outlines the background, motivation, objectives, scope and limitations of this Dr.Ing study. It starts with a brief introduction to the floating production, storage and offloading (FPSO) concept and an outline of tandem offloading operations between FPSO and shuttle tanker. There is a practical need to reduce the collision risk between FPSO and shuttle tanker in tandem offloading. Moreover, ship-platform collision risk models from previous offshore quantitative risk assessment (QRA) studies may not be applicable to the tandem offloading context, and there is little consideration of human and organizational contributions in those QRA models. Further development of collision risk modeling and, more importantly, identification of effective measures for reducing the occurrence of collision in tandem offloading are therefore two major objectives of this study. The study scope and limitations are also discussed.

1.1 BACKGROUND

The FPSO concept is based on a combination of traditional ship building technology and platform design. The following definition with respect to FPSO are found in the NORSOK Standard (NTS, 1998):

FPSO - Ship Shaped Floating Production, Storage and Offloading Unit

A floating unit can be relocated, but is generally located on the same location for a prolonged period of time. Inspections and maintenance are carried out on location. The Floating Production, Storage and Offloading unit normally consists of a ship shaped hull, with an internal or external turret, and production equipment on the deck. The unit is also equipped for crude oil storage. The crude may be transported to shore by shuttle tankers via an offloading arrangement.

¹ Lao Tzu (571 BC). *Tao Te Ching*. Translated by Arthur Waley, Wordsworth Editions Ltd., 1997

The overall arrangement of a North Sea FPSO is shown in Figure 1-1. The living quarter and control room are located in the bow, upwind of any hydrocarbon fire. The turret is installed forward of mid-ship. The process area is aft of the turret, elevated from the main deck with natural ventilation. The oil storage is provided by storage tanks, mainly located aft the turret. The offloading system is installed at the stern.

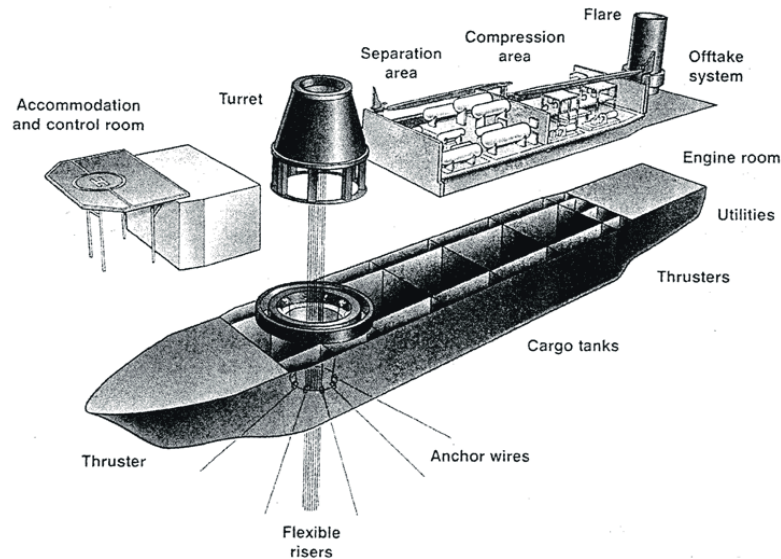

Figure 1-1 A North Sea FPSO configuration¹

FPSOs have been used in the Far East, Africa, and South-America for some decades since the mid-1970s, but these areas are in general benign waters. The wide use of FPSOs in the North Sea, West of Shetland, as well as in other hostile environments actually started in the 1990s, despite that the first North Sea FPSO, Petrojarl I, had been used since 1986. FPSOs are probably by far the most popular floating production system in offshore oil and gas fields worldwide. In the near future, almost 60% of the floating production systems now on order have ship-shape hulls (McCaul, 2001).

With an increasing number of FPSOs in use, the number of shuttle tankers performing crude oil offloading from these FPSOs is growing too. Though some FPSOs may offload oil to shuttle tankers indirectly via remote loading buoy connected to the FPSO by a pipeline, the majority of FPSOs currently do rely on direct offloading to shuttle tanker to transfer oil to the shore. This direct offloading operation is carried out generally via a tandem configuration as shown in Figure 1-2. Alongside offloading is another possibility, but a less-adopted configuration in harsh environments. The tandem offloading is dominant in the North Sea, and is discussed in this study.

¹ Picture adapted from the Journal of Offshore Technology, pp.18, Vol.3, No.2, May 1995.

The tandem offloading means that the shuttle tanker is positioned at some distance, e.g. 80 m, behind the FPSO. The two vessels are physically connected by a mooring hawser and a loading hose through which cargo is offloaded. The tanker may position itself by its own dynamic positioning system so that the hawser is not tensioned (DP mode), or by applying certain astern thrust and maintain a small tension on hawser (Taut hawser mode). Tug or standby vessel assistance may be required for taut hawser mode. The DP tankers have greater uptime in harsh environments and therefore are widely applied in the North Sea. This is the case considered in this study.

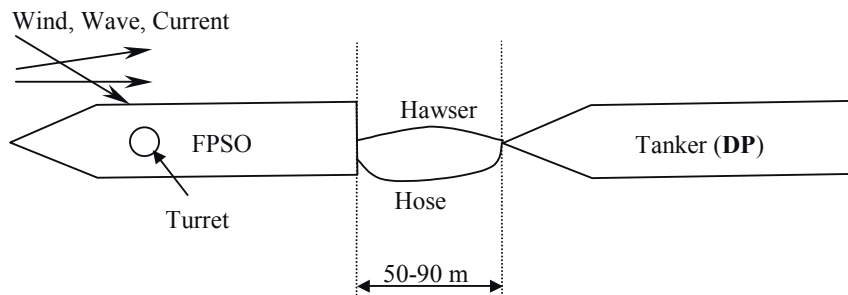

Figure 1-2 FPSO and DP Shuttle tanker in a tandem offloading operation

FPSO and DP shuttle tanker tandem offloading operation can in principle be summarized into the following five operational phases, from the point of view of the tanker (SMS, 2000).

1. Approach: tanker approaches FPSO stern and stops at a wanted distance.
2. Connection: messenger line, hawser and loading hose are connected.
3. Loading: oil is transferred from FPSO to tanker.
4. Disconnection: manifold is flushed, and loading hose and hawser are disconnected.
5. Departure: tanker reverses away from FPSO stern while sending back hawser messenger line, and finally sails away from field.

Detailed description of human-machine system, interface, and operational process involved in a North Sea tandem offloading operation can be found in Appendix D.

The tandem offloading operation is a frequent yet complex and difficult marine operation. It may range from once every 3 to 5 days, depending on the production rate, storage capacity of FPSO, and shuttle tanker size. The duration of the operation can be in the order of 24 hours based on FPSO storage and oil transfer rate. Meanwhile, a suitable environmental condition is required. FPSO may weathervane (rotate according

to the weather) around its turret located either internally or externally, and it may also have significant low frequency motions in the horizontal plane (surge, sway and yaw) due to waves and wind if in harsh environments. In order to stay connected for loading and at the same time maintain a separation distance, e.g. 50-90 m behind FPSO stern, the DP shuttle tanker has to position itself according to the FPSO position.

Offshore loading by shuttle tankers has been carried out in the North Sea for more than two decades (HSE, 1997). Traditionally, this involves shuttle tanker with an articulated loading platform or a spread-moored loading buoy. The situation is dramatically changed in the tandem offloading operation in terms of positioning complexities and damage potential, i.e. the significant amount of mass involved (a 150,000 dwt shuttle tanker, for example) in close distance to an installation (FPSO) for a long duration. However, offloading hardware, software, operational procedures, and so on, which evolve from experience and lessons learned before, largely remain the same in this new context. Shuttle tanker loss of position in powered condition and subsequently collided with FPSO/FSU had been reported a few times. As commented in a recent study by Global Maritime to IMCA (IMCA, 1999), the most significant risk, in terms of tanker offtake, is associated with tandem loading operations.

1.2 MOTIVATION

There are likely five collision incidents between FPSO/FSU and DP shuttle tanker occurred in the North Sea in recent years, based on reference information from Vinnem (1999) and Leonhardsen et al. (2001).

- Emerald FSU: Impact by shuttle tanker Navion Clipper, UK, 28.02.1996
- Gryphon FPSO: Impact by shuttle tanker Futura, 26.07.1997
- Captain FPSO: Impact by shuttle tanker Aberdeen, 12.08.1997
- Schiehallion FPSO: Impact by shuttle tanker Nordic Savonita, 25.09.1998
- Norne FPSO: Impact by shuttle tanker Knock Sallie, 05.03.2000

The collision frequency is relatively large based on the above incident record. The estimated total number of tandem offloading operations by DP shuttle tanker in the North Sea is around two thousand between the years 1996 to 2000 (Helgøy, 2002). This indicates one collision every four hundred offloading operations. For a DP shuttle tanker undertaking fifty tandem loading operations per year, this equals to one collision in the order of every ten years. However, a reasonable interpretation of these statistical results should also include the following fact: The tandem offloading operation between FPSO/FSU and DP shuttle tanker has been in continuous evolution during recent years. The high frequency averaged over these years cannot reflect the significant amount of improvements and efforts made by shuttle tanker and FPSO operators in the mean time.

The collision damage potential is large, due to the large masses, and consequently the large impact energy involved in possible tanker-FPSO collisions. The impact energy in one of the collisions had reached 31 MJ. This is estimated for a 154,000 dwt shuttle tanker at a 0.6 m/s impact velocity from the information in the investigation report (Statoil, 2000). Stern damage on the FPSO may cause penetration and flooding in the machine room. Moreover, with the widely adopted FPSO design, e.g. Gryphon, Captain, Norne, Åsgard, etc. (Addy et al., 1995; Odland, 1995), the living quarters are located in the bow area, thus the flare towers, which have to be located in the stern area, are vulnerable to tanker impact. A worst-case scenario could therefore be a major tanker collision that topples down the flare tower of the FPSO. This can initiate a chain of events with severe fire and explosion on both vessels. From one of the occurred collision incidents, damage of members and bracings of the flare structure did happen (Leonhardsen et al., 2001).

A wide range of parties in the offshore industry, i.e. regulators, technical system designers, shuttle tanker and FPSO operators, training institutions, and risk analysts, are involved in combating the collision problem in tandem offloading. Continuous efforts have been made in recent years to reduce collision frequency and/or consequence, see publications from HSE (1999), the FPSO Operational Safety JIP (Vinnem, 2000), and tandem offloading guidelines by UKOOA (2002). Yet, to control the collision risk in tandem offloading, and particularly to reduce the frequency of collision, involve two basic difficulties arising from offshore QRA methodology. Note that the collision consequence modeling is generally based on energy method and non-linear structural mechanics. Details on this subject can be found in Skallerud and Amdahl (2002).

First, the traditional ship-platform collision frequency modeling may not be suitable for the tandem offloading context which involves FPSO and DP shuttle tanker. Quantitative frequency modeling of ship-platform collision is not a new issue. Furnes and Amdahl (1980) developed their quantitative collision frequency model based on the geometric consideration in the early 1980s. Haugen and Moan (1992) presented in the early 1990s a collision frequency model based on considerations of traffic number, navigation course, and recovery actions from ship and platform. However, these models were primarily developed for a fixed platform and passing vessels. There are some offshore risk studies of FPSO and tanker collision, e.g. by MacDonald et al. (1999) in the recent JIP on "Risk and Reliability of a FPSO in Deepwater Gulf of Mexico". However, in general those studies are few in number, and their applicability to the North Sea and the level of detail of collision frequency modeling are questioned.

Second, offshore quantitative risk studies have traditionally focused more (if not solely) on technical failure events, little on human (and organizational) failure events. However, there is a growing recognition that humans (and organization) do play a role, in connection to structural failures as documented by Bea (1997) and Kvitrud et al. (2001). In tandem offloading operation, the HSE UK also identified that the majority of contact incidents between shuttle tankers and installations during 1997 and 1998 involved "DP problems" and "human factors" (HSE, 1999). This calls for an integration of the modeling of human (and organizational) contributions into the collision

frequency model which is valid for the offloading context between FPSO and DP shuttle tanker.

In summary, there is a practical need to carry out risk analyses in order to reduce the collision frequency in tandem offloading operation, given the relatively large contact frequency and large damage potential at present. To fulfill this need, it is necessary to further develop a quantitative collision frequency model, in which the uniqueness of the tandem offloading context, as well as the human and organizational contributions to the collision frequency can be taken into account.

1.3 OBJECTIVES

The overall objectives of this Dr.ing study are to:

1. Develop a quantitative frequency model to analyze the collision risk between FPSO and shuttle tanker in the tandem offloading operation, taking both technical aspects and operational aspects into account.
2. Exemplify the above modeling approach by case studies based on the collected operational data from the North Sea practices; identify measures to reduce the collision occurrence in tandem offloading.

1.4 LIMITATIONS

Different technical systems, procedures and environments for the tandem offloading operation may imply different collision risk pictures. In this study the technical systems considered are a purpose-built FPSO and a DP shuttle tanker, both for North Sea operations. The operational procedures are in general applicable to the tandem offloadings performed in the North Sea. However, note that the details of the procedures may vary from field to field. The environmental condition applies to the Haltenbanken area in the Norwegian Sea.

Given the fact that pure technical failure events have been exhaustively modeled and analyzed in traditional offshore QRA models, this study emphasizes more on modeling the operational failure events and the interaction between technical and operational events.

There are a few modeling approaches apparently close to the above purpose, e.g. CRIOP (Ingstad and Bodsberg, 1990), Influence Diagram Approach (Embrey, 1992), Risk Influence Analysis (Rosness, 1998), Bayesian Probabilistic Networks (Hansen and Pedersen, 1998; Faber et al., 2001). However, note that each modeling approach is developed from its own original context. To collect facts in tandem offloading, which in itself is unique, and then try to fit the facts into a modeling approach that appears suitable, may not guarantee an effective way of preventing collision. Therefore, none of the above modeling approaches is taken for granted in the study. Instead, a fact-based

modeling approach is adopted which is presented in Chapter 2, Section 2.1; thereafter scope of this study is described in detail.

Ultimately, this study is to come up with effective measures to reduce the occurrence of FPSO-tanker collisions in tandem offloading. Therefore, the quantification efforts in the frequency model are focused on obtaining probabilities in a comparable manner, so that various technical and operational contributions can be pinpointed, and gains from various risk reduction measures can be measured and compared. Implicitly, the risk model is not designed for assessing the acceptability issue; nor is effort made to formulate any collision risk acceptability criteria for the tandem offloading operation.

2. MODELING OF COLLISION

Use models by all means if you find them useful but do not become a slave to them.¹

– TREVOR KLETZ

This chapter presents the overall frequency model of FPSO and shuttle tanker collision in tandem offloading. The rationale behind constructing this model is briefly outlined. The in-depth theoretical background behind the modeling is presented in Appendix A. By a coarse evaluation of possible scenarios, a practical top-level collision frequency model is formulated. Implications of this model are discussed. Though short in size, this chapter is the main thread linking all the following chapters in the study.

2.1 MODEL CONSTRUCTION

For a collision between tanker and FPSO in tandem offloading to happen, irrespective of operational phase, there are two necessary conditions:

- Tanker has uncontrolled forward movement (UFM)
- Recovery actions (initiated from tanker and/or FPSO) fail to avoid the collision

The collision frequency model in tandem offloading can subsequently be expressed as in Eq.2-1.

$$P(\text{Collision}) = P(\text{UFM}_i) \Delta P(\text{Failure of Recovery} | \text{UFM}_i) \quad (2-1)$$

where $P(\text{UFM}_i)$ is the probability of tanker uncontrolled forward movement type i ; and $P(\text{Failure of Recovery} | \text{UFM}_i)$ is the probability of recovery failure initiated from tanker and FPSO, conditioned on tanker UFM type i .

The principle behind this overall modeling is the operational safety modeling (OSM) concept. The theoretical background of the OSM concept, as well as theories that guide

¹ Kletz T. *Learning from Accidents*. 3rd Ed, pp.7, Gulf Professional Publishing, 2001a.

the detailed, further modeling in the following chapters, are provided in Appendix A. Descriptions of theory and methodology are presented in a concise manner which mainly include the following: human-machine system dynamics (Sheridan, 1992; Hollnagel, 1998), quantitative risk modeling (Vinnem, 1999), human reliability and error analysis (Reason, 1990; Kirwan, 1994), and modeling of operator action (Rasmussen, 1986; Wickens and Hollands, 2000).

The tanker uncontrolled forward movement (UFM) may be initiated in powered condition, termed as powered forward movement (PFM) scenario which is also called the drive-off forward scenario in this study. The PFM may be initiated by various technical system failures, erroneous operational actions, or a combination of both. The tanker UFM may also be initiated in drift condition when the tanker loses all its power, and the resultant environmental forces “push” the tanker towards the FPSO. This is termed the drift forward movement (DFM) scenario.

The DFM scenario is considered a low probability and low consequence event, and it is therefore excluded from the further modeling. The reasons are: Firstly, tanker blackout during offloading is not a frequent event. Secondly, given that event, the resultant environmental forces, due to weathervane, will typically drift the tanker away from instead of towards the FPSO. Certainly, there may be cases where the tanker is heavily loaded, and wind and waves are small, where the tanker is under dominant influence from current, and current may drift the tanker ahead. However, in such cases, the tanker typically will not gain much speed within an 80-100 m distance to the FPSO stern.

The recovery actions are mainly initiated from tanker, specifically by the tanker DP operator, to stop the tanker or steer it away from the FPSO stern. The FPSO crew may also take action, e.g. using the main screw to create current to blow the tanker away, or, in principle, change heading. However, in a tanker PFM scenario, the FPSO-created current cannot effectively blow the tanker away, and time is generally too short for the FPSO to change heading dramatically. Therefore, these FPSO-initiated actions in general have limited effect and are excluded from the further modeling.

In summary, the frequency model of collision between FPSO and shuttle tanker in tandem offloading can be practically formulated as in Eq.2-2. This collision frequency model is intuitively simple, however, its applications, as discussed in the following section, form the main contents in this study.

$$P(\text{Collision}) = P(\text{PFM}) \Delta P(\text{Failure of Tanker Initiated Recovery} | \text{PFM}) \quad (2-2)$$

2.2 MODEL APPLICATIONS

To reasonably analyze and effectively reduce the occurrence of collision in tandem offloading, efforts, as implied in the above model, should be targeted on the following two stages:

1. The *initiating* stage – Identify and minimize all possible sources and situations that may cause tanker drive-off forward.
2. The *recovery* stage – Evaluate and improve the recovery actions initiated from tanker to avoid collision, should drive-off forward happen.

Note that this top-level model should not be interpreted as risk analysis and risk reduction efforts are solely directed to shuttle tanker. FPSO does play an important role in the initiating stage, contributing to a tanker drive-off forward scenario. This is revealed via studying tanker drive-off events, which is presented in Chapter 3. Findings suggest that in order to effectively reduce the probability of tanker drive-off, excessive relative horizontal motions (surging and yawing) between FPSO and tanker should be minimized. Subsequently, a simulation-based approach to quantitatively analyzing the occurrence of the excessive surging and yawing events is presented in Chapter 4. Recommendations to the design and operation of FPSO and tanker to minimize these excessive relative motion events are proposed, which ultimately may provide a sound operational condition where the initiation of tanker drive-off can be minimized.

The modeling and analyses of the tanker DP operator initiated recovery are elaborated in Chapter 5. Findings show that given the recovery strategy favored by tanker DP operators in general, the failure of recovery may be still significant due to lack of reaction time. Two principal risk reduction recommendations are then identified: one is to increase the time window (provide enough time) for the tanker DP operator to initiate recovery action; the other is to effectively reduce the operator reaction time.

The feasibility and implementation of the two risk reduction recommendations are investigated in Chapter 6 and Chapter 7, respectively. To increase the time window, a promising measure is to increase the nominal separation distance between FPSO and tanker in offloading. A brief discussion about another possible measure, i.e. to limit the forward thrust from main engine/propeller(s) that can potentially be involved in tanker drive-off, is also included. To reduce reaction time, two themes are focused on, i.e. early detection, and quick situation awareness. The findings illuminate a broad area in the human factor perspective, i.e. training, procedure, crew resource management, human-machine interface, and automation support, where measures to reduce operator reaction time may be targeted on.

3. DRIVE-OFF INITIATION

Accidents may begin in a conventional way, but they rarely proceed along predictable lines.¹

– JAMES REASON

This chapter deals with the tanker drive-off scenario. Macroscopically, the frequency of tanker drive-off forward during offshore loading, and specifically during tandem offloading, is portrayed by statistical data from an earlier study, recent SYNERGI incident data, and expert judgments made by shuttle tanker captains and DP officers. It is found that tanker drive-off forward frequency is high in tandem offloading, likely ranging from 5.4E-03 to 2.0E-02 per loading. Microscopically, the tanker drive-off forward scenario is investigated by examining 9 such events in tandem offloading based on investigation reports, interviews and discussions with individuals. Findings show that the initiation of tanker drive-off involves a complex human-machine interaction, potentially involving DP hardware and software, position reference systems and vessel sensors, local thruster control system, and DP operator. The event analyses reveal that in order to effectively reduce tanker drive-off in tandem offloading, efforts should be targeted on minimizing those failure prone situations, i.e. excessive relative motions between FPSO and tanker.

3.1 FREQUENCY OF DRIVE-OFF

Tanker drive-off event is defined in this report as: *Tanker is driven away from its target/wanted position by its own thrusters in offloading operation. This is not a planned or wanted movement.* Note in principle, drive-off can be forward, astern, or sideway, and it is the drive-off forward that may lead to collision. When “drive-off” appears in discussions below, it refers by default to “drive-off forward” unless other is stated.

Estimation of the frequency of DP shuttle tanker drive-off during tandem offloading is not straightforward. First, available and applicable data are scarce. There are few published statistical data of DP shuttle tanker drive-off frequency in offshore loadings

¹ Reason J. *Human Error*. pp.183, Cambridge University Press, 1990.

in general. Further, tandem offloading between DP shuttle tanker and FPSO/FSU in the North Sea was not carried out on a large scale until mid-1990s. Statistical data which either contains little information about tandem offloading, or hardly reflect the recent status of technical and operational systems are therefore not applicable. Second, under-reporting can be a problem. Note that a tanker drive-off event does not imply that there is a collision or other serious incident; it could turn out to be a collision near-miss under operator intervention, and subsequently it may not be reported. This was likely to be the case in the early years of tandem offloading, when the incident reporting from shuttle tankers was not as strict as it is today.

A reasonable estimation of the frequency of drive-off therefore has to be based not only on the hard statistical data (given that they do exist), but also potentially the soft data from experts' subjective judgments from their direct/indirect operational experiences. In the following sections, results derived from an earlier study made by Global Maritime for IMCA (the International Marine Contractors Association) provide some useful references to the present study. The frequency of tanker drive-off applicable to the tandem offloading operations in the North Sea in recent years (1996-2000) is estimated via two sources, namely the statistical data from the SYNERGI incident database and the expert judgments from 17 shuttle tanker captains and DP officers.

The results (based on findings in all subsections below) reveal that the tanker drive-off frequency is high in tandem offloadings, likely ranging from $5.4E-03$ to $2.0E-02$ per loading, equivalent to one drive-off in every 50 to 185 loadings. There is also evidence suggesting that the drive-off frequency in tandem offloading is significantly higher than the drive-off frequency averaged over all offshore loadings.

It is important to note that the tanker drive-off frequency results derived in this section do not refer to any specific shuttle tanker operator, nor to tandem offloadings from any specific FPSO/FSU field. These results are obtained by pooling information from a number of shuttle tankers performing offloadings from a number of FPSO/FSU fields in the North Sea, and should be viewed as representative (or sample) values applicable to the North Sea tandem offloading operations.

3.1.1 Earlier study

Global Maritime made a frequency study of shuttle tanker collision during offloading for IMCA (IMCA, 1999). This study, probably the most complete and relevant one published so far, includes all the station keeping data on tanker offshore loading operations supplied to IMCA, up to August 1998. Among these, there are 134 station keeping incidents from 9946 offloadings made by DP shuttle tankers from offshore export facilities, including FPSO/FSU fields. Most of these export facilities are believed to be located in the North Sea.

Among these 134 incidents, there are 16 forward drive-offs, which ultimately caused 12 collisions with loading point. The resulting frequencies are listed in Table 3-1.

Number of Offloading Operations: 9946	Station Keeping Incident	Drive-off Forward	Collision
Incident Number	134	16	12
Frequency (per loading)	1.3E-02	1.6E-03	1.2E-03

Table 3-1 Tanker drive-off frequency in offshore loading (IMCA data)

The above results provide a valuable statistical reference regarding DP shuttle tanker drive-off in offshore loading operations. However, one must be careful in applying these results directly to the present study. This is because of the following: First, the incidents in the IMCA data are collected from various offshore export facilities, including, but not limited to, FPSO and FSU fields. The uniqueness of the tandem offloading operation may affect the tanker drive-off frequency, and this cannot be reflected if average frequency over various offshore loading concepts is applied. Second, the IMCA data have a long time span dating back to as early as 1979, and this may not be of relevance to the present study. Again, the technical and operational systems are different in recent years compared to those of the 1980s. For the present study, the interested time span starts from 1996 when tandem offloading started to boom in the North Sea. Third, though all collision incidents are probably included in the IMCA data, near-miss data, as said in the report, are undoubtedly missing. This implies a higher actual number of drive-off(s), and subsequently a higher frequency. Practically, it is difficult to further estimate how much increase is reasonable, given the available information from that study.

3.1.2 SYNERGI incident data study

DP shuttle tanker tandem offloading incident data from the SYNERGI¹ database were collected and analyzed. The data cover the 5-year period from the beginning of 1996 to the end of 2000. In total there are 61 tandem offloading incident entries, involving 10 FPSO/FSU fields and 17 DP shuttle tankers in the North Sea, both in the Norwegian and the UK sector. Note that these incident data do not cover all FPSO/FSU fields, nor all DP shuttle tankers, in the North Sea. Therefore statistics should not be viewed as a complete picture, but rather as a reasonable sample, in regard to the tanker drive-off frequency in tandem offloadings in the North Sea.

Among those 61 incidents, there are 49 station keeping incidents, i.e. the incidents are related to propulsion (thruster, propeller, engine, generator, pitch-control device), DP system, position reference sensors, mooring system, and operation or maintenance of these systems. The remaining 12 are solely related to the loading system (green line, manifold, telemetry, etc.). Among those 49 station-keeping incidents, 7 are identified as drive-off forward (2 are drive-off astern, in addition). These 7 drive-offs ultimately caused 4 collisions with FPSO/FSU, and the remaining 3 are near misses.

¹ SYNERGI database is operated by Pride ASA. For more information, see <http://www.pride.no>

There does not exist a readily available number of how many tandem offloadings that were conducted corresponding to these incidents. Combining records and estimations made by Tveit (1998) and Tønnessen (2002), a conservative estimation is reached at 1300 tandem offloadings during this 5-year-period from 1996 to 2000. The resulting frequencies of station keeping incident, drive-off, and collision in the recent 5-year-period are listed in Table 3-2.

Number of Tandem Offloadings: 1300	Station Keeping Incident	Drive-off Forward	Collision
Incident Number	49	7	4
Frequency (per loading)	3.8E-02	5.4E-03	3.1E-03

Table 3-2 Tanker drive-off frequency in tandem offloading (SYNERGI data)

High frequencies of drive-off and collision per loading are observed from the above results. There is approximately one tanker drive-off in every 185 tandem offloadings, and consequently one collision in every 325 tandem offloadings. To put numbers in an annual perspective, an FPSO which annually has 40-50 offloadings to DP shuttle tankers may have one tanker drive-off during offloading in the order of every 5 years and one collision in the order of every 10 years.

Again, under-reporting did possibly exist, and taking this factor into account may further increase the frequency of tanker drive-off. There is only one incident entry (a collision) for the whole year of 1996, while there are 26 incident entries (including collision, near misses, safety problems) for the year 2000. The comparison of the number and also the contents of the reported incidents between the two years may reflect a possible under-reporting in the earlier years, though the number of tandem offloadings in 2000 significantly surpasses that of 1996.

By comparing to the results in Table 3-1, we may observe that the tanker drive-off frequency here is 3.3 times higher. One might conclude that tanker drive-off has occurred 3 times more frequently in tandem offloading than in all types of offshore loadings as a whole. However, we must notice the potential under-reporting in both statistical sources, which may have biased drive-off frequency numbers to a varying degree. We may further observe that for DP shuttle tankers, collision frequency in tandem offloading is 2.6 times higher than the averaged value for all offshore loadings. Unreported collision events are less likely in both statistical sources. The comparisons may consistently indicate an alarming message, i.e. that the frequencies of tanker drive-off and subsequent collision are higher (likely 3 times higher) in tandem offloading, than the averaged values of all types of offshore loadings.

It is important to notice a hidden limitation when interpreting the above frequency results. Basically, the tandem offloading operation between FPSO/FSU and DP shuttle tanker had been in continuous evolution during those 5 years. New hardware and software were designed and put into use. Operational procedures were optimized, e.g., the DP watch pattern, and more operator trainings were carried out. Moreover, the

safety awareness has been improved, as reflected by the increasing number of near misses and safety problems reported. However, the frequency numbers averaged over these 5 years (which are high in magnitude) cannot reflect the significant amount of improvements (and efforts, too) made by shuttle tanker and FPSO operators in the mean time.

Last but not least, it is worth to note the limitations in the analyses. First, the analyzed SYNERGI data only span over 5 years, and the data applicable to the study are considered no more than 6 years up to now since 1996. All in all, the applicable data are scarce. This brings statistical uncertainty to the resulting frequencies. Second, there are uncertainties connected to the estimation of tandem offloading numbers corresponding to the recorded incidents. Other independent sources that can verify the estimated loading numbers have not been found in this study.

3.1.3 Expert judgments from tanker operators

The frequency of tanker drive-off in tandem offloading is estimated via findings from a questionnaire survey concerning the tandem offloading safety. This survey, as a part of this Dr.Ing study, was conducted in the spring of 2002. A total of 17 shuttle tanker DP operators (captains and DP officers) participated in the survey. The questionnaire is attached in Appendix E.

The number of tandem offloadings and drive-offs that each operator had experienced were obtained. The drive-offs considered here include both forward and astern ones. 17 drive-off frequencies in tandem offloadings are derived. These estimations are considered independent since they are based on the operators' individual operational experience. Overall, the operational experiences from participants sum up to 1293 tandem offloadings.

The 17 estimations of drive-off frequency in tandem offloading are plotted in Figure 3-1. The averaged drive-off frequency is $8.2E-02$ per loading, and the maximum value is $3.3E-01$ per loading. These values should be handled cautiously since operators with limited operational experience may provide some non-representative values of drive-off frequency, and subsequently the average value of all estimations can be biased.

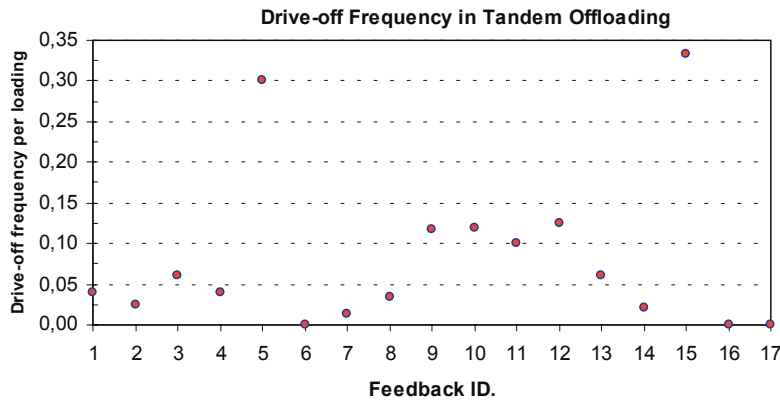

Figure 3-1 17 estimations of tanker drive-off frequency in tandem offloading

It is expected that the more loading operations are involved, the more representative is the derived drive-off frequency, since statistical uncertainty due to a limited number of operations can then be minimized. Accordingly, three groups of operators are defined with reference to the number of loadings they have performed. The drive-off frequencies are averaged for each operator group, as shown in Table 3-3.

Individual Operator Experience	Sum of Operator	Sum of Operation	Averaged Drive-off Frequency per Loading
0 < Loading \leq 50	10	430	1.2E-01
50 < Loading < 150	4	263	3.2E-02
150 \leq Loading	3	600	2.0E-02

Table 3-3 Tanker drive-off frequency estimations in tandem offloading

The averaged tanker drive-off frequencies in tandem offloading range from 2.0E-02 to 1.2E-01 per loading. The lower limit is the average from estimates by the three most experienced operators with total experiences of 600 tandem offloadings, and it implies “one drive-off every 50 tandem loading”. The upper limit is the average from estimates by 10 operators with total experiences of 430 tandem offloadings, and it implies “one drive-off every 8 tandem loading”. These frequency values are both high. The lower limit value, which is believed to have the best credibility, is still close to four times higher than the results in SYNERGI incident data study. However, we have to note that both forward and astern drive-offs are included here.

Reasonable interpretations of the results are important. The above drive-off frequency results are more in the “expert judgment” domain than in the “historical data” domain. The reasons for this are: First, one drive-off may be “experienced” both by the captain

and the officer, and subsequently would appear twice in the survey. The number of drive-offs will therefore be higher than what really happened. The same goes for the offloading operation number. Second, some operators stressed that the number of drive-offs is an approximation, not a precise record. Subjective elements are clearly involved. This may contribute to the difference between the SYNERGI incident study results and the operator estimates. We also have to take into consideration the “historical element” that is involved. That is, though the survey was conducted recently, the drive-off frequency results are derived based on operators’ *past* experiences which cannot be viewed as a direct reflection of *the present* technical system and operational configuration, nor as a fully representative *future* prediction.

3.2 ANALYSIS OF INCIDENTS

Facts and findings in Section 3.1 may have documented clearly that tanker drive-off during tandem offloading was frequent in the past. Facing the future, with more tandem offloadings to come, the important questions, at least in this study, are not to debate whether tandem offloadings by DP shuttle tankers should be banned or not, but to clarify what may go wrong that can cause the tanker drive-off, and afterwards to identify how to reduce the occurrence of tanker drive-off effectively. These are the objectives in analyzing those occurred incidents and near misses.

A study of 9 previous DP tanker drive-off events in tandem offloading is carried out, hopefully to achieve the above objectives. It is true that “studying the past may illuminate only the hazards one has passed through, rather than those that lie ahead. It is however better to see the hazards afterwards than not seeing them at all, as one may pass the same way again” (Kletz, 2001). Among these 9 tanker drive-offs, five resulted in collisions with FPSO, the remaining four were near-misses, and all happened in the North Sea between 1996 and 2001. The incident data are mainly from the investigation reports made by field operators and/or regulators. Note that an incident investigation report may be inaccurate or incomplete, even when prepared by experienced investigators. There are two difficulties for incident analysis based on written reports, as commented by Reason (1990): First, an accident report will always contain less information than was potentially available. Second, a written account has the effect of ‘digitizing’ what in originally was a complex and continuous set of ‘analogue’ events. For these reasons, interviews and discussions with the individuals that have direct or indirect information were also conducted during the study. Data are pooled together and analyzed anonymously to preserve confidentiality.

The data from each incident and near miss are coded in a tabular format which is structured according to the event development sequence. It is from these facts of what had happened that the principles of the collision frequency model presented in Chapter 2 are drawn. Each analyzed event forms a table, and 9 resulting tables are attached in Appendix B. A brief summary is presented in Table 3-4. The meaning of the terms used in the summary table is clarified below.

The initiation of tanker drive-off is structured as *Initiating Process* and *Context* at the top level. The *Initiating Process* is structured into *Link I*, *Link II*, and *Link III* based on the event development. The *Link I* refers to the traceable origin of the event chain which finally leads to the drive-off, based on the available information. The *Link II* and *III* refer to the sequential contributing events in the event chain. The events cover various technical failures and operator actions. Note that “operator actions” contributing to the initiation of drive-off are not necessarily the “operator errors”, as discussed in Section 3.3.

The *Context* addresses the circumstances during which the technical failure and/or operator action were initiated. It consists of *Weather* and *Relative Motion*. The *Weather* refers to the environmental conditions, and only incidents during which the field operational weather criteria were exceeded are counted. The *Relative Motion* refers to the relative horizontal motions between FPSO and tanker, i.e. surging, fishtailing and heading deviation, as discussed in detail in Section 3.4.

Collision Incident	Context		Initiating Process		
	Weather	Relative Motion	Link I	Link II	Link III
A	/	Surging, fishtailing	Hawser sensor	DP	/
B	/	Heading deviation	Operator Action	DP	Thruster capacity
C	/	/	PRS	Operator Action	DP
D	Above criteria	Surging, fishtailing Heading deviation	Operator Action	DP	Thruster capacity
G	/	Heading deviation	Operator Action	DP	/
Near Misses	Weather	Relative Motion	Link I	Link II	Link III
E	/	/	DP	/	/
F	/	/	CPP	Oper. Action	DP
H	/	/	DP	/	/
I	/	/	PRS	Operator Action	DP

Table 3-4 Summary of observations from 9 tanker drive-off events

The identified technical failures are listed below. This information may pinpoint those vulnerable technical areas in tandem offloading, which can also be found in more detail in other risk studies (HSE, 1997; IMCA, 1999).

- Failure of local thruster control system, e.g. pitch control failure of main controllable pitch propeller (CPP). Note that this failure mode mainly affects DP1 vessels. For DP2 vessels, two CPPs are unlikely to fail at the same time. If one CPP fails, another one will generate astern thrust to balance the forward thrust from the failed one. This is an advantage of using DP2 tanker.
- Failure of DP software and hardware. DP software bugs and controller instabilities, as happened, can initiate tanker drive-off. DP computer freezing incidents may be a frequent event, and reboot of computer solves the problem. However, DP freezing can be critical if it happens during tanker drive-off.
- Failure of position reference system (PRS). DARPS interference¹ may generate abnormal distance/heading signals, which, if accepted by DP, may cause drive-off. Further, faults in the PRS may produce a “Perfect Signal” DP, and subsequently this erroneous signal may cause the DP to reject all other correct signals. Based on wrong distance data from PRS, the DP may drive the tanker forward.
- Failure of vessel sensors. Wind sensor, hawser tension sensor, vessel draught sensor, and gyros failures may initiate a tanker drive-off. A recent tanker drive-off event happened because an erroneous wind speed generated by a faulty wind sensor was given to the “Wind Feed Forward” module in DP, and subsequently the DP initiated drive-off, though this was not in tandem offloading (Helgøy, 2002). Hawser tension sensor may also feed DP an abnormal high tension which can (and did) cause the DP to drive tanker forward.

The identified operator erroneous actions may be roughly grouped into the following three types: a) Actions due to wrong expectation of technical system function, e.g. erroneous use of DP manual bias function (however, the DP manual bias is not applicable to tandem offloading now); b) Actions due to improper use of technical system, e.g. erroneous calibration of DP mathematical model, erroneous selection of PRS; and c) Actions due to wrong assessment of internal and external situation, e.g. weather criteria and vessel positioning capability.

Regarding the *context* in which drive-off occurred, severe weather conditions only contributed to one incident. However, the relative motion is observed in four incidents. Further, these comprise four out of the five collision incidents. This implies a potential correlation between relative motion and collision.

By knowing technical failure, operator erroneous action, and context separately as above, may help to clarify “what went wrong”. However, it is not very helpful in answering the question related to the future, i.e. “How to reduce the occurrence of

¹ As a position reference system, DARPS (Differential Absolute & Relative Positioning System) carries relative position signals from FPSO to shuttle tanker. DARPS interference is caused by frequency interference with other DARPS units used in the vicinity, and abnormal relative distance and/or heading data can be produced. The shuttle tanker DP system can automatically detect and reject the abnormal position signals from DARPS.

drive-off". This question requires a detailed modeling and analyzing contributions from technical failures, operator actions and context in a joint, rather than separated, manner. In this perspective, and based on findings from this section, probabilistic modeling of tanker PFM scenario is addressed from the point of view of human-machine interaction in Section 3.3 below.

3.3 PROBABILISTIC MODELING OF DRIVE-OFF

The initiation of tanker drive-off involves a complex human-machine interaction (HMI). This is the main observation after analyzing those drive-off events. Evidences can be found from the event links (I, II, and III) in Table 3-4 and in each analyzed drive-off event in Appendix B. Subsequently, the probabilistic model of P(PFM) should not address technical events only, as did in many offshore risk studies, but also include the modeling of human actions and their interaction with technical events. This leads to the resulting probabilistic model for tanker PFM scenario as presented in Eq.3-1. Note that the term 'human actions' is used here instead of 'human errors'. This is because of the following.

Human action may cause or contribute to system failure, for example, inappropriate action, action taken at the wrong time, necessary action omitted, and so on. However, not all actions that contribute to system failure can be termed as human errors. As argued by Macwan and Mosleh (1994), whether an action is termed an error or a non-error should be defined with respect to some reference point. For example, in a nuclear power plant, turning off high pressure safety injection is an error for a loss of coolant event, while the same action is not an error for a steam generator tube rupture event. Further, in complex systems, there may be gray areas in which the distinction between error and appropriate action is unclear, for instance, when goals conflict or the operator lacks information (Murphy & Pate-Cornell, 1996).

In the occurred drive-offs, for example, the DARPS (Differential Absolute & Relative Positioning System) unit, due to interference, generated an erroneous signal and was de-selected automatically by the DP. The operator re-selected the DARPS signal into the DP as required by procedure when that signal was observed normal. However, during the re-selection process interference occurred again, and the erroneous signal due to operator's re-selection was then accepted by the DP, and subsequently drive-off was initiated based on the wrong distance calculated by the DP. It is basically not appropriate to assert that the operator's action was a human error, however, it is fair to say that the action did contribute to the initiation of drive-off.

The human actions and their interaction with technical failure events can be categorized into the following three categories in the present study. This is theoretically guided by the human reliability principles described in Appendix A (Section A.2.3), and practically based on the observations from the incidents and near misses.

1. Initiating action – An action initiates a failure event in the system.

2. Response action – An action responds to meet system demands, typically under technical failure events or special external situations. It may save or worsen the situation or cause a transition to another event.
3. Latent action – An action influences (but does not directly initiate) the technical failure, e.g. maintenance action, and/or the above two types of human actions.

Two examples excerpted from these drive-off events are briefly outlined here. They mainly serve to illustrate the above three types of human actions and their interaction with technical failures.

Incident B: Heading deviation between tanker and FPSO. The operator took manual control to align two vessels (*Response Action*). In the process, inappropriate use of DP for vessel sideways movement caused PFM (*Initiating Action*).

Incident C: DARPS got repeated failure due to interference. The operator had to react to this by re-selecting DARPS into DP (*Response Action*) when signal was observed normal again. The DARPS failure was probably due to bad maintenance (*Latent Action*). The DARPS signal likely went wrong again during the re-selection process, and due to operator's re-selection, the DP accepted the wrong distance info (not rejected the signal as it did). Based on calculated erroneous distance, the DP initiated PFM.

In the initiation of tanker drive-off, human actions can in principle be of all three types, i.e. initiating action, response action, and latent action. And the resulting probabilistic model of tanker PFM scenario is presented in Eq.3-1 below.

$$P/PFM_0 = P/PFM_1 \cdot P/PFM_2 \quad (3-1)$$

where:

$$P/PFM_1 = \frac{P/PFM | AI_i \cdot P/AI_i}{P/AI_i} \quad (3-1)$$

$$P/PFM_2 = \frac{P/PFM | AR_k, TF_j \cdot P/AR_k | TF_j \cdot P(TF_j)}{P/AR_k | TF_j \cdot P(TF_j)}$$

$P(TF_j)$	Probability of technical failure j
$P(AR_k TF_j)$	Probability of human response action k conditioned on technical failure j
$P(PFM AR_k, TF_j)$	Probability of powered forward movement conditioned on human response action k and technical failure j
$P(AI_i)$	Probability of human initiating action i
$P(PFM AI_i)$	Probability of powered forward movement conditioned on human initiating action i

The first type of human action, i.e. the initiating action, can directly initiate a tanker PFM scenario. It is modeled by P/PFM_1 in Eq.3-1.

The second type of human action, i.e. the response action, may interact with technical failures to initiate a tanker PFM scenario. It is modeled by P/PFM_2 in Eq.3-1.

In a narrow sense, the third type of human action, i.e. the latent action, may be viewed as the human action that influences the technical failure probability, e.g. during the maintenance. This type of human action is not included in the probabilistic model of the PFM scenario in Eq.3-1. It is more suitable to address this issue in a dedicated components risk study, e.g. CPP failure study (IMCA, 1995). It is also believed that the failure rates for components largely have included this type of human action contribution.

However, in a broader sense, the latent human action has a vast span in terms of time and contents. It may occur in design, construction, installation, operation and/or maintenance. It may interact not only with technical failure, but also with the other two types of human actions. In isolation, it may not be enough to initiate an event, and subsequently it can lie in the system for a long time before it strikes. Modeling of the latent action therefore has to be based on an organizational approach, i.e. we have to not only consider front-line operators, but also include maintenance personnel, management teams, company safety culture, and so on. This is a research challenge. Whether or not the probabilistic modeling can capture the subtle interdependency relationships between various factors at various levels for a dynamic (not static) organization is a problem yet to be clarified. Therefore, in this study, latent human action as a whole is not included in the probabilistic model. For further information about latent human action in an organizational perspective, see Reason (1997).

3.4 QUANTIFICATION – FAILURE PRONE SITUATIONS

The probabilistic model (Eq.3-1) for the tanker PFM scenario in the initiating stage is *apparently* elegant, e.g. this model incorporates not only the PFM scenarios that are rooted in human initiating actions, but also those that are rooted in technical failures which interact with human response actions. However, knowing the above model does not directly offer much insight into the practical world regarding how to effectively prevent drive-off initiation in tandem offloading.

A traditional way to proceed is to perform quantifications of the proposed $P(PFM)$. In principle the work will involve evaluating the following three terms according to the model: technical failures, human response actions that interact with technical failures, and human initiating actions. The technical failures identified in this study (Section 3.2) may have their failure rates derived from various offshore risk studies, e.g. IMCA (1995) and DPVOA (1994). However, identification and subsequent quantitative evaluation of human initiating and response actions are not easy to achieve. Qualitative models, e.g. in operational HAZOP studies, may exist and are effective for the purpose of identification. For quantification purpose, expert judgment may be the only choice in practice. Information of expert judgment techniques and their application in offshore quantitative risk analysis may be found from Hokstad et al. (1998), Skjong and Wentworth (2001), and Gudmestad (2001). However, comparison and integration of

probabilities generated from different domains, i.e. historical technical data and subjective human action data, can be problematic. The difference in scale regarding drive-off frequencies estimated by statistical data and the expert judgments in Section 3.1 can serve as an example. This may lead to practical difficulties to identify where to target the effective risk reduction efforts, even if quantifications are somehow magically achieved.

Quantification is difficult, however, it is even more difficult to know what to quantify. The above outlined quantification efforts are likely futile, while a promising way forward is identified via examining (and later quantifying) the *context* in which technical failures and human actions occur. This is, in spirit, inspired by the Error Prone Situation (EPS) concept proposed by Fujita (1992). Technical failures are generally considered random, however, there are exceptions. For example, in high-pressure weather, DARPS interference often occurred. The high-pressure weather can be viewed as a failure prone situation for DARPS units (though in this case we cannot do much about the weather). Human actions are based on situations and how these situations, including technical failures, are recognized, i.e. they are situation dependent rather than completely random.

Technical failures and operator actions did not occur in random situations, but mostly in the situation when relative motions between tanker and FPSO in horizontal plane were excessive. This is found from the incident analyses, particularly from those occurred collision incidents. Near misses were generally investigated in a much superficial level and available information then offers little trace of the context. Four out of five collision incidents actually were resulted from drive-off(s) which happened when relative motions were excessive. It is during one or several combined modes of these excessive relative motions that a human-machine interaction process was initiated, e.g. by a technical failure event or an operator action (not necessarily an erroneous one), and the human-machine interaction eventually led to tanker drive-off. The overall event development is schematically illustrated in Figure 3-2.

These evidences point out the failure prone situation in tandem offloading, i.e. excessive relative motions in the horizontal plane between FPSO and tanker. A closer examination of these excessive relative motions reveals that there are two dominant motion modes, namely the surging, which occurs due to surge motions of the two vessels; and the yawing, which includes heading deviation and fishtailing motions of the two vessels. Under excessive surging and/or yawing, a number of failures may happen (or have happened). For example, the main CPP may fail since there is a frequent pitch shift from astern to ahead. The tanker may lack enough thruster capacity to maintain a sound heading, i.e. heading deviation occurs, and operator may take manual control to align heading. Subsequently, erroneous action may be made, or technical failure may occur, so that tanker drive-off is initiated. This exemplifies, as pointed out by Reason (1990), that “accidents may begin in a conventional way, but they rarely proceed along predictable lines.” A more systematic and detailed explanation of hazards caused by surging and yawing can be found in Chapter 4.

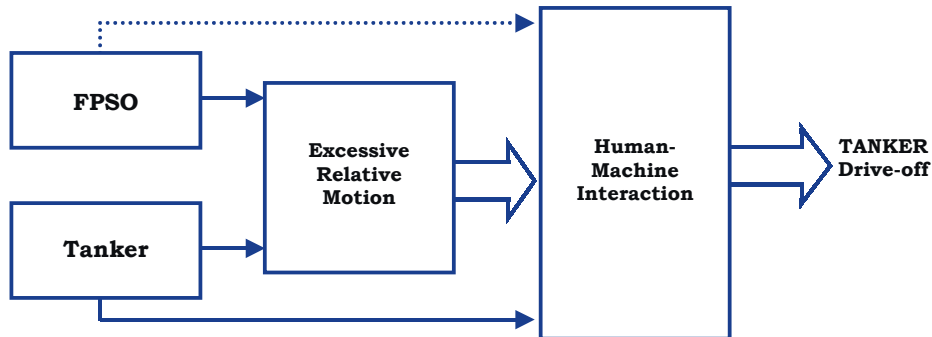

- Four out of five collision incidents actually resulted from drive-offs which happened when relative motions were excessive.
- The remaining collision incident resulted from a drive-off that had nothing to do with the excessive relative motion. The man-machine interaction that led to the drive-off was originated from a technical failure of one position reference unit on the tanker (ultimately may be viewed from FPSO's failed gyro). This is reflected by the dashed connection lines between "FPSO" and "Man-Machine Interaction" in the figure.
- There are also near miss collisions in which the man-machine interaction that led to the tanker drive-off was initiated by the tanker's local technical system, e.g. a failed main controllable pitch propeller. This is reflected by the connection line between "Tanker" and "Man-Machine Interaction" in the figure.

Figure 3-2 Illustration of tanker drive-off initiation (based on 5 collision incidents)

To conclude this chapter, risk reduction efforts should urgently be directed to minimize the occurrence of excessive surging and yawing events. These are failure prone situations in tandem offloading. Doing so will hit the bottom of tanker drive-off, and it will hit hard. The surging and yawing are influenced by a number of factors, e.g. the environmental condition, technical system capacity, configuration, operational philosophy, and so on. Quantitative studies of these failure prone situations are carried out in this Dr.Ing study by simulating motions between FPSO and tanker. This is presented in Chapter 4.

4. SURGING AND YAWING

Accident prevention is both science and art. It represents, above all other things, *control* – control of man performance, machine performance, and physical environment.¹

– H. W. HEINRICH

Excessive relative motions between FPSO and tanker, categorized in surging and yawing modes, have been identified in Chapter 3 as the failure (drive-off) prone situation in tandem offloading. This chapter presents a study aimed at quantitatively assessing and effectively minimizing the occurrence of excessive surging and yawing events.

The approach is built on a state-of-the-art time-domain simulation code SIMO. The simulation models are setup and calibrated mainly based on full-scale measurements for a typical North Sea FPSO and a DP shuttle tanker. The calibration work and the time-domain simulation theory used in SIMO are documented in Appendix C. The simulated relative distance and relative heading between FPSO and tanker are analyzed by fitting their extreme values into statistical models which then give out probabilities of excessive surging and yawing events. Sensitivity studies are performed to pinpoint contributions from various technical and operational factors. Findings indicate that excessive surging and yawing events can be effectively minimized via three principal measures; i.e. minimizing FPSO surge and yaw motions in offloading, coordinating mean heading between FPSO and tanker, and using the dedicated DP software with the tandem loading function on tanker. Ultimately, these measures may provide a sound operational environment where the possibility of tanker drive-off can be minimized.

4.1 INTRODUCTION

Surging refers to the relative surge motion between FPSO and tanker. The surging becomes a problem when the two vessels oscillate fore and aft in an asynchronous manner, i.e. the FPSO moves astern at the same time as the tanker moves ahead, as illustrated in Figure 4-1.

¹ Heinrich HW. *Industrial Accident Prevention*. 4th Ed., pp4, McGraw-Hill Book Company, Inc., 1959.

Surging may lead to a rapid change of separation distance between tanker and FPSO. In order to maintain a wanted separation distance, tanker will try to ‘follow’ the FPSO movement. This is generally the case if tandem offloading is performed in DP mode, and the DP software has no dedicated tandem loading function (See Appendix D for details of this special DP function.). The situation then requires a relatively rapid change of tanker propulsion force between ahead and astern. This is a very “stressed” condition for the tanker main propeller pitch control system. Failure may occur, e.g. failure of pitch shift from ahead to astern, and it then leads to tanker drive-off. The situation may also get worse by response time lag due to the big inertia of a tanker.

One incident may vividly illustrate the danger of surging, which was described by a shuttle tanker captain during an interview (Chen, 2001) regarding the tandem offloading safety. This incident happened in a marginal environmental condition (in which tanker probably should not have been in connection). The FPSO surged astern. This made the tanker move backwards. While at a time when the FPSO started to surge ahead, the tanker was still moving backwards. This made the separation distance significantly longer than the mooring hawser and loading hose can sustain, and both lines were parted in a very short time.

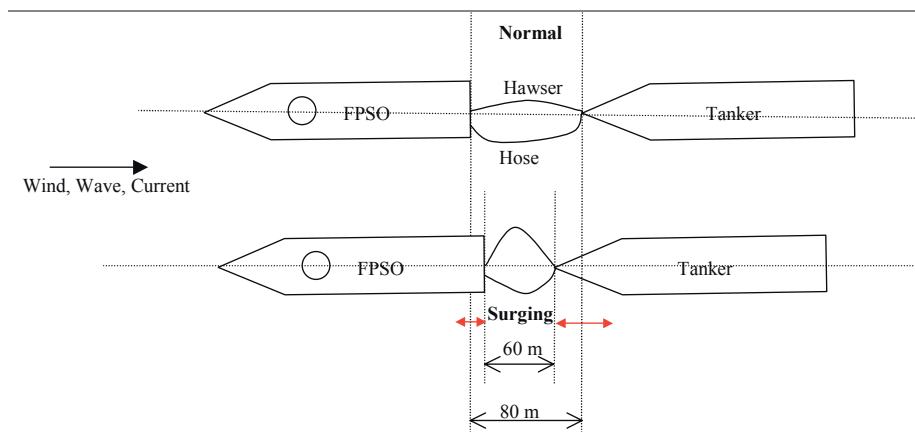

Figure 4-1 Surging illustration

Yawing refers to the relative yaw motion between FPSO and tanker. Both mean and instantaneous values of yaw motion are considered here. The former is often called heading deviation, and the latter fishtailing. Yawing is resulted from the different weathervane characteristics between FPSO and tanker, and it becomes a problem when a significant difference of mean headings is developed, and worsened by asynchronous yaw motion between the two vessels, as shown in Figure 4-2.

Yawing, and specifically the heading deviation, could in principle result in loss of relative position reference signals between tanker and FPSO. Moreover, tanker DP officer may have to perform a difficult maneuvering of the tanker in close distance to the FPSO to correct the heading deviation, if the FPSO does not (or cannot) adjust the

heading to fit in with the tanker. Typically, with a limited sideway thruster capacity, the tanker DP system may initiate forward pitch from main propulsion and use rudder to provide the necessary turning moment. This can cause tanker drive-off.

The following collision incident, which happened in the North Sea (Statoil, 2000), is briefly outlined to exemplify the danger of yawing. At the final stage of loading, tanker had a significant heading difference (about 24°) to the FPSO. To align the tanker with the FPSO, which is a necessary operation to send back the hose, the tanker DP operator took action to maneuver the vessel. In a combination of technical failure and inappropriate DP operation, a drive-off was initiated, which ultimately resulted in a collision.

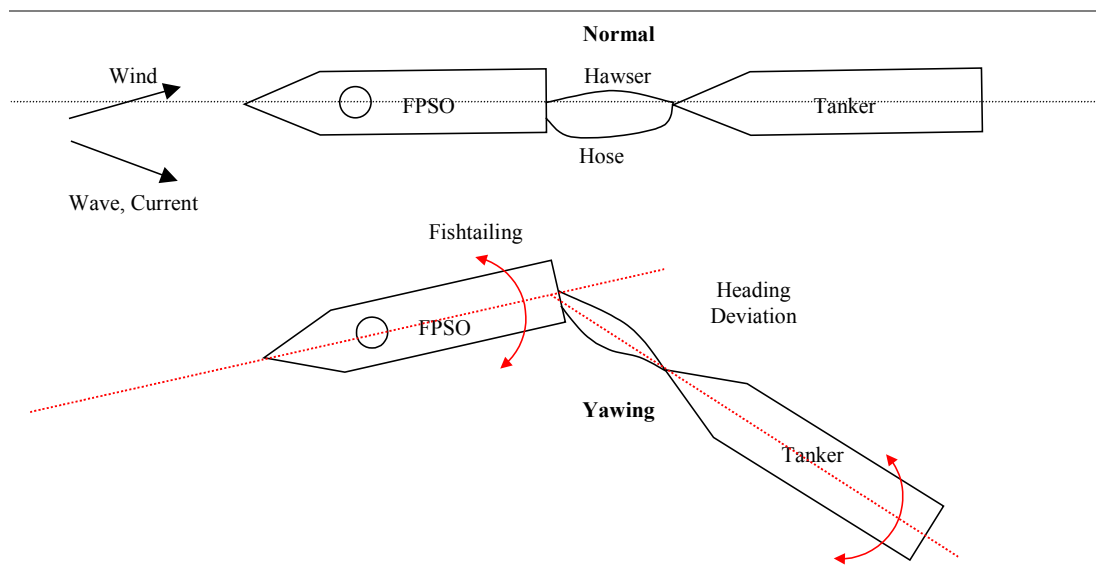

Figure 4-2 Yawing illustration

There are very limited offshore QRA studies that have addressed the excessive surging and yawing events in tandem offloading operations. For those studies that have included the risk modeling of these events, expert judgment is a typical approach. The occurrence probabilities of excessive surging and yawing are estimated by a group of experts, and event development after these two basic events is modeled. However, this approach may not offer much information about how to reduce the occurrence of the two basic events. At best, qualitative measures may be identified based on the experiences of the experts involved.

Given the status described above, a systematic approach to predict the occurrence of excessive surging and yawing and consistently minimize their occurrence is clearly needed. The approach adopted in this Dr.Ing study is based on time-domain motion simulations of a joint FPSO-tanker system, as described in the following section.

4.2 SIMULATION-BASED APPROACH

4.2.1 Feasibility

To study the occurrence of excessive surging/yawing events and minimize their occurrence, a simulation-based approach needs to fulfill the following two conditions:

1. A validated time-domain motion simulation tool that is capable of simulating horizontal motions of an FPSO and a DP shuttle tanker connected in a tandem configuration, under possible operational environments.
2. Calibrated FPSO and tanker simulation models (for the use in above tool) that can reasonably simulate the physically occurred two-vessel horizontal motions.

Several numerical simulation studies of joint FPSO and tanker responses under wave, wind and current are available in recent publications. For example, relative motion is investigated by Inoue and Islam (1999) for parallelly connected LNG and FPSO units in waves. Morandini et al. (2001) outline the specific problems associated with the offloading operations, and present a simulation study of tandem offloading in taut hawser configuration. Morishita et al. (2001) studied the dynamic behavior of tandem vessels under wind and current forces. The directional stability of a converted FPSO (from VLCC) and a tanker is investigated by Sphaier, et al (2001). However, these tools may not be directly applied to the present study due to the following reasons.

Tandem offloading carried out by DP shuttle tankers in harsh North Sea environments is considered in the present study. Thus wind, wave, and current should all be included in the simulation. Further, the FPSO is a purpose-built vessel which has DP capability. Depending on operational strategies, the FPSO may be operated to a preferable heading and may use its DP-operated thrusters to dampen down both surge and yaw motions. Operational alternatives on the tanker also exist, e.g. different DP software and DP operational modes. In short, natural, technical, and operational factors all potentially affect the surging and yawing events. These influencing factors should be reasonably baked into the time-domain motion simulation.

To fulfill the first condition, the time-domain motion simulation code SIMO developed by Marintek appears to be a suitable candidate. The SIMO code has been developed and continuously upgraded in the past decade. The method SIMO uses has been validated by model tests and studies carried out at Marintek. SIMO has also been involved in motion simulation studies of turret moored FPSOs, e.g. by Fylling et al. (1992) and Ormberg and Larsen (1998). The numerical methods used in SIMO are briefly presented in Appendix C. More references are found in Reinholdtsen and Falkenberg (2001).

To fulfill the second condition, simulation models of a typical North Sea purpose-built FPSO and a DP shuttle tanker are set up in SIMO. The joint two-vessel model is calibrated based on model tests (Marintek, 1994 & 1999) and full-scale motion

measurements (Andersen, 2000; Blom, 2002) before being applied to the study of surging and yawing.

4.2.2 Procedures

The simulation procedures for analyses of surging and yawing in tandem offloading are formulated with the following two objectives in mind:

1. To predicate the likelihood of the excessive surging and yawing; and
2. To pinpoint contributions from various technical and operational factors, and identify measures to reduce the occurrence of such events in the operation.

These two objectives may be different from traditional applications of time-domain motion simulations, e.g. mooring and riser system analyses and thruster consumption studies, in the sense that the interested parameters are the relative distance and the relative heading between the two vessels. Specifically, given the objectives and what the SIMO code actually can perform, simulations of surging and yawing are structured in the three steps described below.

First, the offloading operation is simulated for three hours. Note that the whole operation may take well above twenty hours. The three-hour simulation is considered as a “sample of operation”, through which we are able to pinpoint which factors (in technical and operational categories) have contributed to the occurrence of surging and yawing.

Second, the three-hour time-domain simulation is performed twenty times with random seeds for generating time series of wind and wave. The simulated relative distance (tanker bow to FPSO stern mooring point) and relative heading between FPSO and tanker are analyzed by fitting their extreme values (from 20 simulations) into the statistical models, i.e. the first type extreme value distribution. The fitted distributions are used to assess the occurrence probability of excessive surging and yawing events.

Third, a marginal operational weather condition is selected in simulations. Sensitivity studies are performed to analyze contributions from various technical configurations and operational philosophies this weather condition. Various environmental conditions, given that the weather criteria are satisfied and thrust demands on both vessels are within their thruster capacity limits, mainly influence thruster power consumption, and have limited influence on vessel motions. This is because the dynamic positioning control in the operation keeps vessel motions in a similar order of magnitude under various weather conditions, as can be observed from the full-scale FPSO and tanker motion measurements (Andersen, 2000; Blom, 2002). Therefore, the present study does not include the environmental sensitivity.

4.2.3 Limitations

It is also important to notice the following limitations in the simulation-based approach at present. Basically, the simulation work is carried by SIMO, and this program itself has idealizations, for example, in the modeling of the DP control system. However, given the calibration work performed, those program idealizations do not change the main conclusions in this study. Regarding the simulation model, further work is needed to take the following into account.

The thruster power limitations on both the FPSO and the tanker are not considered, i.e. both vessels have abundant positioning capacities. Subsequently, the environmental impact on vessel motion behavior is considered small and not studied in the present sensitivity studies. However, in actual operation there are positioning capacity limitations, especially on the tanker side. Environmental conditions, such as collinear vs. non-collinear wind-wave-current, abnormally large current, and etc., will inevitably influence the surging and yawing events.

Weather is assumed stable (i.e. no weather change) during the three-hour simulation. Therefore scenarios involving for example a sudden wind change, will not be included. In such cases, the FPSO may start to change heading, and the tanker has to follow. During the transition period to the next equilibrium (stable) condition, yawing might be a problem. Alternatively if the FPSO keeps heading, the tanker may be “drifted” to a new heading by the changed environmental forces. In that case, significant yawing (heading deviation) may be developed in a short time.

The draught changes of FPSO and tanker during the 3-hour simulation (and subsequent changes of two vessels’ hydrodynamic coefficients) are not incorporated in the present simulation model. In principle, this could be done by making a number of simulation models and simulate motions respectively, e.g. ballast FPSO + fully loaded tanker, and vice versa. The hydrodynamic interactions between FPSO and tanker, e.g. the shadow effect (Fucatu et al. 2001) of wind and current from FPSO on tanker, are not included in the simulation.

4.3 VESSEL MODELS

The two vessel models in simulation of tandem offloading are illustrated in Figure 4-3.

The FPSO is a purpose-built vessel for operation in the North Sea. The FPSO model in SIMO consists of hull and positioning system. The main particulars of the vessel are listed in Table 4-1. The hydrodynamic data for the FPSO hull are synthesized by results from WADAM¹ calculations, model tests, and calibration work. Detailed data and their sources are listed in Table 4-2. Note that these FPSO data are for a medium draught loading condition.

¹ WADAM is a general hydrodynamic analysis program for evaluating wave-structure interaction. It is a part of SESAM software developed by DNV. For general information, see <http://www.dnv.com/software>.

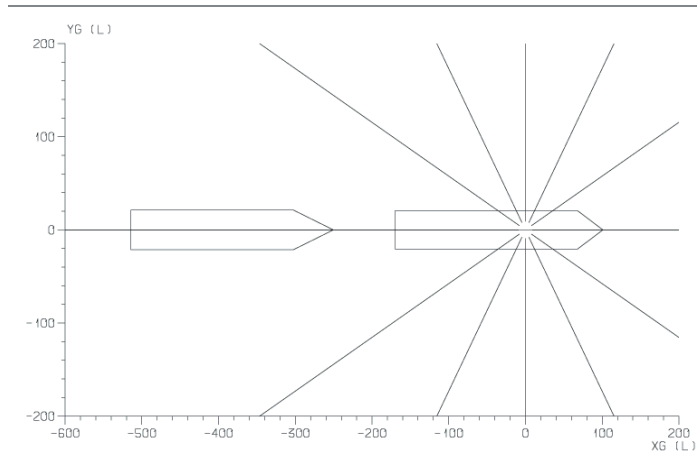

Figure 4-3 Vessel models in tandem offloading simulation

The positioning system of the FPSO consists of an internal turret mooring system, three DP operated thrusters, and a DP control system. There are twelve equally spaced catenary mooring lines. Each mooring line is a combination of chain and wire rope, and the breaking strength is 10000 kN. Three azimuth thrusters are modeled as an approximation to the five real life thrusters, one bow thruster (860 kN) and two stern thrusters (430 kN and 860 kN, respectively). The FPSO DP system is modeled by a PID Controller in SIMO, which is based on conventional PID control theory (Reinholdtsen and Falkenberg, 2001). Geo-stationary reference position and reference heading are specified for vessel offset and heading control operations.

The tanker is a North Sea DP2 class shuttle tanker. It is positioned 80 m behind the FPSO in DP mode. Similar to the FPSO model, the tanker model in SIMO consists of hull and positioning system. The hull data of the tanker are listed in Tables 4-1 and 4-2. Note that these tanker data are for a deep draught loading condition.

The tanker positioning system in principle consists of bow and stern thrusters, main propellers and rudders, the DP control system, and the hawser. The hawser is modeled as a non-load bearing soft spring which has tension of around 20 kN due to self-weight. The thrusters, main propellers and rudders are modeled in SIMO with an idealization based on information from the DP system designer (Gudmestad and Aanonsen, 2001). One bow azimuth thruster (620 kN) and one stern tunnel thruster (190 kN) are modeled. For simplicity, the possible thrust generated by the combination of two rudders and two main propellers are modeled by one fictitious azimuth thruster (770 kN) at stern. Similar to the FPSO model, the tanker DP system is modeled by the PID Controller in SIMO. It is possible in SIMO to use the moving FPSO stern and heading as the positioning references for the tanker, in addition to the geo-stationary references. This makes simulation of different DP software and various DP operational strategies used on the tanker in tandem offloading possible.

Main Particulars	FPSO	Tanker
Length (m)	260	265
Breadth (m)	41	42.5
Depth (m)	25	22
Draught (m)	15.5	14
Max. Draught (m)	19	15
Mass (Mg)	119,600	112,000

Table 4-1 Main particulars

Hydrodynamic Data: FPSO and Tanker Hull	Sources
Mass (6 d.o.f.)	Model test
Added mass (zero frequency)	WADAM
Damping (mooring, hull, wave drift) Damping (DP thruster)	Model test, empirical estimation Calibration
Hydrostatic stiffness matrix	WADAM
1 st order motion transfer function (6 d.o.f)	WADAM
2 nd order wave drift force coefficient (3 d.o.f)	WADAM
Wind force coefficient (3 d.o.f)	Wind tunnel test
Current force coefficient (3 d.o.f)	Model test

Table 4-2 Hydrodynamic data

To calibrate the vessel models so that motions simulated are physically reasonable is an important task. In this study, full-scale measurements of the horizontal motions of an FPSO and a DP shuttle tanker during offloading are obtained, and used for the model calibration work. Given its length and contents and the overall theme in this chapter, the calibration work is elaborated in detail in Appendix C. The conclusion made after the calibration is that the present two-vessel model is able to reasonably simulate the physical horizontal motions between FPSO and tanker in offloading.

4.4 ENVIRONMENTAL CONDITIONS

The environment used in simulation is close to the operational limit. Mild and medium environmental conditions in tandem offloading are not included at present. The marginal operational environment is modeled based on information from onboard measurements during offloading operation (Andersen, 2000) and supplemented with hindcast data from the Norwegian Meteorological Institute (DNMI, 2000).

The wave is modeled as an irregular short-crested wave by a three-parameter JONSWAP spectrum with a *cos* spreading function. The wind is modeled by a one-hour mean wind speed plus a NPD gust spectrum. Note that neither measurement nor hindcast includes current data. Therefore the current velocity profile and direction are based on simple assumptions, i.e. the current is mainly the wind- and wave-generated current. According to the DNV Class Note 30.5 (1991) the wind- and wave-driven current may be estimated as 1.5 % of the wind speed. The current direction is ideally

assumed to be close to the wind and wave directions, i.e. propagating 180° relative to the mean FPSO heading. The swell is possible to model based on hindcast information. However, it is disregarded due to the present SIMO limitation, i.e. the swell affects only high-frequency (HF) motion in simulation, while the low frequency (LF) motion is the main interest in this study.

The resulting wind, wave, and current data are summarized in Table 4-3 together with their sources. The wind, wave and current directions are further illustrated in Figure 4-4.

Environmental Parameters		Sources
Significant wave height (m)	5.4	Measurement
Peak period (sec)	12.6	Hindcast
Spectrum	JONSWAP	Assumption
Wave direction ¹ (deg)	171°	Hindcast + Assumption
Wind speed ² (m/s)	16.3	Measurement
Wind direction (deg)	-174°	Measurement
Current velocity (m/s)	0.24	Assumption
Current direction (deg)	180°	Assumption

Table 4-3 Offloading environmental condition

Last but not least, as a sample of operation, the above vessel configuration and environmental condition reflect the following operational picture: The tanker has been loading from the FPSO to take part of its storage, and the operation is approaching the end. So the FPSO and tanker are in medium and fully loaded conditions, respectively. Meanwhile, weather is deteriorating, and close to (but within) the operational limits.

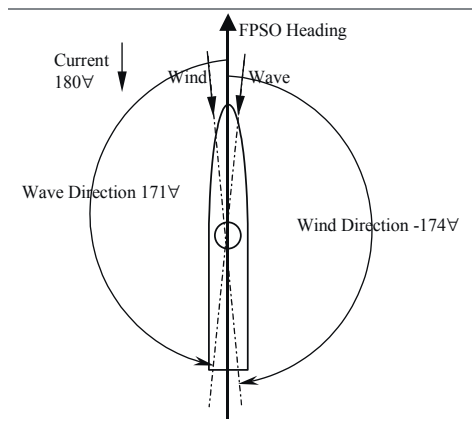

Figure 4-4 Wind, wave and current directions in simulation

¹ Direction definition is illustrated in Figure 4-4.

² Wind speed was measured as 20-minute mean value on board, and then converted to one-hour mean value based on NORSOK (NTS, 1999).

4.5 BASE CASE RESULTS

The base case FPSO and tanker configuration is described below. This case may reflect the “best practice” adopted in the tandem offloading in the North Sea. The moored FPSO actively reduces its surge and yaw motion amplitudes by providing damping via DP thrusters. The FPSO mean heading is controlled by DP thrusters too, and it is selected as the optimum heading in weathervane, i.e. the resultant environmental force direction. The tanker, which is positioned 80 m behind the FPSO, uses a geo-stationary motion control window around the mean FPSO stern hawser terminal point as its position reference, i.e. the tanker does not follow a moving FPSO stern point instantaneously. Details of this special window function in DP software can be found in Appendix D. The tanker heading is actively aligned with the mean heading of FPSO. The tanker also actively reduces its motion amplitudes in surge and yaw by providing damping via DP thrusters.

The motion behavior of above two-vessel configuration is studied by twenty 3-hour simulations with different random seeds for generating time series of wind and wave. Based on mean and standard deviation of simulated extreme values, the minimum separation (bow-stern) distance X and maximum heading difference χ between the two vessels are fitted into the first type extreme value distributions, via which the probabilities of excessive surging and yawing events are obtained. The fitted distributions are presented in Eq.4-1 and 4-2 for X and χ , respectively.

$$P_{\min} / X | 0 | \exp \left[4 \exp \left[\frac{X - 76.22}{0.6523} \right] \right] \quad (4-1)$$

$$P_{\max} / \chi | 0 | \exp \left[4 \exp \left[\frac{\chi - 5.277}{0.5602} \right] \right] \quad (4-2)$$

To facilitate the quantitative discussion below, the excessive surging event is defined as the minimum separation distance between tanker and FPSO smaller than 60 m, i.e. a 20 m reduction of nominal separation distance. Similarly, the excessive yawing event is defined as the maximum heading difference between the two vessels larger than 20°. Accordingly, the base case probabilities for excessive surging and yawing events are presented in Table 4-4.

Excessive Surging in 3-hour simulation	Probability (per 3-hour)
Min. Separation Distance < 60 m	1.59E-11
Excessive Yawing in 3-hour simulation	Probability (per 3-hour)
Max. Heading difference > 20°	3.86E-12

Table 4-4 Base case surging and yawing probabilities

The results in Table 4-4 show that in the base case, excessive surging and yawing event probabilities are negligible. A number of technical and operational factors have

contributed to these good phenomena, and their contributions are analyzed in the following sensitivity studies. Furthermore, we have to make note of the fact that when an operation is repeated frequently, it is the very low probabilities that are of main interest in the risk analysis.

4.6 SENSITIVITY STUDIES

The following assumptions are introduced in the sensitivity studies. In the surging event study, we assume that both vessels use the same heading and yaw motion control as in the base case. Similarly in the yawing event study, we assume that both vessels use the same position reference and surge motion control as in the base case. This is because a floating vessel's surge and yaw motions are correlated. With different vessel mean headings, the environmental forces acting on the vessel are different, and subsequently different surge mean values and amplitudes will occur. The above assumptions are therefore to minimize this correlation.

4.6.1 Surging and contact events

The following three factors that influence the surging event are identified.

1. How the tanker positions itself relative to the FPSO, i.e. use a geo-stationary motion control window around the FPSO stern hawser terminal point, or a moving FPSO stern point, for horizontal position reference. Note that in both cases the mean separation distance is maintained around 80 m.
2. How the FPSO controls its surge motion, i.e. whether or not the FPSO uses its DP thrusters to dampen down the surge amplitude.
3. How the tanker controls its surge motion, i.e. how much surge damping the tanker thrusters are able to provide to dampen down the surge motion amplitude.

Note that the first and second factors may be influenced by design or by operational strategy. For example, some FPSOs may only have one or two stern thrusters installed for heading control. Its surge motion can only be restrained by the turret mooring system. In other cases, the control room operator on FPSO may not use thrusters to reduce the surge motion amplitude, even though enough thruster capacity is available. Similar situations exist regarding the motion window function in tanker DP software, i.e. no installation, or installed but no utilization. For the third factor, ideally it should be investigated in the base case and then in each sensitivity case for various tanker surge damping levels. This will increase the number of simulations significantly. However, the comparison between the base case and the sensitivity cases should be made with the same tanker surge damping level. The base case results in Table 4-4 imply that tanker has effectively dampened down its surge motion. Therefore, for simplicity, the third factor is assumed constant, i.e. the tanker surge damping provided by thrusters remains same in all sensitivity cases as in the base case.

According to the first and second surging influencing factors, three surging sensitivity cases are formulated in Table 4-5.

Tanker position reference	FPSO surge motion control	
	With Surge control	Without Surge control
Geo-stationary motion window	<i>Base case</i>	<i>Surging Case 2</i>
Following FPSO stern	<i>Surging Case 1</i>	<i>Surging Case 3</i>

Table 4-5 Surging sensitivity case configurations

As in the base case, twenty 3-hour simulations are performed for each sensitivity case, and the simulated minimum separation distance values are fitted into the first type extreme value distribution. The probabilities of surging events are then obtained. Values corresponding to the excessive surging event are presented in Table 4-6.

Surging Sensitivity	Probability of excessive surging in 3-hour simulation	$P_{\min} / X0 14 \exp \left[4 \exp \left[\frac{X 4 \sigma}{\omega} \right] \right]$	
		σ	ω
Base Case	1.59E-11	76.22	0.6523
Surging Case 1	1.00E-9	75.56	0.7509
Surging Case 2	1.36E-6	74.64	1.084
Surging Case 3	3.16E-5	72.27	1.184

Table 4-6 Excessive surging event probabilities

The contribution from the first factor, i.e. how the tanker positions itself relative to the FPSO, is shown by a comparison between the *base case* and *surging case 1*, as well as between *surging case 2* and *surging case 3*. The probability of surging can roughly be decreased 10^{-10^2} times if the tanker uses a geo-stationary window instead of a moving FPSO stern point as the position reference. The contribution from the second factor, i.e. how the FPSO controls its surge motion, is shown by a comparison between the *base case* and *surging case 2*, as well as between *surging case 1* and *surging case 3*. The probability of surging may increase 10^4 - 10^5 times if the FPSO does not use thrusters (or does not have enough thruster capacity) to dampen down its surge motion.

By a comparison between the *base case* and *surging case 3*, the probability of excessive surging increases 10^6 times, and it is not as negligible as in the base case. Practically the result reflects the difficulties of tandem offloading in a situation where the tanker uses a moving FPSO stern point as the position reference, and the FPSO has a large surge motion.

The contact event can be defined as a minimum separation distance between the FPSO and tanker smaller than zero. The probability of contact, derived from the above minimum separation distance distributions, is virtually zero for the base case and all three sensitivity cases. This implies that a collision between FPSO and tanker caused by a very excessive surging event alone is not possible, i.e. excessive surging does not directly cause contact between FPSO and tanker.

4.6.2 Yawing events

The following three factors that influence the yawing event are identified:

1. How the FPSO and tanker position their mean headings relative to each other, i.e. coordination of mean heading with each other, or weathervane individually.
2. How the FPSO controls its yaw motion, i.e. whether or not the FPSO uses its thrusters to reduce the yaw motion amplitude.
3. How the tanker controls its yaw motion, i.e. how much yaw damping that tanker thrusters are able to provide to reduce the yaw motion amplitude.

Similar to the surging sensitivity study, the first and second factors may be influenced by design or by operational strategy. The third factor is again assumed constant, i.e. the tanker yaw damping provided by thrusters remains same as in the base case in all sensitivity cases. According to the first and second factors, the two yawing sensitivity cases are formulated in Table 4-7.

	FPSO mean heading control	
Tanker mean heading control	Weathervane heading	Heading on the wind ¹
Align with FPSO mean heading	<i>Base Case</i>	/
Weathervane with own interest ²	/	<i>Yawing Case 1</i>
	FPSO yaw motion control	
Tanker mean heading control	With yaw control	Without yaw control
Align with FPSO mean heading	<i>Base Case</i>	/
Weathervane with own interest	/	<i>Yawing Case 2</i>

Table 4-7 Yawing sensitivity case configurations

Note that when studying the mean heading control in *yawing case 1*, the same FPSO yaw motion control is assumed; while similarly the same FPSO weathervane mean heading is assumed when studying the yaw motion control in *yawing case 2*. In practice, however, FPSO mean heading and yaw motion are controlled by a single heading control function in the DP system. The differentiation made here is an idealization in order to pinpoint the relative contributions from the first and second influencing factors.

Based on twenty 3-hour simulations, the probabilities of the yawing events and the first type of extreme value distribution parameters are obtained. Excessive yawing event probabilities are presented in Table 4-8.

¹ This reflects one possible FPSO heading operational strategy likely demanded by the production needs.

² Tanker DP system determines the optimum weathervane mean heading.

Yawing Sensitivity	Probability of excessive yawing in 3-hour simulation	$P_{\max}/\chi^2 \exp\left[4 \exp\left[4 \frac{\chi^4 \sigma}{\omega}\right]\right]$	
		σ	ω
Base Case	3.86E-12	5.277	0.5602
Yawing Case 1	3.04E-07	15.05	0.3299
Yawing Case 2	6.18E-05	12.80	0.7431

Table 4-8 Excessive yawing event probabilities

The contribution of the first factor, i.e. how the FPSO and tanker position their mean heading relative to each other, is shown by a comparison between the *base case* and *yawing case 1*. The probability of an excessive yawing event is significantly increased (10^5 times higher than in the base case) to a non-negligible level. These results illuminate the importance of joint mean heading operation between FPSO and tanker. In the given environmental condition, the tanker's weathervane mean heading is about 6° different from the FPSO's weathervane mean heading. If the FPSO has to be headed on the wind, the mean heading difference between the two vessels further increases to 12° . We may further infer from the simulation results that under certain environmental condition, the tanker's weathervane mean heading is potentially very different (e.g. 20° or 25°) from the FPSO weathervane mean heading. If there is no mean heading coordination between the two vessels, excessive yawing events (i.e. 20° heading difference) may occur several times even in one single offloading operation.

The contribution of the second factor, i.e. how the FPSO controls its yaw motion, is to a large extent shown by a comparison between the *base case* and *yawing case 2*. A very significant increase of excessive yawing probability (10^7 times higher than in the base case) is observed. These results largely demonstrate the importance of FPSO yaw motion control. The large FPSO yaw motion may impact the probability of an excessive yawing event, at least as much as (if not more than) the situation when there is no joint mean heading operation. This is observed by a comparison between *yawing case 2* and *yawing case 3*.

4.7 FINDINGS AND RECOMMENDATIONS

To conclude the first objective, i.e. the likelihood of excessive surging and yawing, results show that, given a rather extreme offloading environment, the optimum technical configuration and operational strategy on both FPSO and tanker may result in negligible frequencies of excessive surging and yawing events ($1.59\text{E-}11$ and $3.86\text{E-}12$, respectively, per 3-hour duration). However, from sensitivity results, the excessive surging and yawing frequencies can vary up to $3.16\text{E-}05$ and $6.18\text{E-}05$, respectively, per 3-hour duration. Assume that each year there are 300 loading hours under weather condition similar to the one that are chosen, then the frequencies of excessive surging and yawing can both be in the order of 10^{-3} per year, high enough to be an important safety concern. Findings indicate that surging and yawing events should, and can be, effectively minimized.

In addition, simulation results confirm that the excessive surging event, though it may lead to a frequent reduction of the separation distance, does not directly cause the contact between FPSO and tanker, given that the mean separation distance is around 50 to 80 meters. However, it may potentially initiate technical failures and/or human errors as discussed earlier in this chapter and according to facts of incidents shown in Appendix B.

To conclude the second objective, i.e. how to reduce the occurrence of excessive surging and yawing events, findings and recommendations are as follows:

1. Significant contributions to excessive surging and yawing come from the FPSO's surge and yaw motions if these motion amplitudes are not properly dampened down. Efforts, e.g. in the form of operational guidelines, should be made to reduce the FPSO surge and yaw motions during the offloading operation, given that the FPSO has such thruster capacity.
2. The coordination of mean heading control between FPSO and tanker is important to minimize the probability of excessive yawing. Tanker and FPSO should align with the same mean heading. This heading can be determined through communication between tanker DP operator and FPSO control room operator regarding each vessel's positioning preferences and capabilities. In some cases it may be that the tanker heading is aligned with the optimum FPSO heading, while in other cases it can be that the FPSO heading is adjusted to align with the optimum tanker heading. This recommendation is valid as long as the FPSO has thruster capacity for heading control.
3. Tanker using a geo-stationary motion control window around a mean FPSO stern point for position reference can reduce the probability of excessive surging, compared to the case when a moving FPSO stern point is used for positioning. This is the measure that targets on tanker side solely, especially if the FPSO do not have thruster capacity to dampen down surge motions.

Last but not least, for tandem offloading operations involving those passively moored FPSOs which do not have thruster capacity to dampen down the surge motions, nor the heading control capability, findings show that the excessive surging and yawing events are likely to happen even if best practices and equipment are adopted on the DP shuttle tanker side. A contingency operational plan, e.g. special criteria for disconnection, should be considered in order to handle the excessive surging and yawing – these likely (with such FPSOs) and failure prone situations.

C H A P T E R

5. FAILURE OF RECOVERY

“...accidents occur, not because they (pilots) have been sloppy, careless, or willfully disobedient, but because we on the ground have laid booby traps for them, into which they have finally fallen.”¹

– R. HURST

A tanker drive-off forward event does not turn into a collision incident with the FPSO, if recovery initiated from the tanker is successful (See Eq.2-2 in Chapter 2). In this chapter, recovery actions initiated by the tanker DP operator in drive-off scenarios are studied.

Recovery actions are guided by three possible recovery strategies. The one that is favored by the majority of shuttle tanker DP operators and safety specialists is to stop tanker, and meanwhile combine the effort to rotate the vessel bow away from the FPSO stern. Based on calibrated tanker motion simulations, the time available for the DP operator to initiate recovery action so that tanker can be stopped within a separation distance to FPSO, e.g. 80 m, is found to be critically short. A 3-stage Information-Decision-Execution model is generalized to model the DP operator’s information-processing stages regarding action initiation when in a drive-off scenario. Based on this human information-processing model, expert judgment by simulator trainer and a questionnaire survey with shuttle tanker DP operators are conducted, to obtain a reasonable estimate of the time needed for action initiation. The estimates are found convergent to the facts in the incidents. Findings may imply that tanker DP operators in general need more time to initiate recovery action than the allowable time window. In other words, recovery failure is likely due to lack of reaction time. Two principal recommendations are proposed accordingly, i.e. to increase the available time window and/or to reduce the DP operator reaction time.

¹ Hurst R and L.R. (editors) *Pilot Error*. 2nd Ed., Aaronson, New York, U.S.A. 1982. The sentences was quoted in Kletz (2001).

5.1 PROBABILISTIC MODELING AND OPERATIONAL DATA

The recovery initiated from tanker is essentially the response actions taken by the DP operator in a drive-off scenario. The probabilistic model of tanker initiated recovery in the recovery stage can in principle be written as follows:

$$P(\text{collision}) = \sum_i \sum_j P(\text{collision} | AR_j, PFM_i) \times P(AR_j | PFM_i) \times P(PFM_i) \quad (5-1)$$

$P(PFM_i)$ is the probability of a powered forward movement (drive-off forward) scenario i , $i = 1, 2$ as shown in Eq.3-1 in Chapter 3. $P(AR_j | PFM_i)$ is the probability of DP operator's recovery action j which is time dependent, and it is conditioned on drive-off scenario i . $P(\text{collision} | AR_j \& PFM_i)$ is the probability of collision conditioned on drive-off scenario i and recovery action j .

To assess the failure of recovery, the following two questions need to be answered:

1. What are the possible recovery actions in drive-off scenarios, i.e.
 $P(AR_j | PFM_i)$?
2. What is the likelihood that these actions to prevent collision, i.e.
 $P(\text{collision} | AR_j \& PFM_i)$?

Extensive operational data are collected and pooled together to answer these two questions. These operational data, which are important to the credibility of the following analyses, include the following:

- Operational manual and guidelines (SMS, 2000). Observation of simulator training (Chen, 2000). Observation of the tandem loading operation on a North Sea shuttle tanker (Chen, 2001).
- Incident and near miss information (Appendix B). Talk through and walk through of recovery action onboard a shuttle tanker (Chen, 2001).
- Interviews with operators and experts, including: shuttle tanker captain and DP officer (Chen, 2001), DP software designer (Hals, 2001), simulator DP training instructor at Ship Manoeuvring Simulator Centre in Trondheim (Chen, 2002b), and safety specialist (Helgøy, 2002).
- Questionnaire survey with shuttle tanker captains and DP officers (Chen, 2002c & 2002d).

5.2 RECOVERY ACTION IDENTIFICATION

The recovery actions performed by the tanker DP operator can be considered as guided by the three recovery strategies shown in Figure 5-1. The recovery actions and the event

development accordingly are modeled by combining an event tree model with a time axis in Figure 5-2. The three recovery strategies are exemplified by routines (1), (2), and (3) in the event tree model. The event tree provides an overview of how an event may develop (into collision or near miss) under various recovery actions from the DP operator. The time axis starts at the initiation of drive-off. Operator action timing is represented from T1 to T5, respectively.

The No.1 strategy is to maximize the rudder and thruster effect so that maximum turning moment is generated, and tanker is steered away from FPSO stern. Note that during this strategy, no efforts are made to stop the tanker. The No.2 strategy is to try to gain local thruster control and command full astern thrust so that tanker could be stopped within the separation distance to FPSO stern. The No.3 strategy can be seen as a combination of the above two, i.e. try to gain full astern thrust and initiate maximum turning moment from rudder and thrusters.

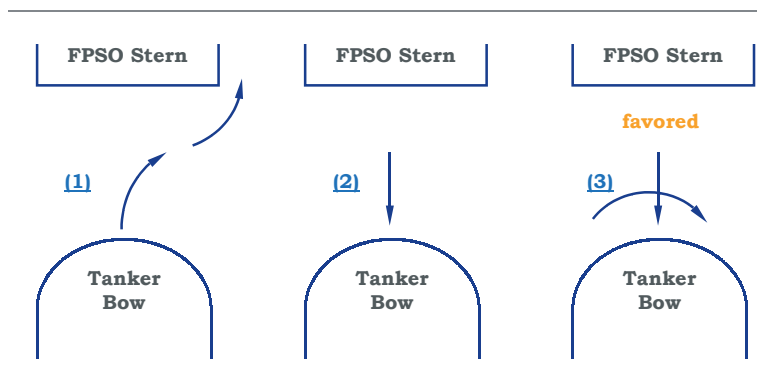

Figure 5-1 Recovery strategies

There are different views regarding which recovery strategy is the optimum one in drive-off scenarios. For example, in the previous study by HSE (1997), the No.1 strategy was favored, while the No.2 was claimed to be “most likely to fail”. However, in this study, we found that No.3 strategy is favored by the majority of shuttle tanker DP operators and safety specialists. The main reason for selecting this strategy is that it appears to be the safest (at least minimizing the impact energy), and it is “natural” to perform in a high-stress situation. The questionnaire survey and interview further reveal that to *stop* the tanker is the primary objective in the operators’ mind, and to *steer* tanker away from FPSO stern is mainly done to help achieving this goal.

The recovery actions may be carried out by using the DP joystick in Manual DP mode, or by switching off the DP and maneuvering the tanker via manual steering gear. Both had happened during actual collision incidents and near misses (Appendix B). Again, findings in the questionnaire survey show that the majority of operators prefer to use the DP joystick, or at least try this alternative first unless it is found not to work. The main reason for using the DP joystick is that it is considered time saving, and the DP console (and associated position reference system screens) offers a better overview.

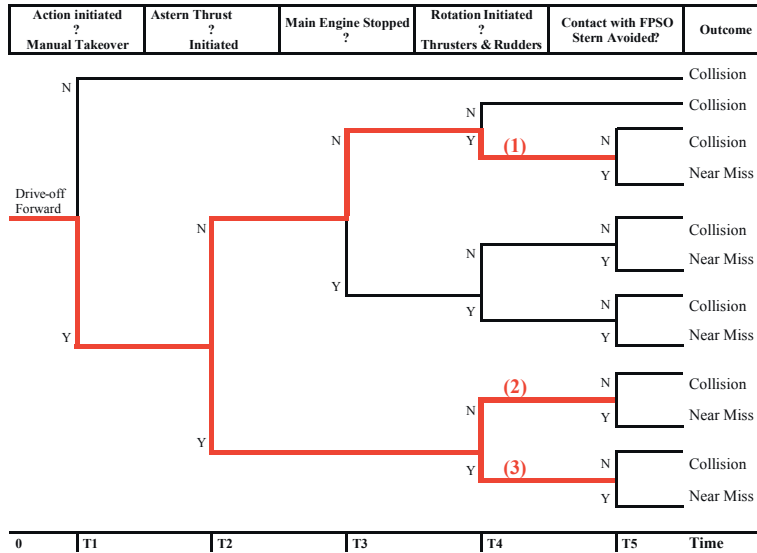

Figure 5-2 Event tree presenting scenarios initiated by drive-off forward

5.3 TIME WINDOW FOR SUCCESSFUL RECOVERY

A shuttle tanker is not easy to stop or rotate. Its propulsion and steering systems may take 20 to 40 s to build up to their maximum astern/rotation responses (Tønnessen, 2001; Gudmestad, 2001). Even when these machines reach their maximum effects, the big tanker mass will make the vessel response slow. Given a nominal distance to FPSO stern as short as 70-80 m (or shorter), and in a full ahead drive-off situation, clearly a successful recovery, i.e. to be able to stop tanker (with possible rotation), requires that the recovery action is initiated at a very early stage in the drive-off scenario.

The allowable times for DP operators to initiate action so that a successful recovery can be made in a full ahead drive-off scenario are estimated. Results (termed as the time window) are presented in Table 5-1. Note that successful recovery here means to stop tanker within a specified separation distance, and there is no rotation involved. This implies that estimations of the allowable time are on the conservative (safe) side.

Separation Distance (m)	50	80	120	150
Time window for successful recovery (sec)	37	53	72	81

Table 5-1 Time window for successful recovery conditioned on separation distance

The estimations are derived from a calibrated motion simulation for a generic North Sea shuttle tanker. The simulation work is carried out by a time-domain simulation code,

SIMO. The tanker simulation model is adapted as the one used in Chapter 4, and it is calibrated based on the full-scale measurement of a North Sea shuttle tanker drive-off behavior recorded by the BLOM PMS system¹. The calibration work is documented at the end of this chapter.

It is clear from Table 5-1 that the time window for successful recovery is critically short. Note that the whole tandem offloading operation may last over 20 hours. Meanwhile, a full ahead tanker drive-off initiated by the DP system for example, may only need 2 minutes to develop into a collision with the FPSO. The tanker DP operator has to initiate recovery action within the first 53 seconds after drive-off to make a successful intervention, given an 80 m separation distance. This is a very stressful situation.

5.4 MODELING OF ACTION INITIATION

A quantitative estimate of how much time a tanker DP operator in general needs to initiate action is needed, i.e. the **T1** corresponding to the “Manual Takeover” action in Figure 5-2. A quantitative estimation of **T1** has to be based on a sound qualitative understanding of the information-processing stages that a tanker DP operator undergoes before he or she² acts.

There have been many studies of operator action and time in emergency situations in the past two decades, for example Time Reliability Correlation (TRC) (Hannaman and Worledge, 1988) and Human Cognitive Reliability (HCR) (Dougherty and Fragola, 1988) in the late 1980s, operator cognitive model and response action analysis under accident conditions (Parry, 1995; Hollnagel, 1996; Smidts et al., 1997) in the mid-1990s, and human reliability of emergency tasks in nuclear power plants (Pyy, 2000; Jung et al., 2001) in the early 2000s.

However, the context of a shuttle tanker is different from that of a nuclear power plant (NPP), which many of the above studies are largely rooted. The nature of the task, human-machine interface, and safety culture, to list a few, are basically different. Moreover, during an emergency drive-off scenario on tanker in tandem offloading, a tanker DP operator is not, as the control room operator in NPP is when under emergency, guided to take corrective actions with various emergency operating procedures (EOPs). EOPs for DP operator in a tanker drive-off scenario in tandem offloading are in general scarce.

A simple 3-stage Information-Decision-Execution model is generalized to model the information-processing stages that a DP operator generally experiences from 0 to **T1** in a tanker drive-off scenario. Note that the objective of this human action model is to

¹ BLOM PMS system is a position monitoring system which is installed on shuttle tankers. It has a position data log, e.g. tanker position and speed.

² I use he/him/his thereafter when referring to the DP operator, although the person may be either man or woman.

provide the basis for the following quantitative estimation of the response time **T1** in the present scenario. Further work will be needed if this human action model is used for other purposes, such as human error analysis. A qualitative description of operator activities prior to recovery action initiation in a tanker drive-off scenario is provided below. This is based on the collected operational information, and it is the factual background of the generalized model.

Information – During DP watch, the operator may detect *abnormal signals (detection)*. For example, he may be alerted by a distance alarm. Or he may, when monitoring the offloading, observe an abnormal thrust output, or he may observe that the vessel starts to gain forward speed. After the DP operator detects the first abnormal signals, he may start to actively search for information (*observation*) to clarify the situation (*state evaluation*), i.e., whether there merely is a wrong signal or whether a drive-off actually takes place. He may perform crosschecks of four information sources, i.e. position, speed, thrust output, and alarm, to detect the situation. Other sources, e.g. noise from engine and vibrations, may also be paid attention to.

Decision – This stage involves interaction between *state evaluation* and *task formulation*. During state evaluation, the DP operator processes the information obtained. He may find that it merely is a wrong signal, and then select a minor, correcting task. Or he may find that this is a drive-off, and he will have to check the vessel position (distance to FPSO), speed, and the thrust output all over again. The information helps him to decide on how critical the situation is, how much time window he has, and this helps him to formulate the appropriate tasks which he believes will prevent the collision. He will also consider the environmental conditions and vessel thruster, rudder capacities, and response time, when planning the tasks.

Execution – The last stage is the task *execution*. The formulated tasks are transformed into sequenced *muscle commands*, and the DP operator subsequently confirms (by observation) that the execution is being achieved. Note that this stage may be rather brief if the command is quickly confirmed as intended. However, in some cases when there have been some technical failures, a command may result no effect at all, or in a stressed situation, the command can even be performed on a wrong object. The operator may try again and wait (search information to confirm that the command is being achieved) and try until he decides to perform another task or identifies the right object for command. In those cases, the execution stage may involve a longer time span.

The Information-Decision-Execution model is presented in Figure 5-3 with the time reference. Note that these three stages do not happen in a purely linear, sequential manner. The estimation of DP operator action initiation time T1 in a drive-off scenario is accordingly based on estimations of the following three characteristic time interval values as shown in Figure 5-3:

- *Information* time: 0-Ta
- *Decision* time: Ta-Td
- *Execution* time: Td-T1

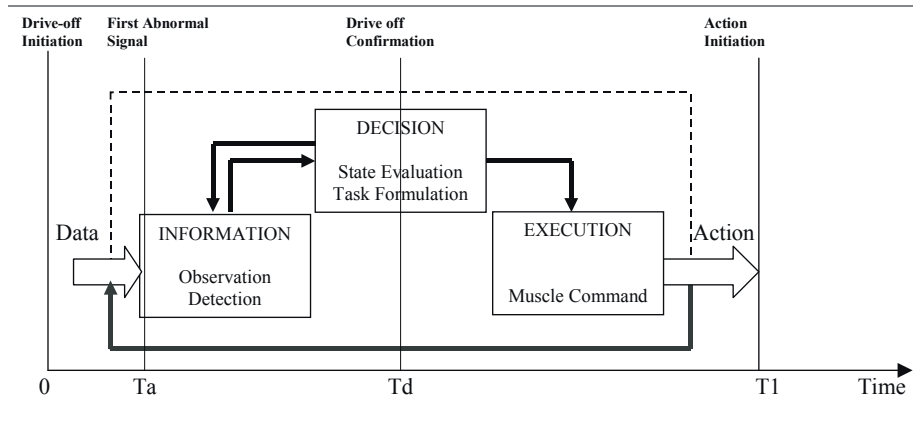

Figure 5-3 Information-Decision-Execution model for DP operator reaction in drive-off scenarios

The theoretical background for constructing this simple 3-stage operator action model is briefly described here. First, this model is largely adapted from the human information-processing model used in a study of pilot action in aviation operations by Wickens and Flach (1988). More details concerning this human information-processing model can also be found in Appendix A, or from the recent engineering psychology book by Wickens and Hollands (2000). The aviation pilots perform operations in a context which is considered to be of significant similarity to the one shuttle tanker DP operators face in drive-off scenarios. For example, both cases involve receiving external information, assessing the situation and performing action under critical time pressure. Both have a few action alternatives to choose, and actions are all performed in a confined area (airplane cockpit vs. tanker bridge) with various steering gears. However, significant simplifications have been made in our model due to its present objective.

Second, the hierarchy and interaction between *Information* and *Decision* in our model are rooted in the Step-Ladder model developed by Rasmussen (1986). The interactions between various stages in the Step-Ladder model are reflected in our model between *Information* and *Decision*. Note that there is no direct link from *Information* to *Execution* in our model. This is because this type of “skill-based” behavior is not considered possible, i.e., the tanker DP operator will not simply disconnect and initiate full astern maneuvering by reacting “automatically” to one or several signals.

5.5 TIME NEEDED FOR ACTION INITIATION

On average, experienced tanker DP operators may need 60 to 90 s to initiate recovery action. This is the conclusion derived from the following three sources: a) information from incidents and near misses; b) expert judgments by a DP training instructor based on his extensive experiences with tanker offshore loading training, in particular the drive-off scenarios training in simulator; and c) a questionnaire survey among North Sea shuttle tanker captains and DP officers.

5.5.1 Incident information

The operator action initiation time and collision (or tanker stop) time after drive-off are summarized in Table 5-2, based on the available information from six incidents and near misses. Further details can be found in Appendix B.

Collisions	Recovery action time since drive-off initiation (s)	Collision time since drive-off initiation (s)
b	Close to 120	120
c	91	143
d	167	Not available
g	58	125
Near Misses	Recovery action time since drive-off initiation (s)	Stop time since drive-off initiation (s)
f	45	140
i	Very short	75

Table 5-2 Operator recovery action initiation time (incident data)

The time span of the action initiation is observed between 58 to 167 s in collision incidents, and from 'very short' to 45 s in near misses. Further, incidents b, c, and g could be considered as collisions due to full ahead tanker drive-offs, based on the time from drive-off initiation to collision. These three incidents may imply that the time needed to initiate recovery action lies between 60 to 120 s.

5.5.2 Expert judgment

The operator action initiation time is estimated by a DP training instructor in the Ship Manoeuvring Simulator Centre (SMS) in Trondheim. This instructor has experience from hundreds of tandem offloading DP training courses performed in the past a few years. During the courses, the participants are at a random time exposed to various failures that may cause (or combine with) tanker drive-off. The instructor observes the participants' responses in the Bridge simulator via a video camera. (There are however no records of performance during training. This rules out the possibility of a statistical analysis of response time in training.)

The estimation process is built on the simple operator response action model presented in Section 5.4. Detailed estimates are presented in Table 5-3. The approach is outlined below. 100 times of training with experienced DP operators are considered. The population excludes training of officers who are first-time participants in tanker offshore loading DP training course, and who seldom have operated the DP onboard. They spend much more time to initiate action in simulated drive-off scenarios. After initiation of tanker drive-off, percentage of training is estimated for different time

intervals for the *Information*, *Decision*, and *Execution* stages (0-Ta, Ta-Td, Td-T1, respectively). The *Information* and *Decision* stages are distinguished by observing that the “trainee has detected the first abnormal signal relating to drive-off”. The time intervals were pre-made and were updated by the expert during the estimation process. In practice, it is difficult to differentiate the *Decision* and *Execution* stages from the observation of trainee performance in the simulator, therefore these two stages are grouped together.

Time (sec)	Information Stage				Decision and Execution Stages			
	0 - 10	10 - 20	20 - 30	30 - 50	0 - 20	20 - 30	30 - 60	60 - 90
No. out of 100 times Training	10	20	20	50	0	20	30	50
Probability	0.1	0.2	0.2	0.5	0.0	0.2	0.3	0.5

Table 5-3 Expert judgment of recovery action initiation time based on simulator training

Mean values are calculated based on the results in Table 5-3. The mean *Information* time is 29 s, and the mean *Decision* and *Execution* time is 56 s. The recovery action is then averagely initiated about 85 s after the initiation of drive-off. These results largely converge with the incident data.

During estimation, the expert commented that the work attitude heavily influences the detection of abnormal signals indicating tanker drive-off. The experience gained from emergency training and knowledge of the system (hardware) are two factors that have significant impact on the time involved in decision and action execution.

5.5.3 Questionnaire survey

The questionnaire survey conducted in the spring of 2002 with shuttle tanker DP operators provides quantitative estimates of the time needed for recovery action initiation directly from the front-line operators. The questionnaire is attached in Appendix E. A total of 17 shuttle tanker DP operators (captains and DP officers) participated, and 16 of them provided applicable feedbacks for time estimation. The operational experience behind these 16 feedbacks involves 1093 tandem offloadings. The questions are designed according to the 3-stage human action model presented above. Specifically, the answers to the below questions are essential for an estimation of a *reasonable* action initiation time. The term “reasonable” is important in this context. The questions are not for performance evaluation, i.e., to find out who is the best. They are formulated to clarify what the reasonable human capability is.

1. What is the first “abnormal signal” in the *Information* stage?
2. What is the decision process, and how much *Decision* time (Ta-Td) is needed in the *Decision* stage?

3. What is the preferred recovery strategy, where should the needed actions be performed, and how much *Execution* time (T_d-T_1) is needed in the *Execution* stage?

The mean time for recovery action initiation is found to be about 60 s after drive-off. The 16 individual estimates are plotted in Figure 5-4. As shown in the figure, the reasonable *Decision* time and *Execution* time are directly provided by each DP operator, and an indirect estimate of reasonable *Information* time is then added uniformly.

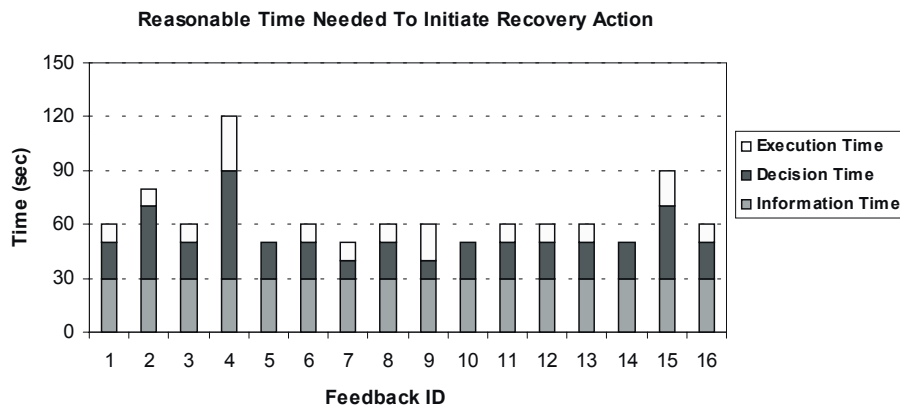

Figure 5-4 16 estimates of reasonable time needed to initiate recovery action

The reasonable *Information* time is indirectly found as 30 s after drive-off. This is based on the following reasoning: The most likely “first abnormal signal” is identified in the survey. In non-alarm category, it is the “Thruster output on DP console before any alarm”. In alarm category, it is the “DP short distance warning”.

The detection time of the alarm signal, assuming the “DP short distance warning” alarm goes off at -10 m of setpoint distance, is estimated from the calibrated simulation of the shuttle tanker drive-off behavior which is presented at the end of this chapter. This alarm goes off at 31 s after drive-off. The -10 m assumption comes from a generic tandem offloading field configuration as shown in the tandem offloading guideline by (UKOOA, 2002).

The detection time of the non-alarm signal, i.e., the thruster output on the DP console, may vary from person to person depending on e.g. job attitude and current attention level. More discussions on factors that influence the non-alarm signal detection are provided in Chapter 7. The non-alarm signal may likely be detected earlier than any warning/alarm, but it may not be as reliable as the warning/alarm to prompt the operator’s attention. The estimation made by the simulator instructor shows that 29 s is a mean time involved. A representative *Information time* is therefore derived as 30 s after drive-off.

5.6 FAILURE OF RECOVERY

The tanker-initiated recovery is considered in this chapter. The possible recovery strategies are identified and the one that is favored by most shuttle tanker captains/DP officers and onshore safety specialists is to initiate astern maneuvering of tanker, combined with the effort to rotate the vessel bow away from the FPSO stern.

Given the recovery strategy favored by operators in general, the failure of recovery is still significant due to lack of reaction time. For example, given a typical 80 m separation distance between FPSO and tanker, and a full ahead tanker drive-off, recovery action has to be initiated within 53 s after drive-off to avoid collision. The incident data demonstrated that human operators may not be able to react in such short time. The expert judgments based on simulator training indicate that the mean action initiation time for experienced tanker DP operators is about 85 s, and only 20 % to 30 % of them are able to initiate recovery action within a time window of 53 s. A further concrete estimate of action initiation time comes from the questionnaire survey with shuttle tanker captains and DP officers. Findings may imply that the mean action initiation time based on reasonable human capability is around 60 s after drive-off (or 30 s after detecting alarm or non-alarm abnormal signals). In other words, potentially the failure probability of recovery could be more than 50 %. The situation can be worse if a shorter separation distance is adopted in the operation.

Ideally, the tandem offloading operation should be configured to ensure that tanker DP operators get a reasonable time window to initiate recovery action, given a full ahead tanker drive-off scenario. After all, a DP shuttle tanker drive-off in offshore loading is not a rare event, as demonstrated by recent collision incidents and near misses in Chapter 3.

However, reality often tells a different story. The operation is configured with little consideration of time windows for recovery in the first place. Efforts are mainly directed to “modify” operators by training and “make” them able to initiate recovery action within a critically short time span, should a drive-off happen. After collision incidents, “tanker DP operator did not initiate recovery in time” became a typical verdict of human error in the investigation reports. In this connection, it is worth mentioning what Hurst pointed out regarding airplane pilot error accidents 20 years ago, “...accidents occur, not because they [DP operators in the present case] have been sloppy, careless, or willfully disobedient, but because we on the ground have laid booby traps for them, into which they have finally fallen” (Hurst, 1982).

5.7 FAILURE REDUCTION MEASURES

“More training” typically tops the list for risk reduction measures if human operators are involved. Emergency training of individual DP operators both on board and in simulators for quick and effective reactions is by all means important. Tanker captains and DP officers undergo rigorous training, as is reflected in the UKOOA guideline (UKOOA, 2002). However, it is important to take a more effective approach to the issue. As argued by Kletz (2001), to prevent human failure and recurrence of an

incident, an effective approach is actually to “change work situations, not people”. Therefore, the following two recommendations, which are aimed to improve the success of recovery, are proposed from the perspective of changing the work situation:

1. To provide a longer time window for the operator to initiate recovery action.
2. To provide various kinds of assistance to the operator to reduce the recovery action initiation time.

To ensure enough time for tanker DP operator to initiate recovery action is of vital importance. On the top level, apparently two options are available: One is to substantially increase the separation distance between FPSO and tanker; the other is to reduce the forward thrust from the main engine/propeller(s) that potentially can be involved in drive-off. The feasibility and implementation issues regarding these two measures are further discussed in Chapter 6.

Efforts may also be directed to effectively reducing the operator reaction time. According to the operator information processing model in Section 5.4, and estimates by DP operators in the questionnaire survey, effective reduction of operator reaction time can be achieved by reducing the *Information* time and the *Decision* time. A number of measures are identified, i.e. training, procedure, crew resource management, human-machine interface design, and automation support, which are designed to improve early detection as well as effectively reduce operator’s time in diagnosis and situation awareness. The feasibility and implementation issues regarding these measures are further discussed in Chapter 7.

C H A P T E R 5 - A N N E X
T A N K E R M O D E L C A L I B R A T I O N

The shuttle tanker model used in the time window simulation here is the same vessel used in the surging and yawing simulation study. Its main particulars and hydrodynamic data in SIMO are provided in Chapter 4, Section 4.3.

The calibration work is based on a full-scale measurement of a North Sea shuttle tanker drive-off event recorded by the onboard BLOM PMS system. The setpoint distance, bearing, speed, and vessel heading data for a North Sea shuttle tanker in a collision incident with an FPSO were recorded, and the episode is reconstructed into a video show (Blom, 2002).

The FPSO heading was 250° clockwise relative to the North, and this heading was kept more or less constant. The tanker heading was around 228° (with variation from 227° to 228°) throughout the drive-off. The minimum distance between tanker and FPSO, as illustrated in Figure 5-5, can be derived by setpoint distance and bearing information as in Eq.5-2.

$$D_{\min} = D_{\text{setpoint}} \frac{\cos(\theta_{FPSO} - \theta_{\text{Bearing}})}{\cos(\theta_{FPSO} - \theta_{\text{Tanker}})} = D_{\text{setpoint}} \frac{\cos(250^\circ - \theta_{\text{Bearing}})}{\cos(22^\circ)} \quad (5-2)$$

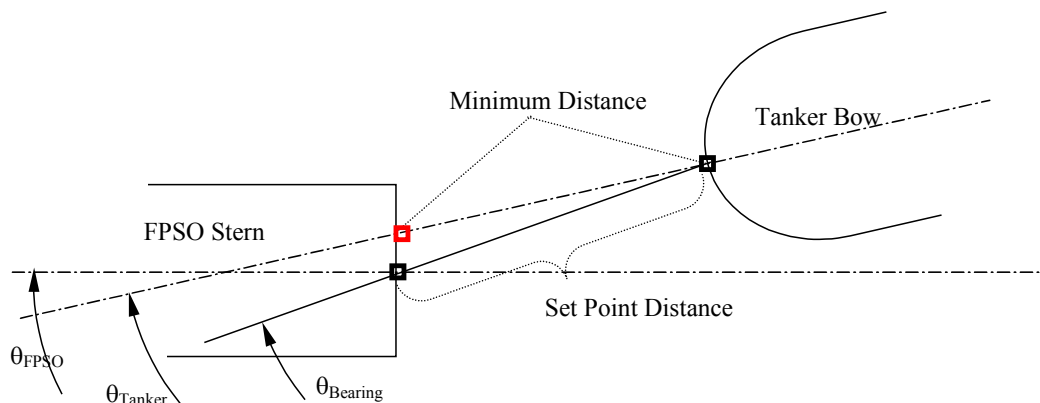

Note: Directions are clockwise, relative to the North.

Figure 5-5 Setpoint distance, bearing, vessel headings, and minimum distance

The drive-off distance is derived from the calculated minimum distance values. The starting point is taken from the first Blom data point, and it is 2 s after drive-off initiation. Note that the time of drive-off initiation is found from investigation

information. This position can therefore be viewed as the approximate initial position of the tanker. The calculated drive-off distance values together with the tanker speed data are listed in Table 5-4.

Time (s) after Drive-off initiation	Setpoint distance (m)	Bearing (°)	Drive-Off distance (m)	Tanker speed (kn)	Tanker speed (m/s)
2	75.2	214	0.0	0.1	0.05
20	71.0	216	2.1	0.3	0.17
36	64.8	211	11.3	0.7	0.36
43	60.8	213	13.2	0.8	0.41
46	59.5	211	15.7	0.9	0.46
51	55.2	212	18.7	1.0	0.51
58	50.4	208	25.2	1.2	0.62
63	47.0	206	29.1	1.3	0.67
68	45.1	203	32.4	1.4	0.72
74	39.6	199	38.7	1.5	0.77
84	32.1	195	45.7	1.5	0.77
94	27.0	186	52.8	1.5	0.77
100	25.1	178	57.2	1.5	0.77
110	23.5	165	63.4	1.4	0.72
115	25.1	155	68.0	1.3	0.67
120	25.2	149	70.8	1.2	0.62
125	26.7	144	73.5	1.2	0.62

Table 5-4 Tanker drive-off distance and speed

The warning/alarm events can be observed directly from the reconstructed Blom video. The collision took place at around 125 s after drive-off, since after this time the drive-off distance stopped to increase with the time. The recovery action was initiated at 58 s after drive-off initiation.

Idealized simulations are made in the still water cases. The same operator action is imposed at the exact time in simulation as happened in the measurement. The tanker propeller force is assumed to vary linearly in simulation. The rising and falling time for ahead/astern propeller forces are both 30 seconds. The steady forward thrust and astern thrust involved in drive-off are estimated as 1650 kN and 1500 kN, respectively. The simulated distance-time and speed-time plots are presented in Figure 5-6 and Figure 5-7. Reasonable agreement between the simulation results and the measurement data is observed in these plots. Therefore, the calibrated tanker model is considered to be able to simulate a representative tanker drive-off behavior.

By varying one parameter, i.e., the operator action time, various distances needed to stop the tanker can be found. The times corresponding to a 50 m, 80 m, 120 m, and 150 m stop-distance are in this way estimated, as listed in Table 5-1.

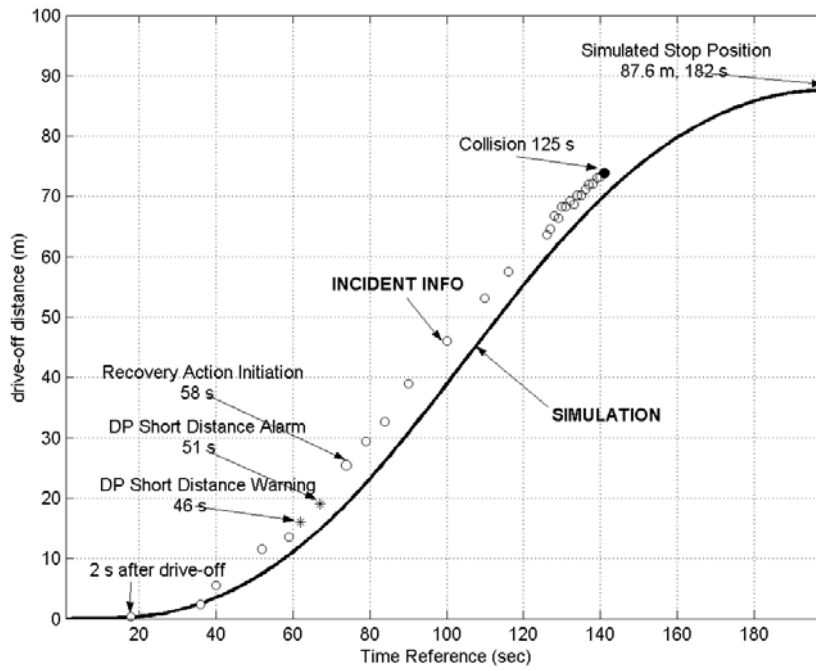

Figure 5-6 Distance-time plot of simulated and measured tanker drive-off behavior

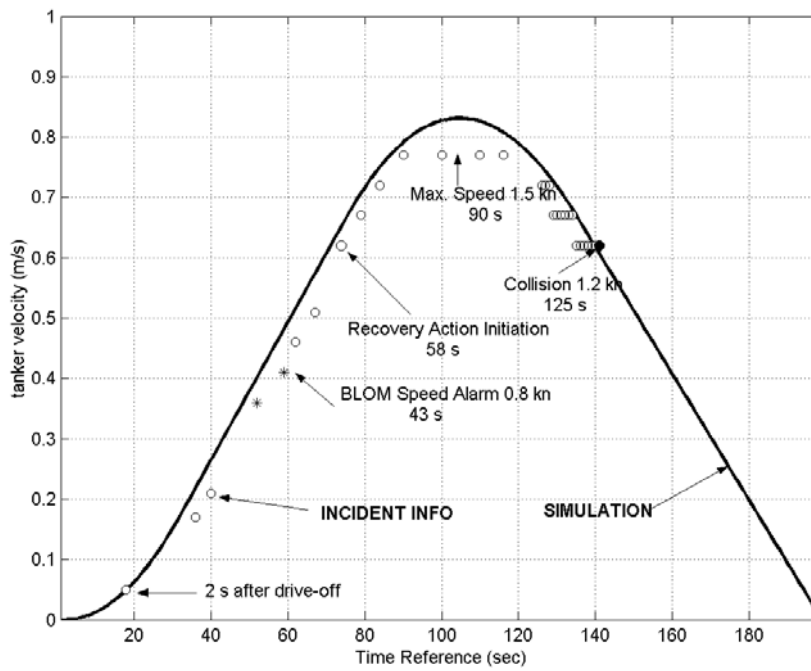

Figure 5-7 Speed-time plot of simulated and measured tanker drive-off behavior

6. INCREASE TIME WINDOW

Try to change situations, not people. – An engineer's view of human error.¹

– TREVOR KLETZ

To increase time window is identified as one of the two principal recommendations to reduce the failure probability of tanker initiated recovery. There are two apparent, feasible measures: one is to substantially increase the separation distance between FPSO and tanker; the other is to reduce the forward thrust from main engine/propeller(s) that potentially can be involved in drive-off.

The feasibility of the separation distance extension is discussed from several perspectives, and the gain in recovery improvement is quantified. The feasibility and implementation of main propeller thrust reduction is only briefly outlined due to the immaturity of this measure at present. The key question concerning implementation of separation distance extension is to know how much separation distance should be configured in the operation. This has to be based on considerations of both the human operator's need for reaction time, and tanker drive-off behavior. These two considerations are integrated through a parametric tanker drive-off motion simulation in which human action at various times is imposed. The calibrated tanker model in Chapter 5 is continually used here. Necessary distance values to stop the tanker (ideally the separation distance to the FPSO) are obtained from parametric simulations. The findings may provide decision-making support to select an optimum field configuration for FPSO-tanker tandem offloading, which may inherently minimize the collision risk.

6.1 FEASIBILITY

6.1.1 Separation distance extension

A substantial increase of separation distance between FPSO and tanker, for example from 80 m to 150 m, is considered practically feasible. The positive evidences are found

¹ Kletz T. *An Engineer's View of Human Error*. 3rd Ed., Institution of Chemical Engineers, 2001.

from a number of perspectives, i.e. limited hardware modification, virtually no additional operational complexity, and positive opinions of operators.

Certain minor modifications of the offloading hardware are required, i.e., the loading hose and mooring hawser have to be prolonged. In practical terms, this is considered as a limited investment. However, on some existing FPSO installations, a longer hose may require some modifications of the hose handling equipment, e.g. a bigger diameter hose reel. Position reference systems, e.g. Artemis and DARPS (Differential Absolute & Relative Positioning System) which sending FPSO position to tanker, are in general in normal function within a 300 m (or up to 1000 m) distance. Therefore these safety-critical systems do not need to be modified.

The increase of separation distance may only add limited extra complexity of marine operation. The tanker can follow the same procedures to approach the FPSO, and connect hawser and hose at same distance close to FPSO. Then the only difference is that the tanker has to move astern to a longer separation distance during loading. The same disconnection procedures can be adopted. Several tanker DP operators expressed concerns about the larger circle that the tanker has to follow if the FPSO changes its heading, given a longer separation distance. However, this joint heading change operation can be carried out “automatically” by the tandem loading function of newly designed DP software. A larger circle may imply more time to complete the operation (same for longer time in connection and disconnection phases), but will not necessarily cause extra difficulties.

There are no objections to the increase of separation distance from tanker captains and DP officers that participated in the questionnaire survey. Instead, there is a clear message that these front-line operators want to have a longer separation distance, mostly in the range of 100-150 m. The preferred separation distance values are presented Table 6-1.

Feedback	Preferred separation distance (m)	Minimum value (m)
1	100-150	100
4	150-170	150
6	Longer than 100	100
7	150-200	150
9	Longer than 100	100
13	100-110	100
14	80-100	80
15	300 m or ship length without mooring line	300
17	Longer than 100	100
Averaged Minimum Separation Distance (exclude Feedback No.15): 110 m		

Table 6-1 Operators' view of separation distance in questionnaire survey

It is true that with a long separation distance, the tanker will be able to pick up a high speed in drive-off and subsequently result in high impact energy in collision, given that

there is no recovery (or failure of recovery). However, an apparent failure-safe recommendation, i.e. *separation distance has to be kept short, so that if there is no human intervention after tanker drive-off, tanker may only pick up a limited speed, and subsequently the impact energy will be small should a collision happen*, may not be valid due to the facts below.

In a full-ahead drive-off scenario commanded by DP system for example, tanker may gain significant speed within a relatively short distance. Based on the full-scale tanker movement measurement in a drive-off event (see Annex of Chapter 5), it is found that tanker already had 1.0 knots speed after only 19 m drive-off distance. Even if a separation distance is kept as short as 50 m, the potential impact energy involved in a collision can be very significant, e.g. in the order of over 50 MJ. This clearly demonstrates that a short separation distance cannot guarantee low impact energy. However, a 50 m separation distance will make it very difficult for tanker DP operator to initiate recovery action within the allowable time window, i.e. failure of recovery is likely.

By increasing separation distance, e.g. from 50 m to 150 m, the available time window for recovery in a tanker full-ahead drive-off scenario may increase from 37 s to 81 s. Given the reasonable DP operator reaction time found in Chapter 5, this measure may significantly reduce the failure probability of DPO initiated recovery. Further discussion of gain on recovery failure reduction is provided in Section 6.2.

6.1.2 Main propeller thrust reduction

Tanker drive-off may be categorized into two types of failure modes, i.e. local thruster control failure induced drive-off (e.g. propeller pitch failure to full ahead), and DP commanded drive-off (e.g. DP software error, erroneous position reference signal, or operator error, etc.). With the requirement of using DP2 shuttle tanker in tandem offloading in Norwegian Continental shelf (NPD, 2002), the likelihood of local thruster control failure induced drive-off is significantly minimized, while the DP commanded drive-off becomes the critical failure mode.

This measure is targeted on the reduction of the forward thrust that can potentially be used by the DP system, so that if a DP commanded drive-off happens, tanker may pick up speed slowly, and implicitly there will be more reaction time for the operator to take recovery actions. Shuttle tanker forward thrust from its main propeller(s) is primarily dimensioned according to the speed requirement in sailing, and it may have significant over-capacity for the dynamic positioning operation in offshore loading. This provides the potential for reduction of the forward thrust used by DP in tandem offloading operation.

As commented by a DP system designer, this measure is in principle feasible (Hals, 2002). However, reducing the forward thrust that can be commanded by DP may reduce the overall positioning capability of the tanker, i.e. a shuttle tanker with reduced forward thrust will have a lower operational margin if the thrust reduction function is always “on”. Therefore, the forward thrust reduction may not be activated in all weather

conditions, especially in marginal operational environments. The gain on recovery failure reduction from this measure subsequently needs further investigation.

How much thrust should be reduced while shuttle tanker maintains similar level of positioning capability? This is not straightforward to answer. The needed thrust depends on weather condition which may change in the operation, as well as the changing environmental loads on tanker due to the change of its loading condition during the operation. Further, the thrust needed to maintain position is also field-specific and typically shuttle tanker may go to various FPSO/FSU fields for offloading. These factors make it complex to calibrate a suitable reduction factor of forward thrust.

In summary, further investigation is needed to clarify the actual gain and possible implementation of the measure. Subsequently, the following sections in this chapter concentrate on the separation distance extension.

6.2 GAIN FROM SEPARATION DISTANCE EXTENSION

The gain from separation distance extension on recovery failure reduction in tanker drive-off scenario is assessed here.

As shown by the calibrated simulation in Chapter 5, increasing the separation distance offers a longer time window for successful recovery for a shuttle tanker in drive-off scenarios. Based on 16 estimates of reasonable reaction time in drive-off scenarios by shuttle tanker captains and DP officers (see Section 5.5.3), a Normal distribution is fitted to characterize the reasonable operator reaction time. Combining the two above types of information as shown in Figure 6-1, gains in terms of recovery failure probability reduction by increasing the separation distance are assessed, and plotted at the bottom in Figure 6-1. Increasing the separation distance shows a significant improvement of recovery. For example, the recovery failure probability is reduced by 54 % if the distance is increased from 80 m to 120 m, and 75% if the distance is increased from 80 m to 150 m.

Note that in general, modeling a human operator simply by mathematical distribution is rather crude. The normal distribution here is only to represent the characteristics relating to human reaction time given a specific context, i.e. drive-off scenarios, and a specific operator group, i.e. the experienced operators. This distribution should not be generalized to a generic situation. There are other possible distributions that have been used in human action time studies in nuclear industry, e.g. Weibull distribution in HCR (Dougherty and Fragola, 1988), and Lognormal distribution in TRC (Hannaman and Worledge, 1988). However, there is no strong evidence pointing to any specific distribution in this study. Therefore, the chosen Normal distribution in this study is an initial step, and it may implicitly take into account many factors that influence operator reaction time.

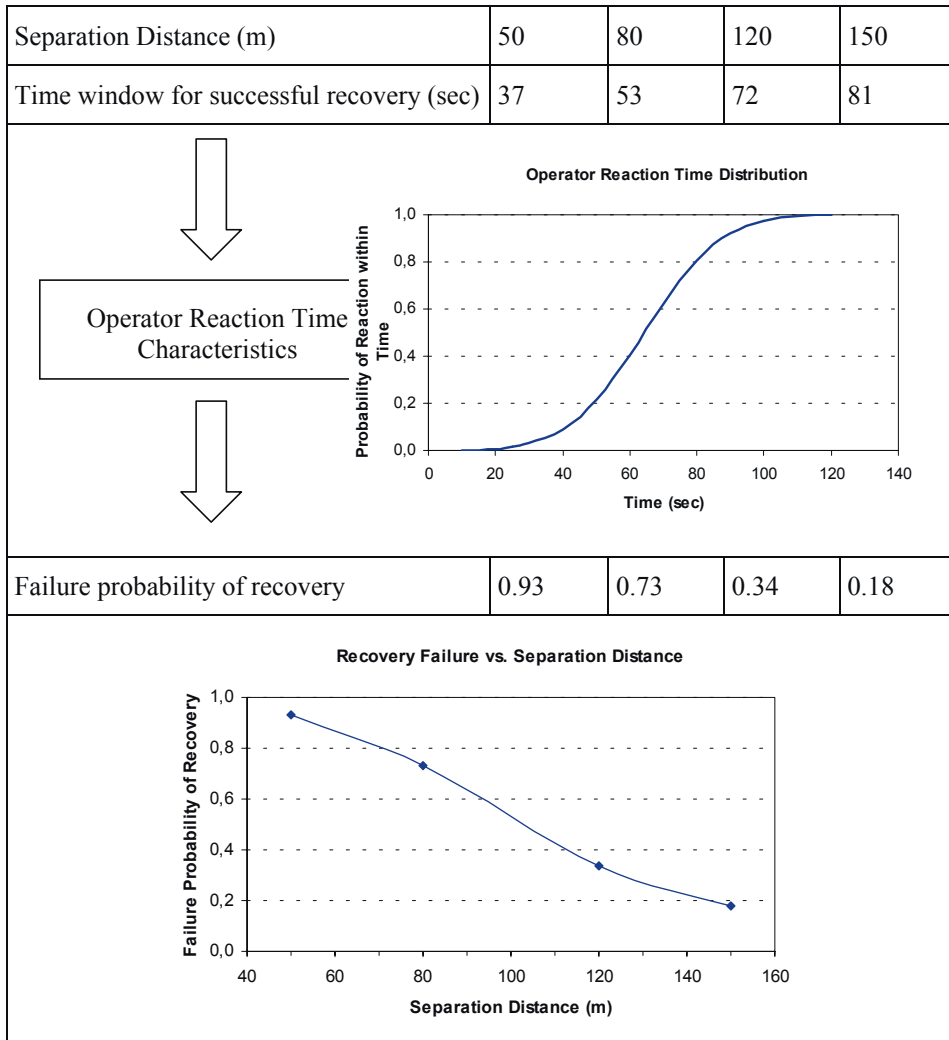

Figure 6-1 Assessing failure probability of recovery given various separation distances

In Chapter 3 the tanker drive-off frequency is found in the range of $5.4E-03$ to $2.0E-02$ per tandem loading. Assume that there are 50 tandem offloadings from a FPSO installation annually, and given the lower limit value, the annual tanker drive-off frequency in tandem offloading is roughly 0.27. Taking into account the failure probability of recovery obtained above, the 80 m separation distance may have an annual collision frequency $1.98E-01$, while the 120 m and 150 m distances will have annual collision frequencies of $9.13E-02$ and $4.89E-02$, respectively. These values are still much higher than a classic $1.0E-04$ risk acceptance criterion. Partly, we have to note that the failure probabilities of recovery come from the fitted distribution based on operators' judgment. These values are valid for pointing out the relative differences, but

may not be valid in an absolute sense for the acceptability issue. Partly, the still high collision frequencies imply that other risk reduction measures, i.e., reducing the drive-off frequency, and/or changing operator reaction time characteristics, are also important in order to further reduce the collision frequency.

6.3 DESIGN A REASONABLE SEPARATION DISTANCE

The key question concerning implementation of the separation distance extension is to know how much separation distance should be configured in a tandem offloading operation. This has to be based on considerations of both the human operators' need for reaction time, and tanker drive-off behavior. These two considerations are integrated in a parametric tanker drive-off motion simulation in which human action at various times are imposed. The simulation work is carried out in a time-domain simulation code SIMO. The calibrated tanker model in Chapter 5 is continually used here. The operator reaction time is modeled based on the 3-stage human information processing model of recovery action initiation (see Section 5.4), and findings from operator questionnaire survey (see Section 5.5). The recovery action introduced in the simulation is to initiate astern pitch from main propulsion so that the tanker can be stopped in a similar drive-off scenario as happened in one occurred incident.

Parametric cases are formulated in Table 6-2. In a drive-off scenario, the operator will firstly detect an abnormal signal. This abnormal signal can either be an alarm signal or a non-alarm signal. Two types of parametric cases are then formulated. One assumes that the operator manages a detection via the alarm signal "DP Short Distance Warning" (31 seconds after drive-off). The other assumes that the operator manages an early detection (16 s after drive-off) which may be based on one or several non-alarm signals. After the first abnormal signal has been detected, the operator needs a certain time to achieve situation awareness, formulate, and execute recovery action. Based on findings in the questionnaire survey, three further parametric cases are formulated by assuming that the operator needs 20 s, 40 s, or 60 s after detecting the first abnormal signal.

	Likely detection - 31 s after drive-off	Action Time (s)
Case I-1	20 seconds to initiate action	51
Case I-2	40 seconds to initiate action	71
Case I-3	60 seconds to initiate action	91
	Early detection - 16 s after drive-off	
Case II-1	20 seconds to initiate action	36
Case II-2	40 seconds to initiate action	56
Case II-3	60 seconds to initiate action	76

Table 6-2 Parametric simulation cases

The simulated tanker drive-off behavior and distance to stop for the six parametric cases are plotted in Figure 6-2 and Figure 6-3.

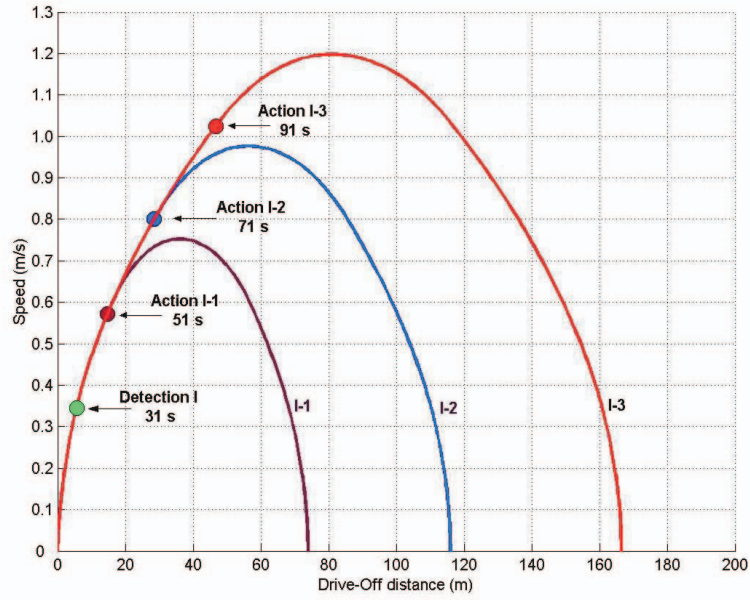

Figure 6-2 Drive-off behavior and ideal separation distance (likely detection)

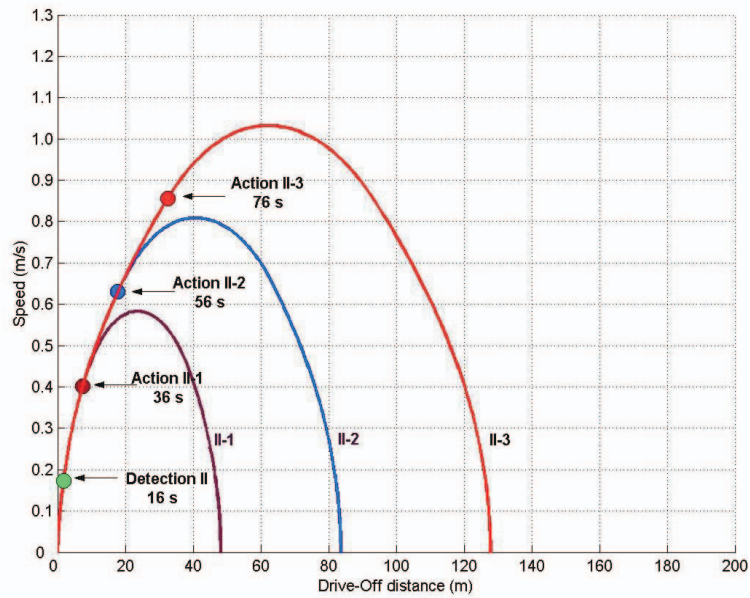

Figure 6-3 Drive-off behavior and ideal separation distance (early detection)

Given the detection at 31 s after drive-off, if the tandem offloading operation is designed to give the operator an additional 60 s to initiate recovery action, the separation distance should accordingly be set at 170 m. Note that a few meters are needed to take the FPSO surge motion into account. Based on the operator reaction time characteristics presented in Figure 6-1, it is estimated that over 90 % of the operators will be able to initiate recovery action.

Various efforts may have been made (or are to be made according to the recommendations in Chapter 7) to facilitate the operator to carry out a quick diagnosis and task execution. If there are evidence that most operators now are able to initiate recovery action within an additional 40 s after detection, given the likely detection again at 31 s after drive-off, the separation distance can accordingly be set to 120 m.

Effective early warning systems and other measures may have been provided (or are to be provided according to the recommendations in Chapter 7) so that most operators are able to make early detection at 16 s after drive-off. If again measures are provided to facilitate the operator to carry out a quick diagnosis and task execution within an additional 30 s, then an 80 m separation distance will be enough.

To conclude this chapter, the separation distance between FPSO and tanker should be configured with dual considerations of tanker drive-off behavior and time needed by tanker DP operator to initiate recovery action, should a tanker drive-off occur. Doing so will lead to an optimum field configuration for FPSO-tanker tandem offloading, which inherently minimizes the collision risk.

C H A P T E R

7. REDUCE REACTION TIME

Nothing is impossible for those who do not have to do it themselves.

– ANON

To reduce reaction time is identified as one of the two principal recommendations to reduce the failure probability of recovery initiated by the tanker DP operator. According to the operator information processing model presented in Chapter 5, reduction of reaction time may be achieved by reducing *Information* time, *Decision* time, and/or *Execution* time. However, in practice after confirming the drive-off situation, the potential time gain by reducing the *Execution* time is very limited. Evidence can be found in Section 5.5.3 regarding *Execution* time estimates by operators. Discussions of reaction time reduction are therefore focused on the two remaining areas, which form the two themes in this chapter, i.e. early detection and quick situation awareness.

To reduce the *Information* time, detection of “abnormal signal” should be made as early as possible after drive-off. Measures to improve early detection of abnormal signals are proposed which are guided by the human signal detection theory, and supported by the operational facts of alarm and non-alarm signals in the operation. The *Decision* time refers to the time that operators need to diagnose and understand the situation (situation awareness) after getting the first abnormal signal. Measures to effectively reduce operator’s time involved in diagnosis and situation awareness are theoretically built on the generic human decision-making theory, and specifically designed for drive-off intervention based on operational facts. The findings in this chapter illuminate a broad area in human factor perspective, i.e., training, procedure, crew resource management, human-machine interface, and automation support, where measures to reduce operator reaction time should be targeted on. These measures may directly reduce the FPSO-tanker collision risk in tandem offloading.

EARLY DETECTION

To reduce the *Information* time, as defined in Figure 5-3, detection of “abnormal signal” should be made as early as possible after drive-off. The early detection has a special importance in a time-critical drive-off scenario, since late detection may result in an

inevitable collision, even though quick situation awareness and swift task selection/execution can be made. In the following sections, those possible signals that indicate “something is going wrong” are identified. Based on those alarm and non-alarm signals, improvements on early detection of abnormal signal are identified and discussed.

7.1 ABNORMAL SIGNALS

The “abnormal signal” can be an alarm signal, related to vessel speed, position, and thruster output. For example, in tanker DP Weather Vane mode during loading phase, there are in total six warning/alarm signals, should tanker drive-off occur (SMS, 2000; Helgøy, 2002).

- Vessel speed alarms: 1. DP (operator-set, e.g. 0.3 kn); 2. DP (max., e.g. 0.5 kn); 3. BLOM (independent speed alarm)
- Distance alarms: 4. DP-distance short warning; 5. DP-distance critically short alarm
- Engine output alarm: 6. DP-thruster (bow/stern/main) output reaches 80 %

In addition, the “abnormal signal” may be a non-alarm signal, e.g. sound from the engine, vibration on the bridge, abnormal thruster output showing on the DP console, and so on. A non-alarm signal may typically appear earlier than a warning/alarm, and subsequently may be detected earlier.

The 17 feedbacks from the operator questionnaire survey regarding what is *the first* “abnormal signal” are presented in Figure 7-1 below. Note that it is not always possible to clearly pinpoint “the first”. Therefore most operators indicated a few possible “first signals”.

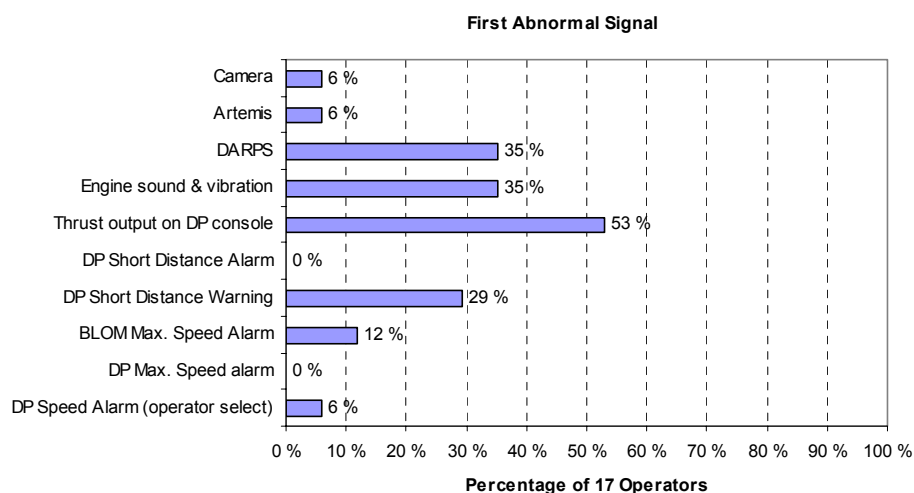

Figure 7-1 First “abnormal signal” reflected by operator questionnaire survey

The survey results show that “Thruster output on DP console before any alarm” is probably the first signal that prompts the operator to notice that “something is going wrong”. 9 out of 17 operators indicated this signal as “one of the first” or “the first”. Two other likely first-signal are “DARPS screen which shows the speed and the position before any alarm” and “Engine sound and vibration”. All three signals are non-alarm ones and are supposed to be detected before any warning/alarm.

In the warning/alarm category, “DP Short Distance Warning” is identified as the most probable signal to first tell the operator that something is going wrong. 5 out of 17 operators indicated this signal as “one of the first” or “the first”.

To detect a non-alarm signal involves a vigilant signal detection process. It requires that the operator is constantly alert since signals may be unpredictable and infrequent in the operation. An alarm signal is readily detectable. However, which parameters (e.g. speed or distance) that are chosen and which limits that are set for alarms may influence the time of detection. Initiatives regarding how to achieve an earlier detection are therefore separately addressed for alarm and non-alarm signals in the following sections.

7.2 IMPROVING EARLY DETECTION – ALARM SIGNAL

Alarm signals are readily detectable. An alarm sound and a corresponding screen text which indicates that something is going wrong will most likely prompt the operator’s immediate attention, hopefully in early stage of tanker drive-off. Note however that the so-called “alarm inflation”, i.e. a significant number of alarms go off in a very short time period potentially freezing the operator’s attention, is not applicable to the present context. When being asked about the present alarm settings, the majority of the operators (78 %) in the questionnaire survey indicated that the present alarm settings practically are effective to help an early detection of a drive-off situation. Given this positive feedback, is there any room for further improvement of alarm design and setting? The answer is probably yes.

If early detection can be effectively achieved, speed, rather than distance, must be a parameter to be paid attention to. The speed alarms should also be set so that they will go off earlier than distance alarms if drive-off happens. This is because of the following facts. As shown by the incident data in Chapter 6, a DP2 shuttle tanker may pick up speed quickly within a relatively short distance. In other words, when the distance alarm (which operators are likely pay attention to) goes off, the tanker may already have picked up a high speed. Consequently, successful recovery will inevitably be difficult, since to stop a tanker with a relatively high speed (e.g. 1.0 knots) within a relatively short distance (e.g. 60 m) is very difficult.

However, from the survey results, the speed alarms in DP (both operator-selected and system-selected maximum values) and BLOM PMS are *not* considered by most operators as the first abnormal signal, although they are indeed effective early-warning signals. In the incident information in Chapter 6, speed alarm from BLOM PMS actually went off before the distance warning/alarm. Therefore, it appears strange that speed alarms are not widely recognized as the first abnormal signal or at least among

those “first signs”. The optimistic explanation is that the abnormal speed has already been shown from the DARPS unit before any alarm, and operator has got this signal as the first abnormal signal (so they did not select speed alarm as the first abnormal signal). The pessimistic view, however, may imply that most operators do not actively utilize speed alarms in their efforts to make an early detection.

A consensus among operators regarding the use of speed alarms for early detection of drive-off has to be setup. This is the first recommendation. The importance of speed alarms may possibly be reinforced during simulator training and illustrated in an emergency operation guideline. If there is no such guideline, it is worthwhile to compile one to handle drive-off in tandem offloading. A number of the recommendations in this study and good practices from operators could be included and constantly updated in such a guideline.

Secondly, a calibration of the limits of speed alarms for a specific field operation is important. Speed alarms should not be set with too high speed limits, otherwise they may go off after the distance alarm (e.g. DP short distance warning), and no earliness of detection is achieved. At the same time, speed alarms should not be set with too low speed limits, otherwise they may go off too frequently due to tanker surge motion in normal operation. If so, the alarms will be neglected. The implementation of such calibration work has to be field specific and vessel specific. The present alarm system also enables the operator to do this calibration (select own abnormal speed limit) based on field situation, personal experience, and preference.

7.3 IMPROVING EARLY DETECTION – NON-ALARM SIGNAL

The real effective early detection has to be based on the early detection of an abnormal non-alarm signal, rather than an alarm signal. This is because of the nature of the human-machine system that we are considering now. As argued by Kletz et al. (1995) for the human-computer system, “... operators should be looking for changes or trends at the displays under their control, rather than managing by exception, i.e. waiting until an alarm shows that something is wrong. We would need much more reliable alarms than we have if operators always waited for them to operate”.

The fact that the majority of operators consider non-alarm signals as the first abnormal signal is a very positive and promising finding. This reflects that the operational principle is reasonably maintained. The “thruster output on DP console”, “speed and position shown in DARPS screen”, and “engine sound and vibration” are the non-alarm signals that most likely are being detected first. To pay attention to these signals certainly should be stated in the above proposed emergency operation guideline.

However, to detect non-alarm abnormal signals which are infrequent in a long duration operation is not as easy as to acknowledge an alarm. Researchers in the human factor area (signal detection) have concluded that this type of task (vigilance task) imposes a sustained load on the working memory of the human brain and demands a continuous supply of processing resources (Deaton and Parasuraman, 1988). This mental demand may be as fatiguing as the sustained demand to keep one’s eyes open and fixated. The

fatigue may eventually lead to the loss of vigilance, while the resource-demanding nature makes this type of task susceptible to interference from other concurrent activities (Wickens and Hollands, 2000).

Measures to improve the detection of a non-alarm signal are therefore identified as:

- [1] to prevent DP operator fatigue.
- [2] to prevent interference from other concurrent activities around DP operator.
- [3] to provide observation training.

DP operator fatigue probably originated from a non-efficient bridge resource management. In earlier practices in tandem offloading, it was typically only the captain that stayed in charge of the DP watch for the whole offloading operation. It is hard to believe that a captain can sustain a 20+ hours DP watch while keeping the same high vigilance level. Shuttle tanker operators have realized this problem in recent years and now better bridge resource management practices have been developed. An ideal example might be: two DP operators work together for 8 hours maximum, one takes charge of loading and one performs DP watch, and these two people shift their tasks once every 2 hours. This example implicitly requires that 2nd officers onboard who usually take charge of loading should also have DP certificates and be allowed to perform DP watch.

DP operator fatigue may also be caused by the present human-machine interface design. As illustrated by the figure to the left in Figure 7-2, the DP operator is sitting in an awkward position to observe the two above-mentioned non-alarm signals from the DARPS unit screen and the DP console, respectively. S/He probably has to shift attention between these two vertically located screens frequently, in order to judge if the present thruster output looks reasonable to the vessel position (relative to FPSO) and if vessel speed appears reasonable (close to zero). The BLOM PMS screen is located further away, and to observe detailed (but valuable) information shown on that screen requires more effort. A possible way to improve the working environment here is to re-design all PRS screens (reduce size) and fit them as a screen wall on top of the DP screen, as shown by the gray area in the figure to the right in Figure 7-2. It will be an integrated DP console and PRS information center where the operator has access to most of the information he needs without having to make repeated, large physical movements. The height of these re-located PRS screens should also not interfere the operator's view from the bridge window.

Potential activities on bridge that may interfere DP operator's attention during DP watch should be clarified and avoided by operational procedure. From incidents and near misses it is also clear that late detection of drive-off happened if DP operator's primary attention was not on the DP watch (interrupted by other activities), or not on those non-alarm signals that he needs to pay attention to (lack of experience). Special training for observation of non-alarm signal may be emphasized in simulator training of drive-off intervention.

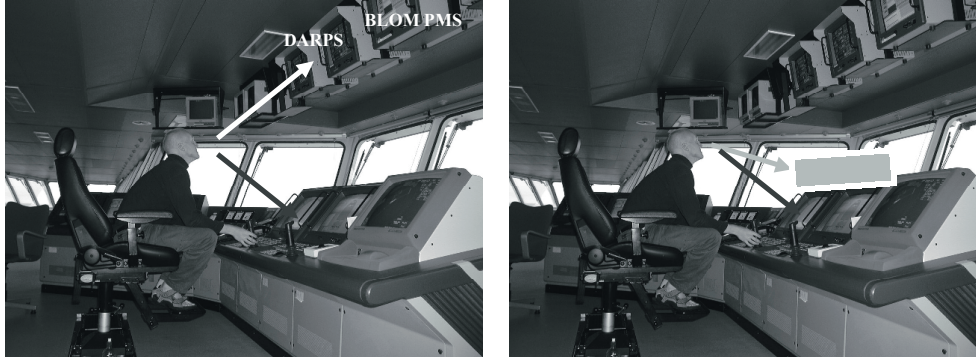

Figure 7-2 Human-machine interface problem and possible improvement

QUICK SITUATION AWARENESS

The *Decision* time, as defined in Figure 5-3 in Chapter 5, refers to the time that the operator needs to diagnose and understand the situation (situation awareness) after getting the first abnormal signal. The diagnosis and situation awareness form the foundation for effective choice or formulation of tasks to be performed. In a time-critical drive-off scenario, the present goal is to identify measures that may effectively reduce the operator's time involved in diagnosis and situation awareness. This goal is achieved through a process built on both a generic human factor theory and specific facts of the drive-off scenario in tandem offloading. The theory comes from the human information-processing model of diagnosis and situation awareness in decision-making, presented by Wickens and Hollands (2000). The facts are from findings in the operator questionnaire survey.

Note that it is mainly the time issues that are addressed. No human error issues such as diagnosis errors, wrong situation awareness, etc., are explicitly included in the discussion. However, implicitly measures to help diagnosis and subsequently to reduce time needed to understand the situation may also contribute to human error reduction.

7.4 MODELING OF DIAGNOSIS AND SITUATION AWARENESS

A human information processing model for DP operators' diagnosis and status evaluation process is presented in Figure 7-3. This model is adapted from the human information processing model for decision making developed by Wickens and Hollands (2000).

A generic interpretation of DP operators' diagnosis and status evaluation process in drive-off scenario, based on the model in Figure 7-3, is described as follows. After detection of the first abnormal sign, the DP operator will start to search for more information (*observation*). Here *selective attention* is involved for choosing which information to observe and which to filter out. Such selection is based on knowledge

and experience in *long-term memory*, and it requires attentional efforts and resources. The observed information is processed in *working memory* for updating and revising beliefs or hypotheses, i.e. diagnosis. These beliefs and hypotheses originate from knowledge and experience in *long-term memory*. There is generally an iterative process involved in diagnosis, because initial hypotheses will trigger the search for further information to either confirm or refute them. This forms a feedback loop, as reflected by the information flow labeled “confirmation” in the figure.

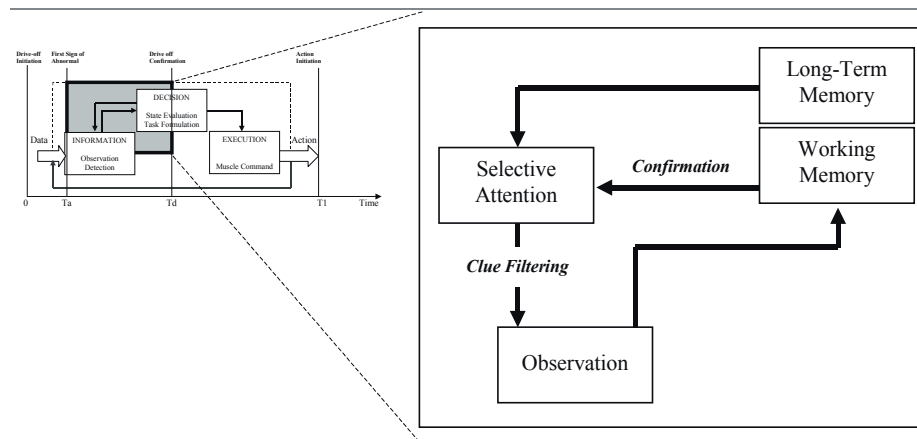

Figure 7-3 A human information processing model for diagnosis and situation awareness

Theoretically, in order to improve diagnosis and status awareness in terms of less time and better quality, we may focus on the four main information processing components in the above model as follows.

- Long-term memory – to provide background knowledge to establish possible hypotheses or beliefs.
- Working memory – to update and revise hypotheses or beliefs based on available information.
- Selective attention – to select which information to observe and which to filter out.
- Observation – to provide working memory with necessary information as directed by the selective attention.

Facts concerning the above four components for the tanker DP operator to diagnose and understand the situation after getting the first abnormal signal in drive-off are collected, and documented in the following section. Based on these facts, potential improvements are identified and discussed.

7.5 FACTS FROM QUESTIONNAIRE SURVEY

Findings from the questionnaire survey concerning the four main information processing components involved in diagnosis and situation awareness are presented below.

The *selective attention*, which is determined by the *long-term memory*, is illustrated by the following facts. 17 operators' opinions of the essential data in the diagnosis process, after getting the first abnormal signal, are presented in Figure 7-4. The majority of operators think that the following three types of data are essential in order to determine whether it is a drive-off situation.

- Tanker speed information
- Tanker position and heading relative to FPSO
- Main propeller(s) pitch information¹

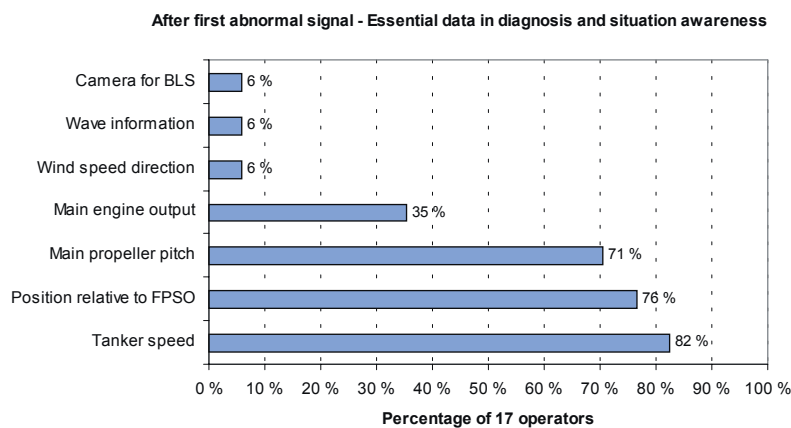

Figure 7-4 Essential data in diagnosis and situation awareness

The *observation* process, which is guided by the *selective attention*, and the information input to the *working memory*, are reflected in the following facts. To gather the wanted data, the operator may check a number of equipment screens, e.g. DP console, BLOM PMS screen, DARPS screen, wind sensor, and so on (see details in questionnaire in Appendix D). The number of screen checks each operator performs in the state evaluation process is presented in Figure 7-5.

¹ There are two types of shuttle tanker main propeller: controllable pitch propeller (CPP) and fixed pitch propeller (FPP). The majority of vessels performing tandem offloading in the North Sea use the CPP concept. The facts collected via the questionnaire survey accordingly refer to the CPP concept only.

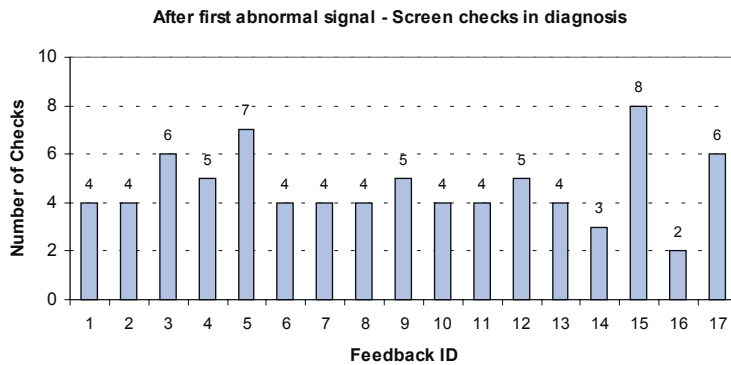

Figure 7-5 Screen checks in diagnosis and situation awareness

Results show that most operators perform four data checks, and the four most checked equipment screens as reflected in Figure 7-6 are:

- DP console
- Main Propeller Pitch indicator
- DARPS screen
- Artemis screen

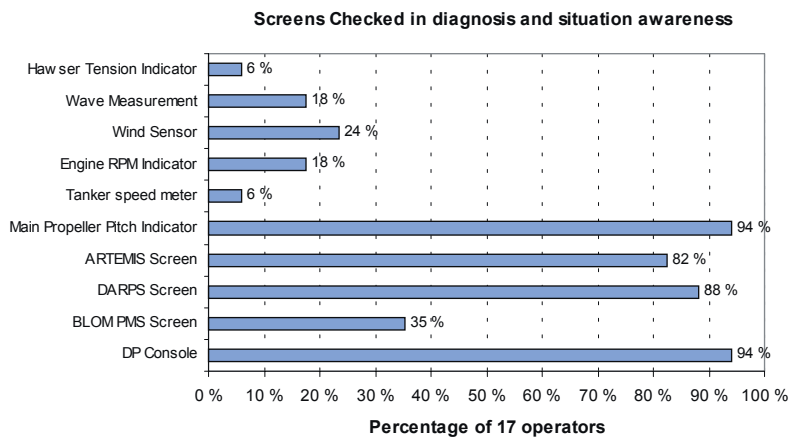

Figure 7-6 Checked screens in diagnosis and situation awareness

When using questionnaires, it is difficult to directly portray the experience and knowledge stored in the *long-term memory*, and the evaluating process that takes place in the *working memory*, for a DP operator in a drive-off scenario. However, those

contents may be reflected indirectly in the above findings from the *selective attention* and the *observation*. We have to note that an operator with more knowledge and experience is generally able to allocate his attention in a better way, and this speeds up the observation, and thus the necessary information to evaluate the hypotheses is quickly accessible in the working memory, and ultimately this leads to a quick and quality diagnosis.

7.6 MEASURES TO REDUCE DECISION TIME

Based on the theoretical model and the operational facts, three types of measures that may effectively reduce operator's time involved in diagnosis and situation awareness are identified.

- [1] Training - targeted to gain and accumulate knowledge and experience in the *long-term memory*, as well as to improve the evaluating process in the *working memory*.
- [2] Proceduralization – focused on best practice in the *selective attention* and *observation* process.
- [3] Automation – designed to keep track of the essential vessel data, aggregate evidence, and automatically diagnose (and intervene) if it is a drive-off situation.

7.6.1 Training

Extensive experience and practice in general help to achieve a better performance. As a necessary way to practice and accumulate experience, training has been used extensively to improve diagnosis and situation awareness. In both simulator training and onboard DP-play training, by given drive-off scenarios originated from various sources, a trainee may improve his ability of quick diagnosis and situation awareness significantly. For further information on training, see SMS (2000) and UKOOA (2002).

7.6.2 Proceduralization

Generally, proceduralization is a technique for outlining prescriptions of techniques that should be followed to improve the quality of decision-making (Bazerman, 1998). Specifically, given the time pressure in drive-off scenario in tandem loading, it will be beneficial if an emergency operation guideline (as proposed in Section 7.2 & 7.3) is issued to standardize operator attention on those data that are essential to drive-off diagnosis (Figure 7-4), and minimize the needed screen checks (Figure 7-5 and Figure 7-6). This is because the unfocused attention may result in more data checks that may contain unnecessary information, and ultimately require longer time in diagnosis.

Note that this emergency operation guideline is not designed to let the DP operator “read and then follow” in a time-critical drive-off scenario. Rather, it is to prepare the operator's mind for where to focus and what to check, should a drive-off occur. Further, the recommended actions should be practiced extensively during training so that they become a series of natural responses.

7.6.3 Automation

Computer automation is potentially a powerful tool to offer operators various types of support in the diagnosis process. At present, alarms in DP and BLOM PMS systems are set based on individual parameters, i.e., speed, position, and engine output (see Section 7.1). According to findings in the questionnaire survey, operators have to integrate tanker speed, position, and propeller pitch information together in order to diagnose the situation. It is therefore possible, by using the aggregated alarm concept (NPD, 2001), to design a drive-off detection system to assist the operator in diagnosis and situation awareness. This is in principle because when several units of information can be combined into one single meaningful representation, the human brain capacity required for handling this particular information will be reduced, and the brain will be able to handle more information effectively (NPD, 2001).

The drive-off detection system should ideally be designed as an aggregated alarm which takes input from the above three key data, i.e. (tanker) speed, position and heading relative to FPSO, and main propeller pitch. This aggregated alarm may preferably be imbedded in the BLOM PMS system, and it could function as a detector for a potential drive-off, rather than for a single abnormal parameter. Based on its internal algorithm, the drive-off detector can keep track of the three key data, analyze their trend, and aggregate evidence if one, two, or three of those data exceed the pre-defined range. Accordingly, recommendations to the operator may be given via a screen text and/or voice message, for example:

- If speed is increasing and over the limit, operator will be reminded to “notice the speed”.
- If speed exceeds the limit and the main propeller forward pitch is still increasing, the operator will be asked to notice the “early sign of drive-off, close situation monitoring, please!”
- If speed exceeds the limit, the main propeller forward pitch is continuously increasing, and distance to the FPSO is decreasing and finally reaches the short-distance warning limit, the operator will be informed that there is a “likely drive-off, full astern maneuvering, please!”.

After getting the above alarm messages, the operator should accordingly perform the suggested action within, e.g. 5-10 seconds.

Given this drive-off detector is implemented in the system, it may also be beneficial to further design a technical system that can automatically full-astern maneuver the tanker if there is no operator reaction within, e.g. 10 seconds after the “drive-off” alarm. This will be a technical barrier, in addition to the current human barrier, to prevent escalation from tanker drive-off scenarios.

8. CONCLUSIONS AND FUTURE WORK

Education is not what we have learned, but what we have left when we have forgotten what we have learned.

– ELLEN KEY

This chapter summarizes the conclusions of this Dr.Ing study and proposes directions for the future research. The conclusion is naturally divided into three areas: 1) probabilistic modeling of FPSO and tanker collision in tandem offloading, 2) evaluation/reduction of tanker drive-off probability, and 3) evaluation/reduction of failure probability of recovery initiated by the tanker DP operator. The future research is suggested in the following three levels. At *level I*, it is the supplementary modeling and analyses in the context of FPSO and tanker collision in tandem offloading. At *level II*, it is the application of the rationale behind the probabilistic model of the FPSO–tanker collision (which is the proposed operational safety modeling concept in Appendix A) in risk analyses of other similar marine operations. At *level III*, the challenge is to integrate generally the human element in offshore quantitative risk assessment methodology.

8.1 CONCLUSIONS

8.1.1 Modeling of FPSO-Tanker collision

An applicable probabilistic model of FPSO and tanker collision in the tandem offloading operation is developed. Theoretically this model is based on the proposed Operational Safety Modeling concept (see Appendix A), and practically it is built from the collected operational data. By a coarse evaluation of possible scenarios, a practical formulation of FPSO and tanker collision frequency is (Eq.2-2 in Chapter 2):

$$P/\text{Collision}() = P(\text{PFM}) \Delta P(\text{Failure of Tanker Initiated Recovery} | \text{PFM})$$

Evaluation, and ultimately reduction of FPSO and tanker collision probabilities in tandem offloading, as suggested in the above model, focuses on the following two stages in this study:

1. The *initiating* stage – Identify and minimize all possible sources and situations that may cause tanker drive-off forward.
2. The *recovery* stage – Evaluate and improve the recovery actions initiated by the tanker DP operator to avoid collision, should drive-off forward happen.

8.1.2 Probability of tanker drive-off

Tanker drive-off probability is portrayed by statistical data from an earlier study, recent SYNERGI incident data, and judgments made by tanker DP operators. A relatively high frequency of tanker drive-off in tandem offloading is found, likely ranging from 5.4E-03 to 2.0E-02 per loading, or 0.25 to 1 time per year if there are 50 tandem offloadings from FPSO annually.

The tanker drive-off scenario is investigated by examining nine such events in tandem offloading based on investigation reports, interviews and discussions with individuals who have direct or indirect information. It becomes clear that the initiation of tanker drive-off involves a complex human-machine interaction, typically involving DP hardware/software, position reference systems and vessel sensors, local thruster control system, and DP operator. A significant finding is the evidence of the failure prone situations, i.e. excessive relative horizontal motions between FPSO and tanker. It is during one or several combined modes of these excessive relative motions that a human-machine interaction process is initiated, e.g. by a technical failure event, or an operator action (though not necessarily an erroneous one), which eventually causes tanker drive-off. Among five collision incidents, four tanker drive-offs actually were initiated in this manner.

The failure prone situations, termed as excessive surging and yawing events in this study, are quantitatively analyzed based on simulated FPSO and tanker horizontal motions in a time-domain code SIMO. The simulation models are calibrated mainly based on the full-scale measurements. Three principle measures are identified to effectively minimize the excessive surging and yawing events, i.e. minimizing FPSO surge and yaw motions in offloading, coordinating mean heading between FPSO and tanker, and using the dedicated DP software with the tandem loading function on tanker. Ultimately, these measures may provide a sound operational environment where the probability of tanker drive-off can be minimized.

8.1.3 Probability of recovery failure

Recovery actions initiated by tanker DP operator in the drive-off scenario are studied. The allowable time for DP operator to initiate recovery action so that tanker can be stopped in a drive-off scenario within the present separation distance, e.g. 50-90 m to FPSO, is found to be critically short. Expert judgment by simulator trainer and questionnaire survey with shuttle tanker DP operators are conducted to estimate how much time is reasonably needed for tanker DP operator to initiate recovery action in a drive-off scenario. The estimates are found to converge with the facts in the incidents, and they imply that tanker DP operators in general need more time to initiate recovery

action than the allowable time window. In other words, recovery failure is likely due to lack of reaction time. Two principal recommendations are proposed accordingly, i.e. to increase the available time window and/or to reduce the operator reaction time.

To increase the available time window, a promising measure is to substantially increase of the separation distance between FPSO and tanker. The feasibility is confirmed from several perspectives, i.e. limited hardware modification, virtually no additional operational complexity, and positive opinions from operators. The gain is quantified and shows a over 50 % reduction of the recovery failure probability if distance is increased from 80 m to 120 m, and a 75 % reduction if the distance is increased from 80 m to 150 m. In practice, the separation distance between FPSO and tanker should be configured with dual considerations of tanker drive-off behavior and the time needed by the tanker DP operator to initiate recovery action, should a tanker drive-off occur. Doing so may lead to an optimum field configuration for the FPSO-tanker tandem offloading which inherently minimizes the collision risk.

Effective reduction of operator reaction time can be achieved by early detection and quick situation awareness. Proposed measures are built on the generic human signal detection and decision-making theory, and specifically designed for drive-off intervention based on the operational facts collected via the questionnaire survey. The use of speed alarms and their calibration for early detection of drive-off are emphasized. Potential measures to improve early detection of non-alarm signals are identified as: 1) to prevent DP operator fatigue, 2) to prevent interference from other concurrent activities around DP operator, and 3) to provide observation training. For the purpose of quick diagnosis and situation awareness, measures are identified as 1) to provide drive-off intervention training, 2) to issue an emergency operation guideline to standardize operators' attention on those data that are essential to drive-off diagnosis and minimize the needed screen checks, and 3) to design an automatic drive-off detection and intervention system to assist operator in detection, diagnosis/situation awareness, and recovery action execution. These measures may directly reduce the probability of FPSO-tanker collision in tandem offloading.

8.2 SUGGESTIONS FOR FUTURE WORK

8.2.1 Level I

The possible future research work at *level I* consists of the following modeling and analyses supplementary to the present work, in the context of FPSO and tanker collision in tandem offloading.

The probabilistic modeling of tanker drive-off scenario in Chapter 3 needs further development. The present model does point out the failure prone situations that need to be minimized. However, the area between the failure prone situations and the actual tanker drive-off has not yet been modeled, though we do see a strong link between the two, based on what had happened in the collision incidents. Risk reduction measures targeted in this area are lacking at present. However, unwanted failure prone situations

may nevertheless happen in the operation, and operators do need contingency plans in such situations.

Modeling of human-machine interaction involved in tanker drive-off in Chapter 3 also needs further development. The probabilistic model of tanker drive-off in principle takes into account three types of human action. However, the latent human action which may interact with technical failure as well as with the other two types of human action is not modeled. The latent human action has a vast span in terms of time and contents. It may occur in design, construction, installation, operation, and maintenance, and it involves front-line operators, maintenance personnel, and management teams. Modeling of the latent human action, and the human-machine interaction in general, therefore have to be based on an organizational point of view. Whether or not the probabilistic modeling can capture the subtle dependent relationship between various factors at various levels in a dynamic (not static) organization is a subject to debate. Other modeling techniques should be tested to see if they are applicable to the tandem offloading context.

The FPSO-tanker simulation models used in Chapter 4 may require some further work. Basically the thruster power limitations on both FPSO and tanker are not considered, i.e., both vessels have abundant positioning capacities. Subsequently, the environmental impact on vessel motion behavior is considered small and not studied in the sensitivity studies. However, in actual operation, there are positioning capacity limitations, especially on the tanker side. Environmental conditions, such as collinear vs. non-collinear wind-wave-current, abnormal current, sudden changes of wind direction, etc. will inevitably influence the surging and yawing events. The future simulation models should take these scenarios and the positioning capacity factor into account. It is also worth to note that the simulation models are calibrated to the North Sea conditions in terms of technical specifications, operational philosophies, and environmental conditions. Possible re-calibrations are needed if the models are used in other geographic locations.

8.2.2 Level II

The possible future research work at *level II* is to apply the rationale behind the probabilistic model of FPSO-tanker collision into the risk analyses of other similar marine operations. It is actually the application of the *Operational Safety Modeling* concept which is proposed in Appendix A. Similar marine operations may be considered as positioning operation of ships and/or floating platforms. A typical example may be the positioning of the DP drilling rig. In a broader scope, marine operations with similar dynamics of human supervisory control in the human-machine system are all applicable. Reference is made to Appendix A for details of the human supervisory control and human-machine system dynamics that are considered here.

An application example may in principle be outlined as follows. Note that detailed modeling requires a specific operational context, and the following are only generic discussions. Given a certain portion of the operational data that have been collected, scenarios that are breaching the designed performance limit may be identified and

evaluated. The modeling of a critical scenario can similarly be structured into the *initiating* stage and the *recovery* stage. The former models the occurrence of the scenario and analyzes the occurrence probability, and the latter models the scenario development and analyzes the system's recovery potential.

- It may still be possible, though not necessarily, to identify some failure prone situations where human-machine interaction happens which eventually leads to the critical scenario. Analyzing and minimizing those failure prone situations in the operation is where the risk analysis and reduction efforts should be placed first.
- Human operators may play a vital role in the recovery stage, though the technical system may also be involved. Operators' positive contributions should be identified and strengthened, while their negative impact should also be spotted and minimized.

Note that risk analyses typically focus on the negative contributions of human operators, i.e., the human error. This mind-set should be corrected. Humans are not placed in the system in order to bring in errors; in most cases they are actually the last safety barriers to save the situation. Without taking into account (and systematically analyzing) the positive human contributions, we will hardly know how to strengthen this last-safety-barrier in the operation. Constraints, which prevent operators from being able to do what they are supposed to do, may escape attention and continue to exist in the system. The existing time constraint (critically short) on tanker DP operator to intervene drive-off in tandem offloading is a typical example of this.

8.2.3 Level III

The future research work at *level III* is a vision of systematically integrating the human element in offshore quantitative risk assessment (QRA). This vision is by all means vague at present. The following thoughts serve as an early stage sketch.

The human element has been considered in QRA mainly in the consequence modeling, i.e., fatality (both individual and group) risk. However, there are rooms in other areas besides the consequence modeling, especially in the frequency modeling (and risk reduction area accordingly), where human contributions may be identified and taken into account. It is true that some component failure frequencies may have implicitly included human contributions occurred in design, operation, and maintenance. However, as revealed in this study, the frequency of FPSO and tanker collision in tandem offloading cannot be obtained without considering the potential human recovery failure, unless we directly assume that human recovery will fail. Then it is the tanker drive-off frequency that is 'conservatively' taken as the collision frequency. However risk analysis carried out in this manner will miss a whole area of potential risk reduction measures due to the incomplete modeling.

It is also true that if the human element is included, quantification becomes a very difficult task. Even if quantification is achieved, those large human failure probability numbers derived from subjective judgments or expert estimations are difficult to compare with the probability numbers derived from the technical area, not mention to

integrate both under some rule-of-thumb 10^{-4} annual frequency acceptance criterion. These are challenges. However, quantification is not the ultimate goal in offshore QRA, the ultimate goal is the risk reduction. Hard-to-quantify does not justify the reason to exclude human contributions in the modeling. And risk reduction can be made effective only when both positive and negative human contributions to the system have been assessed. Lessons learned in other safety-critical domains like the aviation industry will probably again pave the way for offshore QRA methodology to develop in the face of these challenges.

R E F E R E N C E S

- Addy PD, et al. Gryphon A, the first purpose built permanently moored FPSO in the North Sea. OTC 7424, Offshore Technology Conference, Houston, 1994.
- Andersen OJ. Environmental condition and ship motions during tandem offloading from FPSO (In Norwegian). Statoil internal report, 2000. [restricted]
- Bazerman M. Judgment in managerial decision making. 4th Ed., Wiley New York, 1998.
- Bea RG. Human and organization errors in reliability of offshore structures. Journal of Offshore Mechanics and Arctic Engineering, Vol. 119, February 1997.
- Blom. Data Preparation – XXXX FPSO & XXXX Tanker. Doc. 0214022-0200075, Rev.01, 2002a.
- Blom. Video re-construction of a collision incident between FPSO and tanker. 2002b.
- Chen H. SMS-Offshore Loading Phase 2: Information from Simulator Training Observation, 11.12.00 – 15.12.00. Restricted Internal Memo, Dept. of Marine Structures, NTNU, 2000.
- Chen H. FSU-Tanker Offloading Operation: Information from offshore trip. Restricted internal memo 03-07-01, Revision 24-07-01, Dept. of Marine Structures, NTNU, 2001.
- Chen H, Moan T, Haver S, and Larsen K. Predication of relative motions and probability of contact between FPSO and shuttle tanker in tandem offloading operation. OMAE2002-28101, Proceedings of the 21st OMAE Conference, Oslo, Norway, 2002a. [Under review by Journal of Offshore Mechanics and Arctic Engineering]
- Chen H and Moan T. Collision risk analysis of FPSO-Tanker offloading operation. OMAE2002-28103, Proceedings of the 21st OMAE Conference, Oslo, Norway, 2002b.
- Chen H and Moan T. Human intervention of tanker drive-off in tandem offloading operation. The 2nd International Conference on Human Factors in Ship Design and Operation, RINA HQ, London, UK, October, 2002c.
- Chen H. Captain and DP Officers Questionnaire Survey – Summary Report 21-05-2002. Dept. of Marine Structures, NTNU, 2002d. [restricted]
- Deaton JE and Parasuraman R. Effects of task demands and age on vigilance and subjective workload. Proceedings of the 32nd annual meeting of the Human Factor Society, Human Factor Society, 1988.

- DNMI (Tønnessen H). Hindcast data for Haltenbanken area. Norwegian Meteorological Institute, 1999.
- DNV. Environmental conditions and environmental loads. Classification Note 30.5, Det Norske Veritas, 1991.
- Dougherty EM and Fragola JR. Human reliability analysis: a systems engineering approach with nuclear power plant applications. Wiley, New York, 1988.
- DPVOA. Dynamic Positioning Systems Incidents, 1980-1992. Reference listed in the HSE report OTO 97055, 1994.
- Embrey DE. Incorporating management and organizational factors into probabilistic safety assessment. Reliability Engineering and System Safety, Vol. 38, pp. 199-208, 1992.
- Faber MH, Kroon IB, Kragh E, Bayly D, Decosemaeker, P. Risk assessment of decommissioning options using Bayesian Networks. Proceedings of the 20th OMAE Conference, Rio de Janeiro, Brazil, 2001.
- Fucatu CH, Nishimoto K, Maeda H, and Masetti IQ. The shadow effect on the dynamics of a shuttle tanker. OMAE2001/OFT-1132, Proceedings of the 20th OMAE Conference, Rio de Janeiro, Brazil, 2001.
- Fujita Y. Human reliability analysis: a human point of view. Reliability Engineering and System Safety, 38, pp71-79, 1992.
- Furnes O and Amdahl J. Computer simulation study of offshore collisions and analysis of ship-platform impacts. Applied Ocean Research, Vol. 2, No. 3, 1980.
- Fylling I, Stansberg CT and Mo K. Extreme motions and anchor line loads in turret mooring systems. Vol. 1, BOSS'92, 1992.
- Gudmestad K and Aanonsen G. (Kongsberg Simrad). Private communication regarding shuttle tanker thruster, main propeller and rudder information. Sept.-Nov., 2001
- Gudmestad K. (Kongsberg Simrad). Private communication regarding information of shuttle tanker propulsion. 2001
- Gudmestad OT. Risk assessment tools for use during fabrication of offshore structures and in marine operations projects. OMAE2001/S&R-2106, Proceedings of the 20th OMAE Conference, Rio de Janeiro, Brazil, 2001.
- Hannaman GW and Worledge DH. Some developments in human reliability analysis approaches and tools. Reliability Engineering and System safety, 22, 235-256, 1988.
- Hals T. Customer acceptance test procedure - Tandem Loading. Kongsberg Simrad, 2000. [restricted]

- Hals T. (Kongsberg Simrad). Private communication regarding tandem loading DP software, human intervention given DP failure in tandem loading. 2001.
- Hals T. (Kongsberg Simrad). Private communication regarding main propeller thrust reduction in tandem offloading. 2002.
- Hansen PF and Pedersen TP. Risk analysis of conventional and solo watch keeping. Dept. of Naval Architecture and Offshore Engineering, Technical University of Denmark, 1998.
- Haugen S and Moan T. Frequency of Collision between Ships and Platforms. Proceedings of the 11th OMAE Conference, Calgary, Canada, 1992.
- Heinrich HW. Industrial Accident Prevention. 4th Ed., pp4, McGraw-Hill Book Company, Inc., 1959.
- Helgøy K. (Navion ASA). Private communication regarding tandem offloading operations in the North Sea. February, 2002.
- Hollnagel E. Reliability analysis and operator modeling. Reliability Engineering and System Safety, 52, 327-337, 1996.
- Hollnagel E. Cognitive Reliability and Error Analysis Method – CREAM. ISBN 0-08-0428487, Elsevier Science Ltd., 1998.
- Hokstad P, Øien K and Reinertsen R. Recommendations on the use of expert judgment in safety and reliability engineering studies, two offshore case studies. Reliability Engineering and System Safety, 38, pp65-76, 1998.
- Hovde GO. Fatigue and overload reliability of offshore structural systems, considering the effect of inspection and repair. Dr.Ing Thesis, Dept. of Marine Structures, NTNU, 1995.
- HSE. Close proximity study. Offshore Technology Report - OTO 97055, Health & Safety Executive, UK, issued in 1997.
- HSE. Shuttle tankers and offloading operations at FPSO/FSUs. Offshore Technology Report - OTO 98172, Health & Safety Executive, UK, issued in 1999.
- Hurst R and L.R. (editors). Pilot Error. 2nd Ed., Aaronson, New York, U.S.A. 1982. The sentences was originally quoted in (Kletz, 2001).
- IMCA. Quantified frequency of shuttle tanker collision during offtake operations. IMCA Report M150, The International Marine Contractors Association, February 1999.
- IMCA. Failure Modes of CPP Thrusters. Reference listed in the HSE report OTO 97055, 1995.

- Ingstad O and Bodsberg L. CRIOP: A Scenario-method for Evaluation of the Offshore Control Center. SINTEF Report No. STF75 A89028, 1990.
- Inoue Y and Islam MR. Relative motions of multiple floating offshore structures. OMAE99/OFT-4192, Proceedings of the 18th OMAE Conference, Newfoundland, Canada, 1998.
- Jung WD, Yoon WC, and Kim JW. Structured information analysis for human reliability analysis of emergency tasks in nuclear power plants. Reliability Engineering and System Safety, 71, 21-32, 2001.
- Kletz T, Chung P, Broomfield E, and Shen-Orr C. Computer control and human error. ISBN 0 85295 362 3, IChemE, 1995.
- Kletz T. Learning from Accidents. 3rd Ed, pp.7, ISBN 0 7506 4883 X, Gulf Professional Publishing, 2001a.
- Kletz T. An Engineer's View of Human Error. 3rd Ed., ISBN 1-56032-910-6, Institution of Chemical Engineers, 2001b.
- Kirwan B. A guide to practical human reliability assessment. ISBN 0-7484-0052-4, Taylor & Francis, 1994.
- Kvitrud A, Ersdal G, and Leonhardsen RL. On the risk of structural failure on Norwegian offshore installations. Proceeding of the 11th ISOPE Conference, Vol. IV, Stavanger, Norway, 2001.
- Lao Tzu (571 BC). Tao Te Ching. Translated by Arthur Waley, ISBN 1853264717, Wordsworth Editions Ltd., 1997.
- Leonhardsen RL, Ersdal G, Kvitrud A. Experience and risk assessment of FPSOs in use on the Norwegian Continental Shelf: Description of events. Proceeding of the 11th ISOPE Conference, Vol. I, Stavanger, Norway, 2001.
- MacDonald A, et al. Collision Risks Associated with FPSOs in Deep Water Gulf of Mexico. OTC 10999, Offshore Technology Conference, Houston, 1999.
- Macwan A and Mosleh A. A methodology for modeling operator errors of commission in probabilistic risk assessment. Reliability Engineering and System Safety, 45, pp139-157, 1994.
- Marintek. FPSO motion model test results. Report excerpts received from Statoil, 1994 & 1999.
- McCaul JR. Special Report – Floating Production Systems. Oil & Gas Journal, June 11, 2001.

- Morandimi C, Legerstee F, Francois M, and Raposo CV. Numerical analysis of FPSO offloading operations. OMAE2001/OFT-1002, Proceedings of the 20th OMAE Conference, Rio de Janeiro, Brazil, 2001.
- Morishita HM, Souza Junior JRD, Cornet BJJ. Nonlinear Dynamics of a FPSO and Shuttle vessels in Tandem Configuration. Proceedings of the 11th ISOPE Conference, Vo. I, Stavanger, Norway, 2001.
- Murphy DM and Pate-Cornell ME. The SAM Framework: Modeling the Effects of Management Factors on Human Behavior in Risk Analysis. Risk Analysis, Vol. 16, No. 4, 1996.
- Navion. Training requirements for shuttle tanker and conventional tanker personnel. Valid from 1998, NAV/KR-508, 1997.
- Navion. DP guidelines. Rev. date 22.04.99, NAV/RD-556 (E), 1999.
- NTS. Action and action effects. NORSOK Standard N-003, Rev.1, 1999.
- NTS. Design of Steel Structures – Annex L Special Design Provisions for Ship Shaped Units. NORSOK Standard N-004, Rev. 1, 1998.
- NPD. Principles for alarm system design. Norwegian Petroleum Directorate, 2001.
- NPD. Guidelines to Regulations Relating to Conduct of Activities in the Petroleum Activities (The Activities Regulations). Chapter XIV, Section 81. 2002.
- Odland J. The Norne Production Ship – Design Considerations. OTC 7926, Offshore Technology Conference, Houston, 1995.
- Ormberg H and Larsen K. Coupled analysis of floater motion and mooring dynamics for a turret-moored ship. Applied Ocean Research 20, 55-67, 1998.
- Parry GW. Suggestions for an improved HRA method for use in probabilistic safety assessment. Reliability Engineering and System Safety, 49, 1-12, 1995.
- Pyö P. An approach for assessing human decision reliability. Reliability Engineering and System Safety, 68, 17-28, 2000.
- Rasmussen J. Information processing and human-machine interaction, An approach to cognitive engineering. ISBN 0-444-00987-6, Elsevier Science Publishings, 1986.
- Reason J. Human Error. ISBN 0-521-31419-4, Cambridge University Press, 1990.
- Reason J. Managing the Risks of Organizational Accidents. ISBN 1 84014 104 2, Ashgate Publishing Co., 1997.
- Reinholdtsen SA and Falkenberg E. SIMO – Theory / User Manual. MT51 F93-0184, MARINTEK, 2001.

- Rosness R. Risk Influence Analysis, A methodology for identification and assessment of risk reduction strategies. *Reliability Engineering and System Safety*, Vol. 60, pp. 153-164, 1998.
- Sheridan TB. *Telerobotics, automation, and human supervisory control*. ISBN 0-262-19316-7, MIT Press, 1992.
- Skallerud B and Amdahl J. *Nonlinear Analysis of Offshore Structures*. Research Studies Press Ltd (to be published), 2002.
- Skjong R and Wentworth BH. Expert judgment and risk perception. *Proceedings of the 11th ISOPE Conference*, Vol. IV, Stavanger, Norway, 2001.
- Smidts C, Shen SH, and Mosleh A. The IDA cognitive model for the analysis of nuclear power plant operator response under accident conditions, Part I: Problem solving and decision making model. *Reliability Engineering and System Safety*, 55, 51-71, 1997.
- SMS. *Offshore loading phase 2, course material*. Ship Manoeuvring Simulator Centre AS, Trondheim, 2000. [Restricted]
- Sphaier SH, Fernandes AC, Correa SHS, and Castro GAV. Maneuvering model for FPSOs and offloading analysis. OMAE2001/OFT-1303, *Proceedings of the 20th OMAE Conference*, Rio de Janeiro, Brazil, 2001.
- Statoil. *Granskningsrapport fra berøring*. Document No. 00A05*0209, 2000.
- Tveit OJ. Risk management approach to FPSOs in Statoil. Presentation in Bechtel Offshore; FPSO Symposium for the JIP on Risk Assessment and Reliability of a FPSO System in the Gulf of Mexico, Houston, 9-10.3.1998.
- Tønnessen LI. (Navion ASA). Private communication regarding a shuttle tanker crash-stop test information. 2001.
- Tønnessen LI. (Navion ASA). Private communication regarding a tanker tandem offloading numbers in late 1990s. 2002.
- UKOOA. *Tandem Loading Guidelines, Vol.1 FPSO/Tanker Risk Control During Offtake*. Rev. B, UKOOA FPSO Committee, 2002.
- Vinnem JE. *Offshore Risk Assessment – Principles, Modeling and Applications of QRA studies*. PP393, ISBN 0-7923-5860-0, Kluwer Academic Publishers, 1999.
- Vinnem JE. *Operational safety of FPSOs: Initial summary report*. OTO 2000/86, Offshore Technology Report, Health & Safety Executive, UK, 2000.
- Wickens CD and Flach JM. *Information Processing*. In Wiener EL and Nagel DC (eds.) *Human Factors in Aviation*. ISBN 0-12-750030-8, Academic Press, Inc., 1988.

Wickens CD and Hollands JG. Engineering Psychology and Human Performance. 3rd Ed., ISBN 0-321-04711-7, Prentice-Hall Inc., 2000.

A P P E N D I X

A. THEORETICAL BACKGROUND

This appendix provides the rationale behind the collision frequency model presented in Chapter 2. The tandem offloading operation is carried out through a joint human-machine system where human supervisory control is involved. The basics of the human supervisory control and the dynamics of the human-machine system are discussed. The operational safety modeling (OSM) concept is then proposed based on the adapted offshore quantitative risk analysis methodology. The constructed collision frequency model is an application of this OSM concept. In addition, this appendix also includes the basics of human actions and human errors, since these are bottom blocks for evaluating human reliability in a human-machine system. Theoretical evidences and operational facts make it clear that the modeling in Chapter 3 and Chapter 5 should focus on ‘human actions’ instead of various types of ‘human errors’. The last part of this appendix deals with human information processing models. These can be viewed as support to the proposed model for DP operator action initiation in Chapter 5.

A.1 RATIONALE BEHIND THE COLLISION FREQUENCY MODEL

The FPSO and shuttle tanker tandem offloading operation is carried out through a joint human-machine system. For those who are new to the tandem offloading operation, they are suggested to read the Appendix D first. Operational safety analysis of tandem offloading in general, and modeling of the collision between FPSO and tanker in the operation in particular, require that the basics of this joint human-machine system are adequately understood. I therefore start with the human supervisory control concept which is involved in the human-machine system in the tandem offloading context. Afterwards the dynamics of human-machine system are discussed, and their implications, combined with the adapted offshore quantitative risk analysis approach, provide the basic formulation of the collision frequency model presented in Chapter 2.

A.1.1 Human supervisory control

Human supervisory control is defined by Sheridan and Hennessy (1984) as “initiating, monitoring, and adjusting processes in systems that otherwise automatically controlled”. The human supervisory control, compared to manual control and full automation is shown in Figure A - 1 (Sheridan, 1992).

In manual control, operators employ direct sensing and manipulation. Computers may be an aid in either or both sensing and acting. However, all control decisions depend on the human operator. In supervisory control, a minor or a major fraction of control is accomplished by control loops closed directly through the computer and exclusive of the human. Specifically in tandem offloading operation, the third figure from the left may be applicable to the *Approach*, *Connection*, *Disconnection* and *Departure* phases, while the fourth one is applicable to the *Loading* phase. In full automatic control, the human operator can observe but cannot influence the control process.

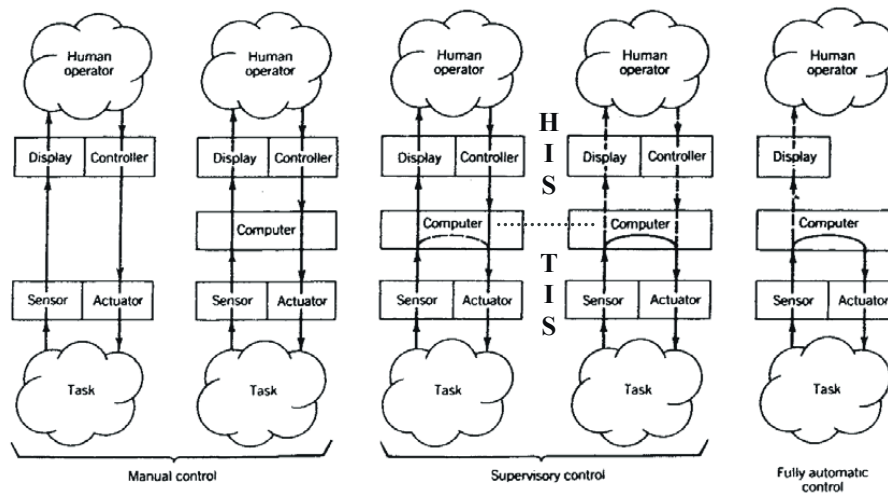

Figure A - 1 Manual, supervisory, and full automatic control (Sheridan, 1992)

The basic features of human supervisory control may be described as follows based on Moray (1986). In the lower level there is a task-interactive system (TIS). This exercises closed-loop control over the hardware components of the task (e.g. propellers and engines) through automatic subsystems (e.g. DP software). The TIS can trim the system to predetermined set points, but it is not able to adjust these set points or initiate any kind of adaptive response. The TIS is controlled by the human-interactive system (HIS) which comprises the upper level of the control hierarchy. The HIS communicates the state of the system to the operator through its displays. It also receives commands from the operator regarding new goals and set points. Its intelligence lies in the fact that it can use its stored knowledge to issue tactical commands to the TIS that will optimize various performance criteria.

It is now primarily the computer rather than the human becomes the central controller. Despite the fact that the human defines the goals for the computer, the latter is in control (Moray 1986). Most of the time, the operator's task is reduced to that of monitoring the system to ensure that it continues to function within normal limits. However, the main reason to keep the operator in the system is that s/he has the unique power of

knowledge-based reasoning which can be used to cope with system emergencies, and/or to do tasks which designers do not know how to automate.

There are several difficulties at the heart of human supervisory control. For example, operators are required to monitor that the system functions properly. It is well known that even highly motivated operators cannot maintain effective vigilance for anything more than quite short periods, thus they are actually ill-suited to carry out the task of monitoring for rare and abnormal events (Reason, 1990). Another example is regarding one of tasks that justify operators' existence in the system, i.e. operator is supposed to take over manual control when the automatic control system fails. Manual control is a highly skilled activity, and skills must be practiced continuously to be upheld. However, an automatic control system that fails only rarely denies operators the opportunity for practicing these basic control skills. Moreover, when manual takeover is necessary, something usually has gone wrong. This means that operators need to be more rather than less skilled in order to cope with these abnormal conditions (Reason, 1990).

A.1.2 Human-Machine system dynamics

Operational safety analyses of tandem offloading require that the dynamics of this joint human-machine system in the operation be adequately understood. The following discussions based on Hollnagel (1996) are considered applicable to the present study.

If it can be assumed that the joint system will perform as expected and remain within the envelope of design performance, then there may be no need to go beyond a technologically based description. The operators act as regulators (although as more complex regulators than those which can be designed), but since their performance remains within the prescribed band, there is no need to model them differently from how a technical regulator is modeled.

However, it is likely that the system will encounter situations where human performance begins to play a separate role, then there is a need to understand it in its own term. This is the case both when human actions are seen as the root cause(s) or triggering causes of unwanted system events, and when human actions are seen as the events that save the system.

The above human-machine system dynamics implies that there are two main issues to be addressed in the operational safety modeling in general.

1. To predict what could possibly go wrong so that the joint human-machine system will perform outside the design envelope. All types of causes, e.g., operation actions, technical system failures, measurement and instrumentation failures, and so on, have to be included and evaluated.
2. To assess the system's recovery ability when outside the design performance envelope. The human operator plays a separate role here, and both the technical system and human operator have to be taken into account when assessing the system's recovery ability.

A.1.3 Operational safety modeling

The operational safety of human-machine systems with human supervisory control may be modeled based on the adapted offshore quantitative risk analysis approach. The proposed operational safety modeling (OSM) is formulated in the light of the human-machine system dynamics described above. The analytical elements in OSM are schematically shown as a bow-tie-diagram in Figure A - 2. This figure is adapted from Vinnem (1999).

In the offshore quantitative risk analysis, the starting point is the identification of initiating events. This involves a broad review of possible hazards and sources of accidents to ensure that no relevant hazards are overlooked. The cause analysis (left) is to identify causes that may lead to the initiating events and quantify probabilities of the initiating events. The fault tree analysis is a typical tool. The consequence analysis (right) comprises modeling of accident sequences and analyzing the consequences, in terms of personnel fatality, damage to environment, and assets loss. The even tree analysis is often used.

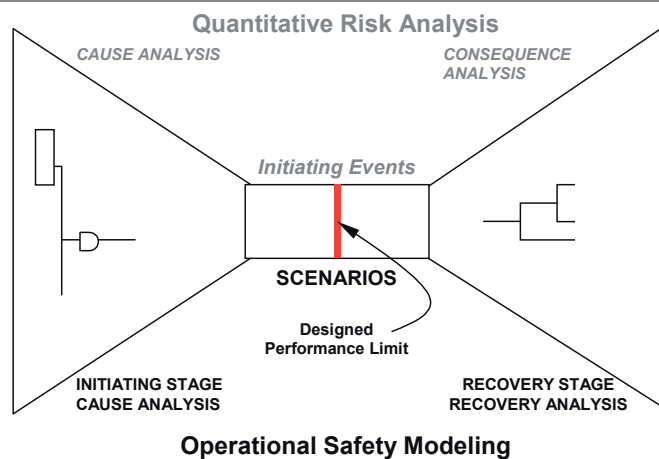

Figure A - 2 Analytical elements in the proposed operational safety modeling

In the proposed operational safety modeling, the starting point is to identify scenarios which may cause the system to go outside the designed performance limit. On the left hand side is the initiating stage, where cause analysis of scenario is carried out to model the event paths that may lead to the scenario and quantify the probability of the scenario. Due to human-machine interactions involved, modeling the event paths that potentially lead to the scenario can be a very challenging task. On the right hand side is the recovery stage, where recovery analysis is carried out to model the sequences of scenario development and assess the system's recovery ability – which should take into account both technical reliability and human reliability. Note that safety analyses have predominantly considered *human* to be an unreliable element. Instead of trying to improve/reinforce the reliability of human performance, there has been an explicit goal

to remove the human by increasing automation or reducing human role as far as is possible. These solutions are far from satisfactory, and actually cause the difficulties discussed in Section A.1.1.

The proposed OSM is applied to model the collision in tandem offloading, as has been presented in Chapter 2. In the following, human action, error and reliability issues are discussed concerning detailed applications of the operational safety modeling in the present study.

A.2 HUMAN ACTION, ERROR, AND RELIABILITY

There are tons of books and papers on human reliability and related areas. We may also safely say that each book or paper dealing with the human reliability has its original context, in terms of technical system, operator, organization, etc. It is not my objective to write a review of 'human reliability' that covers every (or most) major issue under this heading. Readers are directed to Ch.1 and Ch.4 in Kirwan (1994) and Ch.1 and Ch.2 in Hollnagel (1998) for a quick grasp of 'generic' theories and principles regarding human reliability. In this study I have a unique context to consider, i.e. shuttle tanker tandem offloading from FPSO.

The collision frequency model presented in Chapter 2 has directed our attention to the scenario of tanker powered forward movement (drive-off). On the 'left' side, human operators are involved in the initiation of tanker drive-off. On the 'right' side, there is the recovery ability of the joint human-machine system in which the human operator plays an indispensable role. The human reliability issues addressed in this section are closely related to the two areas of interest outlined above. I focus on the basics of human actions and human errors, since these constitute the fundament for evaluating human reliability in a human-machine system. Theoretical evidences in this section guide the operational safety modeling in Chapter 3 and Chapter 5 to three types of 'human actions', i.e. initiating action, response action, and latent action, rather than to various types of 'human errors'.

A.2.1 Human action

The human actions involved in a human-machine system may be characterized by the skill-, rule-, and knowledge-based behavior as presented in Figure A - 3. This is theoretically according to Rasmussen's skill-rule-knowledge framework (Rasmussen et al., 1981).

The skill-based behavior denotes human actions that are controlled by the stored patterns of behavior. The operator reacts to stimuli with little conscious effort or consideration, and acts in an automatic mode.

Rule-based behavior involves using stored or readily available rules in familiar settings. The operator firstly needs to recognize the necessity of applying rules rather than just reacting automatically, and secondly select appropriate rules and execute action.

Knowledge-based behavior is event-specific, and is based on a functional understanding of what is happening in the system when a demand is placed on the operator. This level of behavior involves higher-level cognitive processes – identification of system status, decisions based on goals such as production, safety, etc., and task planning. The planned task calls upon rule-based behavior for stored procedure and skill-based behavior for execution of the task.

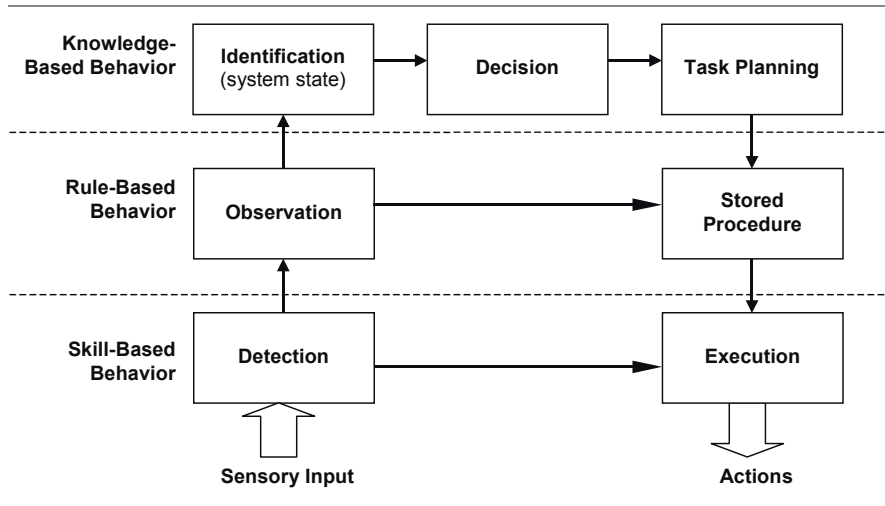

Figure A - 3 Skill, Rule, and Knowledge based behavior (from Rasmussen *et al.*, 1981)

A.2.2 Human error

There are many definitions and classifications of ‘human error’. Each reflects its own practical concern and theoretical orientation. The contents of this section are mainly from Reason (1990) due to its psychological merit and the general practicability.

The term ‘human error’ is defined by Reason (1990) as follows:

Errors will be taken as a generic term to encompass all those occasions in which a planned sequence of mental or physical activities fails to achieve its intended outcome, and when these failures cannot be attributed to the intervention of some agency. (Page 9).

Reason emphasizes that the notions of intention and error are inseparable. Human action can be categorized as intentional action and nonintentional action. Reason argues that human error is only associated with the intentional action, and it has no psychological meaning in relation to nonintentional behavior. This view is also accepted here; although, from safety point of view, nonintentional human behavior may contribute to system failure too.

The notion of intention comprises two elements: 1) an expression of the end-state to be attained; and 2) an indication of the means by which it is to be achieved. Subsequently, the human error types are dependent on two kinds of failure:

1. Failure of actions to go as intended – slips and lapses
2. Failure of intended actions to achieve their desired outcomes – mistakes

Slips and lapses are errors that result from some failure in the execution and/or storage of an action sequence. Slips are potentially observable as actions-not-as-planned, and lapses largely involve failures of memory which do not necessarily manifest themselves in actual behavior and may not be apparent to the person who experiences them. These two types of error occur at the skill-based behavior level in Figure A - 3.

Mistakes are errors that result from deficiencies or failures in the judgment and/or inferential processes involved in the selection of an objective or in the specification of the means to achieve it. It is likely that mistakes are more complex, subtle and harder to detect than slips and lapses. Mistakes may happen in both the rule-based and knowledge-based behavior level as shown in Figure A - 3.

To count another important way in which humans contribute to system failure, the term ‘violation’ is defined by Reason (1990) as follows:

Deliberate – but not necessarily reprehensible – deviations from those practices deemed necessary (by designers, managers and regulatory agencies) to maintain the safe operation of a potentially hazardous system. (Page 195)

The necessity of defining ‘violation’ relates to the fact that the term ‘human error’ is defined within the cognitive processes of the individual. However, we know that human actions also occur in social contexts in which human behavior is governed by rules, procedures, and the like. The violation phenomena may range from a short cut during a procedure, corner-cutting of the operation, to purposely turn off safety devices for other purposes, or someone trying to test how far the system can be pushed in a normal operation mode. Human error and violation may be present together, but they may also occur independently. As commented by Reason (1990), one may err without committing a violation; a violation need not involve error.

A.2.3 Human reliability

Human reliability, generically as defined by Swain (1990), is the success probability of human activities of which failure are likely to give significant impact on the reliability of a human-machine system. Note that this definition does point out that it is certain human activities that are of interest, and failure of these activities will impact reliability of the whole human-machine system. However, as argued by Fujita (1992), a human cannot be assumed to be just a component which only carries out whatever task the designers assign to it. Instead, human beings are agents which act on their own intentions. We therefore see human activities which do not fail, but nonetheless damage

the reliability of the whole system. These reasons lead to the following scope of human reliability analyses in this study.

Analyses of human reliability in this study consist of modeling and analyzing human contributions to the initiation of tanker drive-off and to the recovery operation if tanker drive-off happens. In the early stages of this study, the modeling attempts were almost solely focused on human errors and violation. The assumption was that the interested human contributions would solely be from these two categories, as defined in Section A.2.2. After all, it seems to be generally accepted that about 80% of offshore accidents are due to human error, and 80% of those occur during operations. However, there are different interpretations of what have been included under the label of 'human error' in that assertion. Human errors, i.e., slips, lapses, and mistakes, and of course violations, do contribute to the initiation and recovery of tanker drive-off. However, other human actions may also contribute.

The following is a real example (also briefly described in Chapter 3) showing how a human action (neither error nor violation type) may contribute to the initiation of tanker drive-off. During offloading, the DARPS (Differential Absolute & Relative Position System) unit generated an erroneous signal due to interference. Afterwards the DARPS signal was de-selected automatically from DP. Based on procedure¹, the operator re-selected the DARPS signal into DP when the signal was observed normal. This re-selection action had been done a few times already since DARPS interference had occurred a few times. However, during this re-selection process the interference occurred again, and the erroneous position signal, due to operator's re-selection, was accepted by DP, and subsequently the tanker was driven forward based on the wrong distance calculated by DP. In this event, the operator's action went on as intended, and the goal, i.e. re-selection of the DARPS signal into DP, was achieved too. There was no human error involved, and the action was according to the procedure too, i.e., no violation either. However, we do see that the operator's action contributed to the initiation of tanker drive-off.

The above case exemplifies what Murphy and Pate-Cornell (1996) have commented on; i.e., that there are gray areas in which the distinction between error and appropriate action is unclear in a complex system, when for instance goals conflict or the operator lacks information. We may also note the dynamic nature of such complex systems, which causes the same action to be at one time appropriate while at other times initiating a drive-off event.

It is clear that focusing on modeling of human error and violation in this study may potentially rule out other possible human contributions. This is a modeling challenge. As an initial step, human actions, regardless of whether they are errors, violations, or gray actions, are considered in the modeling. Given the nature of the human supervisory control involved, and the dynamics of the considered human-machine system as

¹ The operational procedure requires that minimum three position reference signals during tandem offloading.

described in Section A.1, the human actions are generalized into the following three types in this study:

1. Initiating action – An action initiates a failure event.
2. Response action – An action is a response to system demands, typically during technical failure events or special external situations. It may save or worsen the situation or cause a transition to another event.
3. Latent action – An action influences the status (failure probability) of technical system components, e.g. maintenance action, and potentially interacts with the above two types of human actions.

The resulting probabilistic models of tanker drive-off are presented in Chapter 3. Assessing and reducing human contributions are carried out in the light of the failure prone situation concept.

A.3 HUMAN INFORMATION PROCESSING MODELS

The objective is to reasonably model the reaction from DP operator during the tanker drive-off scenario. To achieve this objective, lessons learned from operator models developed in other similar context should be taken into account. This is the motivation to include this section in the theory appendix.

The most pervasive model of humans in human-machine systems is probably the Stimulus-Organism-Response paradigm. The human operator is located in the middle, as “Organism”, receiving “Stimulus”, and performing “Response”. This view is largely accepted in the context in this study. As Dougherty (1993) stated, the concern is how to handle the immense richness of the “O” in S-O-R paradigm that makes human versus machine performance so interesting. A few operator models based on the S-O-R model in human reliability studies are briefly outlined.

Taking a closer look at the “O” in S-O-R, the human can be viewed as an Information Processing System. According to this view, human cognitive processes could be broken down to several (not necessarily sequential) procedures and mental states which are linked by their causal relations with sensory input, muscle behavior, and other mental states. This view is considered valid in the context in this study. Two typical examples, i.e. the step-ladder model for process plant operators by Rasmussen (1986) and Wickens’ model for aviation pilot by Wickens and Flach (1988), are briefly presented below. These models form the foundation for the proposed Information-Decision-Execution model for tanker DP operator in drive-off scenario in Chapter 5.

A.3.1 S-O-R models

In early 1980s, the SHARP (Hannamann & Spurgin, 1984) approach suggested a decomposition of human actions into: observation, diagnosis, and manual actions, after

an initiating event. This type of analysis later became common in many human reliability methods.

Nagel (1988), in his safety study of human error in aviation operations, proposed a three-stage human action model: information, decision, and action. He argued that most purposive, skilled behavior in a somewhat constrained environment like the airplane cockpit can reasonably be described in terms of the simple 3-stage model of behavior as follows.

- Information stage: acquisition, exchange, and processing of information.
- Decision stage: decisions are made and specific intents or plans to act are determined.
- Action stage: decisions are implemented and intents acted upon.

Smidts et al. (1997) set up a cognitive model (IDA) for the analysis of the nuclear power plant operator response under accident conditions. The model of the single operator consists of three major components:

- Information Module
- Problem Solving / Decision Making Module (PS / DM)
- Action Module

Kontogiannis (1997) proposed a framework for the analysis of cognitive reliability in complex systems. The author included the following human information processing stages: interpretation, decision-making, and task planning.

- Interpretation – situation assessment. When a problem occurs, operators have to assess the situation in terms of system functions no longer available, and underlying causes.
- Decision-making – refers to the selection of a task goal to compensate for the problem and entails a comparison of different problem solutions in terms of a set of evaluation criteria.
- Task planning or scheduling – is required in order to formulate a sequence of actions based on a set of problem constraints identified in the decision making stage.

The linear fashion of some of the models above cannot account for the shortcuts that human decision makers take in a real-life situation. Instead of a straight-line sequence of stages, Rasmussen proposed a model analogous to a step-ladder. This is discussed in the following subsection.

A.3.2 Step-ladder model

For control of a physical system such as in industrial process plant, Rasmussen (1986) proposed a human information processing model which includes the following eight

stages: activation, observation, identification, interpretation, evaluation, task selection, procedure selection, and execution, as presented in Figure A - 4.

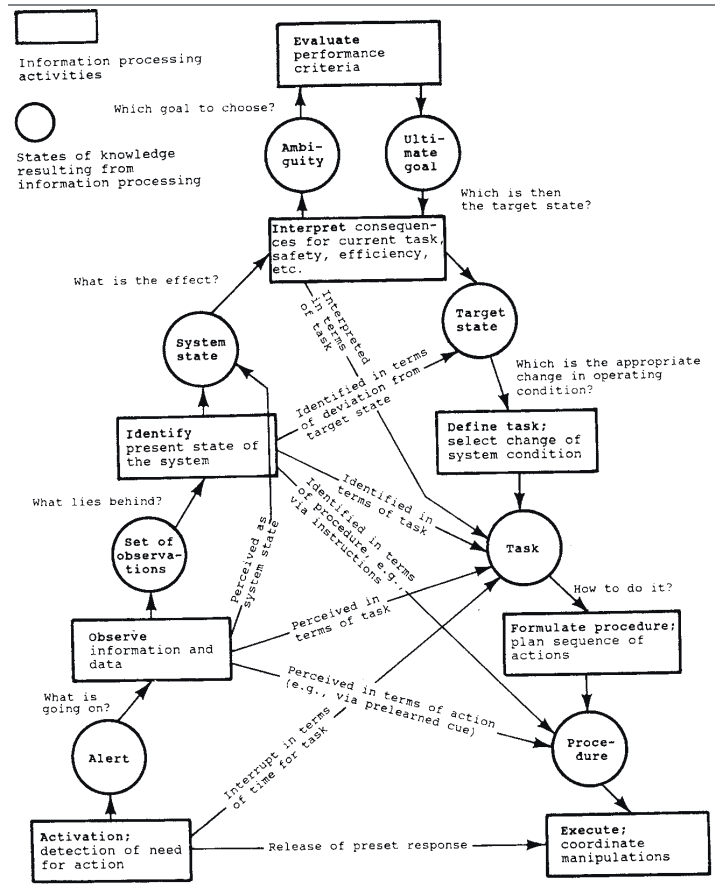

Figure A - 4 Step-ladder model (Rasmussen, 1986)

The following explanation is provided, assuming a simple example (Rasmussen, 1986). First, the operator has to DETECT the need for intervention, and has to look around and OBSERVE some important data in order to have direction for subsequent activities. He or she then has to analyze the evidence available in order to IDENTIFY the present state of affairs, INTERPRET the consequences of current tasks, safety, efficiency, etc., and to EVALUATE their possible consequences with reference to the established operational goals and company policies. Based on evaluation, a target state into which the system should be transferred is chosen, and the TASK that the decision maker has to perform is selected from a review of the resources available to reach the target state. When the task has been identified, the proper PROCEDURE, i.e., how to do it, must be planned and EXECUTED.

A.3.3 Wickens' model

Wickens and Flach (1988) proposed the following information processing model for aviation pilots. It consists of the following main processes: sensory store, pattern recognition, decision and response selection, and response execution, as presented in Figure A - 5.

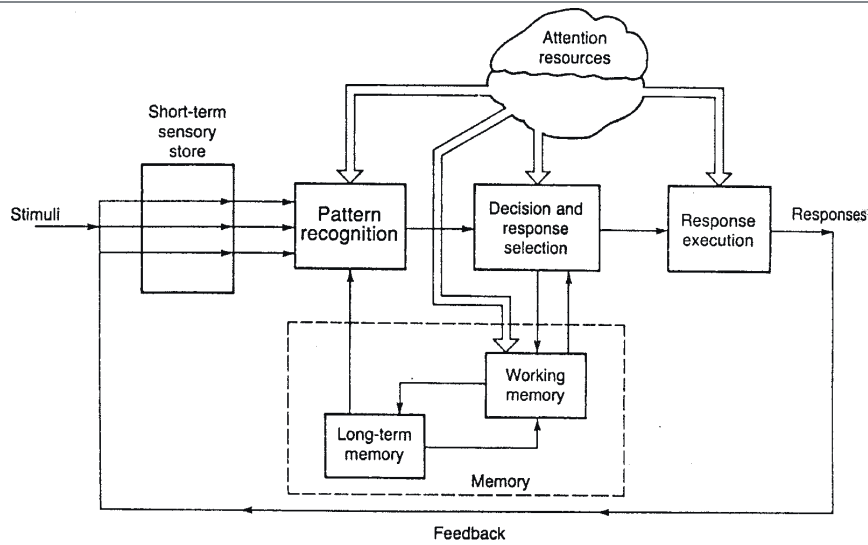

Figure A - 5 Wickens' human information processing model (Wickens & Flach, 1988)

The first stage in the model is the sensory store. In sensory store, physical energy is transformed into neural energy. Information is represented in the sensory store in terms of physical features.

The second stage, pattern recognition, is probably the most important yet least understood of all the stages. It is at this stage that the physical stimulation in the sensory stores is integrated into meaningful elements. This pattern recognition process involves mapping the physical codes of the sensory store into meaningful codes from memory. This mapping is very complex in that many different physical codes may all map to a single memory code and a single physical code may map to different memory codes. Perceptual processes are often limited by the supply of attention resources.

The next stage is the decision and response selection stage. At this stage, a stimulus has been recognized and a decision must be made as to what to do with it. A number of options are available at this point. The information can be stored for future use, it can be integrated with other available information, or it may initiate a response. Each of these options will generally be associated with potential costs and benefits which must be considered when choosing among them.

The last stage, response execution, interprets what may be a generally specified intention into precisely sequenced muscle commands. The resulting responses, by way of the feedback loop, then become input to the sensory stores, which can be interpreted and entered as data relevant to selecting the next response.

In addition to the processing stages, the human action model contains three ways to store information: sensory store (mentioned earlier), working memory, and long-term memory. Working memory represents the information currently being used by the information processor. Long-term memory represents information available to the information processor, but not currently in use. Long-term memory is the storehouse of all accumulated knowledge.

A.4 REFERENCES

Dougherty E. Context and human reliability analysis, *Reliability Engineering and System Safety*, 41, 25-47, 1993.

Fujita Y. Human reliability analysis: a human point of view. *Reliability Engineering and System Safety*, 38, 71-79, 1992.

Hannamann G, and Spurgin A. A systematic human action reliability procedure (SHARP). NUS Corporation, EPRI, NP-3583, 1984.

Hollnagel E. Reliability analysis and operator modeling. *Reliability Engineering and System Safety*, 52, 327-337, 1996.

Hollnagel E. *Cognitive Reliability and Error Analysis Method – CREAM*. ISBN 0-08-0428487, Elsevier Science Ltd., 1998.

Kirwan B. *A guide to practical human reliability assessment*. ISBN 0-7484-0052-4, Taylor & Francis, 1994.

Kontogiannis T. A framework for the analysis of cognitive reliability in complex systems: a recovery centered approach. *Reliability Engineering and System Safety*, 58, 233-248, 1997.

Moray N. Monitoring behavior and supervisory control. In Boff K, Kaufman L, and Thomas J. (Eds.) *Handbook of perception and human performance* (vol. 2). Wiley, New York, 1986.

Murphy DM and Pate-Cornell ME. The SAM Framework: Modeling the Effects of Management Factors on Human Behavior in Risk Analysis. *Risk Analysis*, Vol. 16, No. 4, 1996.

Nagel DC. Human error in aviation operations. In Wiener EL and Nagel DC. (Eds.). *Human Factors in Aviation*, ISBN 0-12-750030-8, Academic Press, Inc., 1988.

Rasmussen J, Pedersen OM, Carnino A, Griffon M, Mancini C, and Gagnolet P. Classification system for reporting events involving human malfunctions. Report Riso-M-2240, DK-4000, Riso National Laboratories, Denmark, 1981.

Rasmussen J. Information processing and human-machine interaction, An approach to cognitive engineering. ISBN 0-444-00987-6, Elsevier Science Publishings, 1986.

Reason J. Human Error. ISBN 0-521-31419-4, Cambridge University Press, 1990.

Sheridan TB. Telerobotics, automation, and human supervisory control. ISBN 0-262-19316-7, MIT Press, 1992.

Sheridan TB and Hennessy RT. (Eds.). Research and modeling of supervisory control behavior. National Academy Press, Washington, D.C., 1984.

Smidts C, Shen SH, and Mosleh A. The IDA cognitive model for the analysis of nuclear power plant operator response under accident conditions, Part I. Problem solving and decision making model. Reliability Engineering and System Safety, 55, 51-71, 1997.

Swain AD. Human reliability analysis: Need, Status, Trends and Limitations. Reliability Engineering & System Safety, 29, 301-313, 1990.

Vinnem JE. Offshore Risk Assessment – Principles, Modeling and Applications of QRA studies. PP393, ISBN 0-7923-5860-0, Kluwer Academic Publishers, 1999.

Wickens CD and Flach JM. Information Processing. In Wiener EL and Nagel DC. (Eds.). Human Factors in Aviation. ISBN 0-12-750030-8, Academic Press, Inc., 1988.

A P P E N D I X

B. INCIDENT ANALYSIS

Nine tanker drive-off events are analyzed and results are provided in this appendix. Relevant information of this incident study is given in Chapter 3 (Section 3.2) in the main report.

B.1 COLLISION INCIDENT A

Initiation of PFM: P (PFM)						
Weather	Relative Motion (FPSO & ST)	PRS & Sensors (FPSO & ST)	Thruster Main Propeller (FPSO & ST)	Tanker DP System	Tanker DP Operator	
<ul style="list-style-type: none"> - FSU was totally passive, surging and fishtailing excessive. - Hawser tension increase due to surging, which triggered DP to “believe” ST is behind the target position, and subsequently DP drove tanker forward. 						
Recovery action: P (action PFM)			Outcome: P (collision action & PFM)			
No action	Action worsen situation	Action mitigate situation		Collision		Near miss
		Too late	In time	Time since drive-off	Speed at contact	
<ul style="list-style-type: none"> - ST pitch shift system needed from full ahead to full astern 1 minute, too long. - Emergency stop of ST succeeded, no contact, but FSU then surged back and collision happened. - ST operator was not able to decide to rotate ship to either port or starboard due to FSU fishtailing. 				<ul style="list-style-type: none"> - No information of contact time since drive off. - No information of speed at contact. 		

B.2 COLLISION INCIDENT B

Initiation of PFM: P (PFM)						
Weather	Relative Motion (FPSO & ST)	PRS & Sensors (FPSO & ST)	Thruster Main Propeller (FPSO & ST)	Tanker DP System	Tanker DP Operator	
<ul style="list-style-type: none"> - More than 30° heading difference developed between tanker and FPSO under light wind and strong spring tides condition. - Operator selected Manual DP with surge and yaw controlled. He used joystick to steer tanker in sway to align it with FPSO. - DP responded by put ahead pitch to get enough turning moment from rudder (sideway thruster capacity is not enough), this drove tanker ahead. 						
Recovery action: P (action PFM)			Outcome: P (collision action & PFM)			
No action	Action worsen situation	Action mitigate situation		Collision		Near miss
		Too late	In time	Time since drive-off	Speed at contact	
<ul style="list-style-type: none"> - No distance alarm warning in Manual DP. - Hard to see Artemis screen when standing at DP console. 			<ul style="list-style-type: none"> - 120 seconds since drive off. - No information of speed. 			

B.3 COLLISION INCIDENT C

Initiation of PFM: P (PFM)						
Weather	Relative Motion (FPSO & ST)	PRS & Sensors (FPSO & ST)	Thruster Main Propeller (FPSO & ST)	Tanker DP System	Tanker DP Operator	
<ul style="list-style-type: none"> - DARPS failure on ST (Gyro unit failure on FPSO) - DP operator re-select DARPS into DP, DP accept wrong position data and calculated wrong distance. - DP then drove tanker full ahead. 						
Recovery action: P (action PFM)				Outcome: P (collision action & PFM)		
No action	Action worsen situation	Action mitigate situation		Collision		Near miss
		Too late	In time	Time since drive-off	Speed at contact	
<ul style="list-style-type: none"> - DP operator selected DP auto heading and used joystick full astern, approx. 1.5 min later after position warning. 				<ul style="list-style-type: none"> - 203 seconds since drive off - 0.16 knots contact speed, max speed 1.6 knots after approx. 60 s. 		

B.4 COLLISION INCIDENT D

Initiation of PFM: P (PFM)						
Weather	Relative Motion (FPSO & ST)	PRS & Sensors (FPSO & ST)	Thruster Main Propeller (FPSO & ST)	Tanker DP System	Tanker DP Operator	
<ul style="list-style-type: none"> - Weather deteriorating, FPSO gradually changed heading. Due to failure of one thruster (one of the two), FPSO had significant fishtailing motion. - Tanker changed heading to follow FPSO, however due to limited thruster power and different weathervaning capability, it had difficulties positioning itself relative to FPSO. Therefore tanker DP operator took manual control by using DP Manual Bias function to position tanker heading, this action prioritized heading over distance control. - DP responded by put 40 % forward pitch to get a turning moment from rudder, this drove tanker ahead. 						
Recovery action: P (action PFM)				Outcome: P (collision action & PFM)		
No action	Action worsen situation	Action mitigate situation		Collision		Near miss
		Too late	In time	Time since drive-off	Speed at contact	
<ul style="list-style-type: none"> - DP operator took “manual bias” to initiate astern pitch, 167 s after drive-off was occurred. - Captain’s use of “manual bias” to intervene was not effective. 				<ul style="list-style-type: none"> - No info. of collision time - Speed at contact approx. 0.7 knots 		

B.5 COLLISION INCIDENT G

Initiation of PFM: P (PFM)						
Weather	Relative Motion (FPSO & ST)	PRS & Sensors (FPSO & ST)	Thruster Main Propeller (FPSO & ST)	Tanker DP System	Tanker DP Operator	
<ul style="list-style-type: none"> - More than 20° heading deviation between FPSO & ST - DP operator changed from “Weathervane” to “Auto Position”, to align tanker with FPSO. - DP software bug resulted in a false DP current, and DP started to put forward thruster to balance this “current”. This drove tanker ahead. 						
Recovery action: P (action PFM)				Outcome: P (collision action & PFM)		
No action	Action worsen situation	Action mitigate situation		Collision		Near miss
		Too late	In time	Time since drive-off	Speed at contact	
<ul style="list-style-type: none"> - DP operators selected “Manual DP” and used “high gain” joystick for a full astern maneuvering of tanker, 58 s after drive-off initiation. 				<ul style="list-style-type: none"> - 125 seconds since drive off - Contact speed is 1.2 knots 		

B.6 NEAR MISS E

Initiation of PFM: P (PFM)						
Weather	Relative Motion (FPSO & ST)	PRS & Sensors (FPSO & ST)	Thruster Main Propeller (FPSO & ST)	Tanker DP System	Tanker DP Operator	
<ul style="list-style-type: none"> - DP registered a not present stream about 5 knots - DP commanded the engines and main propellers to provide forward thrust to compensate the “fictitious” stream. This drove ST forward. 						
Recovery action: P (action PFM)				Outcome: P (collision action & PFM)		
No action	Action worsen situation	Action mitigate situation		Collision		Near miss
		Too late	In time	Time since drive-off	Speed at contact	
<ul style="list-style-type: none"> - Action was taken when vessel had a forward speed of 0.8 knots. - Switched to manual and 60 % astern is used. 				<ul style="list-style-type: none"> - Vessel stopped 1 m inside the short distance alarm limit, about 40 m from the ST front edge to FPSO stern. 		

B.7 NEAR MISS F

Initiation of PFM: P (PFM)						
Weather	Relative Motion (FPSO & ST)	PRS & Sensors (FPSO & ST)	Thruster Main Propeller (FPSO & ST)	Tanker DP System	Tanker DP Operator	
<ul style="list-style-type: none"> - Error in pitch servo pump caused main propeller failure. - DP operator re-selected the main propeller (which had been restarted) into DP. - DP then demanded 100 % pitch forward from the main propeller. This drove tanker ahead. 						
Recovery action: P (action PFM)				Outcome: P (collision action & PFM)		
No action	Action worsen situation	Action mitigate situation		Collision		Near miss
		Too late	In time	Time since drive-off	Speed at contact	
<ul style="list-style-type: none"> - Action initiated around 45 s¹ after drive-off. Switched to manual on engine control panel, handle full astern on main propeller, no response, bow thrusters full to starboard. - Emergency full astern on, no response. - Switched off 0-pitch system. - Pitch main propeller responded to full astern. 				<ul style="list-style-type: none"> - Tanker stopped 120 m astern of FPSO, 45 deg misalignment. - Stopped at about 140 s² after drive-off 		

¹ The estimate comes from DP alarm prints combined with the event description in the investigation report. The drive-off was initiated after reselection of failed thruster No.4 at around 17:52:40. At 17:53:21, i.e. 41 seconds later, there was an alarm indicating high thruster force. Operator took action seconds after this alarm, and this gives the 45 s evidence.

² FPSO control was informed that the tanker had a problem but that it had been solved, at 17:55:00. Tanker started to pull back at this time. These facts indicate the 140 s stoppage.

B.8 NEAR MISS H

Initiation of PFM: P (PFM)						
Weather	Relative Motion (FPSO & ST)	PRS & Sensors (FPSO & ST)	Thruster Main Propeller (FPSO & ST)	Tanker DP System	Tanker DP Operator	
- During tanker "approach" at 85 m with messenger line onboard, DP drove ship ahead which exceeded 15 m and registered speed 1.2 knots.						
Recovery action: P (action PFM)			Outcome: P (collision action & PFM)			
No action	Action worsen situation	Action mitigate situation		Collision		Near miss
		Too late	In time	Time since drive-off	Speed at contact	
- Machinery full astern			- Ship stopped at 45 m			

B.9 NEAR MISS I

Initiation of PFM: P (PFM)						
Weather	Relative Motion (FPSO & ST)	PRS & Sensors (FPSO & ST)	Thruster Main Propeller (FPSO & ST)	Tanker DP System	Tanker DP Operator	
<ul style="list-style-type: none"> - DARPS unit heading signal interference¹. - FSU heading function was deselected by the DP. DP operator reselected the heading signal into DP, during which a possible interference occurred again². - DP accepted erratic FSU heading data, calculated wrong relative position between FSU and drove tanker ahead. 						
Recovery action: P (action PFM)				Outcome: P (collision action & PFM)		
No action	Action worsen situation	Action mitigate situation		Collision		Near miss
		Too late	In time	Time since drive-off	Speed at contact	
<ul style="list-style-type: none"> - There is no operator action time information recorded in the investigation report. - Based on interview with the individual who has indirect information, operator reacted very quickly. 				<ul style="list-style-type: none"> - Tanker drove off 14.5 m forward. - Tanker stopped at around 75 s after drive-off. Tanker then moved backwards. 		

¹ Currently there are only 4 frequencies available for use with all 44 DARPS units installed throughout the North Sea area. With relative short distance between some of the installations, interference between DARPS units may happen. This interference problem may be solved by designing equipment that is free of co-channel interference. It is current under development by Kongsberg Seatex.

² Note that there was a repeated de-selection and re-selection process between DP and DP operator, due to that DARPS interference continually happened, prior to drive-off.

C. SIMULATION MODEL CALIBRATION

The objective is to calibrate the simulation models of FPSO and tanker so that the simulated horizontal motions of these two vessels in SIMO can agree reasonably with the physical phenomena. The approach starts from validating every group of vessel input information in SIMO based on model test data, design information, and other empirical data if relevant. Afterwards, given the similar environmental conditions, positioning system (DP and mooring) and vessel (linear, quadratic) damping in surge, sway and yaw are tuned, and motions of the joint FPSO-tanker system are simulated and compared to the full-scale measurements. The comparison criteria are statistical values of surge, sway and yaw motions. After tuning the simulation models, reasonable matches between simulation and measurement should be observed. The model calibration work is detailed in Section C.1. Background and pre-processing of the full-scale motion measurements of FPSO-tanker during tandem offloading in the North Sea in winter 2001-2002 are provided in Section C.2. In addition, the basics of time-domain motion simulation theory used in SIMO are briefly outlined in Section C.3.

C.1 FPSO AND TANKER MODEL CALIBRATION

The simulation model calibration work starts from a passive FPSO model as described in Section C.1.1. Relevant model test results and empirical data are used. Then a DP FPSO model is calibrated in Section C.1.2 based on full-scale measurements. Calibrations of the tanker model and the joint FPSO-tanker model take into account of qualitative operational information and quantitative full-scale measurement. These are presented in Section C.1.3 and Section C.1.4.

Note that the precise match between simulation and full-scale measurement is close to a mission-impossible task. We have to be aware of the idealizations contained in the simulation program itself. In addition, significant amount of information is not available or not possible to obtain in the full-scale measurement, e.g. vessel loading condition, current information, onboard usage of thrusters, to list a few. Accordingly, idealizations and assumptions are introduced into the simulation to account for these unknowns. However, it is still considered possible to judge the reasonability of the simulation model via comparing statistical values of motions and behavior of motion trace plots to the measurements. After all, the simulation model is to be used for the surging and

yawing study in Chapter 4, which is a different application from traditional applications of time-domain motion simulation, e.g. mooring and riser system analyses and, thruster consumption studies, in the sense that the interested parameters are relative distance and relative heading between the two vessels.

C.1.1 Passive FPSO model calibration

The FPSO turret mooring system model in SIMO is setup based on the design information from the model test report (Marintek, 1994). This gives out a reasonable natural period in surge compared to the full-scale measurement (Andersen, 2000).

The passive FPSO surge damping is considered mainly from linear damping provided by turret mooring system. 15 % of critical surge damping is estimated which is roughly 1500 kN/(m/s). The passive FPSO yaw damping is considered mainly from quadratic damping provided by vessel hull. Based on the quadratic current coefficient, a simple estimation of quadratic yaw damping is made, and it is calculated as $8.57E+08$ kNm/(rad/s)².

Based on the environmental conditions in Chapter 4 (Section 4.5), the simulated 3-hour FPSO stern motion trace at hawser connection point is plotted with a 20-minute full-scale measurement in Figure C - 1. Due to normalization according to the mean stern point in the plot, the mean position is not reflected in the figure. Statistical values of motion are presented in Table C - 1. Clearly we observe relatively larger surge and yaw motions. This is because thrusters were used onboard to reduce the motion amplitudes when measurements were taken, i.e. the 20-minute full-scale measurements were actually from a DP FPSO.

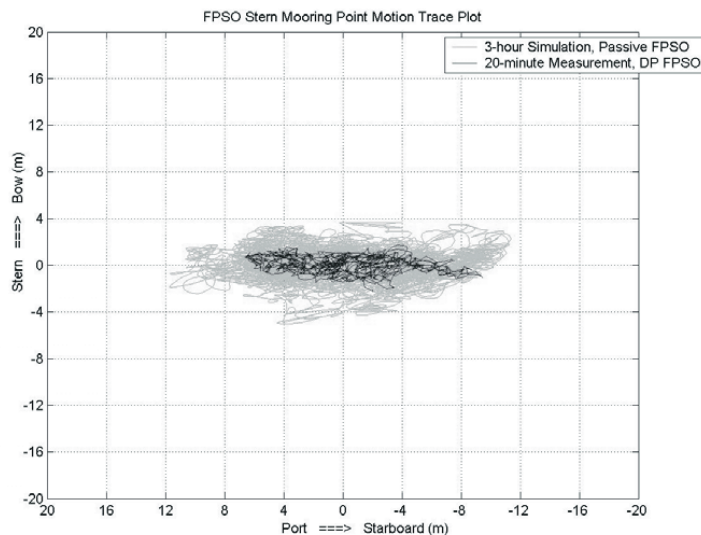

Figure C - 1 Passive FPSO motion in 3-hour simulation

From the model test information which extrapolated to the full-scale (Marintek, 1999), a passive FPSO under a similar offloading environmental ($H_s = 4.5$ m) condition has a yaw motion standard deviation of 2.39. In our simulation, the standard deviation of yaw motion is 2.24. This may roughly confirm that the yaw motion simulated in the passive FPSO model is reasonable. However, there is no other information available for further validation of the yaw motion, nor the surge motion.

	Mean	Std.	Max.	Min.
Surge (m)	-3.40	1.36	3.68	-5.03
Yaw (∇)	-1.81	2.24	5.34	-6.32

Table C - 1 Passive FPSO motion statistics in 3-hour simulation

C.1.2 DP FPSO model calibration

A brief description of full-scale measurement is given here. The 20-minute FPSO surge and yaw motions are measured. The environmental conditions at the same time are also measured which have been described in Chapter 4 (Section 4.5). The motion statistical values and natural periods are presented in Table C - 2.

	Mean	Std.	Max.	Min.	T_n (s)
Surge (m)	-3.31	0.68	1.77	-2.25	171
Yaw (∇)	0.03	1.45	3.70	-2.72	600

Table C - 2 FPSO motion statistics in 20-minute measurements

The stiffness, damping and integral terms in the FPSO PID controller in SIMO are tuned, and finally the simulated FPSO surge and yaw motions give out reasonable statistics that are close to the measurements. The 20-minute is a relatively short duration for low frequency motions. Longer duration measurements are not available for the used environmental conditions. To account for statistical variations, 10 simulations with 20-minute duration are carried out, and we can observe a convergent match of motion standard deviation between simulations and measurement as presented in Figure C - 2.

In summary, the FPSO model is tuned and considered reasonable for the study purpose. The simulated 3-hour FPSO stern motions are shown in Figure C - 3. Statistical values of motions are presented in Table C - 3.

	Mean	Std.	Max.	Min.
Surge (m)	-3.57	0.83	2.32	-4.53
Yaw (∇)	0.09	1.35	3.66	-5.19

Table C - 3 DP FPSO motion statistics in 3-hour simulation

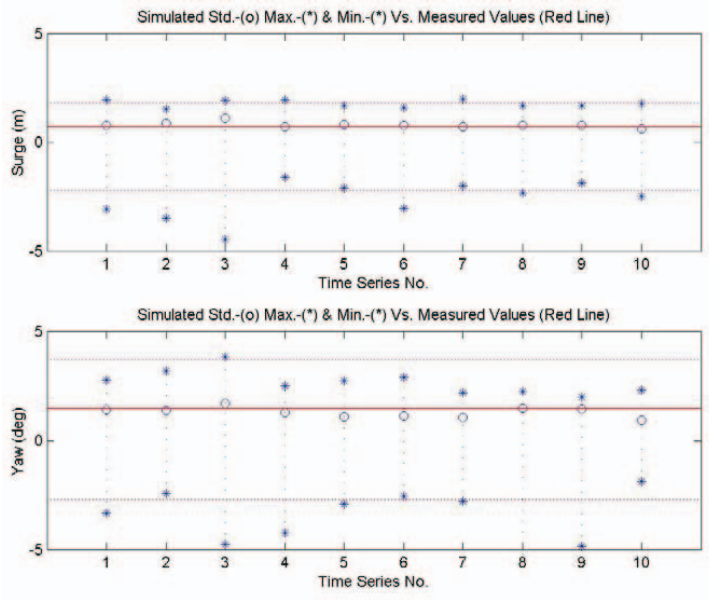

Figure C - 2 20-minute motion statistics from simulations and measurement

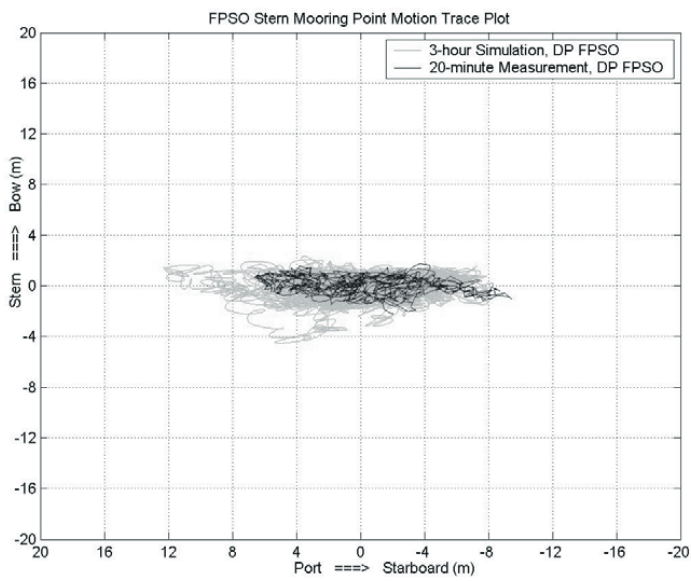

Figure C - 3 DP FPSO motion in 3-hour simulation

C.1.3 FPSO-Tanker model calibration

In the earlier attempt, the environmental conditions as described in Chapter 4 (Section 4.5) are used. Ideally, the FPSO-tanker model calibration should be based on the full-scale FPSO and tanker motion measurements taken in the mean time. However, tanker data are not available. We therefore have to rely on qualitative operational information of tanker bow movement and heading behavior in tandem offloading (Gudmestad, 2002).

Tanker bow is generally moving fore and aft well within -15/+5 m. And tanker heading variation is well within +/- 15 deg relative to FPSO's heading. Beyond these limits there are alarms from DP. If the operation goes on normally, these alarms should not be triggered frequently. We may therefore qualitatively estimate that tanker motion should be within these alarm limits in normal operation.

In the simulation model, tanker quadratic yaw damping is similarly estimated based on the current coefficient, as $9.79E+08 \text{ kNm}/(\text{rad/s})^2$. Stiffness, damping and integral terms in tanker PID controller are tuned, and simulated surge and yaw motions for base case configurations as described in Chapter 4 (Section 4.6) are presented in Figure C - 4. Statistical values of motion are presented in Table C - 4. These preliminary results are considered reasonable based on the fore-mentioned qualitative criteria of tanker motion.

Surge (m)	Mean	Std.	Max.	Min.
FPSO	-3.48	0.76	-1.40	-6.48
TANKER	-3.45	1.24	-0.83	-9.53
Yaw (°)	Mean	Std.	Max.	Min.
FPSO	0.03	1.27	3.42	-3.67
TANKER	-0.02	1.15	3.40	-3.49

Table C - 4 FPSO-Tanker motion statistics in 3-hour simulation

After full-scale FPSO and tanker motion data in tandem offloading and the corresponding environmental conditions were received in the spring of 2002 (these data are presented in Section C.2), the joint FPSO-tanker model was further calibrated based on the quantitative criteria from the measurements. The following is a calibration example based on the 2-hour motion measurements taken on 30 January 2002, which is described as Case A in Section C.2 in the following.

The base case FPSO and tanker configurations as described in Chapter 4 are assumed. Similar environmental conditions are imposed in the simulation as in the 2-hour measurements. The simulation results and measurements are compared via the statistical values of surge and yaw motions presented in Table C - 5, as well as the FPSO stern and tanker bow motion trace plot presented in Figure C - 5. Reasonable matches are observed between simulation results and measurements. For completeness, simulated time series of surge and yaw motions for both vessels are presented in Figure C - 6.

In summary, the conclusion after the above calibration work is that the present FPSO-Tanker model is able to reasonably simulate the physical horizontal motions between FPSO and tanker in tandem offloading.

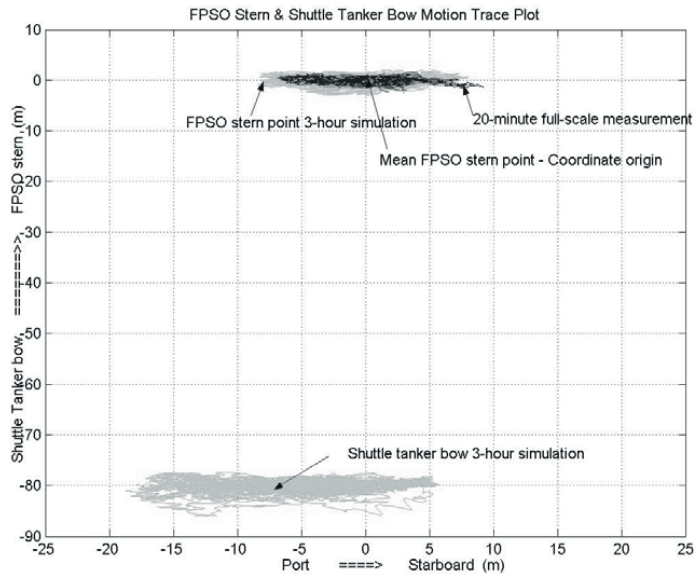

Figure C - 4 FPSO-Tanker motion in 3-hour simulation

FPSO Surge (m)	Mean	Std.	Max.	Min.
Measurement	NA	1.06	3.68	-5.72
Simulation	-2.13	1.67	4.77	-5.63
FPSO Yaw (°)	Mean	Std.	Max.	Min.
Measurement	0.00	0.59	1.90	-1.50
Simulation	0.07	0.76	2.55	-2.26
Tanker Surge (m)	Mean	Std.	Max.	Min.
Measurement	NA	1.50	3.85	-7.91
Simulation	-2.51	1.37	4.46	-5.59
Tanker Yaw (°)	Mean	Std.	Max.	Min.
Measurement	6.00	1.77	11.70	3.20
Simulation	4.70	1.26	8.13	1.65

Table C - 5 FPSO-Tanker 2-hour motion statistics (Simulation vs. Measurement)

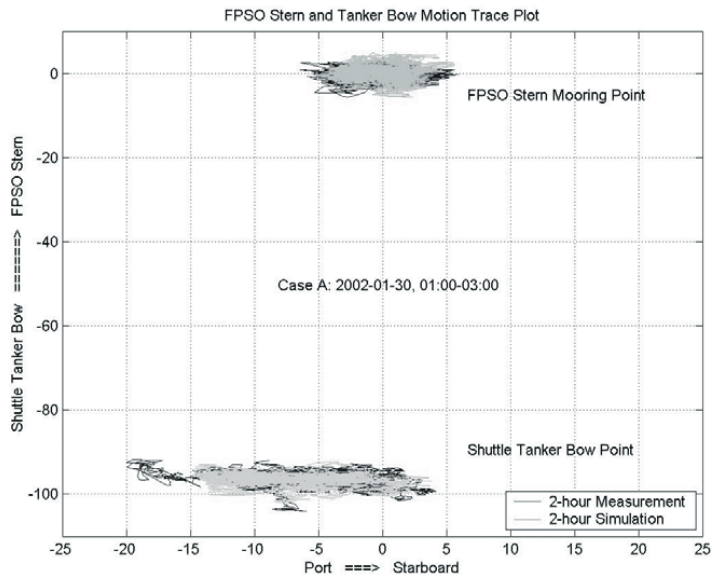

Figure C - 5 FPSO-Tanker 2-hour motion (Simulation vs. Measurement)

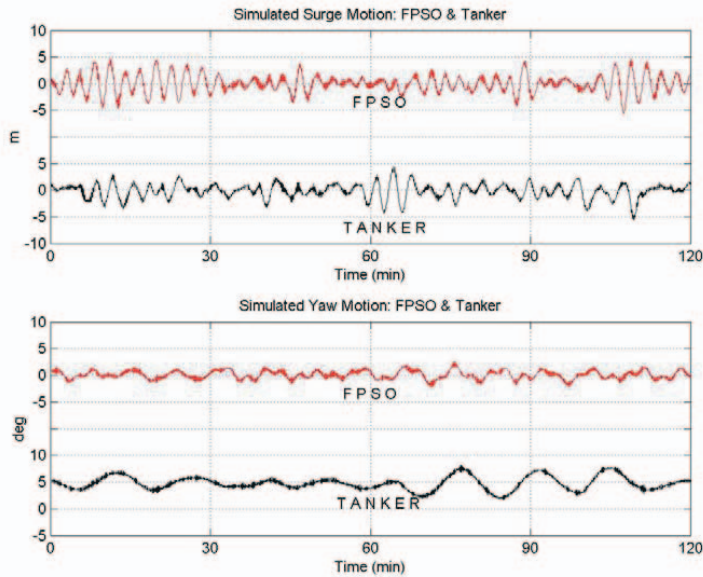

Figure C - 6 Simulated time series of surge and yaw motions

C.2 FULL-SCALE FPSO-TANKER MOTION MEASUREMENTS

C.2.1 Raw data

FPSO and tanker motion measurement data are partly provided by BLOM A/S (Blom, 2002a). The data are obtained from a North Sea DP2 shuttle tanker during loading from an FPSO in winter 2001-2002. There are in total 9 episodes as listed in Table C - 6. Each of them lasts for three hours. The sampling frequency is the best that BLOM PMS can provide, and it varies roughly between 1.00 – 0.25 Hz.

Episode	Date	Time
1	2001-11-21	15 – 18
2	2001-11-21	18 – 21
3	2001-12-26	12 – 15
4	2001-12-27	00 – 03
5	2002-01-22	12 – 15
6	2002-01-24	05 – 08
7	2002-01-30	00 – 03
8	2002-02-01	15 – 18
9	2002-02-09	01 – 04

Table C - 6 Time and date for all episodes

Each measured episode consists of the following data:

- Time GMT (Greenwich Mean Time)
- Heading of tanker
- Heading of FPSO
- Difference in heading between tanker and FPSO
- Distance from tanker bow to FPSO stern (reference point)
- Bearing from tanker bow to FPSO stern (reference point)
- Tanker bow Northing earth coordinate
- Tanker bow Easting earth coordinate

The instantaneous Northing and Easting coordinates of FPSO stern reference point (Artemis station in this case) can be derived based on *Distance*, *Bearing* and *Tanker bow* position in BLOM data. The Artemis station is located at: longitudinally –160.93 m from turret center, 0.98 m from middle to the port side.

The FPSO heading values in the BLOM data are however, do not reflect the instantaneous yaw motion of the FPSO. It looks as if the FPSO has a constant heading plus many sudden jumps in 3-hour duration. This is not physically true. The constant/jumping behavior is probably due to the fact that FPSO heading values were taken from the DARPS unit on tanker, and only some kind of averaged FPSO heading values were recorded. Therefore FPSO heading together with the heading difference values in the BLOM data are excluded. The instantaneous FPSO heading data are obtained from STATOIL (Andersen, 2002).

The environmental data in each of the above measurement are provided by STATOIL (Haver, 2002). The data consist of 20-minute (or in some episodes 40-minute) mean values of the following items:

- Mean wind speed
- Mean wind direction
- Significant wave height
- Spectral peak period
- Mean wave direction (exclude measurement No.1, 2, 3 and 4)

C.2.2 Selection of time series

There are 7 time series that are selected from these 9 episodes as qualified for use in the calibration of the joint FPSO-tanker model in SIMO. They are listed in Table C - 7. Note there are basically three types of cases marked with A, B, and C, corresponding to H_s between 4-5 m, 3-4 m, and 2-3 m, respectively. To further elaborate FPSO and tanker motion behavior in class A and B, sensitivity cases with shorter duration are identified.

Case No.	Date & Time	Duration	H_s (mean)	U_w (mean)
A	2002-01-30, 01:00 – 03:00	120 min	4.9 m	9.8 m/s
A1	2002-02-09, 01:40 – 02:40	60 min	4.5 m	9.5 m/s
A2	2001-12-26, 13:30 – 14:30	60 min	4.2 m	6.4 m/s
B	2002-01-24, 05:20 – 08:00	160 min	3.8 m	6.6 m/s
B1	2002-02-09, 02:40 – 03:40	60 min	3.7 m	7.9 m/s
B2	2002-01-22, 12:00 – 13:00	60 min	3.3 m	10 m/s
C	2002-02-01, 16:40 – 17:40	60 min	2.5 m	17 m/s

Table C - 7 Identified 7 time series qualified for calibration purpose

The criteria for selecting these 7 time series are as follows. First, there should not exist any apparent measurement errors such as sudden incredible number or miss of data. (Note that the instantaneous FPSO heading data in case A2 and B2 are partly lacking, however, these two cases are still considered representative to illustrate tanker motions, and therefore, they are included.) Second, the FPSO and tanker in simulation are keeping their mean heading, i.e. no operated heading change in simulation. Therefore, in measurement, there should not be any dramatic mean heading change on either FPSO or tanker. Third, only stable weather can be simulated, so in measurement, especially the significant wave height H_s and wind speed U_w , there should ideally be as less variation as possible. Fourth, the qualified low frequency motion oscillations should be kept as many as possible so that statistical uncertainty can be minimized. This means we have to keep as long as possible the duration for the qualified episode.

C.2.3 Pre-processing of time series

To facilitate comparison with simulation, a uniform coordinate system is defined as in Figure C - 7 to present the measured FPSO and tanker motion time series. This

coordinate is defined based on FPSO mean heading and mean stern point as stated below. Tanker heading and environmental parameters' directions are accordingly presented clockwise relative to the mean FPSO heading as positive, instead of relative to the North.

- Origin: mean position of FPSO stern point.
- Longitudinal (surge) X: pointing along FPSO mean heading from stern to bow.
- Transverse (sway) Y: pointing perpendicular to X, to FPSO starboard.

Since the original measurements are presented in earth coordinate, i.e. Northing, Easting and heading clockwise relative to the North, measurement data are converted into the above coordinate system. As an example, the converted measurement data in Case A are plotted in Figure C - 8 together with the environmental parameters that are used in the simulation. Wave and wind data are mainly from the measurement, while current data are based on assumption.

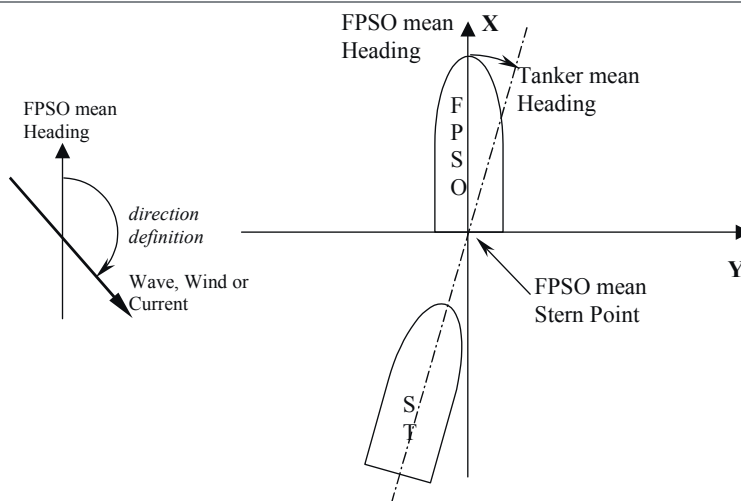

Figure C - 7 Coordinate system used in presenting the measurements

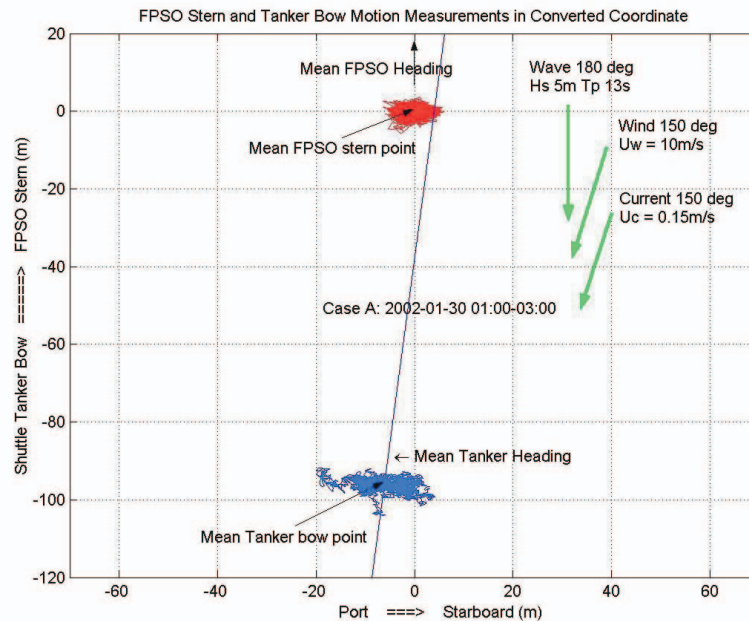

Figure C - 8 Pre-processing of the measurement data (Case A)

C.3 THEORY

C.3.1 Method overview

The equation of motion for one or several bodies in general may be written as:

$$\mathbf{M}\ddot{x} + \mathbf{C}\dot{x} + \mathbf{D}_1\dot{x} + \mathbf{D}_2f(\dot{x}) + \mathbf{K}x = \mathbf{q}(t, x, \dot{x}) \quad (\text{C-1})$$

where x is a position vector, and \mathbf{q} is an exciting force vector. \mathbf{M} is a frequency dependent mass matrix. It has contributions from body mass and frequency dependent added mass. \mathbf{C} is a frequency dependent potential damping matrix. \mathbf{D}_1 and \mathbf{D}_2 are linear and quadratic damping matrices. The f function is a vector function where each element is given by $f_i = \dot{x}_i |\dot{x}_i|$. \mathbf{K} is a position dependent hydrostatic stiffness matrix.

The above motion equation is solved by separating motion in high-frequency (HF) and low-frequency (LF) parts, see Eq.C-2. In this simulation study, the LF motion components are of the main interest since they have the dominant contributions to the surge, sway and yaw motions. The advantage of this approximation instead of solving the whole differential equation in time domain is the save of computational time, since calculation of the convolution integrals are avoided and the time step can be set longer.

$$\begin{aligned} \mathbf{M}\ddot{\mathbf{x}}_{HF} + \mathbf{C} + \mathbf{D}_1 \dot{\mathbf{x}}_{HF} + \mathbf{K} \mathbf{x}_{HF} &= \mathbf{q}^{(1)} \\ \mathbf{M}\ddot{\mathbf{x}}_{LF} + \mathbf{D}_1 \dot{\mathbf{x}}_{LF} + \mathbf{D}_2 \dot{\mathbf{x}}_{LF} + \mathbf{K} \mathbf{x}_{LF} &= \mathbf{q}^{(2)} \end{aligned} \quad (\text{C-2})$$

The solution of the HF part is obtained in frequency domain by means of transfer functions. This implies that for HF solutions \mathbf{D}_2 (quadratic damping) is treated as zero, and \mathbf{K} (stiffness) can be viewed as constant. The HF transfer functions may be computed by a standard hydrodynamic program, e.g. WADAM, and given as input to SIMO. The solution of the LF part is obtained in time domain since forces which are not linear to the wave amplitude are involved. A modified 3rd order Runge-Kutta based method is used for numerical integration. The total motion is obtained by superposition of the two time series.

The motion simulation of 2-body system, i.e. FPSO and tanker, is done by calculating the motions of each body separately, and treating the coupling between the two bodies as excitation forces. This approach also provides the advantage of significant saving of computational time. It is considered valid since the coupling between FPSO and DP shuttle tanker are *weak*, i.e. two vessels are connected by loading hose and a non-load bearing mooring hawser. Bodies connected by articulated joints or hinges are, for example, considered to have a *strong* coupling.

After an overview of how simulation is carried out, I will in the following outline the detailed modeling of each term in *LF* part in Eq.C-2.

C.3.2 Mass, damping, stiffness and excitation forces

The mass term contains body mass matrix and added mass (at zero frequency) matrix. The body mass matrix may be found from design information. The added mass matrix is calculated by WADAM, and is given as input to SIMO.

The damping term includes linear, quadratic and wave drift damping matrices. Linear and quadratic damping values are given as input and tuned in the model calibration process. The wave-drift damping matrix is however not included in the model, since the environmental condition used in simulation of offloading operation in general has the significant wave height smaller than 5.5 m. Wave-drift damping contribution is believed to be small.

The stiffness term includes hydrostatic stiffness, and external stiffness provided by mooring system and DP system. There is no hydrostatic stiffness contribution to the horizontal motions. Mooring and DP stiffness contributions are addressed as “stiffness force” in the section of mooring and DP force models.

Overall, the excitation force vector may have the following components, see Eq.C-3. \mathbf{q}_{wa}^1 is the first order wave excitation force. \mathbf{q}_{wa}^2 is the second order wave excitation force. Higher order wave excitation, i.e. ringing force is not considered. \mathbf{q}_{wi} is the wind force. \mathbf{q}_{cu} is the current force. \mathbf{q}_{ext} is the external excitation force, including

contributions from mooring system, DP (acting via thruster) and coupling forces between two vessels.

$$\begin{aligned} \mathbf{q} &= \mathbf{q}^{(1)} + \mathbf{q}^{(2)} \\ \mathbf{q}^{(1)} &= \mathbf{q}_{wa}^1 \\ \mathbf{q}^{(2)} &= \mathbf{q}_{wa}^2 + \mathbf{q}_{wi}^2 + \mathbf{q}_{cu}^2 + \mathbf{q}_{ext}^2 \end{aligned} \quad (C-3)$$

The HF excitation force, i.e. the first order wave excitation force, \mathbf{q}_{wa}^1 , is obtained in frequency domain by multiplication of linear transfer function $H^{(1)}/\omega$ and wave amplitude ζ/ω in 6 degrees of freedom. The needed transfer functions are given as input for a number of frequencies and directions.

Modeling of the remaining LF excitation forces is discussed in the following sections.

C.3.3 Wave force (LF)

The irregular wave is modeled by a 3-parameter JONSWAP spectrum. It is considered as a wind sea case. Significant wave height, peak period and peakedness factor are specified. The short-crest sea is accounted by modifying wave spectrum with a mean wave propagation direction and a \cos^4 spreading function. Swell, preferably from another direction, is not modeled. This is due to the fact that SIMO cannot evaluate the second order wave excitation force as a sum from both wind sea and swell.

The time series of wave are generated by the FFT (Fast Fourier Transform) method with random phase (Stansberg, 1989). The method involves discretizing the wave spectrum into a large number of finite-valued harmonic components, sampling phases from a uniform distribution over Ψ, ϕ, β , and adding the harmonic components to obtain the time series.

The second order wave excitation force, \mathbf{q}_{wa}^2 , is calculated by multiplication of the drift force coefficients $G/\omega, \zeta$ and square of wave amplitude ζ/ω^2 . The $G/\omega, \zeta$ is defined as the wave drift force in each degree of freedom due to a regular wave component with frequency ω in direction ζ . It is calculated in WADAM, and is given as input. The time series of \mathbf{q}_{wa}^2 is derived in this simulation study by Newman's method (Newman, 1974) which is based on the surface elevation and directionally averaged drift force coefficient (function of frequency). In SIMO, \mathbf{q}_{wa}^2 is calculated before time domain simulation for a number of heading cases, and interpolations between these time series in time domain are made to an instantaneous heading.

C.3.4 Wind force

The wind field is assumed to be 2-dimensional, propagating parallel to the horizontal plane. There is no account for the wind shielding effect between two vessels in simulation. That is, the two vessels experience the same wind speed. The wind velocity is modeled by a mean speed plus a gust, propagating to a mean direction. The gust, i.e. varying part of the wind velocity in the mean direction, is modeled by a NPD spectrum.

The time series of wind velocity is obtained by the same FFT-method with random phase.

The wind force (time series) is calculated by multiplication of wind force coefficient C_{wi}/ζ and instantaneous wind velocity (relative to body) square v^2 for each degree of freedom. The coefficient C_{wi}/ζ is a function of direction ζ , and is given as input for surge, sway, and yaw.

C.3.5 Current force

The current is modeled by a profile with specified direction and speed at different levels. Linear interpolation is used between the levels.

The current viscous force/moment on hull in surge, sway and yaw are calculated by multiplication of the current coefficients C_{ci}/ζ and square of the instantaneous value of the relative velocity between body and current. Note the body has low frequency velocity and this LF velocity is included in the model.

The above model does not account for the effect from the yaw-induced cross-flow. This cross flow is included as a separate quadratic yaw damping estimated from current coefficient.

C.3.6 Station-keeping forces

The external excitation force \mathbf{q}_{ext} includes station-keeping forces and coupling force. The station-keeping forces are discussed here, which has contributions from mooring and DP.

The turret mooring system provides FPSO with stiffness in surge, sway and yaw. The reason that yaw stiffness is provided is based on the fact that in normal operation, FPSO has its turret locked. The rotation of vessel (though in very small magnitudes) will then cause rotation of the turret where restoring moment is provided by twisted mooring lines (and risers). The total stiffness contribution provided by the turret mooring system comes from the sum from each mooring line. Each mooring line is modeled by a catenary equation. The procedure for calculating mooring line configuration is based on a "shooting method" (Lie, 1990). Mooring line dynamic tension is calculated based on the model developed by Larsen and Sandvik (1990). Further details are not included here since in motion simulation the tension of individual mooring line is not of interest.

The dynamic positioning system is modeled as a control module with the input from position measurement and thrust measurement. The control module converts position and velocity errors into a demand for thrust forces to correct the errors. The output is the desired resultant forces and moment from thrusters.

The PID (Proportional + Integral + Derivative) controller module in SIMO is applied in the study. A decoupling approach allows PID control parameters to be specified separately for surge, sway, and yaw. The control law of the PID controller is presented in Eq.C-4.

$$F_{T0} = K_p \kappa(t) + K_v \dot{\kappa}(t) + K_i \int_0^t \kappa(\vartheta) d\vartheta \quad (C-4)$$

F_{T0} is the wanted thrust from thrusters. $\kappa(t)$ is the position error, as $\kappa(t) = x_0 - x(t)$ where x_0 is the desired position and $x(t)$ is filtered position. $\dot{\kappa}(t)$ is velocity error, as $\dot{\kappa}(t) = \dot{x}_0 - \dot{x}(t)$. K_p is the position feedback gain, which can be reasonably interpreted as stiffness coefficient. K_v is the velocity feedback gain, which can be interpreted similarly as damping coefficient. K_i is the integral feedback gain. Due to the influence of the integral term and filters (discussed below), the analogy of K_p and K_v to stiffness and damping should not be “over-stretched”. The controlled system response should be judged based on all three gains.

The frequency response of PID controller gain is described here. The PID gain approaches infinity when (low) frequency approaches zero. This is resulted from the integral term. Without this integral term, the static error will occur which would be $x_{stat} = F_{dis} / K_p$, where F_{dis} is the static component of the external disturbing force. The PID gain approaches infinity towards high frequency too. This makes the system very sensitive to high frequency noise in the position and velocity signals, and the noise will be amplified and put through to the thrusters. For this reason, high frequency components are removed by filtering the signals before they are fed to the controller.

Two types of thrusters are modeled in the study, i.e. tunnel thrusters and azimuth thrusters. The former has a fixed direction, while the latter is rotatable. Each thruster is defined by its coordinates, utilization factor, maximum thrust in bollard condition, efficiency, and direction. The thruster allocation is performed by minimizing a quadratic weight function as described by Reinholdtsen and Falkenberg (2000). If the algorithm orders a greater force than the maximum obtainable, the resulting force is set to equal to the maximum obtainable.

C.3.7 Coupling force

The coupling element is the hawser. The hawser is modeled as a non-load bearing spring in the study. It connects the FPSO stern mooring point and shuttle tanker bow.

The coupling force is modeled by a specified force-elongation relationship. Any relationship can be specified in SIMO. The characteristic of hawser tension in the study is 20 kN, as hawser self-weight. The stiffness modeled is about 0.2 kN/m. Damping is not included.

Further interested readers can find more theoretical details in the SIMO user manual available via MARINTEK (Reinholdtsen and Falkenberg, 2000).

C.4 REFERENCES

- Andersen OJ. FPSO motions in offloading. Report PTT MA MKS, (in Norwegian), Statoil, 2000.
- Andersen OJ. E-mail attached ASCII files with FPSO heading, surge and sway measurement data. 22-05-2002.
- Blom AS. Data Preparation – XXXX FPSO & XXXX Tanker. Doc. 0214022-0200075, Rev.01, 2002.
- Gudmestad K. (Kongsberg Simrad). Private communication regarding shuttle tanker motion in tandem offloading. 2002.
- Haver S. E-mail attached spreadsheet with environmental conditions (wind and wave data) and ship heading measurements corresponding to BLOM data. 02-04-2002.
- Larsen K and Sandvik PC. Efficient methods for the calculation of dynamic mooring line tension. The 1st European Offshore Mechanical Symposium, Trondheim, Norway, 1990.
- Lie H. MIMOSA-2 User's Documentation. MT51 F90-0358, Marintek, 1990.
- Marintek. FPSO motion model test results. Report excerpts received from Statoil, 1994 & 1999.
- Newman JN. Second-order, slowly-varying forces on vessels in irregular waves. International Symposium on the Dynamics of Marine Vehicles and Structures in Waves, University College, London, 1974.
- Stansberg CT. On the use, modeling and analysis of irregular water surface waves. Proceedings of the 8th OMAE Conference, Vol. 2, 1989.
- Reinholdtsen SA and Falkenberg E. SIMO – Theory / User Manual. MT51 F93-0184, Marintek, 2000.

A P P E N D I X

D. TECHNICAL SYSTEM AND OPERATIONAL PROCESS

Shuttle tanker bridge layout and relevant technical systems involved in tandem offloading are described. The objective is to introduce readers to the context (i.e. human-machine system and interface) on shuttle tanker, which have been referred to in the main text. The tandem offloading operational process is also described based on onboard observation. This may supplement the briefly mentioned five tandem offloading operational phases in Chapter 1. In addition, special DP positioning features, namely the tandem loading function in tanker DP software, are described. This may clarify the details of how the tanker positions itself relative to the FPSO as discussed in Chapter 4.

D.1 SHUTTLE TANKER BRIDGE

D.1.1 Bridge layout

The shuttle tanker bridge layout with positions of relevant equipment for tandem offloading is sketched in Figure D - 1.

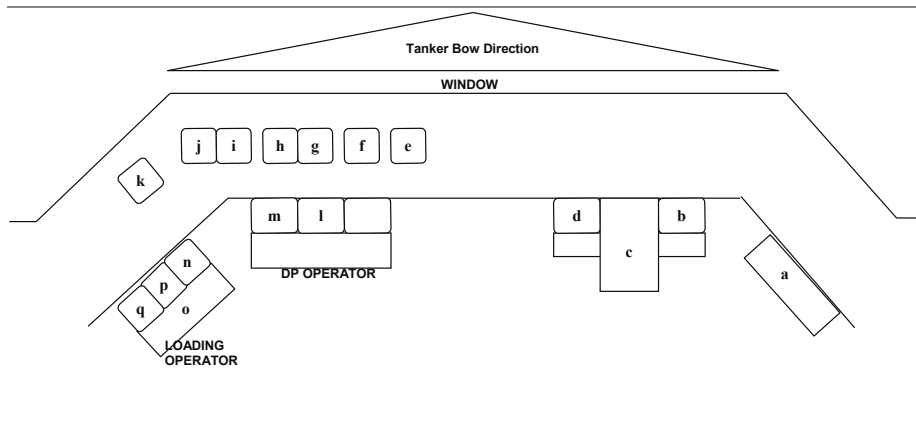

Figure D - 1 Typical shuttle tanker bridge layout

- a. Emergency key (engine & propeller)
- b. Radar
- c. Navigation board
- d. Radar
- e. Artemis screen
- f. Blom PMS monitor
- g. DARPS I screen
- h. DARPS II screen
- i. Video screen of loading hose
- j. Video screen of hawser winch
- k. Video screen of tanker bow and FSU stern
- l. DP II console (Slave)
- m. DP I console (Master)
- n. BLS console
- o. ESD buttons
- p. Loading/ballast console I
- q. Loading/ballast console II

D.1.2 DP console

There are two DP computers installed onboard since this is DP2 class shuttle tanker. In operation, one computer (left one in below figure) is selected as 'Master' and it does the actual positioning job. The other (right one in below figure) is selected as 'Slave', and it works as backup.



Figure D - 2 DP console

D.1.3 Position reference system

The position reference system screens are hung above the DP console. It contains two DARPS screens, one BLOM PMS screen and one Artemis screen from left to right (Figure D - 3). The two DARPS(s) and Artemis form the three position reference units used in the tandem offloading operation.



Figure D - 3 DARPS screen BLOM PMS monitor Artemis screen

The human-machine interface for the location of these position reference screens relative to DP console and manual steering gear is not well tuned. Figure D - 4 (left) illustrates the operator fatigue caused by this. In an emergency drive-off situation, if manual maneuvering of tanker is carried out on the steering board, it is hard to observe the position data due to the location of these screens. This is also recorded in Figure D - 4 (right).



Figure D - 4 Location of PRS screens – in relation to operator and manual steering gear

D.1.4 Bow loading system console

The Bow Loading System (BLS) console is located beside the DP console on the Bridge. ESD buttons can also be found there (shown in Figure D - 5). The operation of ESD I II is to press the first and second (from left) buttons, the third button is to start deluge in bow loading area. The established green line is shown on the screen of bow loading console, as indicated below. Note that the picture located in upper right was taken during actually offloading.



Figure D - 5 BLS console with ESD buttons and green line

D.1.5 Video screen of bow loading area

Three video cameras are installed in the tanker bow area. Visual information is shown on Bridge regarding: i.) the distance information between FSU and ST, ii.) hawser, winch information, and iii.) loading hose connection information. Note that the right pictures were taken during actual offloading.



Figure D - 6 Video screens of bow loading area

D.2 TANDEM OFFLOADING OPERATION

A closer look of FPSO and DP shuttle tanker in tandem offloading is provided in Figure D - 7.

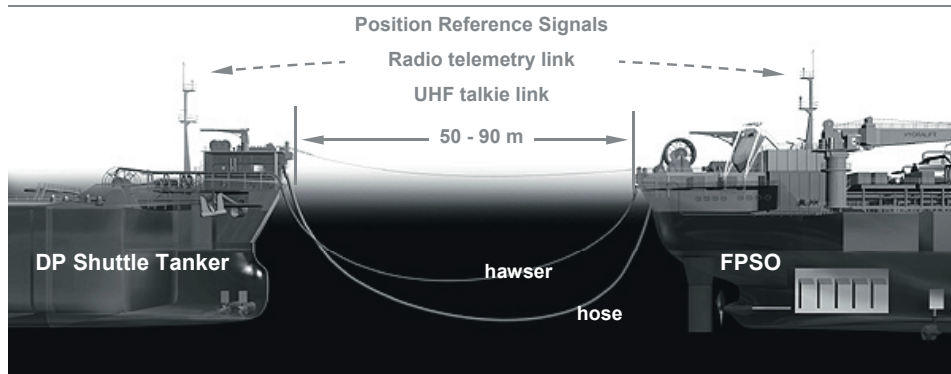

Figure D - 7 FPSO and DP shuttle tanker¹ in tandem offloading

The process for a tandem offloading operation in the North Sea is recorded in Table D - 1 below (Chen, 2001). This table hopefully gives out a series of pictures which clarify how tandem offloading is carried out. In practice, each FPSO/FSU field may require its own operational procedures. However, there are generic elements in the operation. This anonymous case described below serves as a generic example.

Tanker arrived at the 10 NM zone at FSU field at around 4:00 pm. This could in theory be considered as the start of the offloading operation. Tanker asked permission and entered 10 NM zone. However, the approach to FSU was agreed at 3:30 am next day. The following observations therefore start from 3:30 am.

Time / Distance	Operational activities	Phase
3:30 am / 3 NM	Due to dense fog, approach is postponed.	
5:30 am / 4800 m	ST starts to approach FSU. FSU heading 175° ST heading 272° speed 15 kn. Wind 18 kn, 280° wave Hs 1.2 m.	Approach phase starts
2400 m	ST speed 12 kn. Contact from FSU to ST.	Duration: 1 h 20 min
1900 m	ST speed 10 kn.	
5:53 am / 1870 m	Start DP manual ST speed 8.35 kn.	
1718 m	ST speed 3.2 kn.	

¹ Picture adapted from Offshore Technology website, Bow Loading System by Hitec Marine. http://www.offshore-technology.com/contractors/floating_production/hitec_marine/hitec_marine2.html

Time / Distance	Operational activities	Phase
1500 m	ST speed 2.4 kn, heading 170∇	Approach phase continues
1000 m	ST speed 2.5 kn, heading 166∇	
6:18 am / 500 m	ST speed 1.36 kn, heading 168∇ Contact from FSU to ST.	
350 m	ST speed 0.56 kn, heading 172∇	
294 m	ST speed 0.39 kn, heading 176∇	
233 m	ST speed 0.34 kn, heading 172∇	
200 m	ST asking FSU to change heading to 180∇	
6:33 am / 165 m	Start DP Approach mode.	
6:43 am / 118 m	DP drop-out test.	
6:50 am / 75 m	Distance alarm setting, 3 m warning, 5 m alarm.	
75 m	ST contacts FSU. Ready for shooting the messenger line.	
7:00 am / 75 m	FSU shoots the messenger line on ST.	
7:15 am / 75 m	Mooring connection, messenger line rolling.	
7:20 am / 75 m	Chain stopper is locked.	
7:21 am / 75 m	Start DP Weather vane mode. Take into hawser tension into DP reference input.	
7:30 am / 75 m	DP Weather vane mode with 'Operator selected heading'. FSU heading 182∇ ST heading 193∇ This is to facilitate hose connection operation.	
7:35 am	Hose connection is completed. ST asks FSU to change heading to 195∇	
7:45 am	Pump test, shut down test. FSU has problems on its pump initially, and then the problems are fixed.	
8:05 am	ST gets no signal of receiving oil. New pump test is initiated. Chief Officer takes over 1 st Officer on Bridge.	

Time / Distance	Operational activities	Phase
8:36 am	ST starts loading FSU 194∇ ST 198∇ <u>Environmental condition:</u> Hs 1.1 m, Current 2.5 m/s, Wind 9 kn.	Loading phase starts Duration: 11 h 24 min
9:00 am	2 nd DARPS back to normal <u>The position reference used:</u> Artemis – position origin 1 st & 2 nd DARPS – relative distance	
9:10 am	ST in loading FSU 194∇ ST 204∇	
9:25 am	Captain left Bridge. Chief Officer on DP watch. 2 nd Officer on loading operation.	
12:45 pm	FSU 239∇ ST 243∇	
3:30 pm	FSU 314∇ ST 315∇	
4:00 pm	Dense fog, not able to see FSU stern. Wind 16 kn. Loading remains.	
6:00 pm	FSU 1∇ ST 5∇	
7:00 pm	Loading is stopped Start to flush hose from FSU.	
7:50 pm / 75 m	Finish flushing hose. Close coupler valve. Close crude valve.	
8:00 pm	Hose is dropped. Send back hose messenger line.	
8:11 pm	Chain stopper is opened. Send back hawser, chain and messenger line.	Duration: 21 min
8:14 pm	Start DP Approach mode. 100 m set as set point distance.	Departure phase starts
97.6 m	FSU 11∇ ST 35∇	
200 m	Start DP manual.	Duration: 11 min
8:25 pm	All messenger line is sent back. ST sails away.	

Table D - 1 Tandem offloading operational process

D.3 SPECIAL DP FEATURES

The “tandem loading functions” in the tanker DP system have two basic functions (Hals, 2000):

- “FSU SURGE/SWAY” function
- “FSU SWAY/HEADING function

The first one is to make tanker not follow all FSU movements. The second one is to ratify large heading differences between tanker and FSU.

D.3.1 FSU Surge/Sway function

The FSU Surge/Sway function enables the shuttle tanker to automatically follow a moving FSU and keeps the shuttle tanker at a “constant” position relative to the FSU hawser terminal point. This significantly reduce thruster utilization on the shuttle tanker. Like the ordinary Weather Vane mode, the heading of the shuttle tanker is always kept pointing towards the stern of the FSU.

The background of this function is explained as follows. The shuttle tanker has the stern of the FSU (hawser terminal point) as base point. In ordinary Weather Vane and Approach modes, the tanker will “believe” that the stern of the FSU is an earth fixed point, like in SPM loading. However, the FSU stern will move due to surge and fishtail movement. This implies that the DP will estimate any FSU movement as movement of the shuttle tanker. This will lead to wrong current estimates and potentially unstable DP positioning.

The features of this function are described below.

1. A rectangle window is defined within which the FSU stern position can move without causing the shuttle tanker to also move. When the FSU moves outside the border of the rectangle, the rectangle is moved to the actual FSU position and the shuttle tanker setpoint is updated accordingly. The shuttle tanker then moves to the new position.
2. The size of rectangle could be defined by the operator. However, the upper limits are pre-fixed in the DP system. It is important to keep the bow of the shuttle tanker pointing towards the FSU hawser terminal point if the FSU moves due to weathervaning. The sway window must then be small, typically 4-8 m. The surge window is adjusted so that normal surging of FSU does not pass the limit, typically 8-15 m.
3. The shuttle tanker uses earth fixed reference systems (DGPS) for its DP model, while relative position reference systems (Artemis and DARPS) are used for monitoring the FSU movement relative to the shuttle tanker. This ‘relative position information’ is used to update shuttle tanker to the wanted position. Thus, relative and absolute systems are used together for overall position keeping.

D.3.2 FSU Sway/Heading function

This function is developed in order to ratify large heading differences between tanker and FSU. It is implemented as a sway position control where the shuttle tanker heading is kept pointing on the hawser terminal point of the FSU.

The background of this function is explained as follows. The rapid heading change of the FSU is a problem in tandem loading. This problem is more noticeable if the FSU has no heading control. Heading changes of 90° in approximately 30 minutes have been reported during calm weather at the change of tidal stream. Fishtailing movement of 5°-10° at a period of 15 minutes is also commonly experienced. Further, when the draught of the two vessels is very different, i.e. one is full and the other is empty, the optimum (Weather Vane) headings on FSU and tanker can be significantly different, and this imposes significant operational difficulties.

The features of this function are described below.

1. The heading of FSU is transferred over the data-link of the DARPS system to the shuttle tanker. When the operator defined heading difference is exceeded, the tanker thrusters are activated in order to align itself with the FSU. The resulting force is mainly in sway direction, but the heading is continuously adjusted to keep the bow of the tanker pointing towards the FSU stern hawser terminal point.
2. Operator can turn this function ON/OFF, and also define the limits for activating and stopping the sway/heading control.

D.4 REFERENCES

Chen H. FSU-Tanker Offloading Operation: Information from offshore Trip. Restricted internal memo 03-07-01, Revision 24-07-01, Dept. of Marine Structures, NTNU, 2001.

Hals T. Customer acceptance test procedure - Tandem Loading. Kongsberg Simrad, 2000. [restricted]

A P P E N D I X

E. QUESTIONNAIRE SURVEY

SAFETY SURVEY OF TANDEM LOADING OPERATION

Deadline: 18th April 2002

PLEASE RETURN TO:

Haibo Chen

Fax: 73 59 55 28 or E-mail: haibo@marin.ntnu.no

*Department of Marine Technology
Norwegian University of Science and Technology
N-7491 Trondheim*

Answer format: Fill in choices, numbers or comments in each Answer: field.

GENERAL INFORMATION OF DRIVE-OFF

Definition:

The tanker drive-off is defined in the following context as: Tanker (in DP) moves ahead or astern from its target/wanted position in tandem loading. This is not a planned or wanted movement.

Further note: Tanker drive-off does not mean that the collision or other serious incidents in tandem loading will happen. Successful intervention from Captain/DP officer can save the situation.

1. **Approximately how many times of tandem loading operations (with FPSO/FSU in the North Sea) have you been involved in?**

Answer:

2. **Based on your past operational experience, have you ever experienced any tanker drive-off situation (both ahead and astern) in the tandem loading operation?**

A: No B: Yes ↓ How many? _____

Answer:

3. **If you have experienced tanker drive-off situation(s) in tandem loading, what was your position when the drive-off(s) happened (please fill in the corresponding number of drive-off(s) with the position you were at that time)?**

A: Captain: ____ B: Chief Officer: ____ C: 1st Officer: ____ D: 2nd Officer: _____

4. **Approximately how many times of offshore loading operation with non-tandem concepts, e.g. SPM, OLS, SAL, STL in the North Sea, have you been involved in?**

Answer:

5. **Based on your past operational experience, have you ever experienced any tanker drive-off situation in these non-tandem loading operation?**

A: No B: Yes ↓ How many? _____

Answer:

TANKER DRIVE-OFF RECOVERY**Assumption:**

During the loading phase in DP Weathervane Mode, due to some unknown failure, your vessel is starting to have a 40% forward thrust drive-off.

1. What will be the first signal that makes you notice “something is going wrong”?

- A: DP speed alarm (operator select)
- B: DP max. speed alarm (system select)
- C: BLOM PMS max. speed alarm (system select)
- D: DP Distance Short warning
- E: DP Distance Critically Short alarm
- F: Thruster output on DP console before any alarm
- G: DARPS screen which shows the speed and the position, before any alarm
- H: Engine sound and vibration
- I: Other signal – please specify: _____

Answer:**2. After detecting “something is going wrong”, what are the essential data (multiple choices) that you need in order to clarify the situation, i.e. to find out whether or not this is a drive-off?**

- A: Tanker speed information
- B: Tanker position and heading relative to FPSO
- C: Main propeller(s) pitch information
- D: Main engine(s) output information
- E: Wind speed and direction
- F: Wave information
- G: Other information – please specify: _____

Answer:

1. Below you find a list (A-I) of information sources, in order to clarify the situation, i.e. to find out whether or not this is a drive-off, what is the sequence of your check? (For example: A-B-C-E means A first, followed by B, and then C, and E is the last.)

A: DP console
 B: BLOM PMS screen
 C: DARPS screen
 D: Artemis screen
 E: Main propeller(s) pitch indicator
 F: Main engine(s) RPM indicator
 G: Wind sensor
 H: Wave measurement
 I: Other equipment – please specify: _____

Probable sequence checks:

2. To finish the data check in Question 8 and confirm that this is a real drive-off, how long time do you think is reasonable, starting from the first signal you get which indicates “something is going wrong”?

A: within 20 seconds
 B: within 40 seconds
 C: within 60 seconds
 D: other time – please specify: _____

Answer:

3. Assume that you have identified that you are in the drive-off situation, manual intervention is supposed to be performed. Which way do you prefer to take action? And why?

A: Select Manual DP and use DP joystick (with high gain)
 B: Switch off DP and use steering gear manually

Answer:

Reason:

1. If you are working on a DP2 tanker: Which recovery actions do you prefer? and Why?

A: Try to rotate the vessel by using max. thruster and max. rudder capacities, and steer the vessel away from FPSO stern, no effort is made to initiate the astern pitch.

B: Try to stop the vessel by initiating astern pitch, no effort is made to initiate vessel rotation.

C: Try to stop the vessel by initiating astern pitch, combined with the effort to rotate vessel by using max. thruster and rudder capacities.

Answer:

Reason:

2. If you are working on a DP1 tanker: Which recovery actions do you prefer? and Why?

A: Try to rotate the vessel by using max. thruster and max. rudder capacities, and steer the vessel away from FPSO stern, no effort is made to initiate the astern pitch.

B: Try to stop the vessel by initiating astern pitch, no effort is made to initiate vessel rotation.

C: Try to stop the vessel by initiating astern pitch, combined with the effort to rotate vessel by using max. thruster and rudder capacities.

Answer:

Reason:

3. How long time do you think is reasonable to decide what to do, in which way, and then initiate the recovery action, starting from the confirmation of drive-off situation?

A: immediately after drive-off confirmation

B: within 10 seconds

C: within 20 seconds

D: within 30 seconds

Answer:

POTENTIAL RISK-REDUCING MEASURES

Purpose:

Several potential measures to improve tandem loading safety are listed below. Please comment upon them.

1. **To help early detection of drive-off situation, the present alarm settings (including speed alarms, distance alarm/warning, engine output alarm) in your opinion are:**

A: Practically effective

B: Not practically effective

C: Other viewpoints – please specify, e.g. what should be done for alarms?

Answer:

Other viewpoints:

2. **What is your opinion regarding increasing the separation distance between FPSO and shuttle tanker in tandem loading, in order to give more time for “decision making” and “action formulation” to avoid collision in tanker drive-off scenario?**

A: This measure is practically effective, and should be implemented.

B: This measure may lead to higher tanker impact speed on FPSO and higher collision consequence if collision happens, and therefore should not be implemented.

C: Other viewpoints – please specify:

Answer:

Other viewpoints? / What is your preferred separation distance?

3. **What else do you think should be done to improve the tandem loading safety?**

Comment:

PREVIOUS DR.ING. THESES

From the previous Department of Marine Structures

- Kavlie, Dag : Optimization of Plane Elastic Grillages. 1967.
- Hansen, Hans R. : Man-Machine Communication and Data-Storage Methods in Ship Structural Design. 1971.
- Gisvold, Kaare M. : A Method for non-linear mixed -integer programming and its Application to Design Problems.
- Lund, Sverre : Tanker Frame Optimization by means of SUMT-Transformation and Behaviour Models. 1971.
- Vinje, Tor : On Vibration of Spherical Shells Interacting with Fluid. 1972.
- Lorentz, Jan D. : Tank Arrangement for Crude Oil Carriers in Accordance with the new Anti-Pollution Regulations. 1975.
- Carlsen, Carl A. : Computer-Aided Design of Tanker Structures. 1975.
- Larsen, Carl M. : Static and Dynamic Analysis of Offshore Pipelines during Installation. 1976.
- Hatlestad, Brigit : The Finite Element Method used in a Fatigue Evaluation of Fixed Offshore Platforms. 1979.
- Valsgård, Sverre : Finite Difference and Finite Element Method Applied to Non-Linear Analysis of Plated Structures. 1979.
- Pettersen, Erik : Analysis and Design of Cellular Structures. 1979.
- Nordsve, Nils T. : Finite Element Collapse Analysis of structural Members considering Imperfections and Stresses due to Fabrication. 1980.
- Fylling, Ivar J. : Analysis of towline Forces in Ocean towing Systems. 1980.
- Haver, Sverre : Analysis of Uncertainties related to the stochastic Modelling of Ocean Waves. 1980.
- Odland, Jonas : On the Strength of welded Ring stiffened cylindrical Shells primarily subjected to axial Compression. 1981.
- Engesvik, Knut : Analysis of Uncertainties in the fatigue Capacity of Welded Joints. 1982.
- Eide, Oddvar Inge : On Cumulative Fatigue Damage in Steel Welded Joints. 1983.
- Mo, Olav : Stochastic Time Domain Analysis of Slender Offshore Structures. 1983.
- Amdahl, Jørgen : Energy absorption in Ship-platform impacts 1983.
- Czujko, Jerzy : Collapse Analysis of Plates subjected to Biaxial Compression and

- Lateral Load. 1983.
- Soares, C. Guedes : Probabilistic models for load effects in ship structures. 1984.
- Mørch, Morten : Motions and mooring forces of semi submersibles as determined by full-scale measurements and theoretical analysis. 1984.
- Engseth, Alf G. : Finite Element Collapse Analysis of Tubular Steel Offshore Structures. 1985.
- Baadshaug, Ola : Systems Reliability Analysis of Jacket Platforms. 1985. (Confidential)
- Hessen, Gunnar : Fracture Mechanics Analysis of Stiffened Tubular Members. 1986.
- Taby, Jon : Ultimate and post-ultimate strength of dented tubular members. 1986.
- Wessel, Heinz-J. : Fracture mechanics analysis of crack growth in plate girders. 1986.
- Leira, Bernt Johan : Gaussian Vector-processes for Reliability Analysis involving Wave-induced Load Effects. 1987.
- Xu Jun : Non-linear Dynamic Analysis of Space-framed Offshore Structures. 1988.
- Guoyang Jiao : Reliability Analysis of Crack Growth under Random Loading considering Model Updating. 1989.
- Olufsen, Arnt : Uncertainty and Reliability Analysis of Fixed Offshore Structures. 1989.
- Wu Yu-Lin : System Reliability Analyses of Offshore Structures using improved Truss and Beam Models. 1989.
- Farnes, Knut-Arild : Long-term Statistics of Response in Non-linear Marine Structures. 1990.
- Sotberg, Torbjørn : Application of Reliability Methods for Safety Assessment of Submarine Pipelines. 1990.
- Hoen, Christopher : System Identification of Structures Excited by Stochastic Load Processes. 1991.
- Sødahl, Nils : Methods for Design and Analysis of Flexible Risers. 1991.
- Haugen, Stein : Probabilistic Evaluation of Frequency of Collision between Ships and Offshore Platforms. 1991.
- Ormberg, Harald : Non-linear Response Analysis of Floating Fish Farm Systems. 1991.
- Marley, Mark J. : Time Variant Reliability Under Fatigue Degradation. 1991.
- Bessason, Bjarni : Assessment of Earthquake Loading and Response of Seismically

- Isolated Bridges. 1992.
- Søvik, Svein : On Stresses and Fatigue in Flexible Pipes. 1992.
- Dalane, Jan Inge : System Reliability in Design and Maintenance of Fixed Offshore Structures. 1993.
- Karunakaran, Daniel : Nonlinear Dynamic Response and Reliability Analysis of Drag-dominated Offshore Platforms. 1993.
- Passano, Elizabeth : Efficient Analysis of Nonlinear Slender Marine Structures. 1994.
- Bech, Sidsel M. : Experimental and Numerical Determination of Stiffness and Strength of GRP/PVC Sandwich Structures. 1994.
- Hovde, Geir Olav : Fatigue and Overload Reliability of Offshore Structural Systems, Considering the Effect of Inspection and Repair. 1995.
- Wang, Xiaozhi : Reliability Analysis of Production Ships with Emphasis on Load Combination and Ultimate Strength. 1995.
- Hellan, Øyvind : Nonlinear Pushover and Cyclic Analyses in Ultimate Limit State Design and Reassessment of Tubular Steel Offshore Structures. 1995.
- Hermundstad, Ole A. : Theoretical and Experimental Hydroelastic Analysis of High Speed Vessels. 1995.
- Eknes, Monika Løland : Escalation Scenarios Initiated by Gas Explosions on Offshore Installations. 1996.
- Halse, Karl Henning : On Vortex Shedding and Prediction of Vortex-Induced Vibrations of Circular Cylinders. 1997.
- Igland, Ragnar Torvanger : Reliability Analysis of Pipelines during Laying, Considering Ultimate Strength under Combined Loads. 1997.
- Vikestad, Kyrre : Multi-Frequency Response of a Cylinder Subjected to Vortex Shedding and Support Motions. 1998
- Azadi, Mohammad R. E. : Analysis of Static and Dynamic Pile-Soil-Jacket Behaviour. 1998.
- Videiro, Paulo Mauricio : Reliability Based Design of Marine Structures. 1998.
- Mainçon, Philippe : Fatigue Reliability of Long Welds Application to Titanium Risers. 1999.
- Langhelle, Nina Kristin : Experimental Validation and Calibration of Nonlinear Finite Element Models for Use in Design of Aluminium Structures Exposed to Fire. 1999.
- Berstad, Are Johan : Calculation of fatigue damage in ship structures. 1999.
- Tveiten, Bård Wathne : Fatigue Assessment of Welded Aluminum Ship Details. 1999.
- Sagli, Gro : Model Uncertainty and Simplified Estimates of Long Term Extremes

- of Hull Girder Loads in Ships. 2000.
- Tronstad, Harald : Nonlinear Analysis and Design of Cable Net Structures Like Fishing Gear Based on the Finite Element Method. 2000.
- Wang, Lihua : Probabilistic Analysis of Nonlinear Wave-induced Loads on Ships. 2001.
- Kristensen, Odd H.H. : Ultimate Capacity of Aluminium Plates under Multiple Loads, Considering HAZ Properties. 2001.
- Heggelund, Svein E. : Calculation of Global Design Loads and Load Effects in Large High Speed Catamarans. 2001.
- Babalola, Olusegun T. : Fatigue Strength of Titanium Risers - Defect Sensitivity. 2001.
- Mohammed, Abuu Khalifa: Nonlinear Shell Finite Elements for Ultimate Strength and Collapse Analysis of Ship Structures. 2001.
- Økland, Ole : Numerical and experimental investigation of whipping in twin hull vessels exposed to severe wet deck slamming. 2002.
- Ge, Chunhua : Global Hydroelastic Response of Catamarans due to Wetdeck Slamming. 2002.
- Byklum, Eirik : Nonlinear Shell Finite Elements for Ultimate Strength and Collapse Analysis of Ship Structures. 2002