

*Nordic Steel Construction Conference 2012
Hotel Bristol, Oslo, Norway
5-7 September 2012*

CLASSIFICATION BOUNDARIES FOR STIFFNESS OF BEAM-TO-COLUMN JOINTS AND COLUMN BASES

Ina Birkeland^{a,*}, Arne Aalberg^a and Svein Kvam^b

^a *Department of Structural Engineering, NTNU, Rich. Birkelandsvei 1a, NO-7491 Trondheim, Norway*

^b *Rambøll Kristiansand, Henrik Wergelandsgate 29, NO-4662 Kristiansand, Norway*

* Author for contact. Tel.: +47 908 60 505; E-mail: ina.birkeland@ramboll.no

Abstract: Eurocode 3 part 1-8 gives stiffness boundaries for nominally pinned, semi-rigid and rigid beam-to-column joints and for semi-rigid and rigid column bases. The background for these limits has been investigated and analysed to see how they affect the resulting moment- and deflection distributions for a range of portal frames. The analyses show that for some types of frames the results are affected as much as 50 % in non – conservative direction. FE simulations performed for a commonly used column base which traditionally is assumed to be nominally pinned shows that the actual rotational stiffness is so high that the base should be classified as semi-rigid.

1 Introduction

The classification of the stiffness for beam-to-column and column-base joints provides valuable information for the designer as to how the structure and its joints can be modelled in a frame analysis. In general, structural joints are classified according to their stiffness, strength or rotation capacity properties. The choice of joint model in an analysis, for instance by assuming pinned or rigid conditions, may have a significant effect on the internal distribution of forces and moments in the frame. This again may significantly affect the elastic critical force and the load carrying capacity and the displacement distribution of the frame. The objective of this paper is to show in which way the joint rotational rigidity affects the behaviour of a typical building frame. A review of the background of the stiffness limits is given. The elastic response of three typical portal frames, with three load combinations including distributed loads on the members, have been determined. The results are compared with the stiffness limits given in Eurocode 3 part 1-8 [1], to see if use of the boundaries gives satisfactory results.

2 Classifications boundaries for stiffness

For beam-to-column joints and column bases the classification stiffness boundaries are given in section 5.2.2.5 of Eurocode 3-1-8 [1]. A joint can be rigid, nominally pinned or semi-rigid. The stiffness limits for rigid beam-to-column joints were derived by Biljaard & Steenhuis [2], considering the typical portal frame as shown in Fig.1. The frame has pinned supports at the column bases, and an elastic rotational spring models the flexibility of the joints connecting the column and the beam. The loading consists of vertical forces applied to the top of the columns.

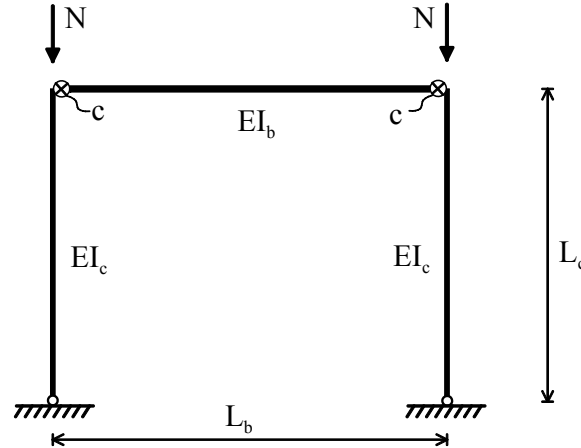

Fig. 1: Portal frame with flexural spring between columns and beam.

The rotational stiffness of the spring is c , and the flexural stiffness of beam and column are EI_b/L_b and EI_c/L_c , respectively. The relative joint stiffness is defined by

$$\hat{c} = c \frac{L_b}{EI_b} \quad (1)$$

The parameter ρ expresses the ration between the flexural stiffness of the beam and column

$$\rho = \frac{EI_b}{EI_c} \frac{L_c}{L_b} \quad (2)$$

Biljaard and Steenhuis stated that a joint can be considered as rigid if the drop in frame capacity is less than 5 % compared to the case with infinitely rigid joints. Here, the frame capacity (failure load) N_u was approximated by the Merchant – Rankine formula:

$$\frac{1}{N_u} = \frac{1}{N_{pl}} + \frac{1}{N_{cr}} \quad (3)$$

where N_{pl} is the plastic capacity and N_{cr} is the critical load of the frame.

For the present frame and loads, N_{cr} is the only factor that depends on the joint stiffness, while the applied centric force N_{pl} is independent of the joint stiffness. The stiffness limit for a rigid joint was hence derived on the basis of this value. When

$$N_{cr}(c) \geq 0.95 N_{cr}(c = \infty) \quad (4)$$

it follows automatically from Eq. (3) that

$$N_u(c) \geq 0.95 N_u(c = \infty) \quad (5)$$

and the criterion is fulfilled.

The two relevant elastic buckling modes are shown in Fig. 2; a symmetric buckling mode (non-sway) for the braced frame and anti-symmetric mode (sway) for the unbraced one.

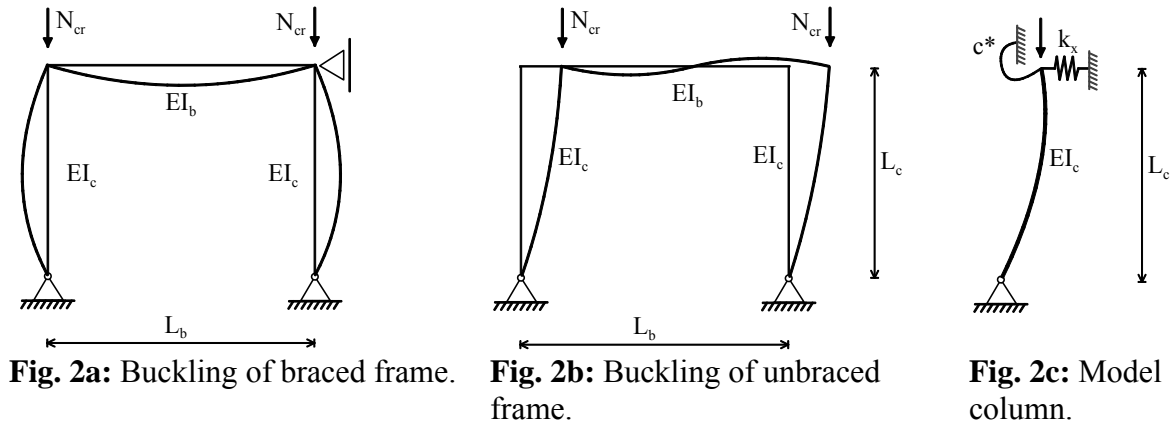

The critical loads N_{cr} are derived from a standard column model (Fig. 2c). The translational stiffness is $k_x = \infty$ for the braced frame and $k_x = 0$ for unbraced one. The stiffness c^* depends on the joint stiffness and the rotational stiffness of the beam

$$\frac{1}{c^*} = \frac{1}{c} + \frac{1}{k_{beam}} \tag{6}$$

In the present case $k_{beam} = 2EI_b/L_b$ and $k_{beam} = 6EI_b/L_b$, respectively for the braced and unbraced frame. The governing transcendent equation for the model column is solved for the stiffness value c which corresponds to a 5 % drop in N_{cr} . Details of the derivation are given in [3] and [7].

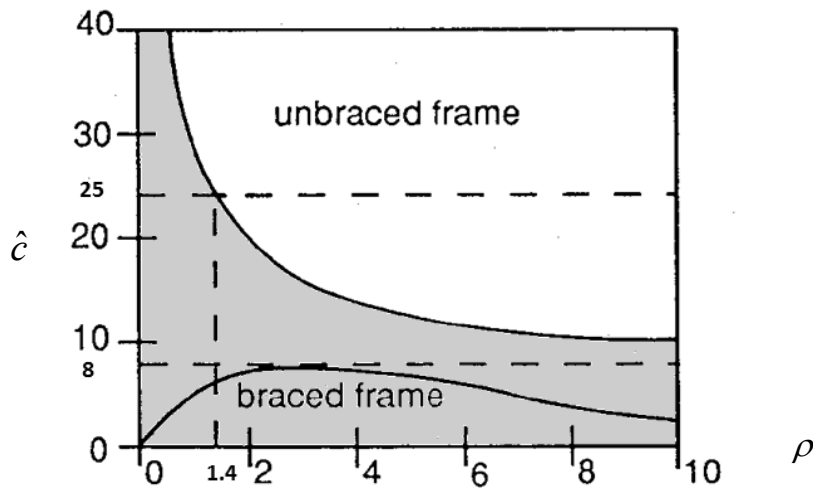

Figure 3: Stiffness boundaries for braced and unbraced frame, from [2].

Figure 3 shows the relative joint stiffness \hat{c} as a function of the frame parameter ρ for both the braced and the unbraced frame [2]. The two horizontal dashed lines at $\hat{c}=8$ and $\hat{c}=25$ represent the defined stiffness limits adopted in Eurocode 3-1-8. For the braced frame all frame geometries lie on the safe side of the limit. It should, however, be noted that the present analyses (Figs. 4 and 5) gave a maximum value $\hat{c}=6,4$ for $\rho=2$. The curve in Fig. 3 has a maximum $\hat{c}=8$ for approximately the same value of ρ . Value $\hat{c}=8$ may have been chosen to provide some extra safety, in order to account for a reduced value of N_{cr} that may arise from a

possible flexibility of the bracing system. Eurocode 3-1-8 states that the limit $\hat{c}=8$ may be used “for frames where the bracing system reduces the horizontal displacement by at least 80 %”, i.e. compared with the unbraced one.

For the unbraced frame the defined stiffness boundary $\hat{c}=25$ intersects the graph at $\rho=1,4$, where the curve has a steep gradient. The reasons for choosing $\hat{c}=25$ are discussed in [2]. The main argument is that frames having smaller ρ -values are not very realistic, as such frames are very slender. Thus, the chosen boundary does not cause a significant reduction in the capacity of the frame according to Eq. (3), even when used for frame factors significantly below $\rho=1,4$. In [1] the use of $\hat{c}=25$ is valid for frames down to $\rho=0,1$, for lower values the joint should be considered semi-rigid.

Birkeland et al. [3] have shown that the reduction in N_{cr} varies from 5 % at $\rho=1,4$, to 16,5 % at $\rho=0,1$, following a nonlinear curve. Furthermore, using Eq. (3), it may be shown that the decrease in frame capacity N_u remains less than 5 % for frames where $N_{cr} \geq 3N_{pl}$. In a design study on steel frames by Anderson and Lok [4], typical ratios between N_{cr} and N_{pl} were found to be in the range 3 to 17, which supports the validity of the defined boundary above.

The boundary between nominally pinned and semi-rigid joint is set to $0,5 EI_b/L_b$ in Eurocode 3 part 1-8. In private communication F. Bijlaard stated that the background for this value was that a joint can be classified as nominally pinned if the moment transmitted is less than 20 % of the moment capacity of the weakest connected part in the joint. Thus

$$c \leq \frac{0,2M_{Rd,s}}{\phi_{end,s}} \quad (7)$$

Here some assumptions must be made for the load acting on the beam in order to be able to establish a boundary value. Introducing the moment capacity $M_{Rd,s}$ and the end-rotation $\phi_{end,s}$ for a simply supported beam, the following stiffness values are obtained [3]:

$$c \leq \frac{0,6EI_b}{L_b} \quad \text{for uniformly distributed load} \quad (8)$$

and

$$c \leq \frac{0,8EI_b}{L_b} \quad \text{for mid-span point load} \quad (9)$$

For frames in general the actual load situation and geometry may differ significantly, and the definition above is a bit “ad hock”. The defined stiffness limit $0,5EI_b/L_b$ seems hence quite reasonable.

3 Classification limit if fixed base of column is assumed

It is not obvious that the assumption of pinned supports at the column bases ensures a conservative solution for frame joint stiffness boundaries. Therefore, the column model in Fig. 2c, with rotationally fixed column base, was analysed [3]. The graphs shown in Figs. 4. and 5 depict the relationships obtained between stiffness \hat{c} and frame factor ρ . As seen, the results for the case with fixed column bases are on the safe side, i.e. they do not require any tighter boundaries than the case with pinned column bases.

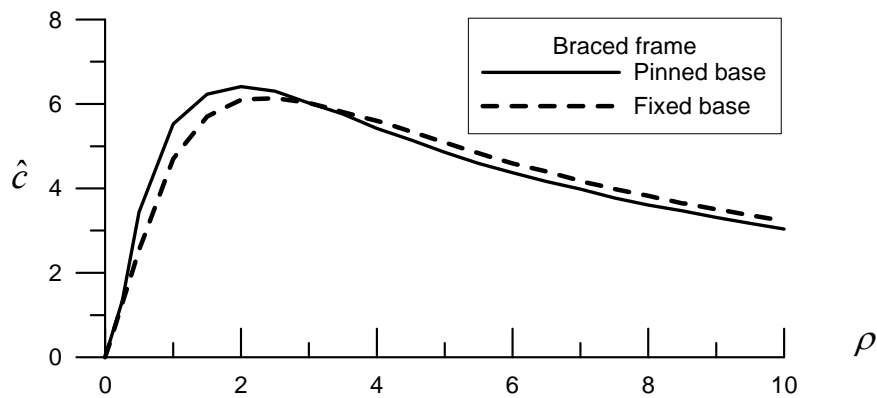

Fig. 4: Braced frame with pinned versus fixed column bases.

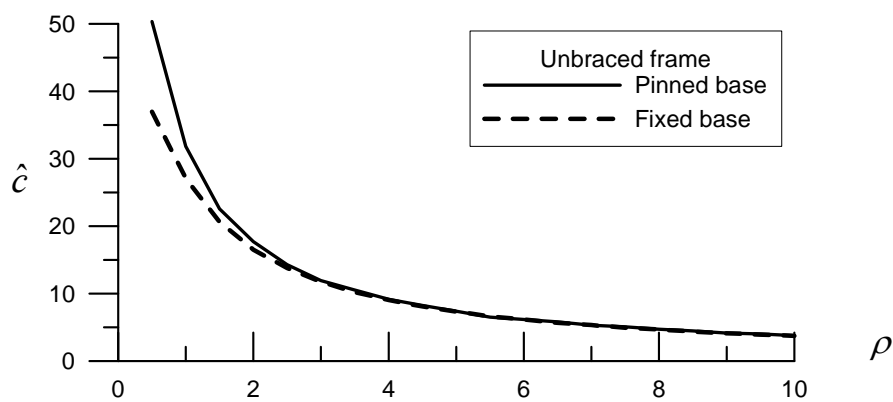

Fig. 5: Unbraced frame with pinned versus fixed column bases.

4 Effect on elastic response parameters

In Norway it is common practice to use elastic design when analysing building frames and similar structures. The stiffness limits discussed above is based on capacity, and does not take into account elastic design parameters as moment distribution and horizontal- and vertical displacements of the frame. Therefore, to see if the classification limits give reasonable results also for elastic design parameters, some test cases were established. Three different frames were chosen, and analysed using the commercial frame program “Focus Konstruksjon”, with linear elastic analysis using standard beam elements. The frames were analysed both with and without sideways support at the horizontal beam (i.e. braced and unbraced configuration), with either infinitely rigid beam-to-column joints or joints with rotational stiffness corresponding to the “rigid limit” in Eurocode, i.e. $\hat{c}=8$ for the braced frame and $\hat{c}=25$ for the unbraced frame.

4.1 Analysed frames

In this study frame geometry, member sizes and loading were chosen to cover what was expected to be cases of most interest, and to give a realistic distribution and magnitude of moments and frame displacements. For the cases studied the three load distributions were; Loadcase1 - distributed vertical load (q) acting on the beam, Loadcase2 - distributed horizontal

loads (h_1+h_2) on the columns, and Loadcase3 - load on both the beam and the two columns ($q+h_1+h_2$). The frame factors studied were $\rho=0.1$, $\rho=0.7$ and $\rho=2.05$. The geometry and loading for Frame 1 are shown in Fig. 6, all three cases given in Table 1.

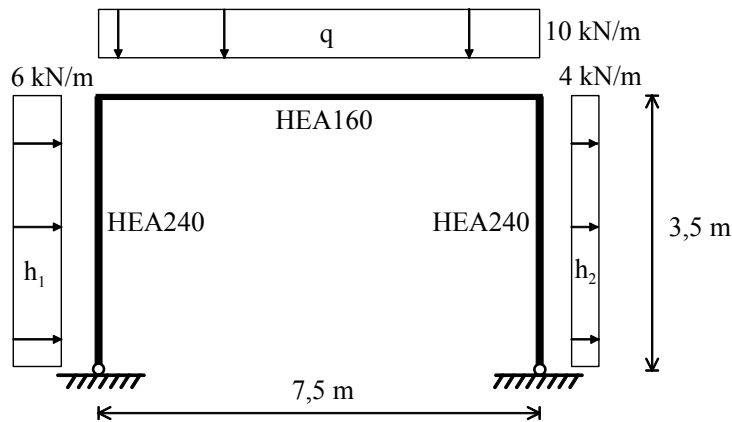

Fig. 6: Analysed frame “Frame 1”.

Table 1: Data for analysed frames

	L_b (m)	L_c (m)	Beam	Column	ρ	q (kN/m)	h_1 (kN/m)	h_2 (kN/m)
Frame 1	7,5	3,5	HEA160	HEA240	0,1	10	6	4
Frame 2	5,0	3,5	HEA200	HEA200	0,7	35	8	5
Frame 3	5,0	7,0	HEA220	HEA200	2,05	25	1,2	0,9

4.2 Analysis results

Table 2: Results Frame 1

FRAME 1 $\rho=0,1$ $8 EI_b/L_b=3741 \text{ kNm/rad}$ $25EI_b/L_b=11690 \text{ kNm/rad}$	Braced configura- tion			Unbraced configura- tion		
	$\hat{c}=\infty$	$\hat{c}=8$	change	$\hat{c}=\infty$	$\hat{c}=25$	change
<i>Loadcase 1</i>						
Vertical displacement (mm)	31.1	48.1	55 %	31.1	37.4	20 %
Beam span moment (kNm)	27.7	36.2	31 %	27.7	30.8	11 %
Corner moment (kNm)	44.4	36.3	-15 %	44.7	41.6	-7 %
<i>Loadcase 2</i>						
Horizontal displacement (mm)	-	-	-	48.9	58	19 %
Corner moment (kNm)	2.6	1.9	-27 %	32	31.9	-0.3 %
Column span moment (kNm)	7.9	8.3	5 %			
<i>Loadcase 3</i>						
Vertical displacement (mm)	30.9	47.9	55 %	32.7	38.7	18 %
Horizontal displacement (mm)	-	-	-	48.1	57.3	19 %
Beam span moment (kNm)	27.6	36	30 %	30.9	34	10 %
Corner moment (kNm)	46	37	-19 %	75.4	72.3	-4 %

The results from the analyses are given in Tables 2 to 4, in terms of the beam vertical displacement at the point with largest displacement and the horizontal displacement of the top of frame. Furthermore, the beam moment at mid-span, the largest beam-to-column joint moment (“corner moment”) and the largest column moment are given.

Table 3: Results Frame 2

FRAME 2 $\rho=0,7$ $8 EI_b/L_b=12398 \text{ kNm/rad}$ $25EI_b/L_b=38745 \text{ kNm/rad}$	Braced configura- tion			Unbraced configura- tion		
	$\hat{c}=\infty$	$\hat{c}=8$	change	$\hat{c}=\infty$	$\hat{c}=25$	change
<i>Loadcase 1</i>						
Vertical displacement (mm)	17.9	20.8	16 %	17.9	19	6 %
Beam span moment (kNm)	61.1	68.3	12 %	61.1	63.7	3 %
Corner moment (kNm)	49.5	42.5	-14 %	49.6	47	-5 %
<i>Loadcase 2</i>						
Horizontal displacement (mm)	-	-	-	41.9	45.5	9 %
Corner moment (kNm)	6.9	5.4	-22 %	41.1	41	-0.2 %
Column span moment (kNm)	9	9.6	1 %			
<i>Loadcase 3</i>						
Vertical displacement (mm)	17.7	20.6	16 %	17.7	18.7	8 %
Horizontal displacement (mm)	-	-	-	42.1	45.4	6 %
Beam span moment (kNm)	60.4	67.7	12 %	60.4	67.7	5 %
Corner moment (kNm)	55.8	47.2	-15 %	90.1	87.5	-5 %

Table 4: Results Frame 3

FRAME 3 $\rho=2,05$ $8 EI_b/L_b=18178 \text{ kNm/rad}$ $25EI_b/L_b=56805 \text{ kNm/rad}$	Braced configura- tion			Unbraced configura- tion		
	$\hat{c}=\infty$	$\hat{c}=8$	change	$\hat{c}=\infty$	$\hat{c}=25$	change
<i>Loadcase 1</i>						
Vertical displacement (mm)	12.9	13.5	5 %	12.9	13.1	2 %
Beam span moment (kNm)	57.5	59.6	4 %	57.5	58.2	1 %
Corner moment (kNm)	22.2	20	-10 %	22.2	21.5	-3 %
<i>Loadcase 2</i>						
Horizontal displacement (mm)	-	-	-	81.7	84.8	4 %
Corner moment (kNm)	6	5.3	-12 %	26.7	26.7	0 %
Column span moment (kNm)	4.7	4.9	4 %			
<i>Loadcase 3</i>						
Vertical displacement (mm)	12.8	13.4	5 %	12.8	13	2 %
Horizontal displacement (mm)	-	-	-	83.3	86.1	3 %
Beam span moment (kNm)	57	59.1	4 %	59	59.7	1 %
Corner moment (kNm)	27.7	24.9	-10 %	48.4	47.7	-1 %

4.3 Discussion

As expected, the main effects of reducing the joint stiffness from fully rigid to either $\hat{c}=8$ (for braced) or $\hat{c}=25$ (for unbraced), is a reduction of the frame corner moment, while the sagging beam moment and the vertical displacements are increased. The percentage change is given in the tables. The most significant changes are obtained for Frame 1, which has the largest span ($\rho=0,1$). For the braced case with Loadcase 1 (vertical load only), the vertical displacement of the beam increased by 55 % and the span moment by 31 %. For Loadcase 2 (horizontal load only) the corner moment decreased by 27 %. In general, the changes in moment and displacements are far larger than the maximum 5 % change postulated when the stiffness limits were established. Furthermore, the lower ρ becomes, i.e. combining high column stiffness with slender beam, the greater the differences in moment and displacements become for the two cases of joint stiffness. For braced Frame 2, with $\rho=0,7$ and with Loadcase 1, the increase in beam displacement and beam moment are 16 % and 12 % respectively. For Frame 3 with $\rho=2,05$ the same values are 5 % and 4 %, i.e. within the “intention”.

Also for unbraced frames the percentage changes in displacement and moments decrease when ρ increases. The changes are, however, less than for the braced ones. For unbraced frames the horizontal displacement may quite well be the governing design parameter. Comparing frames with rigid joints with frames with rigid-limit joints (i.e. $25EI_b/L_b$) we see the same tendency as observed for the vertical displacement and span moment in the beam. For Frame 1 ($\rho=0,1$) the horizontal displacement increased by 19 %, for Frame 2 ($\rho=0,7$) by 9 % and for Frame 3 ($\rho=2,05$) by 4 %.

4.4 Assessment of the boundaries for use in elastic design

The reason for the significant increase in displacement and span moment (comparing rigid and rigid-limit cases) is obviously that these parameters were not used when deriving the classification limits. The background for the stiffness boundaries in [2] was given by Meijer [7], who studied the influence of the rotational stiffness on N_{cr} and N_u , as well as moment and displacement distribution. His study showed that for braced frames, deflection and span moment posed the most stringent requirement on the rotational stiffness, while the horizontal displacement was most important for the unbraced frames. The stiffness boundary for all the three parameters, deflection, span moment and horizontal displacement, increase exponentially when ρ goes toward zero. Thus, for small frame factors, approximately $\rho < 1$, the rotational stiffness of the joints needs to be very large to behave as infinitely rigid.

For higher values of ρ the limits for rigid joints approaches a constant value. The use of these constant values as boundaries for rigid joints may be feasible, but it will be reasonable to use different limits for different design criterions [3].

The stiffness boundaries are intended to help the designer to establish the global design model, and it should be kept in mind that the most accurate results are obtained when using the actual rotational stiffness of the joint. Many of today’s standard design programs have functions which include various spring elements for joints, and some programs have functions which allow the designer to determine the joint stiffness “automatically”. For the analysis program the correct modelling of the joint properties causes almost no extra computational time. Development of very detailed and extensive classification boundaries may hence not be very useful.

5 Classification of column base

For column base Eurocode 3 part 1-8 gives only a “rigid-limit”, which depends on the column stiffness and a reference-slenderness. The background for the provisions is discussed in details by Wald et al. in [6], who stated that all column bases will have a rotational stiffness greater than what should be classified as nominally pinned. Therefore no “pinned-limit” is defined. As for beam-column joints the boundary distinguishes between braced and unbraced frames. For braced frames, the stiffness limit of the column base will primarily be affected by the relative slenderness $\bar{\lambda}$ of the column, while for unbraced frames the limit is also affected by the horizontal displacements. In the development of the formulas, two simplified conditions were assumed, either rigid or pinned beam-to-column joint. For both cases the restriction of a maximum of 5 % reduction of N_{cr} was used. For unbraced frame, a restriction on horizontal displacement was applied, and a 10 % increase was deemed acceptable [6]. Assuming again the 5 % reduction in buckling load, and applying standard buckling solutions [8], the stiffness limits for braced frame become $48EI_c/L_c$ for column base for column with rotationally fixed column top, and $36EI_c/L_c$ for pinned top. The former requirement is reflected in the standard. For braced frames with short columns with $\bar{\lambda} \leq 0,5$, yielding is more important than buckling, and all column base designs may be assumed as rigid.

Ref [3] gives results for a wide range of frames with rigid and rigid-limit column bases, covering the range of slenderness relevant for the Eurocode 3-1-8 provisions for column base stiffness limit. The applied loading was uniformly distributed load as in Fig. 6, in contrast to the horizontal point load at the frame corner used in [6]. Two load-cases were investigated; one with vertical load on the beam (q), and the other with vertical load and horizontal load on the columns ($q+h_1+h_2$). The moment at the column base, in the column span and in the frame corner were monitored, together with the horizontal displacement of the column for braced frame, and the frame corner for the unbraced ones.

Compared with the case with infinitely rigid bases, it is observed that the use of the stiffness limit causes significant changes in moments and sideways displacement in all frames considered. For all frames the corner moment changed more than 5 %. Typically, the moments in the column span and the frame corner increased by 5 % to 15 %. For obvious reasons larger changes were observed at the column base, where the moment depends directly on the modelled joint stiffness. For braced frame, the column span displacement changed from 5 % to 13 %. The results may indicate that the limit which was developed from the capacity criterion should be used with care if elastic response is sought.

For unbraced frame the main observation is that the stiffness limit causes an increase in frame sideways displacement of approximately 13 %, whereas the criterion used in the development of the limits was a maximum 10 % change. The sole reason for this difference is that the load distributions were different, distributed load versus point load at the frame corner.

6 Numerical simulation of column base

The FE model for a HEA120 column base is shown in Fig. 7. The dimensions of the welded base-plate are 140 mm by 130 mm, with thickness 12 mm. The base plate is bolted to the concrete foundation by two anchor bolts located between the flanges of the column, 80 mm apart. Bolts are grade 8.8 diameter 16 mm, with length 190 mm, and are fixed at their end in the

concrete. The base-plate in S355 is relatively thin, and should provide high flexibility of the joint. All parts are modelled with solid elements, and nonlinear simulations were carried out. Loading was strong axis bending by applying a point load to the cantilevered column, 500 mm from the base. In practice it is commonly assumed that the chosen base design is as close as one can get to a nominally pinned.

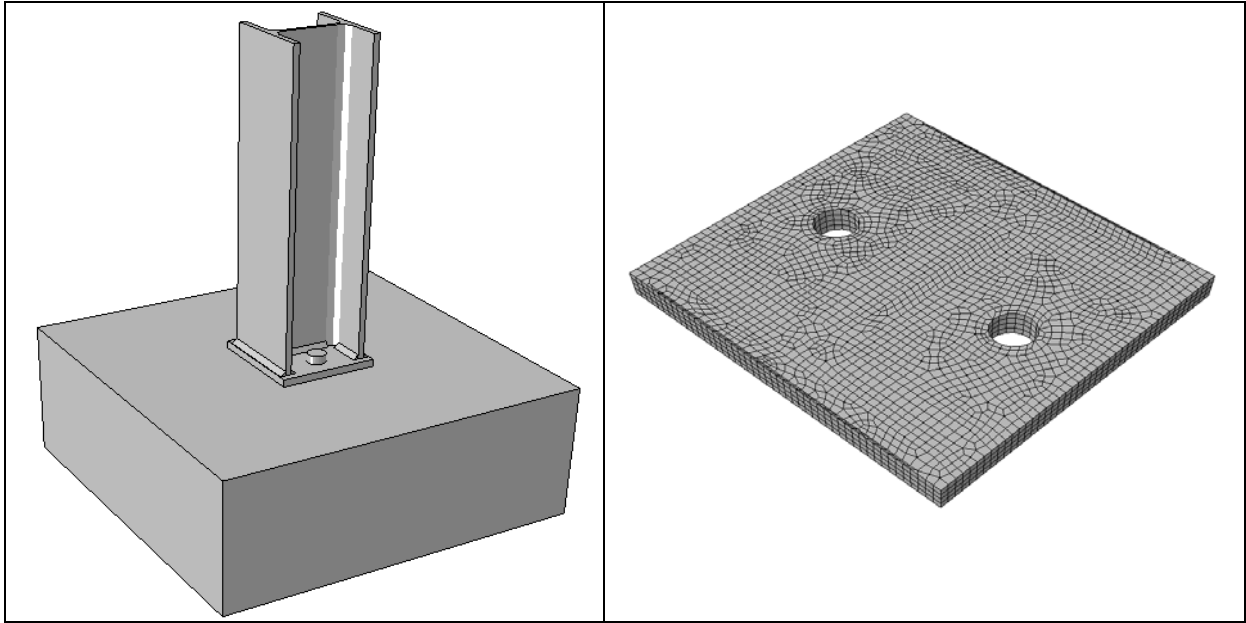

Fig. 7: Geometry of FE model of column base, and detailed view of end-plate.

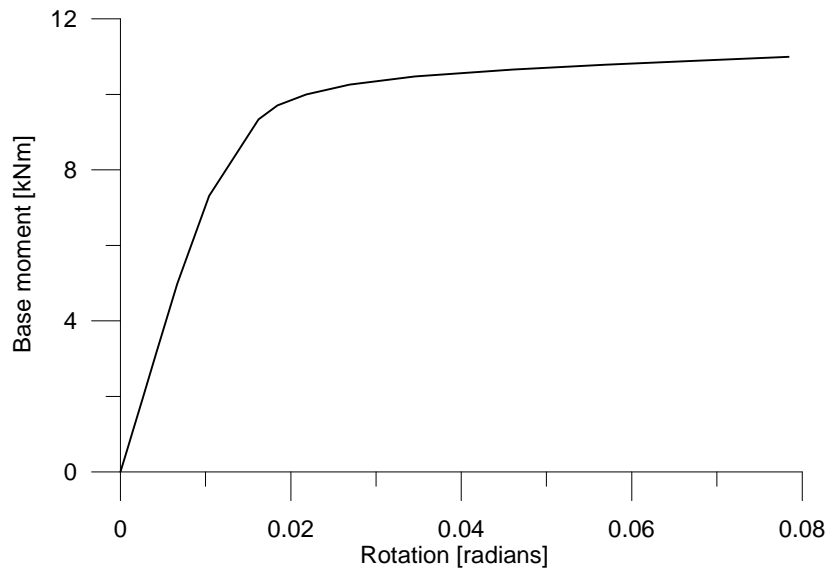

Fig. 8: Moment-rotation response of HEA120 column base.

The numerical analyses were performed using Abaqus. In order to simulate a condition of pure moment the base-plate is support in horizontal direction, i.e. the bolts develop only tension and no shear. Contact between bolts and concrete, bolts and plate, and plate and concrete, is modelled with surface-to-surface contact. The relation between column base moment and base rotation was determined from the applied horizontal force and the computed associated column displacement, corrected for the flexure of the column as a cantilever. The full re-

sponse curve is shown in Fig. 8. The computed initial rotational stiffness of the column base is $S_{j,ini}=750$ kNm/rad.

For a simple evaluation of the performance of the present column base we may use the overall dimension of Frame 2 in Table 1 as a case. The length of the beam and the columns are 5,0 m and 3,5 m, respectively. The reduced slenderness of a S355 HEA120 column in length 3,5 m, when pin-supported at both ends, is $\bar{\lambda} = 0.94$. For the column base to be classified as rigid, following equation 5.2b of Eurocode 3-1-8 for braced frame, a stiffness of $S_{j,ini}=2220$ kNm/rad is a necessary. This is three times the actual stiffness. If the frame was unbraced, the stiffness of the column base would have to be $S_{j,ini}=10900$ kNm/rad (equation 5.2d) in order to be classified as rigid, i.e. 15 times the actual stiffness.

As mention in the previous no pinned-limit is given for column base in Eurocode. A very simple suggestion could be to adopt a definition similar to that applied for beam-to-column connection, Eq. (7), i.e. assuming that the base can be considered pinned if not more than 20 % of the column moment capacity can be transmitted by the base joint. The relation then becomes

$$S_{j,ini} \leq \frac{0,5EI_c}{L_c} \quad (10)$$

Using the actual stiffness of the HEA120 column base (750 kNm/rad) in Eq. (10) we find for the column length a requirement of $L_c \leq 0,85$ m. Hence, the column must be unrealistic short to be classified as pinned. The conclusion is probably that Eq. (10) is unsuited as stiffness measure for the column base.

The influence of the column base joint stiffness was also investigated by elastic frame analyses, here comparing frames with pinned column base ($S_{j,ini}=0$) with frames with spring stiffness $S_{j,ini}=750$ kNm/rad at the base. The geometry of Frame 2 was again used, with Loadcase 3, i.e. vertical and horizontal distributed load. The results of the analyses are shown in Table 5, with comparison between moments and between displacements for braced and unbraced frame. As shown, changes in moments and displacement are less than 4 % for braced frame. This is quite as expected, as the moment stiffness at the column bases for braced frame normally is of small significance. However, for the unbraced frame the introduction of the spring stiffness 750 kNm/rad causes a large reduction in horizontal displacement (59 %), and a significant change in the moments.

Table 5: Frame 2 with HEA120, without and with rotational spring stiffness at bases

FRAME 2 With rigid beam-to-column joint. <i>Loadcase 3</i>	Braced configuration			Unbraced configuration		
	$S_{j,ini}=0$	$S_{j,ini}=750$ (kNm/rad)	change	$S_{j,ini}=0$	$S_{j,ini}=750$ (kNm/rad)	change
Vertical displacement (mm)	102.3	98.7	-3.5 %	104.1	99.1	-5 %
Horizontal displacement (mm)	-	-	-	252.4	103.1	-59 %
Beam midspan moment (kNm)	59.1	57.6	-2.5 %	62.2	57.6	-3 %
Corner moment (kNm)	56.1	56.7	1 %	90.1	70.7	-22 %

The comparisons clearly show that the present column base, despite its quite small rotational stiffness, ought to be modelled with its correct rotational stiffness in a frame analysis, at least when elastic response is the concern. In that way the present study supports the findings by [6].

7 Conclusions

The main conclusions are:

1. The classification limits for rigid beam-to-column joints in Eurocode 3-1-8 give un-conservative results considering elastic response parameters as frame moments and frame displacements.
2. Almost all column bases will act at least as semi-rigid and it is difficult to establish a limit for nominally pinned column base.

References

- [1] CEN, EN 1993-1-8: Eurocode 3: "Design of steel structures - Part 1-8: Design of joints". CEN (2005).
- [2] Bijlaard, F.S.K and Steenhuis, C.M. "Prediction of the influence of connection behaviour on the strength, deformations and stability of frames, by classification of connections". Bjorhovde, et al. *Connections in Steel Structures II*. Chicago : American Institute of Steel Construction, 1992.
- [3] Birkeland, I. Master thesis: Joints in buildings (in Norwegian). Department of Structural Engineering, NTNU 2011.
- [4] Anderson D. and Lok T.S."Design studies of unbraced, multi-storey frames". *The Structural Engineer*, Vol. 61B, No.2, June1983.
- [5] Bijlaard, F.S.K. Information given in mail. Spring 2011.
- [6] Wald, Frantisek, et al. "Steel column base classification". *HERON*, 53, 2008.
- [7] Meijer, H.S. "Influence of the rotational stiffness of column – beam connections on the behaviour of braced and unbraced frames (in Dutch). TU Delft, 1990.
- [8] Wood R.H. "Effective lengths of columns in multi-storey buildings". *The Structural Engineer*, 1974, Vol 52, 7.
- [9] Nethercot, D.A. "Frame structures: Global performance, static and stability behaviour. General report". *Journal of Constructional Steel Research*. 55, 2000.